

Xtreme Mix™

309518P

ENG

Plural Component Proportioner
For spraying two-component protective coatings.
Not approved for use in explosive atmospheres.



Important Safety Instructions

Read all warnings and instructions in this manual.
Save these instructions

See page 3 for model information, including maximum working pressure and approvals.

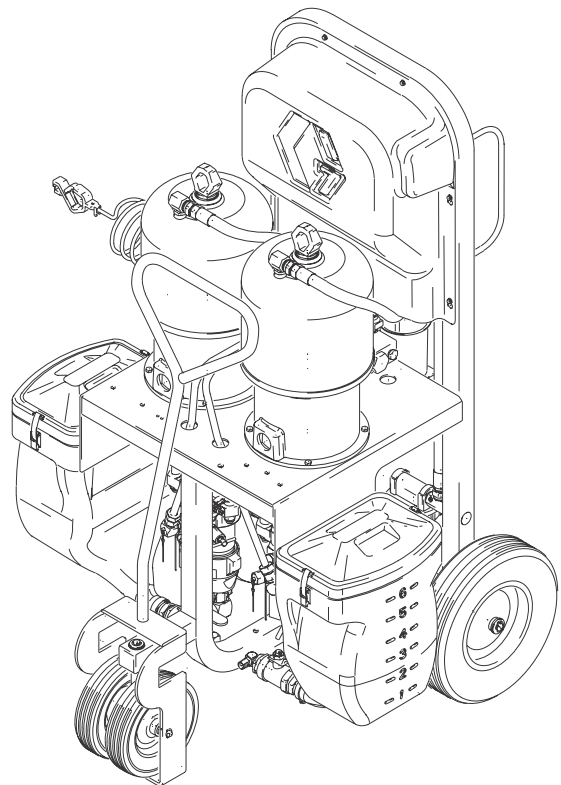

Contents

Xtreme Mix Models	3
Manual Conventions	4
Related Manuals	4
Warnings	5
Pressure Relief Procedure	7
Proper Lifting of Unit	8
Grounding	8
Shutdown	9
Maintenance	9
Metering Valve	9
Pump	9
Turbine Alternator	9
Air Filters	9
Pump Test	10
Troubleshooting	12
Alarms	15
Repair	16
Replacing Air Filter Element	16
User Interface	17
Pneumatic Control	20
Pump Air Manifold	22
Sampling Valve	23
Metering Valve/Manifold Assembly	24
Sensor	27
Electrical Schematic	28
Pneumatic Schematic	30
Pneumatic/Sensor Connections	31
Parts	32
Metering Valve Manifold 245824	41
Metering Valve Manifold 248843	41
Sampling Valve 245143	41
Repair Kit 249406	41
Technical Data	45
Graco Standard Warranty	48
Graco Information	48

Xtreme Mix Models

 **WARNING**

Do not install equipment approved only for non-hazardous location in a hazardous area. Substitution of components may impair intrinsic safety. See page 5.

Approved for Non-hazardous Location					
Xtreme Mix Part No.	Series	Pump Part No.	Pump Description	Maximum Working Pressure psi (MPa, bar)	Approvals
233863	A	249274	45:1 King	4500 (31, 310)	CE
233864	A	249275	56:1 King	5600 (38.6, 386)	
233865	A	249276	68:1 King	6800 (46.9, 469)	
233866	A	249277	80:1 King	7250 (50, 500)	
233867	A	249278	45:1 Quiet King	4500 (31, 310)	
233868	A	249279	56:1 Quiet King	5600 (38.6, 386)	
233869	A	249280	68:1 Quiet King	6800 (46.9, 469)	
233870	A	249281	80:1 Quiet King	7250 (50, 500)	
*248842	A	249276	68:1 King Remote Mix	5000 (34.5, 345)	

 *Model 248842 is designed for remote feed pumps and a remote mix manifold. It does not include hoppers, mix manifold, hose, or spray gun. Refer to manual 310794 for application layout.

Model 248842 is limited to 5000 psi (34.5 MPa, 345 bar) for use in “quick set” packages where heated hoses, whip hoses, and spray accessories are limited to 5000 psi (34.5 MPa, 345 bar). If all your downstream components are rated for 7000 psi (48 MPa, 483 bar), you can replace the standard relief valve with relief valve 113498.

Manual Conventions

WARNING

— Hazard Symbol

WARNING: a potentially hazardous situation which, if not avoided, could result in death or serious injury.

Warnings in the instructions usually include a symbol indicating the hazard. Read the general **Warnings** section for additional safety information.

CAUTION

CAUTION: a potentially hazardous situation which, if not avoided, may result in property damage or destruction of equipment.

Related Manuals

Component Manuals

Manual	Description
309535	Xtreme Mix Operation
311762	Xtreme Displacement Pump
309347 or 309348	King Air Motor King Quiet Air Motor
312145	XTR Spray Gun
309524	VISCON HP Heater
309525	Heated Hose Kit
308981	Husky 716 Diaphragm Pump
309615	Heater Bracket Kit
309568	Remote Manifold Kit
310797	Remote Mix Manifold
310794	Remote Mix Proportioning Systems
310863	Feed and Flush Kits
309827	Air Supply Kits

Note

Additional helpful information.

Components A and B

IMPORTANT!

Material suppliers can vary in how they refer to plural component materials.

Be aware that in this manual:

Component A refers to resin or major volume.





Component B refers to catalyst (curing agent) or minor volume.

This manual available in following languages:





Manual	Language	Manual	Language
309518	English	309609	Italian
309564	French	309610	Finnish
309565	Brazilian Portuguese	309611	Swedish
309566	Spanish	309612	Chinese
309567	German	309613	Korean
309608	Greek	309614	Japanese
310752	Dutch	310753	Norwegian
310777	Danish		

Warnings

The following general warnings are related to the safe setup, use, grounding, maintenance, and repair of this equipment. Additional more specific warnings may be found throughout the text of this manual where applicable.

 Warning	
	<p>FIRE AND EXPLOSION HAZARD</p> <p>Flammable fumes, such as solvent and paint fumes, in work area can ignite or explode. To help prevent fire and explosion:</p> <ul style="list-style-type: none"> • Use equipment only in well ventilated area. • Eliminate all ignition sources; such as pilot lights, cigarettes, portable electric lamps, and plastic drop cloths (potential static arc). • Keep work area free of debris, including solvent, rags and gasoline. • Do not plug or unplug power cords, or turn power or light switches on or off when flammable fumes are present. • Ground equipment and conductive objects in work area. See Grounding instructions. • Use only grounded hoses. • Hold gun firmly to side of grounded pail when triggering into pail. • If there is static sparking or you feel a shock, stop operation immediately. Do not use equipment until you identify and correct the problem. • Keep a fire extinguisher in the work area.
	<p>ELECTRIC SHOCK HAZARD</p> <p>Improper grounding, setup, or usage of the system can cause electric shock.</p> <ul style="list-style-type: none"> • Turn off and disconnect power at main switch before disconnecting any cables and before servicing equipment. • Connect only to grounded power source. • All electrical wiring must be done by a qualified electrician and comply with all local codes and regulations.
	<p>SKIN INJECTION HAZARD</p> <p>High-pressure fluid from gun, hose leaks, or ruptured components will pierce skin. This may look like just a cut, but it is a serious injury that can result in amputation. Get immediate surgical treatment.</p> <ul style="list-style-type: none"> • Do not point gun at anyone or at any part of the body. • Do not put your hand over the spray tip. • Do not stop or deflect leaks with your hand, body, glove, or rag. • Do not spray without tip guard and trigger guard installed. • Engage trigger lock when not spraying. • Follow Pressure Relief Procedure in this manual, when you stop spraying and before cleaning, checking, or servicing equipment.
	<p>MOVING PARTS HAZARD</p> <p>Moving parts can pinch or amputate fingers and other body parts.</p> <ul style="list-style-type: none"> • Keep clear of moving parts. • Do not operate equipment with protective guards or covers removed. • Pressurized equipment can start without warning. Before checking, moving, or servicing equipment, follow the Pressure Relief Procedure in this manual. Disconnect power or air supply.

 **Warning**

	<p>EQUIPMENT MISUSE HAZARD</p> <p>Misuse can cause death or serious injury.</p> <ul style="list-style-type: none"> • Do not exceed the maximum working pressure or temperature rating of the lowest rated system component. See Technical Data in all equipment manuals. • Use fluids and solvents that are compatible with equipment wetted parts. See Technical Data in all equipment manuals. Read fluid and solvent manufacturer's warnings. • Check equipment daily. Repair or replace worn or damaged parts immediately. • Do not alter or modify equipment. • For professional use only. • Use equipment only for its intended purpose. Call your Graco distributor for information. • Route hoses and cables away from traffic areas, sharp edges, moving parts, and hot surfaces. • Do not kink or overbend hoses or use hoses to pull equipment. • Comply with all applicable safety regulations.
	<p>BURN HAZARD</p> <p>Equipment surfaces and fluid that's heated can become very hot during operation. To avoid severe burns, do not touch hot fluid or equipment. Wait until equipment/fluid has cooled completely.</p>
	<p>TOXIC FLUID OR FUMES HAZARD</p> <p>Toxic fluids or fumes can cause serious injury or death if splashed in the eyes or on skin, inhaled, or swallowed.</p> <ul style="list-style-type: none"> • Read MSDS's to know the specific hazards of the fluids you are using. • Store hazardous fluid in approved containers, and dispose of it according to applicable guidelines.
	<p>PERSONAL PROTECTIVE EQUIPMENT</p> <p>You must wear appropriate protective equipment when operating, servicing, or when in the operating area of the equipment to help protect you from serious injury, including eye injury, inhalation of toxic fumes, burns, and hearing loss. This equipment includes but is not limited to:</p> <ul style="list-style-type: none"> • Protective eyewear • Clothing and respirator as recommended by the fluid and solvent manufacturer • Gloves • Hearing protection
	<p>RECOIL HAZARD</p> <p>Gun may recoil when triggered and cause you to fall and be seriously injured if you are not standing securely.</p>

Pressure Relief Procedure

WARNING



Follow **Pressure Relief Procedure** when you stop spraying and before cleaning, checking, servicing, or transporting equipment. Read warnings, page 5.

1. Engage trigger lock.

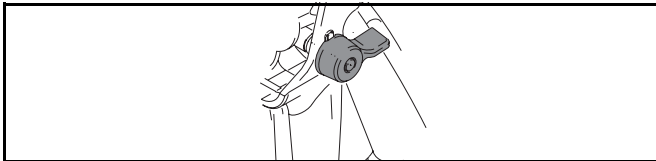

2. Press Stop .



3. Close main air shutoff valve on air supply line and on unit. Turn off air regulator.
4. Close fluid sampling and shutoff valves A and B.

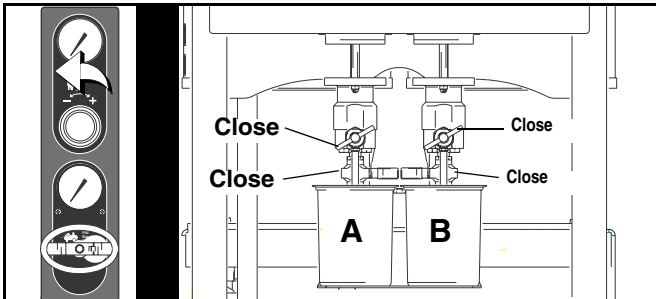

5. Disengage trigger lock.

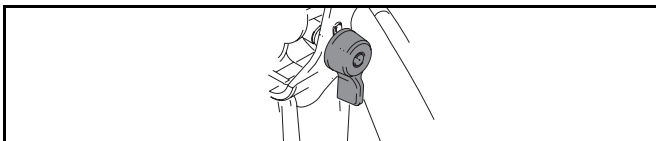

6. Hold a metal part of the gun firmly to a grounded metal pail. Trigger gun to relieve pressure.

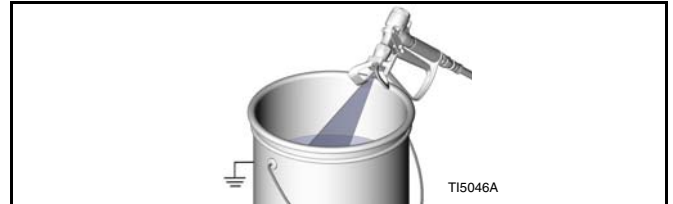

7. Engage trigger lock.

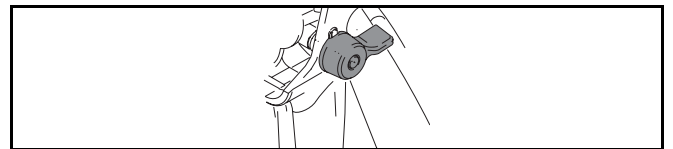

8. Place waste container under sampling valves, then open valves A and B slowly to relieve pressure between pump and metering valve.

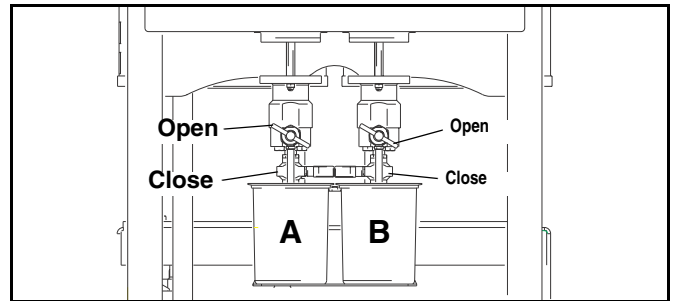

9. Close sampling valves A and B.

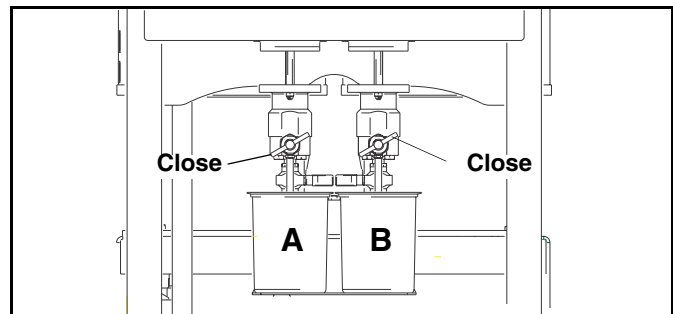

Proper Lifting of Unit

WARNING



Follow instructions below to avoid dropping or swinging unit or being struck by the cart handle, which can cause serious injury or damage to equipment.

Either remove the cart handle or secure it to the cart before lifting the unit. Connect a bridle swing, hooking an end to each of the Xtreme Mix air motor rings. Hook the center ring on a hoist. See FIG. 1. Carefully lift the Xtreme Mix unit; make sure it balances evenly.

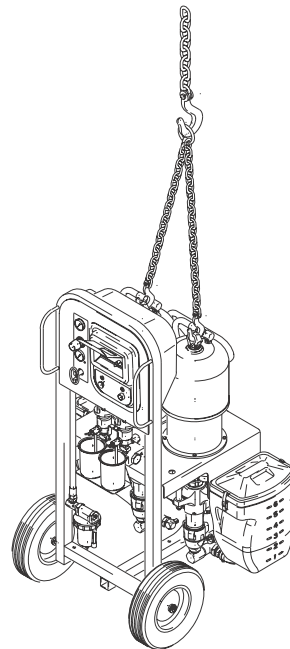

FIG. 1

Grounding

WARNING



Read warnings, page 5.

If the Xtreme Mix ground wire clamp (G) is disconnected during repair, be sure to reconnect it to a true earth ground before starting operation.

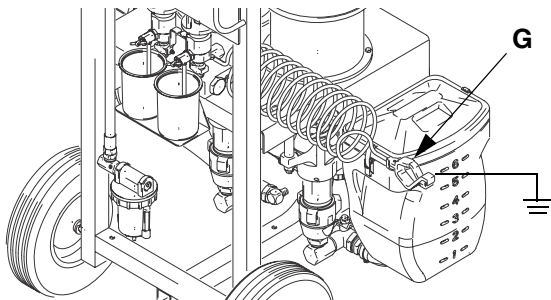

FIG. 2

Shutdown

Follow this procedure before prolonged shutdown or servicing equipment.



If your system includes heaters and heated hose, make sure they are turned off and cool before flushing.

1. Follow **Pressure Relief Procedure**, page 7. Engage trigger lock, turn off air regulator, and close main air shutoff valve. Remove spray tip.

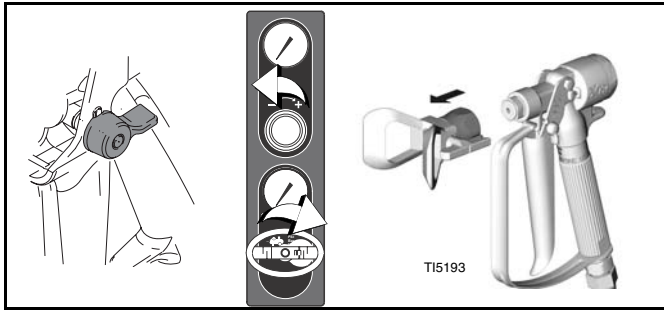

2. Follow **Full System Flushing** procedure in the Xtreme Mix Operation manual.
3. Follow **Pressure Relief Procedure**, page 7. Engage trigger lock.
4. *Before prolonged shutdown:* cap fluid outlets to keep solvent in the lines. Fill pump A and B packing nuts with throat seal liquid (TSL); follow instructions in pump manual.

Maintenance

Metering Valve

- Fill metering valves A and B packing nuts (627) with throat seal liquid (TSL) and tighten 1/4 turn after nut contacts packings; about 145-155 in/lbs (16-18 N•m). Check packing nut tightness after first hour of operation, again after 24 hours, then check as needed (when TSL discolors or seeps over packing nut). Also check tightness whenever unit is transported.
- Recommend that you replace metering valve packings every other time that pump packings are replaced.



Pump

See pump manual.

Turbine Alternator

Replace bearings every 2000 hours. See page 20.

Air Filters

Check daily. Drain and clean as necessary. See page 16.

Pump Test

Follow this procedure the first time system is operated (after flushing and priming) and whenever you need to check whether pumps are on ratio.

The following table shows the volume dispensed during the pump test, based on your pump ratio. Dispense into a container with adequate graduations.

Pump	Volume Dispensed
45:1	750 cc
56:1	660 cc
68:1	540 cc
80:1	435 cc

1. Turn knob to pump test . Turn off air regulator. Open main air shutoff valve. Adjust air pressure to 50 psi (0.35 MPa, 3.5 bar).

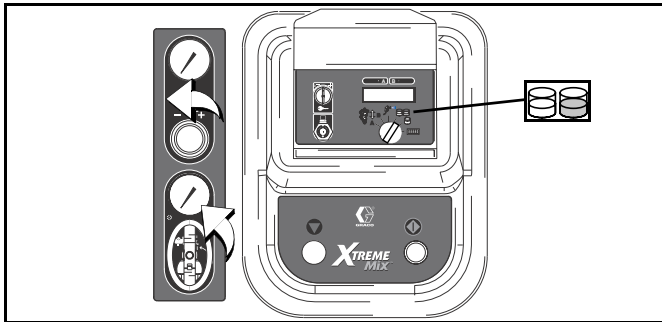

2. Dispense fluid A:

- a. Close fluid shutoff valves and sampling valves A and B.
- b. Place a clean 1 quart (1000 cc) container under sampling valve A.

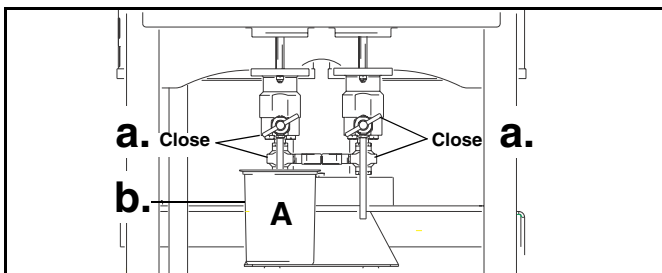

- c. Press Start . Pump A light comes on.
- d. Slowly open and adjust sampling valve A to achieve desired flow. The pump stops automatically when dispense is complete. Pump A light turns off, Pump B light comes on.

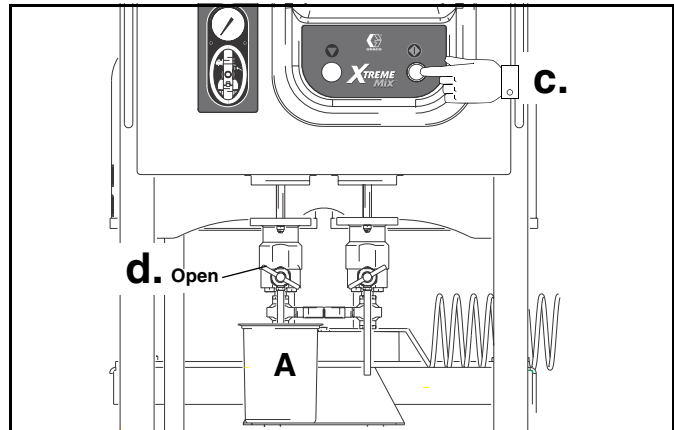

3. Close sampling valve A.

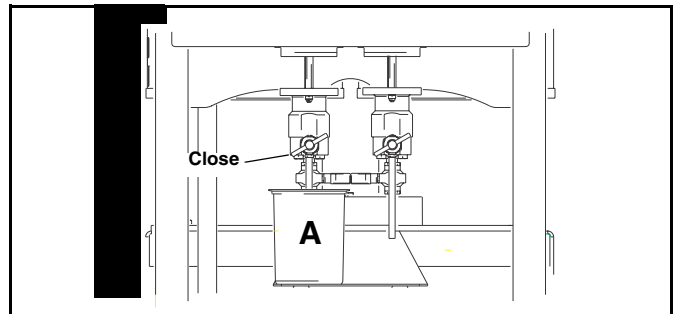

4. Dispense fluid B as follows:

- a. Place a clean 1 quart (1000 cc) container under sampling valve B.
- b. Slowly open and adjust sampling valve B to achieve desired flow. The pump stops automatically when dispense is complete. Pump B light turns off.

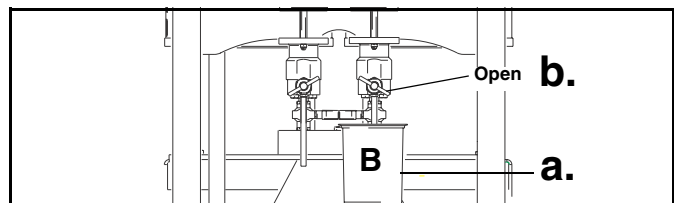

5. Close sampling valve B.

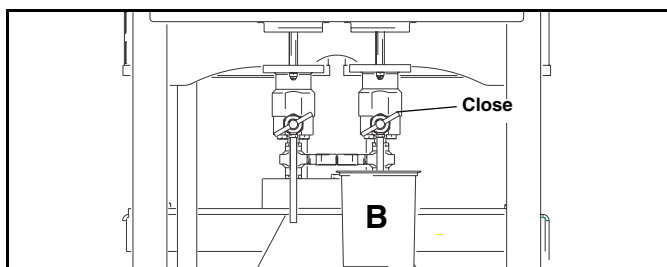

6. Compare fluid amounts in the containers; they should be equal. Repeat test if fluids are not equal. If problem still persists, see **Troubleshooting**, page 12.

Troubleshooting

WARNING









Read warnings, page 5.

 If an error code displays, see page 15.

Problem	Cause	Solution
Display not lit. No electric power.	Air valve not turned on.	Turn on main air valve to system.
	Air supply pressure too low.	Increase pressure to 50 psi (0.35 MPa, 3.5 bar) or greater.
	Air supply filters plugged.	Clean filter bowls; replace filter elements. Page 16.
	Turbine air regulator set too low.	Adjust to proper setting.
	Turbine alternator failure.	Repair or replace turbine. Page 20.
	Power supply not connected to main board.	Check power connections to main board. See Electrical Schematic , page 28.
	Main board not connected to display board.	Check electrical connections between display and main board. See Electrical Schematic , page 28.
Pumps do not run.	Display board failure.	Replace display board. Page 18.
	Knob set to cycle counter 	Set knob to desired setting.
	Air pressure to pumps too low	Increase pressure to 50 psi (0.35 MPa, 3.5 bar) or greater.
	Air pilot lines are obstructed	Check pilot lines for kinks or pinches.
	Solenoid valve stuck.	Actuate solenoid manually, if it does not operate, replace solenoid. Page 21.
	Air pilot valve(s) to motor stuck.	Replace valve(s). Page 22.
Pump test volume is not correct.	Metering valve(s) not opening.	Service or replace valve(s). Page 24.
	Air pressure to pumps too low	Increase pressure to 50 psi (0.35 MPa, 3.5 bar) or greater.
	Sensors not functioning properly.	Check position of sensors. See page 27. Check board calibration and recalibrate if necessary. See page 19. Replace sensors. Page 27.
	Pump cavitating excessively.	Check for air in lines caused by loose fitting or use of agitator. Material too viscous. Use heater.

Problem	Cause	Solution
Paint does not cure consistently.	Ratio not set correctly.	Check that correct ratio is set and set by volume. See Xtreme Mix Operation manual.
	Material not mixing correctly.	Test pump. Page 10. Make sure mixer is clean; flush as needed. See Xtreme Mix Operation manual.
	Pump not operating correctly.	Observe whether pumps are loading and checking correctly, if not, clean and repair pump. See pump manual.
Poor spray pattern.	Fluid pressure too low.	Increase pump pressure.
	Spray tip dirty or worn.	Relieve pressure. Clean or replace tip. Follow gun manual instructions.
	Fluid A or B filters plugged.	Clean filters. See pump manual.
	Mixer or hoses partially plugged or too restrictive.	Inspect parts for cured material. Clean or replace, or use larger hoses and mixer.
System runs erratically.	Air filter(s) clogged. Replace elements.	Clean. Replace element(s). See page 16.
	Air supply hoses undersized.	Replace hoses with appropriate size.
	Air compressor undersized.	Use larger air compressor.
	Air supply pressure tank undersized.	Use larger pressure tank.
Air supply relief valve opens.	Turbine air regulator set too high.	Lower setting to 23-25 psi (172-241 kPa, 1.7-2.4 bar).
Turbine alternator makes high-pitched whining noise.	Turbine bearings worn. (Setting turbine air regulator too high, wears bearings.)	Replace bearings. Page 20.
Display shows 88888 or unit reboots unexpectedly.	Turbine is not supplying enough power to board.	Increase turbine regulator setting to 23-25 psi (172-241 kPa, 1.7-2.4 bar).
		Check turbine and electrical control exhaust air for restrictions.
		Replace turbine bearings. Page 20.
Xtreme Mix does not start when start button is pressed.	Faulty start switch or wire harness.	Check start switch and wiring harness continuity; switch is normally open circuit. See Electrical Schematic , page 28.
	Faulty stop switch or wiring harness.	Check stop switch and wiring harness continuity; stop switch is normally closed circuit. See Electrical Schematic , page 28.
	Bad I/O port on main board.	Replace board. Page 17.
Fluid valves leaking.	Loose or worn packings.	Tighten packing nut. If leak continues, replace packings. Page 24.

Problem	Cause	Solution
Flow rate too low.	Inadequate air supply.	Use larger CFM compressor.
	Air pressure to pumps too low.	Increase pressure.
	Fluid A or B filters plugged.	Clean filters. See pump manual.
	Spray tip too small.	Relieve pressure. Install larger tip. Follow gun manual instructions.
	Mixer or hoses partially plugged or too restrictive.	Inspect parts for cured material. Clean or replace, or use larger hoses and mixer.
Pump stops after 12 cycles.	Knob is set to Run pump A  or B  independently.	Turn knob to spray  if spraying material.
Xtreme Mix makes chirping noise every 60 seconds.	Knob is set to Run pump A  or B  independently.	Turn knob to spray  if spraying material.
	Material too heavy to siphon or gravity feed.	Change material feed/supply method.

Alarms



- An alarm condition will shutdown the equipment.
 - A chirping sound every 60 seconds indicates the unit is set for recirculation mode.
- * Indicates error where audible alarm sounds once briefly.
 ** Indicates error where audible alarm sound pulses.

Code	Alarm	Active	Problem	Cause
01	Sensor Error A*	Always	No signal from pump A sensor.	Loose cable, failed sensor or cable. Page 27.
02	Sensor Error B*	Always	No signal from pump B sensor.	Loose cable, failed sensor or cable. Page 27.
03	Controller Error*	Always	Loss of communication between main and display boards.	Loose cable, failed board. Page 17.
04	Pump Runaway A**	Spray Test Batch	Pump running too fast.  This alarm is not active when pumps are run independently.	Empty fluid reservoir(s). Clogged fluid filter. Hose rupture after mix manifold. Sampling valve open too far. Excessive cavitation.
05	Pump Runaway B**			
06	Pump Error A**	Spray Test Batch	Pump does not stall after top change over. Pump cavitating excessively.	Foot valve leak. Air in lines caused by loose fitting or use of agitator. Empty fluid reservoir(s).
07	Pump Error B**			
08	Sensor Code Error	Always	Software boot, sensor values reverted to default.	Sensor value data corrupt; board needs replacement and /or recalibration. Page 17-19.
09	Metering Error A**	Spray	A dose too great.	Metering valve A leak. Page 24. Empty B fluid reservoir.
10	Metering Error B**	Spray	B dose too great.	Metering valve B leak. Page 24. Empty A fluid reservoir.
11	Sensor Reading Low A*	Always	Pump stroke travels beyond sensor range at bottom change over.	Sensor or bracket loose. Page 27.
12	Sensor Reading Low B*			Sensor magnet dirty.
13	Sensor Reading High A*	Always	Pump stroke travels beyond sensor range at top change over.	Sensor or bracket loose. Page 27.
14	Sensor Reading High B*			Sensor magnet dirty.
15	Piston packing/ball A*	Test	Pump does not completely stall in up stroke.	Piston packing or ball check failure.
16	Piston packing/ball B*			
17	Inlet Ball A*	Test	Pump does not completely stall in down-stroke.	Foot valve ball check failure.
18	Inlet Ball B*			
19	Metering Valve A*	Test	Pump does not completely stall in both up and down strokes.	Throat packing or metering valve failure. Page 24.
20	Metering Valve B*			

Repair

Follow **Shutdown** procedure, page 9, if service time may exceed pot life time, before servicing fluid components, and before transporting equipment to a service area.

WARNING



Read warnings, page 5.

Replacing Air Filter Element

There are 2 air filters on the unit: the 5 micron air manifold filter (518) and 40 micron pump air filter (8). Check filters daily and replace element as needed.

WARNING



Removing the bowl of a pressurized air filter could cause serious injury. Do not service air filter until air line is depressurized.

Both Filters

1. Close main air shutoff valve on air supply line and on unit. Depressurize air line.

Air Manifold Filter

2. Remove air manifold cover (42). FIG. 3.

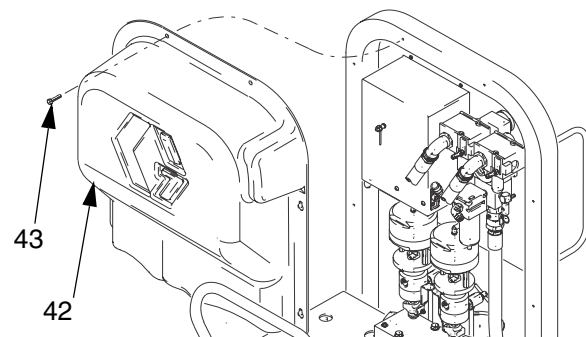

FIG. 3

3. Unscrew filter bowl. FIG. 4.



FIG. 4

4. Remove and replace element.
5. Screw filter bowl on securely.

Pump Air Filter

2. Unscrew filter bowl. FIG. 5.



FIG. 5

3. Unscrew plate.
4. Remove and replace element. FIG. 6.



FIG. 6

5. Reassemble.

User Interface

Removing Cover

1. Close main air shutoff valve on air supply line and on unit.
2. Remove air manifold cover (42). FIG. 3, page 16.
3. Remove four nuts (32) and open user interface cover (4). FIG. 7–FIG. 8.



FIG. 7

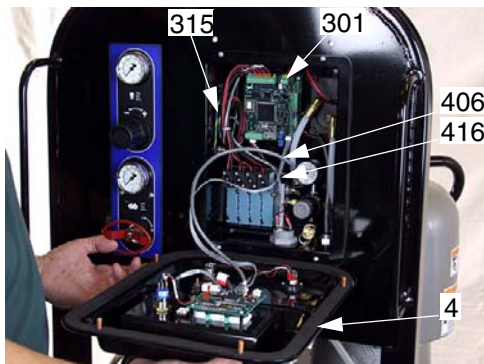

FIG. 8

4. To completely remove cover (4), disconnect ground wire (315), wires (416 and 406) from main board (301). See FIG. 8 and **Electrical Schematic**, page 28.

Software Upgrades

⚠ CAUTION

To avoid damaging circuit board, wear a grounding strap.

1. Remove User Interface cover. See above.
2. Use a chip remover (D) to remove software chip (C). FIG. 9.

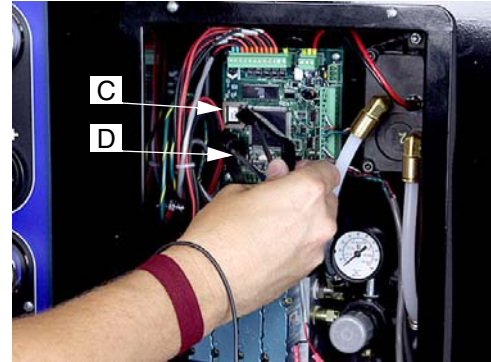

FIG. 9

3. Install new chip (beveled corner down).
4. Reassemble.
5. Recalibrate main circuit board. See page 19.

Replacing Main Circuit Board

⚠ CAUTION

To avoid damaging circuit board, wear a grounding strap.

1. Remove User Interface cover. See above.
2. Disconnect all wire connectors from board (301). FIG. 10.
3. Remove four screws (302) and replace board (301).
4. Reassemble. Refer to **Electrical Schematic**, page 28.
5. Recalibrate main circuit board. See page 19.

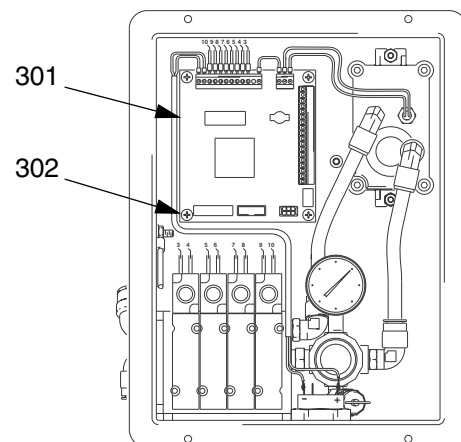

FIG. 10

Replacing Display Circuit Board

⚠ CAUTION

To avoid damaging circuit board, wear a grounding strap.

1. Remove User Interface cover. See page 17.
2. Disconnect wires from display board (410). FIG. 11.
3. Remove two screws (411).
4. Remove setscrew (B) from knob (405) and remove knob assembly.
5. Remove and replace display board (410).
6. Reassemble. Refer to **Electrical Schematic**, page 28.

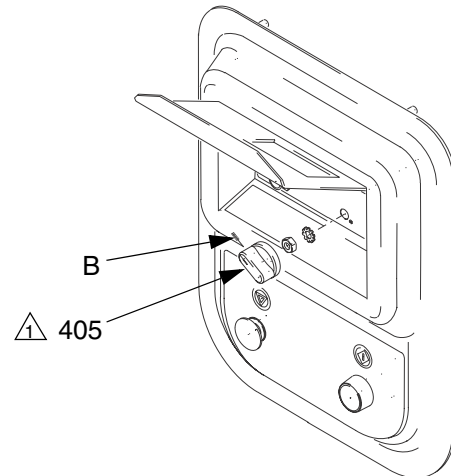
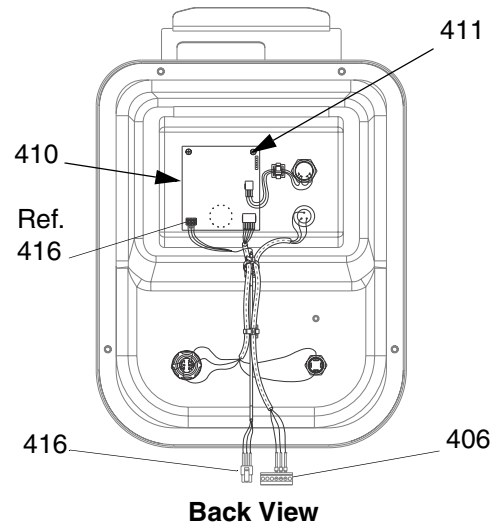





⚠ Align knob to allow for turning to all 6 settings.

FIG. 11

Recalibrate Circuit Board

Follow this procedure whenever the main circuit board, software, or sensor is replaced, or when Alarm 8 occurs (refer to page 15).

1. Note calibration value on pump A sensor. Refer to FIG. 23, page 27.
2. Open main air valve to start unit.
3. Turn knob to pump A . FIG. 12. Hold down Stop  button about 5 seconds. The default calibration (number between 85000 - 95000) displays.
4. Use key (X) to change default to calibration value noted previously.
5. Note calibration value on pump B sensor.
6. Turn knob to pump B . Hold down Stop  button about 5 seconds. The default calibration displays.
7. Use key (X) to change default to calibration value noted previously.

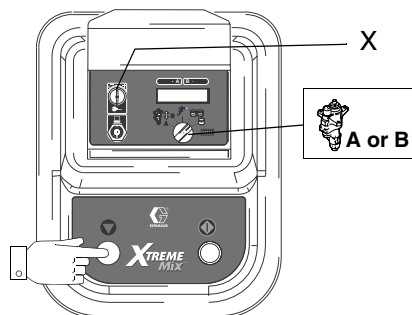

FIG. 12



If data download is used, set date and time after calibrating, using Xtreme Mix software.

Pneumatic Control

Alternator Repair

Turbine Alternator Repair Kit 223688 is available to replace turbine bearings.

1. Remove User Interface cover. See page 17.

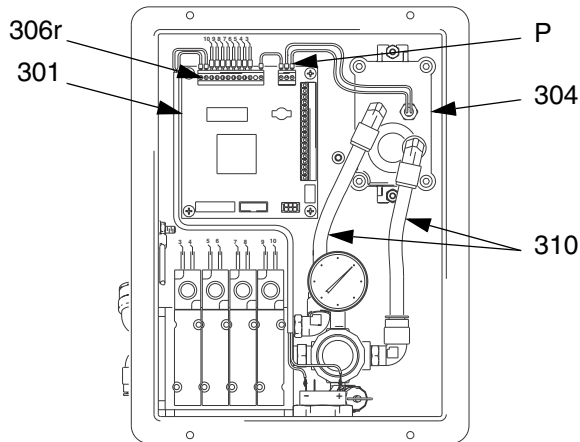

FIG. 13

2. Disconnect power supply wires (P). FIG. 13.
3. Disconnect two air lines (310) from alternator (304). FIG. 14.
4. Remove top nut (305) and loosen bottom nut. Slide alternator up and off bottom nut.
5. Remove four screws (304d) to separate alternator housings. FIG. 15.
6. Disconnect turbine (304e) from board (A). Follow instructions in turbine kit manual 308034 to remove and repair turbine.
7. Replace gasket (304a) if damaged. Place between housings before securing with screws (304d).
8. Reassemble. Refer to **Electrical Schematic**, page 28.

- Lightly lubricate turbine o-ring before installing turbine in housing.
- Connect alternator red wire to + side and black wire to – side of main circuit board.
- Connect turbine to 3-pin connector on main circuit board.

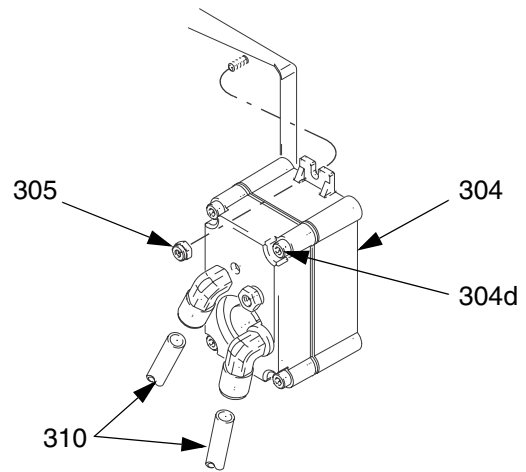
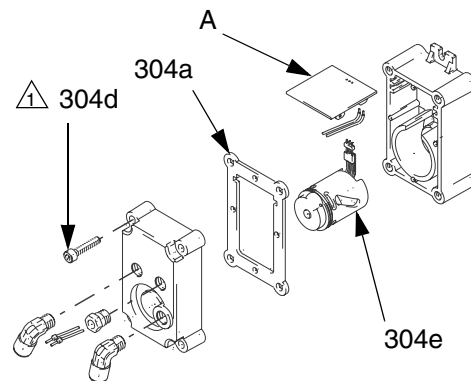

FIG. 14



Torque to 20 in-lbs (2 N•m)

FIG. 15

Replacing Solenoids

Follow this procedure to replace a single solenoid.

1. Remove User Interface cover. See page 17.
2. Disconnect two solenoid wires (V) from main board. FIG. 16.
3. Remove two screws (S).
4. Remove and replace solenoid (306b).



From left to right, solenoid functions are as follows:

- Metering valve A
- Metering valve B
- Pump A
- Pump B

5. Reassemble. Solenoid wires are polarized (red +, black -). Refer to **Electrical Schematic**, page 28.

Replacing Alternator Regulator

1. Remove User Interface cover. See page 17.
2. Remove two screws (309). FIG. 16.

3. Disconnect supply and exhaust air lines (310).
4. Disconnect solenoid wires 12 position Phoenix connector (306r) from main board. FIG. 13, page 20.
5. Remove solenoid module (306) with regulator (306e). FIG. 16.
6. Unscrew and replace regulator (306e).
7. Reassemble. Refer to **Electrical Schematic**, page 28.



Make sure gaskets (306j, 306k) are in place when reinstalling solenoid module.

8. Set regulator to 24 psi (160 kPa, 1.6 bar).

Replacing Alarm

1. Remove User Interface cover. See page 17.
2. Disconnect alarm wires from main board.
3. Unscrew alarm (313) and replace. FIG. 16.
4. Reassemble. Refer to **Electrical Schematic**, page 28.

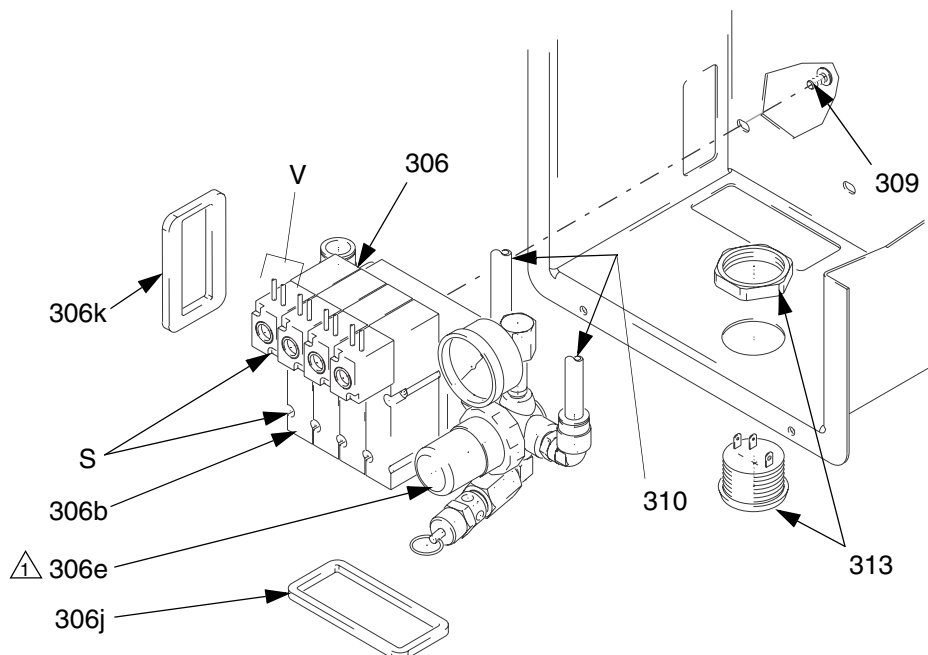

Set regulator pressure to 24 psi (160 kPa, 16 bar)

FIG. 16

Pump Air Manifold

1. Close main air shutoff valve on air supply line and on unit.
2. Pull off regulator knob (R). FIG. 17.
3. Remove two screws (44).
4. Disconnect two hoses (515) from pump motors.
5. Replace parts as needed. See page 40.
6. Reassemble.

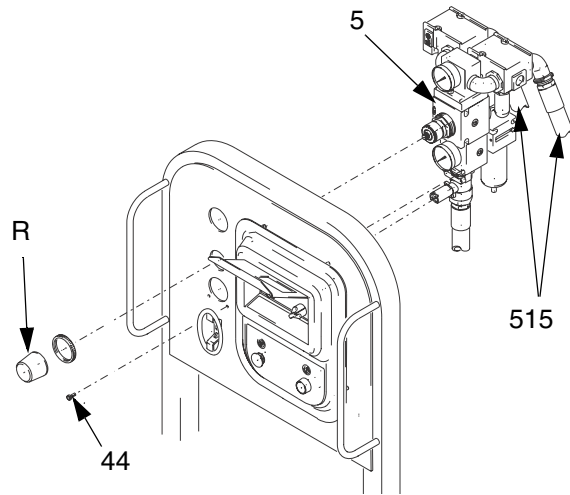



FIG. 17

Sampling Valve

⚠ WARNING

Read warnings, page 5.

1. Follow **Pressure Relief Procedure**, page 7.
2. Unscrew sampling valve assembly (83) from metering valve (601).
3. Unscrew seat (83c).
4. Remove o-rings (83f), ball (83d), seat (83g), and gasket (83h).
5. Replace parts as needed and reassemble.

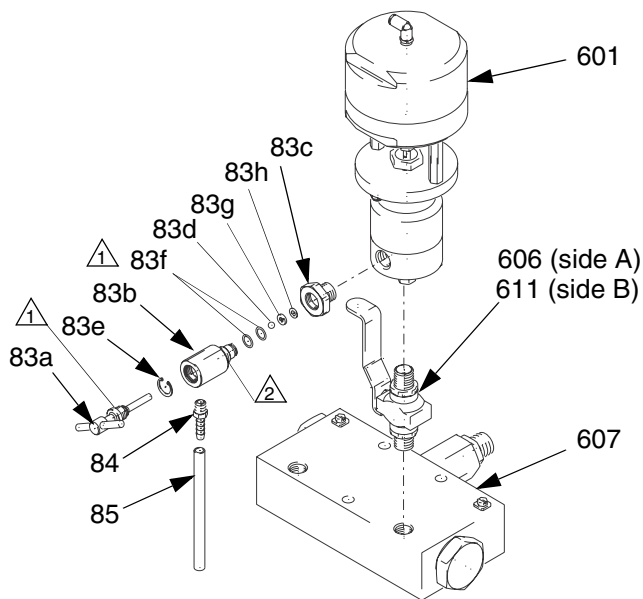

 Lubricate.

 Apply anaerobic sealant. Torque to 130-140 in-lbs (15-16 N•m)

FIG. 18

Metering Valve/Manifold Assembly

WARNING

Read warnings, page 5.

Removing Assembly

1. Follow **Pressure Relief Procedure**, page 7.
2. Disconnect top and bottom black air tubes.
3. Unscrew fluid tube.
4. Remove nuts (26), screws (27, 48) and lockwashers (25). FIG. 19.
5. Remove metering valve manifold (6).

Removing Metering Valve

1. Remove **Metering Valve/Manifold Assembly**.
2. Unscrew metering valve (601) from shutoff valve (606 or 611).
3. If necessary, remove and repair or replace shutoff valve (606 or 611). See manual 306861.

Servicing Metering Valve

Follow this procedure to replace packings. Reference numbers with * are included in repair kit 234098. Reference numbers with † are included in repair kit 234131.

1. Remove metering valve.
2. Remove two locknuts (636). FIG. 20.
3. Remove packing nut (627).
4. Remove inlet housing (628).
5. Unscrew needle (630*) from piston rod (625).
6. Remove packings (637*, 638, 639*). Inspect needle (630*) and replace if worn.

If piston valve packings need replacement:

7. Unscrew cap (622).
8. Unscrew locknut (631).
9. Remove piston (623) and replace o-rings (632*†, 633*†, 634*†).
10. Replace piston rod o-ring (643*†) if damaged.
11. Reassemble.

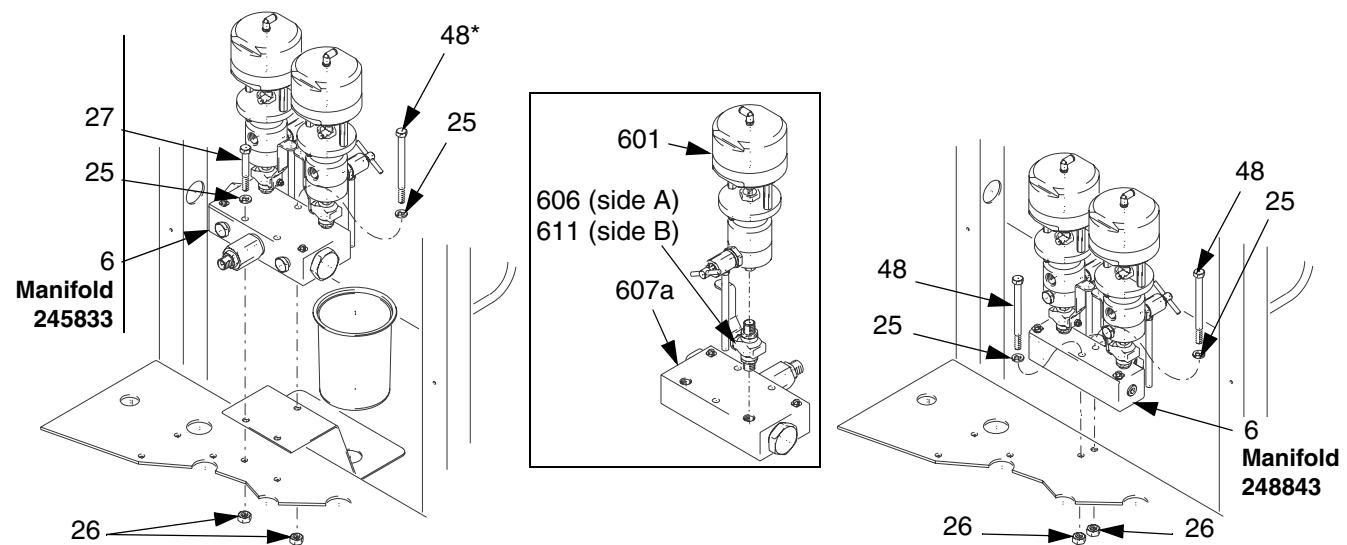
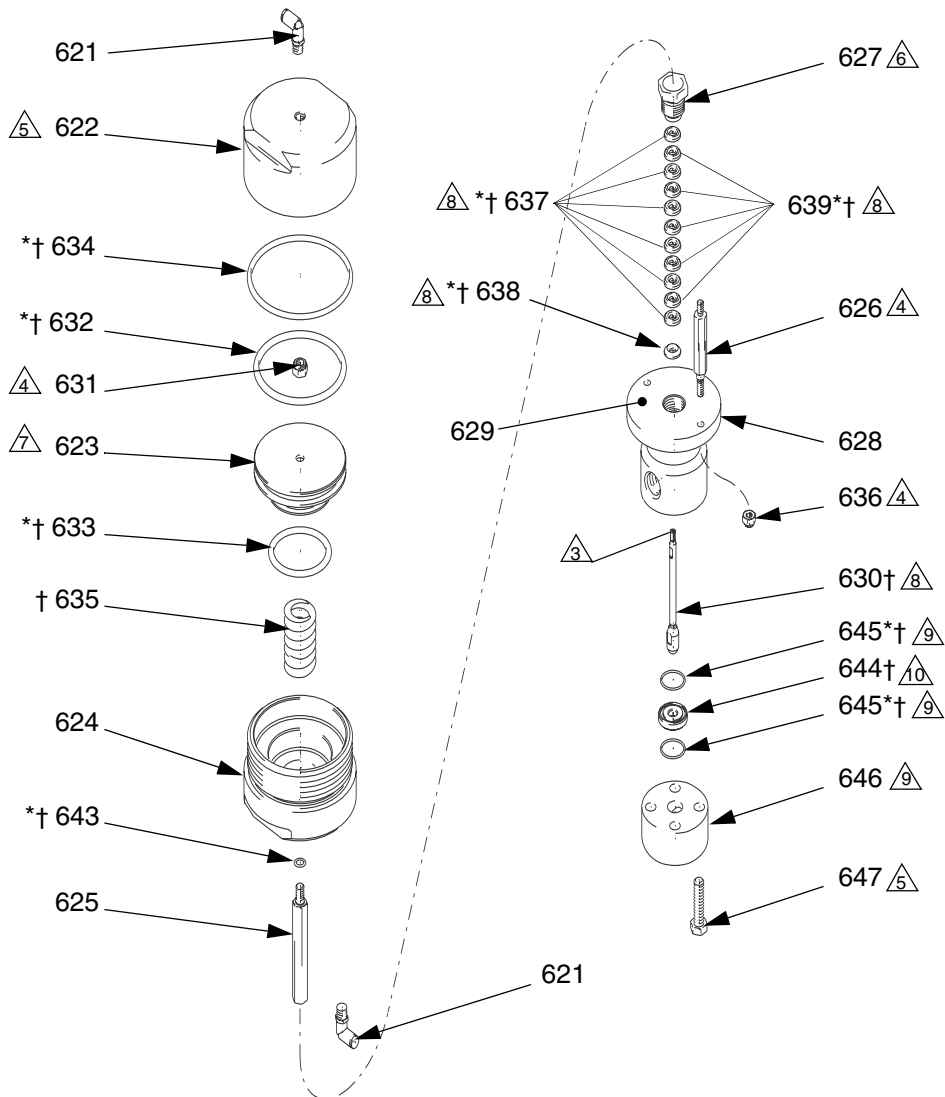

FIG. 19



1. Apply pipe sealant to non-swiveling pipe threads.
2. Apply lubricant to threads, o-rings, and seals.

△3 Apply medium anaerobic adhesive. Thread to bottom.

△4 Torque to 5-7 ft/lbs (7-9 N•m).

△5 Torque to 30-40 ft/lbs (41-54 N•m).

△6 Tighten packing nut 1/4 turn after nut bottoms out; 145-155 in/lbs (16-18 N•m). Check packing nut tightness about once a month. Keep packing nut filled with TSL.

△7 Lubricate and press piston evenly into cylinder.

△8 Clean needle (630) and packing cavity before reinstalling packings (637*, 638, 639*). Lubricate packings and install with lips facing up toward packing nut (627) in order shown.

△9 Whenever the seat housing (646) is removed, replace the o-rings (645).

△10 Inspect reversible seat for damage. If one side is worn, reverse seat.

FIG. 20

Servicing Fluid Manifold 245833

Follow this procedure to replace packings. Reference numbers with * are included in repair kit 234100.

1. Remove metering valve. See page 24.
2. Unscrew plug (661).
3. Remove and replace o-rings (662*, 663*, 665*), seat (664*), ball (666*), and spring (667*).
4. Reassemble.

CAUTION

Do not assemble static mixer directly to fluid manifold. Install static mixer after first 50 ft. (15 m) of hose to ensure material is completely mixed. Spraying unmixed material could necessitate rework of part sprayed. See **Setup** in Xtreme Mix Operation manual.

Servicing Fluid Manifold 248843

There are no serviceable parts on manifold 248843.

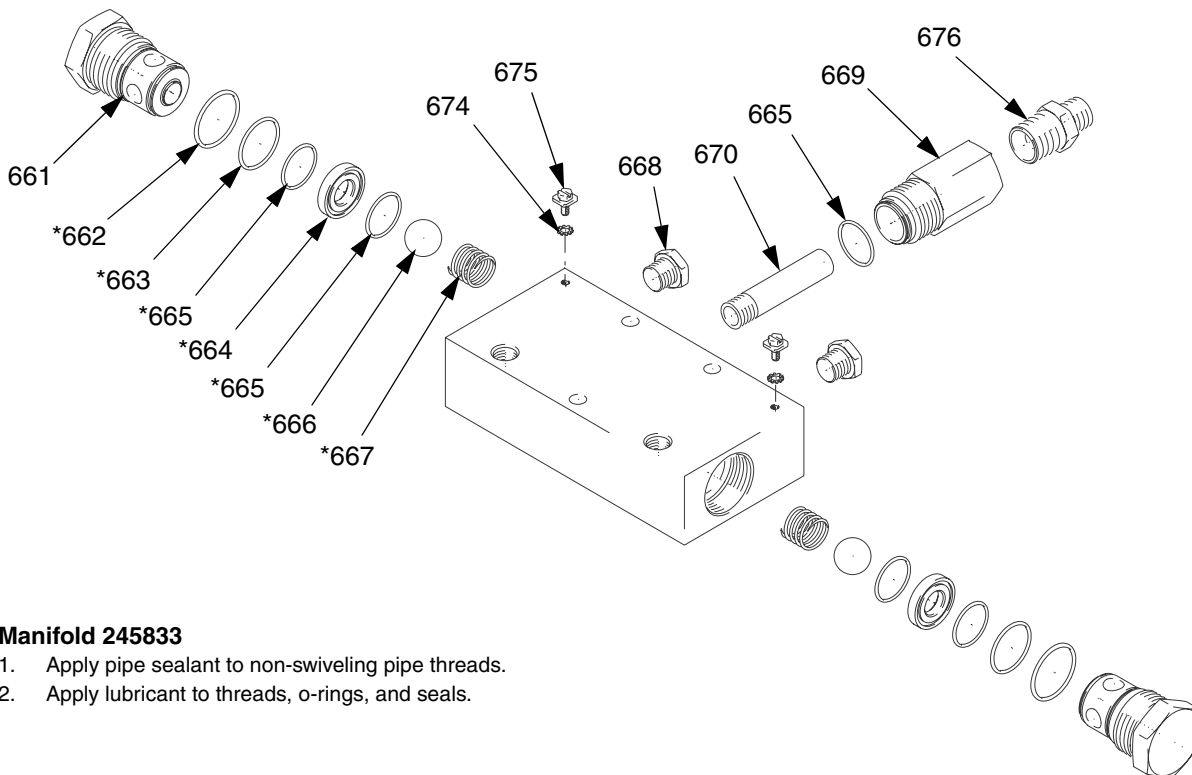

Manifold 245833

1. Apply pipe sealant to non-swiveling pipe threads.
2. Apply lubricant to threads, o-rings, and seals.

FIG. 21

Sensor

CAUTION

To avoid damaging board, wear a grounding strap.

Reference numbers with * are included in repair kit 246345. Reference numbers with † are included in repair kit 246344.

1. Close main air shutoff valve on air supply line and unit. FIG. 22.

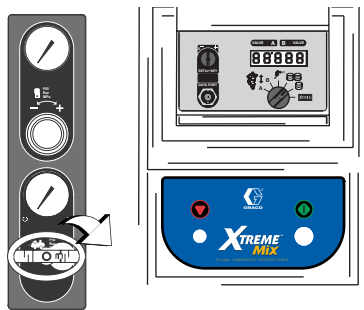

FIG. 22

2. Unscrew sensor cap (701†) from nut (712†). FIG. 23.
3. Disconnect cable (705*).
4. Unscrew fitting (713*), locknut (719*), and cover (702*).
5. Disconnect sensor cable (Y) from board (703†).
6. Remove and replace parts as needed.
7. Reassemble and mount sensor. Refer to **Electrical Schematic**, page 28.



Mount sensor as close to magnet as possible without touching it.

8. Recalibrate main circuit board. See page 19.

Displacement Pump

WARNING



Read warnings, page 5.

1. Follow **Pressure Relief Procedure**, page 7.

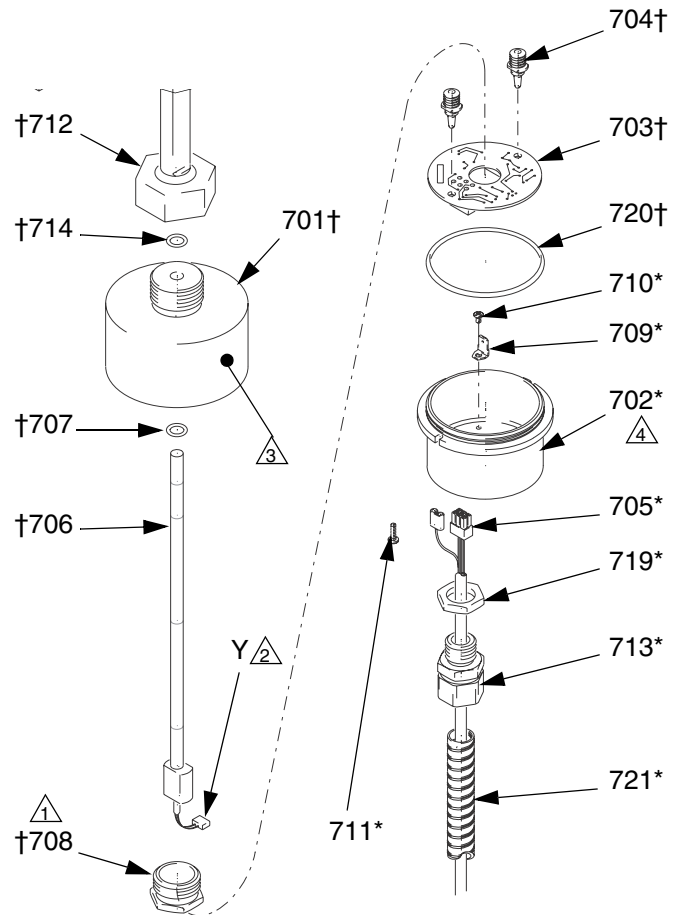

△1 Torque to 60 in-lbs (7 N•m).

△2 Plug connector into connector on board (703).

△3 Calibration value location.

△4 Before assembling cover (702*) to cap (701†), assemble cable (705*) through fitting (713*) and cover (702*), and plug cable into connector on board (703†) and to ground lug.

FIG. 23

2. Disconnect 90° swivel (30) from pump lower. Refer to page 32.
3. Remove pump lower and service as instructed in pump manual 311762.

Electrical Schematic

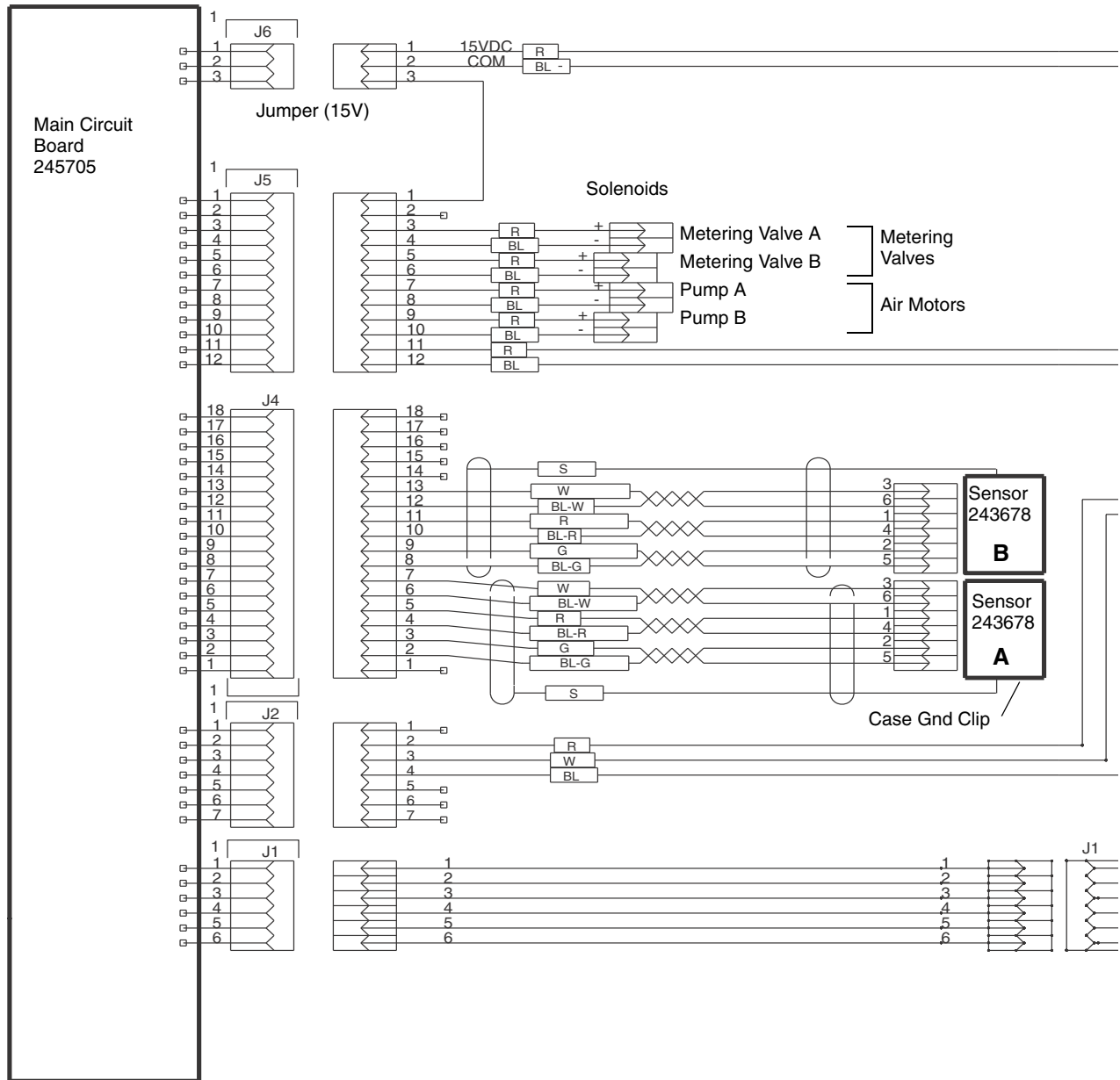

Key:

BL Black
BR Brown
BL-G Black with green
BL-R Black with red

BL-W Black with white
G Green
GND Ground
R Red

S Shield
W White

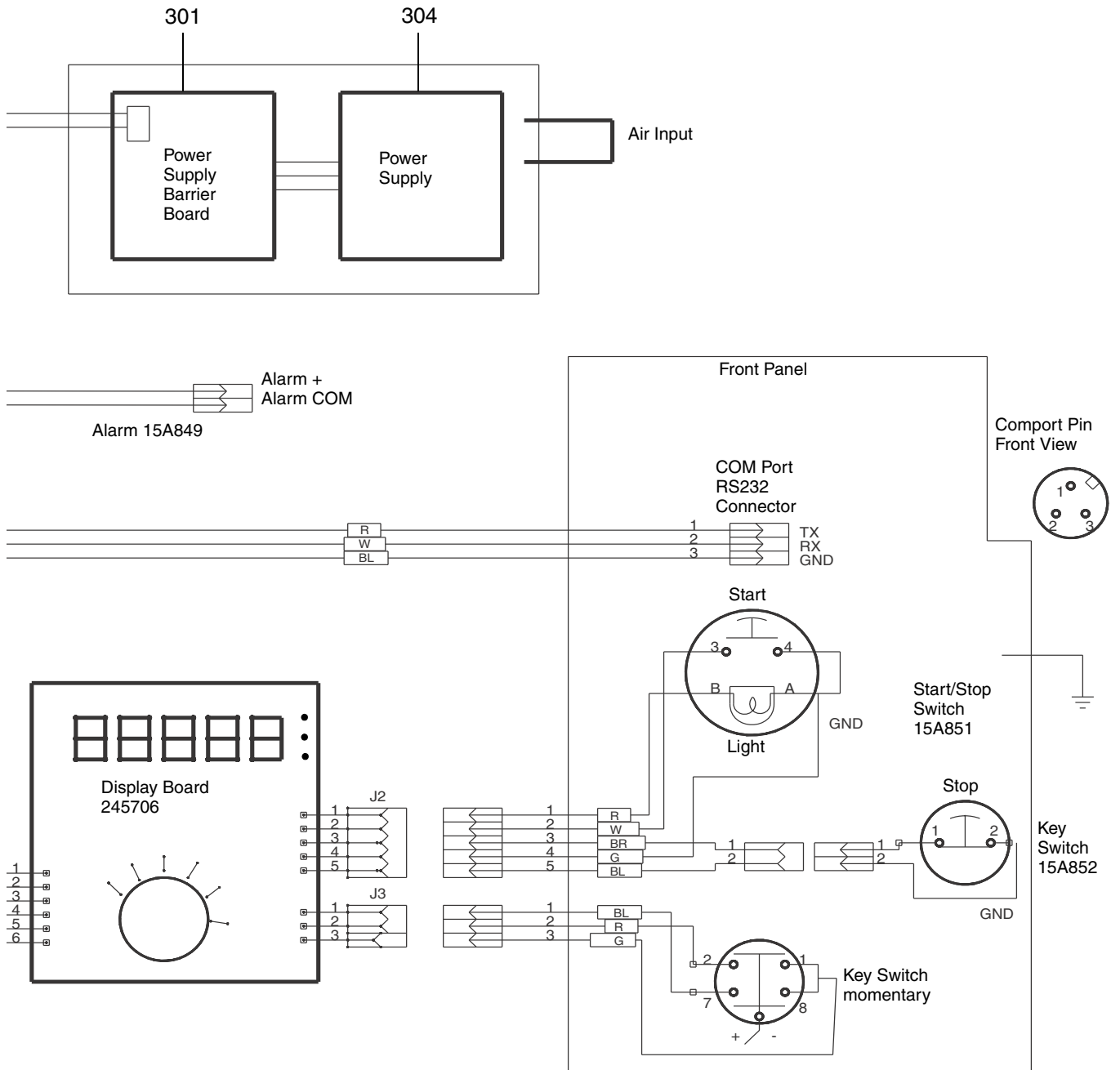

Pneumatic Schematic

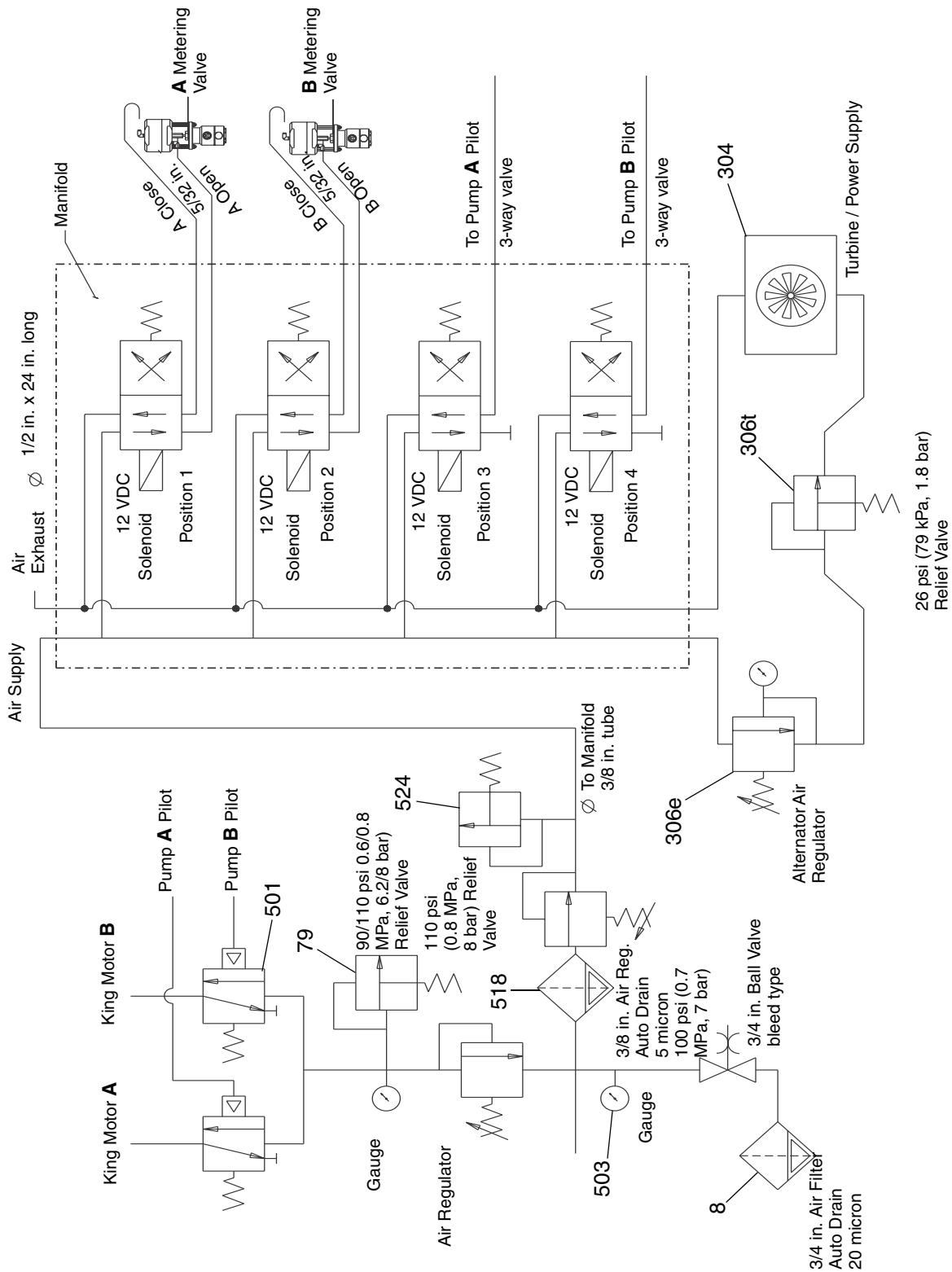
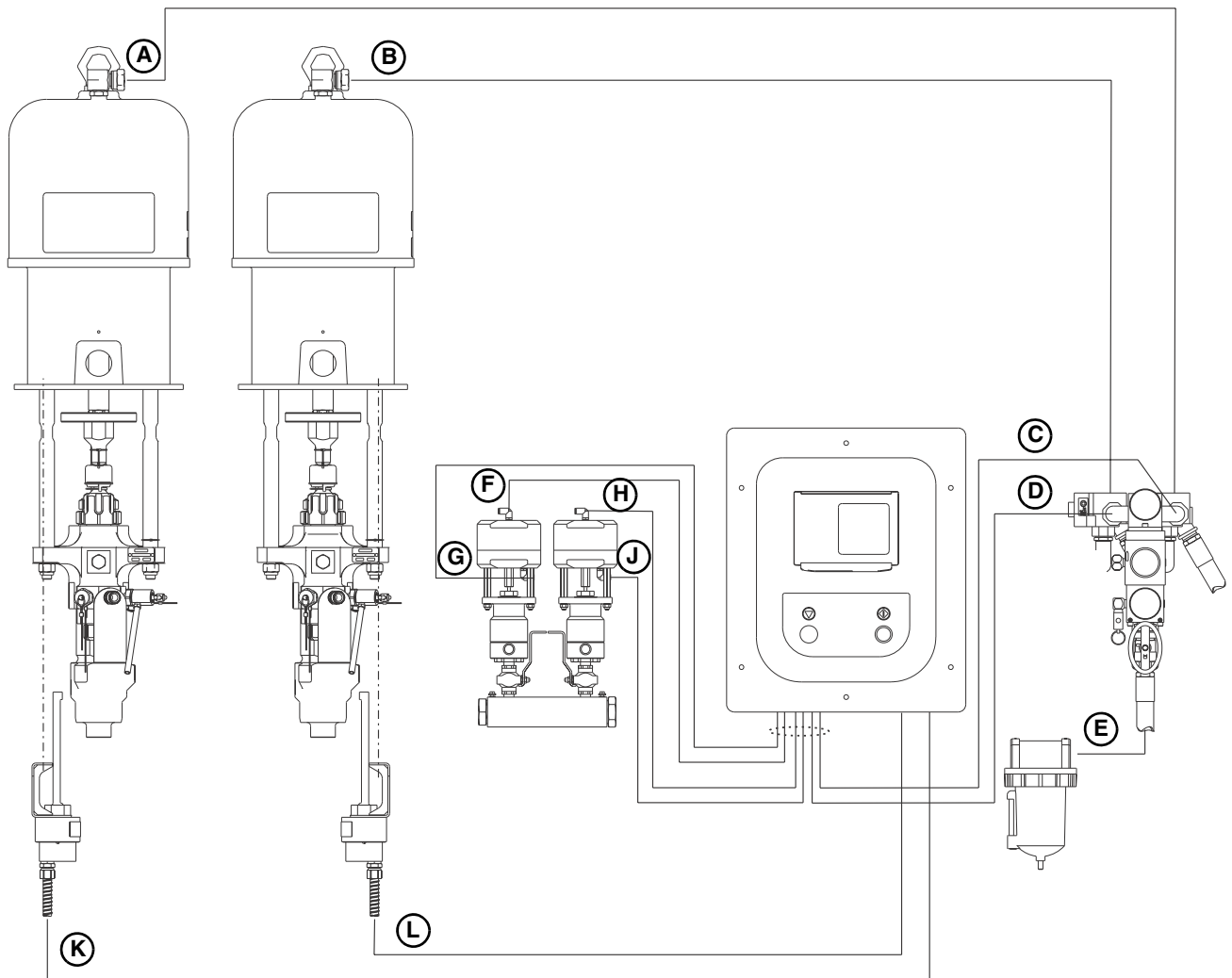

FIG. 24

Pneumatic/Sensor Connections

Key:

- A Pump A Air
- B Pump B Air
- C Pump A Pilot Air
- D Pump B Pilot Air
- E Air Supply
- F Metering Valve A - CLOSE
- G Metering Valve A - OPEN
- H Metering Valve B- CLOSE
- J Metering Valve B- OPEN
- K Sensor A Cable
- L Sensor B Cable

FIG. 25

Parts

Xtreme Mix Proportioner

Parts shown here and page 34 and 36.

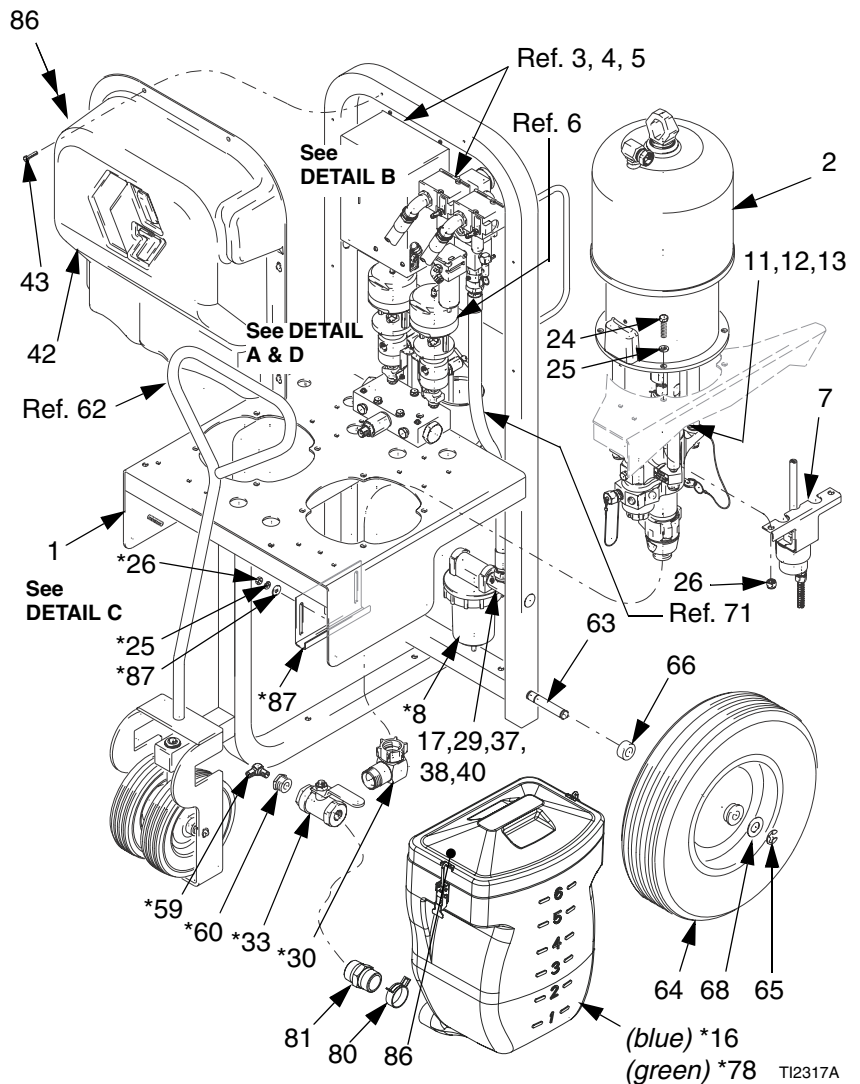
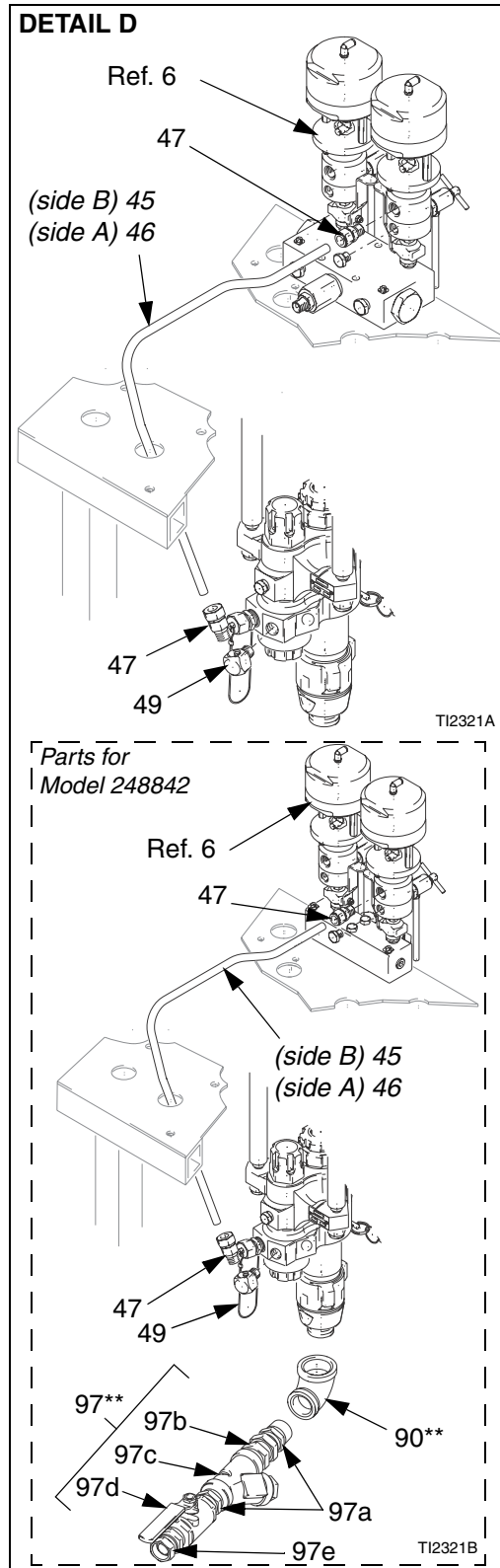

Xtreme Mix Proportioner



Refer to page 3 for additional model information.

Part Number Table

Approved for Non-hazardous Location								
Xtreme Mix	Pump (2)	Metering Valve (6)	Gun (15)	Hose (20)	Coupling (56)	Relief Valve (79)	Tube (45)	Tube (46)
233863	249274 (45:1)	245824	XTR704	H53850	15B729	113498	15A914	15A915
233864	249275 (56:1)	245824	XTR704	H53850	15B729	113498	15A914	15A915
233865	249276 (68:1)	245824	XTR704	H73850	15B729	113498	15A914	15A915
233866	249277 (80:1)	245824	XTR704	H73850	15B729	116643	15A914	15A915
233867	249278 (45:1)	245824	XTR704	H53850	15B729	113498	15A914	15A915
233868	249279 (56:1)	245824	XTR704	H53850	15B729	113498	15A914	15A915
233869	249280 (68:1)	245824	XTR704	H73850	15B729	113498	15A914	15A915
233870	249281 (80:1)	245824	XTR704	H73850	15B729	116643	15A914	15A915
248842	249276 (68:1)	248843	none	none	none	108124	15A914	15A915

Ref. No.	Part No.	Description	Qty.	Ref. No.	Part No.	Description	Qty.
1	245997	CART	1	38	100721	PLUG; 1/4 nptf	1
2	see table, page 33	PUMP; see manual 311762 for parts	2	39	101566	LOCKNUT, not shown	1
3	245803	PNEUMATIC CONTROL; parts page 37	1	40‡		PLUG	1
4	245804	USER INTERFACE; parts page 39	1	42	15B281	COVER	1
5	245802	PUMP AIR MANIFOLD; parts page 40	1	43	112774	SCREW, 1/4-20	6
6	245824	METERING VALVE MANIFOLD; see table, parts page 41	1	44	103196	SCREW, #8-32 x 0.44 in.	6
	248843	METERING VALVE MANIFOLD; see table, parts page 41; used on model 248842 only	1	45	see table, page 33	TUBE, pump B	1
7	245825	SENSOR; parts page 44	2	46	see table, page 33	TUBE, pump A	1
8*	117628	AIR FILTER; 3/4 npt; 40 micron	1	47	117344	FITTING; 1/2 npt(m) x 5/8 in. (16 mm) tube	4
9	244524	GROUND WIRE, with clamp; not shown	1	48	100560	SCREW; 3/8-16 UNC x 4.75 in.	1 or 2**
10*	551390	BEAKER	2	49	158683	ELBOW, 90°; 1/2 npt	2
11	15A847	MAGNET HOLDER	2	56*	15B729	COUPLING	1
12‡	15A814	MAGNET; 2.7 ft. (0.8 m)	2	see table, page 33			
13	104092	SCREW; 10-24 UNC	4	57*	H72506	HOSE, fluid; nylon; 1/4 in. (6.3 mm) ID; 1/4 npsm(fbe); 6 ft (1.8 m)	1
15*	see table, page 33	SPRAY GUN, see manual 312145	1	58*	243832	KIT, siphon hose; 1/2 npsm(f) x 1/2 npt; not shown	1
16*	234017	FLUID RESERVOIR, blue	2	59*	117525	ELBOW, 90°; 1/2 npt	1
17	C19041	WASHER	1	60*	108143	STRAINER; 16 mesh	1
18*	214954	AIR HOSE; 3/4 x 1/2 npt; 2.75 ft. (0.84 m); not shown	2	61*	C19660	FITTING; 1-1/4 x 1/2 npt; not shown	2
20*	H73850	HOSE, fluid; nylon; 3/8 in. (10 mm) ID; 3/8 npsm(fbe); 50 ft (15.2 m) long	1	62	246127	CART HANDLE	1
	H53850	HOSE, fluid; nylon; 3/8 in. (10 mm) ID; 3/8 npsm(fbe); 50 ft (15.2 m) long	1	63	15B161	AXLE	1
21*	511352	STATIC MIXER	1	64	113362	WHEEL	2
22*	150287	COUPLING; 3/8 npt	1	65	113436	RETAINING RING	3
24	100004	SCREW; 3/8 UNC	8	66	15B755	SPACER	2
25	100133	LOCKWASHER	†15	67	114552	CAP	1
26	100131	NUT; 3/8-16 UNC	†15	68	154628	WASHER	3
27*	115348	SCREW; 3/8-16 UNC x 2.75 in.	2	70	054139	TUBE, nylon; 1.5 ft. (0.46 m); 0.5 in. OD; not shown	★
28*	15A776	PLATE	1	72	101242	RETAINING RING	2
29	207675	AIR MANIFOLD	1	73	113807	WHEEL	2
30*	112580	SWIVEL, 90°; 1.25 npsm	2	74	15A912	AXLE, vertical	1
31	100016	LOCKWASHER	4	75	15A913	AXLE, horizontal	1
32	100015	NUT; 1/4-20 UNC	4	76	191824	WASHER	4
33*	117366	SHUTOFF VALVE, 3-way; 1/2 npt	2	77	15A892	BEARING, brass	2
34‡	C12508	TUBE, nylon; 3/8 in. (9.5 mm) OD; 1 ft. (0.3 m); not shown	★	78*	234097	FLUID RESERVOIR; green	1
35‡	054753	TUBE, nylon, black; 0.156 in. (4 mm) OD; 6 ft. (1.8 m); not shown	★	79	113498	SAFETY RELIEF VALVE; 110 psi (0.8 MPa, 8 bar)	1
36	15A845	LABEL, air supply pressure	1	see table, page 33			
37	100139	PLUG; 1/8 nptf	1	116643	SAFETY RELIEF VALVE; 90 psi (0.6 MPa, 6.2 bar)	1	
				see table, page 33			
				108124	SAFETY RELIEF VALVE; 75 psi (0.5 MPa, 5.2 bar)	1	
				80	124450	CLAMP	2
				81	C20490	FITTING	2

Ref. No.	Part No.	Description	Qty.	Ref. No.	Part No.	Description	Qty.
83	245143	SAMPLING VALVE; parts page 41	2	97b	160022	• UNION; 1 in. npt(m) x 1 in. npsm(m)	1
84*	116746	FITTING; 1/8 npt x 1/4 in. (6.4 mm) tube; see page 41	2	97c	110878	• STRAINER; 1 in.	1
85*	116750	TUBE, nylon; 5 in. (12.7 cm); parts page 41	2	97d	118464	• BALL VALVE; 1 in.	1
86	193185	LABEL, warning	3	97e	202965	• UNION; 1 in. npt(m) x 3/4 npsm(f)	1
87*	15C567	BRACKET, hopper	2	98	100451	COUPLING	1
88*	100132	WASHER, flat; not shown	4	99	115671	FITTING, (m) 1/8 npt	1
90**	116401	ELBOW, 90°	2	100	054123	TUBE, draining	2ft.
97**	249024	STRAINER KIT; 500 psi (3.4 MPa, 34 bar) maximum working pressure; includes items 97a-97e	2				
97a	C20490	• NIPPLE, hex; 1 in. npt	2				

* Not included with Model 248842.
 ** Included with Model 248842 only.
 ‡ Not available for order from Graco.
 ★ Order length needed from distributor.

Hose and Gun

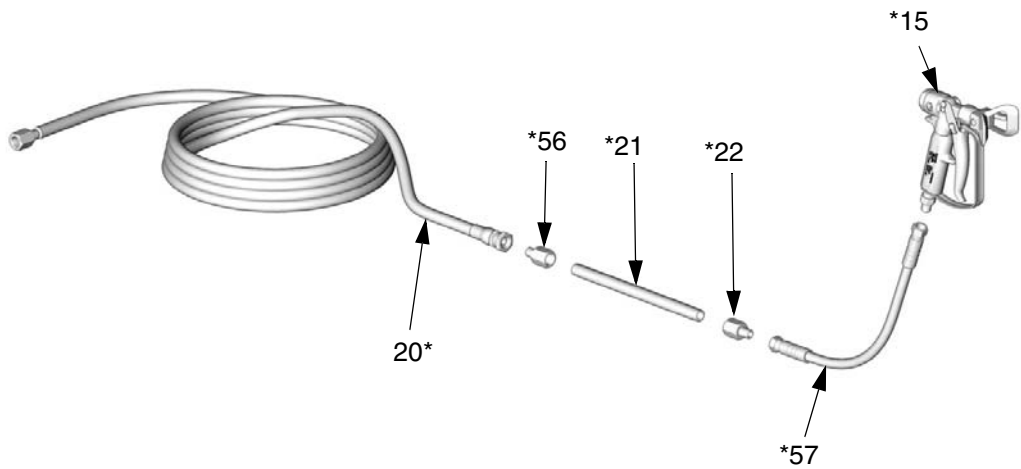

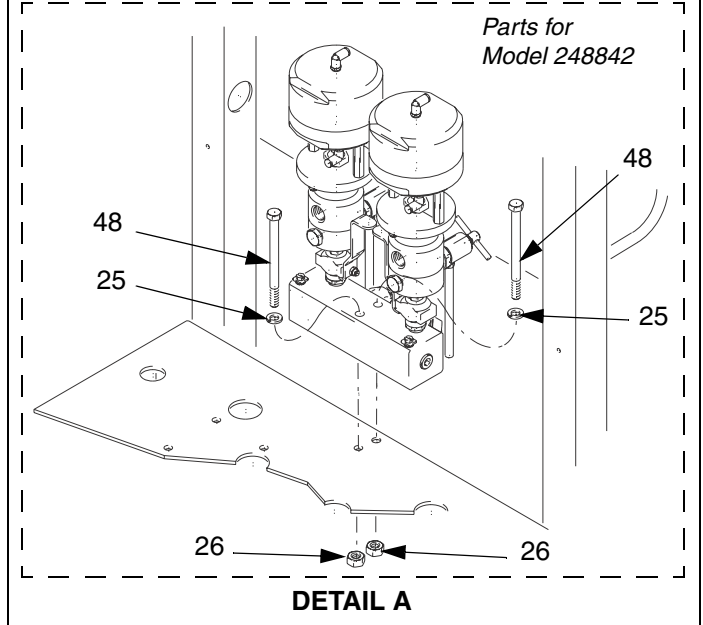
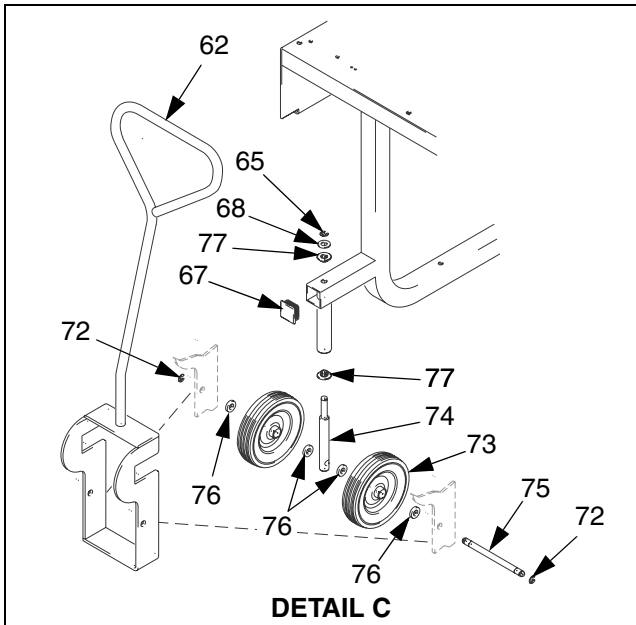
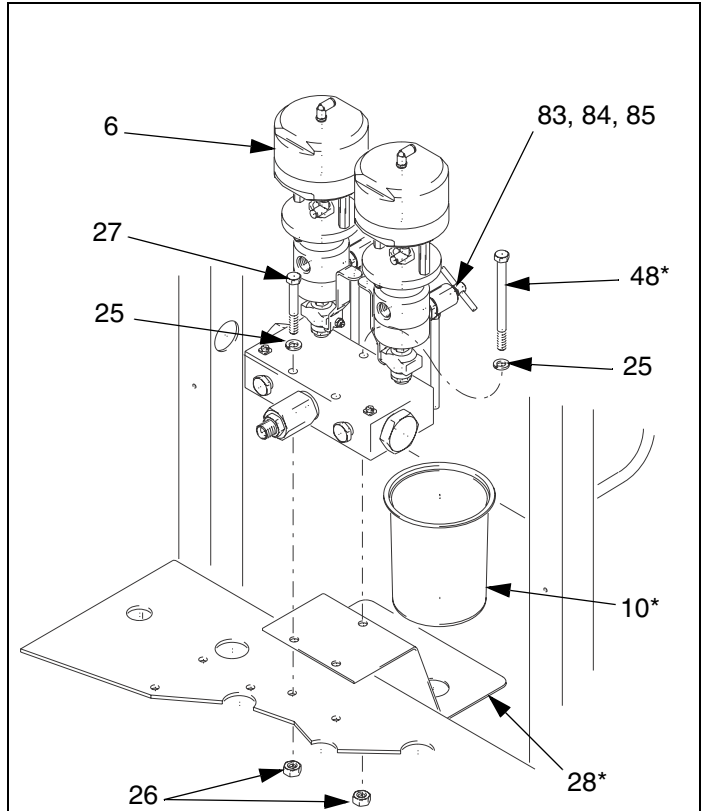
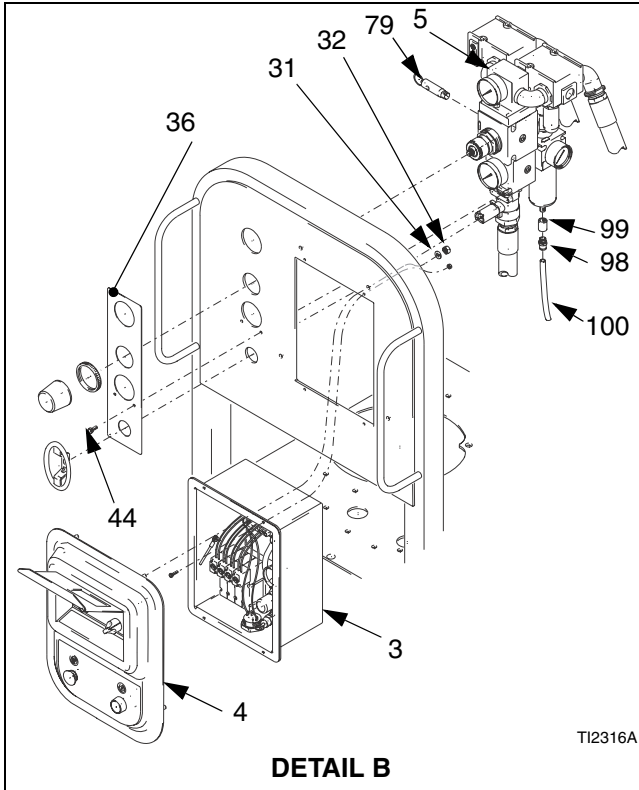

Pneumatic Control 245803

Item 3, page 33

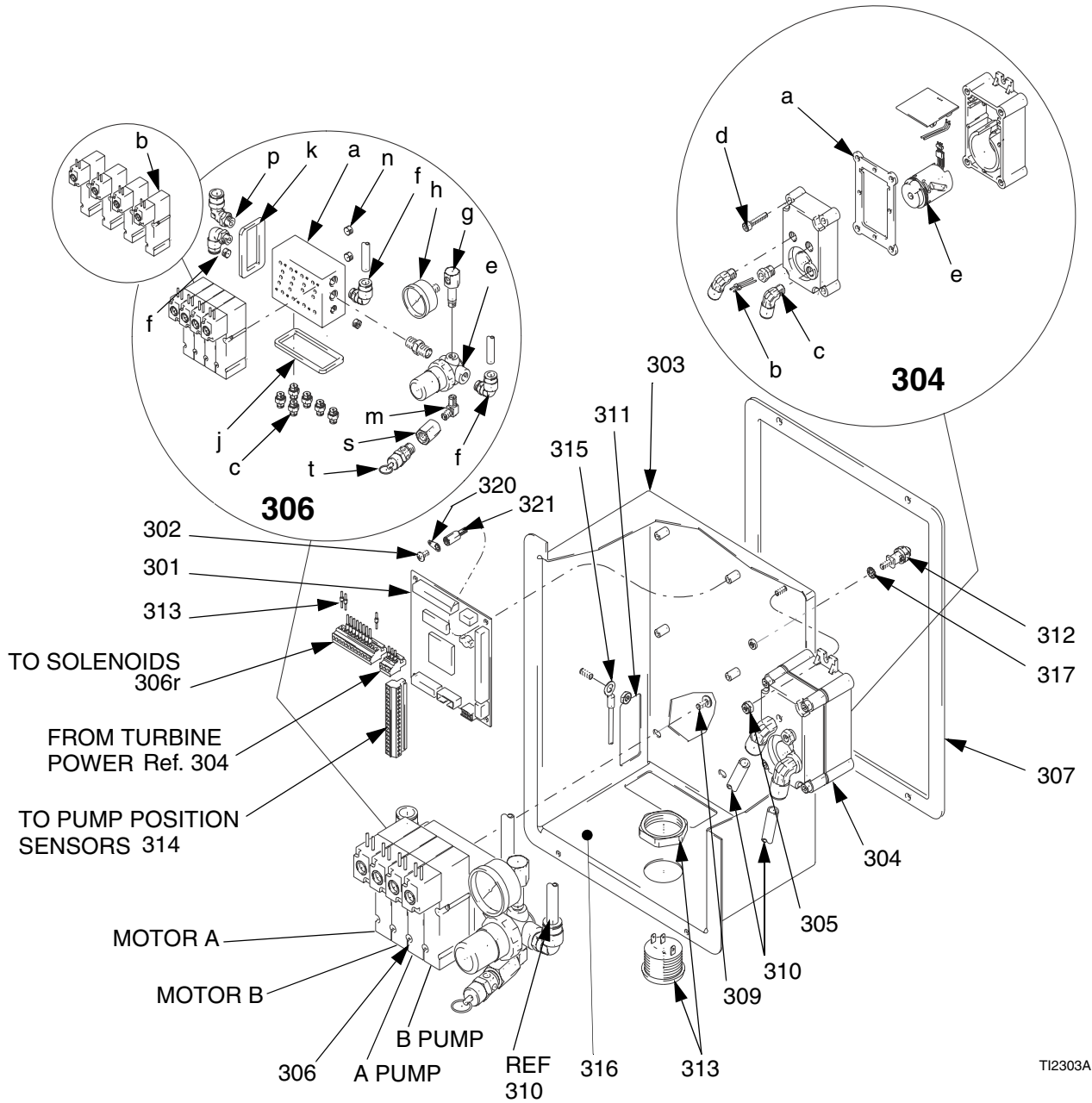

Pneumatic Control 245803

Ref. No.	Part No.	Description	Qty.	Ref. No.	Part No.	Description	Qty.
301	245705	CIRCUIT BOARD	1	315	15B090	GROUNDING WIRE, door	1
301a	15C318	FUSE, circuit board	1	316	15B056	LABEL, air connections	1
302‡		SCREW; 8-32 UNC	4	317	111307	LOCKWASHER	1
303‡		COVER	1	320	118132	LOCKWASHER, terminal	1
304**	245854	ALTERNATOR MODULE; includes items 304a-304e	1	321	118129	SPACER, 8-32 UNC x 5 in. (127 mm)	1
304a	193154	• GASKET	1	<i>IS = intrinsically safe</i>			
304b	15A853	• WIRE HARNESS	1	** Alternator bearing repair kit 223688 available.			
304c	111225	• TUBE FITTING; 90°	2	‡ Not available for order from Graco.			
304d	114380	• SCREW; M5 x 25	4	★ Order length needed from distributor.			
304e	249254	• TURBINE ALTERNATOR	1				
305‡		LOCKNUT; 8-32 UNC	2				
306‡		SOLENOID MODULE, IS; includes items 306a-306t	1				
306a	15A822	• MANIFOLD	1				
306b	117356	• VALVE, 12 VDC, IS	4				
306c	114263	• FITTING; 1/8 npt x 5/32 in. (4 mm) tube	6				
306d‡		• NIPPLE; 1/4 npt	1				
306e	115243	• AIR REGULATOR; 1/4 npt	1				
306f	115841	• ELBOW, swivel; 1/4 npt x 3/8 in. (9.5 mm) tube	3				
306g	160701	• ELBOW, street; 1/8 npt(m x f)	1				
306h	108190	• GAUGE,	1				
306j‡		• GASKET, neoprene	1				
306k‡		• GASKET, neoprene	1				
306n‡		• PLUG, pipe; 1/8-27 ptf	5				
306p	114128	• ELBOW; 1/4 npt x 1/2 in. (13 mm) tube	1				
306q‡	112512	• WIRE FERRULE, orange (not shown)	8				
306r	117369	• CONNECTOR, 12 position	1				
306s	150278	• ADAPTER, 1/4 x 1/8 npt	1				
306t	117480	• SAFETY RELIEF VALVE, 26 psi (179 kPa, 1.8 bar)	1				
307	15A800	GASKET, neoprene	1				
309‡		SCREW; M5 x 10	2				
310	C12508	TUBE, poly-flo; 3/8 in. OD; 1 ft. (3 m)	★				
311‡		NUT, KEPS; #10-24	1				
312	104029	GROUNDING STUD	1				
313	15A849	WIRE HARNESS, alarm	1				
314	117442	CONNECTOR, 18 position	1				

User Interface 245804

Item 4, page 33

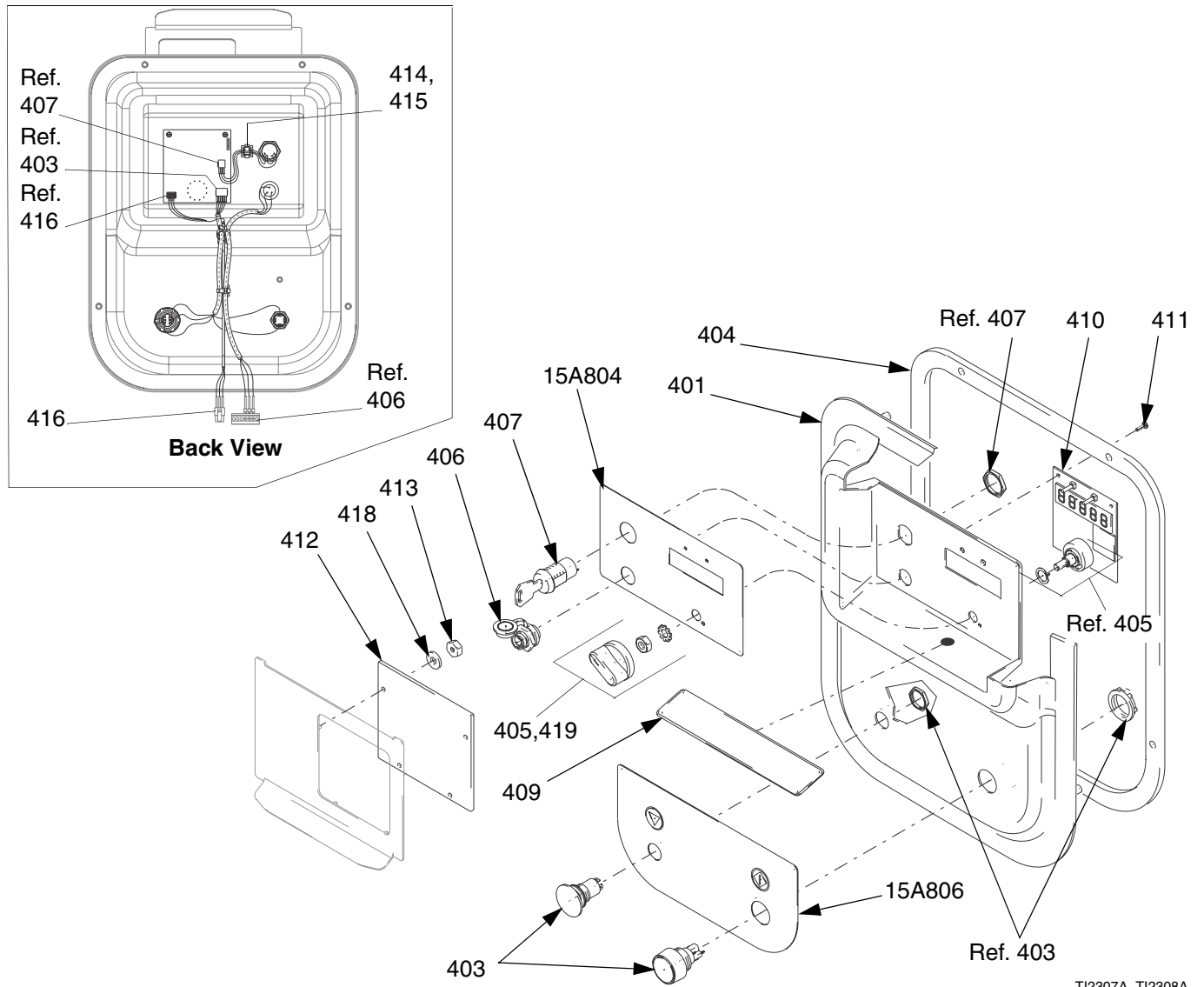

T12307A, T12308A

Ref. No.	Part No.	Description	Qty.
401‡		COVER	1
403	15A851	WIRE HARNESS, start/stop	1
404	15A801	GASKET	1
405	15C335	KNOB	1
406	15A850	WIRE HARNESS, data port	1
407	15A852	WIRE HARNESS, key switch	1
409*		LABEL, alarm code	1
410	245706	CIRCUIT BOARD	1
411‡		SCREW; 4-40	2
412	15A856	DISPLAY PANEL	1
413‡	514619	NUT; 4-40	4

Ref. No.	Part No.	Description	Qty.
414‡		MOUNT	3
415‡	102478	STRAP	3
416	15A854	WIRE HARNESS, display	1
418‡		WASHER	4
419	107232	SET SCREW	1

‡ Not available for order from Graco.

*** Alarm Code Labels**

Item 409, English provided. To order other languages:

Part No.	Languages
15B843	Chinese, Finnish, Portuguese, Greek, Swedish, Italian
15B844	English, Spanish, French, German, Korean, Japanese

Pump Air Manifold 245802

Item 5, page 33

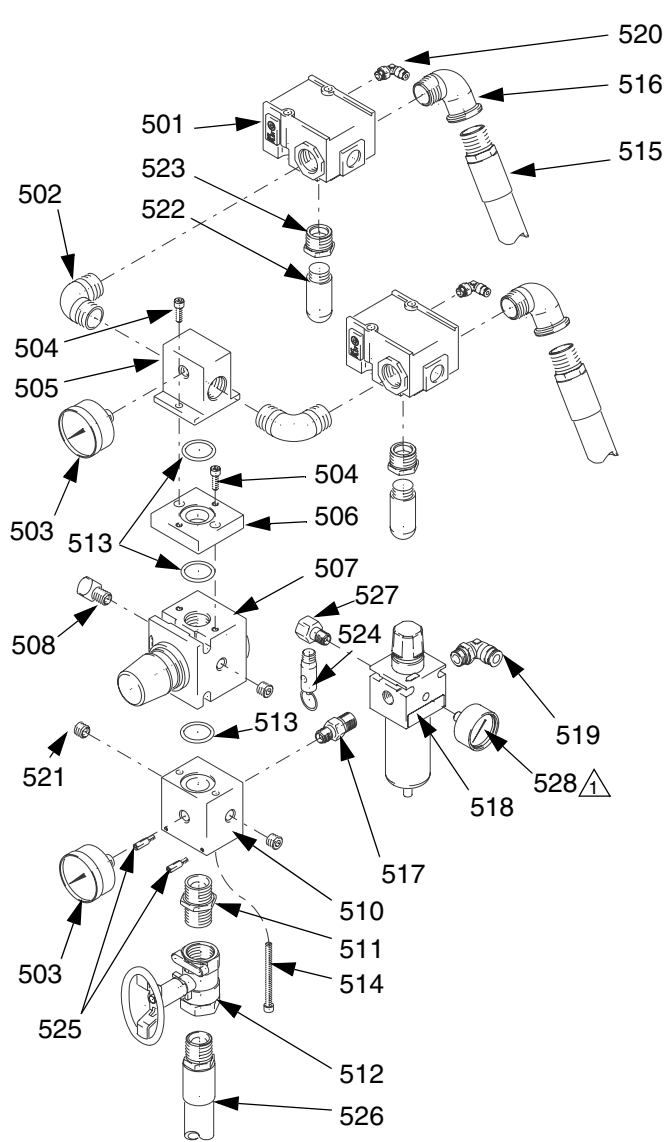

TI2295A

 100 psi (0.7 MPa, 7 bar) setting.

Ref. No.	Part No.	Description	Qty.
	507	117332 REGULATOR	1
	508	100840 ELBOW; 1/4 npt	1
	510	15A819 MANIFOLD BLOCK	1
	511	160032 NIPPLE; 3/4 npt	1
	512	117346 SHUTOFF VALVE, vented	1
	513	117364 O-RING, nitrite	3
	514	108849 SCREW; 1/4-20 UNC	2
	515	15B554 HOSE; 3/4 npt; 4 ft. (1.2 m)	2
	516	100549 ELBOW, 90°; 3/4 npt	2
	517	165198 NIPPLE; 1/4 x 3/8 npt	1
	518	119644 FILTER; 3/8 npt; 5 micron	1
	519	114316 ELBOW, swivel; 3/8 npt	1
	520	114151 ELBOW, swivel; 1/8 npt x 5/32 in. (4 mm) tube	3
	521	100721 PLUG; 1/4-18 nptf	2
	522	512912 MUFFLER; 1/2 npt	2
	523	100896 BUSHING; 3/4 x 1/2 npt	2
	524	113498 SAFETY RELIEF VALVE; 110 psi (0.8 MPa, 8 bar)	1
	525	117443 STANDOFF, aluminum, 8-32 UNC	2
	526	240900 HOSE; 3/4 npt; 2.5 ft. (0.76 m)	1
	527	158962 ELBOW, 1/8 (m) x 1/4 (f)	1
	528	113911 GAUGE, 1/8, air	1

Ref. No.	Part No.	Description	Qty.
501	C59752	VALVE, 3-way	2
502	108307	ELBOW; 3/4 npt	2
503	101689	PRESSURE GAUGE	2
504	112166	SCREW; 1/4-20 UNC	4
505	15A820	MANIFOLD	1
506	15A821	PLATE, direction	1

Metering Valve Manifold 245824

Item 6, page 34

Ref. No.	Part No.	Description	Qty.
601	245846	METERING VALVE; parts page 42	2
606	245861	SHUTOFF VALVE; see manual 306861	1
607a	245833	FLUID MANIFOLD; parts page 43	1
611	245860	SHUTOFF VALVE; see manual 306861	1

Metering Valve Manifold 248843

Item 6, page 34

Ref. No.	Part No.	Description	Qty.
601	245846	METERING VALVE; parts page 42	2
606	245861	SHUTOFF VALVE; see manual 306861	1
607b	249406	FLUID MANIFOLD, kit; see right	1
611	245860	SHUTOFF VALVE; see manual 306861	1

Sampling Valve 245143

Item 83, page 35

Ref. No.	Part No.	Description	Qty.
83a	245110	KNOB	1
83b	197681	HOUSING	1
83c	197332	SEAT	1
83d	107536	BALL, carbide	1
83e	110082	RETAINING RING	1
83f	111457	O-RING, PTFE	2
83g	183548	SEAT	1
83h	187060	GASKET	1

Repair Kit 249406

Ref. No.	Part No.	Description	Qty.
610	15E725	FLUID MANIFOLD	1
612	116343	GROUND SCREW	2
613	111307	LOCK WASHER	2
614	101754	PLUG, pipe	2
615	117502	REDUCER; #5 x #8 JIC	1
616	117556	NIPPLE; #8 JIC x 1/2 npt	1
617	117557	NIPPLE; #10 JIC x 1/2 npt	1
618	117677	REDUCER, #6 x #10 JIC	1

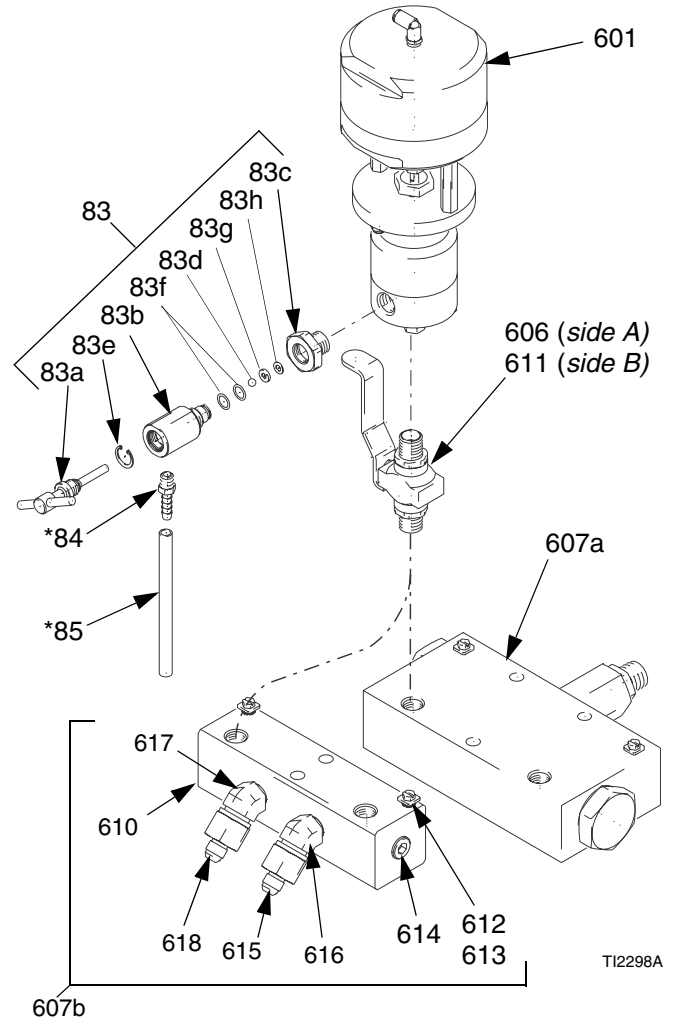

* See page 35 for part numbers and descriptions.

Metering Valve 245846

Item 601, page 41

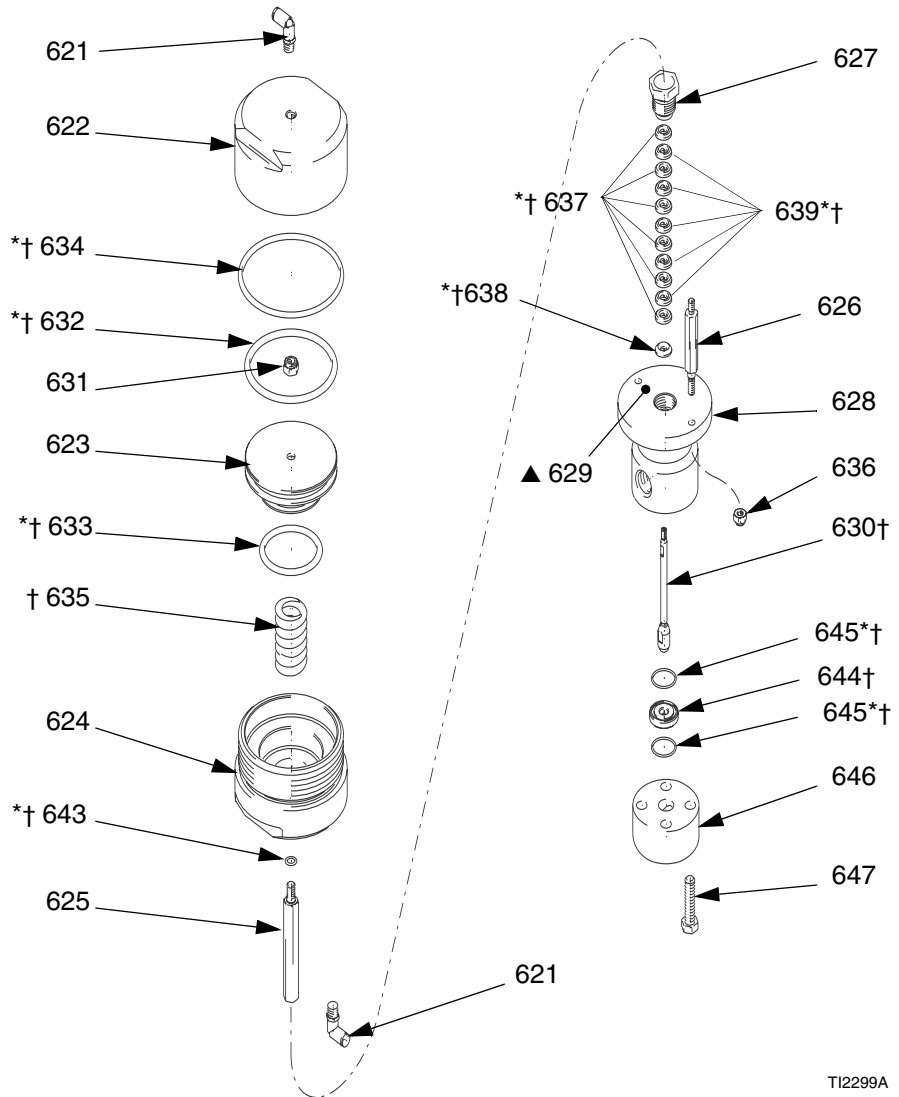

T12299A

Ref. No.	Part No.	Description	Qty.
621	598140	ELBOW, 1/8 npt(m) x 5/32 in. (4 mm) tube	2
622‡	15A840	VALVE CAP	1
623‡	15A841	PISTON	1
624‡	15A839	CYLINDER	1
625	15B545	PISTON ROD	1
626	15A834	TIE ROD	2
627	15A835	PACKING NUT	1
628	15A833	INLET HOUSING	1
629▲	180233	WARNING LABEL	1
630†	245850	FLUID NEEDLE	1
631	111040	LOCKNUT, nylon; 5/16 UNC-3B	1
632*†	117336	O-RING, nitrile	1
633*†	117370	O-RING, nitrile	1
634*†	117337	O-RING, nitrile	1
635†	109141	SPRING	1
636	102040	LOCKNUT; 1/4 UNC	2

Ref. No.	Part No.	Description	Qty.
637*†	117334	V-PACKING, UHMWPE	6
638*†	189901	GLAND, male	1
639*†	117335	V-PACKING, leather	5
643*†	111959	O-RING, buna-n	1
644†	15A830	SEAT	1
645*†	15T260	O-RING, fluoroelastomer	2
646	15A832	SEAT HOUSING	1
647	102637	SCREW; 3/8 UNC-2A	4

- * Parts included in kit 234098.
- † Parts included in kit 234131.
- ‡ Not available for order from Graco.
- ▲ Replacement Warning labels available at no cost.

Fluid Manifold 245833

Item 607a, page 41

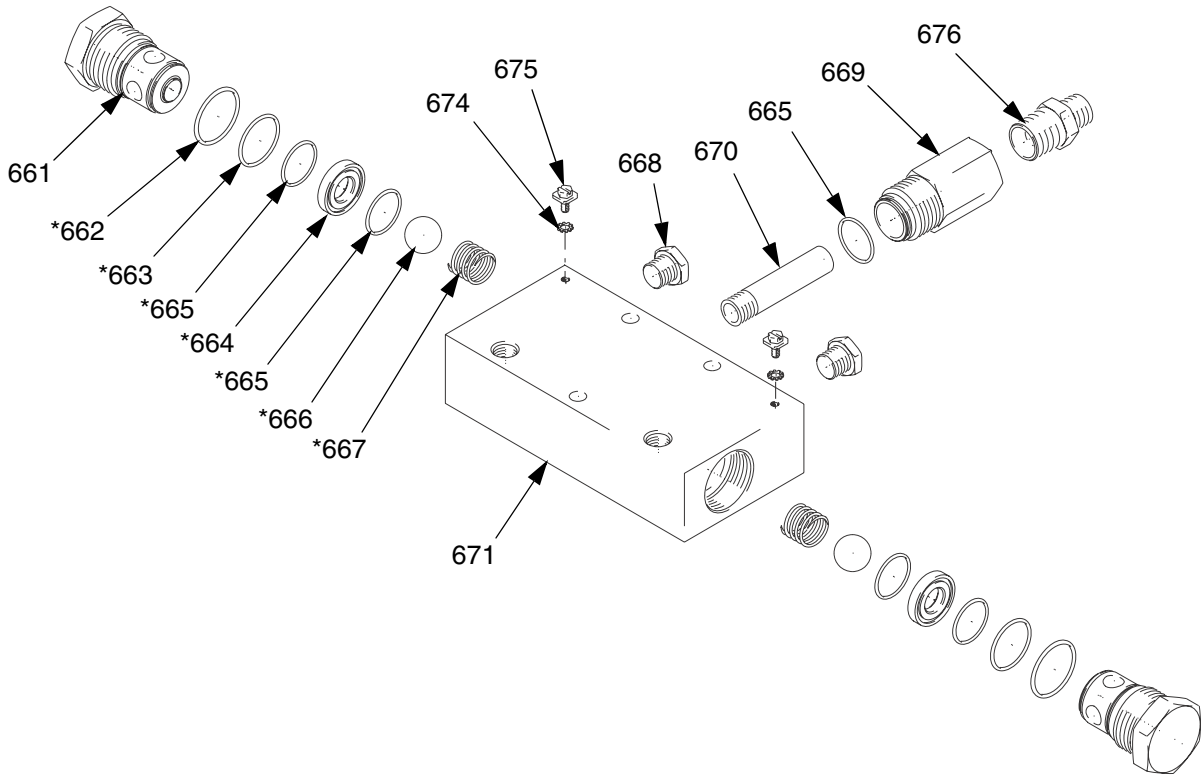

T12304A

Ref. No.	Part No.	Description	Qty.
661	15A823	PLUG	2
662*	107098	O-RING, PTFE	2
663*	107313	O-RING, PTFE	2
664*		SEAT	2
665*	103341	O-RING, PTFE	5
666*		BALL, metallic	2
667*	117333	SPRING	2
668		PLUG; 3/8 npt	4
669	15A825	PIPE, outlet	1
670	192977	PIPE, center	1
671‡		HOUSING	1
674	111307	LOCKWASHER	2
675	116343	GROUND SCREW,; M5 x 0.8	2
676	159239	NIPPLE; 3/8 x 1/2 npt	1

* Parts included in kit 234100.

‡ Not available for order from Graco.

Sensor 245825

Item 7, page 33

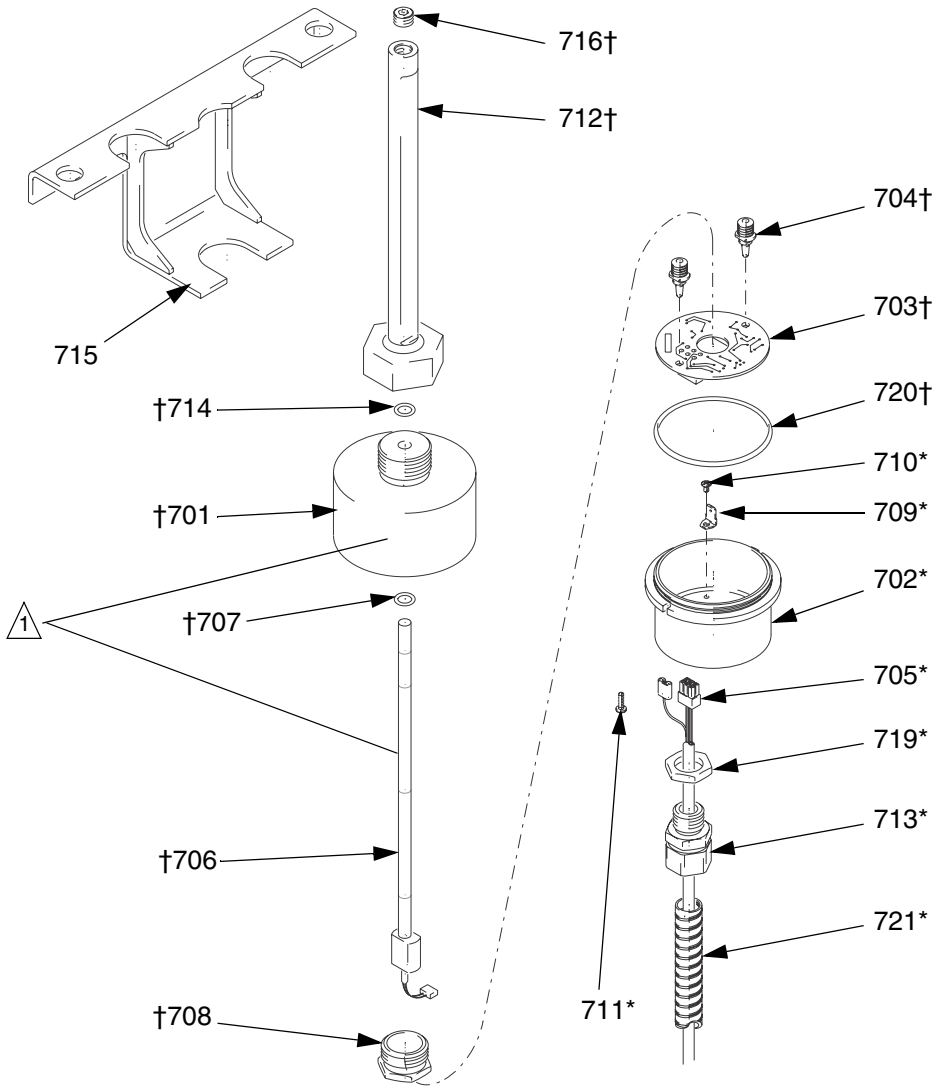

T12301A

Ref. No.	Part No.	Description	Qty.
701†	196280	CAP	1
702*	15A818	COVER	1
703†	243500	BOARD	1
704†	115925	SPACER	2
705*	117331	CABLE	1
706†	115917	SENSOR	1
707†	110004	O-RING, PTFE	1
708†	196289	CAP	1
709*	116024	TAB TERMINAL	1
710*	101855	SCREW; 4-24 UNC	1
711*	112546	SCREW; 4-40 taptite	2
712†	15A817	NUT; 1/8 npt	1

Ref. No.	Part No.	Description	Qty.
713*	117569	FITTING; 3/8 npt x 5/16 in. conduit	2
714†	154741	O-RING, buna-n	1
715	245831	BRACKET	1
716†	104765	PLUG; 18-27 ptf	1
719*	117586	LOCKNUT; 3/8-18 npt	2
720†	C20272	O-RING; fluoroelastomer	1
721*	117582	CONDUIT, 5 ft. (1.5 m); not shown	★

* Parts included in kit 246345.
 † Parts included in kit 246344.
 ★ Order length needed from distributor.

△ Calibration label.

Technical Data

Mix ratio range	0.0:1-10:1 (in 0.1 increments)
Ratio tolerance range	+/- 5%
Flow rates	
Minimum	1 qt./min. (0.95 liter/min.)*
Maximum	3 gal./min. (11.4 liter/min.)
Fluid viscosity range	200-20,000 cps (heavier viscosities can be mixed with use of optional heaters, heated hoses, and hardware)
Fluid filtration	60 mesh, (238 micron) standard on pump outlets (Filter assembly not included on models 248831, 248832, 248833, and 248834)
Air inlet	
Model 248842	3/4 npt(m)
All Other Models	3/4 npt(f)
Model 248842: Fluid inlet	3/4 npsm union in 1 in. npt(f) ball valve
Maximum fluid working pressure	
45:1	4500 psi (31 MPa, 310 bar)
56:1	5600 psi (38.6 MPa, 386 bar)
68:1	6800 psi (46.9 MPa, 469 bar)
68:1 Model 248842 only	5000 psi (34.5 MPa, 345 bar)
80:1	7250 psi (50 MPa, 500 bar)
Air supply pressure range	50-110 psi (345-800 kPa, 3.5-8 bar)
Model 248842: Maximum fluid feed pressure	500 psi (3.5 MPa, 35 bar)
Maximum air consumption at 100 psi (0.7 MPa, 7 bar) in cfm (m ³ /min.)	
45:1	110 (3.1)
56:1	125 (3.5)
68:1	155 (4.4)
80:1	180 (5.1)
Ambient temperature range	
Operating	32-130° F (0-54° C)
Storage	30-160° F (-1-71° C)
Environmental Conditions Rating	Indoor/outdoor use Altitude up to 4000 meters Maximum relative humidity to 99% up to 54° C Pollution degree (11) Installation category (2)
Sound pressure	98 dBA at 100 psi (0.7 MPa, 7 bar)
Wetted parts	
Suction tubes (if used)	aluminum
Pumps	carbon steel, alloy steel, 303, 440 & 17-4ph grades stainless steel, zinc and nickel plating, ductile iron, tungsten carbide, PTFE, leather
Metering Valves	carbon steel, zinc plating, carbide, polyethylene, leather
Manifold	carbon steel, zinc plating, carbide, 302 stainless steel
Mixer	stainless steel
Spray gun	See gun manual

Technical Data

PC Communications RS-232

Dimensions

Cart model (width x height x diameter) 33 in. wide x 64.53 in. high x 44.5 in. deep
(83.8 x 163.9 x 113 cm)
Weight (cart, without hose and gun) 625 lbs. (285 kg)

* *Minimum flow rate is dependent on the material being sprayed and mixing capability. Test your material for specific flow rate.*



A series of horizontal lines spanning the width of the page, providing a template for technical data or notes.

Graco Standard Warranty

Graco warrants all equipment referenced in this document which is manufactured by Graco and bearing its name to be free from defects in material and workmanship on the date of sale to the original purchaser for use. With the exception of any special, extended, or limited warranty published by Graco, Graco will, for a period of twelve months from the date of sale, repair or replace any part of the equipment determined by Graco to be defective. This warranty applies only when the equipment is installed, operated and maintained in accordance with Graco's written recommendations.

This warranty does not cover, and Graco shall not be liable for general wear and tear, or any malfunction, damage or wear caused by faulty installation, misapplication, abrasion, corrosion, inadequate or improper maintenance, negligence, accident, tampering, or substitution of non-Graco component parts. Nor shall Graco be liable for malfunction, damage or wear caused by the incompatibility of Graco equipment with structures, accessories, equipment or materials not supplied by Graco, or the improper design, manufacture, installation, operation or maintenance of structures, accessories, equipment or materials not supplied by Graco.

This warranty is conditioned upon the prepaid return of the equipment claimed to be defective to an authorized Graco distributor for verification of the claimed defect. If the claimed defect is verified, Graco will repair or replace free of charge any defective parts. The equipment will be returned to the original purchaser transportation prepaid. If inspection of the equipment does not disclose any defect in material or workmanship, repairs will be made at a reasonable charge, which charges may include the costs of parts, labor, and transportation.

THIS WARRANTY IS EXCLUSIVE, AND IS IN LIEU OF ANY OTHER WARRANTIES, EXPRESS OR IMPLIED, INCLUDING BUT NOT LIMITED TO WARRANTY OF MERCHANTABILITY OR WARRANTY OF FITNESS FOR A PARTICULAR PURPOSE.

Graco's sole obligation and buyer's sole remedy for any breach of warranty shall be as set forth above. The buyer agrees that no other remedy (including, but not limited to, incidental or consequential damages for lost profits, lost sales, injury to person or property, or any other incidental or consequential loss) shall be available. Any action for breach of warranty must be brought within two (2) years of the date of sale.

GRACO MAKES NO WARRANTY, AND DISCLAIMS ALL IMPLIED WARRANTIES OF MERCHANTABILITY AND FITNESS FOR A PARTICULAR PURPOSE, IN CONNECTION WITH ACCESSORIES, EQUIPMENT, MATERIALS OR COMPONENTS SOLD BUT NOT MANUFACTURED BY GRACO. These items sold, but not manufactured by Graco (such as electric motors, switches, hose, etc.), are subject to the warranty, if any, of their manufacturer. Graco will provide purchaser with reasonable assistance in making any claim for breach of these warranties.

In no event will Graco be liable for indirect, incidental, special or consequential damages resulting from Graco supplying equipment hereunder, or the furnishing, performance, or use of any products or other goods sold hereto, whether due to a breach of contract, breach of warranty, the negligence of Graco, or otherwise.

FOR GRACO CANADA CUSTOMERS

The Parties acknowledge that they have required that the present document, as well as all documents, notices and legal proceedings entered into, given or instituted pursuant hereto or relating directly or indirectly hereto, be drawn up in English. Les parties reconnaissent avoir convenu que la rédaction du présente document sera en Anglais, ainsi que tous documents, avis et procédures judiciaires exécutés, donnés ou intentés, à la suite de ou en rapport, directement ou indirectement, avec les procédures concernées.

Graco Information

For the latest information about Graco products, visit www.graco.com.

TO PLACE AN ORDER, contact your Graco distributor or call to identify the nearest distributor.

Phone: 612-623-6921 **or Toll Free:** 1-800-328-0211, **Fax:** 612-378-3505

All written and visual data contained in this document reflects the latest product information available at the time of publication. Graco reserves the right to make changes at any time without notice.

Original instructions. This manual contains English. MM 309518

Graco Headquarters: Minneapolis

International Offices: Belgium, China, Japan, Korea

GRACO INC. P.O. BOX 1441 MINNEAPOLIS, MN 55440-1441

Copyright 2002, Graco Inc. is registered to ISO 9001

www.graco.com

Revised 01/2011

Download from Www.Softmanuals.com. All Manuals Search And Download.

Free Manuals Download Website

<http://myh66.com>

<http://usermanuals.us>

<http://www.somanuals.com>

<http://www.4manuals.cc>

<http://www.manual-lib.com>

<http://www.404manual.com>

<http://www.luxmanual.com>

<http://aubethermostatmanual.com>

Golf course search by state

<http://golfingnear.com>

Email search by domain

<http://emailbydomain.com>

Auto manuals search

<http://auto.somanuals.com>

TV manuals search

<http://tv.somanuals.com>