

Maintaining and Troubleshooting the Gateway ALR 7300 Server

Part # 8504075

A MAN SYS US 7300 TECH REF R1

12/98

Notices

**Copyright © 1998 Gateway 2000, Inc.
All Rights Reserved
610 Gateway Drive
N. Sioux City, SD 57049 USA**

All Rights Reserved

This publication is protected by copyright and all rights are reserved. No part of it may be reproduced or transmitted by any means or in any form, without prior consent in writing from Gateway 2000.

The information in this manual has been carefully checked and is believed to be accurate. However, changes are made periodically. These changes are incorporated in newer publication editions. Gateway 2000 may improve and/or change products described in this publication at any time. Due to continuing system improvements, Gateway 2000 is not responsible for inaccurate information which may appear in this manual. For the latest product updates, consult the Gateway 2000 web site at www.gateway.com. In no event will Gateway 2000 be liable for direct, indirect, special, exemplary, incidental, or consequential damages resulting from any defect or omission in this manual, even if advised of the possibility of such damages.

In the interest of continued product development, Gateway 2000 reserves the right to make improvements in this manual and the products it describes at any time, without notices or obligation.

Trademark Acknowledgments

AnyKey, black-and-white spot design, CrystalScan, Destination, EZ Pad, EZ Point, Field Mouse, Solo, TelePath, Vivitron, stylized "G" design, and "You've got a friend in the business" slogan are registered trademarks and GATEWAY, Gateway Solo, green stylized GATEWAY, green stylized Gateway logo, and the black-and-white spotted box logo are trademarks of Gateway 2000, Inc. Intel, Intel Inside logo, and Pentium are registered trademarks and MMX is a trademark of Intel Corporation. Microsoft, MS, MS-DOS, and Windows are trademarks or registered trademarks of Microsoft Corporation. All other product names mentioned herein are used for identification purposes only, and may be the trademarks or registered trademarks of their respective companies.

**Copyright © 1998 Advanced Logic Research, Inc. (ALR)
All Rights Reserved
9401 Jeronimo
Irvine, CA 92618 USA**

All Rights Reserved

This publication is protected by copyright and all rights are reserved. No part of it may be reproduced or transmitted by any means or in any form, without prior consent in writing from ALR.

The information in this manual has been carefully checked and is believed to be accurate. However, changes are made periodically. These changes are incorporated in newer publication editions. ALR may improve and/or change products described in this publication at any time. Due to continuing system improvements, ALR is not responsible for inaccurate information which may appear in this manual. For the latest product updates, consult the ALR web site at www.alr.com. In no event will ALR be liable for direct, indirect, special, exemplary, incidental, or consequential damages resulting from any defect or omission in this manual, even if advised of the possibility of such damages.

In the interest of continued product development, ALR reserves the right to make improvements in this manual and the products it describes at any time, without notices or obligation.

Trademark Acknowledgments

ALR is a registered trademark of Advanced Logic Research, Inc. All other product names mentioned herein are used for identification purposes only, and may be the trademarks or registered trademarks of their respective companies.

Contents

Preface	V
Conventions used in this guide	vi
Safety instructions	vii
Additional information sources	viii
The Gateway Support Center.....	viii
System Access	1
Static electricity precautions	2
Opening the system	3
Removing the side panel.....	3
Removing the bezel.....	5
Removing the top cover	6
Closing the system.....	8
Replacing the top cover.....	8
Replacing the bezel	9
Replacing the side panel.....	10
Components	11
System board components	12
Chassis fans	14
Power connectors	14
Drive controllers and connectors.....	15
Front panel connectors.....	16
Server management connectors.....	18
System jumpers	19
I2O feature connector.....	19
Battery.....	19
Expansion slots.....	20
I/O connectors	20
Processor subsystem	21
Memory	22
Quick Hot-swap RAID cage.....	22
SCSI backplane components	23
Installing Components	25
Replacing the processor	26

Installing a second processor.....	30
Setting the jumpers.....	33
Processor speed jumper	33
Clear CMOS jumper.....	34
Installing memory and hardware.....	35
Installing memory	35
Adding and replacing drives.....	37
SCSI cable kit installation	51
Adding an expansion card	52
Removing an expansion card	54
Replacing the battery	56
Installing software and drivers	58
Installing the video drivers	58
NetWare 4.11 drivers and Seagate Backup Exec issues	59
BIOS Setup	61
About the BIOS Setup Utility.....	62
Using the BIOS Setup Utility	62
Main menu screen.....	63
Advanced menu screen.....	67
Security menu screen.....	76
Boot menu screen.....	78
Exit menu screen.....	80
Updating the BIOS.....	81
Troubleshooting	83
Introduction	84
Computer virus notice.....	84
Troubleshooting checklist	85
Verifying your configuration.....	86
Troubleshooting guidelines	86
CD-ROM problems	87
Hard disk problems.....	88
Memory/Processor problems	89
Modem problems	90
Peripheral/Adapter problems.....	91
Printer problems.....	93
System problems.....	94
Video problems.....	95

Error messages.....	98
Reference Data	101
Acronyms and abbreviations	102
Terms and definitions	106
Specifications.....	109
Memory map	110
I/O map	111
IRQ usage	112
DMA usage.....	113
DIMM configurations	114
Regulatory compliance statements.....	116
FCC Notice.....	116
Industry Canada Notice.....	116
CE Notice	117
VCCI Notice.....	117
Australia/New Zealand Notice	118
Index	119







Preface

Conventions used in this guide	vi
Safety instructions	vii
Additional information sources.....	viii

Conventions used in this guide

Throughout this guide, you will see the following conventions:

Convention	Description
ENTER	Keyboard key names are printed in small capitals.
CTRL+ALT+DEL	A plus sign indicates that the keys must be pressed simultaneously.
Setup	Commands to be entered, options to select, and messages that appear on your monitor are printed in bold.
<i>User's Guide</i>	Names of publications and files are printed in italic.
 <i>Important!</i>	An important informs you of special circumstances.
 <i>Caution!</i>	A caution warns you of possible damage to equipment or loss of data.
 <i>Warning!</i>	A warning indicates the possibility of personal injury.

Safety instructions

Observe the following safety instructions when using your system:

- Follow all instructions marked on the system and in the documentation.
- When the computer is turned off, a small amount of electrical current still runs through the computer. Always unplug the computer from the electrical outlet before cleaning the system or opening the computer cover. (Follow the cleaning instructions in your user's guide.)
- Do not use this product near water or a heat source, such as a radiator or heat register.
- Do not spill anything on or into the system. The best way to avoid spills is to avoid eating and drinking near your system.
- Make sure you set up the system on a stable work surface.
- Openings in the computer cabinet are provided for ventilation. Do not block or cover these openings. Make sure you provide adequate space (at least 12 inches) around the system for ventilation when you set up your work area. Never insert objects of any kind into the computer ventilation slots.
- Use the voltage setting for your area. The voltage selector switch is set at the factory to the correct voltage.
- As a safety feature, this system is equipped with a 3-wire power cord to ensure that the product is properly grounded when in use. The plug will only fit into a grounding-type outlet. If you are unable to insert the plug into an outlet, contact an electrician to install the appropriate outlet.
- Do not walk on the power cord or allow anything to rest on it.
- If you use an extension cord with this system, make sure the total ampere ratings on the products plugged into the extension cord do not exceed the extension cord ampere rating. Also, the total ampere requirements for all products plugged into the wall outlet must not exceed 15 amperes.

 **Warning!**

Do not attempt to service the system yourself except as explained elsewhere in the system documentation. Adjust only those controls covered in the instructions.

Opening or removing covers marked "Do Not Remove" may expose you to dangerous electrical voltages or other risks.

Refer all servicing of those compartments to qualified service personnel.

- There is a danger of explosion if the CMOS (complementary metal-oxide semiconductor) battery is replaced incorrectly. Replace the battery with the same or equivalent type recommended by the manufacturer. Dispose of used batteries according to the manufacturer's instructions.
- Unplug the system from the wall outlet and refer servicing to qualified personnel if:
 - The power cord or plug is damaged.
 - Liquid has been spilled into the system.
 - The system does not operate properly when the operating instructions are followed.
 - The system was dropped or the cabinet is damaged.
 - The system's performance changes.

Additional information sources

Along with this manual and your user's guide, you can find additional information by using the following sources.

The Gateway Support Center

Log on to the Gateway Support Center at www.gateway.com/support to access information about your system or other Gateway products. Some types of information you can access are:

- Hardware driver (including BIOS) and software application updates
- An expanded glossary
- Technical tips
- Service Agreement information
- Technical documents and component information
- Frequently Asked Questions (FAQ)
- Online access to Tech Support



System Access

Static electricity precautions	2
Opening the system	3
Closing the system.....	8

Caution!

Prevent electrostatic damage to your system by following static electricity precautions every time you open your computer case.

Warning!

To avoid exposure to dangerous electrical voltages and moving parts, turn off your computer and unplug the power cord before removing the system cover.

Static electricity precautions

Static electricity can permanently damage electronic components in your computer. When opening your computer case, always perform the following procedure:

1. Wear a grounding wrist strap (available at most electronics stores).
2. Turn off the system power.
3. Touch the back of the power supply fan, located on the back of the case, to discharge any static electricity.
4. Unplug all power cords from AC outlets.
5. Remove the computer case cover.

Follow these precautions to avoid electrostatic damage to your system components:

- Avoid static-causing surfaces such as plastic and styrofoam in your work area.
- Remove the parts from their antistatic bags only when you are ready to use them. Do not lay parts on the outside of antistatic bags since only the inside of the bag provides antistatic protection.
- Always hold cards by their edges and their metal mounting bracket. Avoid touching components on the cards and the edge connectors that connect to expansion slots.
- Never slide cards or other parts over any surface.

Opening the system

Depending on your purpose, you may need to remove only one or all of the system covers. Follow the instructions specific to the cover you wish to remove as indicated in each section.

Removing the side panel

Most of the system components are accessible through the side panel.

To Remove the Side Panel

1. Follow the ESD precautions described in “Static electricity precautions” on page 2.
2. Turn off the system and disconnect the power cord.
3. Remove the two screws that secure the side panel from the back panel of the system. See Figure 1.

▼ *Caution!*

Turn the system off and disconnect both power cords before proceeding. Installing any component while the power is on may cause permanent damage to the system.

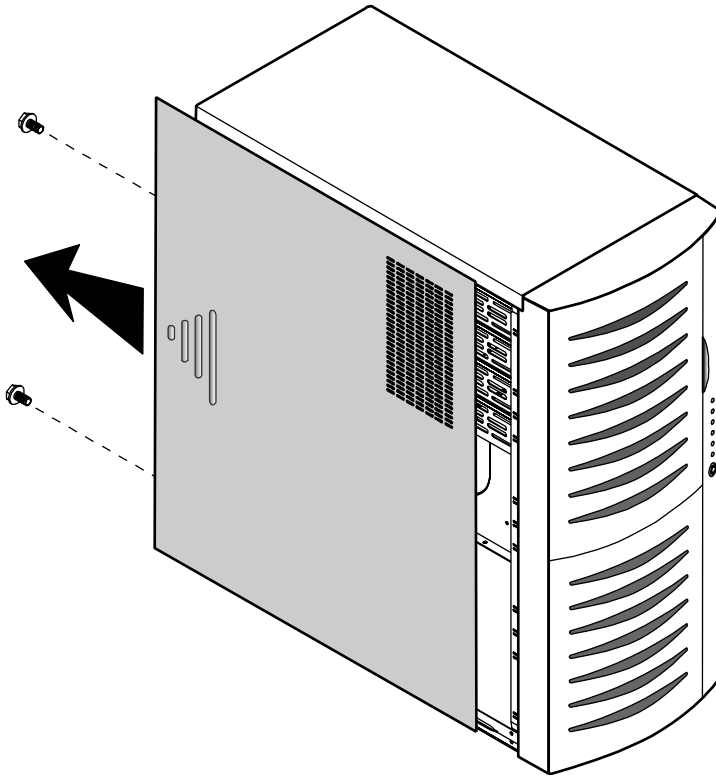

Figure 1: Removing the Side Panel

- 4.** Pull the cover toward the back of the system and remove it from the chassis.
- 5.** Set the side cover aside.
- 6.** If you need to remove the other side panel, repeat steps 3-5 for the other side of the system.

Removing the bezel

If you need to install or replace a 5.25-inch device or the 3.5-inch diskette drive, you need to remove the front bezel.

To Remove the Front Bezel

1. Follow the ESD precautions described in “Static electricity precautions” on page 2.
2. Turn off the system and disconnect the power cord.
3. Remove both side panels as described in “Removing the side panel” on page 3.
4. From the inside of the chassis, remove the two screws securing the bezel to the chassis. See Figure 2.

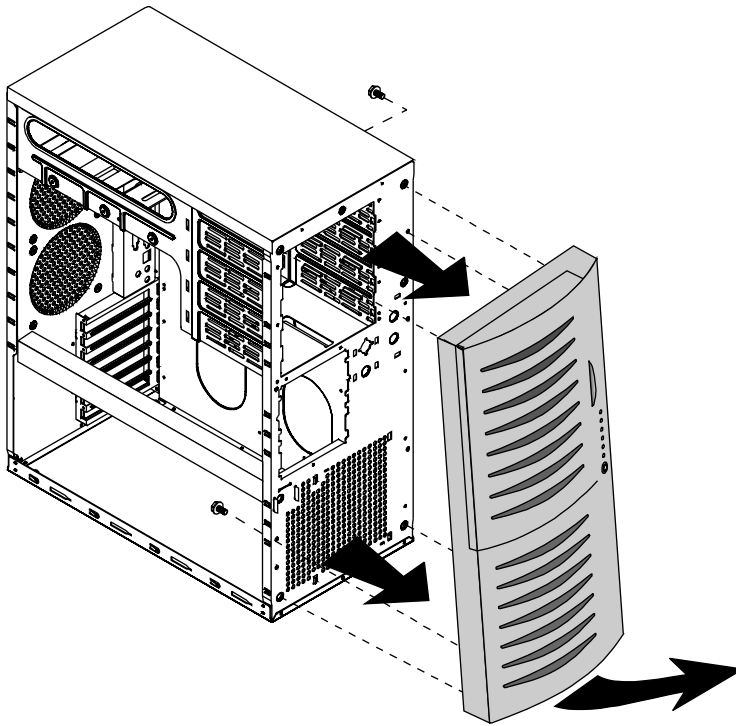

Figure 2: Removing the Bezel

5. Holding onto the bottom handle, firmly pull the bezel away from the chassis.
6. Set the bezel aside.

Removing the top cover

It may be easier to access the cables to the 3.5-inch diskette drive or any 5.25-inch devices by removing the top cover of the chassis.

To Remove the Top Cover

1. Follow the ESD precautions described in “Static electricity precautions” on page 2.
2. Turn off the system and disconnect the power cord.
3. Remove side panel as described in “Removing the side panel” on page 3.
4. Remove the front bezel as described in “Removing the bezel” on page 5.
5. Remove the four screws that secure the top panel to the chassis. Two are located at the rear of the system and two are located at the front of the system. See Figure 3.

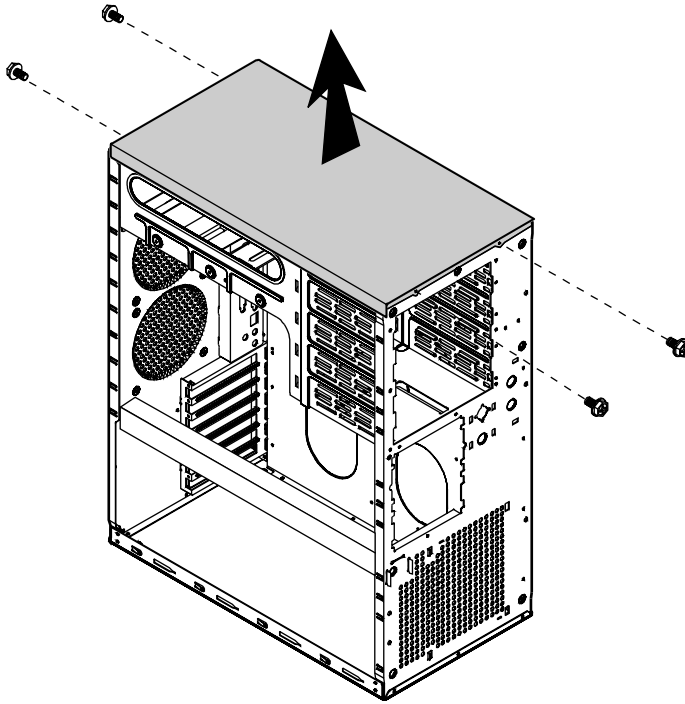

Figure 3: Removing the Top Cover

6. Pull the top cover straight up.
7. Set the cover aside.

Closing the system

Before closing the system, verify that all connectors and boards are properly installed and firmly seated.

Replacing the top cover

If you have removed the top cover to access components at the top of the system, replace the top cover before replacing other covering pieces.

To Replace the Top Cover

1. Align the top cover with the ledges on the chassis. See Figure 4.

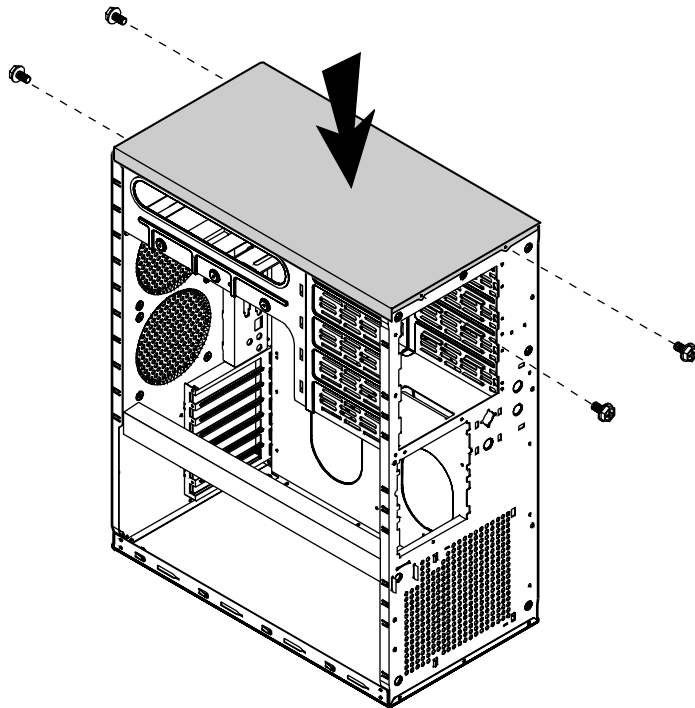

Figure 4: Replacing the Top Cover

2. Place the cover straight down on the top of the chassis.
3. Secure the cover with the four screws you removed earlier.

Replacing the bezel

After installing a 5.25-inch device or replacing the 3.5-inch diskette drive, replace the front bezel before you replace the side panel.

To Replace the Front Bezel

1. Position the bezel to the front of the chassis so that the bezel pegs are aligned with the mount holes on the front of the chassis. See Figure 5.

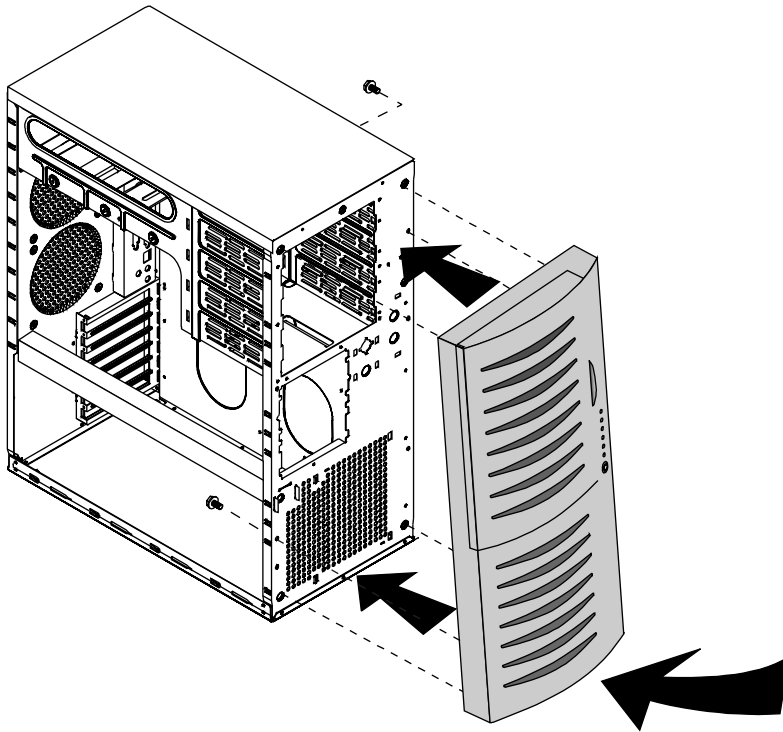

Figure 5: Replacing the Front Bezel

2. Insert the bezel pegs into the correct holes at the top of the chassis.
3. Swing the bottom of the bezel forward and press the pegs into the correct holes, securing the bezel to the chassis.
4. Secure the bezel with the two screws you removed when removing the bezel.

Replacing the side panel

The final step in closing the system is to replace the side panel.

To Replace the Side Panel

1. Align the side panel with the ledges on the chassis.
2. Slide the panel toward the front of the chassis (see Figure 6).

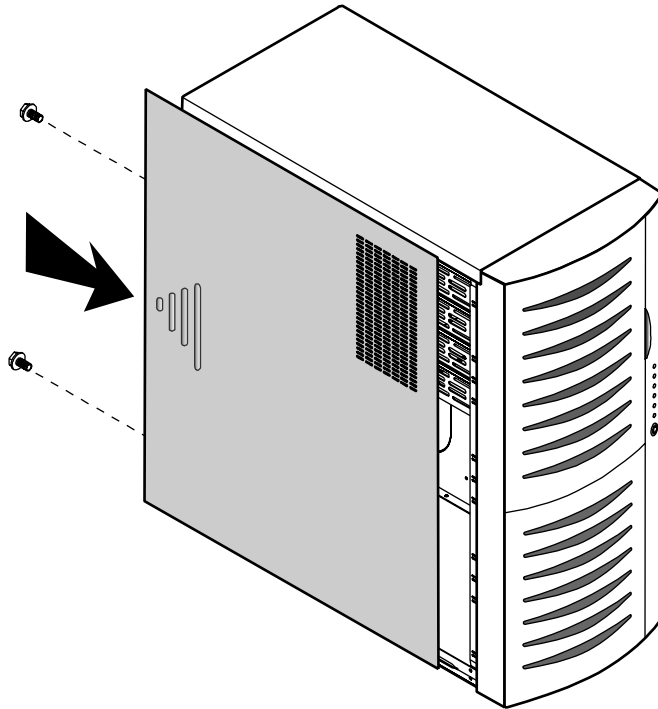

Figure 6: Reinstalling the Side Panel

3. Secure the panel with the screws you removed when opening the system.
4. If needed, repeat for the other side panel.



Components

System board components	12
Quick Hot-swap RAID cage	22
SCSI backplane components	23

J Diskette drive connector
K SHM Mode connector
L Front panel connector
M Reset connector
N External hard drive connector
O Hard drive LED connector
P Server management connector
Q I₂O feature connector
R User NMI connector
S EDC reset connector
T Chassis fan 3 connector
U Cover intrusion switch connector
V Speaker connector
W External boot ROM connector
X External I²C connector
Y SCSI B connector
Z SCSI A connector
AA Clear CMOS jumper
AB Battery
AC ISA slot 1 (shared with secondary PCI slot 4)
AD Secondary PCI slot 4 (shared with ISA slot 1)
AE Secondary PCI slot 3/RAIDport slot
AF Secondary PCI slot 2
AG Secondary PCI slot 1
AH Primary PCI slot 3
AI Primary PCI slot 2
AJ Primary PCI slot 1
AK Ethernet connector
AL Dual USB ports
AM Video port
AN Mouse and keyboard ports
AO Serial port 2
AP Parallel port
AQ Serial port 1

- AR** Slot 2 processor 1 connector (boot processor)
- AS** Slot 2 processor 2 connector (application processor)
- AT** DIMM bank A
- AU** DIMM bank B
- AV** DIMM bank C
- AW** DIMM bank D
- AX** Processor 2 fan connector
- AY** Processor 1 fan connector
- AZ** Embedded VRM for processor 1
- BA** VRM connector for processor 2
- BB** Processor speed setting jumpers
- BC** RAID cage connector
- BD** LED display/switch connector

Chassis fans

There are several chassis fan connectors on the system board. These connectors provide power for cooling fans that may be positioned in several parts of the chassis to cool critical components.

Power connectors

There are several power connectors that provide power for the system board. Some of these connectors provide power for specialized functions.

Primary power connector

The primary power connector provides the majority of the power to the system board. This connector is designed to accommodate the power supply installed in the system.

Supplemental power connector

The supplemental power connector provides additional power to the system board from the power supply.

Soft power connector

The soft power connector provides for the connection of a switch that powers up or powers down the server from a standby state. This connector is not used in the ALR 7300 server.

Power supply power fault connector

This connector allows you to connect a power supply fault detection LED to the system board to alert the user to a power supply fault. This connector is not used in the ALR 7300.

Auxiliary power supply connector

This connector allows additional connection to the system board to supply power. This connector is not used in the ALR 7300.

Drive controllers and connectors

There are several controllers and connectors for the control of the various drives that are or can be installed in the system.

Hard drive (IDE) controller and connectors

This is an integrated dual-channel Ultra-DMA PCI/IDE interface with two IDE connectors capable of controlling up to four IDE devices and supporting PIO Modes 0-4. Ultra-DMA provides faster access to IDE devices that are Ultra-DMA compliant while maintaining support for IDE devices that do not support the Ultra-DMA specification.

Diskette drive controller and connector

The diskette drive controller and connector on the system board can support up to two diskette drives of 360-KB, 720-KB, 1.2-MB, 1.44-MB, and 2.88-MB formats.

SCSI controller and connectors

This integrated dual channel Adaptec[®] AIC[™]-7890 SCSI controller is a high-performance, PnP compliant, single-chip PCI local bus-to-Ultra2 SCSI master host adapter. Its advanced SCSI I/O cell technology ensures data integrity for higher I/O bandwidth requirements with data rates of 40-MB/sec in Ultra mode and 80-MB/sec in Ultra2 mode.

Additional features:

- Dual LVD 16-bit (68-pin) PCI-to-Wide Ultra2 SCSI connectors
- Full 32-bit PCI bus master implementation maximizing data transfer on PCI local bus at 133-MB/sec data bursts
- SCSI configured automatically (SCAM) Level 1 for Windows 95[®] enabling automatic configuration of new devices without having to reboot the system.
- Wide SCSI configuration supporting up to 15 connected SCSI peripherals per channel, for a total of up to 30 devices. Up to seven 8-bit devices can be installed on each channel.
- Multithreading support for up to 255 simultaneous I/O tasks
- Advanced SCSI I/O cell ensuring data integrity by automatically and continuously adjusting slew rate to compensate for SCSI bus loading
- Driver support for all major operating systems.

Front panel connectors

There are several connectors that provide connection of the front panel features to the system board. Some of these connectors are redundant, allowing the front panel features to vary according to the system requirements and the chassis configuration. Therefore some of these connectors are not used in the system as shipped.

SHM mode jumper

This jumper identifies the physical environment for the InforManager server management software and should be removed from the ALR 7300.

Front panel connector

The front panel connector provides the signals for the front cover indicator LEDs and the front cover buttons. This connector is not used in the ALR 7300 server.

Reset connector

The reset connector provides the connection of the reset button from the front cover. This connector is not used in the ALR 7300 server.

External hard drive LED connector

The external hard drive LED connector allows you to connect a cable from an external hard drive to the system board to allow hard drive activity and system monitoring to recognize the external drive.

Hard drive LED connector

This connector allows you to connect all of the hard drives to the hard drive activity LED on the front cover. This connector is not used in the ALR 7300 server.

User NMI connector

This connector allows you to connect a signal cable which carries an user-induced NMI signal to the system board.

EDC reset connector

The EDC reset connector provides the connection for the keyboard lock button/ECC reset button from the front cover. This connector is not used in the ALR 7300 server.

Speaker connector

Connects the internal speaker to the system board.

External boot ROM connector

Provides connection for expansion cards that contain a separate boot ROM and require independent access to the system board.

LED Display/Switch connector

Connects the LEDs and switches on the front cover to the system board.

Server management connectors

The server management connectors provide hardware and component monitoring to assist you in maintaining the server.

Server management connector

The server management connector allows you to connect a server management device to the system board to monitor system activities.

Cover intrusion switch connector

Connects a cover intrusion switch to the system board so that the system can monitor unauthorized access to the chassis. This feature is not implemented in this system.

I²C connector

This connector is part of the system monitoring. It carries the signals of the I²C bus which include identifying information and status for major system components.

RAID cage connector

The RAID cage connector connects the SCSI backplane to the system board to allow status and monitoring of backplane and SCSI drive status.

System jumpers

The jumpers allow you to set certain characteristics of the system. Some jumpers are reserved and are not described in this section. Do not change any jumper unless it is necessary to configure the system. In some cases, changing the settings of reserved jumpers can cause damage to the system board.

Clear CMOS jumper

This jumper allows you to clear the CMOS memory. You should only do this if you cannot access the normal methods of modifying the CMOS and modifications to the CMOS are necessary. Clearing CMOS memory returns all BIOS Setup settings to the default values.

CPU speed setting jumper

This jumper allows you to set the speed of the processor. Both processors, in dual processor configurations, must have the same speed rating. If processors of different speeds are used in the same system, the processors must run at the speed of the slower processor.

I₂O feature connector

This connector is designed to accommodate an intelligent input/output (I₂O) compatible expansion card. At the time this manual was published, no fully I₂O compatible board was available for testing.

Battery

Provides the power to maintain the CMOS memory when the system is turned off or unplugged.

Expansion slots

The system features seven expansion slots: five PCI slots, one shared PCI/RAID port slot, and one shared PCI/ISA slot. The I₂O feature connector is aligned with one of the PCI slots (secondary PCI slot 1). If you install a card in the I₂O feature connector, you may not be able to use the corresponding PCI slot.

The PCI bus processes peripheral transactions at a system clock speed of up to 33 MHz.

I/O connectors

The I/O connectors are located on the back cover of the system. Figure 8 shows the connectors.

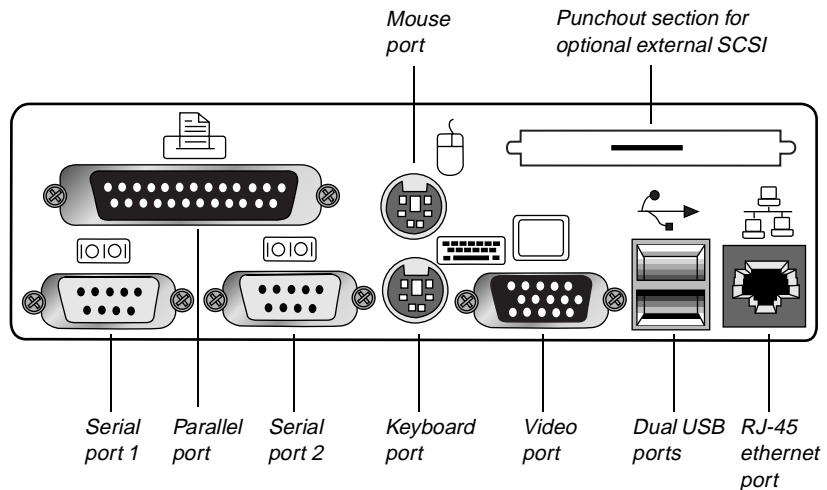

Figure 8: I/O Connectors

The following I/O connectors are included with the system:

- Two universal serial bus (USB) ports provide connection for a growing list of peripherals including mouse, keyboard, joystick, monitor, tape, and diskette drives. You can daisy-chain up to 127 devices from each port. The port also provides hot-swap capability

and dynamic resource allocation for all attached peripherals. Most major operating systems provide USB drivers and should require no special procedures for implementation or use.

- Two 9-pin 16550-compatible serial ports
- One bidirectional ECP/EPP parallel port
- One video port
- One PS/2-style mouse port
- One PS/2-style keyboard port
- One RJ-45 Ethernet connector with two LEDs. The green LED shows that the system is communicating with the network and the yellow LED shows that communication is occurring at 100 Mbps.

Processor subsystem

The system board supports as many as two processors (CPUs). The board provides several additional connectors for supporting components, as described in the following paragraphs.

Processors and processor slots

Depending on the model, the system is equipped with one Intel Pentium® II Xeon™ processor with 512-KB, 1-MB, or 2-MB ECC L2 cache, integrated into a single edge contact (SEC) cartridge.

The system SMP design supports up to two processors and is Intel MP Specification v1.1 and 1.4 compliant.

Processor fan connectors

The processor fan connectors provide power for the fans mounted on the processor heatsinks. These fans cool the processors and prevent overheating. Note that not all processor heatsinks have or need fans. If the processor heatsink includes a fan, connect it to the correct fan connector.

★ *Important!*

Processor slot 1 is the boot processor slot. In a single processor configuration, the processor must be installed in processor slot 1 and a terminator card must be installed in processor slot 2.

Voltage regulator modules

Each processor must have a dedicated voltage regulator module (VRM) which adjusts the voltage supplied to the processor. The VRM for the first processor (CPU 1) is embedded on the system board.

Memory

The system comes standard with 64-MB of ECC RAM. System RAM is expandable up to 2-GB using 100 MHz ECC 72-bit synchronous DRAM (SDRAM) DIMMs (4 DIMM sockets).

Quick Hot-swap RAID cage

The quick hot-swap cage allows you to configure a reliable RAID subsystem. The quick hot-swap cage consists of a drive cage and all of the necessary hardware to install it in the system. Each cage supports three one-inch high 3.5-inch SCA SCSI drives. For optimum operation, use only approved RAID-ready drives in the RAID Cage. The RAID Cage occupies two standard half-height 5.25-inch drive bays.

Drives are mounted on a rail system which provides quick and easy installation and hot-swapping. A fully functional RAID subsystem is controlled by a RAID caching controller.

Hot-swapping is a useful features that allows you to replace a failed hard disk drive without interrupting system operation. In the event of a hot-swappable drive failure, which is part of a RAID 5, the system

★ *Important!*

The quick hot-swap RAID Cage may or may not be included as a standard part of the server configuration.

continues normal operations. You can replace the failed drive and rebuild its contents on an equivalent replacement drive automatically, without shutting down the system.

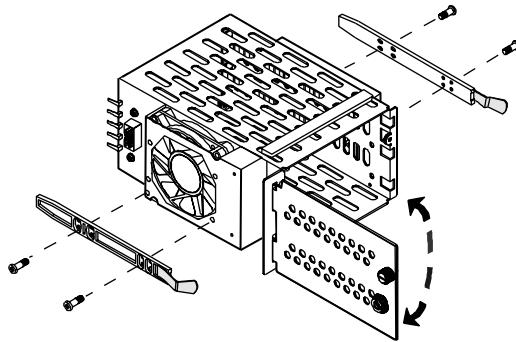

Figure 9: RAID Cage

SCSI backplane components

The SCSI backplane connects the SCA-2 LVD SCSI drives to the SCSI RAID controller or the SCSI controllers on the system board. The backplane provides automatic SCSI address setting and allows hot-swapping of SCSI drives. Figure 10 shows the back of the backplane where the drives connect.

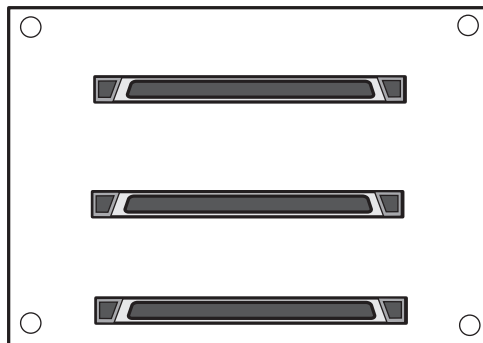

Figure 10: The Back of the SCSI Backplane

If the RAID cage is included as part of the server configuration, see the *Quick Hot-swap Installation Guide* for information on how to configure the quick hot-swap backplane.





Installing Components

Replacing the processor.....	26
Installing a second processor.....	30
Setting the jumpers	33
Installing memory and hardware	35
Installing software and drivers	58

Replacing the processor

The system is compatible with Intel Pentium® II Xeon™ processors.

You can either upgrade the existing Pentium II Xeon processor or install a second processor of the same speed as the first processor.

When replacing a processor, order a Pentium II Xeon processor upgrade kit. The kit includes the Pentium II Xeon processor, a heat sink, and a VRM.

It is critical that a heat sink be installed on each Pentium II Xeon processor. The Pentium II Xeon processor overheats and fails if it is not cooled sufficiently. The heat sink provided with the processor on the system provides all necessary cooling for the processor.

For the latest details on the availability of the upgrade kits, contact one of the sources listed in the *Assistance Resources* document.

★ Important!

If the error message “update table not found for CPUxx, Stepping xxxx” displays at boot up, run the MULoader utility located on the disk included with your processor kit. This message may occur under the following conditions: When a new processor has been added that does not include the stepping information in the table. When the BIOS is flashed, it may remove the stepping information from the table which will cause the error message to appear.

To Replace the Processor

1. Turn off the system and disconnect the power cord.
2. Open the case (“Opening the system” on page 3), observing the static electricity precautions in “Static electricity precautions” on page 2.
3. Wearing an anti-static wristband grounded to the system chassis, remove the lock bar from the processor slot by removing the two screws that secure it (see Figure 11).

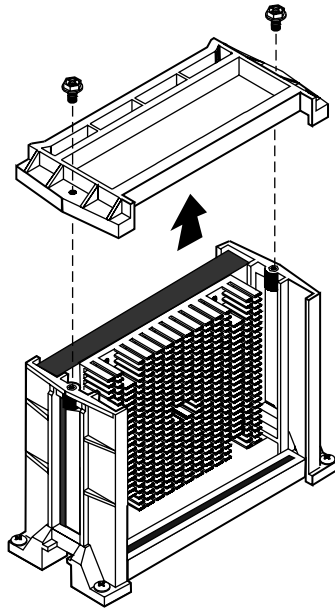

Figure 11: Removing the Lock Bar

4. Lift the cartridge up and away from the system board. See Figure 12.

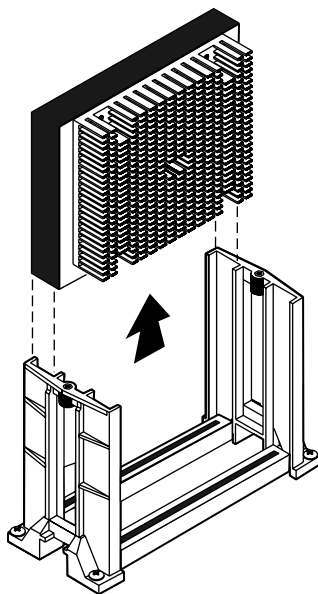

Figure 12: Removing the Processor

5. Place the processor cartridge that you removed in a safe place.
6. Remove the replacement processor cartridge from its protective wrapping and place it in the cartridge supports for the slot 2 connector.
7. Slide the cartridge all of the way down until it is firmly seated. See Figure 13.

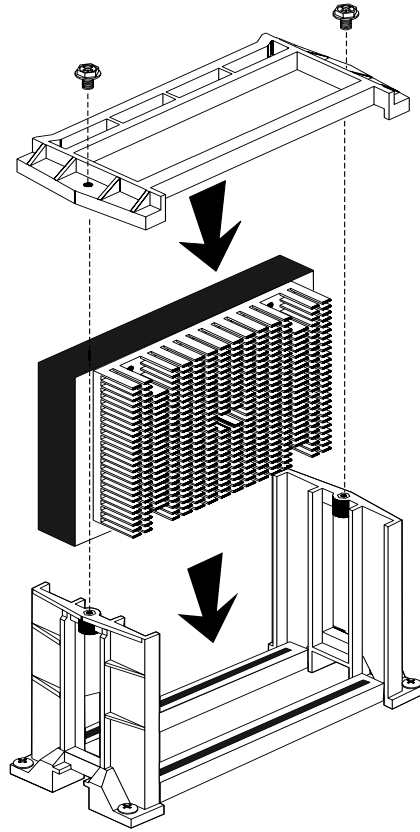

Figure 13: Installing the Replacement Processor

- 8.** If the processor cartridge does not already have the heatsink attached to it, attach the heatsink according to the instructions that came with the processor upgrade kit.
- 9.** Replace the lock bar on the processor support and secure it with the two screws that you removed in Step 3.
- 10.** Set the jumpers for the new processor configuration (see the section “Setting the jumpers” on page 33).
- 11.** Close the case, as described in “Closing the system” on page 8.
- 12.** Reconnect the power cord and turn on the system.

Installing a second processor

The system is compatible with Intel Pentium II Xeon processors.

You can either upgrade the existing Pentium II Xeon processor or install a second processor of the same speed as the original processor.

When adding a processor, order a Pentium II Xeon processor upgrade kit. The kit includes the processor, a heat sink, and aVRM.

It is critical that a heat sink be installed on each Pentium II Xeon processor. The processor overheats and fails if it is not cooled sufficiently. The heat sink provided with the processor on the system provides all necessary cooling for the processor.

For the latest details on the availability of the upgrade kits, contact one of the sources listed in the *Assistance Resources* document.

To Install a Second Processor

1. Turn off the system and disconnect the power cord.
2. Open the case (“Opening the system” on page 3), observing the static electricity precautions in “Static electricity precautions” on page 2.
3. Remove the lock bar from the processor supports as shown in Figure 11 on page 27.
4. Remove the Terminator Card from the system board (see Figure 14).

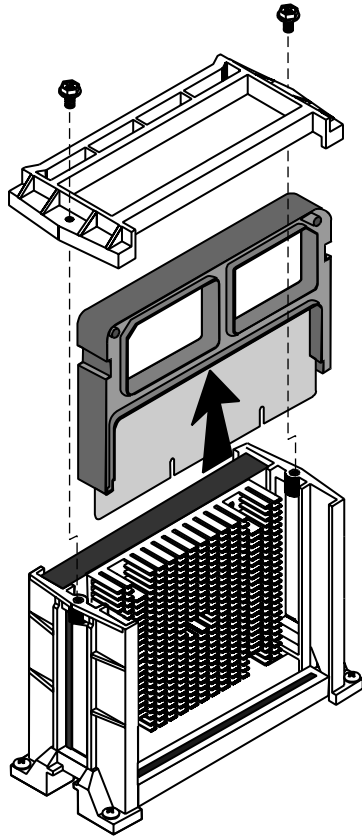

Figure 14: Removing the Terminator Card

5. Align the new Pentium II Xeon SEC cartridge into the CPU 2 connector and press it firmly into place. See Figure 15.

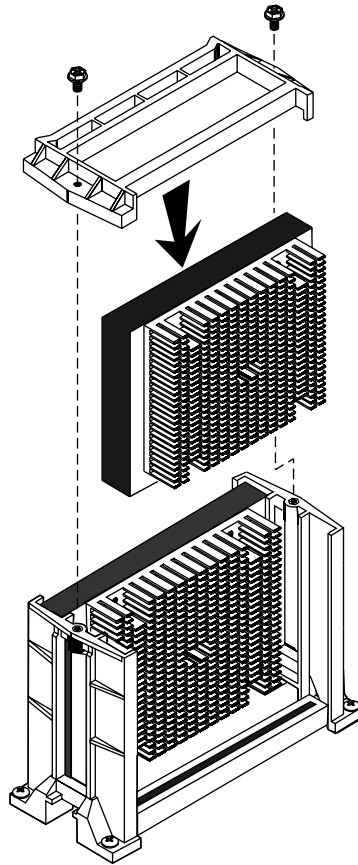

Figure 15: Installing the Second Processor

- 6.** Place the lock bar on top of the supports and secure it by inserting and tightening the two screws you removed in Step 3.
- 7.** Set the jumpers for the new processor configuration (see the section “Setting the jumpers” on page 33).
- 8.** Insert the VRM into the connector provided until the release clips click into place.
- 9.** Close the case, as described in “Closing the system” on page 8.
- 10.** Reconnect the power cord and turn on the system.

Setting the jumpers

















The system board jumpers let you change several system functions. Jumpers are set to the default positions at the factory. You may need to change the jumper settings to perform the following functions:

- Set processor/bus speed settings
- Clear CMOS memory

Processor speed jumper

The system board supports a range of processor speeds, which are set by changing jumpers. If you upgrade your processor, you may need to change jumper settings. The Processor Speed jumper (JP22) configuration block lets you set the processor speed.

The system automatically detects the bus speed supported by the processor and uses the jumper settings in conjunction with the detected bus speed to set the processor speed. If two processors are present and they support different speeds, the system operates at the slower speed. Move the jumper shunts on jumper block JP22 to connect the jumper pins according to the table below. Processor speeds are given in relation to bus speeds of 66MHz/100MHz.

Pentium II Xeon	CPU Speed Settings JP22
400 MHz	2     8 1     7
450 MHz	2     8 1     7

★ *Important!*

If the error message “update table not found for CPUxx, Stepping xxxx” displays at boot up, run the MULOADER utility located on the disk included with your processor kit. This message may occur under the following conditions: When a new processor has been added that does not include the stepping information in the table. When the BIOS is flashed, it may remove the stepping information from the table which will cause the error message to appear.

Clear CMOS jumper

The Clear CMOS jumper (JP15) lets you clear all current values in complimentary metal-oxide semiconductor (CMOS) memory (see “System Board Components” on page 14 for the location of the jumper). CMOS memory stores all of the BIOS Setup information and settings. Clearing the CMOS memory restores all setup values to the original system defaults.

A jumper shunt connecting pins 1 and 2 sets the jumper for normal operation. A jumper shunt connecting pins 2 and 3 sets the jumper to clear the CMOS memory at the next system boot.

To Clear CMOS Memory

1. Restart the server and press F2 to enter the BIOS Setup utility.
2. Write down the current BIOS configuration settings for later reference.
3. Turn off the system and disconnect the power cord.
4. Open the case (“Opening the system” on page 3), observing the static electricity precautions in “Static electricity precautions” on page 2.
5. Move the jumper shunt on the Clear CMOS jumper (JP15) to connect pins 2 and 3.
6. Reconnect the power cord and turn on the system. Wait until the system boots and you see the message that confirms the CMOS memory has been cleared.
7. Turn off the system again and disconnect the power cord.
8. Move the jumper shunt on the Clear CMOS jumper (JP15) back to its normal position connecting pins 1 and 2.
9. Close the case, as described in “Closing the system” on page 8.
10. Reconnect the power cord and turn on the system.

Clearing the CMOS memory clears all passwords and all configuration settings. You must reset any necessary values in BIOS Setup after you clear CMOS memory.

Installing memory and hardware

Installing memory

The system board supports up to 2 GB of RAM in ECC SDRAM DIMMs.

The system board is configured with 4 DIMM banks. You can fill Bank 0, Bank 1, Bank 2, or Bank 3 or a combination of banks with DIMMs. No jumper settings are required for the memory size or type because this information is automatically detected by the BIOS.

Refer to the section “DIMM configurations” on page 114 for valid memory configurations. You may select any combination that provides the total RAM required by your system and applications.

★ Important!

In order to reach 2 GB of RAM, you must install 512 MB DIMMs. At the time this manual was published, 512 MB DIMMs were not readily available. These DIMMs had not been tested with this system at this time. This manual assumes that the 512 MB DIMMs will conform to published standards and that no significant problems will be discovered in testing.

To Install DIMMs

1. Turn off the system and disconnect the power cord.
2. Open the case (“Closing the system” on page 8), observing the static electricity precautions in “Static electricity precautions” on page 2.
3. Pull open the socket clamps on each side of the DIMM socket (see Figure 16).

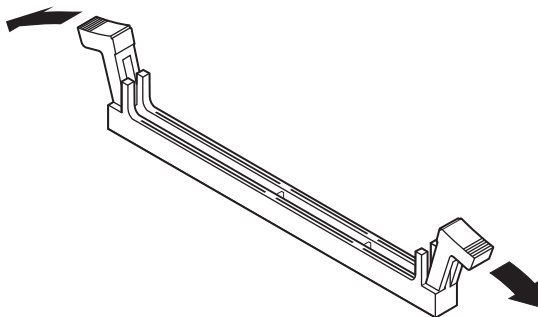

Figure 16: Opening the DIMM Socket Clamps

4. Align the two notches in the DIMM with the two notches in the DIMM socket (see Figure 17) and insert the DIMM into the socket.

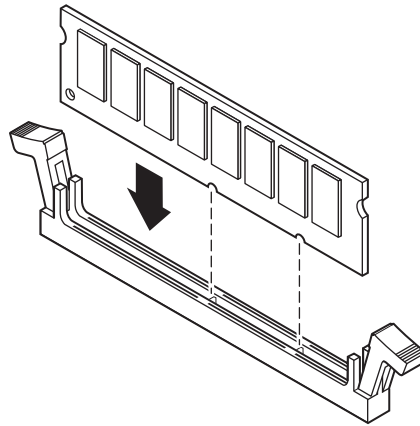

Figure 17: Inserting the DIMM

5. Gently press the DIMM into the socket until it is firmly seated. (Inserting the DIMM automatically locks the socket clamps on each end of the DIMM.)
6. Close the case, as described in “Closing the system” on page 8.
7. Reconnect the power cord and turn on the system.

To Remove DIMMs

1. Gently push out the plastic socket clamps on each end of the DIMM. The DIMM should pop up slightly from the socket (see Figure 18).

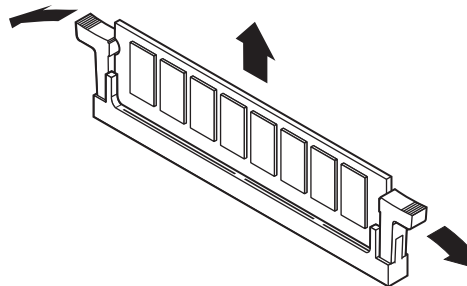

Figure 18: Releasing the DIMM Socket Clamps

▼ **Caution!**

Never try to remove a DIMM without releasing the clamps. You may break the socket, causing serious damage.

- Carefully lift the DIMM out of the socket (see Figure 19).

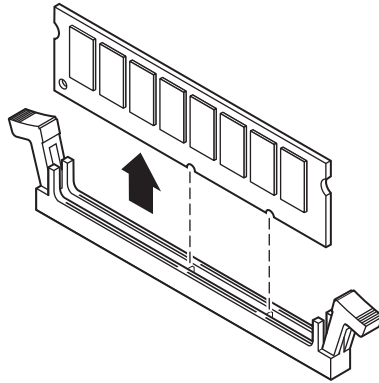

Figure 19: Removing the DIMM

- Store the DIMM in a static-free container.

Adding and replacing drives

The case must be opened to add or replace drives (such as disk drives and CD-ROM drives) in the system. Refer to “Opening the system” on page 3 for instructions on opening and closing the case.

Replacing a 3.5-inch drive in the front drive bay

The 3.5-inch drives are secured to a metal mounting bracket, which enables easy installation and removal from the system chassis. This bracket supports a 3.5-inch diskette drive which was installed at the factory. There is space in the bracket for a second front-accessible drive and up to two internally accessible one inch tall 3.5-inch drives.

To Replace the 3.5-inch Diskette Drive

- Turn off the system and disconnect the power cord.
- Open the case (“Opening the system” on page 3), observing the static electricity precautions in “Static electricity precautions” on page 2.

3. Locate the 3.5-inch drive bracket.
4. Disconnect the power and data cables from the back of the drive that you want to replace, noting their location and orientation. (You will reconnect these cables after you install the new drive.)
5. Remove the screws securing the drive bracket to the system chassis, and remove the drive bracket from the chassis. Doing so also removes the 3.5-inch metal filler panel from the front of the drive bracket (see Figure 20).

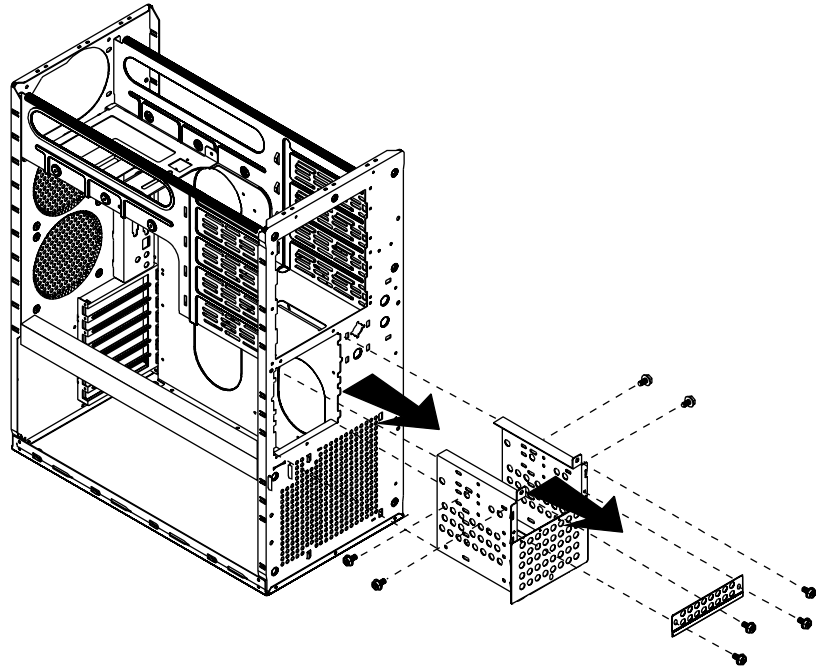

Figure 20: Removing the 3.5-inch Drive Bracket

6. Remove the screws securing the 3.5-inch drive to the bracket, and then remove the 3.5-inch drive (see Figure 21).

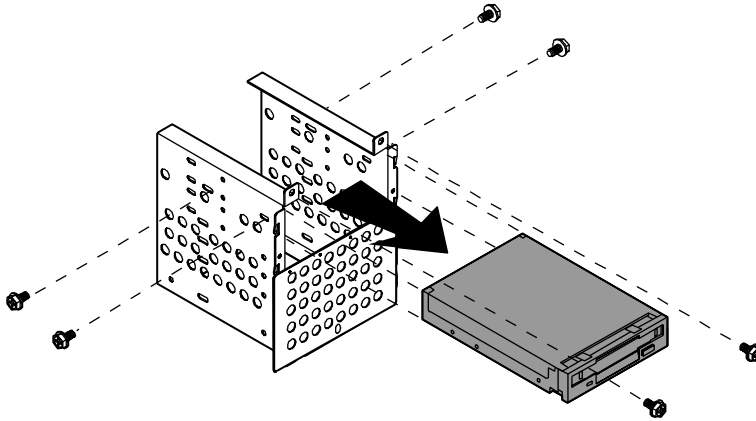

Figure 21: Removing the 3.5-inch Drive

7. Place the new 3.5-inch drive in the mounting bracket (see Figure 22).

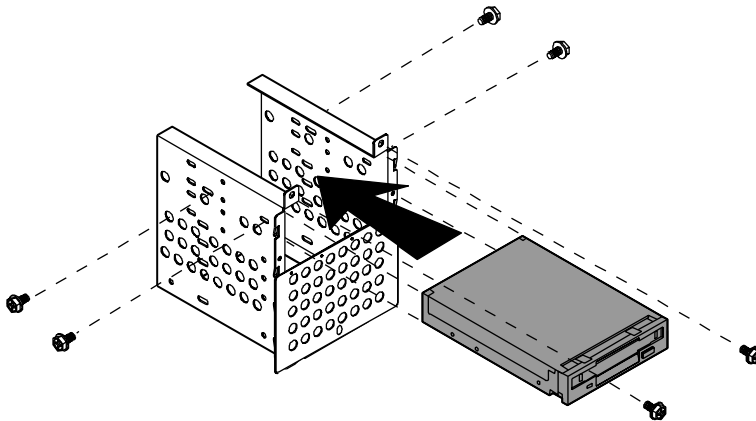

Figure 22: Installing the New 3.5-inch Drive

8. Secure the drive to the mounting bracket using the screws you removed in Step 6.

9. Place the drive bracket in the chassis (see Figure 23). If you are installing a second front-accessible drive, do not reinstall the 3.5-inch metal filler panel when you reinstall the drive bay in the chassis.

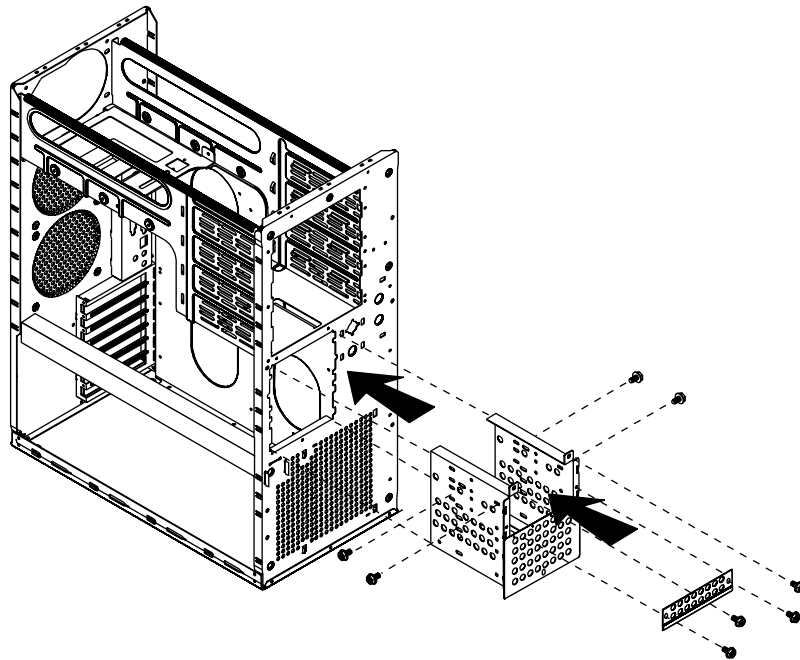

Figure 23: Replacing the Drive Bracket

10. Secure the drive bracket to the chassis with the screws you removed in Step 5.
11. Connect the power and data cables to the 3.5-inch drive, making sure the cables match their original position. (See drive documentation for proper drive jumper settings and cable orientation.)
12. Close the case, as described in “Closing the system” on page 8.
13. Reconnect the power cord and turn on the system.

Installing a drive in the 5.25-inch drive bay

The 5.25-inch drive bay supports a CD-ROM drive, disk drive, or other 5.25-inch device.

To Install a Drive in the 5.25-inch Drive Bay

1. Turn off the system and disconnect the power cord.
2. Open the case (“Opening the system” on page 3), observing the static electricity precautions in “Static electricity precautions” on page 2.
3. Locate the 5.25-inch drive bay.
4. If no drive is installed in the drive bay, remove the metal drive bay cover from the front of the 5.25-inch drive bay. Also, remove the plastic drive bay cover on the front bezel.
5. If you are replacing an existing drive, disconnect the power and data cables from the drive, noting their location and orientation. (You will reconnect these cables after you install the new drive.)
6. Squeeze the tabs at the ends of the guide rails in toward the center of the drive and pull the drive out of the chassis (see Figure 24).

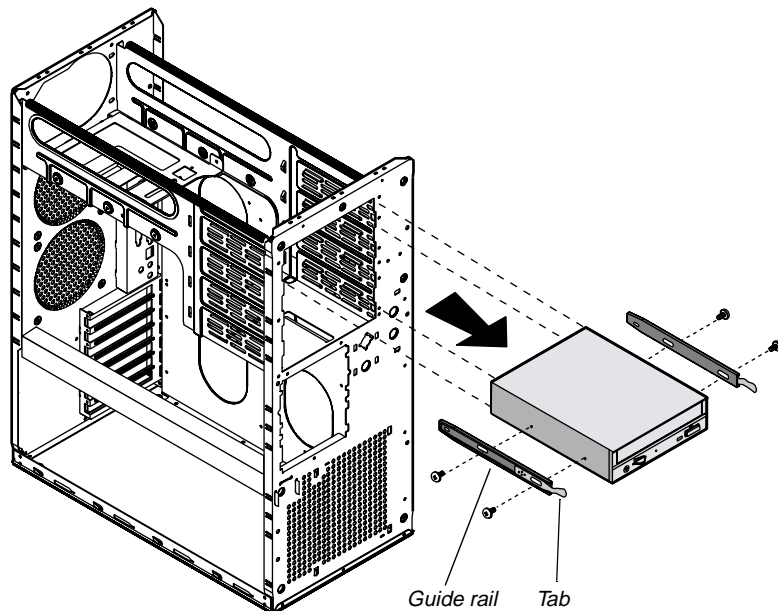

Figure 24: Removing a 5.25-inch Drive

7. Remove the screws that secure the drive rails to the drive and remove the rails.
8. Mount the guide rails to the new drive using the screws you removed from the old drive.
9. Align the guide rails with the rail guides in the drive bay and slide the drive all of the way into the bay. The tabs on the rails will click into place when the drive is fully inserted (see Figure 25).

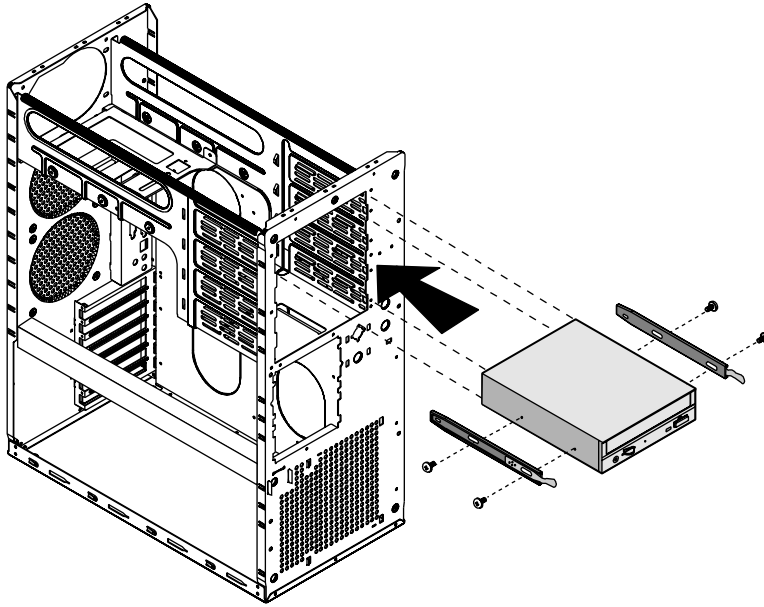

Figure 25: Installing a Drive in the 5.25-Inch Drive Bay

- 10.** Connect the power and data cables to the back of the drive. (See drive documentation for proper drive jumper settings and cable orientation.)
- 11.** Close the case, as described in “Closing the system” on page 8.
- 12.** Reconnect the power cord and turn on the system.
- 13.** Run the configuration software that came with the drive, if required.
- 14.** The system should automatically recognize the new drive. If it does not, you may need to set jumpers on the drive or change settings in the BIOS Setup utility.

Replacing the RAID cage in the 5.25-inch drive bay

The Quick Hot-Swap Drive Cage consists of a drive cage, a locking door, and all the necessary hardware to install it in the system. Each cage supports three drives. Begin cage installation from the bottom drive bay.

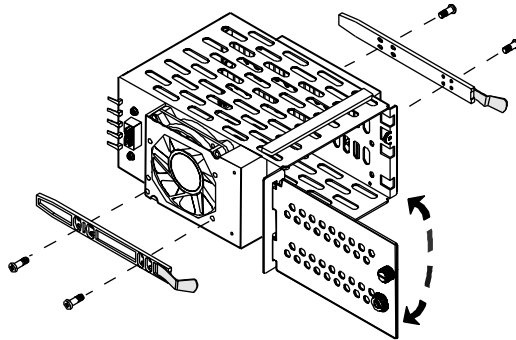

Figure 26: Hot-Swap Drive Cage

To Replace the RAID Cage

1. Remove the side panel as described in “Removing the side panel” on page 3.
2. Disconnect all cables connecting the RAID Cage to other system components.
3. Remove the drives:
 - A. Pull the latching clips outward to release the drive from the RAID Cage (see Figure 27).

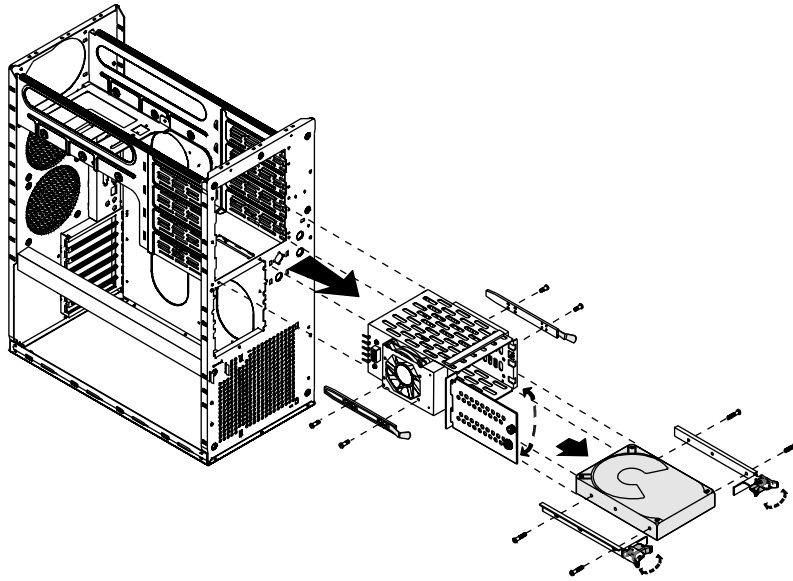

Figure 27: Removing the SCSI Drives

- B.** Pull the drive out of the drive cage.
 - C.** Place the drive in a safe place, preferably in an anti-static bag.
 - D.** Repeat steps a–c for all drives in the drive cage.
- 4.** Remove the old RAID Cage by pressing the tabs on the slide rails toward the center of the cage and pulling the cage out of the 5.25-inch drive bay (see Figure 28).

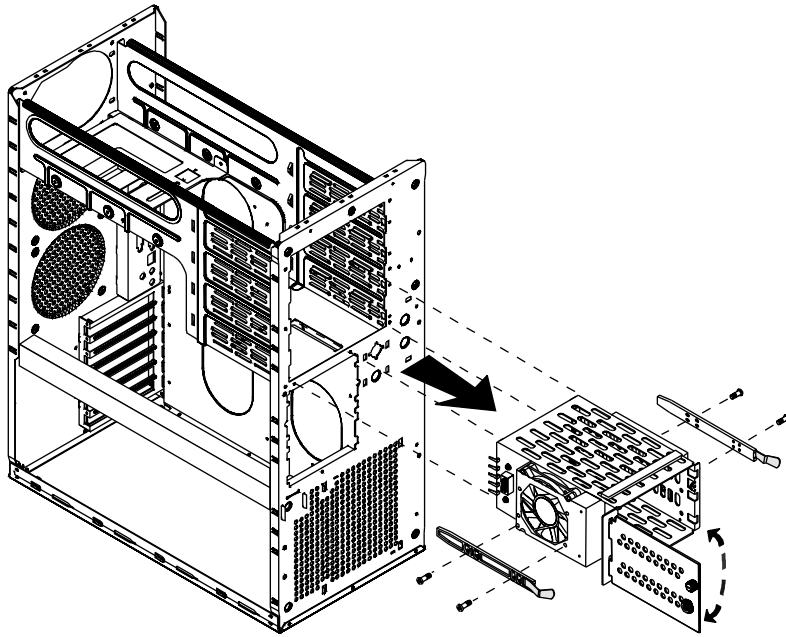

Figure 28: Removing the RAID Cage

Installing the New RAID Cage

1. Slide the new drive cage into the drive bracket as shown in Figure 29.

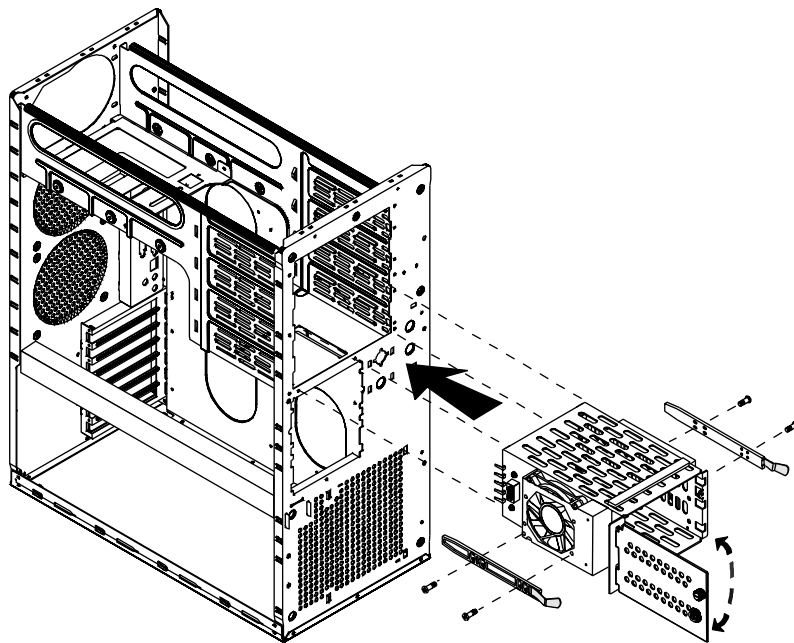

Figure 29: Installing the RAID Cage

2. Connect all cables that connect the RAID Cage and its backplane to other system components.
3. Reinstall the SCSI drives in the new RAID cage by aligning the rails and sliding them all the way into the cage (see Figure 30).

★ **Important!**

Each drive has a Drive Number label affixed to the front of the drive. The drive number on the label corresponds to the device's SCSI ID. Drives must be installed in ascending order starting from the bottom bay.

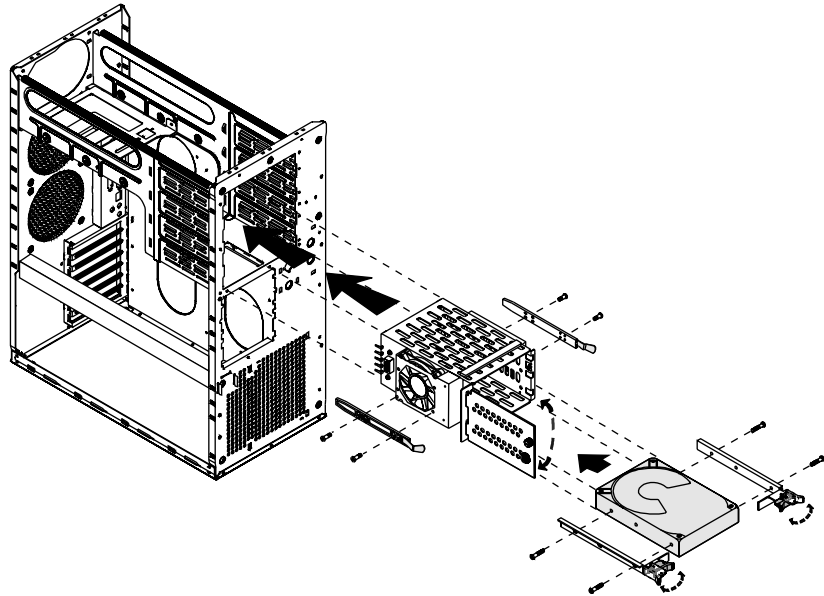

Figure 30: Replacing the SCSI Drives

4. Secure the drives by closing the latching clips.

Replacing a hard disk in the rear drive bay

The hard disk is secured to a metal mounting bracket, which enables the drive to be easily installed and removed from the system chassis. This procedure refers to the internal 3.5-inch drive bay, not to the 3.5-inch bay at the front of the chassis.

To Replace a Hard Drive in the Rear Drive Bay

1. Turn off the system and disconnect the power cord.
2. Open the case (“Opening the system” on page 3), observing the static electricity precautions in “Static electricity precautions” on page 2.
3. Locate the hard disk assembly beneath the power supply at the rear of the chassis.

4. Disconnect the data and power cables from the hard disk drive, noting their location and orientation. (You will reconnect these cables when you install the new hard drive.)
5. Remove the screws that attach the hard disk mounting bracket to the chassis, and remove the bracket from the chassis (see Figure 31).

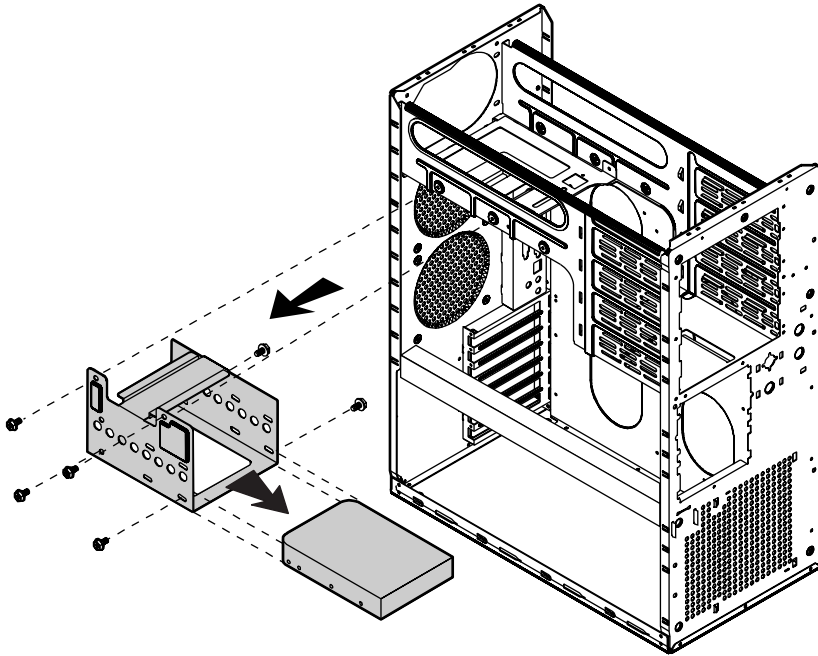

Figure 31: Removing the Hard Disk Bracket and Drive

6. Remove the screws that attach the hard drive to the mounting bracket and remove the hard drive (see Figure 31).
7. Secure the new hard drive to the mounting bracket using the screws you removed in Step 6 (see Figure 32).

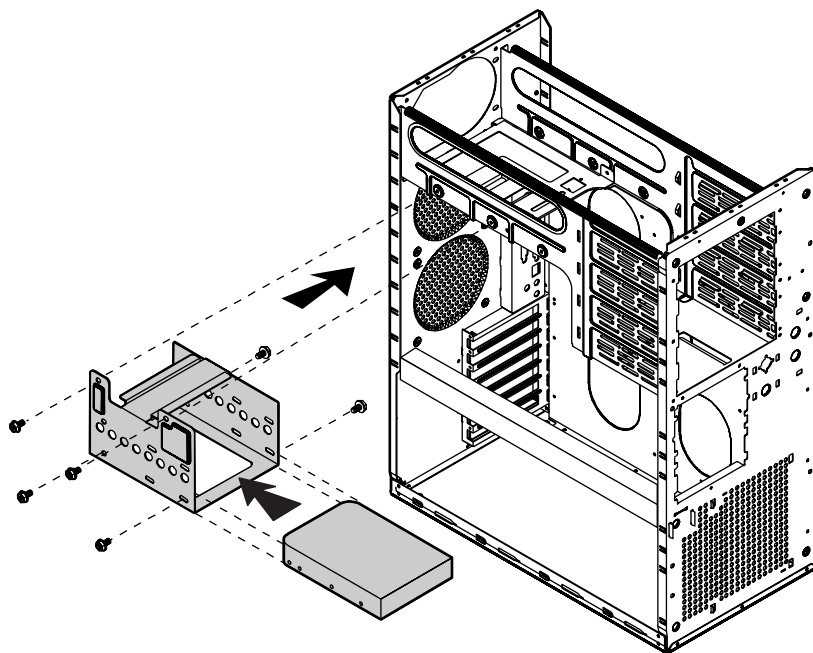

Figure 32: Installing a Hard Drive in the Rear Drive Bay

- 8.** Place the hard disk assembly into the chassis and secure it to the chassis using the screws you removed in Step 5 (see Figure 32).
- 9.** Connect the data and power cables to the hard drive, making sure the cables match their original position. (See the drive documentation for proper drive jumper settings and cable orientation.)
- 10.** Close the case, as described in “Closing the system” on page 8.
- 11.** Reconnect the power cord and turn on the system.
- 12.** The system should automatically recognize the new drive. If it does not, you may need to set jumpers on the drive or change settings in the BIOS Setup utility.

SCSI cable kit installation

The following section describes how to install the SCSI cable kit from the integrated onboard SCSI connector on the system board to the rear panel of the chassis.

The following tools are required to complete the installation:

- Phillips screwdriver
- Straight blade screwdriver
- Anti-static wristband

To install the SCSI cable kit:

1. Power down the system and remove the power cord(s).
2. Remove the parts from the SCSI Cable Kit.
3. Remove the two screws from the rear of the left side cover.
4. Slide the side cover back slightly, then lift it out and off.
5. Using the straight bladed screwdriver, remove the punchout section (insert the blade of the screwdriver into the slot in the punchout, then pry back and fourth until loose).

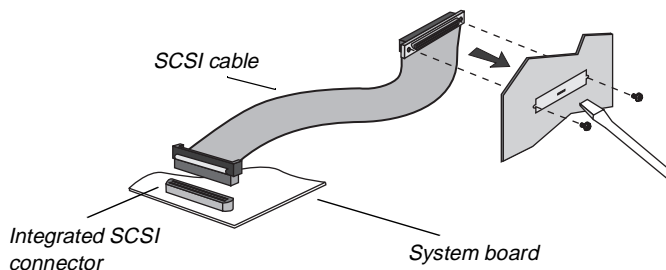

Figure 33: Installing the SCSI Cable Kit

6. One end of the SCSI cable is attached to a bracket containing two threaded holes. From the inside of the system, hold this end of the cable up to the opening created when the punchout was removed.
7. Using the two small screws included in the SCSI Cable Kit, secure the SCSI cable/bracket to the rear panel of the chassis.

▼ Caution!

To help avoid possible damage to your computer from static electricity, follow the anti-static procedures outlined in the Maintenance and Troubleshooting Guide for your system every time you work inside your computer.

8. Plug the other end of the SCSI cable into the appropriate SCSI connector on the system board.
9. Arrange the ribbon cable so that it doesn't interfere with chassis or CPU fans, or block airflow through the system.
10. Reinstall the left side cover of the system and replace the two screws.
11. Plug in the system power cord(s) and power up the system.

Adding an expansion card

The system board has seven (7) expansion slot connectors. The system board accepts two types of expansion cards: ISA and PCI. Some of the PCI expansion slots are designed to allow the slot to be shared with a special purpose expansion card such as a RAIDport card.

Some ISA expansion cards have jumpers or switches that set interrupts and I/O addresses. They come with instructions that explain how to set them to avoid hardware conflicts. Follow the instructions carefully.

Refer to Figure 7 on page 14 for the installation locations.

To Install an Expansion Card

1. Set any jumpers and switches on the card, if required in the card instructions.
2. Turn off the system and disconnect the power cord.
3. Open the case ("Opening the system" on page 3), observing the static electricity precautions in "Static electricity precautions" on page 2.
4. Locate an open slot of the correct type.

5. Remove and retain the screw securing the expansion port cover to the rear cover. Keep the port cover for reinstallation in case you ever need to remove the card (see Figure 34).

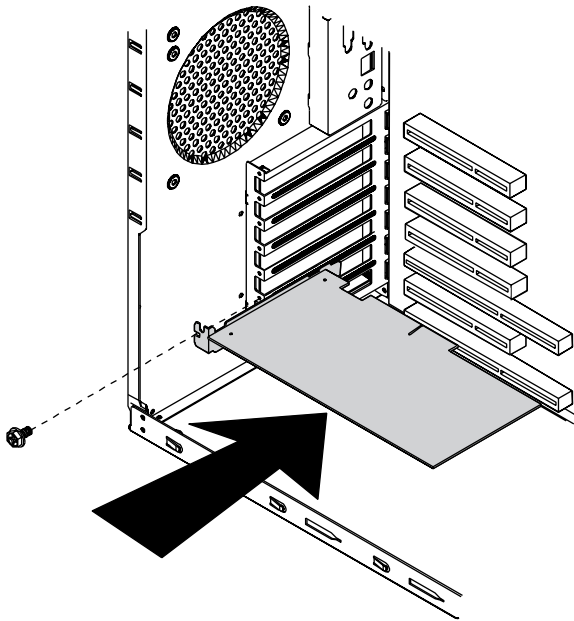

Figure 34: Installing an Expansion Card

6. Firmly insert the edge of the expansion card into the slot.
7. After seating the card firmly, secure it to the chassis by installing the screw you removed in Step 5 through the mounting bracket at the end of the card.
8. If required, connect cables to the card (see card documentation for proper jumper settings and cable orientation)
9. Close the case, as described in “Closing the system” on page 8.
10. Reconnect the power cord and turn on the system.

It may be necessary to reconfigure your system after installing some expansion cards. You may also need to install software that came with the card. Check the card documentation for additional information.

★ *Important!*

For full length cards, make certain that the end of the card is aligned with the correct slot in the card guide. When the card is fully inserted, the plastic retaining clip will snap back out to hold the end of the card in position.

Removing an expansion card

Removing an expansion card may require you to run software to reconfigure the system.

To Remove an Expansion Card

1. Turn off the system and disconnect all power cords and peripheral devices.
2. Open the cover as described in “Opening the system” on page 3, following all static electricity precautions as described in “Static electricity precautions” on page 2.
3. If necessary, disconnect any cables connected to the expansion card.
4. Remove the screw that secures the card and its bracket to the back panel of the server (see Figure 35).

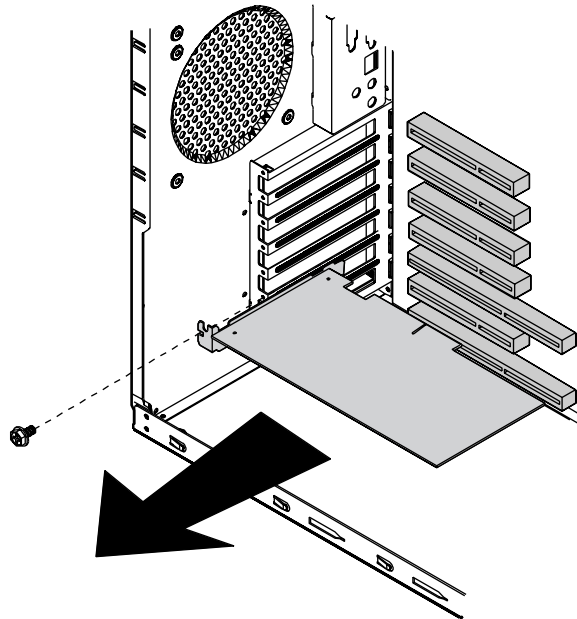

Figure 35: Removing the Expansion Card Screw

5. For full-length cards, press the retaining latch on the card guide in, until it clicks into the retracted position (see Figure 36).

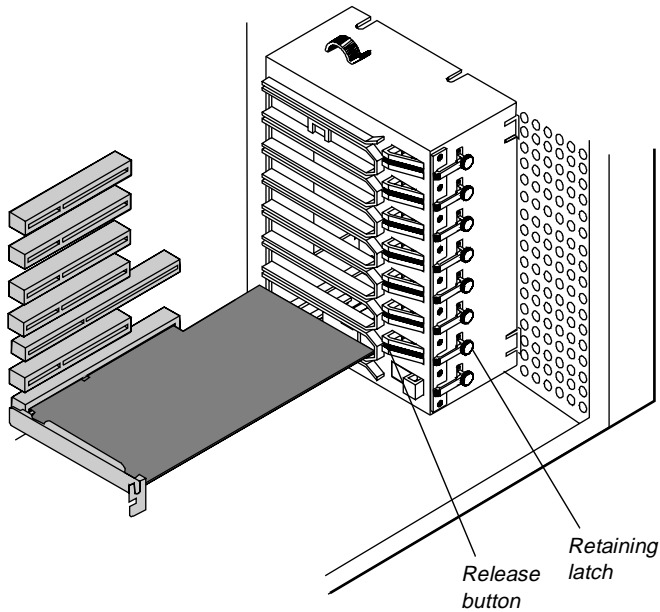

Figure 36: Pressing the Retaining Latch

6. Gently but firmly pull the expansion card out of the chassis.
7. Press the release button on the card guide to return the retaining latch to the extended position.
8. Place an expansion port cover over the empty slot and secure it with the screw you removed earlier.
9. Replace the cover, reconnect the peripherals and power cord, and turn on the system.

Replacing the battery

The battery provides power for the system real-time clock and CMOS RAM, which holds the system configuration information.

To Replace the Battery

Caution!

There is a danger of explosion if the battery is incorrectly replaced. Replace the battery only with the same or equivalent type recommended by the manufacturer. Dispose of used batteries according to the manufacturer's instructions.

1. Restart the computer and start the BIOS Setup program by pressing F2 when you are prompted to do so.
2. Write down the CMOS values from the Main Setup screen so you can reenter them after you replace the battery. (For more information about the setup program, see Chapter 4, “Using the BIOS Setup Utility” on page 62.)
3. Turn off the system and disconnect the power cord.
4. Open the case (“Opening the system” on page 3), observing the static electricity precautions in “Static electricity precautions” on page 2.
5. Locate the battery on the system board, see Figure 7 on page 14. The battery is circular and has the positive pole mark (+) on the top.
6. Gently pull the battery from its socket, and press the new battery in the socket with the positive pole (+) up (see Figure 37). Be sure you have pressed the battery down far enough for it to contact the base of the socket.

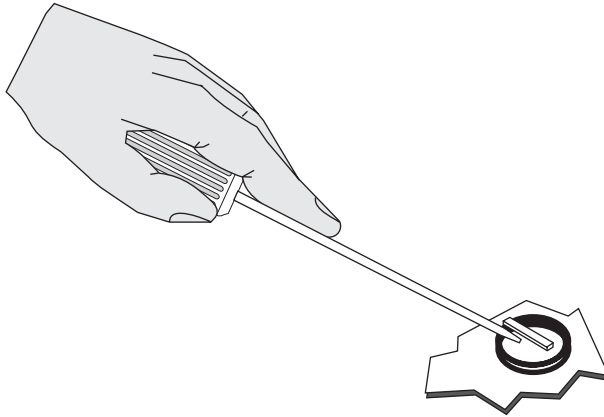

Figure 37: Removing the Battery

7. Close the case, as described in “Closing the system” on page 8.
8. Reconnect the power cord and turn on the system.
9. Enter the BIOS Setup program and verify that the system configuration is correct using the data you recorded in Step 2.

If the CMOS data is not correct, change the information in the setup screens as necessary.

Troubleshooting the battery installation

If you have problems after installing the new battery, try each of the items listed below, replacing the cover and restarting the computer after each try.

- Turn off the system and ensure that all exterior cables are attached to the correct connectors and secured.
- Check to be sure that all power switches are on. If the system is plugged into a power strip or surge protector, be sure it is turned on also.
- Enter the BIOS Setup program and compare the settings on the screen with your notes or the system hardware manuals. Correct any discrepancies.

- Turn off the system, remove the cover, and verify that all cables inside the case are attached securely. Also, make sure that the colored cable edges are aligned correctly and that the connectors do not miss any pins. Disconnect and reconnect the cables, and then replace the cover carefully so as not to disturb any cables.
- Turn off the system, remove the cover and, if you have the proper test equipment, verify that the new battery has power. (It is possible, although highly unlikely, that your new battery is defective.)

If these procedures fail to correct the problem, contact Technical Support.

When everything works properly, close the case as described in “Closing the system” on page 8, reconnect the power cord, and turn on the system.

Installing software and drivers

Installing software and drivers is usually specific to the operating system you run on the system. However, some tips on installing drivers or other software in critical situations or under particular circumstances are provided below.

Installing the video drivers

The integrated video controller on the system board uses standard drivers provided with the system utilities diskettes. For those running Windows NT in particular, use the driver provided on the utilities diskettes (Cirrus Logic Windows NT 4.0 v1.40 diskette) not those provided on the Windows NT installation CD-ROM. The drivers provided on the Windows NT CD-ROM may not function correctly.

Video driver installation varies depending on the operating system that you run on the server. Refer to the documentation for the operating system for specific instructions.

If you are using an add-in video controller, the drivers should have accompanied the controller card. See the documentation that accompanied the controller card for instructions and information regarding the drivers for an add-in video card.

NetWare 4.11 drivers and Seagate Backup Exec issues

NetWare 4.11 driver issues:

When installing the second instance driver for the second SCSI controller, the server will generate interrupts which hang the server. To resolve this issue, replace the MPS14.PSM file that is installed during the NetWare 4.11 installation with an updated version of the file. The updated file can be obtained from the Netware Service Pack 5 utility patch provided by Novell. The following are two methods that can be used to updated the MPS14.PSM file:

1. After NetWare is installed and before loading the second on-board SCSI driver, the updated MPS14.PSM file can be copied to the C:\NWSERVER subdirectory to overwrite the older version placed during installation. Restart the server and the second on-board SCSI driver will load successfully.
2. During the NetWare installation, select SMP support, a message to install an unlisted PSM file will display. Path to the location of the updated PSM file and load it. Once loaded, the updated PSM file will automatically be copied to the NetWare installation directory. Once the file has been copied you can successfully load the second on-board SCSI driver.

Seagate Backup Exec issues:

Once Seagate Backup Exec has been installed and the program started, the CLIB and DSAPI modules report errors while loading. Backup Exec will continue to run after the errors appear. Backup Exec recommends that these files be updated to a later version. The updated files can be obtained from Novell's website at the following location:

<http://support.novell.com/cgi-bin/search/download?/pug/updates/nw/i/nw411/libuph.exe&sr>

The update files are CLIB.NLM and DSAPI.NLM.



BIOS Setup

About the BIOS Setup Utility	62
Using the BIOS Setup Utility.....	62
Updating the BIOS	81

About the BIOS Setup Utility

The computer BIOS has a built-in program that lets you set many basic system characteristics. These settings are stored and saved even when the power is off. This chapter contains information about this setup utility and is intended to serve as a guide so that you can make changes to your system BIOS when necessary.

Many of the screen examples that you see in this chapter are identical to what you see on your monitor; however, you may have a system with a newer BIOS version than the one described in this manual. In that case, some of the examples may differ somewhat from what you see, but the screens are similar enough that you should have no trouble getting the information that you need.

Using the BIOS Setup Utility

The computer BIOS has a built-in setup utility that lets you configure several basic system characteristics. The settings are stored in battery-backed CMOS memory and are retained even when the power is off.

To enter the setup utility, restart the system and then press F2 when prompted on screen during the startup process. Upon entering setup, the Main Setup screen opens.

F1 Help	↑↓ Select Item	+/- Change Values	F9 Setup Defaults
ESC Exit	←→ Select Menu	ENTER Select ► Sub-Menu	F10 Save and Exit

Figure 38: BIOS Menu Navigation Keystrokes

The lower section of all screens provides information about keystrokes necessary to access help, navigate through the menus, and perform other functions.

- **Help**—Press F1 to get information about the selected item. This item is only usable in a submenu.
- **Exit**—Press ESC to back out of any field.
- **Select Item**—Press the up arrow or down arrow keys to move to the next or previous menu item.

- **Select Menu**—Use the left arrow and right arrow keys to move between the six main menus (Main, Advanced, Security, Power, Boot and Exit).
- **Change Values**—Use the plus (+) key or the minus (-) key to toggle through the available options for the selected item.
- **Select > Sub-Menu**— Pressing ENTER when a sub-menu is highlighted takes you to that sub-menu.
- **Setup Defaults**—Press F9 to set the setup parameters to their factory default values. A submenu appears, asking you to press either ENTER to load the defaults or ESC to skip.
- **Save & Exit**—Press F10 to exit the setup utility and either save or ignore all changes. A submenu appears, asking you to press ENTER to save the changes or ESC to ignore the changes and exit.

Main menu screen

The main menu screen allows you to access the most common setup fields.

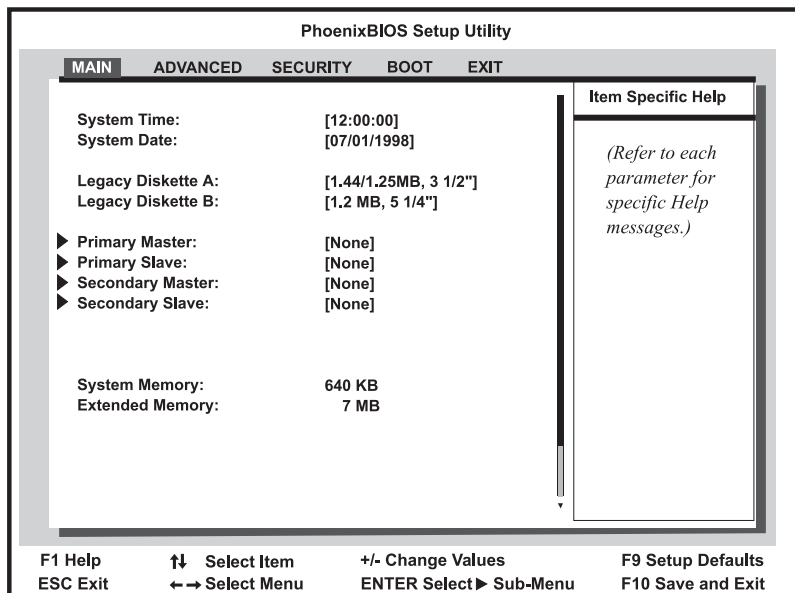

Figure 39: Main Menu Screen

- **System Time** lets you set the system time. Use a twenty-four hour clock in the format HH:MM:SS.
- **System Date** lets you set the system date, using the format MM:DD:YYYY.
- **Legacy Diskette A:** allows you to select the type of diskette drive installed as drive A. The options are **360 kB, 5 ¼”**; **1.2 MB, 5 ¼”**; **720 kB, 3 ½”**; **1.44/1.25 MB, 3 ½”**; **2.88 MB, 3 ½”**; **Not installed**; and **Disabled**.
- **Legacy Diskette B:** allows you to select the type of diskette drive installed as drive B. The options are **360 kB, 5 ¼”**; **1.2 MB, 5 ¼”**; **720 kB, 3 ½”**; **1.44/1.25 MB, 3 ½”**; **2.88 MB, 3 ½”**; **Not installed**; and **Disabled**.
- **Primary Master:** opens the Primary Master screen to permit you to setup the primary master hard disk drive. Details of this screen are provided in the section “Hard disk drive setup screen” on page 65.
- **Primary Slave:** opens the Primary Slave screen to permit you to setup the primary slave hard disk drive. Details of this screen are provided in the section “Hard disk drive setup screen” on page 65.
- **Secondary Master:** opens the Secondary Master screen to permit you to setup the secondary master hard disk drive. Details of this screen are provided in the section “Hard disk drive setup screen” on page 65.
- **Secondary Slave:** opens the Secondary Slave screen to permit you to setup the secondary slave hard disk drive. Details of this screen are provided in the section “Hard disk drive setup screen” on page 65.
- **System Memory:** shows the amount of base system memory detected.
- **Extended Memory:** shows the amount of extended memory detected.

Hard disk drive setup screen

The hard disk drive setup screen appears whenever the **Primary Master**, **Primary Slave**, **Secondary Master**, or **Secondary Slave** fields are selected from the main menu screen.

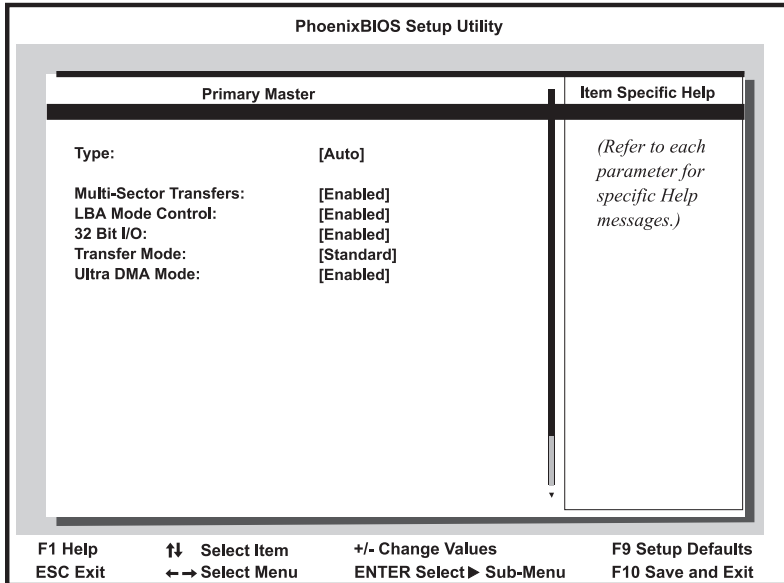

Figure 40: Example Hard Disk Drive Setup Screen

- **Type** offers the following options:
 - **User** - selecting this option brings up a sub-menu where you can enter the **Cylinders, Heads, Sectors** and **Maximum Capacity** of the drive you are configuring. These values are generally available from the documentation for the drive or the drive label itself.
 - **Auto** - selecting this option automatically configures the drive based on information from the drive itself.
 - **CD-ROM** - select this option if the drive is a CD-ROM.
 - **None** - "Auto" has been unable to supply the drive type or you have deliberately selected "None," disabling any drive that may be installed.

- **Multi-Sector Transfers:** enabling this option allows multiple sector data transfers on compatible drives. The options are **Disabled, Standard, 2 Sectors, 4 Sectors, 8 Sectors,** and **16 Sectors.**
- **LBA Mode Control:** enabling this option causes Logical Block Addressing to be used in place of Cylinders, Heads and Sectors. The options are **Enabled** and **Disabled.**
- **32 Bit I/O:** enabling this option allows 32-bit communication between the processor and the IDE controller. The options are **Enabled** and **Disabled.**
- **Transfer Mode:** selects the method for moving data to and from the drive. The options listed are those supported by the drive and the platform; either **Standard, Fast PIO 1, Fast PIO 2, Fast PIO 3,** and **Fast PIO 4;** or **Standard, FPIO3/DMA1,** and **FPIO4/DMA2.**
- **Ultra DMA Mode:** enabling this option allows a faster data transfer rate with compatible drives. The options are **Mode 0,** **Mode 1,** and **Mode 2.**

Advanced menu screen

The advanced menu screen allows you to access a large number of advanced features. Many of these features can cause the system to malfunction if set incorrectly. Do not change these settings unless you must.

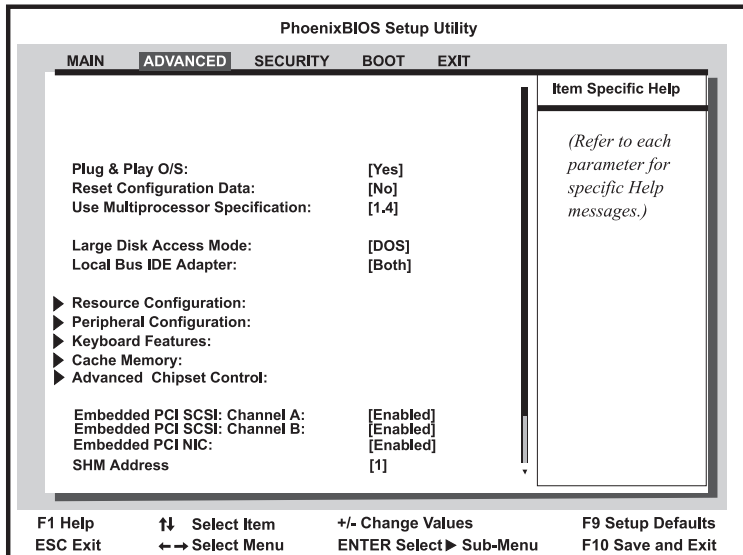

Figure 41: Advanced Menu Screen

- **Plug and Play O/S:** specifies whether the operating system is compatible with Plug and Play. The options are **Yes** and **No**.
- **Reset Configuration Data:** selecting **Yes** causes the system to clear its configuration data and automatically configure all PnP devices at bootup. Selecting **No** causes the system to use the existing configuration information.
- **Use Multiprocessor Specification:** configures the multiprocessor specification for compatibility reasons. Specification 1.4 allows extended bus definitions and is required to permit a secondary PCI bus to work without a bridge. However, some operating systems require Specification 1.1 for compatibility reasons.

- **Large Disk Access Mode:** options include **DOS** and **Other**. Select **DOS** if you are using DOS or one of the DOS-based operating systems. Select **Other** if you are using another operating system such as UNIX. A large disk is considered one that has more than 1024 cylinders, 16 heads, or 63 tracks per sector.
- **Local Bus IDE Adapter** enables or disables the two channels of the onboard IDE adapter. The options are **Disable**, **Primary**, **Secondary**, and **Both**.
- **Resource Configuration** opens the Resource Configuration screen. Details of this screen are provided in the section, “Resource configuration screen” on page 69.
- **Peripheral Configuration** opens the Peripheral Configuration screen. Details of this screen are provided in the section, “Peripheral configuration screen” on page 72.
- **Keyboard Features** opens the Keyboard Configuration screen. Details of this screen are provided in the section “Keyboard features screen” on page 74.
- **Cache Memory** opens the Cache Memory Configuration screen. Details of this screen are provided in the section “Cache memory screen” on page 75.
- **Advanced Chipset Control** opens the advanced chipset control screen which contains a single field. The field is **ECC Config**, which allows you to set the extent of error checking and correction that the system uses. The options for this field are **Disabled**, **EC**, **ECC**, and **ECC Scrub**.
- **Embedded PCI SCSI: Channel A** enabling this field turns on channel A of the optional integrated SCSI adapter. Select the Scan First option if the server will boot from a hard disk or select the Scan Last option if the server will boot from a CD-ROM. The options are **Enabled** and **Disabled**.
- **Embedded PCI SCSI: Channel B** enabling this field turns on channel B of the optional integrated SCSI adapter. Select the Scan First option if the server will boot from a hard disk or select the Scan Last option if the server will boot from a CD-ROM. The options are **Enabled** and **Disabled**.

- **Embedded PCI NIC:** enabling turns on the optional integrated network interface controller (NIC). The options are **Enabled** and **Disabled**.
- **SHM Address:** defines the System Hardware Manager (SHM) address. The options are 1 through 7.

★ *Important!*

The SHM Address is always 1 in stand-alone configurations.

Resource configuration screen

This screen appears whenever **Resource Configuration** is selected off of the advanced menu screen.

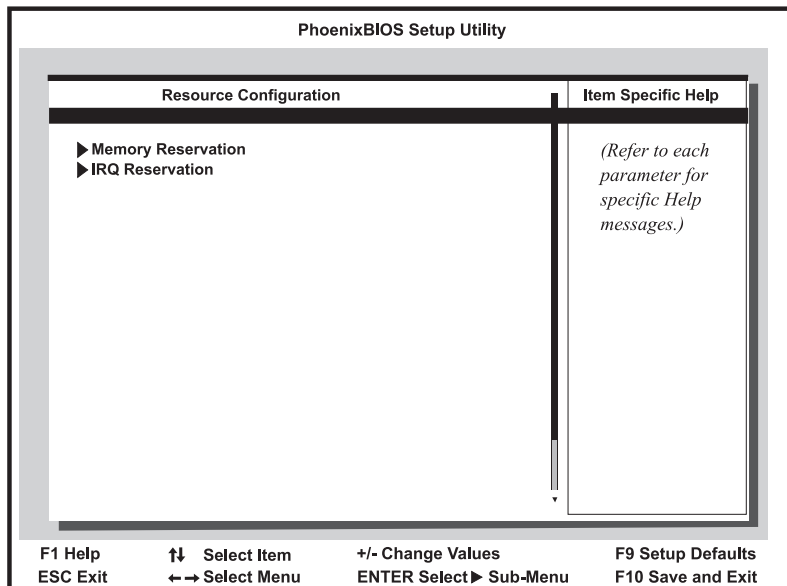

Figure 42: Resource Configuration Screen

- **Memory Reservation:** opens the Memory Reservation screen. This screen allows you to reserve blocks of upper memory for use by legacy ISA devices. Details of this screen are provided in the section “Memory Reservation Screen” on page 70.
- **IRQ Reservation:** opens the IRQ Reservation screen. This screen allows you to reserve IRQs for use by legacy ISA devices. Details of this screen are provided in the section “IRQ Reservation Screen” on page 70.

Memory Reservation Screen

This screen appears whenever **Memory Reservation** is selected from the resource configuration screen. It allows you to reserve blocks of memory for ISA devices.

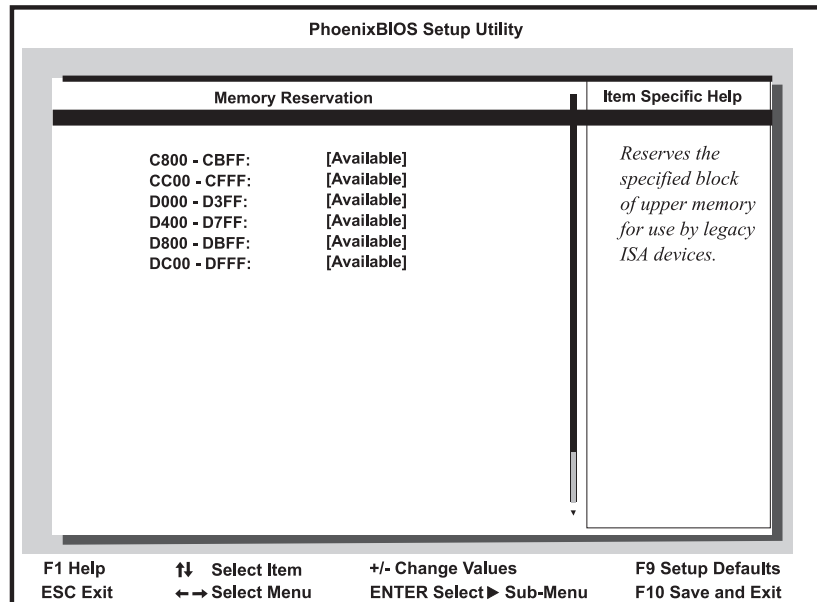

Figure 43: Memory Reservation Screen

- **XXXX – XXXX**: the specified area of upper memory may be reserved for use by legacy ISA devices. Options are **Available** and **Reserved**.

IRQ Reservation Screen

This screen appears whenever you select **IRQ Reservation** from the advanced menu screen. It allows you to manually reserve IRQs for specific devices.

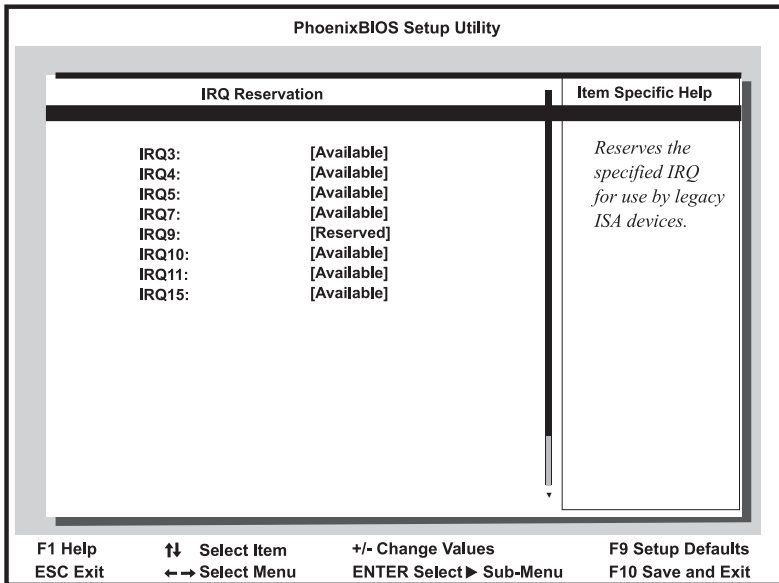

Figure 44: IRQ Reservation Screen

- IRQx: the specified IRQ may be reserved for use by legacy ISA devices. Options are **Available** and **Reserved**.

Peripheral configuration screen

This screen allows you to configure the system peripherals.

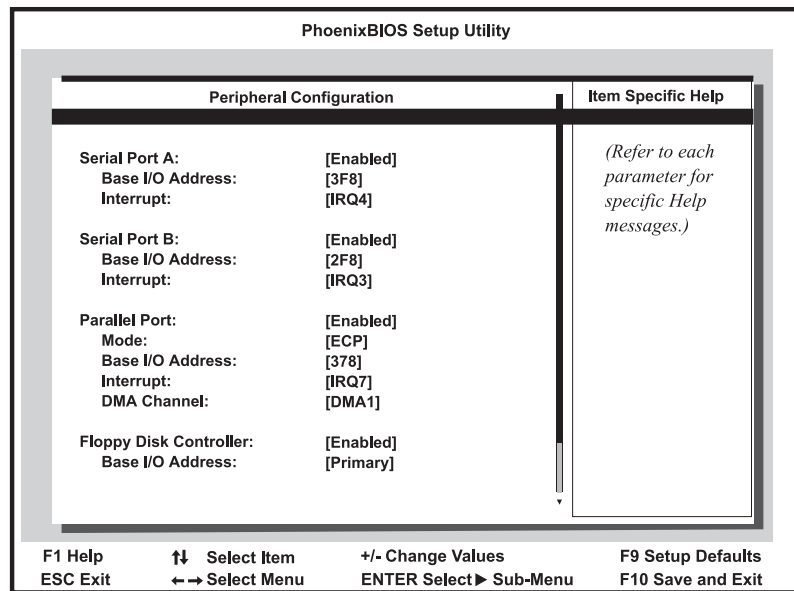

Figure 45: Peripheral Configuration Screen

- **Serial Port A:** allows you to set the characteristics of serial port A. Options include **Enabled**, **Disabled** and **Auto**.
 - **Base I/O Address:** displays the base I/O address for integrated Serial Port A. Using the + or - key displays the optional addresses available.
 - **Interrupt:** displays the current interrupt for integrated Serial Port A. Using the + or - key displays the optional interrupts available.
- **Serial Port B:** allows you to set the characteristics of serial port B. Options include **Enabled**, **Disabled** and **Auto**.
 - **Base I/O Address:** displays the base I/O address for integrated Serial Port B. Using the + or - key displays the optional addresses available.

- **Interrupt:** displays the current interrupt for integrated Serial Port B. Using the + or - key displays the optional interrupts available.
- **Parallel Port:** allows you to set the characteristics of the integrated parallel port. Options include **Enabled, Disabled, Auto, and OS Controlled.**
 - **Mode:** displays the current parallel port mode. Options include **ECP (Extended Capabilities Port), Bi-directional and Output Only.**
 - **Base I/O Address:** displays the base I/O address for the integrated Parallel Port. Using the + or - key displays the optional addresses available.
 - **Interrupt:** displays the current interrupt for the integrated Parallel Port. Using the + or - key displays the optional interrupts available.
 - **DMA Channel:** displays the current DMA channel used by the Parallel Port. Using the + or - key displays the optional channels available.
- **Floppy Disk Controller:** controls the integrated diskette drive controller. Options include **Enable** and **Disable.**
 - **Base I/O Address:** displays the base I/O address for the integrated diskette controller. Options include **Primary** and **Secondary.**

Keyboard features screen

This screen allows you to configure the features of your keyboard.

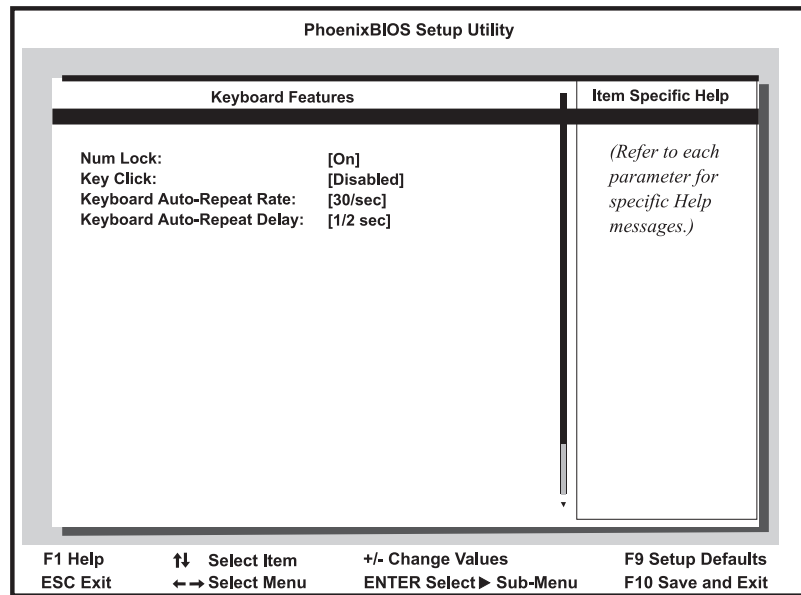

Figure 46: Keyboard Features Screen

- **Num Lock:** options include **Auto**, **On** and **Off**. Sets the power-on state of the NUM LOCK key.
- **Key Click:** options are **Enabled** and **Disabled**. Enable causes an audible click when each key is pressed.
- **Keyboard Auto-Repeat Rate:** determines the rate at which a character repeats if a key is held down. Options are **2/sec**, **6/sec**, **10/sec**, **13.3/sec**, **18.5/sec**, **21.8/sec**, **26.7/sec**, and **30/sec**.
- **Keyboard Auto-Repeat Delay:** determines the amount of delay before a pressed key repeats. Options are **1/4 sec**, **1/2 sec**, **3/4 sec**, and **1 sec**.

Cache memory screen

This screen allows you to configure various aspects of the system cache memory.

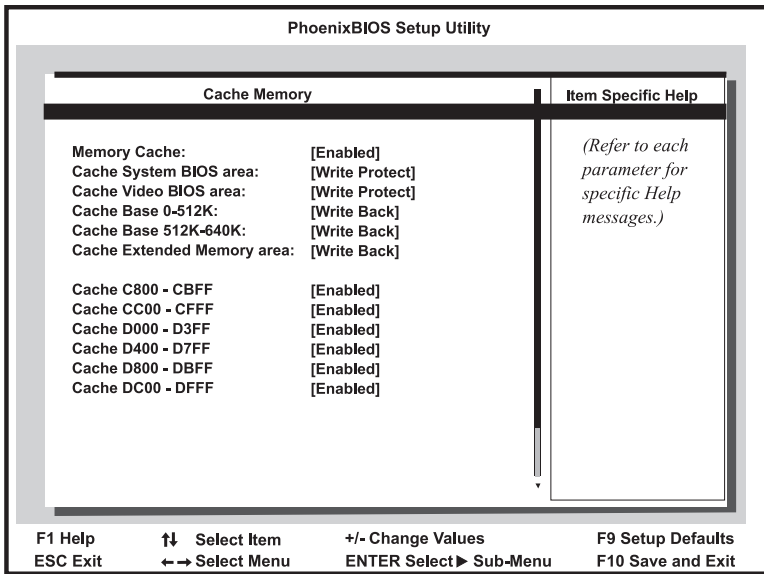

Figure 47: Cache Memory Screen

- **Memory Cache:** allows you to disable the L1 and L2 memory caches. Options include **Enabled** or **Disabled**. Normally used to troubleshoot speed-related problems.
- **Cache System BIOS Area:** controls the caching of the system BIOS area. Options are **Uncached** or **Write Protect**.
- **Cache Video BIOS Area:** controls the caching of the video BIOS area. Options are **Uncached** or **Write Protect**.
- **Cache Base 0-512K:** controls caching of the first 512KB of base memory. Options are **Write Back**, **Write Through**, **Uncached** and **Write Protect**.
- **Cache Base 512K-640K:** controls caching of the 512KB through 640KB area of base memory. Options are **Write Back**, **Write Through**, **Uncached**, and **Write Protect**.

- **Cache Extended Memory Area:** controls caching of the system memory above 1 MB. Options are **Uncached**, **Write Through**, **Write Protect**, and **Write Back**.
- **Cache segments (e.g., C800 - CBFF):** controls caching of the specified segments of memory. Options are **Disabled**, **Write Through**, **Write Protect**, and **Write Back**.
- **MSCS Support:** Options are **Enabled** and **Disabled**. Enable to support Microsoft Cluster.

Security menu screen

This screen allows you to set system security characteristics.

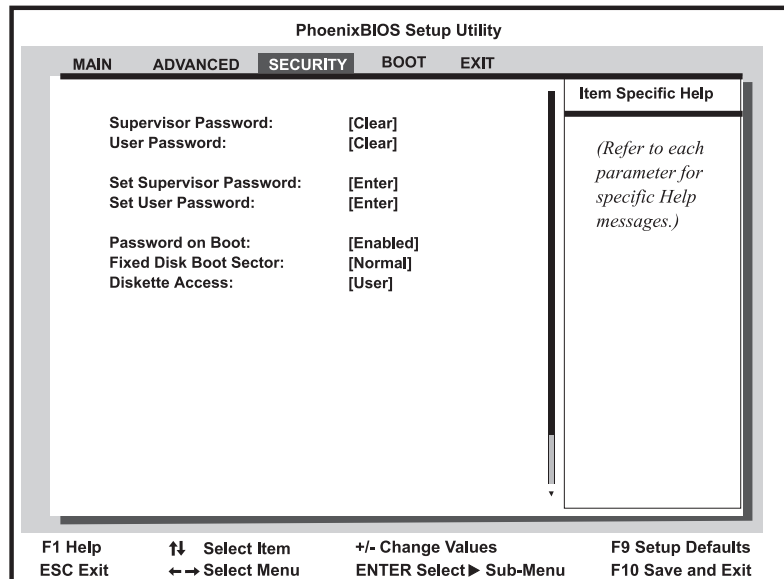

Figure 48: Security Menu Screen

- **Supervisor Password:** displays the status of the administrative password. Options are **Clear** (no password entered) and **Set** (a password has been established).
- **User Password:** displays the status of the user password. Options are **Clear** (no password entered) and **Set** (a password has been established).

- **Set Supervisor Password** opens the supervisor password menu. In this box, the supervisor can enter and verify the password used to control access to the setup utility. If the supervisor password has already been set, the supervisor must enter the current password before being able to enter and verify a new password.
- **Set User Password** shows the user password menu. In this box, you can enter and verify the password used to control access to the system at boot. If the user password has already been set, you must enter the current password before you are able to enter and verify a new password.
- **Password on Boot:** when this option is enabled, the system prompts you for a password before booting the system.
- **Fixed Disk Boot Sector:** allows you to write-protect the boot sector of the primary boot disk to protect the system from viruses. Options for this field are **Normal** and **Write Protect**.
- **Diskette Access:** controls access to the diskette drive. Options include **Supervisor** (diskette drive is accessible only to the supervisor) and **User** (diskette drive is accessible to any user).

Boot menu screen

This screen allows you to set the order in which the system seeks boot data.

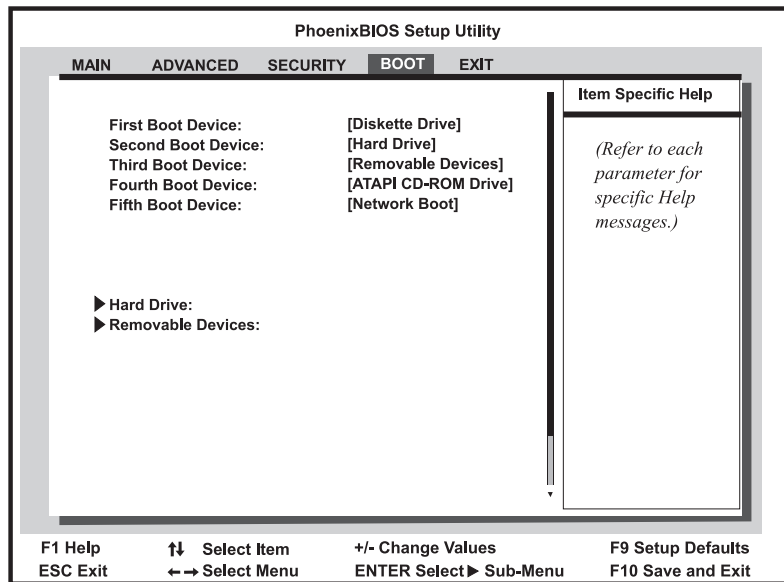

Figure 49: Boot Menu Screen

- **First Boot Device:** designates the device that the system polls first upon boot up. Options include **Diskette Drive, Hard Drive, Removable Devices, ATAPI CD-ROM Drive, and Network Boot.**
- **Second Boot Device:** designates the device that the system polls second upon boot up, assuming that it finds no boot data on the previously designated device. Options include **Diskette Drive, Hard Drive, Removable Devices, ATAPI CD-ROM Drive, and Network Boot.**
- **Third Boot Device:** designates the device that the system polls third upon boot up, assuming that it finds no boot data on the previously designated device. Options include **Diskette Drive, Hard Drive, Removable Devices, ATAPI CD-ROM Drive, and Network Boot.**

- **Fourth Boot Device:** designates the device that the system polls fourth upon boot up, assuming that it finds no boot data on the previously designated device. Options include **Diskette Drive, Hard Drive, Removable Devices, ATAPI CD-ROM Drive, and Network Boot.**
- **Fifth Boot Device:** designates the device that the system polls fifth upon boot up, assuming that it finds no boot data on the previously designated device. Options include **Diskette Drive, Hard Drive, Removable Devices, ATAPI CD-ROM Drive, and Network Boot.**
- **Hard Drive:** displays a list of available hard drives. The system attempts to boot to the operating system from the first hard drive on this list. If no operating system is found, the system tries the next drive listed until an operating system is found or there are no more hard drives on the list. Use the up and down arrows to select a device, then press (+) or (-) to move it up or down the list.
- **Removable Devices:** displays a list of available removable devices. The system assigns drive letters to these devices in the order displayed. To change the sequence and drive letter of a device, use the up and down arrows to select a device, then press (+) or (-) to move it up or down the list.

Exit menu screen

This screen allows you to exit the Setup program or to save any changes you have made to the BIOS settings.

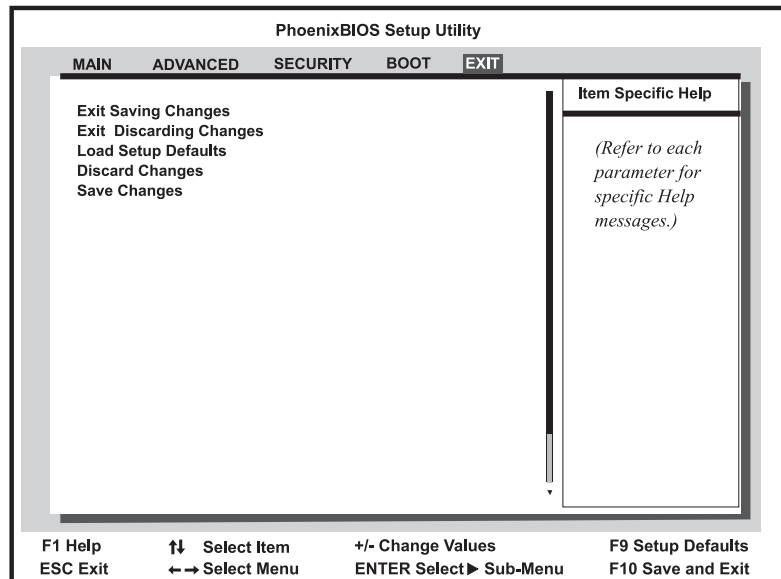

Figure 50: Exit Menu Screen

- **Exit Saving Changes:** exits BIOS Setup and saves the changes you have entered in the CMOS. The next time you boot the system, the BIOS configures your system using the new settings.
- **Exit Discarding Changes:** exits BIOS Setup and discards the settings you have entered. The next time you boot the system, the BIOS configures your system using the old settings.
- **Load Setup Defaults:** displays the setup defaults in cases where the settings have been corrupted or incorrectly modified. Press F1 to resume the boot, or F2 to run BIOS Setup with the ROM default values already loaded into the menus.
- **Discard Changes:** restores the CMOS settings previously entered (not the default values) and discards the changes entered in the current session, without exiting the BIOS Setup.
- **Save Changes:** saves the changes you have made during the current session, without exiting Setup.

Updating the BIOS

Flash memory simplifies distributing BIOS upgrades. If you need a new version of the BIOS, you can download the BIOS update from the Technical Support web site and install the new version from a disk.

To Update the BIOS

1. Enter BIOS Setup by pressing F2 when prompted during startup.
2. Write down the settings for each of the fields. (At the end of the BIOS update process, you will reset the fields to the default values.)
3. Exit the BIOS Setup program.
4. Download the correct BIOS file from the Technical Support web site.
5. Uncompress the contents of the BIOS file you downloaded, and copy the contents onto a bootable diskette.
6. Place the bootable diskette containing the BIOS files into drive A, and restart the system with the disk in the drive.
7. At the prompt, type:

PROGGTW

and press ENTER.
8. The system asks you if you want to change the BIOS. Press Y and then press ENTER.
9. Once the BIOS files have been loaded, remove the disk from drive A and restart the system.
10. As the system starts up, verify that the correct BIOS version is reported.
11. Enter BIOS Setup by pressing F2 when prompted during startup. Once in BIOS Setup, re-enter the values you wrote down at the beginning of this process.

If you do not set the CMOS values back to the correct values, the system may function erratically.

★ *Important!*

You may encounter a CMOS checksum error or other problem after the system restarts. Try turning the system off and then restarting. CMOS checksum errors require that you enter BIOS Setup, check your settings, save your settings, and exit setup.



Troubleshooting

Introduction.....	84
Computer virus notice	84
Troubleshooting checklist.....	85
CD-ROM problems.....	87
Hard disk problems.....	88
Memory/Processor problems.....	89
Modem problems.....	90
Peripheral/Adapter problems	91
Printer problems	93
System problems	94
Video problems.....	95
Error messages.....	98

★ *Important!*

Under no circumstances return any equipment without obtaining a Return Material Authorization (RMA) number.

Introduction

If your system does not operate correctly, re-read the instructions for the procedure(s) you have performed. If an error occurs within an application, consult the documentation supplied with the software.

This section identifies solutions to common problems. If the suggestions in this chapter do not resolve your problem, try calling Technical Support.

Computer virus notice

A virus is a program written with malicious intent for the sole purpose of creating havoc in a computer system. It attaches itself to executable files or boot sectors, so it can replicate and spread. Some viruses may only cause the system to beep or display messages or images on the screen. Other viruses are highly destructive and corrupt or erase the contents of files or disks. To be safe, never assume any virus is harmless.

Viruses are identified by how they infect the computer.

- **Program Viruses** infect executable program files such as .COM, .EXE, .OVL, .DRV, .SYS, and .BIN.
- **Macro Viruses** infect the data files of specific programs. These viruses are written in the macro languages certain applications use to enhance their functionality. These viruses do not infect other programs or the boot sector.
- **Boot Viruses** attach themselves to a Boot Record, Master Boot, FAT, or Partition Table.
- **Multipartite Viruses** are both program and boot infectors.

Viruses are inactive until the infected program is executed, or a boot record is read. Thereafter, the virus loads itself into system memory and begins to copy and spread itself. Diskettes used in a contaminated system can get infected and, in turn, transfer the virus when used in another system. A virus can also spread via programs downloaded from bulletin boards or the Internet.

To Prevent Virus Infection

- Obtain an anti-virus program and make it a habit to scan the system regularly.
- Make backup copies of all files and write-protect the disks.
- Obtain all software from reputable sources and always scan new software for any viruses prior to installing files.

If the system has been infected, find and remove the viruses using an anti-virus program. Then turn off the system for a minimum of 15 seconds to clear the virus from system RAM. You may want to rerun the anti-virus software when you turn the system back on to verify that the system is clean.

Troubleshooting checklist

Before turning on the system, make sure that:

- The power cord is connected to the AC power-in connector and an AC outlet.
- The AC outlet is supplying power.
- If you use a power strip, you have turned it on, and set the circuit breaker.
- The voltage selection switch on the system power supply reflects the proper voltage.

Verifying your configuration

If your system is not operating correctly, the BIOS may contain an invalid configuration parameter. Enter the BIOS program and check your configuration settings.

Troubleshooting guidelines

As you troubleshoot your system, keep the following guidelines in mind:

- Never remove the system cover while the system is turned on.
- Do not attempt to open the monitor; it is extremely dangerous. Even if the monitor power is disconnected, stored energy within the components can cause a painful or harmful shock.
- If a peripheral such as the keyboard, mouse, drive, or printer does not appear to work, verify that all connections are secure.
- If the system displays an error message on the screen, write it down word-for-word. You may be asked about it when calling Technical Support.
- Only qualified personnel should open the system for maintenance.
- If you are qualified to maintain the system yourself, make certain you are properly grounded before opening the system chassis. See “Static electricity precautions” on page 2 for more information on preventing electrostatic damage to the system.

CD-ROM problems

An audio CD produces no sound.

Probable Cause	Solution
The CD is loaded incorrectly.	Make certain the label is facing upward, and then try again.
The speakers are not connected.	Check the speaker cables. Make certain they are connected properly and securely.
The speaker volume is turned down.	Check the volume control.
The speakers may be muted via the Multimedia volume control.	From the Accessories menu (Start Programs Accessories), click Multimedia , and then click Volume Control . Make certain the volume is turned up.
The sound card may not be installed correctly.	Open the system, and then reseal the sound card. Make certain the cables are connected properly.
The speakers may be faulty.	Connect a set of headphones to the speaker jack to test the output. If they work, replace the speakers.

★ *Important!*

Some systems do not have sound cards because sound capabilities are built into the system board.

The CD-ROM drive is not recognized by the system.

Probable Cause	Solution
The CD is not intended for PC use.	Make certain the CD is PC-compatible.
The CD is loaded incorrectly.	Make certain the label is facing upward, and then try again.
The CD is scratched or dirty.	Try cleaning the CD with a lint-free cloth. Check the CD for scratches.
The CD-ROM drive needs to be added as new hardware.	From the Control Panel window (Start Settings Control Panel), double-click Add New Hardware . Follow the directions for adding the drive. If you are not experienced with this procedure, call Technical Support.
The secondary IDE device may be disabled.	Restart your computer, and then press F2 to enter the setup program. From the Peripheral Configuration Advanced menu, set the Secondary IDE Interface to Auto and make certain the Secondary IDE Status is Enabled .
The CD cables are not installed correctly.	Open the system and check all cables between the CD controller and the CD-ROM drive.

Hard disk problems

The SCSI drive is not recognized by the system.

Probable Cause	Solution
The SCSI bus is not properly terminated.	Make certain the last device on the SCSI chain is properly terminated.
The drive is configured with a conflicting SCSI address.	Change the device SCSI address to one that is not currently used by the system.
The cables are not connected correctly.	Open the system and check the cable connections.

The IDE drive is not recognized by the system.

Probable Cause	Solution
The primary IDE device may be disabled.	Restart the server, and then press F2 to enter Setup. From the Peripheral Configuration Advanced menu, set the Primary IDE Interface and Primary IDE Status to Enabled .
The primary IDE device may be configured incorrectly.	Restart the server, and then press F2 to enter Setup. From the Main menu, set the Primary IDE Master to Auto Configured .
The drive may not be configured properly.	Consult the hard disk documentation for instructions on how to configure the drive.
The drive cables are not connected properly.	Open the system and check all cables connected to the controller card.
The drive controller is not seated properly.	Open the system and reseat the drive controller. This possibility is only valid for systems that include an add-in drive controller.

Memory/Processor problems

Memory errors were detected during system start up.

Probable Cause	Solution
Memory was added or removed, and the new configuration was not saved in BIOS Setup.	Enter BIOS Setup and save the new memory configuration.
The memory was installed incorrectly.	Check the memory for proper seating and orientation.
A DIMM is faulty.	Replace the DIMM. Third-party diagnostic programs can help determine which DIMM or memory segment is failing.

★ Important!

If the error message “update table not found for CPUxx, Stepping xxxx” displays at boot up, run the MULOADER utility located on the disk included with your processor kit. This message may occur under the following conditions: When a new processor has been added that does not include the stepping information in the table. When the BIOS is flashed, it may remove the stepping information from the table which will cause the error message to appear.

A new processor is not recognized by the system.

Probable Cause	Solution
The processor was installed incorrectly or in the wrong socket.	Check the installation. The processor should be recognized automatically if it was installed correctly.
The processor speed was not selected on the system board.	If your system board enables you to select the processor speed, make sure you have selected the speed properly.
A pin was bent on the processor during installation.	Remove the processor and inspect it for damage. If a pin is bent, very carefully try to straighten it.

Modem problems

The modem is not recognized by the system.

Probable Cause	Solution
The modem has not been added as new hardware.	Add the modem as new hardware.
The modem is not connected to a live phone jack.	Make certain the line connected to the modem is live and plugged into the appropriate port on the modem (line port).
The modem is not configured with a valid interrupt or address.	Check the system settings for possible conflicts. If one exists, correct the problem by selecting an available interrupt and address.
The phone jack is shared by another modem or telephone.	If the modem shares the jack with another device, make certain the other device does not have the port open (for instance, someone is on the phone, or another modem is in use).

Peripheral/Adapter problems

A SCSI device is not recognized by the system.

Probable Cause	Solution
The device needs to be added as new hardware.	From the Control Panel window (Start Settings Control Panel), double-click Add New Hardware . Follow the directions for adding the device. If you are not experienced with this procedure, call Technical Support.
The SCSI ID may be invalid.	Assign an available SCSI ID to the device.
The SCSI chain is not terminated.	Make certain the last device on the SCSI chain is terminated.
The device cables are not installed correctly.	Open the system and check all cables between the controller and the device.

The diskette drive is not recognized by the system.

Probable Cause	Solution
The diskette drive may be configured incorrectly.	Restart the server, and then press F2 to enter Setup. From the Main menu, ensure that the diskette drive parameters are set correctly (Legacy Diskette A or Legacy Diskette B).
The drive cables are not connected properly.	Open the system and check all cables connected to the controller.
The drive controller is not seated properly.	Open the system and reseat the drive controller. This possibility is only valid for systems that include an add-in drive controller.

The diskette drive will not read, write, or format.

Probable Cause	Solution
The diskette is not IBM formatted.	Make certain the diskette you are trying to format is IBM-compatible. If it is, try reformatting it.
The diskette is corrupted.	Run ScanDisk on the diskette. If errors are detected and corrected, try accessing the diskette again.
The diskette is write protected.	Make certain the write-protection window on the upper-right corner of the diskette is closed (unprotected).

The diskette drive LED illuminates continuously.

Probable Cause	Solution
The diskette is corrupted.	Remove the diskette from the drive. If the light remains on, try restarting the system.
The cable to the drive is not connected properly.	Open the system and check the cable between the diskette drive and its controller. Make certain the pins are not bent or misaligned.

An expansion card is not recognized by the system.

Probable Cause	Solution
The interrupt and/or I/O address is set incorrectly.	Check the address configuration of the controller card and ensure that it does not conflict with another card in the system.
The card has not been configured (e.g., EISA configuration utility).	Configure the card with the appropriate software.
The card was not installed correctly.	Reseat the card and make certain that its jumpers are configured appropriately.

Printer problems

The printer will not turn on.

Probable Cause	Solution
The printer is not plugged in.	Check the power cable. Make certain it is plugged into a live power source.
The printer is not turned on.	Make certain the printer power switch is depressed or set to the on position. If power is applied to the printer, the green power LED should light.
The printer is defective.	Try another printer if one is available.

The printer is turned on but will not print.

Probable Cause	Solution
The printer is not connected to the system.	Check the data cable between the printer and the system. Make certain it is connected to the proper port. Check the connector and cable for bent or broken pins.
The printer is not designated as the default printer.	If the printer to which you are trying to print is not the default printer, make certain you have selected it through the application's printer setup function.
The printer has not been added to the system.	From the Printers window (Start Settings Printers), double-click Add Printer . Follow the directions for adding the new printer.

The printer prints garbled text.

Probable Cause	Solution
The wrong driver is used for the selected printer.	From the Printers window (Start Settings Printers), select the printer. From the File menu, click Properties . Make certain the printer is using the right printer driver. If not, install the correct one.

System problems

The system will not start up.

Probable Cause	Solution
The system is not connected to an AC outlet.	Check the power cable(s) and make certain it is connected to an AC power source.
The voltage selection switch is not set correctly.	Make certain the voltage selection switch reflects the correct power source.
One power supply is not supplying power to the load share module.	Verify that both power cords are plugged into working AC outlets. Verify that both power cords are fully plugged into their AC-in connectors on the back panel of the computer. Verify that both power supplies are set to the correct voltage range (115-V AC or 230-V AC). Verify that both power supplies are turned on. Replace any defective power supply.

The keyboard doesn't work.

Probable Cause	Solution
A key was depressed while the system was starting up.	Clear the sticking key, then turn off the system, wait for a few seconds, and then turn the system back on.
The keyboard is not plugged in or connected properly.	Check the cable. Make certain it is plugged in correctly.
Something spilled into the keyboard.	Turn off the system. Turn the keyboard upside down to let it dry before turning the system back on.
The keyboard is defective.	Try a keyboard you know is working.

The mouse doesn't work.

Probable Cause	Solution
The mouse is not plugged in or connected properly.	Check the cable. Make certain it is plugged in correctly.
The mouse driver did not load when the system booted.	Load the appropriate mouse driver manually or contact Technical Support.
The mouse is defective.	Try a mouse you know is working.

Video problems

The system is running but there is no display.

Probable Cause	Solution
The monitor is not turned on.	Make certain the monitor is plugged in and turned on. If power is applied to the monitor, the green power LED should light.
The monitor data cable is not connected.	Make certain the monitor data cable is connected to the video controller on the back of the system.
The connector or cable is damaged.	Check the connector and cable for bent or damaged pins.
The monitor is defective.	Connect a working monitor to the computer.
The monitor brightness and contrast controls are turned down.	Adjust the brightness and contrast knobs to the center position.
The video card is not seated correctly.	Open the system and reseat the video card. This possibility is only valid for systems that include an add-in video controller.
The video card is not compatible with the system.	PCI video cards must be compatible with the system. This possibility is only valid for systems that include an add-in video controller.

The text on the display is dim or difficult to read.

Probable Cause	Solution
The monitor brightness and contrast controls are turned down.	Adjust the brightness and contrast knobs until the text becomes clear.
Sunlight is glaring off the display.	Position the monitor away from the sun or window.
The monitor may be old.	Replace the monitor.

The color monitor displays everything in black and white.

Probable Cause	Solution
The system was turned on before the monitor.	Make certain the monitor is turned on, and then restart the system.
The display type is set incorrectly.	From the Control Panel window (Start Settings Control Panel), double-click Display , set the display to the appropriate monitor type, and then reboot the system.

The displayed characters are garbled.

Probable Cause	Solution
The video cable is damaged.	Check the cable and connectors for bent pins or broken wires.
The video card has failed.	Try another video card. This possibility is only valid for systems that include an add-in video controller.
The display setup is incorrect.	From the Control Panel window (Start Settings Control Panel), double-click Display and check the settings. The correct video type should be selected, along with a supported resolution. Check your monitor and video controller documentation for details.

The video is distorted.

Probable Cause	Solution
The monitor controls are not properly adjusted.	Adjust the monitor controls until the text becomes clear. (See your monitor documentation for more information.)
The connector or cable is damaged.	Check the connector and cable for bent or damaged pins.
The surge protector or uninterruptible power supply (UPS) is damaged.	Disconnect the monitor power cable and connect it directly to the power source.
The monitor is too close to a source of electrical interference.	Move the monitor away from sources of electrical interference, such as televisions, unshielded speakers, microwaves, fluorescent lights, and metal beams or shelves.
The monitor needs to be degaussed.	Turn off the computer and monitor and leave them off for at least a half hour, and then restart the system.

Error messages

The following table lists common error messages that may be displayed on your monitor. These messages often indicate procedural errors such as an incorrect keystroke or a write-protected disk. Some messages, however, may indicate a problem that requires you to consult the troubleshooting section of this manual.

Error Message	Solutions
Access denied.	Try saving to a new file or disk. Move the write-protection tab over the hole on the back of the disk.
Bad command or file name.	Make certain you entered the right command. Verify the specified drive and try it again. If you are trying to exit MS-DOS to return to Windows, type exit and press Enter .
Base memory [xxx] expansion.	This is an informational message only. No action is required.
Checking RAM on disk controller.	Your BIOS configuration is incorrect. Enter BIOS Setup and verify the values.
CD-ROM is not recognized.	See "The CD-ROM drive is not recognized by the system." on page 88.
Data error.	Run ScanDisk on the reported disk.
Decreasing available memory.	Your BIOS configuration is incorrect. Enter BIOS Setup and verify the values.
Diskette drive is not recognized.	See "The diskette drive is not recognized by the system." on page 91.
Diskette drive 0 seek to track 0 failed.	Enter BIOS Setup and verify the diskette drive parameters. Check the diskette drive cables. Make certain pin 1 on the cable aligns with pin 1 on the connector.
Diskette drive reset failed.	Enter BIOS Setup and verify the diskette drive parameters. Check the diskette drive cables. Make certain pin 1 on the cable aligns with pin 1 on the connector.
Diskette read failed - strike F1 to retry boot.	Make certain the boot diskette contains the Command.com file. Use the configuration utility (if applicable) to verify your drive or controller configuration. Press F1 to try the boot again.

Error Message	Solutions
Gate A20 failure.	You may have an XT keyboard connected to an AT system or vice versa. Make certain the keyboard is configured to work with the appropriate system. Some keyboards have a switch to select either AT or XT.
Hard disk controller failure.	Make certain the hard disk cable is properly connected. Open the BIOS Setup program and verify that the correct drive type is selected.
Hard disk controller failure - press F1 to try reboot.	The drive controller may be defective. Press F1 to retry the boot. Try running Fdisk and DOS Format. For more information, refer to your DOS documentation.
Insert bootable media device.	See "The IDE drive is not recognized by the system." on page 89. See "The SCSI drive is not recognized by the system." on page 88. Backup your files as soon as possible.
Insufficient disk space.	Check the free space on the disk volume. If the volume is full or almost full, remove unnecessary files.
Invalid configuration information...	Enter BIOS Setup and verify the values.
Invalid password.	Enter your password again, making certain to enter it correctly. If you do not know the password, you may need to reinstall the software you are trying to access. Startup passwords are stored in BIOS. If this password has been set and is unknown, you may be able to reset the password via system board jumper settings. See "System jumpers" on page 19 for more information.
Keyboard clock line failure.	Try a working keyboard. Make certain the keyboard is compatible with the system. You may have to change the switch setting to AT. Replace the system board.
Keyboard controller failure.	Try a working keyboard. Make certain the keyboard is compatible with the system. You may have to change the switch setting to AT. Replace the system board.

Error Message	Solutions
Keyboard not detected.	See "The keyboard doesn't work." on page 94. Turn off the system and check the keyboard cable.
Keyboard stuck key failure.	Remove any objects that may be resting on the keyboard, and then restart the system. Check for sticky keys. Clean the keyboard if necessary.
Memory errors were detected while the system powered up.	See "Memory errors were detected during system start up." on page 89.
Memory size error.	Enter BIOS Setup and save the memory configuration.
Non-system disk or disk error.	Eject the diskette and press Enter . If the diskette is bootable, check it for errors.
Not enough memory.	Close all programs that are not currently in use.
Print queue is full.	Wait until the current print job has completed before sending another print job. If you receive this error often, you need to add memory to the printer.
Printer is out of paper.	Add paper to the printer. Make certain the printer is online.
Required parameter missing.	Make certain you entered the right command. If you are trying to exit MS-DOS to return to Windows, type exit and press Enter .
Syntax error.	Make certain you entered the right command. If you are trying to exit MS-DOS to return to Windows, type exit and press Enter .
Time and date not set.	Enter BIOS Setup to set the system date and time.
Write protect error.	Move the write-protection tab over the hole on the back of the diskette.



Reference Data

Acronyms and abbreviations.....	102
Terms and definitions.....	106
Specifications.....	109
Memory map.....	110
I/O map	111
IRQ usage	112
DMA usage.....	113
DIMM configurations	114
Regulatory compliance statements	116

Acronyms and abbreviations

AC - Alternating current

ACPI - Advanced Configuration & Power Interface

APIC - Advanced programmable interrupt controller

ASCII - American standard code for information interchange

ASIC - Application specific integrated circuit

ATAPI - AT advanced peripheral interface

BIOS - Basic input/output system

BIST - Basic integrity self-test

CD - Compact disc

CD-ROM - Compact disc, read-only memory

CHS - Cylinder, head, sector

CMOS - Complementary metal-oxide semiconductor

CPU - Central processing unit

DBE - Double bit errors

DIMM - Dual inline memory module

DMA - Direct memory access

DMI - Desktop management interface

DRAM - Dynamic random access memory

ECC - Error correcting code

ECP - Enhanced capabilities port

EDO - Extended data output

EMC - Electro-magnetic compatibility

EMI - Electro-magnetic interference

EPP - Expanded parallel port

ESD - Electro-static discharge

FAT - File allocation table

GB - Gigabyte

IDE - Integrated drive electronics

I/O - Input/output

IRQ - Interrupt request line

ISA - Industry standard architecture

KB - Kilobyte

LAN - Local area network

LBA - Logical block addressing

LED - Light-emitting diode

LVD - Low voltage differential

MB - Megabyte

MBE - Multiple bit error

Mbps - Megabits per second

MIDI - Musical instrument digital interface

MHz - Megahertz

MS-DOS - Microsoft disk operating system

NMI - Non-maskable interrupt

NTFS - NT file system

NVRAM - Non-volatile random-access memory

OS - Operating system

PCI - Peripheral component interconnect

PIC - Programmable interrupt controller

PIO - Paged input/output

PnP - Plug and play

POST - Power-on self-test

PS/2 - Personal System/2

RAID - Redundant array of inexpensive drives

RAM - Random-access memory

RMA - Return material authorization

ROM - Read-only memory

rpm - Revolutions per minute

RTC - Real-time clock

SBE - Single bit error

SCA - Single connector attachment

SCI - Signal control interrupt

SCSI - Small computer system interface

SDRAM - Synchronous dynamic random access memory

SE - Single-ended

SEC - Single edge contact

SMI - System management interrupt

SMM - Server management module

SMP - Symmetrical multiple processor

SVGA - Super video graphics array

TCP/IP - Transmission control protocol/Internet protocol

UPS - Uninterruptable power supply

USB - Universal serial bus

V - Volt

VAC - Volts alternating current

VGA - Video graphics array

VRM - Voltage regulator module

W - Watt

Terms and definitions

This list of terms should help you get acquainted with terms used in your computer's documentation and in your system software.

Applications - Software installed on your system. Sometimes called *programs*.

BIOS - Basic input/output system. The BIOS is software that is independent of any operating system. It enables the computer to communicate with the monitor, keyboard, and other peripheral devices without using programs on the hard disk.

The BIOS on your computer is flash BIOS, which means that it has been recorded on a memory chip that can be updated if needed.

Boot - To load the first software program (usually the operating system) that starts your computer. To perform a cold (or hard) boot, you turn the computer on when it is off. To perform a warm (or soft) boot, you reset the computer when it is already turned on.

Boot disk - A disk containing operating system programs required to start your computer. A boot disk can be a diskette, hard drive, or CD.

Byte - The basic unit of measure for computer memory. A character, such as a letter of the alphabet, uses one byte of memory. Each byte is made up of eight bits. Computer memory is often measured in kilobytes (1,024 bytes) or megabytes (1,048,576 bytes).

Cache memory - Cache is very fast memory that can be located in the processor. Cache reduces the average time required for the processor to get the data it needs from the main memory by storing recently accessed data in the cache.

CMOS memory - Complementary metal oxide semiconductor memory. CMOS memory is memory that is retained even when the computer is turned off. The Setup program settings and other parameters are maintained in CMOS memory.

Default - The option that the software or system uses when you have not made a choice yourself.

Disc - A compact disc (CD).

Disk - The device used by the computer to store and retrieve information. Disk can refer to a diskette or a hard disk.

Diskette - A removable disk, also called a floppy.

Hard drive - The drive installed inside your computer that stores all your system and data files. Depending on its configuration, the computer may have more than one hard drive. Each drive is assigned its own drive letter. If you have only one drive, its drive letter is C, and it is often called “the C drive.”

I/O - Input/output. Refers to devices, such as printers, whose purpose is to enter data into a computer or extract data from a computer. An I/O device is accessed through an I/O address: a location in memory reserved for the device to exchange information between itself and the rest of the computer.

IRQ - Interrupt request line. The IRQ is a hardware line that a device uses to signal the processor when the device needs the processor’s services. The number of IRQs is limited by industry standards.

Operating system - A program that supervises the computer’s operation, including handling I/O, networking and connectivity, and device drivers.

Path - A sequence of information that directs the system to the file it needs. For example, **c:\windows\bubbles.bmp** is the path to a graphics file on your system. The **c:** tells the system it is on the C hard drive, the **\windows** tells the system it is in the windows folder, and **bubbles.bmp** is the file.

Pixel - A pixel is an individual dot in a graphic displayed on your computer. Pixels are so close together that they look as though they are connected.

POST - Power-on self-test. POST tests your computer’s components whenever you turn on the computer.

Programs - Software installed on your system. Programs are sometimes called *applications*.

RAM - Random access memory. RAM is the computer’s system memory. You can write to and read from RAM. Information stored in RAM is temporary and is erased when the computer is turned off.

Refresh rate - The refresh rate is the rate at which the image on the monitor screen is rewritten to the screen. A fast refresh rate helps keep the image from flickering.

Resolution - The resolution is the sharpness or clarity of the image on the monitor screen. Resolution is measured by the number of pixels the screen can display. For example, a resolution of 800x600 means that the screen can display 800 pixels in a row and can display 600 rows. The more pixels displayed, the higher the resolution and the clearer the images.

ROM - Read-only memory. Permanent computer memory dedicated to a particular function. For example, the instructions for starting the computer when you first turn on power are contained in ROM. You cannot write to ROM.

Specifications

The following specifications are for the standard configuration; your system may contain optional equipment. All specifications are subject to change.

Summary	The system supports Pentium II Xeon processors running at 400 or 450 MHz. These processors fit into the slot 2 connectors on the system board. The system also supports seven expansion slots, three LVD SCA SCSI drives, onboard Ethernet, onboard SCSI controller, and a full complement of I/O ports
Dimensions	21.38"H x 9.25"W x 19.38"D, 46 lbs.
Processor	Intel Pentium II Xeon processor
Processor speed	400 or 450 MHz
Processor upgrade	Slot 2
Cache subsystem	512 KB, 1 MB, or 2 MB level-2 ECC cache
RAM	64 MB standard, 2 GB maximum
BIOS	Phoenix
IDE interfaces	Two, supporting two IDE devices each
Floppy drive	1.44-MB 3.5-inch
I/O Ports	Two serial, one parallel, two USB, one RJ-45 LAN, video, mouse, and keyboard
Mouse/Keyboard	Yes
ISA/PCI Expansion Slots	Seven PCI/ One ISA (one of the PCI slots and the ISA slot are shared)
Certification	FCC Class A, TUV, CE, CSA, and UL approved

Memory map

The following table gives descriptions of what the memory is used for at each address location.

Address (Decimal)	Address (Hexadecimal)	Size	Description
0-KB–640-KB	0000:0000–0009:FFFF	640-KB	Main memory for user applications.
640-KB–768-KB	000A:0000–000B:FFFF	128-KB	Video graphics display buffer
768-KB–896-KB	000C:0000–000D:FFFF	128-KB	Reserved for ROM on I/O adapters
896-KB–1024-KB (1-MB)	000E:0000–000F:FFFF	128-KB	System BIOS ROM
Above 1-MB			
1-MB–16-MB	0010:0000–00FF:FFFF	15-MB	Extended Memory
15-MB–16-MB	00FE:0000–00FF:FFFF	64-KB	Mapped RAM or ROM
Above 16-MB			
16MB–1024-MB (1-GB)	0100:0000–3FFF:FFFF	1-GB (minus 16-MB)	Total accessible extended memory above 16-MB
128-MB–4084-MB (4GB minus 2MB)	0800:0000–FFFD:FFFF	3966-MB	Mapped to ISA slots
4-GB minus 64KB–4-GB	FFFF:0000–FFFF:FFFF	64-KB	System BIOS ROM

I/O map

The following table gives descriptions of what the memory is used for at each address location.

Address (hex)	Size	Description
0000-000F	16 bytes	DMA-1
0020-0021	2 bytes	INT-1
0040	1 byte	Programmable interval timer 1
0041	1 byte	Refresh request counter 1
0042	1 byte	Speaker tone counter 2
0043	1 byte	Command mode register
0048	1 byte	Programmable interval timer 2
0049	1 byte	Reserved
004A	1 byte	CPU speed control counter 2
004B	1 byte	Command mode register
0061-0070	16 bytes	NMI status/registers
0080-008F	16 bytes	DMA page registers
00A0-00A1	2 bytes	INT-2
00C0-00DE	31 bytes	DMA2
0400-040F	16 bytes	DMA1
0461-0464	4 bytes	Extended NMI control
0480-048F	16 bytes	DMA high page register
04C2	1 byte	Reserved
04C6-04CE	8 bytes	DMA2
04D0-04DF	16 bytes	INT/DMA2
04E0-04FF	32 bytes	DMA

IRQ usage

The following table lists the Interrupt Request Lines (IRQs) that the system typically uses and which ones are available for use by add-on devices.

IRQ	Resource
NMI	
0	System timer
1	Keyboard
2	Cascade
3	Serial port 2 (COM2)
4	Serial port 1 (COM1)
5	Secondary parallel port (LPT2)
6	Diskette controller
7	Primary parallel port (LPT1)
8	Real time clock (RTC)
9	Cascade redirect
10	Available
11	Available
12	PS/2 mouse port
13	Math coprocessor
14	Primary hard disk
15	Secondary hard disk

DMA usage

The following table lists the direct memory access (DMA) channels that the system typically uses and which ones are available for use by expansion cards.

DMA	Resource
0	Cascade
1	Available
2	Floppy controller
3	Available
4	Redirect cascade
5	Available
6	Available
7	Available

★ **Important!**

You can use 8-MB, 16-MB, 32-MB, 64-MB, 128-MB, 256-MB, and 512-MB DIMMs in any combination, bank, or order to expand the SDRAM up to 2 GB.

DIMM configurations

Refer to the following table to configure the system random access memory (RAM).

Total Memory	DIMM Socket 1		DIMM Socket 2		DIMM Socket 3		DIMM Socket 4	
	Type	Size	Type	Size	Type	Size	Type	Size
64 MB	2 x 72	16 MB	2 x 72	16 MB	2 x 72	16 MB	2 x 72	16 MB
64 MB	4 x 72	32 MB	4 x 72	32 MB	–	–	–	–
64 MB	4 x 72	32 MB	2 x 72	16 MB	2 x x72	16 MB	–	–
64 MB	8 x 72	64 MB	–	–	–	–	–	–
96 MB	8 x 72	64 MB	4 x 72	32 MB	–	–	–	–
96 MB	8 x 72	64 MB	2 x 72	16 MB	2 x 72	16 MB	–	–
96 MB	4 x 72	32 MB	4 x 72	32 MB	2 x 72	16 MB	2 x 72	16 MB
128 MB	8 x 72	64 MB	4 x 72	32 MB	2 x 72	16 MB	2 x 72	16 MB
128 MB	8 x 72	64 MB	4 x 72	32 MB	4 x 72	32 MB	–	–
128 MB	8 x 72	64 MB	8 x 72	64 MB	–	–	–	–
128 MB	16 x 72	128 MB	–	–	–	–	–	–
192 MB	8 x 72	64 MB	8 x 72	64 MB	4 x 72	32 MB	4 x 72	32 MB
192 MB	8 x 72	64 MB	8 x 72	64 MB	8 x 72	64 MB	–	–
192 MB	16 x 72	128 MB	4 x 72	32 MB	2 x 72	16 MB	2 x 72	16 MB
192 MB	16 x 72	128 MB	4 x 72	32 MB	4 x 72	32 MB	–	–
192 MB	16 x 72	128 MB	8 x 72	64 MB	–	–	–	–
256 MB	8 x 72	64 MB	8 x 72	64 MB	8 x 72	64 MB	8 x 72	64 MB
256 MB	16 x 72	128 MB	8 x 72	64 MB	8 x 72	64 MB	–	–
256 MB	16 x 72	128 MB	16 x 72	128 MB	–	–	–	–
256 MB	32 x 72	256 MB	–	–	–	–	–	–
384 MB	16 x 72	128 MB	16 x 72	128 MB	8 x 72	64 MB	8 x 72	64 MB

Total Memory	DIMM Socket 1		DIMM Socket 2		DIMM Socket 3		DIMM Socket 4	
	Type	Size	Type	Size	Type	Size	Type	Size
384 MB	16 x 72	128 MB	16 x 72	128 MB	16 x 72	128 MB	–	–
384 MB	32 x 72	256 MB	16 x 72	128 MB	–	–	–	–
512 MB	16 x 72	128 MB	16 x 72	128 MB	16 x 72	128 MB	16 x 72	128MB
512 MB	32 x 72	256 MB	16 x 72	128 MB	8 x 72	64 MB	8 x 72	64 MB
512 MB	32 x 72	256 MB	16 x 72	128 MB	16 x 72	128 MB	–	–
512 MB	32 x 72	256 MB	32 x 72	256 MB	–	–	–	–
512 MB	64 x 72	512 MB	–	–	–	–	–	–
576 MB	64 x 72	512 MB	8 x 72	64 MB	–	–	–	–
704 MB	64 x 72	512 MB	16 x 72	128 MB	8 x 72	64 MB	–	–
960 MB	64 x 72	512 MB	32 x 72	256 MB	16 x 72	128 MB	8 x 72	64 MB
1 GB	32 x 72	256 MB	32 x 72	256 MB	32 x 72	256 MB	32 x 72	256 MB
1.5 GB	64 x 72	512 MB	64 x 72	512 MB	32 x 72	256 MB	32 x 72	256 MB
2 GB	64 x 72	512 MB	64 x 72	512 MB	64 x 72	512 MB	64 x 72	512 MB

Regulatory compliance statements

FCC Notice

This device has been tested and found to comply with the limits for a Class A digital device, pursuant to Part 15 of the FCC rules. These limits are designed to provide reasonable protection against harmful interference in a residential installation. This equipment generates, uses, and can radiate radio frequency energy and, if not installed and used in accordance with the instructions, may cause harmful interference to radio or television reception. However, there is no guarantee that interference will not occur in a particular installation. If this equipment does cause interference to radio and television reception, which can be determined by turning the equipment off and on, the user is encouraged to try to correct the interference by one or more of the following measures:

- Reorient or relocate the receiving antenna
- Increase the separation between the equipment and receiver
- Connect the equipment into an outlet on a circuit different from that to which the receiver is connected
- Consult the dealer or an experienced radio/TV technician for help

This equipment has been tested and found to comply with the limits of a Class A digital device. The accessories associated with this equipment are as follows:

- Shielded video cable
- Shielded power cord

These accessories are required to be used in order to ensure compliance with FCC rules.

Industry Canada Notice

This digital apparatus does not exceed the Class A limits for radio noise emissions from digital apparatus as set out in the radio interference regulations of Industry Canada.

Le présent appareil numérique n'émet pas de bruits radioélectriques dépassant les limites applicables aux appareils numériques de Classe A prescrites dans le règlement sur le brouillage radioélectrique édicté par Industrie Canada.

American Users



Caution!

The Federal Communications Commission warns users that changes or modifications to the unit not expressly approved by the party responsible for compliance could void the user's authority to operate the equipment.

Canadian Users:



Attention!

Couper le courant avant l'entretien.

CE Notice

This Information Technology Equipment has been tested and found to comply with the following European directives:

[i]EMC Directive 89/336/EEC amending directive 92/31/EEC & 93/68/EEC as per

-EN 5022:1995 Radiated Emission Class A
EN 55022:1995 Conducted Emission Class A

EN 50082-1:1997 according to
EN 61000-4-2:1995
EN 61000-4-3:1996
EN 61000-4-4:1988 or IEC 801-4:1998

EN 61000-4-5:1995
EN 61000-4-6:1996
EN 61000-4-8: 1993
EN 61000-4-11:1994

[ii]Low Voltage Directive (Safety) 73/23/EEC as per EN 60950: 1992, A1, A2, A3, A4 and A11.

VCCI Notice

This is a Class A product based on the standard of the Voluntary Control Council for Interference by Information Technology Equipment (VCCI). If this equipment is used in a domestic environment, radio disturbance may arise. When such trouble occurs, the user may be required to take corrective action.

この装置は、情報処理装置等電波障害自主規制協議会（VCCI）の基準に基づくクラス A 情報技術装置です。この装置を家庭環境で使用すると電波妨害を引き起こすことがあります。この場合には使用者が適切な対策を講ずるよう要求されることがあります。

European Users:



Japanese Users:



Australian and New
Zealand Users:



N-93

Australia/New Zealand Notice

This device has been tested and found to comply with the limits for a Class A digital device, pursuant to the Australian/New Zealand standard AS/NZS 3548 set out by the Spectrum Management Agency.

Caution!

Disconnect power before servicing.

Index

Numerics

32 Bit I/O, Setup utility field 66

A

abbreviations 102

acronyms 102

Adaptec 7895 16

adapter cards

installing 52

removing 54

troubleshooting 92

advanced menu, Setup screen 67

Australia/New Zealand Notice 118

B

bank configurations, DIMMs 37

Base I/O Address

Floppy Disk Controller, Setup utility field 73

Parallel Port, Setup utility field 73

Serial Port A, Setup utility field 72

Serial Port B, Setup utility field 72

battery, replacing 56

bezel

removing 5

replacing 9

BIOS

32 Bit I/O field 66

advanced menu screen 67

Base I/O Address field, Floppy Disk Controller 73

Base I/O Address field, Parallel Port 73

Base I/O Address field, Serial Port A 72

Base I/O Address field, Serial Port B 72

boot disk write protection 77

boot menu screen 78

C800-CBFF field 70

Cache Base 0-512K field 75

Cache Base 512K-640K field 75

Cache C800-CBFF field 76

Cache CC00-CFFF field 76

Cache D000-D3FF field 76

Cache D400-D7FF field 76

Cache D800-DBFF field 76

Cache DC00-DFFF field 76

Cache Extended Memory Area field 76

Cache Memory field 68

cache memory screen 75

Cache System BIOS Area field 75

Cache Video BIOS Area field 75

CC00-CFFF field 70

Cylinders field 65

D000-D3FF field 70

D400-D7FF field 70

D800-DFFF field 70

Discard Changes field 80

Diskette Access field 77

diskette controller field 73

diskette drive A field 64

diskette drive B field 64

diskette drive write protection 77

DMA Channel field, Parallel Port 73

Embedded PCI NIC field 69

Embedded PCI SCSI Channel A
 field 68
 Embedded PCI SCSI Channel B
 field 68
 Exit Discarding Changes
 field 80
 exit menu screen 80
 Exit Saving Changes field 80
 Extended Memory field 64
 Fifth Boot Device field 79
 First Boot Device field 78
 Fixed Disk Boot Sector field 77
 Floppy Disk Controller field 73
 Fourth Boot Device field 79
 hard disk drive setup screen 65
 Hard Drive field 79
 Heads field 65
 Interrupt field, Parallel Port 73
 Interrupt field, Serial Port A 72
 Interrupt field, Serial Port B 73
 IRQ Reservation
 field 69
 screen 70
 IRQ10 field 71
 IRQ11 field 71
 IRQ15 field 71
 IRQ3 field 71
 IRQ4 field 71
 IRQ5 field 71
 IRQ7 field 71
 IRQ9 field 71
 Key Click field 74
 Keyboard Auto-Repeat Delay
 field 74
 Keyboard Auto-Repeat Rate
 field 74
 Keyboard Features
 field 68
 screen 74
 Large Disk Access Mode
 field 68
 LBA Mode Control field 66
 Legacy Diskette A field 64
 Legacy Diskette B field 64
 Load Setup Defaults field 80
 main menu screen 63
 Maximum Capacity field 65
 Memory Cache field 75
 Memory Reservation
 field 69
 screen 70
 Mode field, Parallel Port 73
 Multi-Sector Transfers field 66
 Num Lock field 74
 Parallel Port field 73
 Password on Boot field 77
 Peripheral Configuration
 field 68
 screen 72
 Plug and Play O/S field 67
 Primary Master field 64
 primary master Setup screen 65
 Primary Slave field 64
 primary slave setup screen 65
 Removable Devices field 79
 Reset Configuration Data
 field 67
 Resource Configuration
 field 68
 screen 69
 Save Changes field 80
 Second Boot Device field 78
 Secondary Master field 64
 secondary master Setup
 screen 65
 Secondary Slave field 64
 secondary slave Setup screen 65
 Sectors field 65
 security menu screen 76

- Serial Port A field 72
- Serial Port B field 72
- Set Supervisor Password field 77
- Set User Password field 77
 - setup utility 62
- SHM Address field 69
- Supervisor Password field 76
- System Date field 64
- System Memory field 64
- System Time field 64
- Third Boot Device field 78
- Transfer Mode field 66
- Type field 65
- Ultra DMA Mode field 66
 - updating 81
- Use Multiprocessor
 - Specification field 67
- User Password field 76
 - boot disk, write protection 77
 - boot menu, Setup screen 78
 - bus speed, PCI 16

C

- C800-CBFF, Setup utility field 70
- cache
 - integrated 21
 - second-level 21
- Cache Base 0-512K, Setup utility field 75
- Cache Base 512K-640K, Setup utility field 75
- Cache C800-CBFF, Setup utility field 76
- Cache CC00-CFFF, Setup utility field 76
- Cache D000-D3FF, Setup utility field 76
- Cache D400-D7FF, Setup utility field 76

- Cache D800-DBFF, Setup utility field 76
- Cache DC00-DFFF, Setup utility field 76
- Cache Extended Memory Area, Setup utility field 76
- Cache Memory
 - Setup screen 75
 - Setup utility field 68
- Cache System BIOS Area, Setup utility field 75
- Cache Video BIOS Area, Setup utility field 75
- CC00-CFFF, Setup utility field 70
- CD-ROM drive
 - installing 41
 - troubleshooting 87
- CE Notice 117
 - chassis fan connectors 14
 - checklist, troubleshooting 85
 - clear CMOS jumper 34
 - closing the system 8
 - configuration
 - memory 37
 - SCSI drives 16
 - connectors
 - chassis fans 14
 - I/O 20
 - power supply 14
 - controller
 - diskette 15
 - IDE 15
 - ultraSCSI 16
- CPU
 - supported 21
 - voltage regulator modules 22
- Cylinders, Setup utility field 65

D

- D000-D3FF, Setup utility field 70

D400-D7FF, Setup utility field 70
D800-DFFF, Setup utility field 70
definitions of terms 106
dimensions 109
DIMMs
 bank configurations 37
 configurations 37
 installing 35
 removing 36
 supported 22
 troubleshooting 89
Discard Changes, Setup utility
 field 80
disk drive
 diskette controller 15
 IDE controller 15
 IDE, troubleshooting 91, 92
 installing, 5.25-inch 41
 replacing the 3.5-inch diskette
 drive 37
 ultraSCSI controller 16
Diskette Access, Setup utility
 field 77
diskette drive
 controller 15
 controller field 73
 setting drive A 64
 setting drive B 64
 troubleshooting 92
 write protection 77
DMA Channel, Parallel Port, Setup
 utility field 73
DMA usage 113

E
Embedded PCI NIC, Setup utility
 field 69
Embedded PCI SCSI
 Channel A, Setup utility field 68
 Channel B, Setup utility field 68
 error messages 98
Exit Discarding Changes, Setup
 utility field 80
exit menu, Setup screen 80
Exit Saving Changes, Setup utility
 field 80
expansion cards
 installing 52
 removing 54
 troubleshooting 92
expansion slots
 PCI 20
 PCI/ISA 20
Extended Memory, Setup utility
 field 64

F
fans, system board connectors 14
FAQ, accessing viii
FCC Notice 116
features, system board 12
Fifth Boot Device, Setup utility
 field 79
First Boot Device, Setup utility
 field 78
Fixed Disk Boot Sector, Setup utility
 field 77
flash BIOS, updating 81
Floppy Disk Controller, Setup utility
 field 73
Fourth Boot Device, Setup utility
 field 79

G
glossary, accessing on Internet viii
guidelines, troubleshooting 86

H
hard disk
 replacing 48
 setup screen 65

troubleshooting 88
Hard Drive, Setup utility field 79
Heads, Setup utility field 65
heat sink, importance 26, 30

I

IDE controller
 PCI 15
 ultra DMA 15
Industry Canada Notice 116
input/output
 connectors 20
 map 111
installing
 3.5-inch disk drive 37
 5.25-inch disk drive 41
 adapter cards 52
 battery 56
 CD-ROM drive 41
 DIMMs 35
 expansion cards 52
 hard disk 48
 memory 35
 processor 26, 30
 SDRAM memory 35
Interrupt
 Parallel Port, Setup utility field 73
 Serial Port A, Setup utility field 72
 Serial Port B, Setup utility field 73
IRQ Reservation
 Setup screen 70
 Setup utility field 69
IRQ usage 112
IRQx, Setup utility field 71

J

jumpers

clear CMOS 34
processor/bus speed 33
setting 33

K

Key Click, Setup utility field 74
Keyboard Auto-Repeat Delay, Setup utility field 74
Keyboard Auto-Repeat Rate, Setup utility field 74
Keyboard Features
 Setup screen 74
 Setup utility field 68
keyboard, troubleshooting 94
keys used in Setup 62

L

Large Disk Access Mode, Setup utility field 68
LBA Mode Control, Setup utility field 66
Legacy Diskette A, Setup utility field 64
Legacy Diskette B, Setup utility field 64
Load Setup Defaults, Setup utility field 80

M

main menu, Setup utility 63
manual conventions vi
Maximum Capacity, Setup utility field 65
memory
 configurations 37
 installing 35
 map 110
 removing DIMMs 36
 supported 22
 troubleshooting 89
Memory Cache, Setup utility

- field 75
- Memory Reservation
 - Setup screen 70
 - Setup utility field 69
- Mode, Parallel Port, Setup utility
 - field 73
- modem, troubleshooting 90
- mouse, troubleshooting 95
- Multi-Sector Transfers, Setup utility
 - field 66
- N**
- Num Lock, Setup utility field 74
- O**
- opening the system 3
- P**
- Parallel Port, Setup utility field 73
- password
 - supervisor, setting 77
 - user, setting 77
- Password on Boot, Setup utility
 - field 77
- PCI
 - bus speed 16
 - expansion slots 20
 - IDE controller 15
 - SCSI controller 16
- PCI/ISA, expansion slot 20
- Peripheral Configuration
 - Setup screen 72
 - Setup utility field 68
- peripheral devices,
 - troubleshooting 91
- Plug and Play O/S, Setup utility
 - screen 67
- power supply, connectors, system
 - board 14
- primary master drive, Setup
 - screen 65
- Primary Master, Setup utility
 - field 64
- primary slave drive, Setup screen 65
- Primary Slave, Setup utility field 64
- printer, troubleshooting 93
- processor
 - heat sink importance 26, 30
 - installing 30
 - replacing 26
 - supported 21
 - troubleshooting 89
 - voltage regulator modules 22
- processor/bus speed jumper 33
- R**
- RAM, supported 22
- regulatory compliance
 - statements 116
- Removable Devices, Setup utility
 - field 79
- removing
 - 3.5-inch disk drive 37
 - adapter card 54
 - battery 56
 - bezel 5
 - DIMMs 36
 - expansion card 54
 - hard disk 48
 - processor 26
 - side panel 3
 - terminator card 30
 - top panel 6
- replacing
 - 3.5-inch disk drive 37
 - battery 56
 - bezel 9
 - hard disk 48
 - processor 26
 - side panel 10
 - top panel 8

- Reset Configuration Data, Setup utility field 67
- Resource Configuration
 - Setup screen 69
 - Setup utility field 68
- resources
 - DMA usage 113
 - IRQ usage 112
 - memory usage 110
- S**
- safety guidelines vii
- Save Changes, Setup utility field 80
- SCAM, for Windows 95 16
- SCSI
 - automatic configuration 16
 - connectors 16
 - controller 16
 - troubleshooting 91
- SDRAM memory, installing 35
- Second Boot Device, Setup utility field 78
- secondary master drive, Setup screen 65
- Secondary Master, Setup utility field 64
- secondary slave drive, Setup screen 65
- Secondary Slave, Setup utility field 64
- Sectors, Setup utility field 65
- security
 - supervisor password 77
 - user password 77
- security menu, Setup screen 76
- Serial Port A, Setup utility field 72
- Serial Port B, Setup utility field 72
- Set Supervisor Password, Setup utility field 77
- Set User Password, Setup utility field 77
- setting jumpers 33
- Setup
 - 32 Bit I/O 66
 - advanced menu screen 67
 - Base I/O Address, Floppy Disk Controller 73
 - Base I/O Address, Parallel Port 73
 - Base I/O Address, Serial Port A 72
 - Base I/O Address, Serial Port B 72
 - BIOS utility 62
 - boot disk write protection 77
 - boot menu screen 78
 - C800-CBFF 70
 - Cache Base 0-512K 75
 - Cache Base 512K-640K 75
 - Cache C800-CBFF 76
 - Cache CC00-CFFF 76
 - Cache D000-D3FF 76
 - Cache D400-D7FF 76
 - Cache D800-DBFF 76
 - Cache DC00-DFFF 76
 - Cache Extended Memory Area 76
 - Cache Memory 68
 - cache memory screen 75
 - Cache System BIOS Area 75
 - Cache Video BIOS Area 75
 - CC00-CFFF 70
 - Cylinders 65
 - D000-D3FF 70
 - D400-D7FF 70
 - D800-DFFF 70
 - Discard Changes 80
 - Diskette Access 77
 - diskette controller 73
 - diskette drive A 64

- diskette drive B 64
- diskette drive write
 - protection 77
- DMA Channel, Parallel Port 73
- Embedded PCI NIC 69
- Embedded PCI SCSI Channel
 - A 68
- Embedded PCI SCSI Channel
 - B 68
- Exit Discarding Changes 80
- exit menu screen 80
- Exit Saving Changes 80
- Extended Memory 64
- Fifth Boot Device 79
- First Boot Device 78
- Fixed Disk Boot Sector 77
- Floppy Disk Controller 73
- Fourth Boot Device 79
- hard disk drive setup screen 65
- Hard Drive 79
- Heads 65
- Interrupt, Parallel Port 73
- Interrupt, Serial Port A 72
- Interrupt, Serial Port B 73
- IRQ Reservation 69
- IRQ reservation screen 70
- IRQ10 71
- IRQ11 71
- IRQ15 71
- IRQ3 71
- IRQ4 71
- IRQ5 71
- IRQ7 71
- IRQ9 71
- Key Click 74
- Keyboard Auto-Repeat
 - Delay 74
- Keyboard Auto-Repeat Rate 74
- Keyboard Features 68
- keyboard features screen 74
- keys used 62
- Large Disk Access Mode 68
- LBA Mode Control 66
- Legacy Diskette A 64
- Legacy Diskette B 64
- Load Setup Defaults 80
- main menu screen 63
- Maximum Capacity 65
- Memory Cache 75
- Memory Reservation 69
- memory reservation screen 70
- Mode, Parallel Port 73
- Multi-Sector Transfers 66
- Num Lock 74
- Parallel Port 73
- Password on Boot 77
- Peripheral Configuration 68
- peripheral configuration
 - screen 72
- Plug and Play O/S 67
- Primary Master 64
- primary master Setup screen 65
- Primary Slave 64
- primary slave Setup screen 65
- Removable Devices 79
- Reset Configuration Data 67
- Resource Configuration 68
- resource configuration
 - screen 69
- Save Changes 80
- Second Boot Device 78
- Secondary Master 64
- secondary master Setup
 - screen 65
- Secondary Slave 64
- secondary slave Setup screen 65
- Sectors 65
- security menu screen 76
- Serial Port A 72
- Serial Port B 72

- Set Supervisor Password 77
- Set User Password 77
- SHM Address 69
- Supervisor Password 76
- System Date 64
- System Memory 64
- System Time 64
- Third Boot Device 78
- Transfer Mode 66
- Type 65
- Ultra DMA Mode 66
- updating the BIOS 81
- Use Multiprocessor Specification 67
- User Password 76
- using 62
- SHM Address, Setup utility field 69
- side panel
 - removing 3
 - replacing 10
- single edge contact (SEC) cartridge
 - CPU 21
 - processor 21
- specifications 109
- Supervisor Password, Setup utility field 76
- supported
 - CPUs 21
 - DIMMs 22
 - memory 22
 - processors 21
 - RAM 22
- system
 - closing 8
 - DMA usage 113
 - IRQ usage 112
 - memory map 110
 - opening 3
 - specifications 109
 - troubleshooting 94
- system board
 - features 12
 - I/O connectors 20
 - illustration 12
- System Date, Setup utility field 64
- System memory, Setup utility field 64
- System Time, Setup utility field 64

T

- terminator card, removing 30
- terms defined 106
- Third Boot Device, Setup utility field 78
- top panel
 - removing 6
 - replacing 8
- Transfer Mode, Setup utility field 66
- troubleshooting
 - adapter cards 92
 - CD-ROM drive 87
 - checklist 85
 - DIMMs 89
 - error messages 98
 - expansion cards 92
 - guidelines 86
 - hard drives 88
 - IDE disk drive 91
 - IDE disk drive LED 92
 - keyboard 94
 - memory 89
 - modem 90
 - mouse 95
 - peripheral devices 91
 - printer 93
 - processor 89
 - SCSI device 91
 - system-wide problems 94
 - video 95
- Type, Setup utility field 65

U

- Ultra DMA Mode, Setup utility field 66
- ultraDMA, controller 15
- ultraSCSI, controller 16
- updating, BIOS 81
- Use Multiprocessor Specification, Setup utility field 67
- User Password, Setup utility field 76
- using
 - IRQ resources 112
 - Setup 62

V

- VCCI Notice 117
- video, troubleshooting 95
- voltage regulator modules
 - CPU 22
 - processor 22
- VRM
 - See voltage regulator module

Free Manuals Download Website

<http://myh66.com>

<http://usermanuals.us>

<http://www.somanuals.com>

<http://www.4manuals.cc>

<http://www.manual-lib.com>

<http://www.404manual.com>

<http://www.luxmanual.com>

<http://aubethermostatmanual.com>

Golf course search by state

<http://golfingnear.com>

Email search by domain

<http://emailbydomain.com>

Auto manuals search

<http://auto.somanuals.com>

TV manuals search

<http://tv.somanuals.com>