

# Unifence™ Saw Guide

## 30" Capacity

(Model 36-902)

INSTRUCTION MANUAL

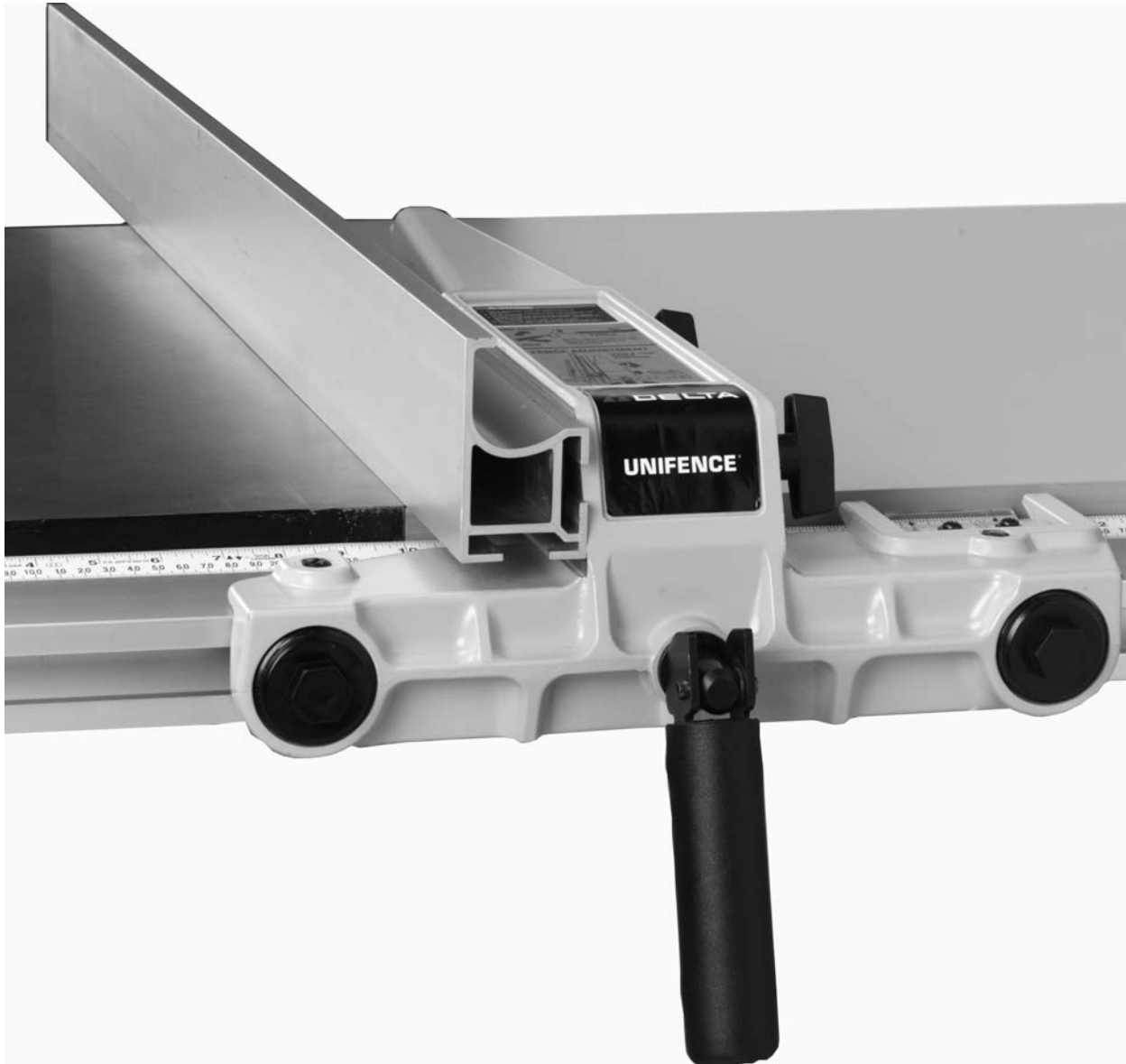

PART NO. 422-27-655-0068 - 02-14-03  
Copyright © 2003 Delta Machinery



To learn more about DELTA MACHINERY  
visit our website at: [www.deltamachinery.com](http://www.deltamachinery.com).

**For Parts, Service, Warranty or other Assistance,**

**please call 1-800-223-7278 (In Canada call 1-800-463-3582).**

# INTRODUCTION

The model 36-902, 30" capacity Unifence™ Saw Guide can be assembled to the, Contractors Saw and Unisaw, in addition to other makes of table saws. The 36-902 Unifence Saw Guide includes the fence, carriage assembly, front guide rail, table frame and legs. The accessory 36-893 table for the 36-902 30" Unifence, is not included and must be ordered separately or a similar table must be constructed by following the instructions in this manual.

## UNPACKING

Carefully unpack the Unifence and all loose items from the shipping cartons.

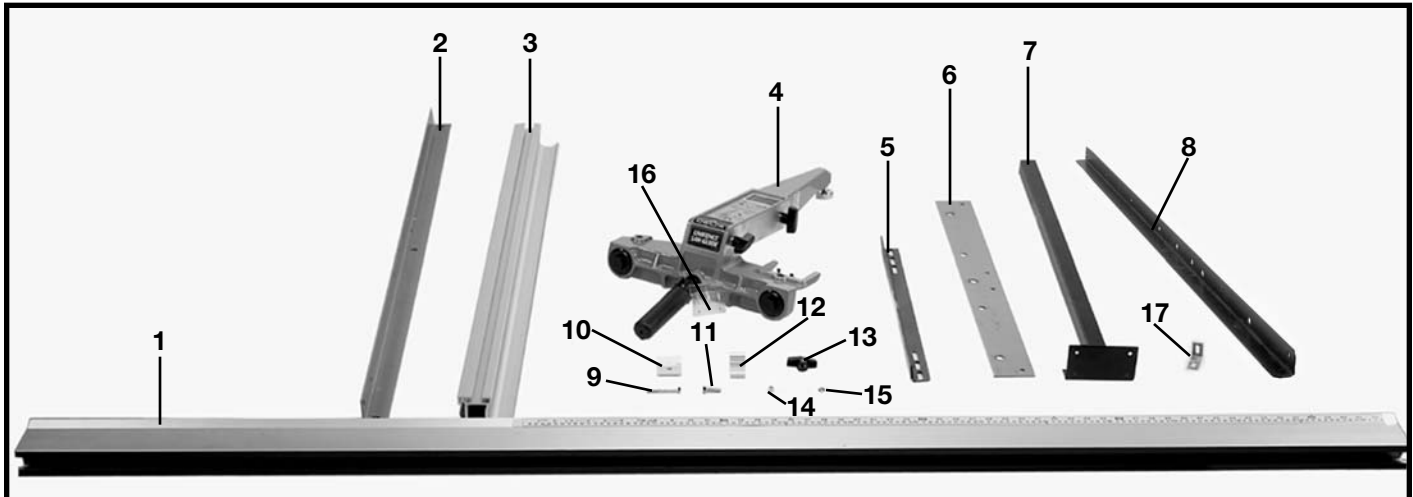
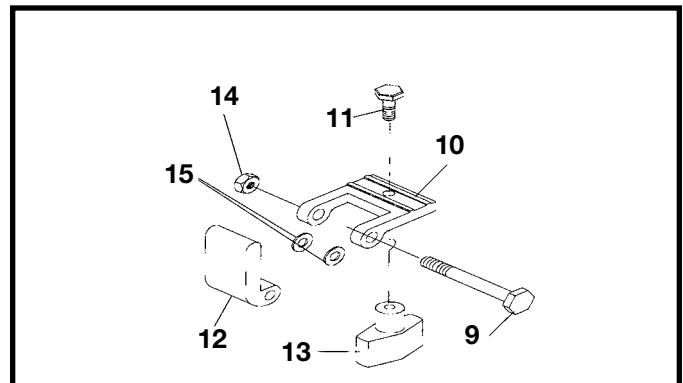

Fig. 1

1. Rail
2. Front Table Support Bracket (1)
3. Fence
4. Unifence Body
5. Table leg Support Bracket
6. Table Adapter Plate
7. Table Leg (2)
8. Rear table support bracket
9. 1/4-20x2" Flip stop bolt
10. Flip stop bracket
11. 5/16-18x1" Hex head bolt
12. Flip stop
13. Flip stop knob
14. 1/4-20 Nut
15. Flip stop fiber washer (2)
16. Unifence cursor
17. Angle bracket (5)



## CONSTRUCTING UNIFENCE TABLE AND SHELF

If you purchased the Unifence without the table, a table must be constructed, as follows:

1. A 32" long by 27" wide table is constructed using 3/4" material by following the dimensions shown in Fig. 2.
2. Three undercuts must also be made on the bottom left end of the table. The location and size of the undercuts are shown in detail in Figs. 2 and 3.
3. **IMPORTANT:** For maximum ease when sliding the fence across the table we suggest that the top of the table be covered with a veneer.



# ASSEMBLING TABLE TO SAW

1. If your saw has a right extension wing, front and rear guide rails, they must be removed.

2. Lay the table upside down on the floor or bench, as shown in Fig. 4.



Fig. 4

3. Assemble the two table legs (A) Fig. 5 to the bottom of the table using eight #8x7/8" self tapping screws supplied. **NOTE:** Refer to Fig. 2 for the hole location for the 36-902 30" Unifence.

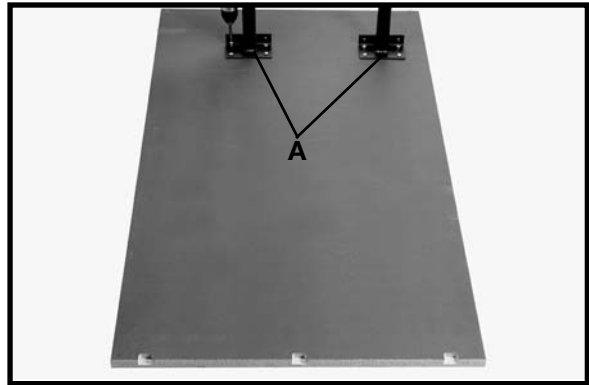

Fig. 5

4. Insert foot adapter (T) Fig. 6, into the bottom of each leg (A). Assemble the 3/8" jam nut (V) approximately 3/4 of the way onto leveling screw (W). Thread the leveling screw (W) into foot adapter. Fig. 7 illustrates the foot leveling assembly on the table leg. Assemble the remaining foot assembly to the other table leg in the same manner. **NOTE:** Height adjustments can be made later.

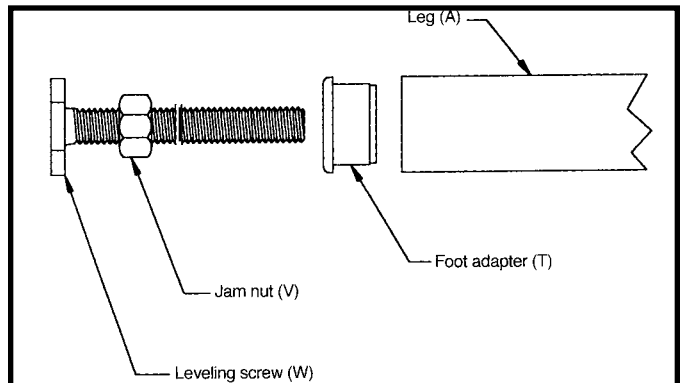

Fig. 6

4. Assemble table leg support bracket (B) Fig. 8, to the table legs (A) using two U-clamps (C), flat washers, and hex nuts.



Fig. 7

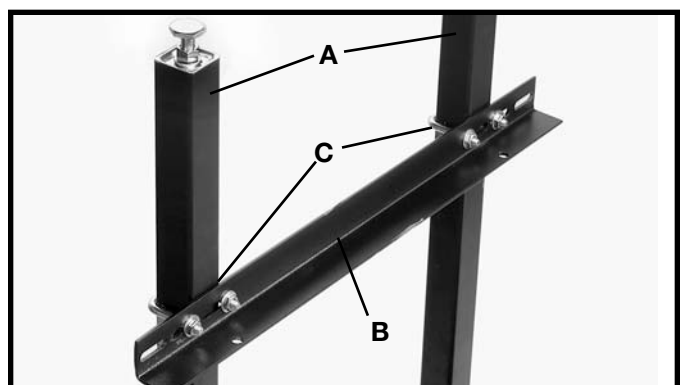

Fig. 8

5. Fasten the front table support (F) Fig. 9, to the bottom of the table as shown using two #8x7/8" long wood screws (H) and (I) supplied.

**NOTE:** The vertical flange, on the table board support (F), should be flush with the front edge of the table board.

**NOTE:** The slots closer to the angles in the support (F) should be against the table.

**NOTE:** Screws (H) and (I) Fig. 9 should not be completely tightened to the table board at this time. Screw (I) will have to be removed later.

**NOTE:** Make certain the end of the table support does not extend out past the table.

**CAUTION: DO NOT OVER-TIGHTEN MOUNTING SCREWS.** Over-tightening screws in particle board may cause them to strip.

#### **FOR UNISAWS ONLY**

6. Fasten the rear table support (A) Fig. 10, to the saw table. Insert a 3/8-24x5/8" hex head screw (B), through hole in rear support and thread screw into tapped hole in table. Repeat this process for the remaining hole. Tighten screws securely. **NOTE: FLAT EDGE (D) Fig. 10 AND FIG. 10A, OF REAR TABLE SUPPORT WILL FACE UPWARD.**

#### **FOR 10" CONTRACTORS SAWS ONLY**

6. Fasten the rear table support (A) Fig. 10, to the saw table. Insert a 3/8-16x1" hex head screw (B), through hole in rear support and table, place a 3/8 washer onto the screw and thread a 3/8-16 hex nut onto screw and tighten securely. Repeat this process for the remaining hole. **NOTE: FLAT EDGE (D) Fig. 10 AND FIG. 10A, OF REAR TABLE SUPPORT WILL FACE UPWARD.**

7. If your saw is equipped with a cast iron wing as shown at (I) Fig. 10, which has a smooth surface, hole (C) Fig. 10 is not used, proceed to **step 8**. If your saw has a sheet metal wing as shown at (W) Fig. 10A, with a ribbed surface, the rear table support will be fastened through hole (C) Fig. 10A as follows. Insert a 3/8-16x1" hex head screw through hole (C) and the sheet metal extension wing, place a 3/8" washer on the screw, thread a 3/8-16 hex nut on screw, and tighten securely.

#### **FOR ALL TABLE SAWS**

8. Assemble the three brackets (J) to the table adapter plate (K) using the three 1/4-20x3/4" carriage bolts, nuts and washers, as shown in Fig. 11. **NOTE:** The long leg of the brackets (J) should be against the adapter plate (K) as shown. Do not completely tighten brackets (J) to adapter plate (K) at this time.

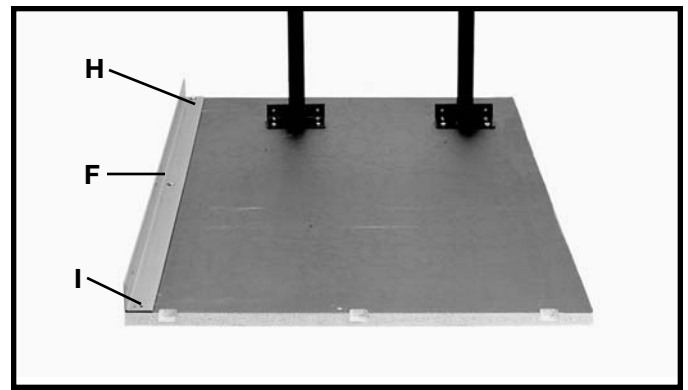

Fig. 9

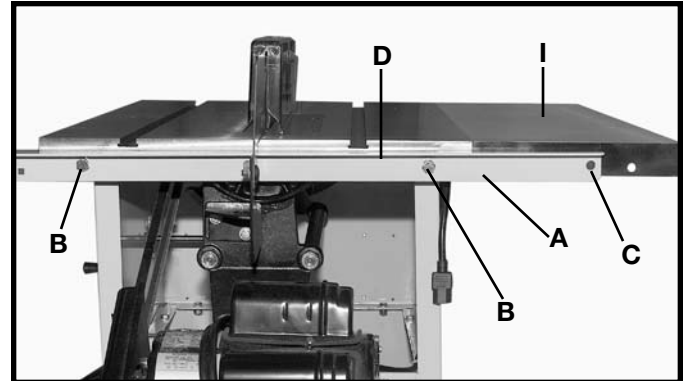

Fig. 10

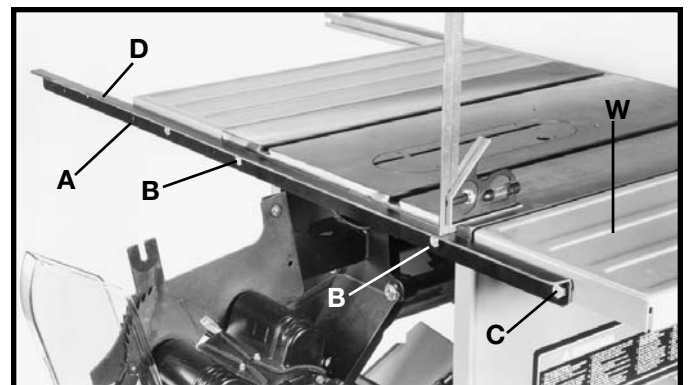

Fig. 10A

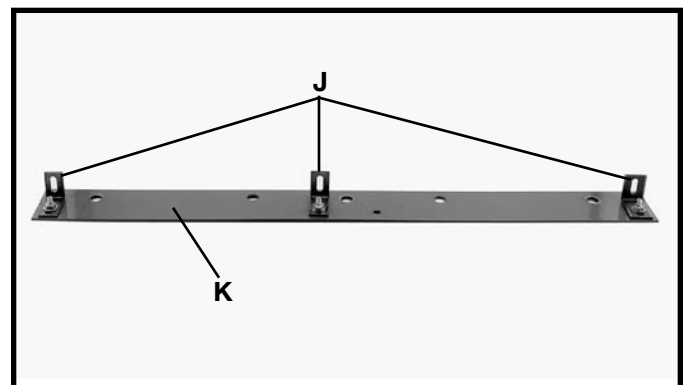

Fig. 11

### **FOR DELTA TABLE SAWS ONLY**

9. Fasten the table adapter plate (B) to the right side of the saw table. Place a 7/16" lockwasher onto a 7/16-20x1" hex head screw (D), insert screw through the table adapter plate and thread screw into right side of saw table. Repeat this process for the two remaining holes. **NOTE:** Before tightening screws (D), use a straight edge to make sure top of the adapter plate (B) is level with or slightly below surface of the saw table. Also make sure that the front edge of the adapter (B) does not stick out past the front edge of the saw table.

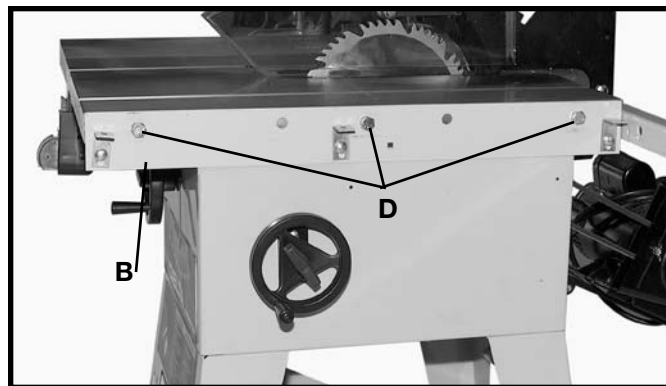

Fig. 12

### **FOR TABLE SAWS OTHER THAN DELTA**

9. Assemble table adapter plate (B) Fig. 12, to the right side of the saw table as shown using three 3/4 inch screws, lockwashers and hex nuts (not supplied). **IMPORTANT:** If the pre-drilled holes in adapter plate do not line up with the holes in the saw table, new holes must be drilled in adapter plate (B) and/or saw table. **NOTE:** Do not drill any hole to fasten adapter plate (B) Fig. 12, to the saw table that will be located less than two inches from either end of the adapter plate. Before tightening three screws (D) Fig. 12, place a straight edge (E) on the saw table and make certain the top of adapter plate is level with or slightly below the surface of the saw table. Also, make certain front of adapter plate (B) Fig. 12, does not extend out past the front edge of the saw table.

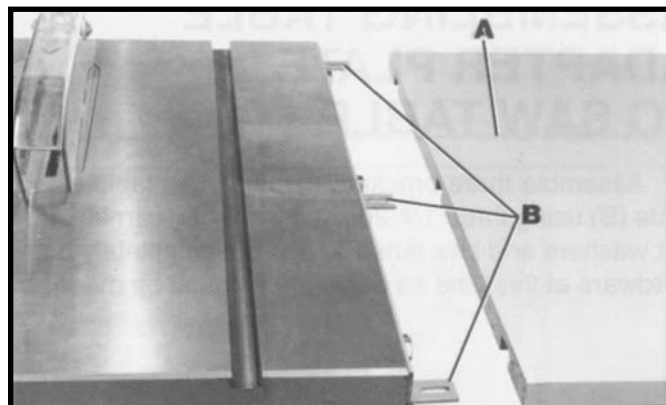

Fig. 13

### **FOR ALL TABLE SAWS**

10. Assemble the table (A) to the three brackets (B) Fig. 13, using three #8x7/8" screws (I), (E), and (F), Fig. 14. **NOTE:** Screw (I) Fig. 9, must be removed in order to attach the left side table bracket to the table. **NOTE:** The two screws (E) and (F), Fig. 14, can be tightened and screw (I) Fig. 14, should be left slightly loose at this time.

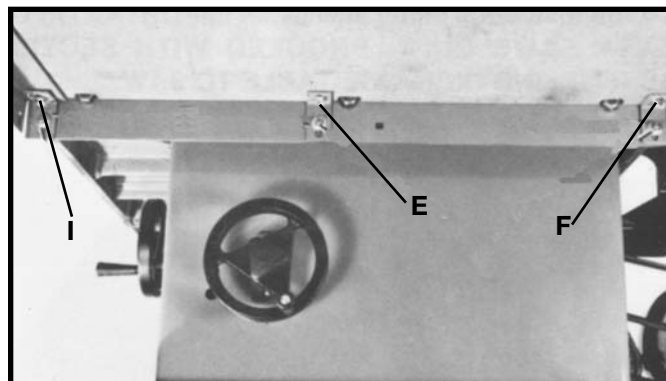

Fig. 14

11. Assemble the two brackets (J) to the rear table support (K) using the two 1/4-20x3/4" carriage bolts, nuts and washers (L), as shown in Fig. 15. **NOTE:** The long leg of the brackets (J) should be against the bottom of the table (M) as shown.

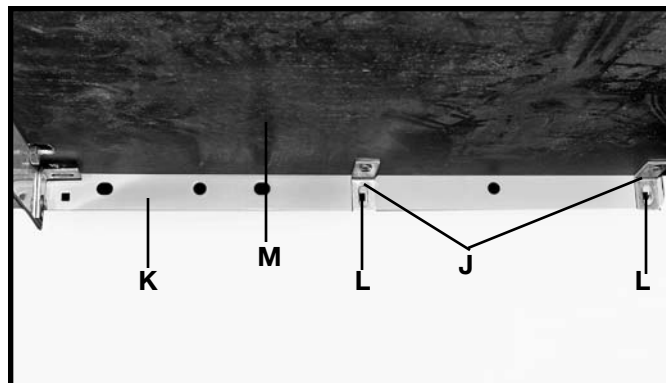

Fig. 15

12. Assemble the table (A) to the two brackets (J) on the rear table support (K) Fig. 16, using two #8x7/8" screws.

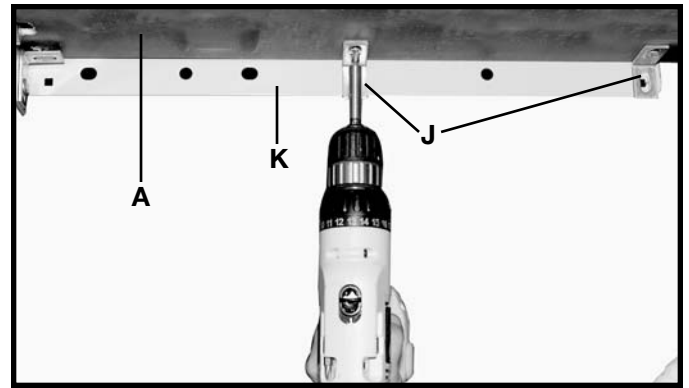

Fig. 16

13. Using a straight edge (S) Fig. 17, make certain the Unifence table surface is level with the saw table by adjusting two leveling screws located on the bottom of table legs and adjusting angle brackets (B) Fig. 13, use a level, side to side and front to back to make sure the table is level. **IMPORTANT:** Front edge of Unifence table must be flush with or slightly behind front edge of saw table.

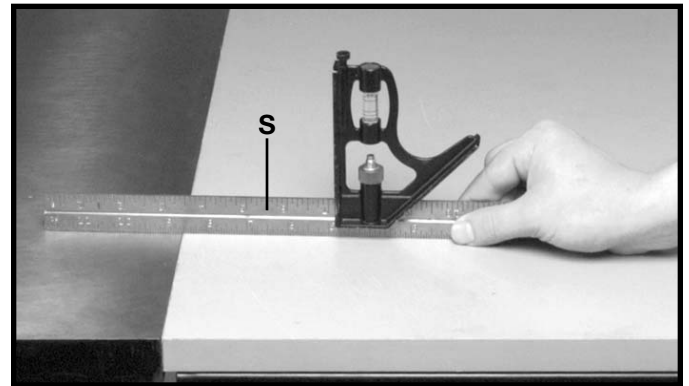

Fig. 17

## ASSEMBLING UNIFENCE GUIDE RAIL TO A SAW WITH A LEFT SIDE SHEET METAL EXTENSION WING

When mounting a 36-902 Unifence to a saw with a left side sheet metal wing, if the ON/OFF switch is mounted to the extension wing proceed with step #1 if not proceed to step #2.

1. Remove the screw (A) Fig. 18 that attaches the ON/OFF switch to the sheet metal wing. Insert a 3/8-16x1¼" hex head screw through the sheet metal wing and the ON/OFF switch bracket and place a 3/8" washer onto the screw, and thread a 3/8-16 hex nut onto the bolt, do not tighten the nut at this time. **NOTE: LEAVE THE HEX HEAD BOLT EXTENDED OUT THE FRONT OF THE SHEET METAL WING, THE GUIDE RAIL WILL BE ATTACHED TO THE END OF THE HEX HEAD SCREW.**

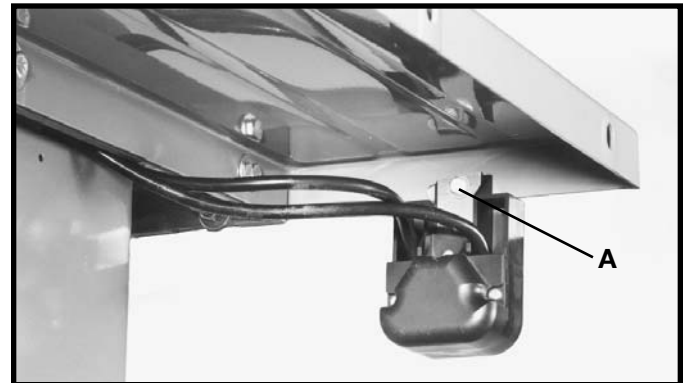

Fig. 18

2. Insert a 3/8-16x1¼" hex head screw (A) Fig. 19 through the sheet metal wing and place a 3/8" washer onto the screw, and thread a 3/8-16 hex nut onto the bolt, do not tighten the nut at this time. **NOTE: LEAVE THE HEX HEAD BOLT EXTENDED OUT THE FRONT OF THE SHEET METAL WING, THE GUIDE RAIL WILL BE ATTACHED TO THE END OF THE HEX HEAD SCREW.**

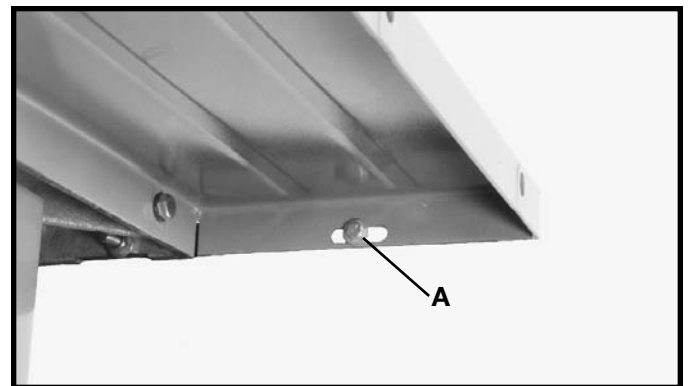

Fig. 19

# ASSEMBLING UNIFENCE GUIDE RAIL TO TABLE

1. Locate the Guide Rail and mounting hardware from the packing material of the Unifence.

2. The guide rail has end caps inserted into each end of the rail. Remove the right end cap (B) Fig. 20, by inserting a flathead screwdriver (C) into the channel in front of the guide rail and press outward against the inside of the end cap (B) as shown. The end cap (B) will pop out. **NOTE:** Do not attempt to remove the end cap by forcing the screwdriver between the end cap and the end of the rail. This will damage both the cap and the rail.

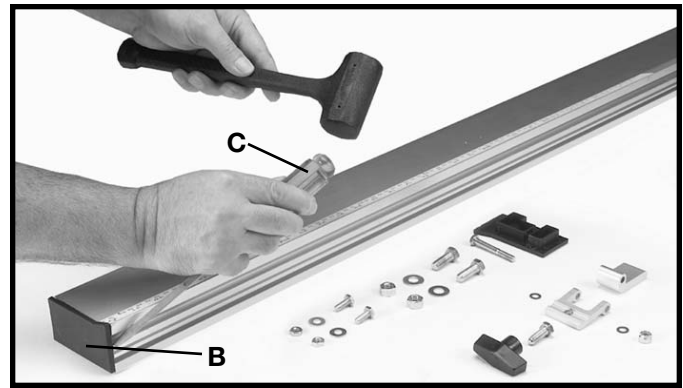

Fig. 20

## FOR DELTA TABLE SAWS ONLY

3. Insert two 3/8-24x1" hex head bolts into the two holes (F) Fig. 21, in the front of saw table and place flat washer and nut onto bolt from underneath the saw table. Screw bolts into nuts two full turns, leaving bolt head extended approximately 1/2" from the table.



Fig. 21

## FOR TABLE SAWS OTHER THAN DELTA

3. Drill two 7/16" holes in the front of the table 1.18" from the top of the table and approximately 2" in from the right and left side of the table. Insert two 3/8-24x1" hex head bolts into the two holes (F) Fig. 21, in the front of saw table and place flat washer and nut onto bolt from underneath the saw table. Screw bolts into nuts two full turns, leaving bolt head extended approximately 1/2" from the table.



Fig. 22

## FOR ALL TABLE SAWS

4. Insert one 1/4-20x3/4" hex head bolt (E) Fig. 22 into the front support of the extension table and place flat washer and nut onto bolt from underneath the extension table. Screw bolt into nut two complete turns, leaving bolt head extended approximately 1/4" from the extension table.

5. From either end, slide the T-Slot guide rail (A) Fig. 23, onto the hex head of the bolts partially inserted in step 3 and 4 above. **Note: The bolt heads on the saw table slide into the upper t-slot (B) Fig. 23 and the bolt head on the extension table slide into the lower t-slot (C) Fig. 24.**

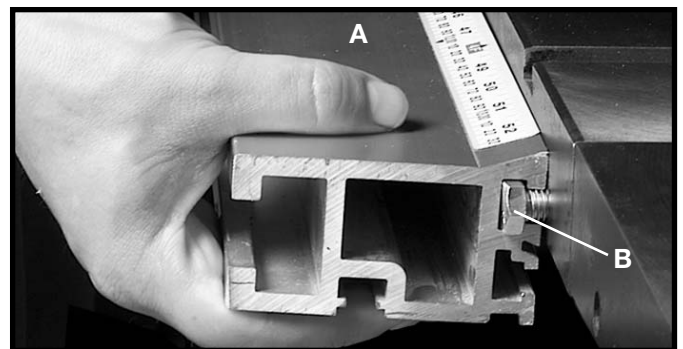

Fig. 23

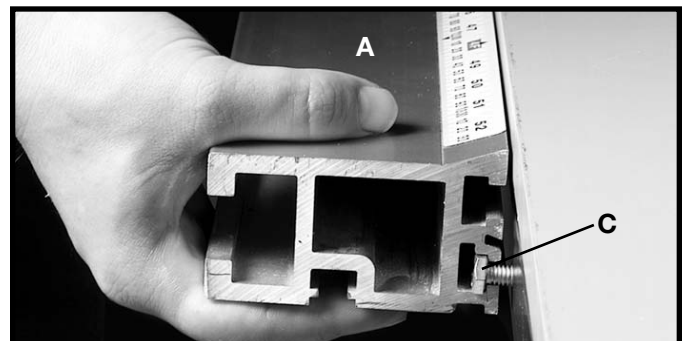

Fig. 24



6. Slide the guide rail along until the "0" on the Unifence scale is aligned with the right edge of the saw table. Snug the hex nuts on the saw and extension table but do not tighten at this time.

7. Adjust the guide rail (C) Fig. 25, parallel with the saw table surface. Place a square (H) on the saw table at both the left and right front ends of the table, with the rule of the square against the flat surface on top of the guide rail. The guide rail (C) Fig. 25, can be adjusted up or down at either end. After you are certain the guide rail is parallel with the table surface, firmly tighten the two hex nuts that fasten the guide rail to the table. **NOTE: If a bolt was inserted through a sheet metal extension wing on the left side of the saw, tighten that nut also.**

8. Move the square (H) Fig. 26, to the end of the Unifence table and check to make certain the same distance is maintained from the top surface of the extension table (K) to the top surface of the guide rail (C). Move the front table support (L) Fig. 27, against the guide rail (C), and tighten the 1/4-20 nut (M). Tighten two wood screws, one of which is shown at (N) Fig. 27, that fasten the Unifence table to the guide rail.

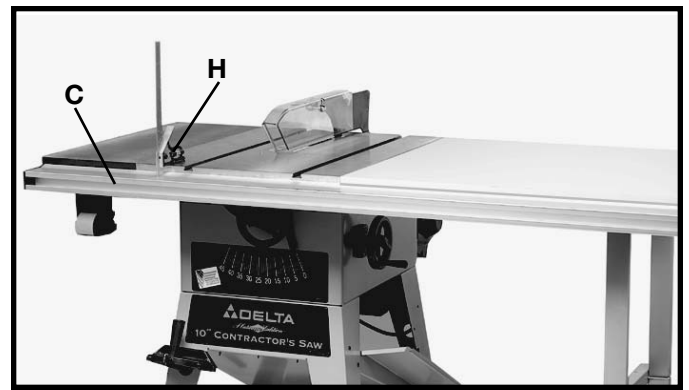

Fig. 25

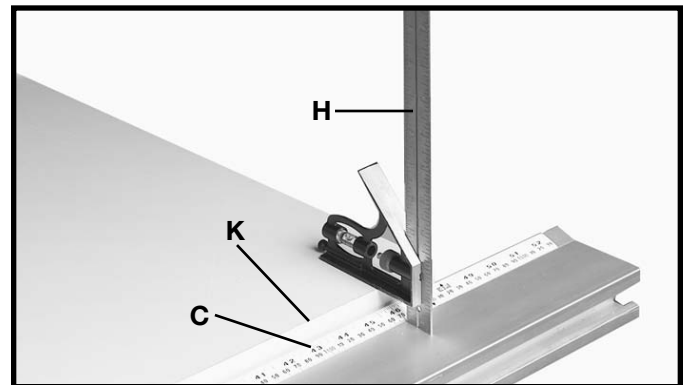

Fig. 26

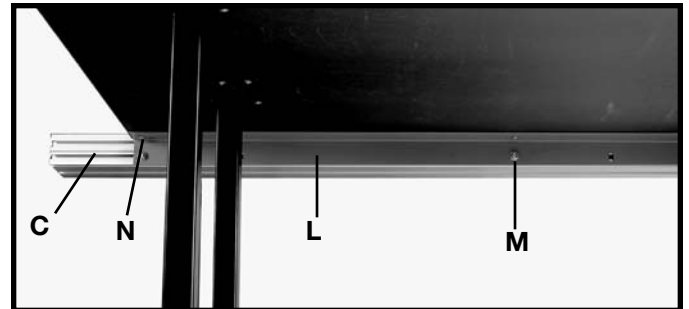

Fig. 27

## ASSEMBLING RAIL STOP

1. Insert 1/4-20x2" bolt (A) through hole into one side of bracket (B) Fig. 28.

2. Place one washer (C), on bolt (A), and slide bolt through flip stop (D) Fig. 28.

3. Place the other washer (C), on bolt (A), and slide bolt (A) through other side of bracket (B) Fig. 28.

4. Screw nut (E) onto bolt (A) and tighten.

5. Insert bolt (F) through bracket (B) as shown and screw knob (G) onto bolt (F) approximately 3 complete turns. Fig. 28.

6. Attach rail stop to unifence as shown in Fig. 30.

7. Using a rubber mallet (P) Fig. 29, or a hammer and a block of wood, gently tap end cap (R) into both ends of the guide rail. **NOTE: To avoid damage to the guide rail, DO NOT use a metal hammer directly against the guide rail.**

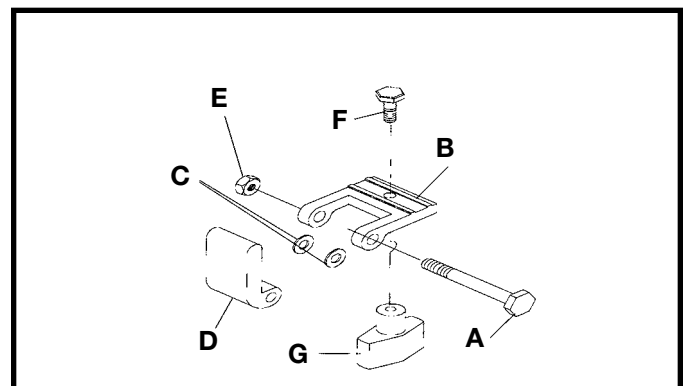

Fig. 28

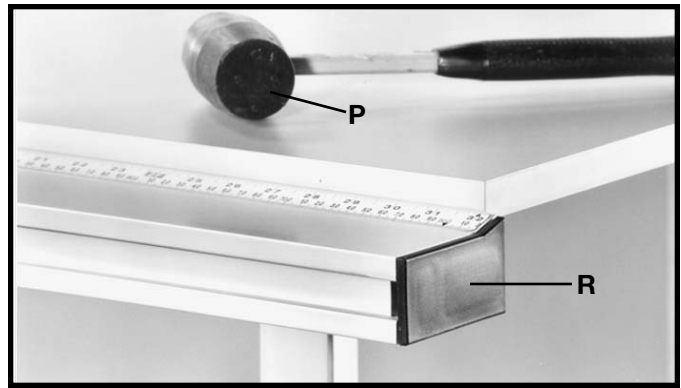

Fig. 29

## ADJUSTING RAIL STOP

1. The Rail Stop Assembly Fig. 30, can be adjusted to any number of positions along the guide rail providing a quick stop setting for the Unifence body by loosening knob (G) and sliding the stop along the rail to the desired position and re-tighten.
2. Any number of stops can be purchased and installed to provide time saving quick stop adjustment for the Unifence body.
3. If flip stop does not retract fully the bolt (F) Fig. 30, may have to be repositioned in the rail slot to allow the flip stop to retract fully. If bolt (F) needs to be repositioned, just slide the bolt out of the rail and turn the head of the bolt one third of a turn (one flat) and slide back into rail, repeat this until the bolt is in the right position for the flip stop to retract fully. Fig. 31.

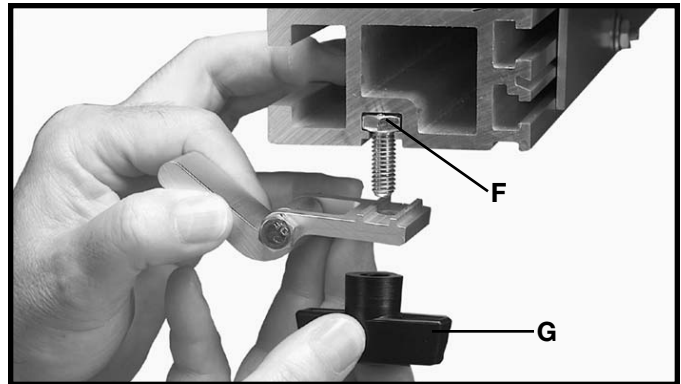

Fig. 30



Fig. 31

## ASSEMBLING CURSOR TO UNIFENCE BODY

1. Remove two screws and flat washers (A) Fig. 32, and assemble the cursor (B) to the Unifence body (C). Replace the two screws and flat washers (A).
2. Fig. 33 illustrates the cursor (B) assembled to the Unifence body. Adjustment to the cursor (B) will be made later.

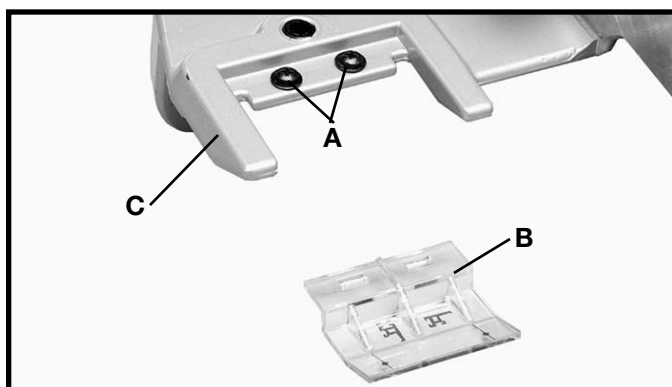

Fig. 32

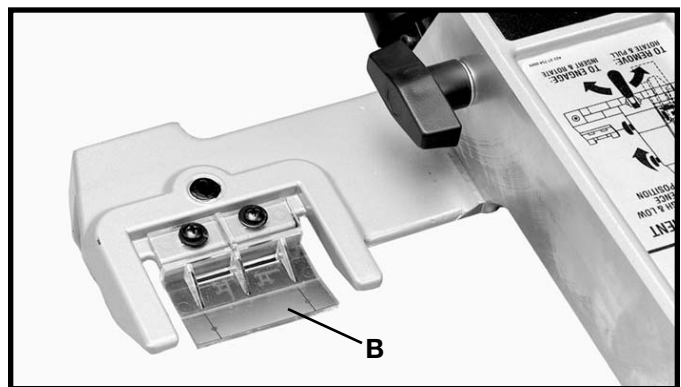

Fig. 33

# ASSEMBLING UNIFENCE BODY TO GUIDE RAIL

1. Turn fence body (A) Fig. 34, upside down and lay it on a table or bench. Push handle (B) in against fence body. Make certain the surface (C) of clamp bracket is parallel to the face (D) of the fence body, and that the inside edge (E) of the clamp bracket is parallel to surface (F) of the fence body. Turn handle (B) Fig. 32, if necessary.

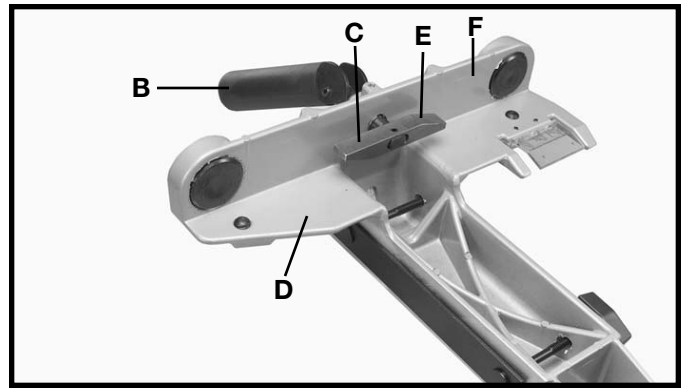

Fig. 34

2. Place fence body (A) Fig. 35, onto the guide rail as shown, making sure clamp bracket is inserted into channel (G) on rail. Notice that the clamp handle (B) is turned to the left indent position.

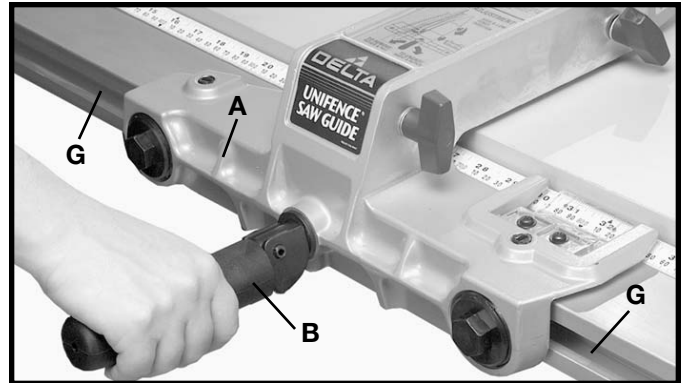

Fig. 35

3. While pushing in on handle, turn to the right indent position as shown in Fig. 36. This will prevent fence clamp from sliding out of the channel (G).

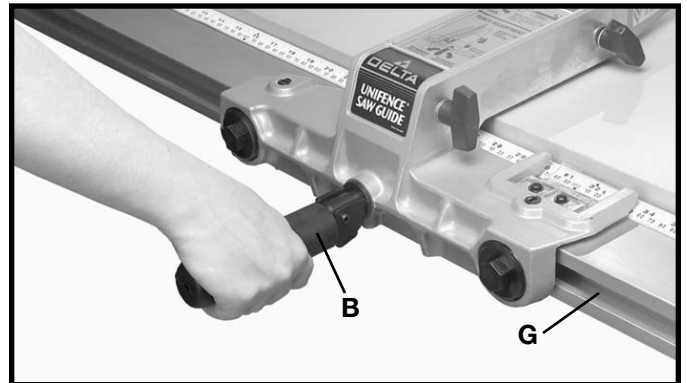

Fig. 36

4. Lock fence body (A) to the guide rail by pushing down on handle (B) as shown in Fig. 37.

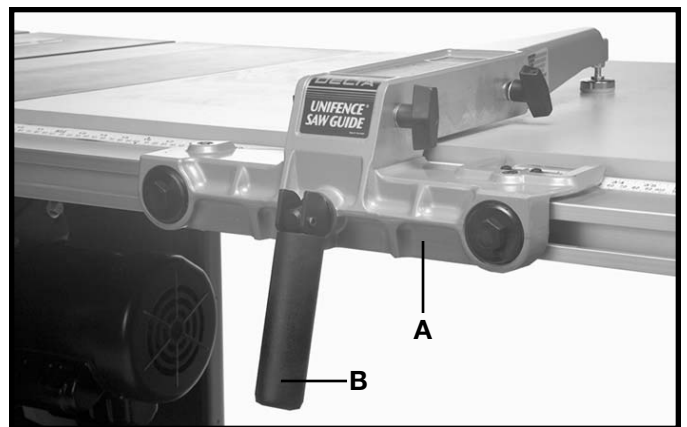

Fig. 37

# ASSEMBLING FENCE TO UNIFENCE BODY

1. The fence (A) can be assembled to clamp plate (B) in either the horizontal position as shown in Fig. 38, or the vertical position as shown in Fig. 39. Make certain the two lock knobs (C), are loose and slide fence (A) onto clamp plate (B) as shown. Then tighten the two lock knobs (C).

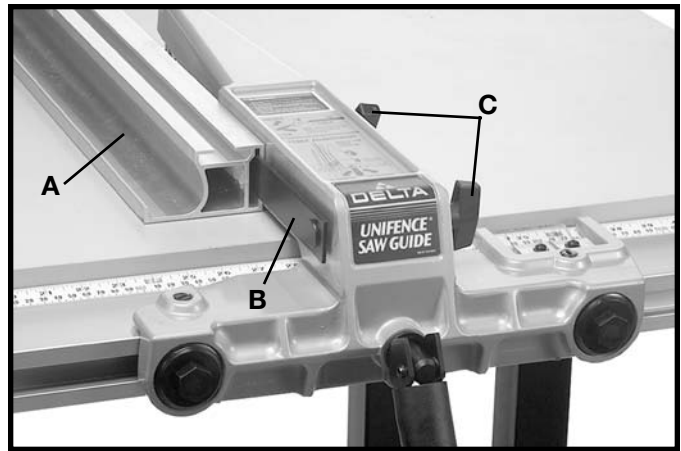

Fig. 38

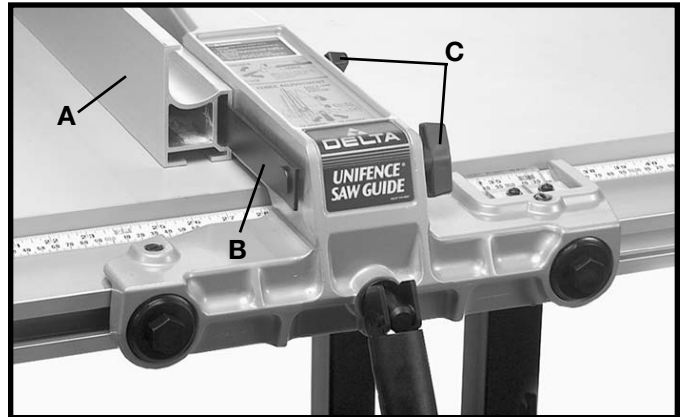

Fig. 39

2. For most normal ripping operations, the bottom of the fence should be positioned slightly above the table surface. Loosen two lock knobs (C) Fig. 40, and place a thin object such as a scale (D) between the table and fence, as shown. Then tighten two lock knobs (C).

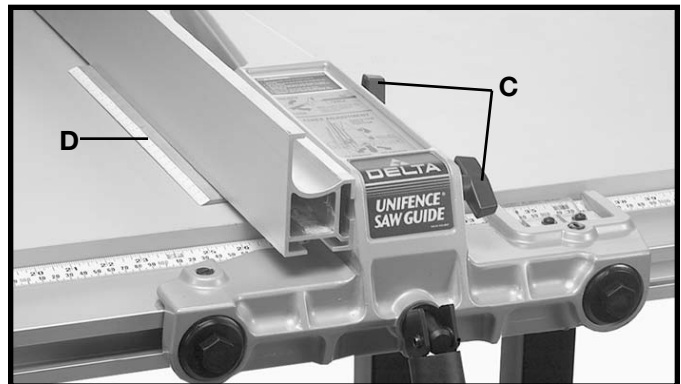

Fig. 40

# FENCE OPERATION

1. Before operating fence, make sure the fence is adjusted parallel to miter gage slot, as explained later on in this manual.

2. For most normal ripping operations of standard size lumber, the fence is used in the vertical position, as shown in Fig. 41.



Fig. 41

3. When ripping thin stock, it is sometimes more convenient to use the fence in the horizontal position, as shown in Fig. 42.



Fig. 42

4. To move the fence along the guide rail, lift up clamp lever (A), as shown in Fig. 43, slide fence to desired position on the rail, and push down on clamp lever (A) to lock fence in place.



Fig. 43

5. The distance the fence is positioned away from the blade is indicated by the two witness lines (B) and (C) Fig. 44, located on the cursor (D). Witness line (B) indicates the distance the fence is away from the blade when the fence is in the horizontal position, and witness line (C) indicates the distance the fence is away from the blade when the fence is in the vertical position. If it is necessary to adjust cursor (D), make a test cut with the fence in either the vertical or horizontal position, measure the distance of the finished cut and move the cursor (D) by loosening the two screws (E) Fig. 44. After adjustment is completed tighten the two screws (E).

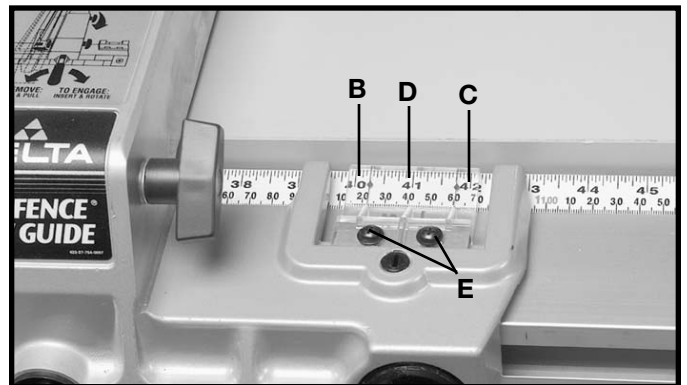

Fig. 44

6. To remove the fence and fence body assembly (F) Fig. 45, from the guide rail, lift up on fence clamping lever (A) and turn lever (A) counterclockwise to the left indent position. The fence assembly (F) can then be pulled straight off the guide rail and removed.

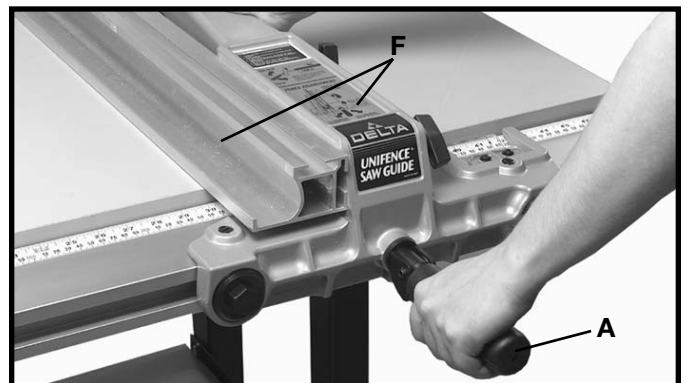

Fig. 45

# RIPPING WITH THE UNIFENCE

Ripping is the operation of making a lengthwise cut through a board, as shown in Fig. 46, and the rip fence (A) is used to position and guide the work. One edge of the work rides against the rip fence while the flat side of the board rests on the table. Since the work is pushed along the fence, it must have a straight edge and make solid contact with the table. The saw blade guard must be used. On Delta saws, the guard has anti-kickback fingers to prevent kickback and a splitter to prevent the saw from closing and binding the blade.

Never stand in the line of the saw cut when ripping. Hold the work with both hands and push it along the fence and into the saw blade as shown in Fig. 46. The work can then be fed through the saw blade with one or two hands. After the work is beyond the saw blade and anti-kickback fingers, the hand is removed from the work. When this is done the work will either stay on the table, tilt up slightly and be caught by the end of the rear guard or slide off the table to the floor. Alternately, the feed can continue to the end of the table, after which the work is lifted and brought along the outside edge of the fence. The cut-off stock remains on the table and is not touched with the hands until the saw blade is stopped, unless it is a large piece allowing safe removal. When ripping boards longer than three feet, it is recommended that a work support be used at the rear of the saw to keep the workpiece from falling off the saw table.

If the ripped work is less than 4 inches wide, a push stick should always be used to complete the feed, as shown in Fig. 47. When ripping stock 2 inches or narrower, assemble an auxiliary wood facing to the fence, as explained in the section **“USING AUXILIARY WOOD FACING ON THE UNIFENCE”** and use a push stick.

When ripping material with a veneer facing that extends over the material, the fence (A) should be in the horizontal position with the veneer (B) extending over the lip of the fence, as shown in Fig. 48.

When ripping material with a veneer facing and the material is not thick enough for the veneer to extend over the lip of the fence or if the veneer facing (B) is on both sides of the material, as shown in Fig. 49, the fence can be positioned slightly above the surface of the table. The veneer can be placed between the fence and the table or the veneer can straddle the fence with the material solidly against the fence.

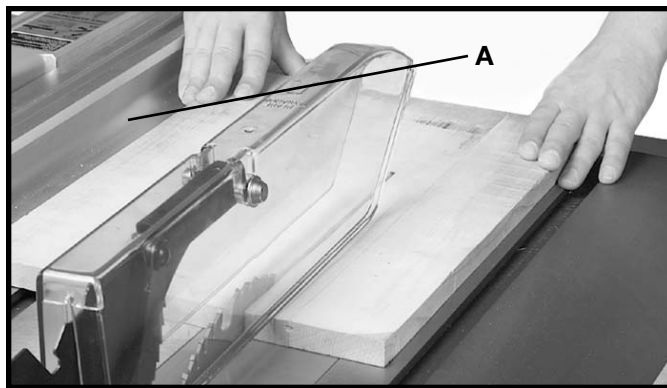

Fig. 46



Fig. 47

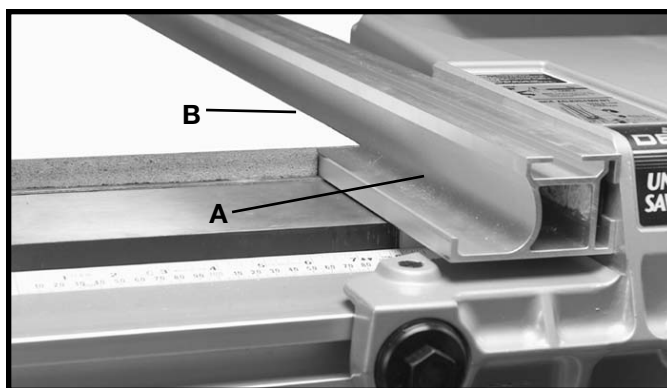

Fig. 48

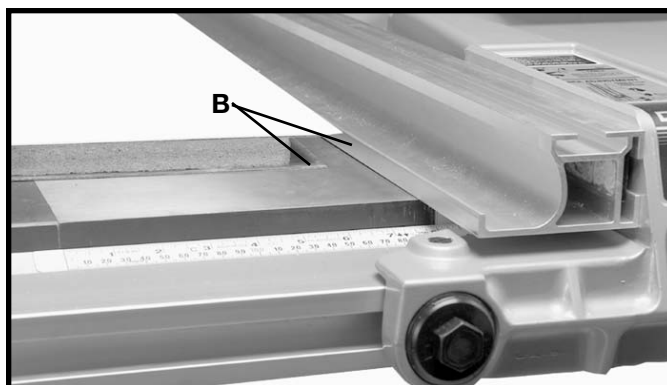

Fig. 49

## ADJUSTING FENCE PARALLEL TO MITER GAGE SLOTS

The fence (A) Fig. 50, should be adjusted so it is parallel to miter gage slots (B). To check and adjust, move the fence (A) until the bottom front edge of the fence is in line with the edge of the miter gage slot as shown, and push down on fence clamping lever (C). Check to see if the fence is parallel to the miter gage slot the entire length of the table. If the rear of the fence must be moved, slightly tighten or loosen one of the adjustment plugs (D) or (E) Fig. 50, using the arbor wrench or a 7/8" wrench, until the fence is parallel with the miter gage slot. **IMPORTANT: DO NOT OVER-TIGHTEN PLUGS (D) AND (E) FIG. 50. VERY LITTLE MOVEMENT OF THESE PLUGS IS NECESSARY WHEN ADJUSTING THE FENCE PARALLEL WITH THE MITER GAGE SLOT.**

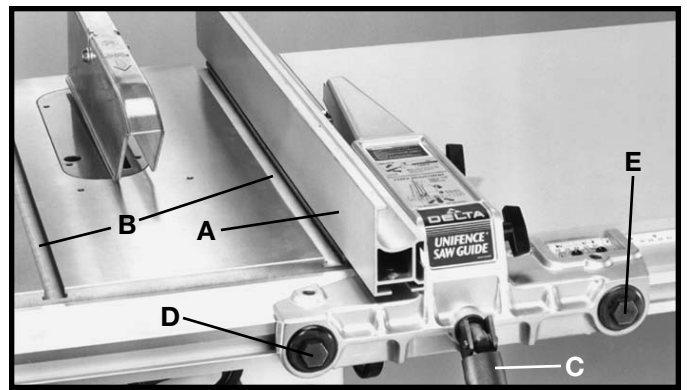

Fig. 50

## ADJUSTING FENCE 90 DEGREES TO TABLE

The fence must be adjusted so that the face of fence (A) Fig. 51, is 90 degrees to the table. To check if the fence is 90 degrees to the table, place a square (B) on the table with one end of the square against the fence, as shown. If an adjustment is necessary, tighten or loosen one of two screws (C) or (D) until the fence is 90 degrees to the table.

**IMPORTANT: VERY LITTLE MOVEMENT OF THESE SCREWS (C) AND (D) IS NECESSARY TO MAKE THIS ADJUSTMENT.**

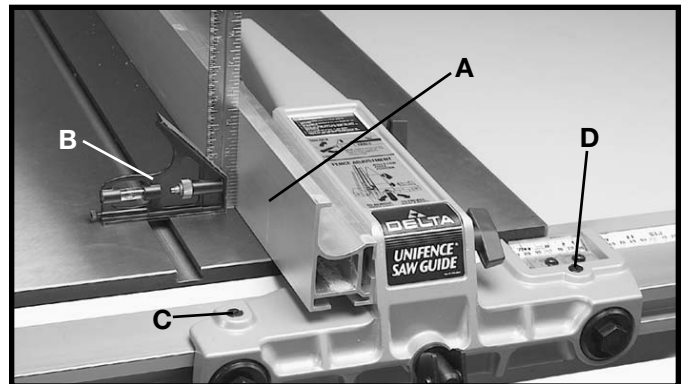

Fig. 51

## ADJUSTING CLAMPING ACTION OF FENCE LOCKING HANDLE

When the fence locking handle (A) is pushed to the down position, as shown in Fig. 52, the fence body (B) should be completely clamped to the guide rail. If the fence body (B) is not completely clamped to the guide rail when the handle (A) is in the position shown in Fig. 52, lift up on locking handle (A) Fig. 53, and slightly tighten two adjustment plugs (C) using the arbor wrench or 7/8" wrench. Adjustment plugs (C) should be tightened an equal amount. Check to see if the fence body (B) is completely fastened to the rail by pushing down on locking lever (A). Adjust further if necessary. **IMPORTANT: AFTER ADJUSTING THE CLAMPING ACTION OF THE FENCE LOCKING HANDLE, CHECK TO SEE IF THE FENCE IS PARALLEL TO THE MITER GAGE SLOT AND ADJUST IF NECESSARY.**

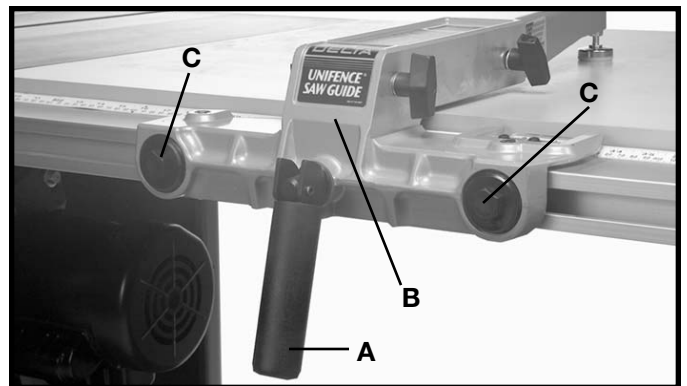

Fig. 52

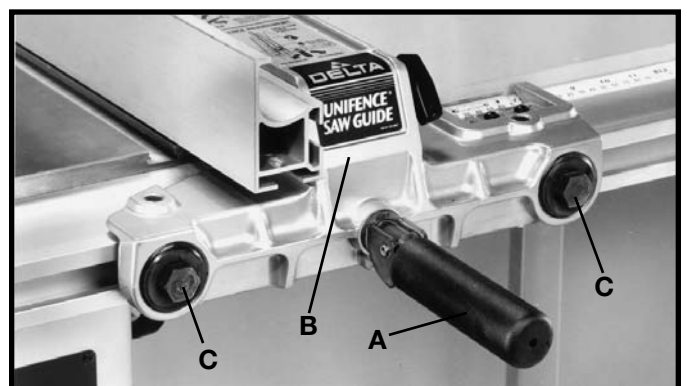

Fig. 53

## RIPPING ON LEFT SIDE OF SAW BLADE

In some cases it may be desirable to use the fence on the left side of the saw blade. This is accomplished by repositioning the fence (A) Figures 54 and 55, fence clamp bar (B) and lock knobs (C) so that the fence (A) will be attached to the right side of the fence body, as shown in Fig. 55. The complete fence assembly (D) Fig. 55, can easily be moved to the left side of the saw table.

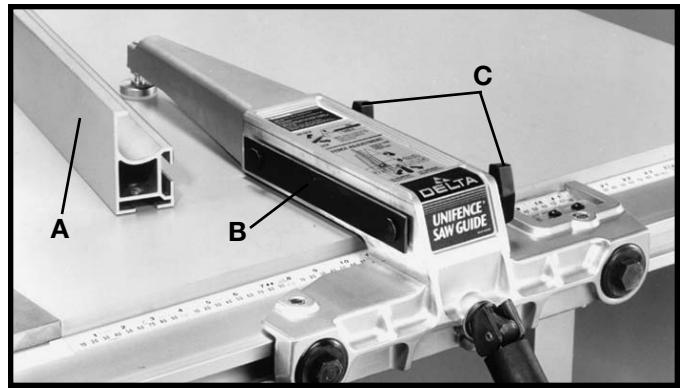

Fig. 54

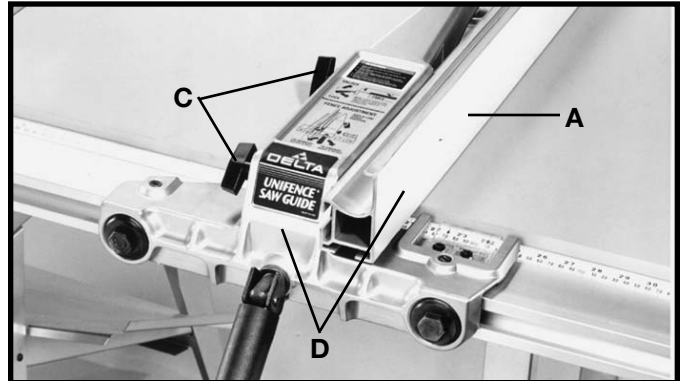

Fig. 55

## USING THE FENCE AS A CUT-OFF GAUGE

The fence can be used as a cut-off gage when cross cutting a number of pieces to the same length. **IMPORTANT:** When using the fence as a cut-off gage, it is very important that the rear end of the fence be positioned in front of the saw blade. When using the fence as a cut-off gage, simply position the fence (A) to the front as shown in Fig. 56, or purchase a 12" long fence (B) catalog # 34-878, as shown in Fig. 57. A typical operation using the 12" long fence (B) as a cut-off gage is shown in Fig. 58.



Fig. 56



Fig. 57

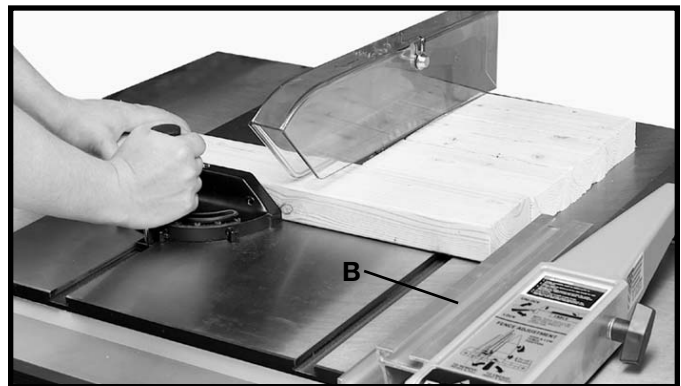

Fig. 58



## USING AUXILIARY WOOD FACING ON THE UNIFENCE

It is necessary when performing special operations such as when using the moulding cutterhead to add wood facing (A) Fig. 59, to one side of the rip fence as shown. The wood facing is attached to the fence with wood screws through holes drilled in the fence. A suitable stock size for most work is 3/4", although an occasional job may require one inch facing.

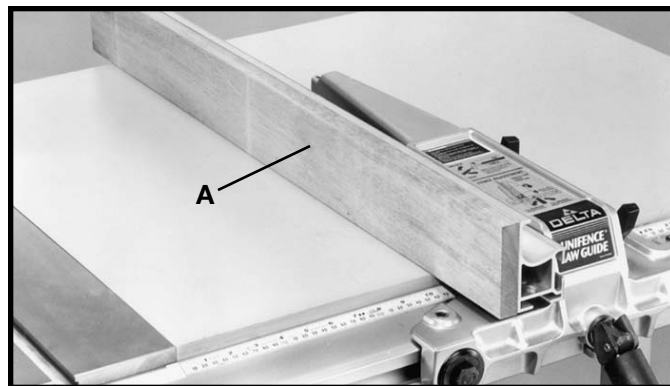
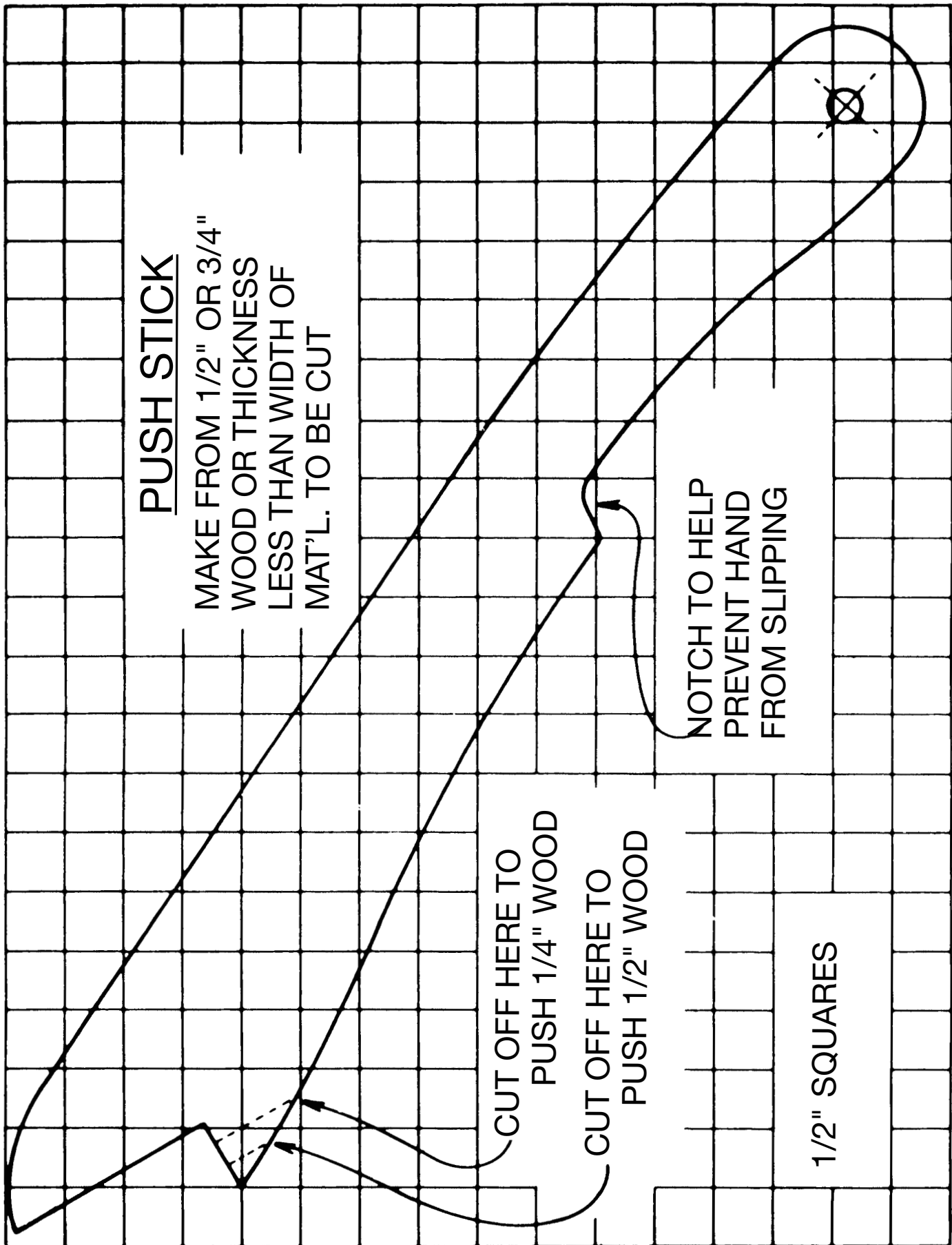

Fig. 59

# CONSTRUCTING A PUSH STICK

When ripping work less than 4 inches wide, a push stick should be used to complete the feed and could easily be made from scrap material by following the pattern shown.



# ACCESSORIES

A complete line of accessories is available from your Delta Supplier, Porter-Cable • Delta Factory Service Centers, and Delta Authorized Service Stations. Please visit our Web Site [www.deltamachinery.com](http://www.deltamachinery.com) for a catalog or for the name of your nearest supplier.

 **WARNING:** Since accessories, other than those offered by Delta, have not been tested with this product, use of such accessories could be hazardous. For safest operation, only Delta recommended accessories should be used with this product.



## PARTS, SERVICE OR WARRANTY ASSISTANCE

All Delta Machines and accessories are manufactured to high quality standards and are serviced by a network of Porter-Cable • Delta Factory Service Centers and Delta Authorized Service Stations. To obtain additional information regarding your Delta quality product or to obtain parts, service, warranty assistance, or the location of the nearest service outlet, please call 1-800-223-7278 (In Canada call 1-800-463-3582).



### Two Year Limited Warranty

Delta will repair or replace, at its expense and at its option, any Delta machine, machine part, or machine accessory which in normal use has proven to be defective in workmanship or material, provided that the customer returns the product prepaid to a Delta factory service center or authorized service station with proof of purchase of the product within two years and provides Delta with reasonable opportunity to verify the alleged defect by inspection. Delta may require that electric motors be returned prepaid to a motor manufacturer's authorized station for inspection and repair or replacement. Delta will not be responsible for any asserted defect which has resulted from normal wear, misuse, abuse or repair or alteration made or specifically authorized by anyone other than an authorized Delta service facility or representative. Under no circumstances will Delta be liable for incidental or consequential damages resulting from defective products. This warranty is Delta's sole warranty and sets forth the customer's exclusive remedy, with respect to defective products; all other warranties, express or implied, whether of merchantability, fitness for purpose, or otherwise, are expressly disclaimed by Delta.

Printed in U.S.A.

## PORTER-CABLE • DELTA SERVICE CENTERS (CENTROS DE SERVICIO DE PORTER-CABLE • DELTA)

Parts and Repair Service for Porter-Cable • Delta Machinery are Available at These Locations  
(Obtenga Refaccion de Partes o Servicio para su Herramienta en los Siguietes Centros de Porter-Cable • Delta)

### ARIZONA

Tempe 85282 (Phoenix)  
2400 West Southern Avenue  
Suite 105  
Phone: (602) 437-1200  
Fax: (602) 437-2200

### CALIFORNIA

Ontario 91761 (Los Angeles)  
3949A East Guasti Road  
Phone: (909) 390-5555  
Fax: (909) 390-5554

San Leandro 94577 (Oakland)  
3039 Teagarden Street  
Phone: (510) 357-9762  
Fax: (510) 357-7939

### COLORADO

Arvada 80003 (Denver)  
8175 Sheridan Blvd., Unit S  
Phone: (303) 487-1809  
Fax: (303) 487-1868

### FLORIDA

Davie 33314 (Miami)  
4343 South State Rd. 7 (441)  
Unit #107  
Phone: (954) 321-6635  
Fax: (954) 321-6638

Tampa 33609

4538 W. Kennedy Boulevard  
Phone: (813) 877-9585  
Fax: (813) 289-7948

### GEORGIA

Forest Park 30297 (Atlanta)  
5442 Frontage Road,  
Suite 112  
Phone: (404) 608-0006  
Fax: (404) 608-1123

### ILLINOIS

Addison 60101 (Chicago)  
400 South Rohlwing Rd.  
Phone: (630) 424-8805  
Fax: (630) 424-8895

Woodridge 60517 (Chicago)

2033 West 75th Street  
Phone: (630) 910-9200  
Fax: (630) 910-0360

### MARYLAND

Elkridge 21075 (Baltimore)  
7397-102 Washington Blvd.  
Phone: (410) 799-9394  
Fax: (410) 799-9398

### MASSACHUSETTS

Braintree 02185 (Boston)  
719 Granite Street  
Phone: (781) 848-9810  
Fax: (781) 848-6759

Franklin 02038 (Boston)  
Franklin Industrial Park  
101E Constitution Blvd.  
Phone: (508) 520-8802  
Fax: (508) 528-8089

### MICHIGAN

Madison Heights 48071 (Detroit)  
30475 Stephenson Highway  
Phone: (248) 597-5000  
Fax: (248) 597-5004

### MINNESOTA

Minneapolis 55429  
5522 Lakeland Avenue North  
Phone: (763) 561-9080  
Fax: (763) 561-0653

### MISSOURI

North Kansas City 64116  
1141 Swift Avenue  
Phone: (816) 221-2070  
Fax: (816) 221-2897

St. Louis 63119

7574 Watson Road  
Phone: (314) 968-8950  
Fax: (314) 968-2790

### NEW YORK

Flushing 11365-1595 (N.Y.C.)  
175-25 Horace Harding Expwy.  
Phone: (718) 225-2040  
Fax: (718) 423-9619

### NORTH CAROLINA

Charlotte 28270  
9129 Monroe Road, Suite 115  
Phone: (704) 841-1176  
Fax: (704) 708-4625

### OHIO

Columbus 43214  
4560 Indianola Avenue  
Phone: (614) 263-0929  
Fax: (614) 263-1238

Cleveland 44125  
8001 Sweet Valley Drive  
Unit #19  
Phone: (216) 447-9030  
Fax: (216) 447-3097

### OREGON

Portland 97230  
4916 NE 122 nd Ave.  
Phone: (503) 252-0107  
Fax: (503) 252-2123

### PENNSYLVANIA

Willow Grove 19090  
520 North York Road  
Phone: (215) 658-1430  
Fax: (215) 658-1433

### TEXAS

Carrlton 75006 (Dallas)  
1300 Interstate 35 N, Suite 112  
Phone: (972) 446-2996  
Fax: (972) 446-8157

Houston 77055

West 10 Business Center  
1008 Wirt Road, Suite 120  
Phone: (713) 682-0334  
Fax: (713) 682-4867

### WASHINGTON

Auburn 98001 (Seattle)  
3320 West Valley HWY, North  
Building D, Suite 111  
Phone: (253) 333-8353  
Fax: (253) 333-9613

Authorized Service Stations are located in many large cities. Telephone **800-438-2486** or **731-541-6042** for assistance locating one. Parts and accessories for Porter-Cable-Delta products should be obtained by contacting any Porter-Cable-Delta Distributor, Authorized Service Center, or Porter-Cable-Delta Factory Service Center. If you do not have access to any of these, call **800-223-7278** and you will be directed to the nearest Porter-Cable-Delta Factory Service Center. Las Estaciones de Servicio Autorizadas están ubicadas en muchas grandes ciudades. Llame al **800-438-2486** ó al **731-541-6042** para obtener asistencia a fin de localizar una. Las piezas y los accesorios para los productos Porter-Cable-Delta deben obtenerse poniéndose en contacto con cualquier distribuidor Porter-Cable-Delta, Centro de Servicio Autorizado o Centro de Servicio de Fábrica Porter-Cable-Delta. Si no tiene acceso a ninguna de estas opciones, llame al **800-223-7278** y le dirigirán al Centro de Servicio de Fábrica Porter-Cable-Delta más cercano.

## CANADIAN PORTER-CABLE • DELTA SERVICE CENTERS

### ALBERTA

Bay 6, 2520-23rd St. N.E.  
Calgary, Alberta  
T2E 8L2  
Phone: (403) 735-6166  
Fax: (403) 735-6144

### BRITISH COLUMBIA

8520 Baxter Place  
Burnaby, B.C.  
V5A 4T8  
Phone: (604) 420-0102  
Fax: (604) 420-3522

### MANITOBA

1699 Dublin Avenue  
Winnipeg, Manitoba  
R3H 0H2  
Phone: (204) 633-9259  
Fax: (204) 632-1976

### ONTARIO

505 Southgate Drive  
Guelph, Ontario  
N1H 6M7  
Phone: (519) 836-2840  
Fax: (519) 767-4131

### QUÉBEC

1515 ave.  
St-Jean Baptiste,  
Québec, Québec  
G2E 5E2  
Phone: (418) 877-7112  
Fax: (418) 877-7123

1447, Begin  
St-Laurent, (Montréal),  
Québec  
H4R 1V8  
Phone: (514) 336-8772  
Fax: (514) 336-3505

The following are trademarks of PORTER-CABLE-DELTA (Las siguientes son marcas registradas de PORTER-CABLE S.A.): Auto-Set®, BAMMER®, B.O.S.S.®, Builder's Saw®, Contractor's Saw®, Contractor's Saw II™, Delta®, DELTACRAFT®, DELTAGRAM™, Delta Series 2000™, DURATRONIC™, Emc<sup>2</sup>™, FLEX®, Flying Chips™, FRAME SAW®, Homecraft®, INNOVATION THAT WORKS®, Jet-Lock®, JETSTREAM®, 'kickstand'®, LASERLOC®, MICRO-SET®, Micro-Set®, MIDI LATHE®, MORTEN™, NETWORK™, OMNIJIG®, POCKET CUTTER®, PORTA-BAND®, PORTA-PLANE®, PORTER-CABLE®&(design), PORTER-CABLE®PROFESSIONAL POWER TOOLS, Posi-Matic®, Q-3®&(design), QUICKSAND®&(design), QUICKSET™, QUICKSET II®, QUICKSET PLUS™, RIPTIDE™&(design), SAFE GUARD II®, SAFE-LOC®, Sanding Center®, SANDTRAP®&(design), SAW BOSS®, Sawbuck™, Sidekick®, SPEED-BLOC®, SPEEDMATIC®, SPEEDTRONIC®, STAIR EASE®, The American Woodshop®&(design), The Lumber Company®&(design), THE PROFESSIONAL EDGE®, THE PROFESSIONAL SELECT®, THIN-LINE™, TIGER®, TIGER CUB®, TIGER SAW®, TORQBUSTER®, TORQ-BUSTER®, TRU-MATCH™, TWIN-LITE®, UNIGUARD®, Unifence®, UNIFEEDER™, Unihead®, Uniplane™, Unirip®, Unisaw®, Univise®, Versa-Feeder®, VERSA-PLANE®, WHISPER SERIES®, WOODWORKER'S CHOICE™.

Trademarks noted with ™ and ® are registered in the United States Patent and Trademark Office and may also be registered in other countries. Las Marcas Registradas con el signo de ™ y ® son registradas por la Oficina de Registros y Patentes de los Estados Unidos y también pueden estar registradas en otros países.

Printed in U.S.A.

## Free Manuals Download Website

<http://myh66.com>

<http://usermanuals.us>

<http://www.somanuals.com>

<http://www.4manuals.cc>

<http://www.manual-lib.com>

<http://www.404manual.com>

<http://www.luxmanual.com>

<http://aubethermostatmanual.com>

Golf course search by state

<http://golfingnear.com>

Email search by domain

<http://emailbydomain.com>

Auto manuals search

<http://auto.somanuals.com>

TV manuals search

<http://tv.somanuals.com>