

Dell™ PowerEdge™ R815

# Hardware Owner's Manual

Regulatory Model: E05S  
Regulatory Type: E05S001



Download from [Www.Somanuals.com](http://Www.Somanuals.com). All Manuals Search And Download.

# Notes, Cautions, and Warnings



**NOTE:** A NOTE indicates important information that helps you make better use of your computer.



**CAUTION:** A CAUTION indicates potential damage to hardware or loss of data if instructions are not followed.



**WARNING:** A WARNING indicates a potential for property damage, personal injury, or death.

---

**Information in this document is subject to change without notice.**

© 2010 Dell Inc. All rights reserved.

Reproduction of these materials in any manner whatsoever without the written permission of Dell Inc. is strictly forbidden.

Trademarks used in this text: *Dell*, the *DELL* logo, and *PowerEdge* are trademarks of Dell Inc. *Microsoft*, *Windows*, and *Windows Server* are either trademarks or registered trademarks of Microsoft Corporation in the United States and/or other countries;

Other trademarks and trade names may be used in this document to refer to either the entities claiming the marks and names or their products. Dell Inc. disclaims any proprietary interest in trademarks and trade names other than its own.

Regulatory Model: E05S  
Regulatory Type: E05S001

February 2010

Rev. A00

# Contents

1	About Your System . . . . .	11
	<b>Accessing System Features During Startup . . . . .</b>	<b>11</b>
	<b>Front-Panel Features and Indicators . . . . .</b>	<b>12</b>
	<b>LCD Panel Features . . . . .</b>	<b>14</b>
	Home Screen . . . . .	15
	Setup Menu . . . . .	16
	View Menu . . . . .	17
	<b>Hard-Drive Indicator Patterns . . . . .</b>	<b>17</b>
	<b>Back-Panel Features and Indicators . . . . .</b>	<b>18</b>
	<b>Guidelines for Connecting External Devices . . . . .</b>	<b>20</b>
	<b>NIC Indicator Codes . . . . .</b>	<b>20</b>
	<b>Power Indicator Codes . . . . .</b>	<b>21</b>
	<b>LCD Status Messages . . . . .</b>	<b>22</b>
	Viewing Status Messages . . . . .	22
	Removing LCD Status Messages . . . . .	23
	<b>System Messages . . . . .</b>	<b>38</b>
	<b>Warning Messages . . . . .</b>	<b>51</b>
	<b>Diagnostics Messages . . . . .</b>	<b>51</b>
	<b>Alert Messages . . . . .</b>	<b>51</b>

<b>Other Information You May Need</b> . . . . .	<b>51</b>
<b>2 Using the System Setup Program and UEFI Boot Manager</b> . . . . .	<b>53</b>
<b>Choosing the System Boot Mode</b> . . . . .	<b>53</b>
<b>Entering the System Setup Program</b> . . . . .	<b>54</b>
Responding to Error Messages . . . . .	54
Using the System Setup Program Navigation Keys . . . . .	54
<b>System Setup Options</b> . . . . .	<b>55</b>
Main Screen . . . . .	55
Memory Settings Screen . . . . .	57
Processor Settings Screen . . . . .	58
SATA Settings Screen . . . . .	59
Boot Settings Screen . . . . .	59
Integrated Devices Screen . . . . .	60
PCI IRQ Assignments Screen . . . . .	61
Serial Communication Screen . . . . .	61
Power Management Screen . . . . .	62
System Security Screen . . . . .	63
Exit Screen . . . . .	64
<b>Entering the UEFI Boot Manager</b> . . . . .	<b>64</b>
Using the UEFI Boot Manager Navigation Keys . . . . .	65
UEFI Boot Manager Screen . . . . .	65
UEFI Boot Settings Screen . . . . .	66
System Utilities Screen . . . . .	66
<b>System and Setup Password Features</b> . . . . .	<b>66</b>
Using the System Password . . . . .	67
Using the Setup Password . . . . .	69

<b>Embedded System Management</b> . . . . .	<b>70</b>
<b>iDRAC6 Configuration Utility</b> . . . . .	<b>71</b>
Entering the iDRAC6 Configuration Utility . . . . .	71
<b>3 Installing System Components</b> . . . . .	<b>73</b>
<b>Recommended Tools.</b> . . . . .	<b>73</b>
<b>Inside the System</b> . . . . .	<b>73</b>
<b>Front Bezel (Optional)</b> . . . . .	<b>75</b>
Removing the Front Bezel . . . . .	75
Installing the Front Bezel . . . . .	75
<b>Opening and Closing the System</b> . . . . .	<b>76</b>
Opening the System . . . . .	76
Closing the System . . . . .	77
<b>Hard Drives.</b> . . . . .	<b>78</b>
Removing a Hard-Drive Blank . . . . .	78
Installing a Hard-Drive Blank. . . . .	79
Removing a Hard-Drive Carrier. . . . .	80
Installing a Hard-Drive Carrier . . . . .	81
Removing a Hard Drive From a Hard-Drive Carrier. . . . .	82
Installing a Hard Drive Into a Hard-Drive Carrier. . . . .	82
<b>Optical Drive</b> . . . . .	<b>83</b>
Removing an Optical Drive . . . . .	83
Installing an Optical Drive . . . . .	84
<b>Power Supplies</b> . . . . .	<b>85</b>
Removing a Power Supply . . . . .	85
Installing a Power Supply . . . . .	87

Removing the Power Supply Blank . . . . .	87
Installing the Power Supply Blank . . . . .	87
<b>Cooling Shroud . . . . .</b>	<b>88</b>
Removing the Cooling Shroud . . . . .	88
Installing the Cooling Shroud . . . . .	89
<b>Front-Chassis Assembly . . . . .</b>	<b>90</b>
<b>System Memory . . . . .</b>	<b>92</b>
General Memory Module Installation Guidelines . . . . .	93
Memory Sparing Support . . . . .	93
Installing Memory Modules . . . . .	98
Removing Memory Modules . . . . .	100
<b>Cooling Fans . . . . .</b>	<b>101</b>
Removing a Cooling Fan . . . . .	101
Installing a Cooling Fan . . . . .	103
Removing the Cooling Fan Assembly . . . . .	103
Installing the Cooling Fan Assembly . . . . .	104
<b>Internal USB Memory Key . . . . .</b>	<b>105</b>
<b>Internal NIC Hardware Key . . . . .</b>	<b>106</b>
<b>Expansion Cards and Expansion-Card Risers . . . . .</b>	<b>107</b>
Expansion Card Installation Guidelines . . . . .	107
Installing an Expansion Card . . . . .	109
Removing an Expansion Card . . . . .	111
Removing Expansion-Card Riser 1 . . . . .	112
Installing Expansion-Card Riser 1 . . . . .	114
Removing Expansion-Card Riser 2 . . . . .	114
Installing Expansion-Card Riser 2 . . . . .	115
<b>Integrated Storage Controller Card . . . . .</b>	<b>116</b>

Removing the Integrated Storage Controller Card . . . . .	116
Installing the Integrated Storage Controller Card . . . . .	118
<b>RAID Battery (Optional) . . . . .</b>	<b>119</b>
Removing a RAID Battery. . . . .	119
Installing the RAID Battery . . . . .	120
<b>iDRAC6 Enterprise Card (Optional) . . . . .</b>	<b>121</b>
Removing an iDRAC6 Enterprise Card . . . . .	121
Installing an iDRAC6 Enterprise Card . . . . .	122
<b>VFlash Media (Optional) . . . . .</b>	<b>123</b>
Removing a VFlash Media Card . . . . .	123
Installing a VFlash Media Card . . . . .	123
<b>Internal Dual SD Module (Optional) . . . . .</b>	<b>124</b>
Removing the Internal Dual SD Module . . . . .	124
Installing the Internal Dual SD Module. . . . .	125
<b>Processors . . . . .</b>	<b>126</b>
Removing a Processor . . . . .	126
Installing a Processor . . . . .	130
<b>System Battery . . . . .</b>	<b>132</b>
Replacing the System Battery . . . . .	132
<b>SAS Backplane . . . . .</b>	<b>134</b>
Removing the SAS Backplane . . . . .	134
Installing the SAS Backplane . . . . .	136
<b>Power Distribution Board . . . . .</b>	<b>136</b>
Removing the Power Distribution Board . . . . .	136
Replacing the Power Distribution Board . . . . .	139
<b>Control Panel Assembly . . . . .</b>	<b>140</b>

Removing the Control Panel Display Module . . . . .	140
Installing the Control Panel Display Module . . . . .	141
Removing the Control Panel Board . . . . .	143
Installing the Control Panel Board . . . . .	144
<b>System Board Assembly . . . . .</b>	<b>144</b>
Removing the System Board Assembly. . . . .	145
Installing the System Board Assembly . . . . .	148
<b>4 Troubleshooting Your System . . . . .</b>	<b>151</b>
<b>Safety First—For You and Your System . . . . .</b>	<b>151</b>
<b>Troubleshooting System Startup Failure. . . . .</b>	<b>151</b>
<b>Troubleshooting External Connections . . . . .</b>	<b>151</b>
<b>Troubleshooting the Video Subsystem. . . . .</b>	<b>152</b>
<b>Troubleshooting a USB Device . . . . .</b>	<b>152</b>
<b>Troubleshooting a Serial I/O Device. . . . .</b>	<b>153</b>
<b>Troubleshooting a NIC . . . . .</b>	<b>153</b>
<b>Troubleshooting a Wet System. . . . .</b>	<b>154</b>
<b>Troubleshooting a Damaged System. . . . .</b>	<b>155</b>
<b>Troubleshooting the System Battery . . . . .</b>	<b>156</b>
<b>Troubleshooting Power Supplies . . . . .</b>	<b>157</b>
<b>Troubleshooting System Cooling Problems . . . . .</b>	<b>157</b>
Troubleshooting a Fan . . . . .	158
<b>Troubleshooting System Memory . . . . .</b>	<b>159</b>



	<b>Troubleshooting an Internal USB Key . . . . .</b>	<b>162</b>
	<b>Troubleshooting an SD Card . . . . .</b>	<b>163</b>
	<b>Troubleshooting an Optical Drive . . . . .</b>	<b>164</b>
	<b>Troubleshooting a Hard Drive . . . . .</b>	<b>165</b>
	<b>Troubleshooting a Storage Controller. . . . .</b>	<b>166</b>
	<b>Troubleshooting Expansion Cards. . . . .</b>	<b>167</b>
	<b>Troubleshooting the Processors. . . . .</b>	<b>168</b>
<b>5</b>	<b>Running the System Diagnostics. . . . .</b>	<b>171</b>
	<b>Using Online Diagnostics . . . . .</b>	<b>171</b>
	<b>Embedded System Diagnostics Features . . . . .</b>	<b>171</b>
	<b>When to Use the Embedded System Diagnostics . . . .</b>	<b>172</b>
	<b>Running the Embedded System Diagnostics . . . . .</b>	<b>172</b>
	<b>System Diagnostics Testing Options . . . . .</b>	<b>172</b>
	<b>Using the Custom Test Options . . . . .</b>	<b>173</b>
	Selecting Devices for Testing . . . . .	173
	Selecting Diagnostics Options . . . . .	173
	Viewing Information and Results. . . . .	173
<b>6</b>	<b>Jumpers and Connectors . . . . .</b>	<b>175</b>
	<b>System Board Jumper . . . . .</b>	<b>175</b>
	<b>System Board Connectors . . . . .</b>	<b>176</b>
	<b>SAS Backplane Board Connectors . . . . .</b>	<b>179</b>

<b>Power Distribution Board Connectors</b> . . . . .	<b>180</b>
<b>Expansion-Card Riser-Board Components and PCIe Buses</b> . . . . .	<b>181</b>
<b>Disabling a Forgotten Password</b> . . . . .	<b>183</b>
<b>7 Getting Help</b> . . . . .	<b>185</b>
<b>Contacting Dell</b> . . . . .	<b>185</b>
<b>Index</b> . . . . .	<b>187</b>

# About Your System

## Accessing System Features During Startup

The following keystrokes provide access to system features during startup.



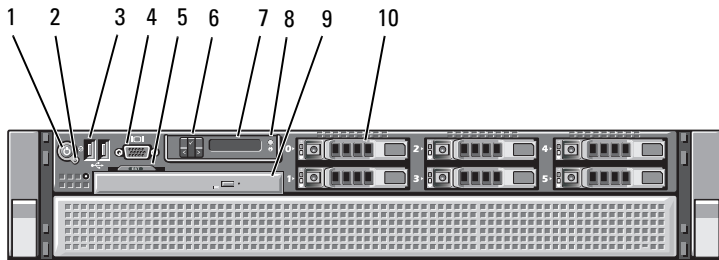

Keystroke	Description
<F2>	Enters the System Setup program. See "Using the System Setup Program and UEFI Boot Manager" on page 53.
<F10>	Enters System Services, which opens the Lifecycle Controller. The Lifecycle Controller allows you to access utilities such as embedded system diagnostics. For more information, see the Lifecycle Controller documentation at <a href="http://support.dell.com/manuals">support.dell.com/manuals</a> .
<F11>	Enters the BIOS Boot Manager or the UEFI Boot Manager, depending on the system's boot configuration. See "Using the System Setup Program and UEFI Boot Manager" on page 53.
<F12>	Starts PXE boot.
<Ctrl><E>	Enters the iDRAC Configuration Utility, which allows access to the System Event Log (SEL) and configuration of remote access to the system. For more information, see the iDRAC user documentation at <a href="http://support.dell.com/manuals">support.dell.com/manuals</a> .
<Ctrl><C>	Enters the SAS Configuration Utility. For more information, see the SAS adapter documentation at <a href="http://support.dell.com/manuals">support.dell.com/manuals</a> .
<Ctrl><R>	Enters the PERC configuration utility. For more information, see the PERC card documentation at <a href="http://support.dell.com/manuals">support.dell.com/manuals</a> .
<Ctrl><S>	Enters the utility to configure NIC settings for PXE boot. For more information, see the documentation for your integrated NIC at <a href="http://support.dell.com/manuals">support.dell.com/manuals</a> .

# Front-Panel Features and Indicators

Figure 1-1. Front-Panel Features and Indicators



Item	Indicator, Button, or Connector	Icon	Description
1	Power-on indicator, power button		<p>The power-on indicator lights when the system power is on.</p> <p>The power button controls the DC power supply output to the system. When the system bezel is installed, the power button is not accessible.</p> <p><b>NOTE:</b> When powering on the system, the video monitor can take from several seconds to over two minutes to display an image, depending on the amount of memory installed in the system.</p> <p><b>NOTE:</b> On ACPI-compliant operating systems, turning off the system using the power button causes the system to perform a graceful shutdown before power to the system is turned off.</p>

Item	Indicator, Button, or Connector	Icon	Description
2	NMI button		<p>Used to troubleshoot software and device driver errors when using certain operating systems. This button can be pressed using the end of a paper clip.</p> <p>Use this button only if directed to do so by qualified support personnel or by the operating system's documentation.</p>
3	USB connectors (2)		Connect USB devices to the system. The ports are USB 2.0-compliant.
4	Video connector		Connects a monitor to the system.
5	System identification panel		A slide-out panel for system information including the Express Service Tag, embedded NIC MAC address, and iDRAC6 Enterprise card MAC address. Space is provided for an additional label.
6	LCD menu buttons		Allows you to navigate the control panel LCD menu.
7	LCD panel		<p>Provides system ID, status information, and system error messages.</p> <p>The LCD lights blue during normal system operation. The LCD lights amber when the system needs attention, and the LCD panel displays an error code followed by descriptive text.</p> <p><b>NOTE:</b> If the system is connected to AC power and an error has been detected, the LCD lights amber regardless of whether the system has been powered on.</p>
8	System identification button		The identification buttons on the front and back panels can be used to locate a particular system within a rack. When one of these buttons is pushed, the LCD panel on the front and the system status indicator on the back blink until one of the buttons is pushed again.

Item	Indicator, Button, or Connector	Icon	Description
9	Optical drive (optional)		One optional slim-line SATA DVD-ROM drive or DVD-RW drive.  <b>NOTE:</b> DVD devices are data only.
10	Hard drives		Up to six 2.5 inch, external hot-swappable SAS, SATA, or SSD hard drives.

## LCD Panel Features

The system's LCD panel provides system information and status and error messages to signify when the system is operating correctly or when the system needs attention. See "LCD Status Messages" on page 22 for information about specific status codes.

The LCD backlight lights blue during normal operating conditions and lights amber to indicate an error condition. When the system is in standby mode, the LCD backlight is off and can be turned on by pressing the Left, Select, or Right button on the LCD panel. The LCD backlight remains off if LCD messaging is turned off through the iDRAC6 utility, the LCD panel, or other tools.

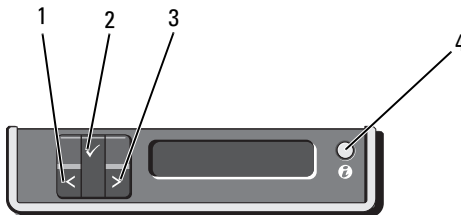

**Figure 1-2. LCD Panel Features**



Item	Buttons	Description
1	Left	Moves the cursor back in one-step increments.
2	Select	Selects the menu item highlighted by the cursor.
3	Right	Moves the cursor forward in one-step increments. During message scrolling: <ul style="list-style-type: none"> <li>• Press once to increase scrolling speed.</li> <li>• Press again to stop.</li> <li>• Press again to return to default scrolling speed.</li> <li>• Press again to repeat the cycle.</li> </ul>
4	System identification	Turns the system ID mode on (LCD panel flashes blue) and off. Press quickly to toggle the system ID on and off. If the system hangs during POST, press and hold the system ID button for more than 5 seconds to enter BIOS Progress mode.

## Home Screen

The Home screen displays user-configurable information about the system. This screen is displayed during normal system operation when there are no status messages or errors present. When the system is in standby mode, the LCD backlight turns off after 5 minutes of inactivity if there are no error messages. Press one of the three navigation buttons (Select, Left, or Right) to view the Home screen.

To navigate to the Home screen from another menu, continue to select the up arrow  until the Home icon  is displayed, and then select the Home icon.

From the Home screen, press the **Select** button to enter the main menu. See the following tables for information on the **Setup** and **View** submenus.

## Setup Menu



**NOTE:** When you select an option in the **Setup** menu, you must confirm the option before proceeding to the next action.

Option	Description
DRAC	Select <b>DHCP</b> or <b>Static IP</b> to configure the network mode. If <b>Static IP</b> is selected, the available fields are <b>IP</b> , <b>Subnet (Sub)</b> , and <b>Gateway (Gtw)</b> . Select <b>Setup DNS</b> to enable DNS and to view and set the IP addresses of DNS servers. Two separate DNS entries are available so that a primary and secondary DNS server may be configured.
Set error	Select <b>SEL</b> to display LCD error messages in a format that matches the IPMI description in the SEL. This can be useful when trying to match an LCD message with an SEL entry.  Select <b>Simple</b> to display LCD error messages in a simplified user-friendly format. See "LCD Status Messages" on page 22 for a list of messages in this format.
Set home	Select the default information to be displayed on the LCD Home screen. See "View Menu" on page 17 to see the options and option items that can be displayed by default on the Home screen.



## View Menu

Option	Description
DRAC IP	Displays the IPv4 or IPv6 addresses for the iDRAC6. Addresses include DNS (Primary and Secondary), Gateway, IP, and Subnet (IPv6 does not have Subnet).
MAC	Displays the MAC addresses for DRAC, iSCSI $n$ , or NET $n$ .
Name	Displays the name of the Host, Model, or User String for the system.
Number	Displays the Asset tag or the Service tag for the system.
Power	Displays the power output of the system in BTU/hr or Watts. The display format can be configured in the Set home submenu of the Setup menu. See "Setup Menu" on page 16.
Temperature	Displays the temperature of the system in Celsius or Fahrenheit. The display format can be configured in the Set home submenu of the Setup menu. See "Setup Menu" on page 16.

## Hard-Drive Indicator Patterns

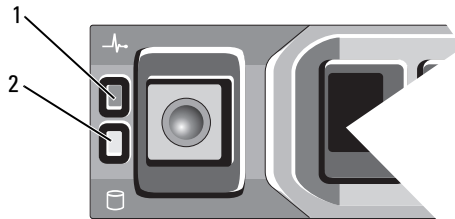



- 1 hard-drive status indicator (green and amber)
- 2 hard-drive activity indicator (green)



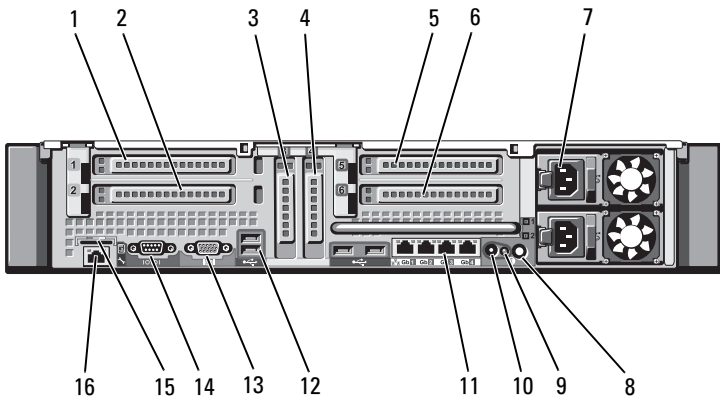

Drive-Status Indicator Pattern (RAID Only)	Condition
Blinks green two times per second	Identify drive/preparing for removal
Off	Drive ready for insertion or removal
	<b>NOTE:</b> The drive status indicator remains off until all hard drives are initialized after system power is applied. Drives are not ready for insertion or removal during this time.
Blinks green, amber, and off	Drive predicted failure
Blinks amber four times per second	Drive failed
Blinks green slowly	Drive rebuilding
Steady green	Drive online
Blinks green 3 seconds, amber 3 seconds, and off 6 seconds.	Rebuild aborted

## Back-Panel Features and Indicators

Figure 1-3. Back-Panel Features and Indicators



Item	Indicator, Button, or Connector	Icon	Description
1	PCIe slot 1		PCI Express (Generation 2) x8 link expansion slot (24.13 cm [9.5"] length).
2	PCIe slot 2		PCI Express (Generation 2) x4 link expansion slot (low-profile 24.13 cm [9.5"] maximum length, with a standard height bracket).
3	PCIe slot 3		PCI Express (Generation 2) x8 link expansion slot (low-profile 24.13 cm [9.5"] length).
4	PCIe slot 4		PCI Express (Generation 2) x8 link expansion slot (low-profile 24.13 cm [9.5"] length).
5	PCIe slot 5		PCI Express (Generation 2) x8 link expansion slot (24.13 cm [9.5"] length).
6	PCIe slot 6		PCI Express (Generation 2) x8 link expansion slot (24.13 cm [9.5"] length).
7	Power supplies (2)		1100 W power supplies.
8	System identification button		The identification buttons on the front and back panels can be used to locate a particular system within a rack. When one of these buttons is pushed, the LCD panel on the front and the system status indicator on the back blink until one of the buttons is pushed again.
9	System status indicator		Lights blue during normal system operation. Lights amber when the system needs attention due to a problem.
10	System identification connector		Connects the optional system status indicator assembly through the optional cable management arm.
11	Ethernet connectors (4)		Integrated 10/100/1000 NIC connectors.

Item	Indicator, Button, or Connector	Icon	Description
12	USB connectors (4)		Connect USB devices to the system. The ports are USB 2.0-compliant.
13	Video connector		Connects a monitor to the system.
14	Serial connector		Connects a serial device to the system.
15	VFlash media slot (optional)		Connects an external SD memory card for the optional iDRAC6 Enterprise card.
16	iDRAC6 Enterprise port (optional)		Dedicated management port for the optional iDRAC6 Enterprise card.

## Guidelines for Connecting External Devices

- Turn off power to the system and external devices before attaching a new external device. Turn on any external devices before turning on the system (unless the documentation for the device specifies otherwise).
- Ensure that the appropriate driver for the attached device has been installed on the system.
- If it is necessary to enable ports on your system, see "Using the System Setup Program and UEFI Boot Manager" on page 53.

## NIC Indicator Codes

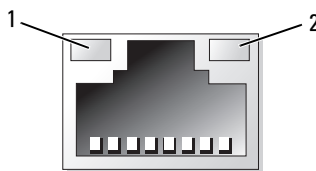

1 link indicator

2 activity indicator

<b>Indicator</b>	<b>Indicator Code</b>
Link and activity indicators are off	The NIC is not connected to the network.
Link indicator is green	The NIC is connected to a valid network link at 1000 Mbps.
Link indicator is amber	The NIC is connected to a valid network link at 10 or 100 Mbps.
Activity indicator is green blinking	Network data is being sent or received.

## Power Indicator Codes

The power supplies have indicators that show whether power is present or whether a power fault has occurred.

- Not lit—AC power is not connected.
- Green—In standby mode, a green light indicates that a valid AC source is connected to the power supply and that the power supply is operational. When the system is on, a green light also indicates that the power supply is providing DC power to the system.
- Amber—Indicates a problem with the power supply.

**Figure 1-4. Power Supply Status Indicator**

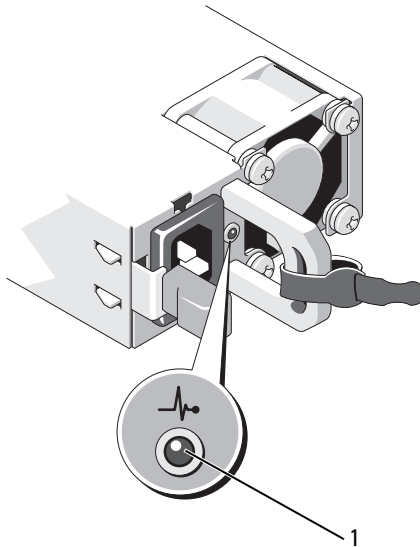

1 power supply status indicator

## LCD Status Messages

The LCD messages consist of brief text messages that refer to events recorded in the System Event Log (SEL). For information on the SEL and configuring system management settings, see the systems management software documentation.

 **NOTE:** If your system fails to boot, press the System ID button for at least 5 seconds until an error code appears on the LCD. Record the code, then see "Getting Help" on page 185.

### Viewing Status Messages

If a system error occurs, the LCD screen turns amber. Press the **Select** button to view the list of errors or status messages. Press the left and right buttons to highlight an error number, and press **Select** to view the error.

## Removing LCD Status Messages

For faults associated with sensors, such as temperature, voltage, fans, and so on, the LCD message is automatically removed when that sensor returns to a normal state. For other faults, you must take action to remove the message from the display:

- Clear the SEL—You can perform this task remotely, but you will lose the event history for the system.
- Power cycle—Turn off the system and disconnect it from the electrical outlet; wait approximately 10 seconds, reconnect the power cable, and restart the system.



**NOTE:** The following LCD status messages are displayed in the Simple format. See "Setup Menu" on page 16 to select the format in which the messages are displayed.

**Table 1-1. LCD Status Messages**

Code	Text	Causes	Corrective Actions
E1000	Failsafe voltage error. Contact support.	Check the system event log for critical failure events.	Remove AC power to the system for 10 seconds and restart the system.  If the problem persists, see "Getting Help" on page 185.
E1114	Ambient Temp exceeds allowed range.	Ambient temperature reached a point outside the allowed range.	See "Troubleshooting System Cooling Problems" on page 157.
E1116	Memory disabled, temp above range. Power cycle AC.	Memory exceeded allowable temperature and has been disabled to prevent damage to the components.	Remove AC power to the system for 10 seconds and restart the system.  See "Troubleshooting System Cooling Problems" on page 157. If the problem persists, see "Getting Help" on page 185.

<b>Code</b>	<b>Text</b>	<b>Causes</b>	<b>Corrective Actions</b>
E1119	Chipset # temp out of range. Check motherboard heatsinks.	Chipset temperature reached a point outside the allowed range.	See "Troubleshooting System Cooling Problems" on page 157.
E1210	Motherboard battery failure. Check battery.	CMOS battery is missing or the voltage is outside the allowable range.	See "Troubleshooting the System Battery" on page 156.
E1211	RAID Controller battery failure. Check battery.	RAID battery is either missing, bad, or unable to recharge due to thermal issues.	Reseat the RAID battery connector. See "Internal Dual SD Module (Optional)" on page 123 and "Troubleshooting System Cooling Problems" on page 157.
E1216	3.3V Regulator failure. Reseat PCIe cards.	3.3 V voltage regulator failed.	Remove and reseat the PCIe expansion cards. If the problem persists, see "Troubleshooting Expansion Cards" on page 166.
E1219	Disk Backplane power failure. Check BP power cable.	Storage backplane voltage regulator failed.	Remove and reconnect the backplane power cable. If the problem persists, see "Getting Help" on page 185.
E122C	CPU Power Fault. Power cycle AC.	A power fault was detected when powering up the processor(s).	Remove AC power to the system for 10 seconds and restart the system. If the problem persists, see "Getting Help" on page 185.



<b>Code</b>	<b>Text</b>	<b>Causes</b>	<b>Corrective Actions</b>
E122D	Memory Regulator # Failed. Reseat DIMMs.	One of the memory voltage regulators failed.	Reseat the memory modules. See "Troubleshooting System Memory" on page 159.
E122E	On-board regulator failed. Call support.	One of the on-board voltage regulators failed.	Remove AC power to the system for 10 seconds and restart the system.  If the problem persists, see "Getting Help" on page 185.
E1243	CPU # VCORE Regulator failure. Contact Support.	Processor voltage regulator failed.	Reseat the processor. See "Troubleshooting the Processors" on page 168.  If the problem persists, see "Getting Help" on page 185.
E1310	Fan ## RPM exceeding range. Check fan.	RPM of specified fan is outside the intended operating range.	See "Troubleshooting System Cooling Problems" on page 157.
E1313	Fan redundancy lost. Check fans.	The system is no longer fan redundant. Another fan failure would put the system at risk of over-heating.	Check LCD for additional scrolling messages. See "Troubleshooting a Fan" on page 158.
E1314	Critical system cooling loss. Check fans.	All fans have been removed from the system.	Ensure that the fans are properly installed. See "Troubleshooting a Fan" on page 158.
E1410	System Fatal Error detected.	A fatal system error detected.	Check LCD for additional scrolling messages. Remove AC power to the system for 10 seconds and restart the system.  If the problem persists, see "Getting Help" on page 185.

<b>Code</b>	<b>Text</b>	<b>Causes</b>	<b>Corrective Actions</b>
E1414	CPU # temp exceeding range. Check CPU heatsink.	Specified processor is out of acceptable temperature range.	Ensure that the processor heat sinks are properly installed. See "Troubleshooting the Processors" on page 168 and "Troubleshooting System Cooling Problems" on page 157.
E1418	CPU # not detected. Check CPU is seated properly.	Specified processor is missing or bad and the system is in an unsupported configuration.	Ensure that the specified processor is properly installed. See "Troubleshooting the Processors" on page 168.
E141C	Unsupported CPU configuration . Check CPU or BIOS revision.	Processors are in an unsupported configuration.	Ensure that your processors match and conform to the type described in the processor technical specifications outlined in your system's <i>Getting Started Guide</i> .
E141F	CPU # protocol error. Power cycle AC.	The system BIOS reported a processor protocol error.	Remove AC power to the system for 10 seconds and restart the system.  If the problem persists, see "Getting Help" on page 185.
E1420	CPU Bus parity error. Power cycle AC.	The system BIOS reported a processor bus parity error.	Remove AC power to the system for 10 seconds and restart the system.  If the problem persists, see "Getting Help" on page 185.

<b>Code</b>	<b>Text</b>	<b>Causes</b>	<b>Corrective Actions</b>
E1421	CPU # initialization error. Power cycle AC.	The system BIOS reported a processor initialization error.	Remove AC power to the system for 10 seconds and restart the system.  If the problem persists, see "Getting Help" on page 185.
E1422	CPU # machine check error. Power cycle AC.	The system BIOS reported a machine check error.	Remove AC power to the system for 10 seconds and restart the system.  If the problem persists, see "Getting Help" on page 185.
E1610	Power Supply # (#### W) missing. Check power supply.	Specified power supply removed or is missing from the system.	See "Troubleshooting Power Supplies" on page 157.
E1614	Power Supply # (#### W) error. Check power supply.	Specified power supply failed.	See "Troubleshooting Power Supplies" on page 157.
E1618	Predictive failure on Power Supply # (#### W). Check PSU.	A power supply fan failure, an over-temperature condition, or power supply communication error caused the predictive warning of an impending power supply failure.	See "Troubleshooting Power Supplies" on page 157.
E161C	Power Supply # (#### W) lost AC power. Check PSU cables.	Specified power supply is installed but lost its AC input.	Check the AC power source for the specified power supply. If the problem persists, see "Troubleshooting Power Supplies" on page 157.

<b>Code</b>	<b>Text</b>	<b>Causes</b>	<b>Corrective Actions</b>
E1620	Power Supply # (#### W) AC power error. Check PSU cables.	Specified power supply's AC input is outside the allowable range.	Check the AC power source for the specified power supply. If the problem persists, see "Troubleshooting Power Supplies" on page 157.
E1624	Lost power supply redundancy. Check PSU cables.	The power supply subsystem is no longer redundant. If the remaining power supply fails, the system will shut down.	See "Troubleshooting Power Supplies" on page 157.
E1629	Power required > PSU wattage. Check PSU and config.	The system configuration requires more power than the power supplies can provide, even with throttling.	Turn off power to the system, check if adequate power is supplied to the system. See the <i>Getting Started Guide</i> for information on the System power requirements.
E1631	System power draw exceeded threshold. Contact support.	Processor and memory throttling is not sufficient to keep system power consumption below the maximum safe level with the current power supply configuration.	Remove AC power to the system for 10 seconds and restart the system.  If the problem persists, see "Getting Help" on page 185.
E1632	FailSafe event. Contact support.	The processors and memory have been throttled to keep system power consumption below the maximum safe level with current power supply configuration.	Remove AC power to the system for 10 seconds and restart the system.  If the problem persists, see "Getting Help" on page 185.

<b>Code</b>	<b>Text</b>	<b>Causes</b>	<b>Corrective Actions</b>
E1710	I/O channel check error. Review & clear SEL.	The system BIOS reported an I/O channel check.	Check the SEL for more information and then clear the SEL. Remove AC power to the system for 10 seconds and restart the system.  If the problem persists, see "Getting Help" on page 185.
E1711	PCI parity error on Bus ## Device ## Function ##.	The system BIOS reported a PCI parity error on a component that resides in PCI configuration space at bus ##, device ##, function ##.	Remove and reseat the PCIe expansion cards. If the problem persists, see "Troubleshooting Expansion Cards" on page 166.
	PCI parity error on Slot #. Review & clear SEL.	The system BIOS reported a PCI parity error on a component that resides in the specified slot.	Remove and reseat the PCIe expansion cards. If the problem persists, see "Troubleshooting Expansion Cards" on page 166.
E1712	PCI system error on Bus ## Device ## Function ##.	The system BIOS reported a PCI system error on a component that resides in PCI configuration space at bus ##, device ##, function ##.	Remove and reseat the PCIe expansion cards. If the problem persists, see "Troubleshooting Expansion Cards" on page 166.
	PCI system error on Slot #. Review & clear SEL.	The system BIOS reported a PCI system error on a component that resides in the specified slot.	Remove and reseat the expansion-card riser that provides the specified slot. See "Expansion Cards and Expansion-Card Risers" on page 107. If the problem persists, the riser card or system board is faulty. See "Getting Help" on page 185.

<b>Code</b>	<b>Text</b>	<b>Causes</b>	<b>Corrective Actions</b>
E1714	Unknown error. Review & clear SEL.	The system BIOS determined there has been an error in the system, but is unable to determine its origin.	Check the SEL for more information and then clear the SEL. Remove AC power to the system for 10 seconds and restart the system.  If the problem persists, see "Getting Help" on page 185.
E1715	Fatal I/O Error. Review & clear SEL.	The system BIOS determined there has been a fatal error in the system.	Check the SEL for more information, and then clear the SEL. Remove AC power to the system for 10 seconds, and restart the system.  If the problem persists, see "Getting Help" on page 185.
E1716	Chipset IERR Bus ## Dev ## Function ##. Review & clear SEL.	The system BIOS reported a chipset internal error that resides in bus ##, device ##, function ##.	Check the SEL for more information, and then clear the SEL. Remove AC power to the system for 10 seconds, and restart the system.  If the problem persists, see "Getting Help" on page 185.
E1717	CPU # internal error. Review & clear SEL.	The system BIOS determined that the specified processor has had an internal error.	Check the SEL for more information, and then clear the SEL. Remove AC power to the system for 10 seconds, and restart the system.  If the problem persists, see "Getting Help" on page 185.

<b>Code</b>	<b>Text</b>	<b>Causes</b>	<b>Corrective Actions</b>
E171F	PCIe fatal error on Bus ## Device ## Function ##.	The system BIOS reported a PCIe fatal error on a component that resides in PCI configuration space at bus ##, device ##, function ##.	Remove and reseat the PCIe expansion cards. If the problem persists, see "Troubleshooting Expansion Cards" on page 166.
	PCIe fatal error on Slot #. Review & clear SEL.	The system BIOS reported a PCIe fatal error on a component that resides in the specified slot.	Remove and reseat the expansion-card riser. See "Expansion Cards and Expansion-Card Risers" on page 107. If the problem persists, the riser card or system board is faulty. See "Getting Help" on page 185.
E1810	Hard drive ## fault. Review & clear SEL.	The specified hard drive experienced a fault.	See "Troubleshooting a Hard Drive" on page 164.
E1812	Hard drive ## removed. Check drive.	The specified hard drive is removed from the system.	Information only.
E1A11	PCI Riser hardware & configuration mismatch. Reconfigure.	PCIe risers are not configured correctly. Some invalid configurations prevent the system from powering on.	Reinstall the expansion-card riser. See "Expansion Cards and Expansion-Card Risers" on page 107. If the problem persists, the riser card or system board is faulty. See "Getting Help" on page 185.
E1A12	PCI Riser not detected. Check Riser.	One or both of the PCIe risers are missing. This prevents the system from powering on.	Reinstall the missing riser card(s). See "Installing Expansion-Card Riser 1" on page 113 and "Installing Expansion-Card Riser 2" on page 114.

<b>Code</b>	<b>Text</b>	<b>Causes</b>	<b>Corrective Actions</b>
E1813	Internal Dual SD Module Card # failed. Check SD card.	The internal dual SD module card failed.	Reseat the internal dual SD module card.  If the problem persists, see "Getting Help" on page 185.
E1814	Internal SD Module Card # write-protected. Check SD card.	The internal dual SD module card is write-protected and cannot be used.	Change the write-protect switch setting on SD card.
E1815	Internal Dual SD Module redundancy lost. Check SD cards.	The internal dual SD module bootable media is no longer redundant.	Reseat the internal dual SD module card.  If the problem persists, see "Getting Help" on page 185.
E1A14	SAS cable A failure. Check connection.	SAS cable A is missing or bad.	Reseat the cable. If the problem persists, replace the cable.  If the problem persists, see "Getting Help" on page 185.
E1A15	SAS cable B failure. Check connection.	SAS cable B is missing or bad.	Reseat the cable. If the problem persists, replace the cable.  If the problem persists, see "Getting Help" on page 185.
E1A1D	Control panel USB cable not detected. Check cable.	USB cable to the control panel is missing or bad.	Reseat the cable. If the problem persists, replace the cable.  If the problem persists, see "Getting Help" on page 185.



<b>Code</b>	<b>Text</b>	<b>Causes</b>	<b>Corrective Actions</b>
E2010	Memory not detected. Inspect DIMMs.	No memory detected in the system.	Install memory or reset the memory modules. See "Installing Memory Modules" on page 97 or "Troubleshooting System Memory" on page 159.
E2011	Memory configuration failure. Check DIMMs.	Memory detected, but is not configurable. Error detected during memory configuration.	See "Troubleshooting System Memory" on page 159.
E2012	Memory configured but unusable. Check DIMMs.	Memory configured, but is unusable.	See "Troubleshooting System Memory" on page 159.
E2013	BIOS unable to shadow memory. Check DIMMs.	The system BIOS failed to copy its flash image into memory.	See "Troubleshooting System Memory" on page 159.
E2014	CMOS RAM failure. Power cycle AC.	CMOS failure. CMOS RAM not functioning properly.	Remove AC power to the system for 10 seconds and restart the system.  If the problem persists, see "Getting Help" on page 185.
E2015	DMA Controller failure. Power cycle AC.	DMA controller failure.	Remove AC power to the system for 10 seconds and restart the system.  If the problem persists, see "Getting Help" on page 185.
E2016	Interrupt Controller failure. Power cycle AC.	Interrupt controller failure.	Remove AC power to the system for 10 seconds and restart the system.  If the problem persists, see "Getting Help" on page 185.

<b>Code</b>	<b>Text</b>	<b>Causes</b>	<b>Corrective Actions</b>
E2017	Timer refresh failure. Power cycle AC.	Timer refresh failure.	Remove AC power to the system for 10 seconds and restart the system.  If the problem persists, see "Getting Help" on page 185.
E2018	Programmable Timer error. Power cycle AC.	Programmable interval timer error.	Remove AC power to the system for 10 seconds and restart the system.  If the problem persists, see "Getting Help" on page 185.
E2019	Parity error. Power cycle AC.	Parity error.	Remove AC power to the system for 10 seconds and restart the system.  If the problem persists, see "Getting Help" on page 185.
E201A	SuperIO failure. Power cycle AC.	SIO failure.	Remove AC power to the system for 10 seconds and restart the system.  If the problem persists, see "Getting Help" on page 185.
E201B	Keyboard controller error. Power cycle AC.	Keyboard controller failure.	Remove AC power to the system for 10 seconds and restart the system.  If the problem persists, see "Getting Help" on page 185.
E201C	SMI initialization failure. Power cycle AC.	System management interrupt (SMI) initialization failure.	Remove AC power to the system for 10 seconds and restart the system.  If the problem persists, see "Getting Help" on page 185.

<b>Code</b>	<b>Text</b>	<b>Causes</b>	<b>Corrective Actions</b>
E201D	Shutdown test failure. Power cycle AC.	BIOS shutdown test failure.	Remove AC power to the system for 10 seconds and restart the system.  If the problem persists, see "Getting Help" on page 185.
E201E	POST memory test failure. Check DIMMs.	BIOS POST memory test failure.	See "Troubleshooting System Memory" on page 159.  If the problem persists, see "Getting Help" on page 185.
E2020	CPU configuration failure. Check screen message.	Processor configuration failure.	Check screen for specific error messages. See "Troubleshooting the Processors" on page 168.
E2021	Incorrect memory configuration. Review User Guide.	Incorrect memory configuration.	Check screen for specific error messages. See "Troubleshooting System Memory" on page 159.
E2022	General failure during POST. Check screen message.	General failure after video.	Check screen for specific error messages.
E2026	Memory initialization error. Contact support.	Invalid memory configuration.	Ensure that the memory modules are installed in a valid configuration. See "General Memory Module Installation Guidelines" on page 93. See "Getting Help" on page 185.

<b>Code</b>	<b>Text</b>	<b>Causes</b>	<b>Corrective Actions</b>
E2110	Multibit Error on DIMM ##. Reseat DIMM.	The memory module in slot "##" has had a multi-bit error (MBE).	Reseat the memory module in its socket.  If the problem persists, see "Troubleshooting System Memory" on page 159.
E2111	SBE log disabled on DIMM ##. Reseat DIMM.	The system BIOS disabled memory single-bit error (SBE) logging and will not log any more SBEs until the system is rebooted. "##" represents the memory module implicated by the BIOS.	Reseat the memory module in its socket.  If the problem persists, see "Troubleshooting System Memory" on page 159.
E2112	Memory spared on Card x DIMM ##. Power cycle AC.	The system BIOS spared the memory because it determined that the memory has too many errors.	Remove AC power to the system for 10 seconds and restart the system.  If the problem persists, see "Troubleshooting System Memory" on page 159.
I1910	Intrusion detected. Check chassis cover.	System cover removed.	Replace the chassis cover or ensure the chassis cover is properly installed. See "Closing the System" on page 77.
I1911	LCD Log Full. Check SEL to review all Errors.	LCD overflow message. A maximum of ten error messages can display sequentially on the LCD. The eleventh message instructs the user to check the SEL for details on the events.	Check the SEL for details on the events.  Remove AC power to the system for 10 seconds or clear the SEL.
I1912	SEL full. Review & clear log.	The SEL is full of events and is unable to log any more.	Check the SEL for more information and then clear the SEL.

<b>Code</b>	<b>Text</b>	<b>Causes</b>	<b>Corrective Actions</b>
W1100	CPU VCORE Regulator temp exceeding range. Check fans.	The regulator temperature reached a point outside the allowed range.	See "Troubleshooting System Cooling Problems" on page 157. If the problem persists, see "Getting Help" on page 185.
W1102	Mem Voltage Regulator temp exceeding range. Check fans	The regulator temperature reached a point outside the allowed range.	See "Troubleshooting System Cooling Problems" on page 157. If the problem persists, see "Getting Help" on page 185.
W1228	RAID Controller battery capacity < 24hr.	Warns predictively that the RAID battery has less than 24 hours of charge left.	Allow RAID battery to charge to greater than 24 hours of sustained charge.  If problem persists, replace the RAID battery. See "Internal Dual SD Module (Optional)" on page 123.
W1630	Power supply redundancy degraded. Check PSU cables.	The power supply subsystem is no longer fully redundant.	Reseat the power supplies. See "Troubleshooting Power Supplies" on page 157.  If the problem persists, see "Getting Help" on page 185.

**NOTE:** For the full name of an abbreviation or acronym used in this table, see the *Glossary* at [support.dell.com/manuals](http://support.dell.com/manuals).

# System Messages

System messages appear on the screen to notify you of a possible problem with the system.



**NOTE:** If you receive a system message not listed in the table, check the documentation for the application that is running when the message appears or the operating system's documentation for an explanation of the message and recommended action.

**Table 1-2. System Messages**

Message	Causes	Corrective Actions
Alert! iDRAC6 not responding. Rebooting.	The iDRAC6 is not responding to BIOS communication either because it is not functioning properly or has not completed initialization. The system will reboot.	Wait for the system to reboot.
Alert! iDRAC6 not responding. Power required may exceed PSU wattage. Alert! Continuing system boot accepts the risk that system may power down without warning.	The iDRAC6 has stopped responding. The iDRAC6 was remotely reset while the system was booting. After AC recovery, the iDRAC6 takes longer than normal to boot.	Remove AC power to the system for 10 seconds and restart the system.

<b>Message</b>	<b>Causes</b>	<b>Corrective Actions</b>
Alert! Node Interleaving disabled! Memory configuration does not support Node Interleaving.	The memory configuration has changed (for example, a memory module has failed) so that node interleaving cannot be supported. The system will run but without node interleaving.	Ensure that the memory modules are installed in a configuration that supports node interleaving. Check other system messages for additional information for possible causes. For memory configuration information, see "General Memory Module Installation Guidelines" on page 93. If the problem persists, see "Troubleshooting System Memory" on page 159.
Alert! Power required exceeds PSU wattage. Check PSU and system configuration. Alert! Continuing system boot accepts the risk that system may power down without warning.	The system configuration of processor(s), memory modules, and expansion cards may not be supported by the power supplies.	If any system components were just upgraded, return the system to the previous configuration. If the system boots without this warning, then the replaced component(s) are not supported with this power supply. If Energy Smart power supplies are installed, replace them with the High Output power supplies to use the components. See "Power Supplies" on page 85.
Alert! Redundant memory disabled! Memory configuration does not support redundant memory.	Redundant memory was enabled in the system setup program, but the current configuration does not support redundant memory. A memory module may be faulty.	Check the memory modules for failure. See "Troubleshooting System Memory" on page 159. Reset the memory setting, if appropriate. See "Using the System Setup Program and UEFI Boot Manager" on page 53.

<b>Message</b>	<b>Causes</b>	<b>Corrective Actions</b>
Alert! System fatal error during previous boot.	An error caused the system to reboot.	Check other system messages for additional information for possible causes.
BIOS MANUFACTURING MODE detected. MANUFACTURING MODE will be cleared before the next boot. System reboot required for normal operation.	System is in manufacturing mode.	Reboot to take the system out of manufacturing mode.
BIOS Update Attempt Failed!	Remote BIOS update attempt failed.	Retry the BIOS update. If the problem persists, see "Getting Help" on page 185.
Caution! NVRAM_CLR jumper is installed on system board.	NVRAM_CLR jumper is installed in the clear setting. CMOS has been cleared.	Move the NVRAM_CLR jumper to the default position (pins 3 and 5). See Figure 6-1 for jumper location. Restart the system and re-enter the BIOS settings. See "Using the System Setup Program and UEFI Boot Manager" on page 53.
CPU set to minimum frequency.	The processor speed may be intentionally set lower for power conservation.	If not an intentional setting, check any other system messages for possible causes.



<b>Message</b>	<b>Causes</b>	<b>Corrective Actions</b>
CPUs with different cache sizes detected.  CPUs with different core sizes detected! System halted.  CPUs with different power rating detected! System halted.	Mismatched processors have been installed in the system.	Ensure that all processors have the same cache size, number of cores, and power rating. Ensure that the processors are properly installed. See "Processors" on page 125.
Current boot mode is set to UEFI. Please ensure compatible bootable media is available. Use the system setup program to change the boot mode as needed.	The system failed to boot because UEFI boot mode is enabled in BIOS and the boot operating system is non-UEFI.	Ensure that the boot mode is set correctly and that the proper bootable media is available. See "Using the System Setup Program and UEFI Boot Manager" on page 53.
Decreasing available memory.	Faulty or improperly installed memory modules.	Reseat the memory modules. See "Troubleshooting System Memory" on page 159.
Embedded NICx and NICy: OS NIC=<ENABLED /DISABLED>, Management Shared NIC= <ENABLED /DISABLED>	The operating system NIC interface is set in BIOS. The Management Shared NIC interface is set in management tools.	Check the system management software or the System Setup program for NIC settings. If a problem is indicated, see "Troubleshooting a NIC" on page 153.

<b>Message</b>	<b>Causes</b>	<b>Corrective Actions</b>
Error 8602 - Auxiliary Device Failure. Verify that mouse and keyboard are securely attached to correct connectors.	Mouse or keyboard cable is loose or improperly connected.  Defective mouse or keyboard.	Reseat the mouse or keyboard cable.  Ensure that the mouse or keyboard is operational. See "Troubleshooting a USB Device" on page 152.
Gate A20 failure.	Faulty keyboard controller; faulty system board.	See "Getting Help" on page 185.
General failure.	The operating system is unable to carry out the command.	This message is usually followed by specific information. Note the information, and take the appropriate action to resolve the problem.
Invalid configuration information - please run SETUP program.	An invalid system configuration caused a system halt.	Run the System Setup program and review the current settings. See "Using the System Setup Program and UEFI Boot Manager" on page 53.
Invalid PCIe card found in the Internal_Storage slot!	The system halted because an invalid PCIe expansion card is installed in the dedicated storage controller slot.	Remove the PCIe expansion card and install the integrated storage controller in the dedicated slot. See "VFlash Media (Optional)" on page 122.
Keyboard controller failure.	Faulty keyboard controller; faulty system board.	See "Getting Help" on page 185.
Keyboard data line failure.  Keyboard stuck key failure.	Keyboard cable connector is improperly connected or the keyboard is defective.	Reseat the keyboard cable. If the problem persists, see "Troubleshooting a USB Device" on page 152.

<b>Message</b>	<b>Causes</b>	<b>Corrective Actions</b>
Keyboard fuse has failed.	Overcurrent detected at the keyboard connector.	See "Getting Help" on page 185.
Local keyboard may not work because all user accessible USB ports are disabled. If operating locally, power cycle the system and enter system setup program to change settings.	The USB ports are disabled in the system BIOS.	Power down and restart the system using the power button, and then enter the System Setup program to enable the USB port(s). See "Entering the System Setup Program" on page 54.
Manufacturing mode detected.	System is in manufacturing mode.	Reboot to take the system out of manufacturing mode.
Memory tests terminated by keystroke.	POST memory test was terminated by pressing the spacebar.	Information only.
No boot device available.	Faulty or missing optical drive subsystem, hard drive, or hard-drive subsystem, or non-bootable USB key installed.	Use a bootable USB key, CD, or hard drive. If the problem persists, see "Troubleshooting an Internal USB Key" on page 161, "Troubleshooting a USB Device" on page 152, "Troubleshooting an Optical Drive" on page 163, and "Troubleshooting a Hard Drive" on page 164. See "Using the System Setup Program and UEFI Boot Manager" on page 53 for information on setting the order of boot devices.

<b>Message</b>	<b>Causes</b>	<b>Corrective Actions</b>
No boot sector on hard drive.	Incorrect configuration settings in System Setup program, or no operating system on hard drive.	Check the hard-drive configuration settings in the System Setup program. See "Using the System Setup Program and UEFI Boot Manager" on page 53. If necessary, install the operating system on your hard drive. See your operating system documentation.
No timer tick interrupt.	Faulty system board.	See "Getting Help" on page 185.
PCI BIOS failed to install.	PCIe device BIOS (Option ROM) checksum failure detected during shadowing. Cables to expansion card(s) loose; faulty or improperly installed expansion card(s).	Reseat the expansion card(s). Ensure that all appropriate cables are securely connected to the expansion card(s). If the problem persists, see "Troubleshooting Expansion Cards" on page 166.
PCIe Training Error: Expected Link Width is x, Actual Link Width is y.	Faulty or improperly installed PCIe card in the specified slot.	Reseat the PCIe card in the specified slot number. See "Troubleshooting Expansion Cards" on page 166. If the problem persists, see "Getting Help" on page 185.
Plug & Play Configuration Error.	Error encountered in initializing PCIe device; faulty system board.	Install the NVRAM_CLR jumper in the clear position (pins 1 and 3) and reboot the system. See Figure 6-1 for jumper location. If the problem persists, see "Troubleshooting Expansion Cards" on page 166.

<b>Message</b>	<b>Causes</b>	<b>Corrective Actions</b>
Read fault. Requested sector not found.	The operating system cannot read from the hard drive, optical drive, or USB device, the system could not find a particular sector on the disk, or the requested sector is defective.	Replace the optical medium, USB medium or device. Ensure that the SAS backplane, USB, or SATA cables are properly connected. See "Troubleshooting a USB Device" on page 152, "Troubleshooting an Optical Drive" on page 163, or "Troubleshooting a Hard Drive" on page 164 for the appropriate drive(s) installed in your system.
SATA Port x device not found.	There is no device connected to the specified SATA port.	Information only.
SATA port x device auto-sensing error.	The drive connected to the specified SATA port is faulty.	Replace the faulty drive.
SATA port x device configuration error.		
SATA port 0 device failure.		
Requested sector not found. Seek error. Seek operation failed.	Faulty hard drive, USB device, or USB medium.	Replace the USB medium or device. Ensure that the USB or SAS backplane cables are properly connected. See "Troubleshooting a USB Device" on page 152 or "Troubleshooting a Hard Drive" on page 164 for the appropriate drive(s) installed in your system.
Shutdown failure.	General system error.	See "Getting Help" on page 185.

<b>Message</b>	<b>Causes</b>	<b>Corrective Actions</b>
The amount of system memory has changed.	Memory has been added or removed or a memory module may be faulty.	If memory has been added or removed, this message is informative and can be ignored. If memory has not been added or removed, check the SEL to determine if single-bit or multi-bit errors were detected and replace the faulty memory module. See "Troubleshooting System Memory" on page 159.
Time-of-day clock stopped.	Faulty battery or faulty chip.	See "Troubleshooting the System Battery" on page 156.
Time-of-day not set - please run SETUP program.	Incorrect Time or Date settings; faulty system battery.	Check the Time and Date settings. See "Using the System Setup Program and UEFI Boot Manager" on page 53. If the problem persists, replace the system battery. See "System Battery" on page 131.
Timer chip counter 2 failed.	Faulty system board.	See "Getting Help" on page 185.
TPM or TCM configuration operation honored. System will now reset.	A Trusted Platform Module (TPM) or China Trusted Platform Module (TCM) configuration command has been entered. The system will reboot and execute the command.	Information only.

<b>Message</b>	<b>Causes</b>	<b>Corrective Actions</b>
<p>TPM or TCM configuration operation is pending. Press (I) to Ignore OR (M) to Modify to allow this change and reset the system.</p> <p>WARNING: Modifying could prevent security.</p>	<p>This message displays during system restart after a TPM or TCM configuration command has been entered. User interaction is required to proceed.</p>	<p>Enter I or M to proceed.</p>
<p>TPM or TCM failure.</p>	<p>A TPM or TCM function has failed.</p>	<p>See "Getting Help" on page 185.</p>
<p>Unable to launch System Services image. System halted!</p>	<p>System halted after &lt;F10&gt; keystroke because System Services image is either corrupted in the system firmware or has been lost due to system board replacement.</p> <p>The iDRAC6 Enterprise card flash memory may be corrupted.</p>	<p>Restart the system and update the Lifecycle Controller repository to the latest software to restore full functionality. See the Lifecycle Controller user documentation for more information.</p> <p>Restore the flash memory using the latest version on <a href="http://support.dell.com">support.dell.com</a>. See the iDRAC6 user's guide for instructions on performing a field replacement of the flash memory.</p>
<p>Unexpected interrupt in protected mode.</p>	<p>Improperly seated memory modules or faulty keyboard/mouse controller chip.</p>	<p>Reseat the memory modules. See "Troubleshooting System Memory" on page 159. If the problem persists, see "Getting Help" on page 185.</p>

<b>Message</b>	<b>Causes</b>	<b>Corrective Actions</b>
Unsupported CPU combination  Unsupported CPU stepping detected.	Processor(s) is not supported by the system.	Install a supported processor or processor combination. See "Processors" on page 125.
Unsupported DIMM detected. The following DIMM has been disabled: x	Invalid memory configuration. The system will run but with the specified memory module disabled.	Ensure that the memory modules are installed in a valid configuration. See "General Memory Module Installation Guidelines" on page 93.
Unsupported memory configuration. DIMM mismatch across slots detected: x, x, ...	Invalid memory configuration. Memory modules are mismatched in the specified slots.	Ensure that the memory modules are installed in a valid configuration. See "General Memory Module Installation Guidelines" on page 93.
Warning: A fatal error has caused system reset! Please check the system event log!	A fatal system error occurred and caused the system to reboot.	Check the SEL for information that was logged during the error. See the applicable troubleshooting section in "Troubleshooting Your System" on page 151 for any faulty components specified in the SEL.
Warning: Front Control Panel is not installed.	The control panel is not installed or has a faulty cable connection.	Install the control panel, or check the cable connections between the control panel board and the system board. See "Control Panel Assembly" on page 139.
Warning! No micro code update loaded for processor n.	Micro code update failed.	Update the BIOS. See "Getting Help" on page 185.



<b>Message</b>	<b>Causes</b>	<b>Corrective Actions</b>
Warning! Power required exceeds PSU wattage. Check PSU and system configuration.  Warning! Performance degraded. CPU and memory set to minimum frequencies to meet PSU wattage. System will reboot.	The system configuration of processor(s), memory modules, and expansion cards may not be supported by the power supplies.	If any system components were just upgraded, return the system to the previous configuration. If the system boots without this warning, then the replaced component(s) are not supported with this power supply. If Energy Smart power supplies are installed, replace them with High Output power supplies to use the components. See "Power Supplies" on page 85.
Write fault  Write fault on selected drive.	Faulty USB device, USB medium, optical drive assembly, hard drive, or hard-drive subsystem.	Replace the USB medium or device. Ensure that the USB, SAS backplane, or SATA cables are properly connected. See "Troubleshooting a USB Device" on page 152, "Troubleshooting an Internal USB Key" on page 161, and "Troubleshooting a Hard Drive" on page 164.
Incorrect memory configuration  CPU <i>n</i> .	The DIMM group for CPU <i>n</i> is incorrectly configured and caused the system to halt.	See "General Memory Module Installation Guidelines" on page 93, for memory configuration information. If the problem persists, see "Troubleshooting System Memory" on page 159.

Message	Causes	Corrective Actions
HyperTransport error caused a system reset! Please check the system event log for details!	A fatal system error occurred and caused the system to reboot.	Check the SEL for information that is logged during the error. See the applicable troubleshooting section in "Troubleshooting Your System" on page 151, for any faulty components specified in the SEL.
Warning: Following faulty DIMMs are ignored:  DIMM <i>n1 n2</i>  Total memory size is reduced.	Faulty or improperly seated memory module(s). Check both DIMMs in the same channel for a possible fault.	See "Troubleshooting Your System" on page 151.
Warning: Following faulty DIMMs are disabled:  DIMM <i>n1 n2</i>  Total memory size is reduced.	Faulty or improperly seated memory module(s). Check both DIMMs in the same channel for a possible fault.	See "Troubleshooting Your System" on page 151.
Warning: The installed memory configuration is not optimal. For more information on valid memory configurations, please see the system documentation on the technical support web site.	Invalid memory configuration. The system will run but with reduced functionality.	Ensure that the memory modules are installed in a valid configuration. See "General Memory Module Installation Guidelines" on page 93. If the problem persists, see "Troubleshooting System Memory" on page 159.

**NOTE:** For the full name of an abbreviation or acronym used in this table, see the *Glossary* at [support.dell.com/manuals](http://support.dell.com/manuals).

## Warning Messages

A warning message alerts you to a possible problem and prompts you to respond before the system continues a task. For example, before you format a diskette, a message will warn you that you may lose all data on the diskette. Warning messages usually interrupt the task and require you to respond by typing **y** (yes) or **n** (no).



**NOTE:** Warning messages are generated by either the application or the operating system. For more information, see the documentation that accompanied the operating system or application.

## Diagnostics Messages

The system diagnostic utilities may issue messages if you run diagnostic tests on your system. See "Running the System Diagnostics" on page 171 for more information about system diagnostics.

## Alert Messages

Systems management software generates alert messages for your system. Alert messages include information, status, warning, and failure messages for drive, temperature, fan, and power conditions. For more information, see the systems management software documentation at [support.dell.com/manuals](http://support.dell.com/manuals).

## Other Information You May Need



**WARNING:** See the safety and regulatory information that shipped with your system. Warranty information may be included within this document or as a separate document.

- The rack documentation included with your rack solution describes how to install your system into a rack.
- The *Getting Started Guide* provides an overview of system features, setting up your system, and technical specifications.
- Dell systems management application documentation at [support.dell.com/manuals](http://support.dell.com/manuals) provides information about installing and using the systems management software.
- Any media that ships with your system that provides documentation and tools for configuring and managing your system, including those pertaining to the operating system, system management software, system updates, and system components that you purchased with your system.



**NOTE:** Always check for updates on [support.dell.com/manuals](http://support.dell.com/manuals) and read the updates first because they often supersede information in other documents.

# Using the System Setup Program and UEFI Boot Manager

The System Setup program enables you to manage your system hardware and specify BIOS-level options. From the System Setup program, you can:

- Change the NVRAM settings after you add or remove hardware
- View the system hardware configuration
- Enable or disable integrated devices
- Set performance and power management thresholds
- Manage system security

## Choosing the System Boot Mode

The System Setup program also enables you to specify the boot mode for installing your operating system:

- BIOS boot mode (the default) is the standard BIOS-level boot interface.
- UEFI boot mode is an enhanced 64-bit boot interface based on Unified Extensible Firmware Interface (UEFI) specifications that overlays the system BIOS. See "Entering the UEFI Boot Manager" on page 64 for more information on this interface.

You must select the boot mode in the **Boot Mode** field of the "Boot Settings Screen" of the System Setup program. After specifying the boot mode, proceed to install your operating system in that mode. Thereafter, boot the system to the same boot mode (BIOS or UEFI) to access the installed operating system. Trying to boot the operating system from another boot mode causes the system to halt immediately at startup.



**NOTE:** Operating systems must be UEFI-compatible (for example, Microsoft® Windows Server® 2008 x64 version) to be installed from the UEFI boot mode. DOS and 32-bit operating systems do not support UEFI and can only be installed from the BIOS boot mode.

# Entering the System Setup Program

- 1 Turn on or restart your system.
- 2 Press <F2> immediately after you see the following message:

<F2> = System Setup

If your operating system begins to load before you press <F2>, allow the system to finish booting, and then restart your system and try again.

## Responding to Error Messages

If an error message appears while the system is booting, make a note of the message. See "System Messages" on page 38 for an explanation of the message and suggestions for correcting errors.



**NOTE:** After installing a memory upgrade, it is normal for your system to display a message the first time you start your system.

## Using the System Setup Program Navigation Keys

Keys	Action
Up arrow or <Shift><Tab>	Moves to the previous field.
Down arrow or <Tab>	Moves to the next field.
Spacebar, <+>, <->, left and right arrows	Cycles through the settings in a field. In some fields, you can also type the appropriate value.
<Esc>	Exits the System Setup program and restarts the system if any changes were made.
<F1>	Displays the System Setup program's help file.



**NOTE:** For most of the options, any changes that you make are recorded but do not take effect until you restart the system.

# System Setup Options

## Main Screen

Dell Inc. <www.dell.com> - PowerEdge R815 BIOS Version xx.yy.zz [This is DOS Setup]			
Service Tag: xxxxxxxx		Asset Tag: xxxxxxxxxxxx	
System Time ..... 00:00:00 System Date ..... DAY/MO/DATE/YR  Memory Settings ..... <Enter> Processor Settings ..... <Enter>  SATA Settings ..... <Enter>  Boot Settings ..... <Enter>  Integrated Devices ..... <Enter> PCI IRQ Assignment ..... <Enter>  Serial Communication ..... <Enter> Embedded Server Management ..... <Enter>  Power Management ..... <Enter>			
Up,Down Arrow to select	SPACE, +, - to change	ESC to exit	F1 = Help



**NOTE:** The options for the System Setup program change based on the system configuration.



**NOTE:** The System Setup program defaults are listed under their respective options in the following sections, where applicable.

Option	Description
System Time	Sets the time on the system's internal clock.
System Date	Sets the date on the system's internal calendar.
Memory Settings	Displays information related to installed memory. See "Memory Settings Screen" on page 57.

<b>Option</b>	<b>Description</b>
Processor Settings	Displays information related to processors (speed, cache size, and so on). See "Processor Settings Screen" on page 58.
SATA Settings	Displays a screen to enable or disable the integrated SATA controller and ports. See "SATA Settings Screen" on page 59.
Boot Settings	Displays a screen to specify the boot mode (BIOS or UEFI). For BIOS boot mode, you can also specify the boot devices. See "Boot Settings Screen" on page 59.
Integrated Devices	Displays a screen to enable or disable integrated device controllers and ports, and to specify related features and options. See "Integrated Devices Screen" on page 60.
PCI IRQ Assignment	Displays a screen to change the IRQ assigned to each of the integrated devices on the PCI bus, and any installed expansion card that requires an IRQ. See "PCI IRQ Assignments Screen" on page 61.
Serial Communication	Displays a screen to enable or disable the serial ports and specify related features and options. See "Serial Communication Screen" on page 61.
Power Management	Enables you to manage power usage of the processor(s), fans, and memory modules with preconfigured or customized settings. See "Power Management Screen" on page 62.
System Security	Displays a screen to configure the system password and setup password features. See "System Security Screen" on page 63, "Using the System Password" on page 67, and "Using the Setup Password" on page 69 for more information.
Keyboard NumLock (On default)	Determines whether your system starts up with the NumLock mode activated on 101- or 102-key keyboards (does not apply to 84-key keyboards).



Option	Description
Report Keyboard Errors (Report default)	Enables or disables reporting of keyboard errors during the POST. Select <b>Report</b> for host systems that have keyboards attached. Select <b>Do Not Report</b> to suppress all error messages relating to the keyboard or keyboard controller during POST. This setting does not affect the operation of the keyboard itself if a keyboard is attached to the system.
F1/F2 Prompt on Error (Enabled default)	Enables the system to halt on errors during POST, which allows the user to observe events that may scroll by unnoticed during normal POST. The user can press <F1> to continue or <F2> to enter the System Setup program.   <b>CAUTION: When setting this option to Disabled, the system does not halt if an error occurs during POST. Any critical errors are displayed and logged in the system event log.</b>

## Memory Settings Screen

Option	Description
System Memory Size	Displays the amount of system memory.
System Memory Type	Displays the type of system memory.
System Memory Speed	Displays the system memory speed.
Video Memory	Displays the amount of video memory.
System Memory Testing (Enabled default)	Specifies whether system memory tests are run at system boot. Options are <b>Enabled</b> and <b>Disabled</b> .
Redundant Memory (Disabled default)	Specifies whether redundant memory is enabled on the system. Options are <b>Enabled</b> and <b>Disabled</b> .
Node Interleaving (Disabled default)	If this field is <b>Enabled</b> , memory interleaving is supported if a symmetric memory configuration is installed.

## Processor Settings Screen

Option	Description
64-bit	Specifies if the processor(s) support 64-bit extensions.
Core Speed	Displays the processor clock speed.
Bus Speed	Displays the processor bus speed.
Hyper Transport Technology ( <b>HT3</b> default)	Displays the HyperTransport link speed, and depending upon the system, this field may be read-only. HT3 capable systems ship with HT3 by default.
HT Assist ( <b>Enabled</b> default)	Enables or disables the HT Assist.
CPU Virtualization Technology ( <b>Enabled</b> default)	<b>Enabled</b> permits virtualization software to use the virtualization technology incorporated in the processor. <b>NOTE:</b> Disable this feature if your system does not run virtualization software.
DRAM Prefetcher ( <b>Enabled</b> default)	Enables or disables the DRAM prefetcher.
Hardware Prefetch Training on Software Prefetch	Enables or disables the Hardware prefetcher training on software prefetcher.
Hardware Prefetcher ( <b>Enabled</b> default)	Enables or disables the hardware prefetcher.
Execute Disable ( <b>Enabled</b> default)	Enables or disables <b>Execute Disable Memory Protection Technology</b> .
Number of Cores per Processor ( <b>All</b> default)	Controls the number of enabled cores in each processor.
C1E ( <b>Disabled</b> default)	When set to <b>Enabled</b> , the processor(s) can switch to a minimum performance state when idle.
Processor X Family-Model-Stepping	Displays the family and model number of each processor. A submenu displays the core speed, the amount of cache memory, and the number of cores of the processor(s).

## SATA Settings Screen

Option	Description
Embedded SATA (Off default)	<b>ATA Mode</b> enables the integrated SATA controller. <b>Off</b> disables the controller.
Port A (Off default)	<b>Auto</b> enables BIOS support for the device attached to SATA port A. <b>Off</b> disables BIOS support for the device.

## Boot Settings Screen

Option	Description
Boot Mode (BIOS default)	 <b>CAUTION: Switching the boot mode could prevent the system from booting if the operating system was not installed in the same boot mode.</b>  If the operating system supports Unified Extensible Firmware Interface, you can set this option to <b>UEFI</b> . Setting this field to <b>BIOS</b> allows compatibility with non-UEFI operating systems.  <b>NOTE:</b> Setting this field to <b>UEFI</b> disables the <b>Boot Sequence</b> , <b>Hard-Disk Drive Sequence</b> , and <b>USB Flash Drive Emulation Type</b> fields.
Boot Sequence	If <b>Boot Mode</b> is set to <b>BIOS</b> , this field tells the system where the operating system files needed for startup are located. If <b>Boot Mode</b> is set to <b>UEFI</b> , you can access the UEFI boot manager utility by rebooting the system and pressing <F11> when prompted to do so.
Hard-Disk Drive Sequence	Determines the order in which the BIOS attempts to boot from hard drives in the system during system startup.
USB Flash Drive Emulation Type	Determines the emulation type for a USB flash drive. If <b>Boot Mode</b> is set to <b>UEFI</b> , this field is disabled.
Boot Sequence Retry (Disabled default)	If this field is enabled and the system has failed to boot, the system reattempts to boot after 30 seconds.

## Integrated Devices Screen

Option	Description
Integrated SAS Controller ( <b>Enabled</b> default)	Enables or disables the integrated SAS controller.
User Accessible USB Ports ( <b>All Ports On</b> default)	Enables or disables the user accessible USB ports. Options are <b>All Ports On</b> , <b>Only Back Ports On</b> , and <b>All Ports Off</b> .
Internal USB Port ( <b>On</b> default)	Enables or disables the internal USB port.
Internal SD Card Port ( <b>On</b> default)	Enables or disables the internal SD card port.
Redundancy ( <b>Disabled</b> default)	Enables or disables the mirror mode for Internal Dual SD Modules (if installed).
Embedded NIC1 and NIC2 ( <b>Enabled</b> default)	Enables or disables the operating system interface of the embedded NICs. The NICs can also be accessed through the system's management controller.
Embedded Gb NICx ( <b>Enabled</b> default)	Enables or disables the integrated NIC. Options are <b>Enabled</b> and <b>Enabled with PXE</b> . PXE support allows the system to boot from the network.
MAC Address	Displays the MAC address for the integrated 10/100/1000 NIC.
OS Watchdog Timer ( <b>Disabled</b> default)	Aids recovery of the operating system, if your system stops responding. If set to <b>Enabled</b> , the operating system is allowed to initialize the timer.
Embedded Video Controller ( <b>Enabled</b> default)	Enables/disables BIOS support for the Embedded Video Controller.

## PCI IRQ Assignments Screen

Option	Description
<PCIe device>	Use the <+> and <-> keys to manually select an IRQ for a given device, or select <b>Default</b> to allow the BIOS to select an IRQ value at system startup.

## Serial Communication Screen

Option	Description
Serial Communication (On without Console Redirection default)	Selects whether the serial communication devices (Serial Device 1 and Serial Device 2) are enabled in BIOS. BIOS console redirection can also be enabled and the port address to be used can be specified.  Options are <b>On without Console Redirection</b> , <b>On with Console Redirection via COM1</b> , <b>On with Console Redirection via COM2</b> , and <b>Off</b> .
Serial Port Address (Serial Device 1=COM1, Serial Device2=COM2 default)	Sets the serial port addresses for the two serial devices. <b>NOTE:</b> Only Serial Device 2 can be used for Serial Over LAN (SOL). To use console redirection by SOL, configure the same port address for console redirection and the serial device.
External Serial Connector (Serial Device1 default)	Specifies whether Serial Device 1, Serial Device 2, or Remote Access Device has access to the external serial connector. <b>NOTE:</b> Only Serial Device 2 can be used for Serial Over LAN (SOL). To use console redirection by SOL, configure the same port address for console redirection and the serial device.
Failsafe Baud Rate (115200 default)	Displays the failsafe baud rate used for console redirection. BIOS attempts to determine the baud rate automatically. This failsafe baud rate is used only if the attempt fails. This rate should not be adjusted.
Remote Terminal Type (VT 100/VT220 default)	Sets the remote console terminal type, either VT100/VT220 or ANSI.
Redirection After Boot (Enabled default)	Enables or disables BIOS console redirection when the operating system is loaded.

## Power Management Screen

Option	Description
Power Management (Active Power Controller default)	<p>Options are <b>OS Control</b>, <b>Active Power Controller</b>, <b>Custom</b>, or <b>Maximum Performance</b>. For all but the <b>Custom</b> setting, the BIOS pre-configures the power settings on this screen as follows:</p> <ul style="list-style-type: none"> <li>• <b>OS Control</b> sets the processor power to <b>OS DBPM</b>, the fan power to <b>Minimum Power</b>, and the memory power to <b>Maximum Performance</b>. In this setting, all processor performance information is passed from the system BIOS to the operating system for control. The operating system sets the processor performance based on processor utilization.</li> <li>• <b>Active Power Controller</b> sets the processor power to <b>System DBPM</b>, the fan power to <b>Minimum Power</b>, and the memory power to <b>Maximum Performance</b>. The BIOS sets the processor performance based on processor utilization.</li> <li>• <b>Maximum Performance</b> sets all fields to <b>Maximum Performance</b>.</li> </ul>
CPU Power and Performance Management	<p>If you select <b>Custom</b>, you can configure each option independently.</p> <p>Options are <b>OS DBPM</b>, <b>System DBPM</b>, <b>Maximum Performance</b>, or <b>Minimum Power</b>.</p>
Fan Power and Performance Management	<p>Options are <b>Maximum Performance</b> or <b>Minimum Power</b>.</p>
Memory Power and Performance Management	<p>Options are <b>Maximum Performance</b>, a specified frequency, or <b>Minimum Power</b>.</p>

## System Security Screen

Option	Description
System Password	<p>Displays the current status of the password security feature and allows a new system password assignment and verification.</p> <p><b>NOTE:</b> See Using the "Using the System Password" on page 67 for more information.</p>
Setup Password	<p>Restricts access to the System Setup program by using a setup password.</p> <p><b>NOTE:</b> See "Using the System Password" on page 67 for more information.</p>
Password Status (Unlocked default)	<p>When <b>Setup Password</b> is assigned and this field is <b>Locked</b>, the system password cannot be changed or disabled at system start-up.</p> <p>See "Using the System Password" on page 67 for more information.</p>
Power Button (Enabled default)	<p>If <b>Enabled</b>, the power button can turn the system's power off and on. On an ACPI-compliant operating system, the system performs an orderly shutdown before power is turned off.</p> <p>When <b>Disabled</b>, the button can only turn on system power.</p>
NMI Button (Disabled default)	<p> <b>CAUTION: Use the NMI button only if directed to do so by qualified support personnel or by the operating system's documentation. Pressing this button halts the operating system and displays a diagnostic screen.</b></p> <p>Enables or disables the NMI feature.</p>
AC Power Recovery (Last default)	<p>Determines how the system reacts when power is restored. If set to <b>Last</b>, the system returns to the last power state. <b>On</b> turns on the system after power is restored. <b>Off</b> allows the system to remain off after power is restored.</p>

Option	Description
AC Power Recovery Delay	Determines when the system restarts after power is restored. Options are <b>Immediate</b> , <b>Random</b> (a random value of 30 to 240 seconds), or a user-defined value of 30 to 240 seconds.
User Defined Delay	The delay defined by the user.

## Exit Screen

Press <Esc> to exit the System Setup program; the **Exit** screen displays:

- Save Changes and Exit
- Discard Changes and Exit
- Return to Setup

## Entering the UEFI Boot Manager

 **NOTE:** Operating systems must be 64-bit UEFI-compatible (for example, Microsoft Windows Server 2008 x64 version) to be installed from the UEFI boot mode. DOS and 32-bit operating systems can only be installed from the BIOS boot mode.

 **NOTE:** The Boot Mode must be set to UEFI in the System Setup program to access the UEFI Boot Manager.

The UEFI Boot Manager enables you to:

- Add, delete, and arrange boot options
- Access the System Setup program and BIOS-level boot options without rebooting

**1** Turn on or restart your system.

**2** Press <F11> after you see the following message:

<F11> = UEFI Boot Manager

 **NOTE:** The system does not respond until the USB keyboard is active.

If your operating system begins to load before you press <F11>, allow the system to finish booting, and then restart your system and try again.



## Using the UEFI Boot Manager Navigation Keys

Keys	Action
Up arrow	Moves to and highlights the previous field.
Down arrow	Moves to and highlights the next field.
Spacebar, <Enter>, <+>, <->	Cycles through the settings in a field.
<Esc>	Refreshes the UEFI Boot Manager screen, or returns to the UEFI Boot Manager screen from the other program screens.
<F1>	Displays the UEFI Boot Manager help file.

## UEFI Boot Manager Screen

Option	Description
Continue	The system attempts to boot to devices starting with the first item in the boot order. If the boot attempt fails, the system continues with the next item in the boot order until the boot is successful or no more boot options are found.
<Boot options>	Displays the list of available boot options (marked with asterisks). Select the boot option you wish to use and press Enter. <b>NOTE:</b> If you hot-add a boot device, press <ESC> to refresh the list of boot options.
UEFI Boot Settings	Enables you to add, delete, enable, or disable boot options; change boot order; or execute a one-time boot option.
System Utilities	Enables you to access the System Setup program, System Services (Unified Server Configurator [USC]), Diagnostics, and BIOS-level boot options.

## UEFI Boot Settings Screen

Option	Description
Add Boot Option	Adds a new boot option.
Delete Boot Option	Deletes an existing boot option.
Enable/Disable Boot Option	Disables and enables a boot option in the boot option list.
Change Boot Order	Changes the order of the boot option list.
One-Time Boot From File	Sets a one-time boot option not included in the boot option list.

## System Utilities Screen

Option	Description
System Setup	Accesses the System Setup program without rebooting.
System Services	Restarts the system and access the Lifecycle Controller, which allows you to run utilities such as system diagnostics.
BIOS Boot Manager	Accesses the BIOS-level boot options list without rebooting. This option enables you to conveniently switch to BIOS boot mode if you need to boot to a device with a non-UEFI operating system, such as a bootable DOS media with diagnostics software.
Reboot System	Restarts the system.

## System and Setup Password Features



**NOTE:** For a forgotten password, see "Disabling a Forgotten Password" on page 183.

Your system is shipped without the system password feature enabled. Operate the system only with system password protection.



**CAUTION:** The password features provide a basic level of security for the data on your system.



**CAUTION:** Anyone can access the data stored on your system if the system is running and unattended.

## Using the System Password

When a system password is assigned, the system prompts for the password during start up.

### Assigning a System Password

Before assigning a system password, enter the System Setup program and check the **System Password** option.

When a system password is assigned, **System Password** is **Enabled**. If **Password Status** is **Unlocked**, you can change the system password. If **Locked**, you cannot change the system password. Disabling the password jumper on the system board sets **System Password** to **Disabled**, and you cannot change or enter a new system password.

When a system password is not assigned and the password jumper on the system board is in the enabled position, **System Password** is **Not Enabled** and **Password Status** is **Unlocked**.

To assign a system password:

- 1 Verify that **Password Status** is **Unlocked**.
- 2 Highlight the **System Password** option and press <Enter>.
- 3 Type your new system password.

You can use up to 32 characters in your password.

As you type, placeholders appear in the field.

The password assignment is not case-sensitive. Certain key combinations are invalid and if you enter one, the system beeps. To erase a character, press <Backspace> or the left-arrow key.



**NOTE:** To escape from the field without assigning a system password, press <Enter> to move to another field, or press <Esc> prior to completing step 5.

- 4 Press <Enter>.

- 5 To confirm your password, type it a second time and press <Enter>. **System Password** changes to **Enabled**. Exit the System Setup program and begin using your system.
- 6 Either reboot the system now for the password protection to take effect or continue working.



**NOTE:** Password protection does not take effect until the system reboots.

### Using Your System Password to Secure Your System



**NOTE:** If you have assigned a setup password (see "Using the Setup Password" on page 69), the system accepts your setup password as an alternate system password.

When **Password Status** is **Unlocked**, you have the option to leave the password security enabled or to disable password security.

To leave the password security enabled:

- 1 Turn on or reboot your system by pressing <Ctrl><Alt><Delete>.
- 2 Type your password and press <Enter>.

To disable the password security:

- 1 Turn on or reboot your system by pressing <Ctrl><Alt><Delete>.
- 2 Type your password and press <Ctrl><Enter>.

When **Password Status** is **Locked**, type the password and press <Enter> when prompted at reboot.

If an incorrect system password is entered, the system displays a message and prompts you to re-enter your password. You have three attempts to enter the correct password. After the third unsuccessful attempt, the system displays an error message that the system has halted and shuts down.

Even after you shut down and restart the system, the error message continues to be displayed until the correct password is entered.



**NOTE:** You can use the **Password Status** option in conjunction with the **System Password** and **Setup Password** options to protect your system from unauthorized changes.

## Deleting or Changing an Existing System Password

- 1 Enter the System Setup program and select the **System Security**.
- 2 Highlight **Setup Password**, press <Enter> to access the setup password window. Press <Enter> twice to clear the existing setup password.  
The setting changes to **Not Enabled**.
- 3 If you want to assign a new setup password, perform the steps in "Assigning a Setup Password" on page 69.

## Using the Setup Password

### Assigning a Setup Password

You can assign a setup password only when the **Setup Password** is **Not Enabled**. To assign a setup password, highlight the **Setup Password** option and press the <+> or <-> key. The system prompts you to enter and verify the password.



**NOTE:** The setup password can be the same as the system password. If the two passwords are different, the setup password can be used as an alternate system password. The system password cannot be used in place of the setup password.

You can use up to 32 characters in your password.

As you type, placeholders appear in the field.

The password assignment is not case-sensitive. Certain key combinations are invalid and if you enter one, the system beeps. To erase a character, press <Backspace> or the left-arrow key.

When you verify the password, the **Setup Password** changes to **Enabled**. The next time you enter the System Setup program, the system prompts you for the setup password.

A change to the **Setup Password** option becomes effective immediately (restarting the system is not required).

## Operating With a Setup Password Enabled

If **Setup Password** is **Enabled**, you must enter the correct setup password before modifying most of the System Setup options.

If you do not enter the correct password in three attempts, the system lets you view, but not modify, the System Setup screens. The following options are exceptions: If **System Password** is not **Enabled** and is not locked through the **Password Status** option, you can assign a system password. You cannot disable or change an existing system password.



**NOTE:** You can use the **Password Status** option in conjunction with the **Setup Password** option to protect the system password from unauthorized changes.

## Deleting or Changing an Existing Setup Password

- 1 Enter the System Setup program and select the **System Security**.
- 2 Highlight **Setup Password**, press <Enter> to access the setup password window. Press <Enter> twice to clear the existing setup password.  
The setting changes to **Not Enabled**.
- 3 If you want to assign a new setup password, perform the steps in "Assigning a Setup Password" on page 69.

## Embedded System Management

The Lifecycle Controller is an embedded utility that enables systems management tasks from an embedded environment throughout the server's lifecycle.

Lifecycle Controller can be started during the boot sequence and can function independently of the operating system.



**NOTE:** Certain platform configurations may not support the full set of features provided by the Lifecycle Controller.

For more information about setting up the Lifecycle Controller, configuring hardware and firmware, and deploying the operating system, see the Lifecycle Controller documentation on the Dell Support website at [support.dell.com/manuals](http://support.dell.com/manuals).

# iDRAC6 Configuration Utility

The iDRAC6 Configuration Utility is a pre-boot configuration environment that allows you to view and set parameters for the iDRAC6 and for the managed server.

The iDRAC6 Configuration Utility provides the following features:

- Enables fault logging and SNMP alerting
- Provides access to system event log and sensor status
- Functions independently of the system's operating system

In addition the iDRAC6 Configuration Utility enables you to:

- Configure, enable, or disable the iDRAC6 local area network through the dedicated iDRAC6 Enterprise card port or the embedded NIC1.
- Enable or disable IPMI over LAN
- Enable a LAN Platform Event Trap (PET) destination
- Attach or detach the Virtual Media devices
- Change the administrative user name and password and manage user privileges
- View System Event Log (SEL) messages or clear messages from the log
- Reset iDRAC6 settings to default

For additional information on using iDRAC6, see the documentation for iDRAC6 and systems management applications.

## Entering the iDRAC6 Configuration Utility

- 1 Turn on or restart your system.
- 2 Press <Ctrl><E> when prompted during POST.

If your operating system begins to load before you press <Ctrl><E>, allow the system to finish booting, and then restart your system and try again.





# Installing System Components

## Recommended Tools

You may need the following items to perform the procedures in this section:

- Key to the system keylock
- #1 and #2 Phillips screwdrivers
- T8 and T10 Torx drivers
- Wrist grounding strap

## Inside the System



**WARNING:** Whenever you need to lift the system, get others to assist you. To avoid injury, do not attempt to lift the system by yourself.



**CAUTION:** Many repairs may only be done by a certified service technician. You should only perform troubleshooting and simple repairs as authorized in your product documentation, or as directed by the online or telephone service and support team. Damage due to servicing that is not authorized by Dell is not covered by your warranty. Read and follow the safety instructions that came with the product.



**NOTE:** It is recommended that you always use a static mat and static strap while working on components in the interior of the system.

**Figure 3-1. Inside the System**

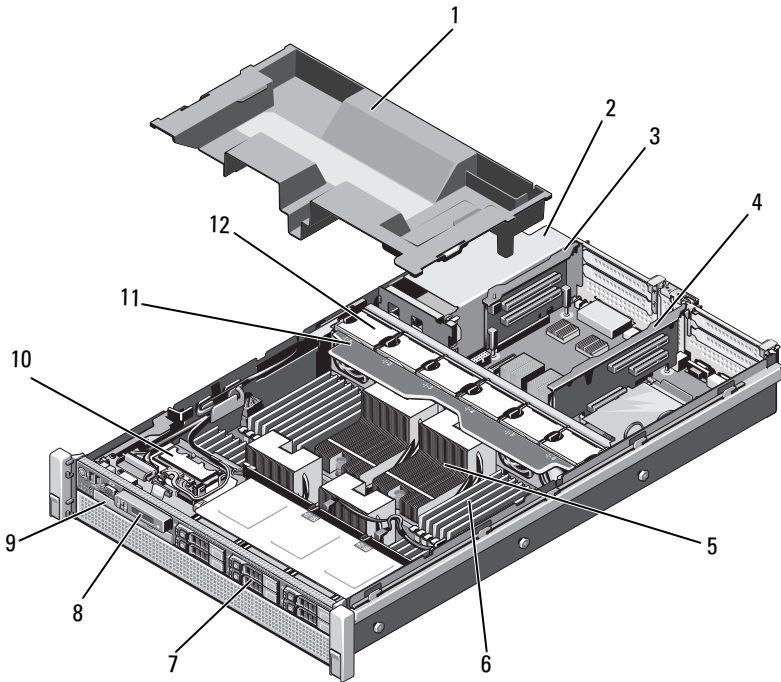

- |    |                          |    |                          |
|----|--------------------------|----|--------------------------|
| 1  | cooling shroud           | 2  | power supply bays (2)    |
| 3  | expansion card riser 2   | 4  | expansion card riser 1   |
| 5  | heat sinks (2 or 4)      | 6  | memory modules (8 to 32) |
| 7  | hard drives (up to 6)    | 8  | control panel            |
| 9  | optical drive (optional) | 10 | SD module                |
| 11 | cooling fan assembly     | 12 | cooling fans (6)         |

# Front Bezel (Optional)

## Removing the Front Bezel

- 1 Unlock the keylock at the left end of the bezel.
- 2 Lift up the release latch next to the keylock.
- 3 Rotate the left end of the bezel away from the front panel.
- 4 Unhook the right end of the bezel and pull the bezel away from the system. See Figure 3-2.

**Figure 3-2. Removing and Installing the Front Bezel**

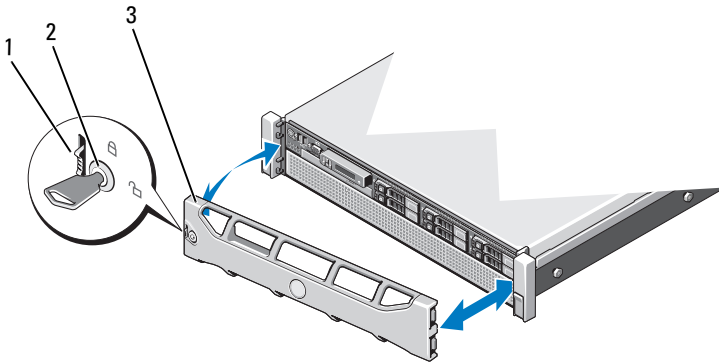

- 1 release latch
- 3 front bezel

2 key lock

## Installing the Front Bezel

- 1 Hook the right end of the bezel onto the chassis.
- 2 Fit the free end of the bezel onto the chassis.
- 3 Secure the bezel with the keylock. See Figure 3-2.

# Opening and Closing the System



**WARNING:** Whenever you need to lift the system, get others to assist you. To avoid injury, do not attempt to lift the system by yourself.



**CAUTION:** Many repairs may only be done by a certified service technician. You should only perform troubleshooting and simple repairs as authorized in your product documentation, or as directed by the online or telephone service and support team. Damage due to servicing that is not authorized by Dell is not covered by your warranty. Read and follow the safety instructions that came with the product.



**NOTE:** It is recommended that you always use a static mat and static strap while working on components in the interior of the system.

## Opening the System

- 1 Turn off the system and attached peripherals, and disconnect the system from the electrical outlet and peripherals.
- 2 Rotate the latch release lock counter clockwise to the unlocked position. See Figure 3-3.
- 3 Lift the latch and slide the cover toward the back of the system.
- 4 Grasp the cover on both sides and lift the cover away from the system. See Figure 3-3.

**Figure 3-3. Opening and Closing the System**

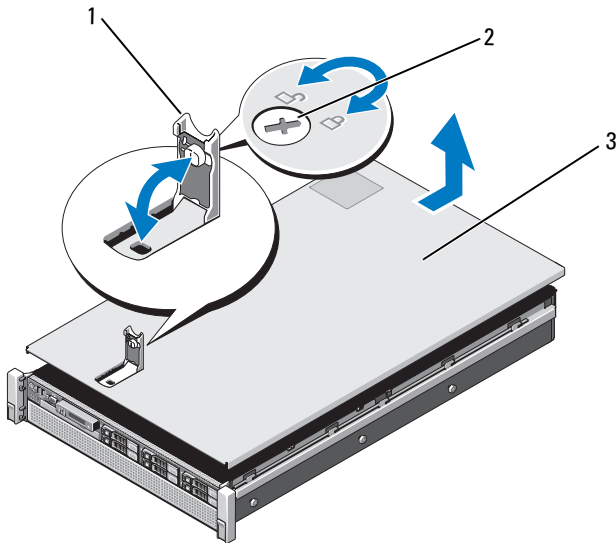

- 1 latch
- 3 cover

- 2 latch release lock

### Closing the System

- 1 Place the cover onto the chassis and offset it slightly toward the back of the system, so that the slots on the sides of the cover fit into the corresponding hooks on the sides of the chassis. See Figure 3-3.

**NOTE:** To close the system properly, ensure that the tabs on the cooling shroud are seated in the slots on the chassis. See Figure 3-9.

- 2 Slide the cover toward the front of the chassis till it snaps in position.
- 3 Push down the latch to secure the cover into the closed position.
- 4 Rotate the latch release lock in a clockwise direction to secure the cover.
- 5 Reconnect the system to its electrical outlet and turn the system on, including any attached peripherals.

# Hard Drives

All drives connect to the system board through the SAS/SATA backplane board mounted on the front-chassis assembly. Hard drives are supplied in hot-swappable drive carriers that fit in the hard-drive bays.

 **CAUTION:** Before attempting to remove or install a drive while the system is running, see the documentation for the SAS controller card to ensure that the host adapter is configured correctly to support hot-swap drive removal and installation.

 **CAUTION:** Do not turn off or reboot your system while the drive is being formatted. Doing so can cause a drive failure.

 **NOTE:** Use only drives that have been tested and approved for use with the SAS/SATA backplane board.

When you format a hard drive, allow enough time for the formatting to be completed. Be aware that high-capacity hard drives can take a number of hours to format.

## Removing a Hard-Drive Blank

 **CAUTION:** To maintain proper system cooling, all empty hard-drive bays must have drive blanks installed.

- 1 If installed, remove the front bezel. See "Removing the Front Bezel" on page 75.
- 2 Grasp the front of the hard-drive blank, press the release button and slide the blank out until it is free of the drive bay. See Figure 3-4.

**Figure 3-4. Removing and Installing a Hard-Drive Blank**

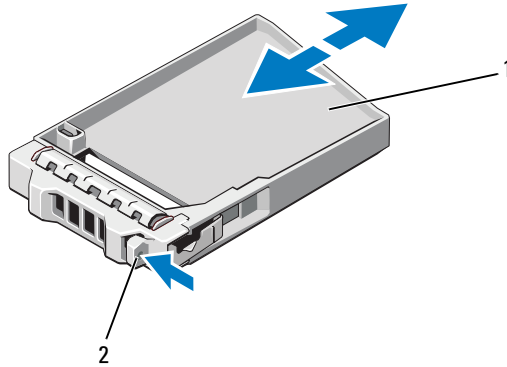

1 hard-drive blank

2 release button

### **Installing a Hard-Drive Blank**

- 1** If installed, remove the front bezel. See "Removing the Front Bezel" on page 75.
- 2** Insert the drive blank into the drive bay until the release button clicks into place.
- 3** If applicable, replace the front bezel. See "Installing the Front Bezel" on page 75.

## Removing a Hard-Drive Carrier



**CAUTION: Ensure that your operating system supports hot-swap drive installation. See the documentation supplied with the operating system.**

- 1 If installed, remove the front bezel. See "Removing the Front Bezel" on page 75.
- 2 From the management software, prepare the drive for removal. Wait until the hard-drive indicators on the drive carrier signal that the drive can be removed safely. See your controller documentation for information about hot-swap drive removal.

If the drive has been online, the green activity/fault indicator flashes as the drive is powered down. When the drive indicators are off, the drive is ready for removal.

- 3 Press the release button on the front of the hard-drive carrier and open the handle.

The hard-drive carrier handle opens.

- 4 Slide the hard-drive carrier out until it is free of the drive bay. See Figure 3-5.



**CAUTION: To maintain proper system cooling, all empty hard-drive bays must have drive blanks installed.**

- 5 Insert a drive blank in the empty drive bay. See "Installing a Hard-Drive Blank" on page 79.
- 6 If applicable, replace the front bezel. See "Installing the Front Bezel" on page 75.



**Figure 3-5. Removing and Installing a Hard-Drive Carrier**

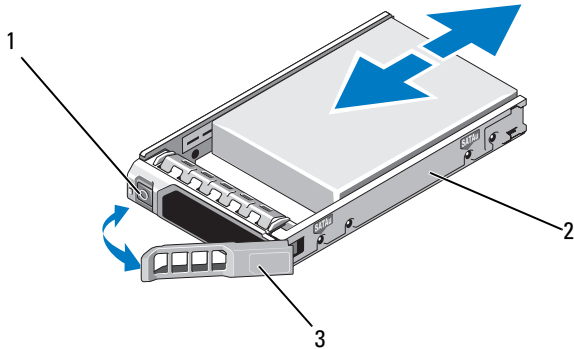

- 1 release button
- 2 hard-drive carrier
- 3 hard-drive carrier handle

### Installing a Hard-Drive Carrier

**CAUTION:** Use only hard drives that have been tested and approved for use with the SAS/SATA backplane.

**CAUTION:** When installing a hard drive, ensure that the adjacent drives are fully installed. Inserting a hard-drive carrier and attempting to lock its handle next to a partially installed carrier can damage the partially installed carrier's shield spring and make it unusable.

**CAUTION:** Ensure that your operating system supports hot-swap drive installation. See the documentation supplied with your operating system.

- 1 If installed, remove the front bezel. See "Removing the Front Bezel" on page 75.
- 2 If a drive blank is present in the bay, remove it. See "Removing a Hard-Drive Blank" on page 78.
- 3 Press the release button on the front of the hard-drive carrier and open the handle.
- 4 Insert the hard-drive carrier into the drive bay until the carrier contacts the backplane.
- 5 Close the hard-drive carrier handle to lock the drive in place.

## Removing a Hard Drive From a Hard-Drive Carrier

Remove the screws from the slide rails on the hard-drive carrier and separate the hard drive from the carrier. See Figure 3-6.

**Figure 3-6. Removing and Installing a Hot-Swap Hard Drive Into a Hard-Drive Carrier**

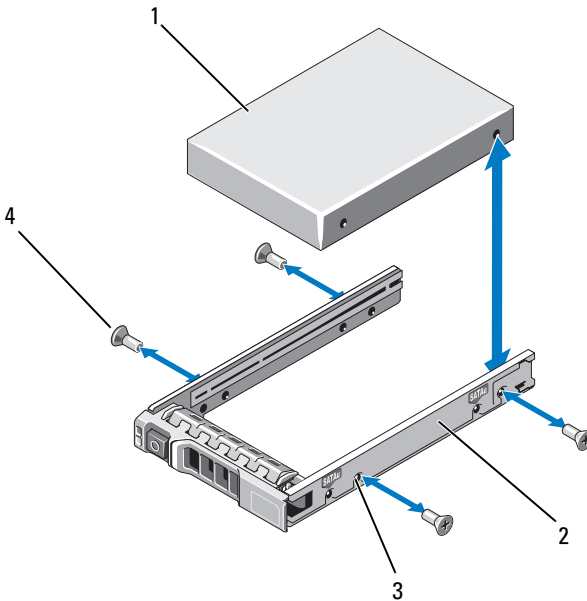

- |   |                     |   |                    |
|---|---------------------|---|--------------------|
| 1 | hard drive          | 2 | hard-drive carrier |
| 3 | SAS/SATA screw hole | 4 | screws (4)         |

## Installing a Hard Drive Into a Hard-Drive Carrier

- 1 Insert the hard drive into the hard-drive carrier with the connector end of the drive at the rear. See Figure 3-6.
- 2 Align the screw holes on the hard drive with the back set of holes on the hard-drive carrier.
- 3 Attach the four screws to secure the hard drive to the hard-drive carrier.

# Optical Drive

Your system is provided with an optional slimline SATA DVD-ROM or DVD+/-RW optical drive.

 **NOTE:** DVD devices are data only.

## Removing an Optical Drive



**CAUTION:** Many repairs may only be done by a certified service technician. You should only perform troubleshooting and simple repairs as authorized in your product documentation, or as directed by the online or telephone service and support team. Damage due to servicing that is not authorized by Dell is not covered by your warranty. Read and follow the safety instructions that came with the product.

- 1 If installed, remove the front bezel. See "Removing the Front Bezel" on page 75.
- 2 Turn off the system, including any attached peripherals, and disconnect the system from its electrical outlet.
- 3 Open the system. See "Opening the System" on page 76.
- 4 Disconnect the power/data cable from the back of the drive.

Note the routing of the power/data cable inside the system as you remove them from the system board and the drive. Route these cables properly when you replace them to prevent them from being pinched or crimped. For more information, see "Front-Chassis Assembly" on page 90.

- 5 To remove the drive, press down and push the blue release tab toward the front of the system. See Figure 3-7.
- 6 Slide the optical drive out of the system until it is free of the drive bay.
- 7 If you are not installing a new optical drive, install the optical drive insert.
- 8 Close the system. See "Closing the System" on page 77.
- 9 Reconnect the system to its electrical outlet and turn the system on, including any attached peripherals.
- 10 If applicable, replace the front bezel. See "Installing the Front Bezel" on page 75.

**Figure 3-7. Removing and Installing the Optical Drive**

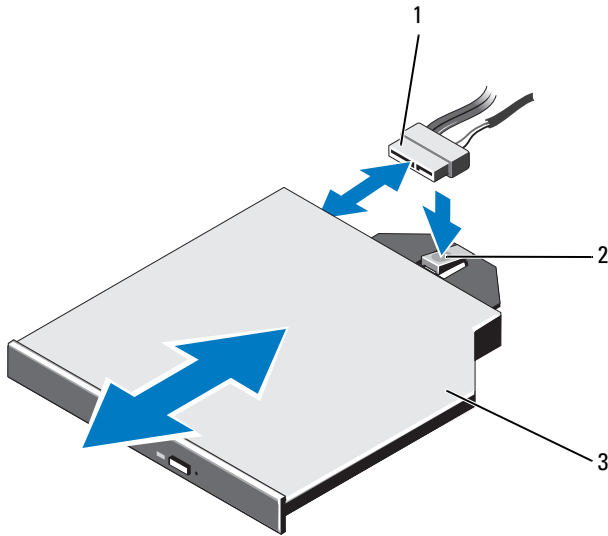

- 1 power/data cable
- 2 release tab
- 3 optical drive

### Installing an Optical Drive

**⚠ CAUTION:** Many repairs may only be done by a certified service technician. You should only perform troubleshooting and simple repairs as authorized in your product documentation, or as directed by the online or telephone service and support team. Damage due to servicing that is not authorized by Dell is not covered by your warranty. Read and follow the safety instructions that came with the product.

- 1 If installed, remove the front bezel. See "Removing the Front Bezel" on page 75.
- 2 Turn off the system, including any attached peripherals, and disconnect the system from its electrical outlet.
- 3 Open the system. See "Opening the System" on page 76.
- 4 Slide the optical drive into the optical drive bay until the blue release tab snaps into place. See Figure 3-7.

- 5 Connect the power/data cable to the back of the drive and to the system board.  
Route the cable properly inside the system to prevent it from being pinched or crimped. For more information, see "Front-Chassis Assembly" on page 90.
- 6 Close the system. See "Closing the System" on page 77.
- 7 Reconnect the system to its electrical outlet and turn the system on, including any attached peripherals.
- 8 If applicable, replace the front bezel. See "Installing the Front Bezel" on page 75.

## Power Supplies

Your system supports two hot-swappable 1100 W power supplies.

If two power supplies are installed, the second power supply provides, power redundancy. In a redundant mode, the system distributes the power load across both power supplies to maximize efficiency. When a power supply is removed with the system powered on, the full power load is picked up by the second power supply. Table 3-1 lists the power supply redundancy modes.

**Table 3-1. Power Supply Redundancy Modes**

<b>Number of Power Supplies</b>	<b>Redundancy Mode</b>	<b>System Configuration</b>
1	1+0	Nonredundant configuration
2	1+1	Redundant configuration

## Removing a Power Supply



**CAUTION:** The system requires one power supply for normal operation. On power-redundant systems, remove and replace only one power supply at a time in a system that is powered on.

- 1 Disconnect the power cable from the power source.
- 2 Disconnect the power cable from the power supply and remove the Velcro straps that bundle and secure the system cables.



**NOTE:** You may have to unlatch and lift the optional cable management arm if it interferes with power-supply removal. For information about the cable management arm, see the system's rack documentation.

- 3 Press the release latch and pull the power supply out to release it from the power distribution board and clear the chassis.

If you are permanently removing the power supply, you must install a power supply blank to ensure proper system cooling. See "Installing the Power Supply Blank" on page 87.

**Figure 3-8. Removing and Installing a Power Supply**

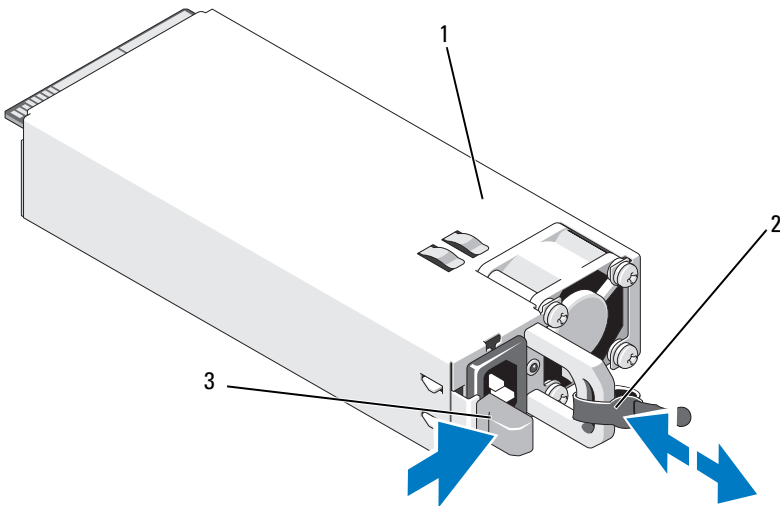

- 1 power supply
- 3 release latch

2 velcro strap

## Installing a Power Supply

- 1 Verify that the power supplies are the same type and have the same maximum output power.



**NOTE:** The maximum output power (shown in watts) is listed on the power supply label.

- 2 If applicable, remove the power supply blank. See "Removing the Power Supply Blank" on page 87.
- 3 Slide the new power supply into the chassis until the power supply is fully seated and the release latch snaps into place. See Figure 3-8.



**NOTE:** If you unlatched the cable management arm in step 1 of the previous procedure, relatch it. For information about the cable management arm, see the system's rack documentation.

- 4 Connect the power cable to the power supply and plug the cable into a power outlet.



**CAUTION:** When connecting the power cable, secure the cable with the Velcro strap.



**NOTE:** When installing, hot-swapping, or hot-adding a new power supply in a system, allow several seconds for the system to recognize the power supply and determine its status. The power-supply status indicator turns green to signify that the power supply is functioning properly.

## Removing the Power Supply Blank

If you are installing a power supply, remove the power supply blank by pulling outward on the blank.



**CAUTION:** To ensure proper system cooling, the power supply blank must be installed in power supply bay PS2 in a non-redundant configuration. Remove the power supply blank only if you are installing a second power supply.

## Installing the Power Supply Blank



**NOTE:** Install the power supply blank only in power supply bay 2.

To install the power supply blank, align the blank with the power supply bay and insert the blank into the chassis until it clicks into place.

# Cooling Shroud

The cooling shroud covers the memory modules and provides air flow to the system.

## Removing the Cooling Shroud

 **CAUTION: Many repairs may only be done by a certified service technician. You should only perform troubleshooting and simple repairs as authorized in your product documentation, or as directed by the online or telephone service and support team. Damage due to servicing that is not authorized by Dell is not covered by your warranty. Read and follow the safety instructions that came with the product.**

 **CAUTION: Never operate your system with the cooling shroud removed. The system may get overheated quickly, resulting in shutdown and loss of data.**

- 1 Turn off the system, including any attached peripherals, and disconnect the system from the electrical outlet.
- 2 Open the system. See "Opening and Closing the System" on page 76.
- 3 Remove the RAID battery from the battery carrier. See Figure 3-9.
- 4 Hold the touch points and gently lift the cooling shroud away from the system. See Figure 3-9.



**Figure 3-9. Removing and Installing the Cooling Shroud**

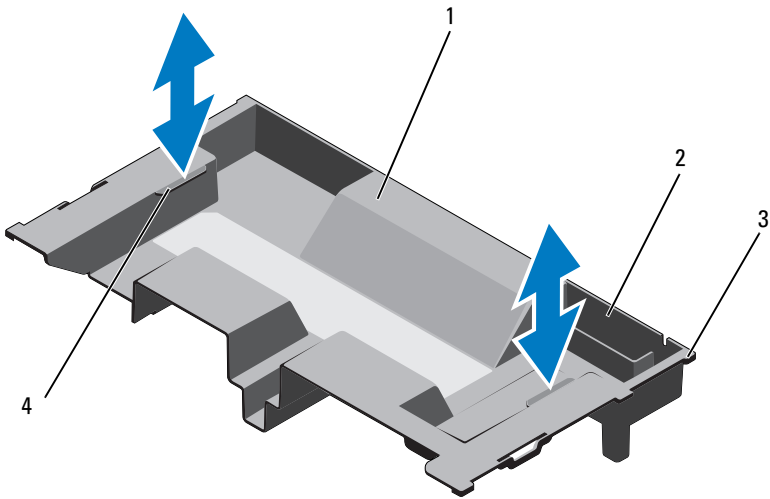

- |   |                 |   |                      |
|---|-----------------|---|----------------------|
| 1 | cooling shroud  | 2 | RAID battery carrier |
| 3 | shroud tabs (6) | 4 | touch points (2)     |

### Installing the Cooling Shroud

**NOTE:** For proper alignment of the cooling shroud in the system, ensure that the cables inside the system are routed along the chassis wall. See Figure 3-10.

- 1 Lower the cooling shroud into the system and align the cooling shroud tabs with the slots on the system. See Figure 3-9.
- 2 Insert the RAID battery into the battery carrier in the cooling shroud. See "Installing the RAID Battery" on page 119.
- 3 Close the system. See "Opening and Closing the System" on page 76.

## Front-Chassis Assembly

The front-chassis assembly consists of the hard drives, SAS/SATA backplane, optical drive, control panel assembly, and the front panel display. The front-chassis assembly is mounted on the chassis walls with a sliding rail system.

To slide the front-chassis assembly away from the chassis:

- 1 If installed, remove the front bezel. See "Removing the Front Bezel" on page 75.
- 2 Turn off the system, including any attached peripherals, and disconnect the system from the electrical outlet.
- 3 Open the system. See "Opening the System" on page 76.
- 4 Remove the cooling shroud. See "Removing the Cooling Shroud" on page 88.



**CAUTION: To prevent the memory modules from being damaged, ensure that all cables connected to the front-chassis assembly are free of obstructions.**

- 5 If required, free the power/data cables from the chassis walls.
- 6 If required, remove the SAS cables connected to the backplane. See Figure 3-10.
- 7 Press the release tabs inward and slide the assembly forward and away from the chassis. See Figure 3-10.

**Figure 3-10. Sliding the Front-Chassis Assembly**

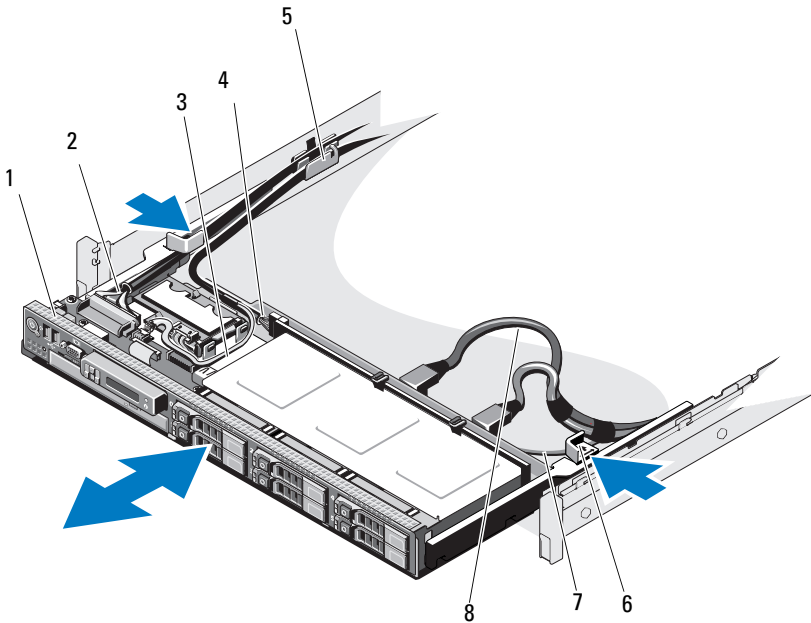

- |   |                        |   |                           |
|---|------------------------|---|---------------------------|
| 1 | front-chassis assembly | 2 | control panel cable       |
| 3 | USB cable              | 4 | SAS backplane power cable |
| 5 | cable clamp            | 6 | release tabs (2)          |
| 7 | SATA cable             | 8 | SAS cables (2)            |

To slide the front-chassis assembly back into the locked position:

- 1 Slide the assembly inside until it snaps into position.

 **NOTE:** For proper system cooling, ensure that the cables inside the system do not obstruct airflow.

- 2 Route the SAS and SATA cables along the chassis wall. See Figure 3-10.

- 3 Route the SAS backplane/USB/optical drive power cables through the cable clamp. Route the control panel cable through the cable clamp and then along the chassis wall. See Figure 3-10.

 **CAUTION: To prevent the memory modules from being damaged, ensure that all cables connected to the front-chassis assembly are free of obstructions.**

- 4 If applicable, connect the SAS cables to the SAS backplane.
- 5 Replace the cooling shroud. See "Installing the Cooling Shroud" on page 89.
- 6 Close the system. See "Closing the System" on page 77.
- 7 Reconnect the system to its electrical outlet and turn the system on, including any attached peripherals.
- 8 If applicable, replace the front bezel. See "Installing the Front Bezel" on page 75.

## System Memory

Your system supports ECC DDR3 registered DIMMs (RDIMMs) and unbuffered registered DIMMs (UDIMMs). Quad-rank DIMMs of 1066 MHz and single- and dual-rank DIMMs of 1333 MHz are also supported. RDIMMs of capacities 2 GB, 4 GB, and 8 GB are supported for a total of up to 256 GB.

The system consists of 32 memory sockets split into four sets of eight sockets; one set for each processor. Each eight-memory socket set is further organized into four DDR3 memory channels. The first socket of each DDR3 memory channel is marked with a white release lever.

Each channel supports up to two single-, dual-, or quad-rank RDIMMs or two UDIMMs. The interface uses either 2 GB, 4 GB, or 8 GB RDIMMs and 1 GB, 2 GB, or 8 GB UDIMMs.

The following features are available with respect to memory:

- Each processor has four DDR3 channels that support speeds up to 1333 MHz.
- UDIMMs and RDIMMs cannot be mixed.
- Quad-Rank DIMM types support speeds up to 1066 MHz.
- Your system may support online memory sparing.
- Mixing of memory sizes and ranks is allowed for flexibility.
- Up to 256 GB of memory (with 32 8 GB RDIMMs)

## General Memory Module Installation Guidelines

To ensure optimal performance of your system, observe the following general guidelines when configuring your system memory:



**NOTE:** Memory configurations that fail to observe these guidelines can prevent your system from starting and producing any video output.

- DIMMs must be populated in matched pairs for each processor (for example, A1/A2, A3/A4). Single DIMM operation is not supported.
- All processor memory channels must be populated identically (same speed, size, and type).
- The memory configuration for each processor must be identical for optimal performance.
- Memory modules must be installed beginning with socket A1 or A2 for processor 1, B1 or B2 for processor 2, and C1 or C2 for processor 3, D1 or D2 for processor 4.
- In case of mixed-rank population, first populate the DIMM with the highest number of ranks (in sockets with white release levers).
- If memory modules with different speeds are installed, they operate at the speed of the slowest installed memory module(s).
- If online sparing is enabled, identical DIMMs must be installed in the same slots across each channel.

The system supports advanced ECC, memory interleaving, and online sparing. For information on memory configurations, see Table 3-2 and Table 3-3.

## Memory Sparing Support

Memory sparing is supported in systems that have one of the fully populated memory configurations shown in Table 3-2 and Table 3-3. The memory sparing feature must be enabled in the **Memory Settings** screen of the System Setup program. See "Using the System Setup Program and UEFI Boot Manager" on page 53.



**NOTE:** The memory sparing and node interleaving features cannot be used at the same time. To use memory sparing, you must disable the **Node Interleaving** option in the **System Setup** program.

To support memory sparing, all eight DIMM sockets of each CPU must be populated. When enabled, memory sparing allocates and reserves one rank of memory from the installed DIMMs and is large enough to act as spare memory in the event of a memory rank failure where the contents of the failed rank is copied to the spared rank.

**Table 3-2. Memory Configurations (Two Processors)**



**NOTE:** DIMMs A1–A8 are assigned to processor 1, DIMMs B1–B8 are assigned to processor 2, and so on.

System Capacity (in GB)	Number of DIMMs	DIMM Size (in GB)	DIMM Type	Organization	Processors	
					1	2
8	8	1	RDIMM	x8	A1,A2,A3,A4	B1,B2, B3,B4
16	8	2	UDIMM	x8	A1,A2,A3,A4	B1,B2, B3,B4
16	8	2	RDIMM	x8	A1,A2,A3,A4	B1,B2, B3,B4
32	16	2	UDIMM	x8	A1,A2,A3,A4,A5,A6, A7,A8	B1,B2,B3,B4,B5,B6, B7,B8
32	16	2	RDIMM	x8	A1, A2, A3, A4, A5,A6,A7,A8	B1,B2,B3,B4,B5,B6, B7,B8
64	16	4	RDIMM	x4	A1,A2,A3,A4,A5,A6, A7,A8	B1,B2,B3,B4,B5,B6, B7,B8
96 <sup>a</sup>	16	8 and 4	RDIMM	x4	A1,A2,A3,A4,A5,A6, A7,A8	B1,B2,B3,B4,B5,B6, B7,B8
128	16	8	RDIMM	x4	A1,A2,A3,A4,A5,A6, A7,A8	B1,B2,B3,B4,B5,B6, B7,B8

a. Eight 8 GB DIMMS are populated in slots A1–A8 and eight 4 GB DIMMS are populated in slots B1–B8.

**Table 3-3. Memory Configurations (Four Processors)**

System Capacity	Number of DIMMs	DIMM Size (in GB)	DIMM Type	Organization	Processors			
					1	2	3	4
16	16	1	UDIMM	x8	A1,A2,A3, A4	B1,B2,B3, B4	C1,C2, C3,C4	D1,D2, D3,D4
16	16	1	RDIMM	x8	A1,A2,A3, A4	B1,B2,B3, B4	C1,C2, C3,C4	D1,D2, D3,D4
32	16	2	UDIMM	x8	A1,A2,A3, A4	B1,B2,B3, B4	C1,C2, C3,C4	D1,D2, D3,D4
32	16	2	RDIMM	x8	A1,A2,A3, A4	B1,B2,B3, B4	C1,C2, C3,C4	D1,D2, D3,D4
64	32	2	UDIMM	x8	A1,A2,A2 3,A4,A5,A 6,A7,A8	B1,B2,B3, B4, B5, B6, B7, B8	C1,C2, C3,C4, C5, C6, C7, C8	D1,D2, D3,D4, D5, D6, D7, D8
64	32	2	RDIMM	x8	A1,A5,A2, A6,A3,A7, A4,A8	B1,B5,B2, B6,B3,B7, B4,B8	C1,C5, C2,C6,C 3,C7,C4, C8	D1,D5, D2,D6, D3,D7, D4,D8
64	16	4	RDIMM	x4	A1,A2,A3, A4	B1,B2, B3,B4	C1,C2, C3,C4	D1,D2, D3,D4
96 <sup>a</sup>	32	4 and 2	RDIMM	x4	A1,A5, A2,A6,A3, A7,A4,A8	B1,B5,B2, B6,B3,B7, B4,B8	C1,C5, C2,C6, C3,C7, C4,C8	D1,D5, D2,D6, D3,D7, D4,D8
128	32	4	RDIMM	x4	A1,A5,A2, A6,A3,A7, A4,A8	B1,B5,B2, B6,B3,B7, B4,B8	C1,C5, C2,C6, C3,C7, C4,C8	D1,D5 ,D2,D6, D3,D7, D4,D8

**Table 3-3. Memory Configurations (Four Processors) (continued)**

System Capacity	Number of DIMMs	DIMM Size (in GB)	DIMM Type	Organization	Processors			
					1	2	3	4
160 <sup>b</sup>	32	8 and 2	RDIMM	x4	A1,A5,A2, A6,A3,A7, A4,A8	B1,B5,B2, B6,B3,B7, B4,B8	C1,C5, C2,C6, C3,C7, C4,C8	D1,D5, D2,D6, D3,D7, D4,D8
192 <sup>c</sup>	32	8 and 4	RDIMM	x4	A1,A5,A2, A6,A3,A7, A4,A8	B1,B5,B2, B6,B3,B7, B4,B8	C1,C5, C2,C6, C3,C7, C4,C8	D1,D5, D2,D6, D3,D7, D4,D8
256	32	8	RDIMM	x4	A1,A5,A2, A6,A3,A7, A4,A8	B1,B5,B2, B6,B3,B7, B4,B8	C1,C5, C2,C6, C3,C7, C4,C8	D1,D5, D2,D6, D3,D7, D4,D8

a. Eight 4 GB DIMMS are populated in slots A1–A8, eight 4 GB DIMMS are populated in slots B1–B8, eight 2 GB DIMMS are populated in slots C1–C8, and eight 2 GB DIMMS are populated in slots D1–D8.

b. Eight 8 GB DIMMS are populated in slots A1–A8, eight 8 GB DIMMS are populated in slots B1–B8, eight 2 GB DIMMS are populated in slots C1–C8, and eight 2 GB DIMMS are populated in slots D1–D8.

c. Eight 8 GB DIMMS are populated in slots A1–A8, eight 8 GB DIMMS are populated in slots B1–B8, eight 4 GB DIMMS are populated in slots C1–C8, and eight 4 GB DIMMS are populated in slots D1–D8.



## Installing Memory Modules

 **WARNING:** The memory modules are hot to touch for some time after the system has been powered down. Allow time for the memory modules to cool before handling them. Handle the memory modules by the card edges. Avoid touching the components on the memory module and the connectors.

 **CAUTION:** Many repairs may only be done by a certified service technician. You should only perform troubleshooting and simple repairs as authorized in your product documentation, or as directed by the online or telephone service and support team. Damage due to servicing that is not authorized by Dell is not covered by your warranty. Read and follow the safety instructions that came with the product.

- 1 If installed, remove the front bezel. See "Removing the Front Bezel" on page 75.
- 2 Turn off the system, including any attached peripherals, and disconnect the system from the electrical outlet.
- 3 Open the system. See "Opening the System" on page 76.
- 4 Remove the cooling shroud. See "Removing the Cooling Shroud" on page 88.
- 5 If applicable, slide the front-chassis assembly away from the chassis. See "Front-Chassis Assembly" on page 90.
- 6 Press down on the ejectors on each end of the socket until the memory-module blank pops out of the socket. See Figure 3-11.

 **NOTE:** Ensure that you retain any removed memory-module blanks for future use.

 **CAUTION:** Handle each memory module only on either card edge, making sure not to touch the memory module components or connectors.

**Figure 3-11. Installing and Removing a Memory Module**

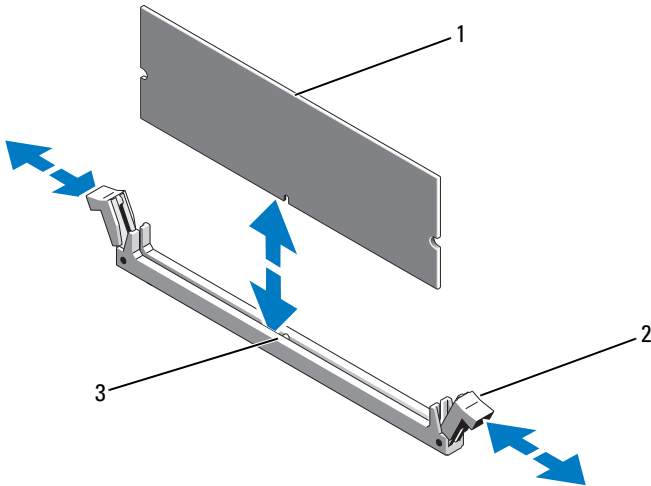

- 1 memory module
- 2 memory module socket ejectors (2)
- 3 alignment key

**7** Align the memory module's edge connector with the alignment key of the memory module socket, and insert the memory module in the socket.

**NOTE:** The memory module socket has an alignment key that allows you to install the memory module in the socket in only one way.

**8** Press down on the memory module with your thumbs to lock the memory module into the socket.

When the memory module is properly seated in the socket, the ejectors on the memory module socket align with the ejectors on the other sockets that have memory modules installed.

**9** Repeat step 6 through step 8 of this procedure to install the remaining memory modules. See Table 3-2.

**10** If applicable, slide the front-chassis assembly back into the chassis. See "Front-Chassis Assembly" on page 90.

**11** Replace the cooling shroud. See "Installing the Cooling Shroud" on page 89.

- 12 Close the system. See "Closing the System" on page 77.
- 13 Reconnect the system to its electrical outlet and turn the system on, including any attached peripherals.
- 14 If applicable, replace the front bezel. See "Installing the Front Bezel" on page 75.
- 15 Power on the system, press <F2> to enter the System Setup program, and check the **System Memory** setting on the main System Setup screen.  
The system should have already changed the value to reflect the newly installed memory.
- 16 If the value is incorrect, one or more of the memory modules may not be installed properly. Repeat step 3 through step 15 of this procedure, checking to ensure that the memory modules are firmly seated in their sockets.
- 17 Run the system memory test in the system diagnostics. See "Running the Embedded System Diagnostics" on page 172.

## Removing Memory Modules



**WARNING:** The memory modules are hot to touch for some time after the system has been powered down. Allow time for the memory modules to cool before handling them. Handle the memory modules by the card edges and avoid touching the components on the memory module.



**CAUTION:** Many repairs may only be done by a certified service technician. You should only perform troubleshooting and simple repairs as authorized in your product documentation, or as directed by the online or telephone service and support team. Damage due to servicing that is not authorized by Dell is not covered by your warranty. Read and follow the safety instructions that came with the product.



**CAUTION:** To ensure proper system cooling, memory-module blanks must be installed in any memory socket that is not occupied. Remove memory-module blanks only if you intend to install memory modules in those sockets.

- 1 Turn off the system, including any attached peripherals, and disconnect the system from the electrical outlet.
- 2 If installed, remove the front bezel. See "Removing the Front Bezel" on page 75.
- 3 Open the system. See "Opening the System" on page 76.

 **CAUTION: Handle each memory module only on either card edge, making sure not to touch the memory module components or connectors.**

- 4 Remove the cooling shroud. See "Removing the Cooling Shroud" on page 88.
- 5 If applicable, slide the front-chassis assembly away from the chassis. See "Front-Chassis Assembly" on page 90.
- 6 Press down and out on the ejectors on each end of the socket until the memory module pops out of the socket. See Figure 3-11.
- 7 Lift out the memory module.
  -  **NOTE:** If you are not replacing the memory module, insert a memory module blank in the socket.
- 8 If applicable, slide the front-chassis assembly back into the chassis. See "Front-Chassis Assembly" on page 90.
- 9 Close the system. See "Closing the System" on page 77.
- 10 If applicable, replace the front bezel. See "Installing the Front Bezel" on page 75.
- 11 Reconnect the system to its electrical outlet and turn the system on, including any attached peripherals.

## Cooling Fans

Your system contains six hot-swappable fans mounted in a fan assembly and provides cooling for the processors, expansion cards, and memory modules.

 **NOTE:** In the event of a problem with a particular fan, the fan number is referenced by the system's management software, allowing you to easily identify and replace the proper fan by noting the fan numbers on the cooling fan assembly.

### Removing a Cooling Fan

 **WARNING: Opening or removing the system cover when the system is on may expose you to a risk of electric shock. Exercise utmost care while removing or installing cooling fans.**

 **WARNING: Allow time for the fan to stop spinning after removing it from the system.**

 **WARNING: Do not attempt to operate the system without the cooling fans.**

**CAUTION:** Many repairs may only be done by a certified service technician. You should only perform troubleshooting and simple repairs as authorized in your product documentation, or as directed by the online or telephone service and support team. Damage due to servicing that is not authorized by Dell is not covered by your warranty. Read and follow the safety instructions that came with the product.

**NOTE:** The procedure for removing each individual fan module is the same.

- 1 Open the system. See "Opening the System" on page 76.
- 2 Press the release tab and lift the fan out of the cooling fan assembly. See Figure 3-12.

**Figure 3-12. Removing and Installing a Cooling Fan**

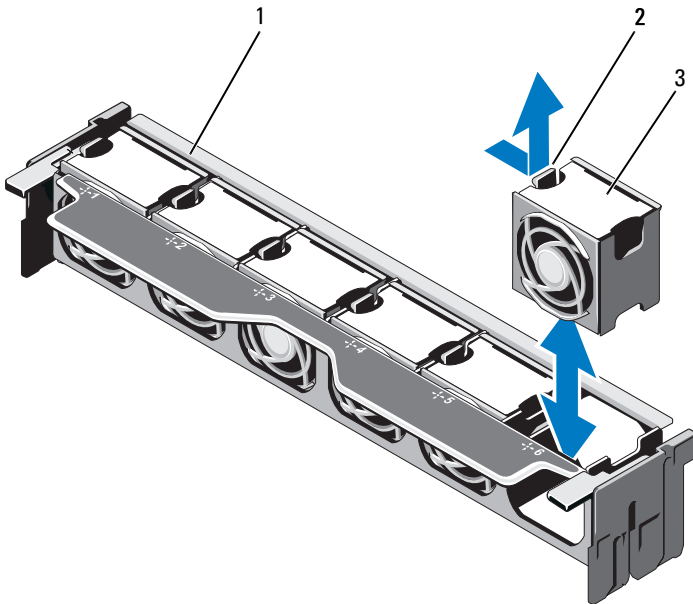



- 1 fan assembly
- 2 release tab
- 3 fan module

2 release tab

- 3 fan module

## Installing a Cooling Fan

 **WARNING:** Opening or removing the system cover when the system is on may expose you to a risk of electric shock. Exercise utmost care while removing or installing cooling fans.

 **CAUTION:** Many repairs may only be done by a certified service technician. You should only perform troubleshooting and simple repairs as authorized in your product documentation, or as directed by the online or telephone service and support team. Damage due to servicing that is not authorized by Dell is not covered by your warranty. Read and follow the safety instructions that came with the product.

- 1 Align the connector on the fan with the connector on the system board. See Figure 6-1.
- 2 Lower the fan into the cooling fan assembly until the release tab snaps into place. See Figure 3-12.
- 3 Close the system. See "Closing the System" on page 77.

## Removing the Cooling Fan Assembly

 **CAUTION:** Many repairs may only be done by a certified service technician. You should only perform troubleshooting and simple repairs as authorized in your product documentation, or as directed by the online or telephone service and support team. Damage due to servicing that is not authorized by Dell is not covered by your warranty. Read and follow the safety instructions that came with the product.

- 1 Turn off the system, including any attached peripherals, and disconnect the system from its electrical outlet.
- 2 Open the system. See "Opening the System" on page 76.
- 3 Lift the blue release levers to release the cooling fan assembly from the chassis. See Figure 3-13.
- 4 Grasp the blue release levers and lift the cooling fan assembly out of the system. See Figure 3-13.

**Figure 3-13. Removing and Installing the Cooling Fan Assembly**

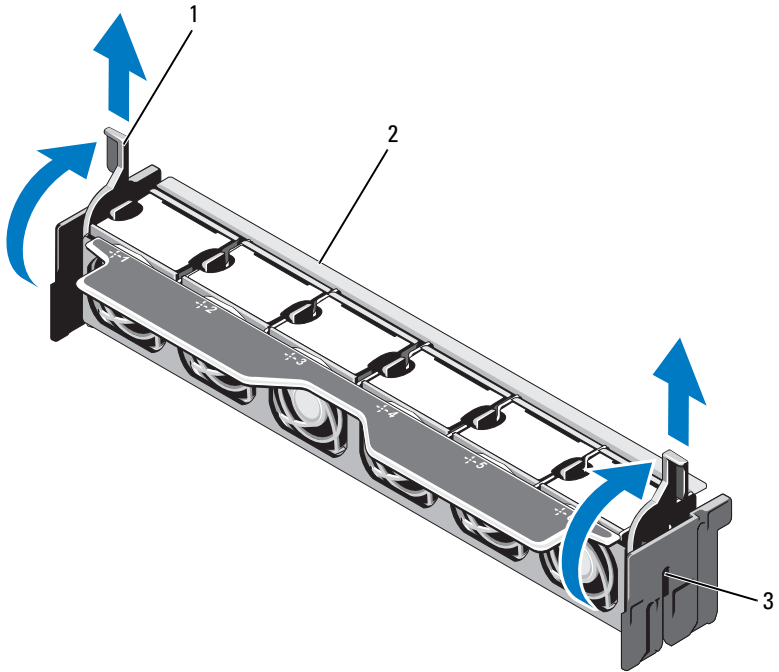

- 1 release levers (2)
- 3 slots (2)

- 2 fan assembly

## Installing the Cooling Fan Assembly



**CAUTION: Many repairs may only be done by a certified service technician. You should only perform troubleshooting and simple repairs as authorized in your product documentation, or as directed by the online or telephone service and support team. Damage due to servicing that is not authorized by Dell is not covered by your warranty. Read and follow the safety instructions that came with the product.**

- 1 Orient the cooling fan assembly as shown in Figure 3-1.
- 2 Align the slots on the sides of the cooling fan assembly with the tabs on the chassis. See Figure 3-13.
- 3 Insert the cooling fan assembly into the system and lower the blue release levers to lock it in place.
- 4 Close the system. See "Closing the System" on page 77.
- 5 Reconnect the system to its electrical outlet and turn the system on, including any attached peripherals.

## Internal USB Memory Key

An optional USB memory key installed inside your system can be used as a boot device, security key, or mass storage device. The USB connector must be enabled by the **Internal USB Port** option in the **Integrated Devices** screen of the System Setup program.

To boot from the USB memory key, configure the USB memory key with a boot image and then specify the USB memory key in the boot sequence in the System Setup program.



**CAUTION: Many repairs may only be done by a certified service technician. You should only perform troubleshooting and simple repairs as authorized in your product documentation, or as directed by the online or telephone service and support team. Damage due to servicing that is not authorized by Dell is not covered by your warranty. Read and follow the safety instructions that came with the product.**

- 1 Turn off the system, including any attached peripherals, and disconnect the system from the electrical outlet.
- 2 Open the system. See "Opening the System" on page 76.
- 3 Locate the USB connector on the control panel board. See Figure 3-29.



- 4 Insert the USB memory key into the USB connector. See Figure 3-14.
- 5 Close the system. See "Closing the System" on page 77.
- 6 Reconnect the system to its electrical outlet and turn the system on, including any attached peripherals.
- 7 Enter the System Setup program and verify that the USB key has been detected by the system. See "Using the System Setup Program and UEFI Boot Manager" on page 53.

**Figure 3-14. Removing and Installing a USB Memory Key**

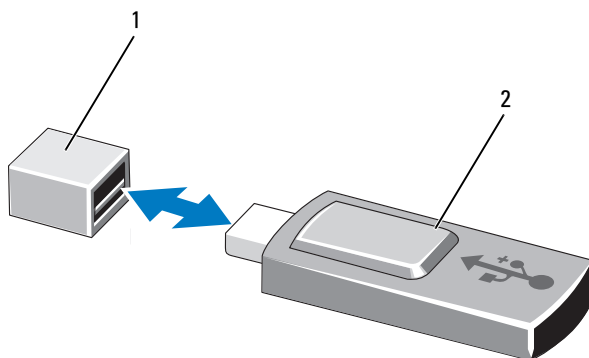

1 USB memory key connector

2 USB memory key

## Internal NIC Hardware Key

Any additional future functionalities for the system's integrated NICs are enabled by installing an optional NIC hardware key in the iSCSI KEY socket on the system board. See Figure 6-1.

**⚠ CAUTION: Many repairs may only be done by a certified service technician. You should only perform troubleshooting and simple repairs as authorized in your product documentation, or as directed by the online or telephone service and support team. Damage due to servicing that is not authorized by Dell is not covered by your warranty. Read and follow the safety instructions that came with the product.**



# Expansion Cards and Expansion-Card Risers

## Expansion Card Installation Guidelines

Your system supports up to six Generation 2 PCIe expansion cards using connectors on the system board and two expansion-card risers. To locate the expansion-card connectors on the system board, see Figure 6-1 and to locate the expansion-card connectors on the expansion-card risers, see Figure 6-4 and Figure 6-5.

The following are the slot configurations on the risers and the system board:

- **Riser 1**
  - Slot 1: x8 link expansion slot (24.13 cm [9.5"] length)
  - Slot 2: x4 link expansion slot (low-profile 24.13 cm [9.5"] maximum length, with a standard height bracket)
- **System Board**
  - Slot 3: x8 link expansion slot (low-profile 24.13 cm [9.5"] length)
  - Slot 4: x8 link expansion slot (low-profile 24.13 cm [9.5"] length)
- **Riser 2**
  - Slot 5: x8 link expansion slot (24.13 cm [9.5"] length)
  - Slot 6: x8 link expansion slot (24.13 cm [9.5"] length)



**NOTE:** The length specified above is of the expansion cards.



**NOTE:** Ensure that both riser 1 and riser 2 are installed in the system before you turn the system on.



**CAUTION:** To ensure proper cooling, only two out of the six expansion cards can have a power consumption greater than 15 W (up to 25 W maximum), not including the integrated storage controller.

Table 3-4 provides a guide for installing expansion cards to ensure proper cooling and mechanical fit. The expansion cards with the highest priority should be installed first using the slot priority indicated. All other expansion cards should be installed in card priority and slot priority order.

**Table 3-4. Expansion Card Installation Priority**

<b>Card Priority</b>	<b>Card Type</b>	<b>Slot Priority</b>	<b>Max Allowed</b>
1	PERC H800	6,5	2
2	PERC 6/E	6,5	2
3	SAS 5/E	6,5	2
4	10 Gb NICs	6,5,1,2	2
5	Converged Network Adapters (CNA)	6,5,1,2	2
6	8G Fiber Channel (single port)	6,5,1,2	4
7	6 Gbps SAS HBA	6,5,1,2	2
8	8G Fiber Channel (dual port)	6,5,1,2	2
9	4G Fibre Channel (single port)	2,1,6,5	2-4
10	4G Fibre Channel (dual port)	2,1,6,5	2-4
11	SCSI HBA	2,1,6,5	2
12	1 Gb NICs	2,1,6,5,3,4	2-4

### Installing an Expansion Card

 **CAUTION: Many repairs may only be done by a certified service technician. You should only perform troubleshooting and simple repairs as authorized in your product documentation, or as directed by the online or telephone service and support team. Damage due to servicing that is not authorized by Dell is not covered by your warranty. Read and follow the safety instructions that came with the product.**

- 1 Unpack the expansion card and prepare it for installation.  
For instructions, see the documentation accompanying the card.
- 2 Turn off the system, including any attached peripherals, and disconnect the system from the electrical outlet.
- 3 Open the system. See "Opening the System" on page 76.
- 4 Locate the expansion-card connector on the system board/riser. See Figure 6-1 and Figure 3-16.

- 5 Lift the expansion-card latch and remove the filler bracket. See Figure 3-16.
-  **NOTE:** To install an expansion card in the expansion-card connector on the system board, go to step 7.
- 6 Holding the card by its edges, position the card so that the card-edge connector aligns with the expansion-card connector.
  - 7 Insert the card-edge connector firmly into the expansion-card connector until the card is fully seated.
  - 8 Replace the expansion-card latch. See Figure 3-16.

**Figure 3-16. Installing and Removing an Expansion Card**

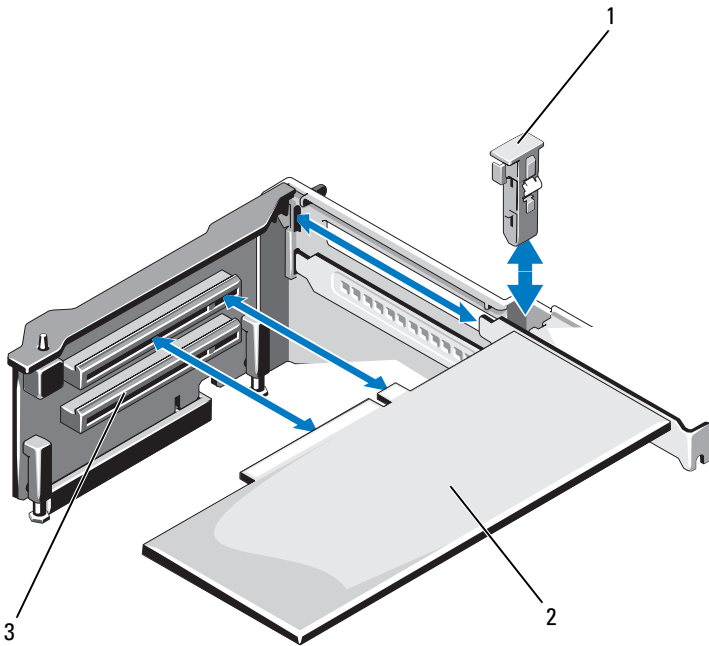

- |   |                          |   |                |
|---|--------------------------|---|----------------|
| 1 | expansion-card latch     | 2 | expansion card |
| 3 | expansion-card connector |   |                |

- 9 If applicable, connect the cables to the expansion card.
- 10 Replace the expansion-card latch.
- 11 Close the system. See "Closing the System" on page 77.
- 12 Reconnect the system to its electrical outlet and turn the system on, including any attached peripherals.
- 13 Install any device drivers required for the card as described in the documentation for the card.

## Removing an Expansion Card



**CAUTION:** Many repairs may only be done by a certified service technician. You should only perform troubleshooting and simple repairs as authorized in your product documentation, or as directed by the online or telephone service and support team. Damage due to servicing that is not authorized by Dell is not covered by your warranty. Read and follow the safety instructions that came with the product.

- 1 Turn off the system, including any attached peripherals, and disconnect the system from the electrical outlet.
- 2 Open the system. See "Opening the System" on page 76.
- 3 If applicable, disconnect all cables from the card.
- 4 Lift the expansion-card latch. See Figure 3-16.
- 5 Grasp the expansion card by its edges, and carefully remove it from the expansion-card connector.
- 6 If you are removing the card permanently, install a metal filler bracket over the empty expansion card slot on the chassis.
- 7 Replace the expansion-card latch.



**NOTE:** You must install a filler bracket over an empty expansion slot to maintain Federal Communications Commission (FCC) certification of the system. The brackets also keep dust and dirt out of the system and aid in proper cooling and airflow inside the system.

- 8 Close the system. See "Closing the System" on page 77.
- 9 Reconnect the system to its electrical outlet and turn the system on, including any attached peripherals.

## Removing Expansion-Card Riser 1



**CAUTION:** Many repairs may only be done by a certified service technician. You should only perform troubleshooting and simple repairs as authorized in your product documentation, or as directed by the online or telephone service and support team. Damage due to servicing that is not authorized by Dell is not covered by your warranty. Read and follow the safety instructions that came with the product.

- 1 Turn off the system, including any attached peripherals, and disconnect the system from the electrical outlet.
- 2 Open the system. See "Opening the System" on page 76.
- 3 If installed, remove the expansion card(s) from the expansion-card slot(s). See "Removing an Expansion Card" on page 110.
- 4 If installed, remove the storage controller card. See "Removing the Integrated Storage Controller Card" on page 115.
- 5 To remove the expansion-card riser, press the blue tab on the riser and lift the expansion-card riser from the connector on the system board. See Figure 3-17.

**Figure 3-17. Installing and Removing Expansion-Card Riser 1**

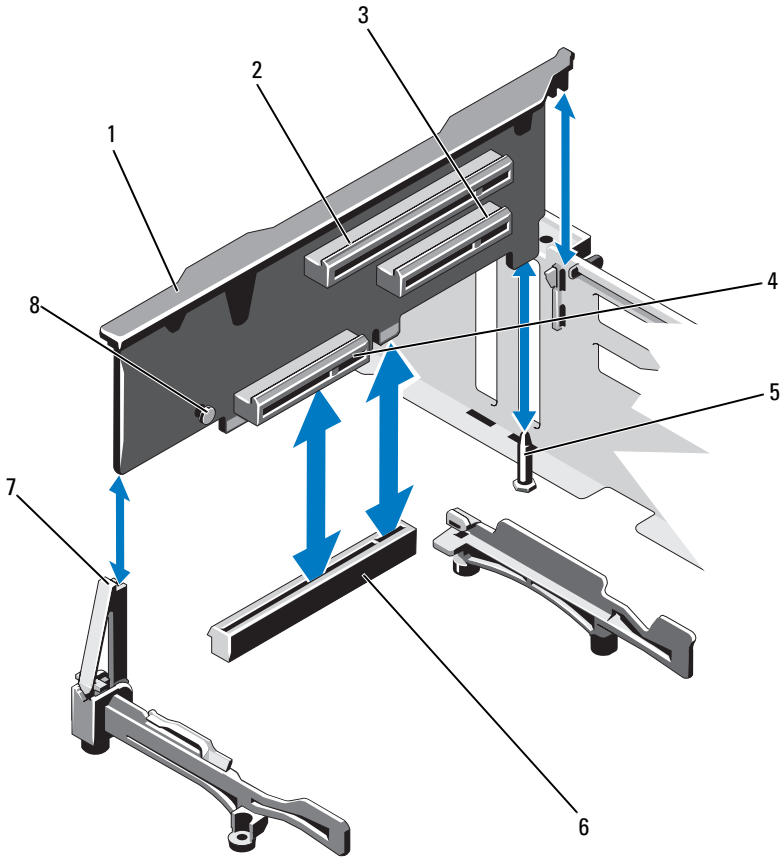

- |                          |   |
|--------------------------|---|
| 1 expansion-card riser 1 | 2 expansion-card slot 1                   |
| 3 expansion-card slot 2  | 4 integrated storage controller card slot |
| 5 riser guide pin        | 6 connector on system board               |
| 7 riser guide            | 8 blue tab                                |



## Installing Expansion-Card Riser 1



**CAUTION: Many repairs may only be done by a certified service technician. You should only perform troubleshooting and simple repairs as authorized in your product documentation, or as directed by the online or telephone service and support team. Damage due to servicing that is not authorized by Dell is not covered by your warranty. Read and follow the safety instructions that came with the product.**

- 1 Align the expansion-card riser with the slot on the riser guide and the riser guide pin on the system board. See Figure 3-17.



**NOTE:** If the riser guide is in a horizontal position, rotate it to upright position. See Figure 3-17.

- 2 Lower the expansion-card riser into place until the expansion-card riser connector is fully seated.
- 3 If applicable, replace the storage controller card. See "Installing the Integrated Storage Controller Card" on page 117.
- 4 If applicable, replace the expansion card(s). See "Installing an Expansion Card" on page 108 on page 72.
- 5 Close the system. See "Closing the System" on page 77.
- 6 Reconnect the system to its electrical outlet and turn the system on, including any attached peripherals.

## Removing Expansion-Card Riser 2



**CAUTION: Many repairs may only be done by a certified service technician. You should only perform troubleshooting and simple repairs as authorized in your product documentation, or as directed by the online or telephone service and support team. Damage due to servicing that is not authorized by Dell is not covered by your warranty. Read and follow the safety instructions that came with the product.**

- 1 Turn off the system, including any attached peripherals, and disconnect the system from the electrical outlet.
- 2 Open the system. See "Opening the System" on page 76.
- 3 If installed, remove the expansion card from the expansion-card slot. See "Removing an Expansion Card" on page 110.
- 4 To remove the expansion-card riser, lift the expansion-card riser from the connector on the system board. See Figure 3-18.

**Figure 3-18. Installing and Removing Expansion-Card Riser 2**

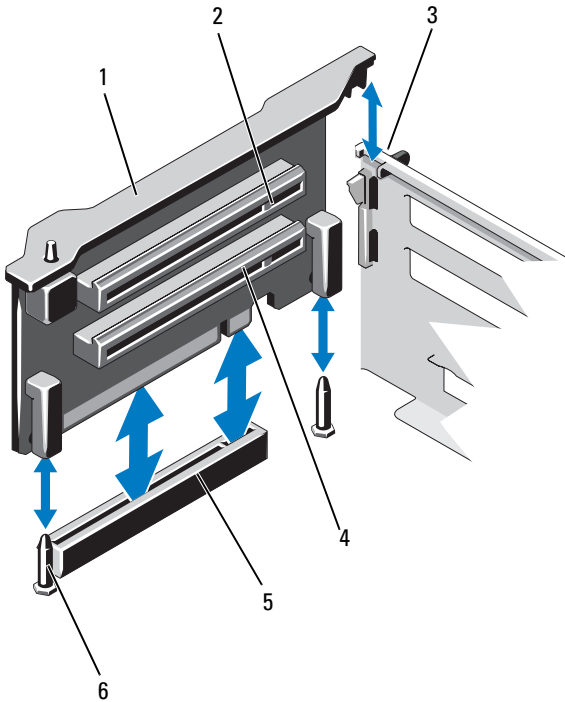

- |   |                                   |   |                       |
|---|-----------------------------------|---|-----------------------|
| 1 | expansion-card riser 2            | 2 | expansion-card slot 5 |
| 3 | slot on chassis                   | 4 | expansion-card slot 6 |
| 5 | riser 2 connector on system board | 6 | riser guide pins (2)  |

### **Installing Expansion-Card Riser 2**

- 1 Align the expansion-card riser with the riser guide pins on the system board and the slot on the chassis. See Figure 3-17.
- 2 Lower the expansion-card riser into place until the expansion-card riser connector is fully seated.
- 3 If applicable, replace the expansion card(s). See "Installing an Expansion Card" on page 108 on page 72.

- 4 Close the system. See "Closing the System" on page 77.
- 5 Reconnect the system to its electrical outlet and turn the system on, including any attached peripherals.

## Integrated Storage Controller Card

Your system includes a dedicated expansion-card slot on expansion-card riser 1 for an integrated controller card that provides the integrated storage subsystem for your system's internal hard drives. The controller supports SAS and SATA hard drives and also enables you to set up the hard drives in RAID configurations as supported by the version of the storage controller included with your system.

### Removing the Integrated Storage Controller Card



**CAUTION: Many repairs may only be done by a certified service technician. You should only perform troubleshooting and simple repairs as authorized in your product documentation, or as directed by the online or telephone service and support team. Damage due to servicing that is not authorized by Dell is not covered by your warranty. Read and follow the safety instructions that came with the product.**

- 1 Turn off the system, including any attached peripherals, and disconnect the system from the electrical outlet.
- 2 Open the system. See "Opening the System" on page 76.
- 3 Remove the cooling shroud. See "Removing the Cooling Shroud" on page 88.
- 4 Remove the cooling fan assembly. See "Removing the Cooling Fan Assembly" on page 102.
- 5 Disconnect the cables connected to the card. See Figure 3-19.
- 6 Bend both the alignment guides outward and pull the storage controller card out of the connector. See Figure 3-19.
- 7 Close the system. See "Closing the System" on page 77.

**Figure 3-19. Removing and Installing the Integrated Storage Controller Card**

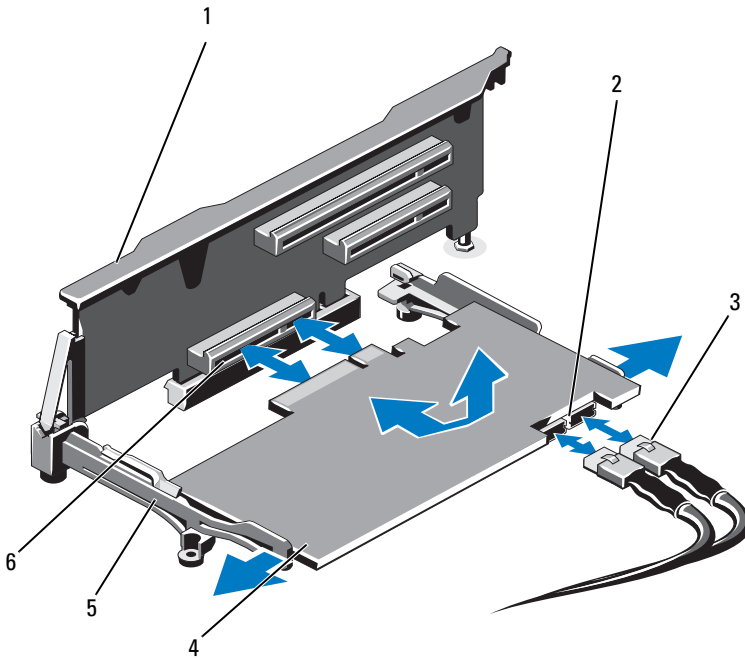

- |   |                      |   |  |
|---|----------------------|---|--|
| 1 | expansion card riser | 2 | SAS data cable connectors (2)                |
| 3 | SAS data cables (2)  | 4 | integrated storage controller card           |
| 5 | alignment guides (2) | 6 | integrated storage controller card connector |

## Installing the Integrated Storage Controller Card



**CAUTION:** Many repairs may only be done by a certified service technician. You should only perform troubleshooting and simple repairs as authorized in your product documentation, or as directed by the online or telephone service and support team. Damage due to servicing that is not authorized by Dell is not covered by your warranty. Read and follow the safety instructions that came with the product.

- 1 Turn off the system, including any attached peripherals, and disconnect the system from the electrical outlet.
- 2 Open the system. See "Opening the System" on page 76.
- 3 Remove the cooling shroud. See "Removing the Cooling Shroud" on page 88.
- 4 Remove the cooling fan assembly. See "Removing the Cooling Fan Assembly" on page 102.
- 5 Hold the card by its edges and angle it between the alignment guides on riser 1 until it is fully seated. See Figure 3-1.
- 6 Connect the SAS data cables to the integrated storage controller card. See Figure 3-19.



**NOTE:** Ensure that you connect the cable according to the connector labels on the cable. The cable does not function properly if reversed.

- 7 If applicable, connect the RAID battery cable. See Figure 3-20.
- 8 Route the SAS data cable through the channel on the inner side of the chassis.
- 9 Attach the cable labeled "SAS A" to SAS A connector on the backplane, and attach the cable labeled "SAS B" to SAS B connector on the backplane. See Figure 3-19.
- 10 Replace the cooling fan assembly. See "Installing the Cooling Fan Assembly" on page 104.
- 11 Replace the cooling shroud. See "Installing the Cooling Shroud" on page 89.
- 12 Close the system. See "Closing the System" on page 77.
- 13 Reconnect the system to its electrical outlet and turn the system on, including any attached peripherals.

## RAID Battery (Optional)

The information in this section applies only to systems with the optional PERC cards without an integral battery backup unit.

### Removing a RAID Battery

- 1 Turn off the system, including any attached peripherals, and disconnect the system from the electrical outlet.
- 2 Open the system. See "Opening the System" on page 76.
- 3 Remove the cooling fan assembly. See "Removing the Cooling Fan Assembly" on page 102.
- 4 Press the tab on the RAID battery cable connector and pull the cable out of the connector on the storage controller card.
- 5 Free the RAID battery cable from the slot in the battery carrier. See Figure 3-20.
- 6 Lift the RAID battery out of the battery carrier.

**Figure 3-20. Removing and Installing the RAID Battery**

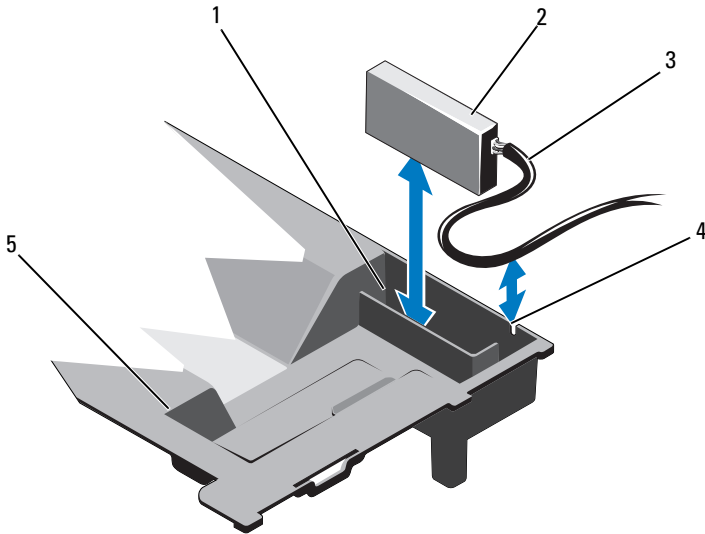

- |   |                      |   |                           |
|---|----------------------|---|---------------------------|
| 1 | RAID battery carrier | 2 | RAID battery              |
| 3 | RAID battery cable   | 4 | RAID battery carrier slot |
| 5 | cooling shroud       |   |                           |

### **Installing the RAID Battery**

- 1** Insert the RAID battery into the battery carrier in the cooling shroud. See Figure 3-20.
- 2** Route the RAID battery cable along the chassis wall and through the slot in the battery carrier.
- 3** Tuck any cable slack into the area in front of the battery carrier slot.
- 4** Connect the battery cable to the connector on the integrated storage controller card.
- 5** Replace the cooling fan assembly. See "Installing the Cooling Fan Assembly" on page 104.
- 6** Close the system. See "Closing the System" on page 77.
- 7** Reconnect the system to its electrical outlet and turn the system on, including any attached peripherals.

# iDRAC6 Enterprise Card (Optional)

## Removing an iDRAC6 Enterprise Card



**CAUTION:** Many repairs may only be done by a certified service technician. You should only perform troubleshooting and simple repairs as authorized in your product documentation, or as directed by the online or telephone service and support team. Damage due to servicing that is not authorized by Dell is not covered by your warranty. Read and follow the safety instructions that came with the product.

- 1 Turn off the system, including any attached peripherals, and disconnect the system from the electrical outlet.
- 2 If applicable, disconnect the Ethernet cable from the iDRAC6 Enterprise Card connector on the system back panel. See Figure 1-3.
- 3 Open the system. See "Opening the System" on page 76.
- 4 Remove the VFlash media card (if installed) from the iDRAC6 Enterprise Card. See "Removing a VFlash Media Card" on page 122.
- 5 Pull back slightly on the two tabs at the front edge of the card and gently lift the front edge of the card off the retention standoffs. See Figure 3-21.  
As the card releases from the standoffs, the connector under the card disengages from the system board connector.
- 6 Slide the card away from the back of the system until the RJ-45 connector is clear of the back panel and then lift the card out of the system.
- 7 Close the system. See "Closing the System" on page 77.
- 8 Reconnect the system and peripherals to its electrical outlet, and turn them on.



**Figure 3-21. Installing and Removing an iDRAC6 Enterprise Card (Optional)**

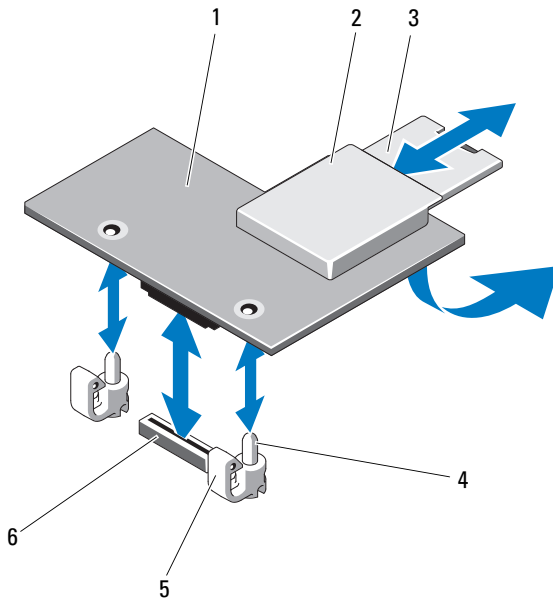

- |   |                             |   |                                  |
|---|-----------------------------|---|----------------------------------|
| 1 | iDRAC6 enterprise card      | 2 | VFlash media slot                |
| 3 | VFlash SD card              | 4 | retention standoff posts (2)     |
| 5 | retention standoff tabs (2) | 6 | iDRAC6 enterprise card connector |

### Installing an iDRAC6 Enterprise Card



**CAUTION:** Many repairs may only be done by a certified service technician. You should only perform troubleshooting and simple repairs as authorized in your product documentation, or as directed by the online or telephone service and support team. Damage due to servicing that is not authorized by Dell is not covered by your warranty. Read and follow the safety instructions that came with the product.

- 1 Turn off the system, including any attached peripherals, and disconnect the system from the electrical outlet.
- 2 Open the system. See "Opening the System" on page 76.

- 3 Remove the plastic filler plug for the iDRAC6 Enterprise port from the system back panel. See Figure 1-3.
- 4 Align the front edge of the card with the two plastic retention standoffs next to the iDRAC6 connector on the system board, and lower the card into place. See Figure 3-21 and Figure 6-1.  
When the front of the card is fully seated, the plastic standoffs snap over the edge of the card.
- 5 If applicable, connect the Ethernet cable from the iDRAC6 Enterprise Card connector on the system back panel. See Figure 1-3.
- 6 Close the system. See "Closing the System" on page 77.
- 7 Reconnect the system to its electrical outlet and turn the system on, including any attached peripherals.
- 8 Enter the iDRAC6 configuration utility and set up the Ethernet mode. See "iDRAC6 Configuration Utility" on page 71.

## VFlash Media (Optional)

The VFlash media card is a Secure Digital (SD) card that plugs into the optional iDRAC6 Enterprise card at the back corner of the system.

### Removing a VFlash Media Card

To remove the VFlash media, push inward on the card to release it, and pull the card from the card slot.

### Installing a VFlash Media Card

- 1 Locate the VFlash media slot at the back corner of the system. See Figure 1-3.
- 2 With the label side facing up, insert the contact-pin end of the SD card into the card slot on the module.  
 **NOTE:** The slot is keyed to ensure correct insertion of the card.
- 3 Press inward on the card to lock it into the slot.

# Internal Dual SD Module (Optional)

## Removing the Internal Dual SD Module

When the Redundancy option is set to **Mirror Mode** in the **Integrated Devices** screen of the system setup program, the information is replicated from one SD card to another. See "Integrated Devices Screen" on page 60.



**CAUTION: Many repairs may only be done by a certified service technician. You should only perform troubleshooting and simple repairs as authorized in your product documentation, or as directed by the online or telephone service and support team. Damage due to servicing that is not authorized by Dell is not covered by your warranty. Read and follow the safety instructions that came with the product.**

- 1 Turn off the system, including any attached peripherals, and disconnect the system from the electrical outlet.
- 2 Open the system. See "Opening the System" on page 76.
- 3 If installed, remove the SD cards from the internal dual SD module. See Figure 3-1.
- 4 Disconnect the cable from the internal dual SD module. See Figure 3-22.
- 5 Lift the latch securing the internal dual SD module to the front-chassis assembly and lift the module out of the assembly. See Figure 3-22.
- 6 Close the system. See "Closing the System" on page 77.
- 7 Reconnect the system to its electrical outlet and turn the system on, including any attached peripherals.

**Figure 3-22. Removing and Installing the Internal Dual SD Module**

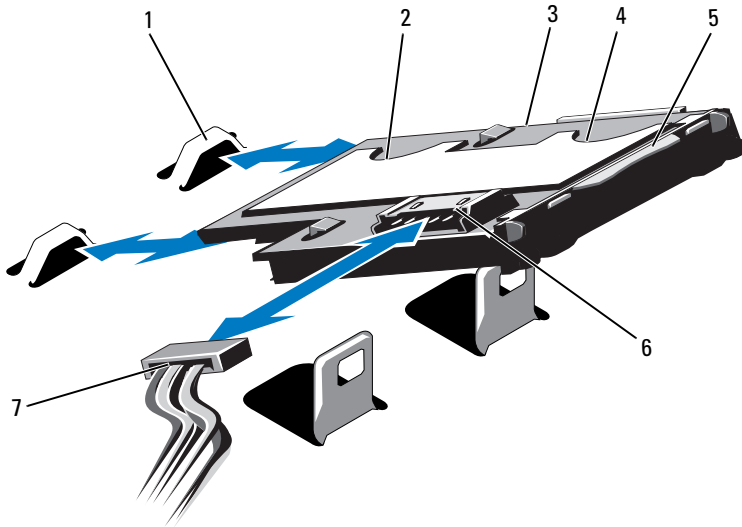

- |   |                         |   |                 |
|---|-------------------------|---|-----------------|
| 1 | hooks (2)               | 2 | SD card slot 2  |
| 3 | internal dual SD module | 4 | SD card slot 1  |
| 5 | latch                   | 6 | cable connector |
| 7 | power cable             |   |                 |

### Installing the Internal Dual SD Module

**CAUTION:** Many repairs may only be done by a certified service technician. You should only perform troubleshooting and simple repairs as authorized in your product documentation, or as directed by the online or telephone service and support team. Damage due to servicing that is not authorized by Dell is not covered by your warranty. Read and follow the safety instructions that came with the product.

- 1 Turn off the system, including any attached peripherals, and disconnect the system from the electrical outlet.
- 2 Open the system. See "Opening the System" on page 76.

- 3 Position the module so the tabs on the underside of the tray fit into the hooks on the front-chassis assembly, then lower the opposite edge of the card into place. See Figure 3-1 and Figure 3-22.
- 4 Connect the internal dual SD module cable to the connector on the control panel board.
- 5 Close the system. See "Closing the System" on page 77.
- 6 Reconnect the system to its electrical outlet and turn the system on, including any attached peripherals.

## Processors

### Removing a Processor



**CAUTION: Many repairs may only be done by a certified service technician. You should only perform troubleshooting and simple repairs as authorized in your product documentation, or as directed by the online or telephone service and support team. Damage due to servicing that is not authorized by Dell is not covered by your warranty. Read and follow the safety instructions that came with the product.**

- 1 Prior to upgrading your system, download the latest system BIOS version from [support.dell.com](http://support.dell.com) and follow the instructions included in the compressed download file to install the update on your system.
- 2 Turn off the system, including any attached peripherals, and disconnect the system from the electrical outlet. When disconnected from AC power, press and hold the power button for three seconds to fully drain the system of stored power prior to removing the cover.
- 3 Open the system. See "Opening the System" on page 76.
- 4 Remove the cooling shroud. See "Removing the Cooling Shroud" on page 88.
- 5 If applicable, slide the front chassis assembly.
- 6 If applicable, remove the cooling fan assembly. See "Removing the Cooling Fan Assembly" on page 102.



**WARNING: The heat sink and processor are hot to touch for some time after the system has been powered down. Allow the heat sink and processor to cool before handling them.**

**⚠ CAUTION: Never remove the heat sink from a processor unless you intend to remove the processor. The heat sink is necessary to maintain proper thermal conditions.**

- 7** Using a #2 Phillips screwdriver, loosen the heat-sink retention screws. See Figure 3-23.
- 8** Gently lift the heat sink off the processor and keep it aside with the thermal grease side facing up.

**Figure 3-23. Removing and Installing the Heat Sink**

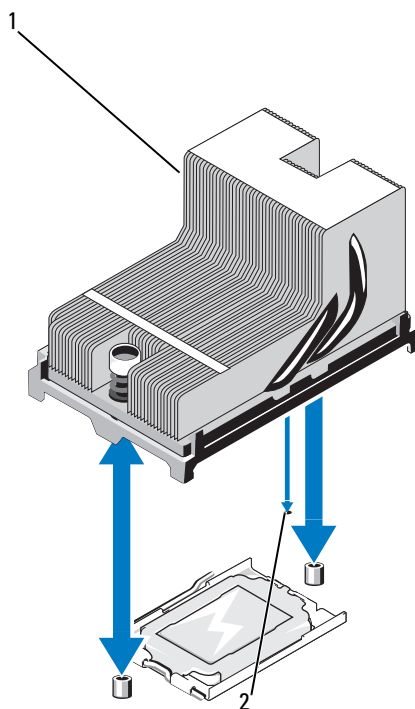

1 heat sink

2 slot on system board

**△ CAUTION: The processor is held in its socket under strong pressure. Be aware that the release lever can spring up suddenly if not firmly grasped.**

**9** Position your thumb firmly over the processor socket-release lever and release the lever from the locked position by pushing down and pulling out from under the tab. Rotate the lever 90 degrees upward until the processor is released from the socket. See Figure 3-24.

**10** Rotate the processor shield upward and out of the way. See Figure 3-24.

**Figure 3-24. Removing and Installing a Processor**

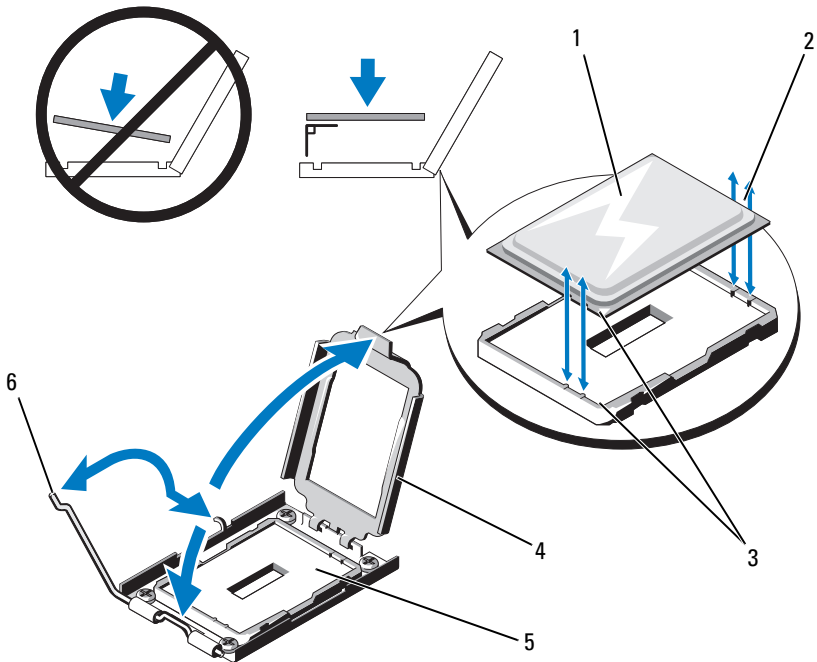

- |   |                      |   |                      |
|---|----------------------|---|----------------------|
| 1 | processor            | 2 | notches in processor |
| 3 | pin 1 indicators (2) | 4 | processor shield     |
| 5 | ZIF socket           | 6 | socket release lever |

**Figure 3-25. Removing and Installing a Processor Blank**

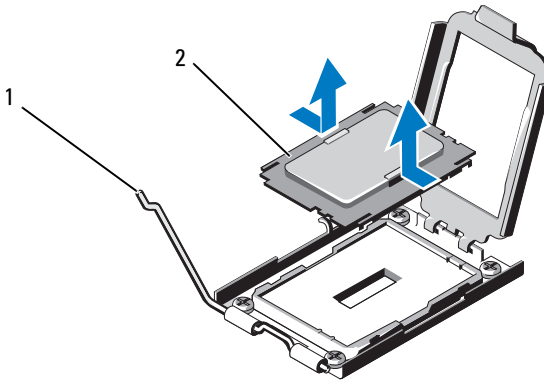

1 release lever

2 processor blank

**CAUTION:** Be careful not to bend any of the pins on the ZIF socket when removing the processor. Bending the pins can permanently damage the system board.

- 11 Carefully, lift the processor out of the socket and leave the release lever up so that the socket is ready for the new processor.

After removing the processor, place it in an antistatic container for reuse, return, or temporary storage. Do not touch the bottom of the processor. Touch only the side edges of the processor.

If you are permanently removing the processor, you must install a processor blank in the processor socket to protect the pins of the processor socket. See Figure 3-25. Installing a processor blank is similar to installing a processor. See "Installing a Processor" on page 129.



## Installing a Processor

**△ CAUTION: Many repairs may only be done by a certified service technician. You should only perform troubleshooting and simple repairs as authorized in your product documentation, or as directed by the online or telephone service and support team. Damage due to servicing that is not authorized by Dell is not covered by your warranty. Read and follow the safety instructions that came with the product.**

- 1 If you are adding a third and fourth processor for the first time, remove the processor blank from the vacant processor sockets. Removing the blank is similar to removing a processor. See "Removing a Processor" on page 125.
- 2 Remove the processor from the packing material by the processor's edges only. Do not touch the bottom of the processor. Handle the processor carefully with your fingers on the side edges. Place your free hand beneath the processor when you are moving it to the system to prevent dropping it on the floor.
- 3 Locate the pin 1 indicator on the system board socket.
- 4 Locate the pin 1 indicator on the top of the processor. The pin 1 indicator is shown as a triangle on the top of the processor. See Figure 3-24.

**△ CAUTION: Positioning the processor incorrectly can permanently damage the system board or the processor. Be careful not to bend the pins in the socket.**

- 5 Place the processor over the socket with each pin 1 aligned with the pin guide on the processor socket. See Figure 3-24.

**△ CAUTION: Do not use force to seat the processor. When the processor is positioned correctly, it engages easily into the socket.**

- 6 Align the notches in the processor with the socket keys on the ZIF socket. See Figure 3-24.
- 7 Install the processor in the socket. Keep the processor in level (see Figure 3-24) and insert it straight down into the socket. Allow the processor to float on the pins, allowing the processor shield to hold it in place.
- 8 Verify that the processor is properly aligned and seated.
- 9 Close the processor shield. See Figure 3-24.

- 10 Rotate the socket-release lever down until it snaps into place. See Figure 3-24.



**NOTE:** Your kit may contain a replacement heat sink if you are installing a processor that consumes additional power. The new heat sink may not appear different than the original one; however, it has improved thermal dissipation specifications and must be used.

- 11 Using a clean lint-free cloth, remove the thermal grease from the heat sink.



**CAUTION:** Applying too much thermal grease can result in excess grease coming in contact with and contaminating the processor socket.

- 12 Keeping the heat sink pin aligned with the slot on the system board, place the heat sink on the processor. See Figure 3-23.
- 13 Using a #2 Phillips screwdriver, tighten the two heat-sink retention screws. See Figure 3-23.
- 14 If applicable, replace the cooling fan assembly. See "Installing the Cooling Fan Assembly" on page 104.
- 15 Replace the cooling shroud. See "Installing the Cooling Shroud" on page 89.
- 16 If applicable, slide the front chassis assembly back. See "Front-Chassis Assembly" on page 90.
- 17 Close the system. See "Closing the System" on page 77.
- 18 Reconnect your system and peripherals to their electrical outlets, and turn on the system.
- 19 Press <F2> to enter the System Setup program, and check that the processor information matches the new system configuration. See "Entering the System Setup Program" on page 54.
- 20 Run the system diagnostics to verify that the new processor operates correctly.

For information about running the diagnostics, see "Running the Embedded System Diagnostics" on page 172.

# System Battery

## Replacing the System Battery

**⚠ WARNING:** There is a danger of a new battery exploding if it is incorrectly installed. Replace the battery only with the same or equivalent type recommended by the manufacturer. See your safety information for additional information.

**⚠ CAUTION:** Many repairs may only be done by a certified service technician. You should only perform troubleshooting and simple repairs as authorized in your product documentation, or as directed by the online or telephone service and support team. Damage due to servicing that is not authorized by Dell is not covered by your warranty. Read and follow the safety instructions that came with the product.

- 1 Turn off the system, including any attached peripherals, and disconnect the system from the electrical outlet.
- 2 Open the system. See "Opening the System" on page 76.

**Figure 3-26. Replacing the System Battery**

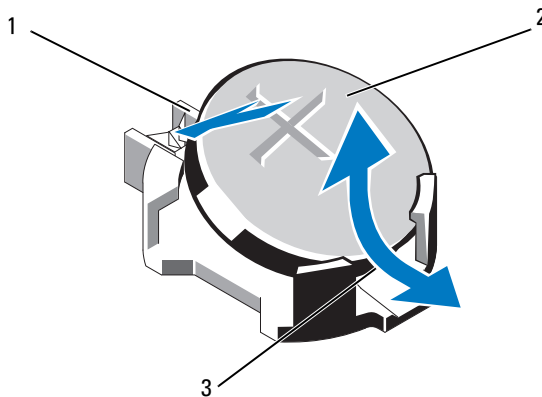

- |                                      |                  |
|--------------------------------------|------------------|
| 1 positive side of battery connector | 2 system battery |
| 3 negative side of battery connector |                  |

- 3 Locate the battery socket. See Figure 6-1.

- 4 If installed, remove the integrated storage controller card. See "Removing the Integrated Storage Controller Card" on page 115.



**CAUTION: To avoid damage to the battery connector, you must firmly support the connector while installing or removing a battery.**

- 5 To remove the battery, support the battery connector by pressing down firmly on the positive side of the connector.
- 6 Lift the battery out of the securing tabs at the negative side of the connector.
- 7 To install a new system battery, support the battery connector by pressing down firmly on the positive side of the connector.
- 8 Hold the battery with the "+" facing up and slide it under the securing tabs at the positive side of the connector.
- 9 Press the battery straight down into the connector until it snaps into place.
- 10 If applicable, replace the integrated storage controller card. "Installing the Integrated Storage Controller Card" on page 117.
- 11 Close the system. See "Closing the System" on page 77.
- 12 Reconnect the system to the electrical outlet and turn the system on, including any attached peripherals.
- 13 Enter the System Setup program to confirm that the battery is operating properly. See "Using the System Setup Program and UEFI Boot Manager" on page 53.
- 14 Enter the correct time and date in the System Setup program's **Time** and **Date** fields.
- 15 Exit the System Setup program.

# SAS Backplane

## Removing the SAS Backplane

**△ CAUTION: Many repairs may only be done by a certified service technician. You should only perform troubleshooting and simple repairs as authorized in your product documentation, or as directed by the online or telephone service and support team. Damage due to servicing that is not authorized by Dell is not covered by your warranty. Read and follow the safety instructions that came with the product.**

- 1 If installed, remove the front bezel. See "Removing the Front Bezel" on page 75.
- 2 Turn off the system and attached peripherals, and disconnect the system from the electrical outlet.
- 3 Open the system. See "Opening the System" on page 76.

**△ CAUTION: To prevent damage to the drives and backplane, you must remove the hard drives from the system before removing the backplane.**

**△ CAUTION: You must note the number of each hard drive and temporarily label them before removal so that you can replace them in the same locations.**

- 4 Remove the cooling shroud. See "Removing the Cooling Shroud" on page 88.
- 5 Remove all hard drives. See "Removing a Hard-Drive Carrier" on page 80.
- 6 Disconnect the SAS data cable(s) and power cable from the backplane. See Figure 3-27.
- 7 Push the blue release tabs in the direction of the arrows and slide the backplane upwards.
- 8 Pull the backplane away from the system until the securing slots on the backplane are free from the tabs on the front-chassis assembly.

**Figure 3-27. Removing and Installing a SAS Backplane**

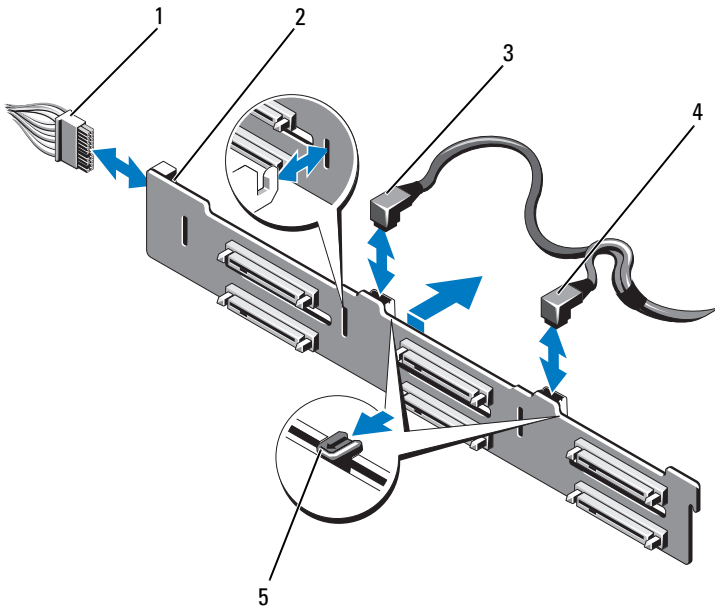

- |   |                  |   |               |
|---|------------------|---|---------------|
| 1 | power cable      | 2 | SAS backplane |
| 3 | SAS A cable      | 4 | SAS B cable   |
| 5 | release tabs (2) |   |               |

## Installing the SAS Backplane

- 1 Align the slots on the SAS backplane with the tabs on the front-chassis assembly.
- 2 Slide down the SAS backplane until the blue release tabs snap into place.
- 3 Connect the SAS data cable(s) and power cable to the backplane. See Figure 3-27.
- 4 Install the hard drives in their original locations. See "Installing a Hard-Drive Carrier" on page 81.
- 5 If required, route the power/data cables along the chassis wall. See "Front-Chassis Assembly" on page 90.
- 6 Replace the cooling shroud. See "Installing the Cooling Shroud" on page 89.
- 7 Close the system. See "Closing the System" on page 77.
- 8 Reconnect the system to its electrical outlet and turn the system on, including any attached peripherals.
- 9 If applicable, replace the front bezel. See "Installing the Front Bezel" on page 75.

## Power Distribution Board

### Removing the Power Distribution Board



**CAUTION: Many repairs may only be done by a certified service technician. You should only perform troubleshooting and simple repairs as authorized in your product documentation, or as directed by the online or telephone service and support team. Damage due to servicing that is not authorized by Dell is not covered by your warranty. Read and follow the safety instructions that came with the product.**

- 1 Turn off the system and attached peripherals, and disconnect the system from the electrical outlet.
- 2 Remove the power supplies from the system. See "Removing a Power Supply" on page 86.
- 3 Open the system. See "Opening the System" on page 76.

- 4** Remove the cooling fan assembly. See "Removing the Cooling Fan Assembly" on page 102.
- 5** If applicable, remove the cables on the power distribution board.
- 6** Separate the system board and the I/O board to disengage the interconnect between the power distribution board and the I/O board:
  - a** Slightly lift the tab on the high-speed connector to free the release levers. See Figure 3-30.
  - b** Push the release levers at an angle of 90 degrees away from the connector to separate the system board and the power distribution board from the I/O board. See Figure 3-30.
- 7** Press the release tab in the direction of the arrow and slide the board upwards. See Figure 3-28.
- 8** Pull the power distribution board up until the securing slots on the board are free from the tabs on the chassis. See Figure 3-28.



**Figure 3-28. Removing and Installing the Power Distribution Board**

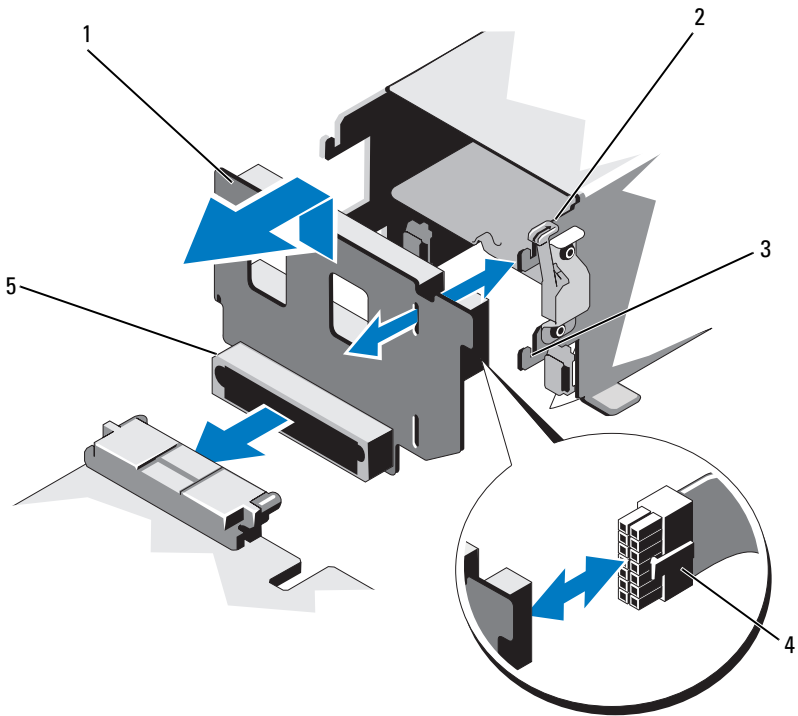

- |   |                                    |   |             |
|---|------------------------------------|---|-------------|
| 1 | power distribution board           | 2 | release tab |
| 3 | securing slot                      | 4 | power cable |
| 5 | power distribution board connector |   |             |

## Replacing the Power Distribution Board



**CAUTION: Many repairs may only be done by a certified service technician. You should only perform troubleshooting and simple repairs as authorized in your product documentation, or as directed by the online or telephone service and support team. Damage due to servicing that is not authorized by Dell is not covered by your warranty. Read and follow the safety instructions that came with the product.**

- 1 Unpack the new power distribution board assembly.
- 2 Align the securing slots on the power distribution board with the tabs on the chassis.
- 3 Pull the release tab slightly to the back of the system and slide the board down till it snaps into place. See Figure 3-28.
- 4 Connect the system board and the I/O board to engage the interconnect between the power distribution board and the I/O board:
  - a Align the guide pins on one half of the connector with the slots on the other half of the connector. See Figure 3-30.
  - b Push the release levers inward until they lock into position. See Figure 3-30.
- 5 Connect the cable to the power distribution board.
- 6 Replace the cooling fan assembly. See "Installing the Cooling Fan Assembly" on page 104.
- 7 Replace the power supplies in the system. See "Installing a Power Supply" on page 87.
- 8 Close the system. See "Closing the System" on page 77.
- 9 Reconnect the system to its electrical outlet and turn the system on, including any attached peripherals.

# Control Panel Assembly

## Removing the Control Panel Display Module



**CAUTION:** Many repairs may only be done by a certified service technician. You should only perform troubleshooting and simple repairs as authorized in your product documentation, or as directed by the online or telephone service and support team. Damage due to servicing that is not authorized by Dell is not covered by your warranty. Read and follow the safety instructions that came with the product.

- 1 If installed, remove the front bezel. See "Removing the Front Bezel" on page 75.
- 2 Turn off the system and attached peripherals, and disconnect the system from the electrical outlet.
- 3 Open the system. See "Opening the System" on page 76.
- 4 Disconnect the display module cable from the control panel board. See Figure 3-29.



**NOTE:** Using a small screwdriver or a knife raise the edges of the cable socket and release the cable clamp.

- 5 Using a knife or a small flat-blade screwdriver, insert the blade beneath the front panel of the display and slide the blade across the bottom to lift the panel outward. See Figure 3-29.
- 6 Bend the panel upward to access to the mounting screws.
- 7 Using a T10 Torx driver, remove the two screws that secure the display module to the system.
- 8 Remove the display module from the chassis cutout.

## Installing the Control Panel Display Module



**CAUTION:** Many repairs may only be done by a certified service technician. You should only perform troubleshooting and simple repairs as authorized in your product documentation, or as directed by the online or telephone service and support team. Damage due to servicing that is not authorized by Dell is not covered by your warranty. Read and follow the safety instructions that came with the product.

- 1 Insert the display module into the chassis cutout and secure the module with the two Torx screws. See Figure 3-29.
- 2 Attach the replacement panel to the front of the display module.
- 3 Connect the display module cable to the control panel board. See Figure 3-29.



**NOTE:** Ensure that you release the cable clamp before connecting the cable and then latch the clamp after connecting the cable.

- 4 Close the system. See "Closing the System" on page 77.
- 5 Reconnect the system to its electrical outlet and turn the system on, including any attached peripherals.
- 6 If applicable, replace the front bezel. See "Installing the Front Bezel" on page 75.

**Figure 3-29. Removing and Installing the Control Panel Display Module**

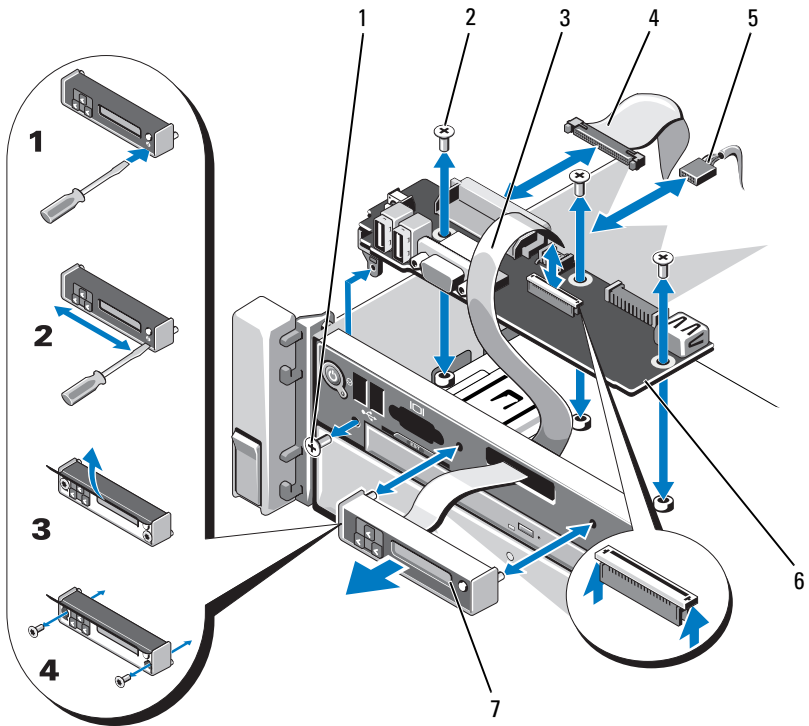



- 1 T8 Torx screw
- 3 display module cable
- 7 display module

- 2 T10 Torx screws (3)
- 4 control panel cable
- 6 control panel board

## Removing the Control Panel Board



**CAUTION:** Many repairs may only be done by a certified service technician. You should only perform troubleshooting and simple repairs as authorized in your product documentation, or as directed by the online or telephone service and support team. Damage due to servicing that is not authorized by Dell is not covered by your warranty. Read and follow the safety instructions that came with the product.

- 1 Turn off the system and attached peripherals, and disconnect the system from the electrical outlet.
- 2 Open the system. See "Opening the System" on page 76.
- 3 Disconnect the cables connected to the control panel board.  
See Figure 3-29.
  -  **NOTE:** Ensure that you release the cable clamp before connecting the cable and then latch the clamp after connecting the cable.
  -  **NOTE:** Note the routing of the cables on the side on the system as you remove them from the control panel board. You must route these cables properly when you replace them to prevent them from being pinched or crimped.
- 4 If applicable, remove the USB memory key. See "Internal USB Memory Key" on page 104.
- 5 Using a T10 Torx driver, remove the three screws that secure the control panel board to the front-chassis assembly. See Figure 3-29.
- 6 Using a T8 Torx driver, remove the screw that secures the control panel board on the front of the system. See Figure 3-29.
- 7 Slide the control panel assembly toward the back of the system and take it out.

## Installing the Control Panel Board



**CAUTION:** Many repairs may only be done by a certified service technician. You should only perform troubleshooting and simple repairs as authorized in your product documentation, or as directed by the online or telephone service and support team. Damage due to servicing that is not authorized by Dell is not covered by your warranty. Read and follow the safety instructions that came with the product.

- 1 Align the screw holes on the control panel board with the holes on the front-chassis assembly.
- 2 Using a T10 Torx driver, replace the three screws that secure the control panel board to the front-chassis assembly. See Figure 3-29.
- 3 Using a T8 Torx driver, replace the screw that secures the control panel board on the front of the system. See Figure 3-29.
- 4 If applicable, replace the USB memory key. See "Internal USB Memory Key" on page 104.
- 5 Connect all the cables to the control panel board.



**NOTE:** Ensure that you release the cable clamp before connecting the cable and then latch the clamp after connecting the cable.

- 6 If required, route the power/data cables along the chassis wall. See "Front-Chassis Assembly" on page 90.
- 7 Close the system. See "Closing the System" on page 77.
- 8 If applicable, replace the front bezel. See "Installing the Front Bezel" on page 75.
- 9 Reconnect the system to its electrical outlet and turn the system on, including any attached peripherals.

## System Board Assembly

The system board assembly is divided into two boards, which are interconnected by a high-speed connector.

- Processor board—It has the connectors for the memory modules, power supplies, and processors.
- I/O board—It has the connectors for expansion-card risers and expansion cards.

## Removing the System Board Assembly



**CAUTION:** Many repairs may only be done by a certified service technician. You should only perform troubleshooting and simple repairs as authorized in your product documentation, or as directed by the online or telephone service and support team. Damage due to servicing that is not authorized by Dell is not covered by your warranty. Read and follow the safety instructions that came with the product.



**CAUTION:** If you are using the Trusted Program Module (TPM) with an encryption key, you may be prompted to create a recovery key during program or system setup. Be sure to create and safely store this recovery key. If you replace this system board, you must supply the recovery key when you restart your system or program before you can access the encrypted data on your hard drives.



**NOTE:** You can remove or replace the processor board without removing the I/O board.

- 1 Turn off the system and attached peripherals, and disconnect the system from the electrical outlet.
- 2 If installed, remove the front bezel. See "Removing the Front Bezel" on page 75.
- 3 Open the system. See "Opening the System" on page 76.
- 4 Remove the cooling shroud. See "Removing the Cooling Shroud" on page 88.
- 5 Slide the front-chassis assembly away from the system. See "Front-Chassis Assembly" on page 90.
- 6 Remove the cable clamp. See Figure 3-10.
- 7 Remove the memory modules. See "Removing Memory Modules" on page 99.
- 8 Remove the cooling fan assembly. See "Removing the Cooling Fan Assembly" on page 102.



**WARNING:** The heat sink is hot to touch for some time after the system has been powered down. Make sure that you do not touch the heat sink(s) while removing the I/O board or the processor board.

- 9 Remove the heat sinks, processor blanks, and processors. See "Removing a Processor" on page 125.



- 10 If you are removing the I/O board, remove all expansion cards and the integrated storage controller card. See "Removing an Expansion Card" on page 110, and "Removing the Integrated Storage Controller Card" on page 115.
- 11 If you are removing the I/O board, remove the expansion card risers. See "Removing Expansion-Card Riser 1" on page 111 and "Removing Expansion-Card Riser 2" on page 113.
- 12 If applicable, remove the NIC hardware key from the I/O board. See "Internal NIC Hardware Key" on page 105.
- 13 Disconnect the cables from the system board assembly, SAS backplane, control panel board, the optical drive, and other components.
- 14 Lift the tab on the high speed connector to free the release levers. See Figure 3-30.
- 15 Push the release levers at an angle of 90 degrees away from the connector to separate the processor board from the I/O board. See Figure 3-30.
- 16 Push the processor board toward the front of the system to free the guide pins on one half of the connector from the slots on the other half of the connector.



**NOTE:** The power distribution board connector disengages from the processor board when the processor board is separated from the I/O board.



**CAUTION:** Do not lift the system board assembly by grasping a memory module, processor, or other components.

- 17 Hold the processor board by the handle and the board edge (see Figure 3-30). Angle the processor board out toward the back of the system and lift the board out of the chassis.
- 18 To remove the I/O board, pull the release pin and slide the I/O board toward the front of the system. Carefully lift the I/O board out of the chassis.

**Figure 3-30. Removing and Installing the System Board Assembly**

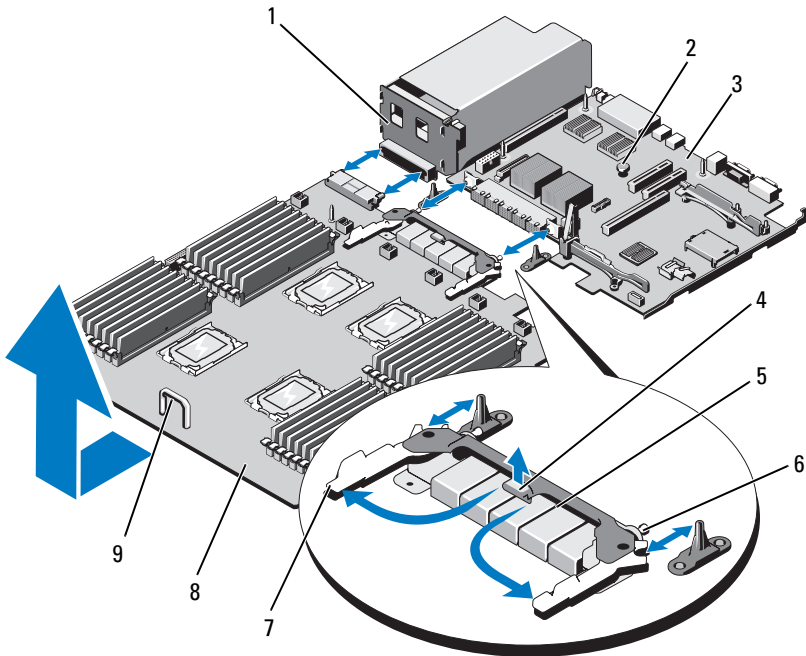

- |   |                          |   |                 |
|---|--------------------------|---|-----------------|
| 1 | power distribution board | 2 | release pin     |
| 3 | I/O board                | 4 | tab             |
| 5 | high-speed connector     | 6 | guide pins (2)  |
| 7 | release levers (2)       | 8 | processor board |
| 9 | handle                   |   |                 |

## Installing the System Board Assembly

- 1** Unpack the new system board assembly. If the I/O board was not removed go to step 5.
- 2** Grasp the I/O board by its edge and the release pin and lower it into the chassis.
- 3** Position the I/O board to the bottom of the chassis until it lays completely flat.
- 4** Slide the I/O board toward the back of the system, inserting the connectors into the cutouts on the chassis back panel.
- 5** Holding by the handle and the board edge of the processor board (see Figure 3-30), lower the processor board into the chassis. Lower the processor board to the bottom of the chassis until it lays completely flat.
- 6** Rotate the levers outward 90 degrees and slide the processor board backward so that the guide pins on one half of the high-speed connector engages with the slots on the other half of the connector. See Figure 3-30.
- 7** Push the release levers inward until they lock into position. See Figure 3-30.
- 8** Replace the processors and heat sinks on the new processor board. See "Installing a Processor" on page 129.
- 9** Replace the memory modules. See "Installing Memory Modules" on page 97.
- 10** Replace the cable clamp. See Figure 3-10.
- 11** Replace the cooling fan assembly. See "Installing the Cooling Fan Assembly" on page 104.
- 12** If applicable, replace the NIC hardware key on the I/O board. See "Internal NIC Hardware Key" on page 105.
- 13** If applicable, replace the expansion card risers. See "Installing Expansion-Card Riser 1" on page 113 and "Installing Expansion-Card Riser 2" on page 114.
- 14** If applicable, replace all expansion cards and the integrated storage controller card. See "Installing an Expansion Card" on page 108 and "Installing the Integrated Storage Controller Card" on page 117.
- 15** Slide the front-chassis assembly back into the system. See "Front-Chassis Assembly" on page 90.

- 16** Connect the cables to the system board assembly, SAS backplane, control panel board, and the optical drive.
- 17** Route the power/data cables along the chassis wall. See "Front-Chassis Assembly" on page 90.
- 18** Replace the cooling shroud. See "Installing the Cooling Shroud" on page 89.
- 19** Close the system. See "Closing the System" on page 77.
- 20** If applicable, replace the front bezel. See "Installing the Front Bezel" on page 75.
- 21** Reconnect the system to its electrical outlet and turn the system on, including any attached peripherals.

# Troubleshooting Your System

## Safety First—For You and Your System

**△ CAUTION:** Many repairs may only be done by a certified service technician. You should only perform troubleshooting and simple repairs as authorized in your product documentation, or as directed by the online or telephone service and support team. Damage due to servicing that is not authorized by Dell is not covered by your warranty. Read and follow the safety instructions that came with the product.

## Troubleshooting System Startup Failure

If your system halts during startup prior to video output or LCD messaging, especially after installing an operating system or reconfiguring your system's hardware, check for the following conditions:

- If you boot the system to the BIOS boot mode after installing an operating system from the UEFI Boot Manager, the system will hang. The reverse is also true. You must boot to the same boot mode in which you installed the operating system. See "Using the System Setup Program and UEFI Boot Manager" on page 53.
- Invalid memory configurations could cause the system to halt at startup without any video output. See "System Memory" on page 92.

For all other startup issues, note the LCD panel messages and any system messages that appear onscreen. For more information, see "LCD Status Messages" on page 22 and "System Messages" on page 38.

## Troubleshooting External Connections

Ensure that all external cables are securely attached to the external connectors on your system before troubleshooting any external devices. See Figure 1-1 and Figure 1-3 for the front- and back-panel connectors on your system.

## Troubleshooting the Video Subsystem

- 1 Check the system and power connections to the monitor.
- 2 Check the video interface cabling from the system to the monitor.
- 3 If two monitors are attached to the system, disconnect one monitor. The system supports only one monitor attached to either the front or rear video connector.
- 4 If the problem persists, see "Getting Help" on page 185.

## Troubleshooting a USB Device

- 1 Use the following steps to troubleshoot a USB keyboard and/or mouse. For other USB devices, go to step 2.
  - a Disconnect the keyboard and mouse cables from the system briefly and reconnect them.
  - b Connect the keyboard and mouse to the USB port(s) on the opposite side of the system.

If the problem is resolved, restart the system, enter the System Setup program, and check if the nonfunctioning USB ports are enabled.
  - c Replace the keyboard/mouse with another working keyboard/mouse.

If the problem is resolved, replace the faulty keyboard/mouse.

If the problem is not resolved, proceed to the next step to begin troubleshooting the other USB devices attached to the system.
- 2 Power down all attached USB devices and disconnect them from the system.
- 3 Restart the system and, if your keyboard is functioning, enter the system setup program. Verify that all USB ports are enabled. See "Integrated Devices Screen" on page 60.

If your keyboard is not functioning, you can also use remote access. If the system is not accessible, see "Disabling a Forgotten Password" on page 183 for instructions on setting the NVRAM\_CLR jumper inside your system and restoring the BIOS to the default settings.

- 4 Reconnect and power on each USB device one at a time.
- 5 If a device causes the same problem, power down the device, replace the USB cable, and power up the device.

If the problem persists, replace the device.

If all troubleshooting fails, see "Getting Help" on page 185.

## Troubleshooting a Serial I/O Device

- 1 Turn off the system and any peripheral devices connected to the serial port.
- 2 Swap the serial interface cable with a cable in good condition, and turn on the system and the serial device.

If the problem is resolved, replace the interface cable.

- 3 Turn off the system and the serial device, and swap the device with a comparable device.

- 4 Turn on the system and the serial device.

If the problem is resolved, replace the serial device.

If the problem persists, see "Getting Help" on page 185.

## Troubleshooting a NIC

- 1 Run the appropriate online diagnostic test. See "Using Online Diagnostics" on page 171.
- 2 Restart the system and check for any system messages pertaining to the NIC controller.
- 3 Check the appropriate indicator on the NIC connector. See "NIC Indicator Codes" on page 20.
  - If the link indicator does not light, check all cable connections.
  - If the activity indicator does not light, the network driver files might be damaged or missing.

Remove and reinstall the drivers if applicable. See the NIC's documentation.

- Change the autonegotiation setting, if possible.
- Use another connector on the switch or hub.

If you are using a NIC card instead of an integrated NIC, see the documentation for the NIC card.

- 4 Ensure that the appropriate drivers are installed and the protocols are bound. See the NIC's documentation.
- 5 Enter the System Setup program and confirm that the NIC ports are enabled. See "Integrated Devices Screen" on page 60.
- 6 Ensure that the NICs, hubs, and switches on the network are all set to the same data transmission speed and duplex mode. See the documentation for each network device.
- 7 Ensure that all network cables are of the proper type and do not exceed the maximum length.

If all troubleshooting fails, see "Getting Help" on page 185.

## Troubleshooting a Wet System



**CAUTION: Many repairs may only be done by a certified service technician. You should only perform troubleshooting and simple repairs as authorized in your product documentation, or as directed by the online or telephone service and support team. Damage due to servicing that is not authorized by Dell is not covered by your warranty. Read and follow the safety instructions that came with the product.**

- 1 Turn off the system and attached peripherals, and disconnect the system from the electrical outlet.
- 2 Open the system. See "Opening the System" on page 76.
- 3 Disassemble components from the system. See "Installing System Components" on page 73.
  - Hard drives
  - Cooling shroud
  - Cooling fan assembly
  - SD cards
  - USB memory key



- NIC hardware key
  - Internal dual SD module
  - Expansion cards and both expansion-card risers
  - Integrated storage controller
  - iDRAC6 Enterprise card
  - Power supplies
  - Processors and heat sinks
- 4 Let the system dry thoroughly for at least 24 hours.
  - 5 Reinstall the components you removed in step 3.
  - 6 Close the system. See "Closing the System" on page 77.
  - 7 Reconnect the system to the electrical outlet, and turn on the system and attached peripherals.  
If the system does not start properly, see "Getting Help" on page 185.
  - 8 Run the appropriate online diagnostic test. See "Using Online Diagnostics" on page 171.  
If the tests fail, see "Getting Help" on page 185.

## Troubleshooting a Damaged System



**CAUTION:** Many repairs may only be done by a certified service technician. You should only perform troubleshooting and simple repairs as authorized in your product documentation, or as directed by the online or telephone service and support team. Damage due to servicing that is not authorized by Dell is not covered by your warranty. Read and follow the safety instructions that came with the product.

- 1 Turn off the system and attached peripherals, and disconnect the system from the electrical outlet.
- 2 Open the system. See "Opening the System" on page 76.
- 3 Ensure that the following components are properly installed:
  - Hard drives
  - Cooling fan assembly
  - SD cards

- USB memory key
  - NIC hardware key
  - Internal Dual SD Module
  - Expansion cards and both expansion-card risers
  - Integrated storage controller
  - iDRAC6 Enterprise card
  - Power supplies
  - Processors and heat sinks
- 4 Ensure that all cables are properly connected.
  - 5 Close the system. See "Closing the System" on page 77.
  - 6 Run the system board tests in the system diagnostics. See "Running the Embedded System Diagnostics" on page 172.
- If the tests fail, see "Getting Help" on page 185.

## Troubleshooting the System Battery



**NOTE:** If the system is turned off for long periods of time (for weeks or months), the NVRAM may lose its system configuration information. This situation is caused by a defective battery.

- 1 Re-enter the time and date through the System Setup program. See "Using the System Setup Program and UEFI Boot Manager" on page 53.
- 2 Turn off the system and disconnect it from the electrical outlet for at least one hour.
- 3 Reconnect the system to the electrical outlet and turn on the system.
- 4 Enter the System Setup program.

If the date and time are not correct in the System Setup program, replace the battery. See "Replacing the System Battery" on page 132.



**NOTE:** Some software may cause the system time to speed up or slow down. If the system seems to operate normally except for the time kept in the System Setup program, the problem may be caused by software rather than by a defective battery.

If the problem is not resolved by replacing the battery, see "Getting Help" on page 185.

## Troubleshooting Power Supplies

 **CAUTION:** At least one power supply must be installed for the system to operate. Operating the system with only one power supply installed for extended periods of time can cause the system to overheat.

- 1 Identify the faulty power supply by the power supply's fault indicator. See "Power Indicator Codes" on page 21.
- 2 Reseat the power supply by removing and reinstalling it. See "Removing a Power Supply" on page 85 and "Installing a Power Supply" on page 87.

 **NOTE:** After installing a power supply, allow several seconds for the system to recognize the power supply and to determine if it is working properly. The power indicator turns green to signify that the power supply is functioning properly.

If the problem persists, replace the faulty power supply.

- 3 If the problem persists, see "Getting Help" on page 185.

## Troubleshooting System Cooling Problems

 **CAUTION:** Many repairs may only be done by a certified service technician. You should only perform troubleshooting and simple repairs as authorized in your product documentation, or as directed by the online or telephone service and support team. Damage due to servicing that is not authorized by Dell is not covered by your warranty. Read and follow the safety instructions that came with the product.

Ensure that none of the following conditions exist:

- System cover, cooling shroud, drive blank, memory-module blank, power-supply blank, or PCIe slot filler bracket is removed.
- Ambient temperature is too high. See your *Getting Started Guide* for your system's operating temperature requirements.
- External airflow is obstructed.
- Cables inside the system obstruct airflow.
- An individual cooling fan is removed or has failed. See "Troubleshooting a Fan" on page 158.
- The expansion card installation guidelines have not been followed. See "Expansion Card Installation Guidelines" on page 107.

## Troubleshooting a Fan



**CAUTION:** Many repairs may only be done by a certified service technician. You should only perform troubleshooting and simple repairs as authorized in your product documentation, or as directed by the online or telephone service and support team. Damage due to servicing that is not authorized by Dell is not covered by your warranty. Read and follow the safety instructions that came with the product.

- 1 Open the system. See "Opening the System" on page 76.



**CAUTION:** The cooling fans are hot-swappable. To maintain proper cooling while the system is on, only replace one fan at a time.

- 2 Locate the faulty fan indicated by the LCD panel or the diagnostic software.
- 3 Remove and reseal the fan. See "Removing a Cooling Fan" on page 101 and "Installing a Cooling Fan" on page 103.



**NOTE:** Wait at least 30 seconds for the system to recognize the fan and determine whether it is working properly.

- 4 If the problem is not resolved, install a new fan. See "Removing a Cooling Fan" on page 101 and "Installing a Cooling Fan" on page 103.

If the replacement fan is working properly, close the system. See "Closing the System" on page 77.

If the replacement fan does not operate, see "Getting Help" on page 185.

# Troubleshooting System Memory

 **CAUTION:** Many repairs may only be done by a certified service technician. You should only perform troubleshooting and simple repairs as authorized in your product documentation, or as directed by the online or telephone service and support team. Damage due to servicing that is not authorized by Dell is not covered by your warranty. Read and follow the safety instructions that came with the product.

 **NOTE:** Invalid memory configurations can cause your system to halt at startup without video output. See "General Memory Module Installation Guidelines" on page 93 and verify that your memory configuration complies with all applicable guidelines.

- 1 If the system is operational, run the appropriate online diagnostic test. See "Using Online Diagnostics" on page 171.

If diagnostics indicates a fault, follow the corrective actions provided by the diagnostic program.

- 2 If the system is not operational, turn off the system and attached peripherals, and unplug the system from the power source. Wait at least 10 seconds and then reconnect the system to power.
- 3 Turn on the system and attached peripherals and note the messages on the screen.

Go to step 16 if an error message appears indicating a fault with a specific memory module.

- 4 Enter the System Setup program and check the system memory setting. See "Memory Settings Screen" on page 57. Make any changes to the memory settings, if needed.

If the memory settings match the installed memory but a problem is still indicated, go to step 16.

- 5 Turn off the system and attached peripherals, and disconnect the system from the electrical outlet.
- 6 Open the system. See "Opening the System" on page 76.
- 7 If applicable, slide the front chassis assembly. See "Front-Chassis Assembly" on page 90.
- 8 If applicable, remove the cooling shroud. See "Removing the Cooling Shroud" on page 88.

- 9** Check the memory channels and ensure that they are populated correctly. See "General Memory Module Installation Guidelines" on page 93.
- 10** Reseat the memory modules in their sockets. See "Installing Memory Modules" on page 98.
- 11** If applicable, replace the cooling shroud. See "Installing the Cooling Shroud" on page 89.
- 12** If applicable, slide the front chassis back. See "Front-Chassis Assembly" on page 90.
- 13** Close the system. See "Closing the System" on page 77.
- 14** Reconnect the system to its electrical outlet, and turn on the system and attached peripherals.
- 15** Enter the System Setup program and check the system memory setting. See "Memory Settings Screen" on page 57.  
If the problem is not resolved, proceed with the next step.
- 16** If a diagnostic test or error message indicates a specific memory module as faulty, swap or replace the module.
- 17** Open the system. See "Opening the System" on page 76.
- 18** If applicable, move the front chassis assembly. See "Front-Chassis Assembly" on page 90.
- 19** If applicable, remove the cooling shroud. See "Removing the Cooling Shroud" on page 88.
- 20** To troubleshoot an unspecified faulty memory module, replace the memory module in the first DIMM socket with a module of the same type and capacity. See "Installing Memory Modules" on page 98.
- 21** If applicable, replace the cooling shroud. See "Installing the Cooling Shroud" on page 89.
- 22** If applicable, slide the front chassis back. See "Front-Chassis Assembly" on page 90.
- 23** Close the system. See "Closing the System" on page 77.
- 24** Reconnect the system to its electrical outlet, and turn on the system and attached peripherals.

- 25 As the system boots, observe any error message that appears and the diagnostic indicators on the front of the system.
- 26 If the memory problem is still indicated, repeat step 16 through step 23 for each memory module installed.  
If the problem persists after all memory modules have been checked, see "Getting Help" on page 185.

## Troubleshooting an Internal USB Key



**CAUTION: Many repairs may only be done by a certified service technician. You should only perform troubleshooting and simple repairs as authorized in your product documentation, or as directed by the online or telephone service and support team. Damage due to servicing that is not authorized by Dell is not covered by your warranty. Read and follow the safety instructions that came with the product.**

- 1 Enter the System Setup program and ensure that the internal USB key port is enabled. See "Integrated Devices Screen" on page 60.
- 2 Turn off the system and attached peripherals, and disconnect the system from the electrical outlet.
- 3 Open the system. See "Opening the System" on page 76.
- 4 If applicable, move the front chassis assembly. See "Front-Chassis Assembly" on page 90.
- 5 If applicable, remove the cooling shroud. See "Removing the Cooling Shroud" on page 88.
- 6 Locate the USB key and reseal it. See "Internal USB Memory Key" on page 105.
- 7 If applicable, replace the cooling shroud. See "Installing the Cooling Shroud" on page 89.
- 8 If applicable, slide the front chassis back. See "Front-Chassis Assembly" on page 90.
- 9 Close the system. See "Closing the System" on page 77.
- 10 Turn on the system and attached peripherals and check if the USB key is functioning.
- 11 If the problem is not resolved, repeat step 2 and step 3.

- 12 Insert a different USB key that you know works properly.
- 13 Close the system. See "Closing the System" on page 77.
- 14 Turn on the system and attached peripherals and check if the USB key is functioning.  
If the problem is not resolved, see "Getting Help" on page 185.

## Troubleshooting an SD Card

 **CAUTION: Many repairs may only be done by a certified service technician. You should only perform troubleshooting and simple repairs as authorized in your product documentation, or as directed by the online or telephone service and support team. Damage due to servicing that is not authorized by Dell is not covered by your warranty. Read and follow the safety instructions that came with the product.**

- 1 Enter the System Setup program and ensure that the internal SD card port is enabled. See "Integrated Devices Screen" on page 60.
- 2 Turn off the system, including any attached peripherals, and disconnect the system from the electrical outlet.
- 3 Open the system. See "Opening the System" on page 76.
- 4 Reseat the SD module cable. See "Installing the Internal Dual SD Module" on page 125.

 **CAUTION: If the Redundancy option is set to Mirror Mode in the Integrated Devices screen of the system setup, you must follow the instructions in step 5 to step 9 to avoid loss of data. If the Redundancy option is set to Disabled, proceed to step 10.**

 **NOTE:** When an SD card failure occurs, the internal dual SD module controller notifies the system. On the next reboot, the system prompts you with a message indicating the failure.

- 5 If SD card 1 has failed, remove the card from SD card slot 1. See "Removing the Internal Dual SD Module" on page 124. If SD card 2 has failed, install a new SD card in SD card slot 2 and proceed to step 8.
- 6 Remove the card present in SD card slot 2 and insert it into SD card slot 1. See "Removing the Internal Dual SD Module" on page 124 and "Installing the Internal Dual SD Module" on page 125.
- 7 Insert the new SD card into SD card slot 2. See Figure 3-22.



- 8 Close the system. See "Closing the System" on page 77.
- 9 Turn on the system and attached peripherals and check if the SD card is functioning.
- 10 Insert a different SD card that you know works properly.
- 11 Close the system. See "Closing the System" on page 77.
- 12 Turn on the system and attached peripherals and check if the SD card is functioning.

If the problem is not resolved, see "Getting Help" on page 185.

## Troubleshooting an Optical Drive



**CAUTION: Many repairs may only be done by a certified service technician. You should only perform troubleshooting and simple repairs as authorized in your product documentation, or as directed by the online or telephone service and support team. Damage due to servicing that is not authorized by Dell is not covered by your warranty. Read and follow the safety instructions that came with the product.**

- 1 If applicable, remove the bezel. See "Removing the Front Bezel" on page 75.
- 2 Try using a different CD or DVD.
- 3 Enter the System Setup program and ensure that the integrated SATA controller and the drive's SATA port are enabled. See "Using the System Setup Program and UEFI Boot Manager" on page 53.
- 4 Run the appropriate online diagnostic test. See "Using Online Diagnostics" on page 171.
- 5 Turn off the system and attached peripherals, and disconnect the system from the electrical outlet.
- 6 Open the system. See "Opening the System" on page 76.
- 7 Ensure that the interface cable is securely connected to the optical drive and to the system board. See "Optical Drive" on page 83.
- 8 Ensure that a power cable is properly connected to the drive.

- 9 Close the system. See "Closing the System" on page 77.
- 10 Reconnect the system to the electrical outlet, and turn on the system and attached peripherals.

If the problem is not resolved, see "Getting Help" on page 185.

## Troubleshooting a Hard Drive

 **CAUTION:** Many repairs may only be done by a certified service technician. You should only perform troubleshooting and simple repairs as authorized in your product documentation, or as directed by the online or telephone service and support team. Damage due to servicing that is not authorized by Dell is not covered by your warranty. Read and follow the safety instructions that came with the product.

 **CAUTION:** This troubleshooting procedure can destroy data stored on the hard drive. Before you proceed, back up all files on the hard drive.

- 1 Run the appropriate online diagnostics test. See "Using Online Diagnostics" on page 171.

Depending on the results of the diagnostics test, proceed as needed through the following steps.

- 2 If applicable, remove the bezel. See "Removing the Front Bezel" on page 75.
- 3 If your system has a RAID controller and your hard drives are configured in a RAID array, perform the following steps.
  - a Restart the system and enter the host adapter configuration utility program by pressing <Ctrl><R> for a PERC controller or <Ctrl><C> for a SAS controller.  
See the documentation supplied with the host adapter for information about the configuration utility.
  - b Ensure that the hard drive(s) have been configured correctly for the RAID array.
  - c Take the hard drive offline and reseal the drive. See "Removing a Hard-Drive Carrier" on page 80.
  - d Exit the configuration utility and allow the system to boot to the operating system.

- 4 Ensure that the required device drivers for your controller card are installed and are configured correctly. See the operating system documentation for more information.
- 5 Restart the system, enter the System Setup program, and verify that the controller is enabled and the drives appear in the System Setup program. See "Using the System Setup Program and UEFI Boot Manager" on page 53.

If the problem persists, see "Troubleshooting a Storage Controller" on page 166.

## Troubleshooting a Storage Controller



**NOTE:** When troubleshooting a SAS or PERC controller, also see the documentation for your operating system and the controller.

- 1 Run the appropriate online diagnostic test. See "Using Online Diagnostics" on page 171.
- 2 Enter the System Setup program and ensure that the SAS or PERC controller is enabled. See "Using the System Setup Program and UEFI Boot Manager" on page 53.
- 3 Restart the system and press the applicable key sequence to enter the configuration utility program:
  - <Ctrl><C> for a SAS controller
  - <Ctrl><R> for PERC controller

See the controller's documentation for information about configuration settings.

- 4 Check the configuration settings, make any necessary corrections, and restart the system.



**CAUTION:** Many repairs may only be done by a certified service technician. You should only perform troubleshooting and simple repairs as authorized in your product documentation, or as directed by the online or telephone service and support team. Damage due to servicing that is not authorized by Dell is not covered by your warranty. Read and follow the safety instructions that came with the product.

- 5 Turn off the system and attached peripherals, and disconnect the system from its electrical outlet.

- 6 Open the system. See "Opening the System" on page 76.
- 7 Ensure that the controller card is firmly seated into the system board connector. See "VFlash Media (Optional)" on page 123.
- 8 If you have a PERC controller with battery-backed cache, ensure that the RAID battery is properly connected and, if applicable, the memory module on the PERC card is properly seated.
- 9 Verify that the cable connections between the SAS backplane and the integrated storage controller are correct. See "Installing the Integrated Storage Controller Card" on page 118 and Figure 6-4.  
Ensure that the cables are firmly connected to the storage controller and the SAS backplane board.
- 10 Close the system. See "Closing the System" on page 77.
- 11 Reconnect the system to its electrical outlet, and turn on the system and attached peripherals.  
If the problem persists, see "Getting Help" on page 185.

## Troubleshooting Expansion Cards



**CAUTION:** Many repairs may only be done by a certified service technician. You should only perform troubleshooting and simple repairs as authorized in your product documentation, or as directed by the online or telephone service and support team. Damage due to servicing that is not authorized by Dell is not covered by your warranty. Read and follow the safety instructions that came with the product.



**NOTE:** When troubleshooting an expansion card, see the documentation for your operating system and the expansion card.

- 1 Run the appropriate online diagnostic test. See "Using Online Diagnostics" on page 171.
- 2 Turn off the system and attached peripherals, and disconnect the system from the electrical outlet.
- 3 Open the system. See "Opening the System" on page 76.
- 4 Verify that the installed expansion cards are compliant with the expansion card installation guidelines. See "Expansion Card Installation Guidelines" on page 107.

- 5** Ensure that each expansion card is firmly seated in its connector. See "Installing an Expansion Card" on page 109.
- 6** Close the system. See "Closing the System" on page 77.
- 7** Reconnect the system to the electrical outlet, and turn on the system and attached peripherals.
- 8** If the problem is not resolved, turn off the system and attached peripherals, and disconnect the system from the electrical outlet.
- 9** Open the system. See "Opening the System" on page 76.
- 10** Remove all expansion cards installed in the system. See "Removing an Expansion Card" on page 111.
- 11** Close the system. See "Closing the System" on page 77.
- 12** Reconnect the system to the electrical outlet, and turn on the system and attached peripherals.
- 13** Run the appropriate online diagnostic test.  
If the tests fail, see "Getting Help" on page 185.
- 14** For each expansion card you removed in step 10, perform the following steps:
  - a** Turn off the system and attached peripherals, and disconnect the system from the electrical outlet.
  - b** Open the system. See "Opening the System" on page 76.
  - c** Reinstall one of the expansion cards.
  - d** Close the system. See "Closing the System" on page 77.
  - e** Run the appropriate diagnostic test.  
If the tests fail, see "Getting Help" on page 185.

# Troubleshooting the Processors



**CAUTION: Many repairs may only be done by a certified service technician. You should only perform troubleshooting and simple repairs as authorized in your product documentation, or as directed by the online or telephone service and support team. Damage due to servicing that is not authorized by Dell is not covered by your warranty. Read and follow the safety instructions that came with the product.**

- 1 Run the appropriate online diagnostics test. See "Using Online Diagnostics" on page 171.
- 2 Turn off the system and attached peripherals, and disconnect the system from the electrical outlet.
- 3 Open the system. See "Opening the System" on page 76.
- 4 Remove the cooling fan assembly. See "Removing the Cooling Fan Assembly" on page 103.
- 5 Ensure that each processor and heat sink are properly installed. See "Removing a Processor" on page 126.
- 6 Install the cooling fan assembly. See "Installing the Cooling Fan Assembly" on page 104.
- 7 Close the system. See "Closing the System" on page 77.
- 8 Reconnect the system to the electrical outlet, and turn on the system and attached peripherals.
- 9 Run the appropriate online diagnostic test.
- 10 Turn off the system and attached peripherals, and disconnect the system from the electrical outlet.
- 11 Open the system. See "Opening the System" on page 76.
- 12 Remove the cooling fan assembly. See "Removing the Cooling Fan Assembly" on page 103.
- 13 Remove all processors except for processor 1 and processor 2. See "Removing a Processor" on page 126.
- 14 Install the cooling fan assembly. See "Installing the Cooling Fan Assembly" on page 104.
- 15 Close the system. See "Closing the System" on page 77.

- 16** Reconnect the system to the electrical outlet, and turn on the system and attached peripherals.
- 17** Run the appropriate online diagnostic test.  
If the test fails, the processor is faulty. See "Getting Help" on page 185.
- 18** Turn off the system and attached peripherals, and disconnect the system from the electrical outlet.
- 19** Open the system. See "Opening the System" on page 76.
- 20** Remove the cooling fan assembly. See "Removing the Cooling Fan Assembly" on page 103.
- 21** Replace processor 1 and processor 2 with processor 3 and processor 4. See "Removing a Processor" on page 126.
- 22** Install the cooling fan assembly. See "Installing the Cooling Fan Assembly" on page 104.
- 23** Close the system. See "Closing the System" on page 77.
- 24** Repeat step 15 through step 17.  
If your system has more than two processors, continue installing and testing each processor in the processor 1 slot until you determine the faulty processor, and then replace the faulty processor. See "Getting Help" on page 185.  
  
If you have tested all the processors and the problem persists, the system board is faulty. See "Getting Help" on page 185.





# Running the System Diagnostics

If you experience a problem with your system, run the diagnostics before calling for technical assistance. The purpose of the diagnostics is to test your system's hardware without requiring additional equipment or risking data loss. If you are unable to fix the problem yourself, service and support personnel can use diagnostics test results to help you solve the problem.

## Using Online Diagnostics

To assess a system problem, first use the online diagnostics. Online Diagnostics is a suite of diagnostic programs, or test modules, that include diagnostic tests on chassis and storage components such as hard drives, physical memory, communications and printer ports, NICs, CMOS, and more. If you are unable to identify the problem using the online diagnostics, then use the embedded system diagnostics.

The files required to run the online diagnostics for systems running supported Microsoft® Windows® and Linux operating systems are available at [support.dell.com](http://support.dell.com) and on the CDs that came with your system. For information about using diagnostics, see the *Dell Online Diagnostics User's Guide*.

## Embedded System Diagnostics Features

The system diagnostics provides a series of menus and options for particular device groups or devices. The system diagnostics menus and options allow you to:

- Run tests individually or collectively
- Control the sequence of tests
- Repeat tests
- Display, print, or save test results
- Temporarily suspend testing if an error is detected or terminate testing when a user-defined error limit is reached
- View help messages that briefly describe each test and its parameters

- View status messages that inform you if tests are completed successfully
- View error messages that inform you of problems encountered during testing

## When to Use the Embedded System Diagnostics

If a major component or device in the system does not operate properly, component failure may be indicated. As long as the processor and the system's input/output devices are functioning, you can use the embedded system diagnostics to help identify the problem.

## Running the Embedded System Diagnostics

The embedded system diagnostics program is run from the Life Cycle Controller screen.

 **CAUTION: Use the embedded system diagnostics to test only your system. Using this program with other systems may cause invalid results or error messages.**

- 1 As the system boots, press <F10>.
- 2 Click **Diagnostics** in the left pane and click **Launch Diagnostics** in the right pane.

The **Diagnostics** menu allows you to run all or specific diagnostics tests or to exit.

## System Diagnostics Testing Options

Click the testing option in the **Main Menu** window.

Testing Option	Function
Express Test	Performs a quick check of the system. This option runs device tests that do not require user interaction.
Extended Test	Performs a more thorough check of the system. This test can take an hour or longer.
Custom Test	Tests a particular device.
Information	Displays test results.

## Using the Custom Test Options

When you select **Custom Test** in the **Main Menu** window, the **Customize** window allows you to select the device(s) to be tested, select specific options for testing, and view the test results.

### Selecting Devices for Testing

The left side of the **Customize** window lists devices that can be tested. Click the (+) next to a device or module to view its components. Click (+) on any component to view the tests that are available. Clicking a device, rather than its components, selects all of the components of the device for testing.



**NOTE:** After you select all the devices and components that you want to test, highlight **All Devices** and then click **Run Tests**.

### Selecting Diagnostics Options

From the **Diagnostics Options** area, select the test(s) you want to run on a device.

- **Non-Interactive Tests Only** — Runs only tests that require no user intervention.
- **Quick Tests Only** — Runs only the quick tests on the device.
- **Show Ending Timestamp** — Time stamps the test log.
- **Test Iterations** — Selects the number of times the test is run.
- **Log output file pathname** — Enables you to specify the diskette drive or USB memory key where the test log file is saved. You cannot save the file to a hard drive.

### Viewing Information and Results

The following tabs in the **Customize** window provide information about the test and the test results.

- **Results** — Displays the test that ran and the result.
- **Errors** — Displays any errors that occurred during the test.
- **Help** — Displays information about the currently selected device, component, or test.

- **Configuration** — Displays basic configuration information about the currently selected device.
- **Parameters** — Displays parameters that you can set for the test.





# 6

## Jumpers and Connectors

### System Board Jumper

For information on disabling a password, see "Disabling a Forgotten Password" on page 183.

**Table 6-1. System Board Jumper Settings**

Jumper	Setting	Description
PW RD_EN	 (default)	The password feature is enabled (pins 2-4)
		The password feature is disabled, and iDRAC6 local access is unlocked at the next AC power cycle (pins 4-6)
NVRAM_CLR	 (default)	The configuration settings are retained at system boot (pins 3-5)
		The configuration settings are cleared at the next system boot (pins 1-3)

# System Board Connectors

Figure 6-1. System Board Connectors

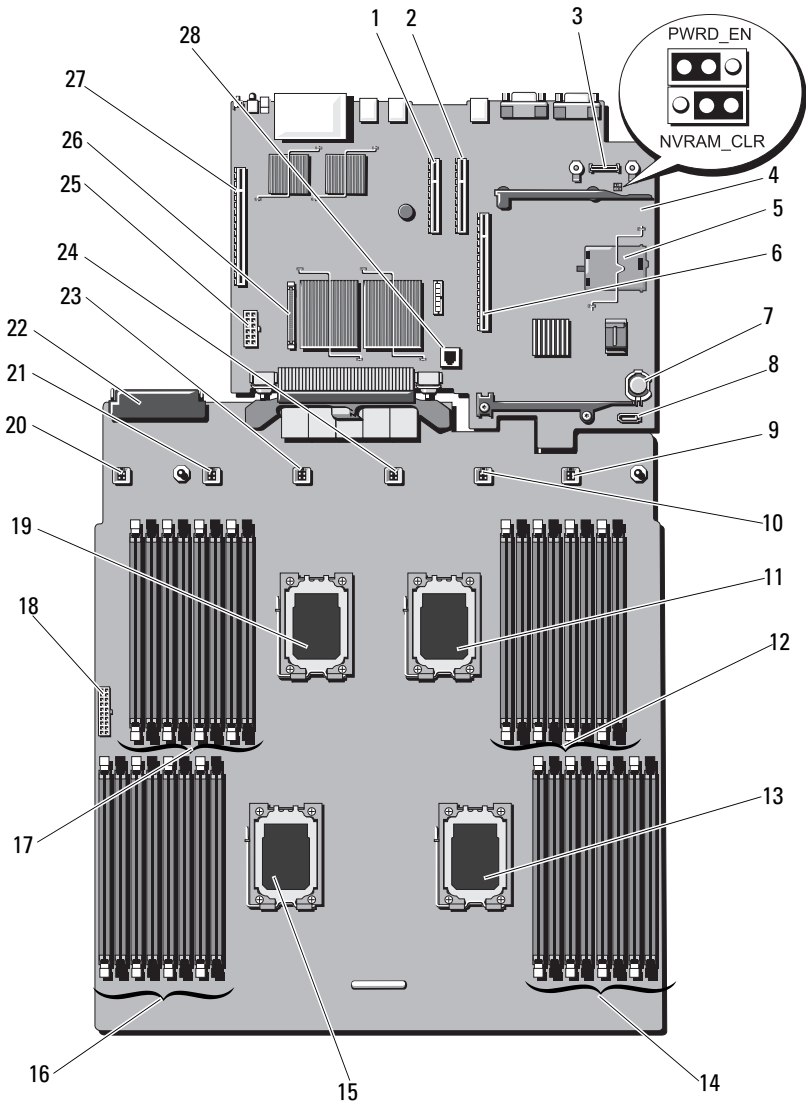

<b>Item</b>	<b>Connector</b>	<b>Description</b>
1	SLOT4_PCIE_G2_X8	slot 4 PCIe - x8 link expansion slot
2	SLOT3_PCIE_G2_X8	slot 3 PCIe - x8 link expansion slot
3	AMEA CONN	iDRAC6 Enterprise card connector
4	PWRD_EN	Password enable jumper
	NVRAM_CLR	NVRAM clear jumper
5	MASER CONN	iDRAC6 Express card connector
6	Center PCIE_G2_X8	Expansion-card riser 1 connector
7	BATTERY	Battery socket
8	SATA	SATA power connector
9	FAN6	System cooling fan 6 connector
10	FAN5	System cooling fan 5 connector
11	CPU1	Processor 1 socket
12	A1	Memory module slot A1 (white release lever)
	A5	Memory module slot A5
	A2	Memory module slot A2 (white release lever)
	A6	Memory module slot A6
	A3	Memory module slot A3 (white release lever)
	A7	Memory module slot A7
	A4	Memory module slot A4 (white release lever)
	A8	Memory module slot A8
13	CPU3	Processor 3 socket
14	C1	Memory module slot C1 (white release lever)
	C5	Memory module slot C5
	C2	Memory module slot C2 (white release lever)
	C6	Memory module slot C6
	C3	Memory module slot C3 (white release lever)
	C7	Memory module slot C7

<b>Item</b>	<b>Connector</b>	<b>Description</b>
	C4	Memory module slot C4 (white release lever)
	C8	Memory module slot C8
15	CPU4	Processor 4 socket
16	D1	Memory module slot D1 (white release lever)
	D5	Memory module slot D5
	D2	Memory module slot D2 (white release lever)
	D6	Memory module slot D6
	D3	Memory module slot D3 (white release lever)
	D7	Memory module slot D7
	D4	Memory module slot D4 (white release lever)
	D8	Memory module slot D8
17	B1	Memory module slot B1 (white release lever)
	B5	Memory module slot B5
	B2	Memory module slot B2 (white release lever)
	B6	Memory module slot B6
	B3	Memory module slot B3 (white release lever)
	B7	Memory module slot B7
	B4	Memory module slot B4 (white release lever)
	B8	Memory module slot B8
18	BP_PWR	Backplane power and front panel USB connector
19	CPU2	Processor 2 socket
20	FAN1	System cooling fan 1 connector
21	FAN2	System cooling fan 2 connector
22	PDB_CON	Power distribution board connector
23	FAN3	System cooling fan 3 connector
24	FAN4	System cooling fan 4 connector
25	PWR_CONN	Power connector



Item	Connector	Description
26	CTRL_PNL	Control panel interface connector
27	Left PCIE_G2_X16	Expansion-card riser 2 connector
28	ISCSI Key	ISCSI key connector (NIC hardware key)

## SAS Backplane Board Connectors

Figure 6-2. SAS Backplane Board Connectors

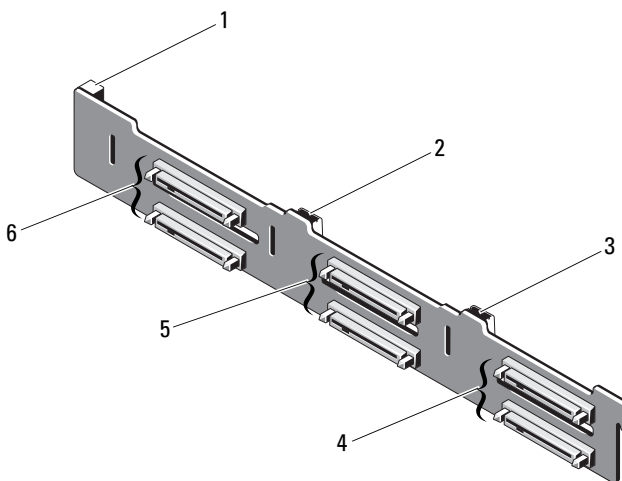

- |   |                               |   |                               |
|---|-------------------------------|---|-------------------------------|
| 1 | power connector               | 2 | SAS A connector               |
| 3 | SAS B connector               | 4 | hard-drive connectors 4 and 5 |
| 5 | hard-drive connectors 2 and 3 | 6 | hard-drive connectors 0 and 1 |

# Power Distribution Board Connectors

Figure 6-3. Power Distribution Board Connectors

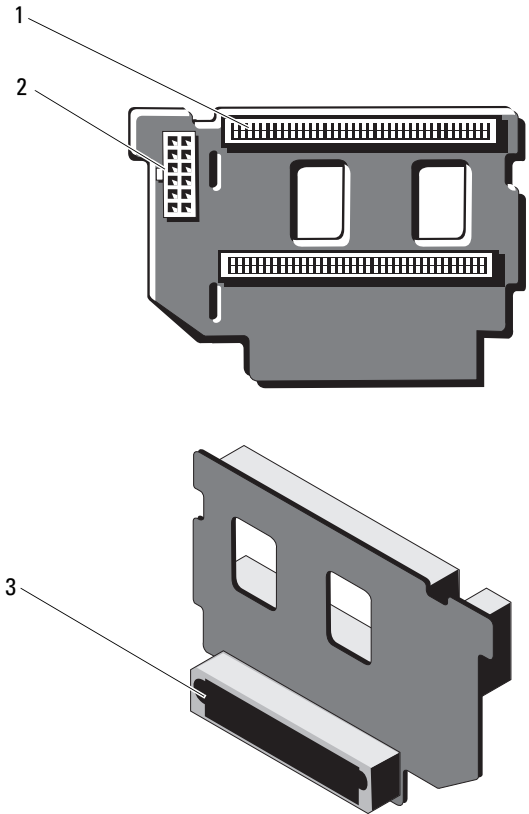

- 1 power supply connectors (2)
- 2 12-pin power cable connector
- 3 mixed signal connector

# Expansion-Card Riser-Board Components and PCIe Buses

Figure 6-4. PCIe Expansion-Card Riser 1 Components

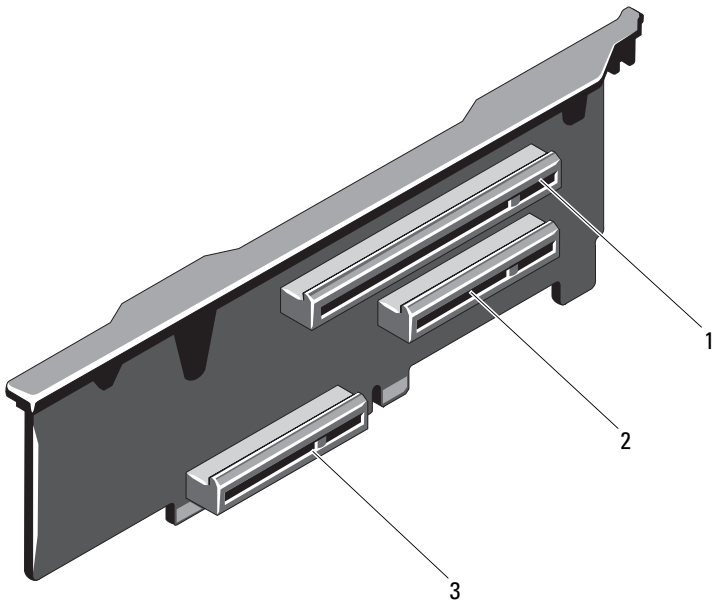

- 1 PCIe slot 1 connector
- 2 PCIe slot 2 connector
- 3 integrated storage controller card connector

**Figure 6-5. PCIe Expansion-Card Riser 2 Components**

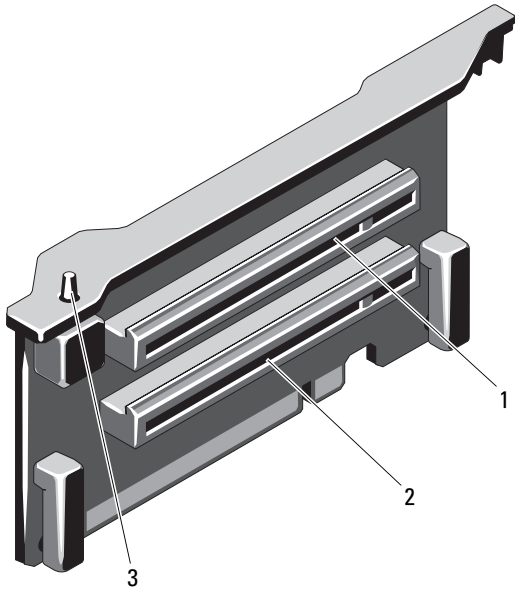

1 PCIe slot 5 connector

2 PCIe slot 6 connector

3 chassis intrusion switch

## Disabling a Forgotten Password

The system's software security features include a system password and a setup password, which are discussed in detail in "Using the System Setup Program and UEFI Boot Manager" on page 53. The password jumper enables these password features or disables them and clears any password(s) currently in use.



**CAUTION: See "Protecting Against Electrostatic Discharge" in the safety instructions that came with the system.**

- 1 Turn off the system, including any attached peripherals, and disconnect the system from the electrical outlet.
- 2 Open the system. See "Opening the System" on page 76.
- 3 Remove the jumper plug from the password jumper.  
See Figure 6-1 to locate the password jumper (labeled "PWRD\_EN") on the system board.
- 4 Close the system.
- 5 Reconnect your system and peripherals to their electrical outlets, and turn on the system.

The existing passwords are not disabled (erased) until the system boots with the password jumper plug removed. However, before you assign a new system and/or setup password, you must install the jumper plug.



**NOTE:** If you assign a new system and/or setup password with the jumper plug still removed, the system disables the new password(s) the next time it boots.

- 6 Turn off the system, including any attached peripherals, and disconnect the system from the electrical outlet.
- 7 Open the system. See "Closing the System" on page 77.
- 8 Install the jumper plug on the password jumper.
- 9 Close the system.
- 10 Reconnect your system and peripherals to their electrical outlets, and turn on the system.
- 11 Assign a new system and/or setup password.  
To assign a new password using the System Setup program, see "Assigning a System Password" on page 67.



# Getting Help

## Contacting Dell

For customers in the United States, call 800-WWW-DELL (800-999-33155).



**NOTE:** If you do not have an active Internet connection, you can find contact information on your purchase invoice, packing slip, bill, or Dell product catalog.

Dell provides several online and telephone-based support and service options. Availability varies by country and product, and some services may not be available in your area. To contact Dell for sales, technical support, or customer service issues:

- 1 Visit [support.dell.com](http://support.dell.com).
- 2 Verify your country or region in the **Choose A Country/Region** drop-down menu at the bottom of the page.
- 3 Click **Contact Us** on the left side of the page.
- 4 Select the appropriate service or support link based on your need.
- 5 Choose the method of contacting Dell that is convenient for you.





# Index

## B

- batteries
  - troubleshooting, 156
- battery
  - troubleshooting the RAID card
    - battery, 166
- battery (system)
  - replacing, 132
- blank
  - hard drive, 78
  - power supply, 87

## C

- cabling
  - optical drive, 83
- CD drive
  - troubleshooting, 164
- CD/DVD drive
  - See optical drive.
- chassis intrusion switch, 182
- connectors
  - USB, 12, 18
  - video, 12, 18
- contacting Dell, 185
- control panel assembly
  - features, 12
  - LCD panel features, 14

- cooling fans
  - troubleshooting, 158

## D

- damaged systems
  - troubleshooting, 155
- Dell
  - contacting, 185
- Dell PowerEdge Diagnostics
  - using, 171
- diagnostics
  - advanced testing options, 171
  - testing options, 171
  - using Dell PowerEdge Diagnostics, 171
- DIMMs
  - See memory modules (DIMMs).
- drive blank
  - installing, 79
  - removing, 78
- drive carrier
  - hard drive, 82

## E

- error messages, 54
- expansion card

- troubleshooting, 167
- expansion cards
  - installing, 109
  - removing, 111
  - SAS controller, 116
- expansion slots, 107

## F

- front bezel
  - installing, 75
  - removing, 75
- front panel assembly, 90
- front-panel features, 12

## G

- guidelines
  - connecting external devices, 20
  - expansion card installation, 107
  - memory installation, 93

## H

- hard drive
  - drive carrier, 82
  - installing, 81
  - removing, 80
  - troubleshooting, 165
- heat sink, 127
- hot-plug
  - hard drives, 78

## I

- iDRAC card
  - installing, 121
- iDRAC Configuration Utility, 71
- indicators
  - front-panel, 12
  - NIC, 20
  - power, 12, 21
- installing
  - expansion card, 109
  - front bezel, 75
  - hard drive blank, 79
  - hard drives, 81
  - iDRAC card, 121
  - memory modules, 98
  - optical drive, 83
  - power supply blank, 87
  - processor, 130
  - SAS backplane board, 136
  - SAS controller, 118
- Installing the Processor Board, 148

## K

- keyboards
  - troubleshooting, 152

## L

- LCD panel
  - features, 14
  - menus, 15

## **M**

- memory
  - troubleshooting, 159
- memory key connector (USB), 105
- memory modules (DIMMs)
  - configuring, 93
  - installing, 98
  - removing, 100
- messages
  - error messages, 54
  - status LCD, 22
  - system, 38
  - warning, 51
- microprocessor
  - See processor.
- microprocessors
  - troubleshooting, 168

## **N**

- NIC
  - indicators, 20
- NIC TOE, 106
- NICs
  - troubleshooting, 153

## **O**

- optical drive
  - installing, 83
- options

system setup, 55

## **P**

- password
  - disabling, 183
  - setup, 69
  - system, 67
- phone numbers, 185
- POST
  - accessing system features, 11
- power indicators, 12, 21
- power supplies
  - indicators, 21
  - removing, 85
  - replacing, 87
  - troubleshooting, 157
- power supply blank, 87
- processor
  - installing, 130
  - removing, 126
  - upgrades, 126

## **R**

- recommended tools, 73
- removing
  - expansion card, 111
  - front bezel, 75
  - hard drive blank, 78
  - hard drive from a drive carrier, 82
  - hard drives, 80

- memory modules, 100
- power supply, 85
- power supply blank, 87
- processor, 126
- SAS backplane board, 134
- SAS controller, 116
- system board, 144

Removing the Processor Board, 145

replacing

- power supply, 87
- system battery, 132

## **S**

safety, 151

SAS backplane board

- installing, 136
- removing, 134

SAS controller card

- installing, 118
- removing, 116

SAS controller daughter card

- troubleshooting, 166

SAS RAID controller daughter card

- troubleshooting, 166

SD card

- troubleshooting, 162-163

securing your system, 63, 68

service-only procedure

- system board, 144

setup password, 69

slots

- See expansion slots.

startup

- accessing system features, 11

support

- contacting Dell, 185

system board

- installing, 148
- removing, 144

system cooling

- troubleshooting, 157

system features

- accessing, 11

system messages, 38

system password, 67

system setup

- options, 55

system setup program

- boot settings, 59
- entering, 54
- integrated devices options, 60
- keystroke, 54
- memory settings, 57
- PCI IRQ assignments, 61
- power management options, 62
- processor settings, 58
- SATA settings, 59
- serial communications
  - options, 61
- system security options, 63

system setup screens

- main, 55
- system startup failure, 151

## **T**

- telephone numbers, 185
- TPM security, 63
- troubleshooting
  - battery, 156
  - CD drive, 164
  - cooling fans, 158
  - damaged system, 155
  - expansion card, 167
  - external connections, 151
  - hard drive, 165
  - internal USB key, 162-163
  - keyboard, 152
  - memory, 159
  - microprocessors, 168
  - NIC, 153
  - power supplies, 157
  - SAS RAID controller daughter card, 166
  - SD card, 162-163
  - system cooling, 157
  - system startup failure, 151
  - video, 152
  - wet system, 154

## **U**

- UEFI Boot Manager
  - entering, 64
  - main screen, 65

- System Utilities screen, 66
- UEFI Boot Settings screen, 65

- upgrades
  - processor, 126

## **USB**

- front-panel connectors, 12
- internal connector for memory key, 105

## **USB key**

- troubleshooting, 162-163

## **V**

### **video**

- front-panel connectors, 12
- troubleshooting, 152

## **W**

- warning messages, 51
- warranty, 51
- wet system
  - troubleshooting, 154



## Free Manuals Download Website

<http://myh66.com>

<http://usermanuals.us>

<http://www.somanuals.com>

<http://www.4manuals.cc>

<http://www.manual-lib.com>

<http://www.404manual.com>

<http://www.luxmanual.com>

<http://aubethermostatmanual.com>

Golf course search by state

<http://golfingnear.com>

Email search by domain

<http://emailbydomain.com>

Auto manuals search

<http://auto.somanuals.com>

TV manuals search

<http://tv.somanuals.com>