



Dell® PowerEdge® 4350 Systems

USER'S GUIDE

**Information in this document is subject to change without notice.
© 1998 Dell Computer Corporation. All rights reserved.**

Reproduction in any manner whatsoever without the written permission of Dell Computer Corporation is strictly forbidden.

Trademarks used in this text: *Dell*, the *DELL* logo, and *PowerEdge* are registered trademarks, *Dell OpenManage* is a trademark, and *DellWare* is a registered service mark of Dell Computer Corporation; *Intel* and *Pentium* are registered trademarks, and *MMX* and *Intel386* are trademarks of Intel Corporation; *Microsoft*, *Windows*, *MS-DOS*, and *Windows NT* are registered trademarks of Microsoft Corporation; *Novell* and *NetWare* are registered trademarks of Novell, Inc.; *ASPI* is a registered trademark of Adaptec, Inc.; *VESA* is a registered trademark and *VL-Bus* is a trademark of Video Electronics Standards Association.

Other trademarks and trade names may be used in this document to refer to either the entities claiming the marks and names or their products. Dell Computer Corporation disclaims any proprietary interest in trademarks and trade names other than its own.

October 1998 P/N 3502E



Safety Instructions

Use the following safety guidelines to help protect your computer system from potential damage and to ensure your own personal safety.



WARNING: The power supplies in this computer system produce high voltages and energy hazards, which can cause bodily harm. Only trained service technicians are authorized to remove the computer covers and access any of the components inside the computer.

WARNING

There is a danger of a new battery exploding if it is incorrectly installed. Replace the battery only with the same or equivalent type recommended by the manufacturer. Discard used batteries according to the manufacturer's instructions.



WARNING: This system may have more than one power supply cable. To reduce the risk of electrical shock, a trained service technician must disconnect all power supply cables before servicing the system.

When Using Your Computer System

As you use your computer system, observe the following safety guidelines:

- Be sure your monitor and attached peripherals are electrically rated to operate with the AC power available in your location.
- To help prevent electric shock, plug the computer and peripheral power cables into properly grounded power sources. These cables are equipped with three-prong plugs to help ensure proper grounding. Do not use adapter plugs or remove the grounding prong from a cable. If you must use an extension cable, use a three-wire cable with properly grounded plugs.
- To help protect your computer system from sudden, transient increases and decreases in electrical power, use a surge suppressor, line conditioner, or uninterruptible power supply (UPS).
- Be sure nothing rests on your computer system's cables and that the cables are not located where they can be stepped on or tripped over.

- Do not spill food or liquids on your computer.
- Do not push any objects into the openings of your computer. Doing so can cause fire or electric shock by shorting out interior components.
- Keep your computer away from radiators and heat sources. Also, do not block cooling vents. Avoid placing loose papers underneath your computer; do not place your computer in a closed-in wall unit or on a rug.

Ergonomic Computing Habits



WARNING: Improper or prolonged keyboard use may result in injury.

For comfort and efficiency, observe the following ergonomic guidelines when setting up and using your computer system:

- Position your system so that the monitor and keyboard are directly in front of you as you work. Special shelves are available (from Dell and other sources) to help you correctly position your keyboard.
- Set the monitor at a comfortable viewing distance (usually 510 to 610 millimeters [20 to 24 inches] from your eyes).
- Make sure the monitor screen is at eye level or slightly lower when you are sitting in front of the monitor.
- Adjust the tilt of the monitor, its contrast and brightness settings, and the lighting around you (such as overhead lights, desk lamps, and the curtains or blinds on nearby windows) to minimize reflections and glare on the monitor screen.
- Use a chair that provides good lower back support.
- Keep your forearms horizontal with your wrists in a neutral, comfortable position while using the keyboard or mouse.
- Always leave space to rest your hands while using the keyboard or mouse.
- Let your upper arms hang naturally at your sides.
- Sit erect, with your feet resting on the floor and your thighs level.
- When sitting, make sure the weight of your legs is on your feet and not on the front of your chair seat. Adjust your chair's height or use a footrest, if necessary, to maintain proper posture.
- Vary your work activities. Try to organize your work so that you do not have to type for extended periods of time. When you stop typing, try to do things that use both hands.

When Working With Your Computer



CAUTION: To help avoid possible damage to the system board, wait 5 seconds after turning off the system before disconnecting a peripheral device from the computer.

When you disconnect a cable from your system, pull on its connector or on its strain-relief loop, not on the cable itself. Some cables have a connector with locking tabs; if you are disconnecting this type of cable, press in on the locking tabs before disconnecting the cable. As you pull connectors apart, keep them evenly aligned to avoid bending any connector pins. Also, before you connect a cable, make sure both connectors are correctly oriented and aligned.

Protecting Against Electrostatic Discharge

Static electricity can harm delicate components inside your computer. To prevent static damage, discharge static electricity from your body before you touch any of your computer's electronic components, such as the microprocessor. You can do so by touching an unpainted metal surface on the computer chassis.

As you continue to work inside the computer, periodically touch an unpainted metal surface to remove any static charge your body may have accumulated.

You can also take the following steps to prevent damage from electrostatic discharge (ESD):

- When unpacking a static-sensitive component from its shipping carton, do not remove the component from the antistatic packing material until you are ready to install the component in your computer. Just before unwrapping the antistatic packaging, be sure to discharge static electricity from your body.
- When transporting a sensitive component, first place it in an antistatic container or packaging.
- Handle all sensitive components in a static-safe area. If possible, use antistatic floor pads and workbench pads.

The following caution may appear throughout this document to remind you of these precautions:



CAUTION: See “Protecting Against Electrostatic Discharge” in the safety instructions at the front of this guide.



Preface

About This Guide

This guide is intended for anyone who uses the Dell PowerEdge 4350 computer system. The guide can be used by both first-time and experienced computer users who want to learn about the features and operation of the systems or who want to upgrade their systems. The chapters and appendices are summarized as follows:

- Everyone should read Chapter 1, "Introduction," for an overview of the system features, a description of the controls and indicators on the front panel, and a general discussion of connecting external devices to the back panel of the system.
- Users who want to use the utilities, the diagnostics, or the online documentation, or who want to install drivers for their operating system, should read Chapter 2, "Using the Dell OpenManage Server Assistant CD."
- Everyone should read the first few sections of Chapter 3, "Installing and Configuring SCSI Drivers," to find out which small computer system interface (SCSI) device drivers (if any) are required for a particular system configuration. Users who need to install and configure particular SCSI device drivers should then read the appropriate section for their operating system.
- Everyone should read the first several sections of Chapter 4, "Using the System Setup Program," to become familiar with this important program. Only users who want to make configuration changes to their system or who want to use the password features need to read the rest of Chapter 4.
- Everyone should read Chapter 5, "Using the Resource Configuration Utility," whenever a Peripheral Component Interconnect (PCI) expansion card is added, removed, or repositioned in the computer, or when the settings for one of the built-in devices is changed.
- Appendix A, "Technical Specifications," summarizes the technical specifications of the PowerEdge 4350.
- Appendix B, "I/O Ports and Connectors," provides specific information about the ports and connectors on the back panel of the PowerEdge 4350.
- Appendix C, "Maintaining the System," describes preventive maintenance procedures that you should perform regularly to keep the system in top operating condition.

- Appendix D, “Regulatory Notices,” is for users who are interested in which regulatory agencies have tested and approved the Dell PowerEdge 4350 systems.
- Appendix E, “Warranty, Return Policy, and Year 2000 Statement of Compliance,” describes the warranty and return policy for Dell PowerEdge 4350 systems. It also provides information about year 2000 compliance of Dell-branded hardware products.
- The Glossary provides definitions of terms, acronyms, and abbreviations used in this guide.

Warranty and Return Policy Information

Dell Computer Corporation (“Dell”) manufactures its hardware products from parts and components that are new or equivalent to new in accordance with industry-standard practices. For information about the Dell warranty for your system, see Appendix E, “Warranty, Return Policy, and Year 2000 Statement of Compliance.”

Other Documents You May Need

In addition to this *User’s Guide*, the following documentation is included with your system:

- The *Installation and Troubleshooting Guide* provides instructions for installing system hardware and includes troubleshooting and diagnostic procedures for testing your computer system.
- The *HP OpenView Network Node Manager Special Edition x.x With Dell OpenManage HIP x.x User’s Guide* describes the alert messages issued by the server management software.

You may also have one or more of the following documents:

- Operating system documentation is included with the system if you ordered the operating system software from Dell. This documentation describes how to install (if necessary), configure, and use the operating system software.
- Documentation is included with any options you purchase separately from the system. This documentation includes information that you need to configure and install these options in your Dell computer.
- Technical information files—sometimes called “readme” files—may be installed on the hard-disk drive to provide last-minute updates about technical changes to the system or advanced technical reference material intended for experienced users or technicians.



*NOTE: Documentation updates are sometimes included with your system to describe changes to your system or software. Always read these updates **before** consulting any other documentation because the updates often contain the latest information.*

Notational Conventions

The following subsections list notational conventions used in this document.

Notes, Cautions, and Warnings

Throughout this guide, blocks of text may be accompanied by an icon and printed in bold type or in italic type. These blocks are notes, cautions, and warnings, and they are used as follows:



NOTE: A NOTE indicates important information that helps you make better use of your system.



CAUTION: A CAUTION indicates either potential damage to hardware or loss of data and tells you how to avoid the problem.



WARNING: A WARNING indicates the potential for bodily harm and tells you how to avoid the problem.

Some warnings may appear in alternate formats and may be unaccompanied by an icon. In such cases, the specific presentation of the warning is mandated by regulatory authority.

Typographical Conventions

The following list defines (where appropriate) and illustrates typographical conventions used as visual cues for specific elements of text throughout this document:

- *Interface components* are window titles, button and icon names, menu names and selections, and other options that appear on the monitor screen or display. They are presented in bold.
Example: Click **OK**.
- *Keycaps* are labels that appear on the keys on a keyboard. They are enclosed in angle brackets.
Example: <Enter>
- *Key combinations* are series of keys to be pressed simultaneously (unless otherwise indicated) to perform a single function.
Example: <Ctrl><Alt>
- *Commands* presented in lowercase bold are for reference purposes only and are not intended to be typed when referenced.
Example: "Use the **format** command to . . ."

In contrast, commands presented in the Courier New font are a part of an instruction and intended to be typed.

Example: "Type `format a:` to format the diskette in drive A."

- *Filenames* and *directory names* are presented in lowercase bold.
Example: **autoexec.bat** and **c:\windows**
- *Syntax lines* consist of a command and all its possible parameters. Commands are presented in lowercase bold; variable parameters (those for which you substitute a value) are presented in lowercase italics; constant parameters are presented in lowercase bold. The brackets indicate items that are optional.
Example: **del** [*drive:*] [*path*]*filename* [**/p**]
- *Command lines* consist of a command and may include one or more of the command's possible parameters. Command lines are presented in the Courier New font.
Example: `del c:\myfile.doc`
- *Screen text* is a message or text that you are instructed to type as part of a command (referred to as a *command line*). Screen text is presented in the Courier New font.
Example: The following message appears on your screen:

`No boot device available`
Example: "Type `md c:\dos`, and then press <Enter>."
- *Variables* are symbols for which you substitute a value. They are presented in italics.
Example: DIMM *x* (where *x* represents the DIMM socket designation)



Contents

Chapter 1	Introduction.	1-1
	System Features	1-1
	Supported Operating Systems	1-4
	Front Panel	1-4
	Connecting External Devices.	1-7
	Preventing Unauthorized Access Inside the System	1-7
	Getting Help	1-7
Chapter 2	Using the Dell OpenManage Server Assistant CD . . .	2-1
	Booting From the CD.	2-1
	Navigating the CD Menus.	2-1
	Using the CD	2-2
	Utility Partition	2-2
	Running System Diagnostics	2-4
	Video Drivers	2-4
	Installing Video Drivers for Supported Windows NT Server 4.0 Operating Systems.	2-5
	Asset Tag Utility	2-6
	Using the Asset Tag Utility.	2-6
	Assigning and Deleting an Asset Tag Number	2-6
Chapter 3	Installing and Configuring SCSI Drivers.	3-1
	Dell-Installed Windows NT Server 4.0 or IntranetWare 4.11.	3-1
	Customer-Installed Windows NT Server 4.0 or IntranetWare 4.11.	3-1
	The SCSISelect Utility	3-2
	Starting the SCSISelect Utility	3-2
	Using SCSISelect Menus	3-2
	Configure/View Host Adapter Settings	3-3

SCSI Disk Utilities	3-3
Exiting SCSISelect	3-3
SCSISelect Defaults.	3-3
SCSI Bus Interface Definitions.	3-5
Boot Device Options	3-6
SCSI Device/Configuration Settings.	3-6
Advanced Host Adapter Settings	3-7
Installation for Supported Windows NT Server Operating Systems.	3-9
Installation Overview	3-9
Installing SCSI Drivers During Windows NT Installation	3-10
Removing a Host Adapter	3-11
Swapping a Host Adapter	3-12
Troubleshooting for Windows NT	3-13
Installation for Novell IntranetWare 4.11	3-13
Installation Overview	3-14
Creating the IntranetWare 4.11 Driver Diskettes.	3-15
Preparing the Hard-Disk Drive for IntranetWare Installation	3-15
Installing SCSI Drivers During IntranetWare 4.11 Installation	3-16
Installing the Dell-Supplied Novell Patches and Support Pack 5	3-19
Dell-Provided IntranetWare 4.11.	3-20
IntranetWare 4.11 From Sources Other Than Dell.	3-20
Installing SMP Support	3-21
Using <code>startup.ncf</code> and <code>autoexec.ncf</code>	3-21
Using Drives Tested and Approved for IntranetWare	3-22
Setting Up a CD-ROM Drive With IntranetWare 4.11	3-23
Optimizing Performance	3-23
Troubleshooting for IntranetWare	3-23
Non-Host-Adapter-Specific Error Codes.	3-24
Host-Adapter-Specific Error Codes.	3-24

Chapter 4 Using the System Setup Program 4-1

Entering the System Setup Program	4-2
System Setup Screens	4-2
Using the System Setup Program.	4-3
System Setup Options	4-5
Time.	4-5
Date	4-5
Diskette Drive A and Diskette Drive B.	4-5
Reserved Memory	4-6
CPU Speed.	4-6
Num Lock.	4-6
Processor 1 and Processor 2	4-6

Fan Speed	4-6
System Alert.	4-7
Keyboard Errors	4-7
Boot Sequence	4-7
Diskette First.	4-7
Hard Disk Only	4-7
Scan Sequence.	4-8
System Password	4-8
Password Status	4-8
Setup Password	4-9
Mouse	4-9
Serial Port 1 and Serial Port 2.	4-9
Parallel Port	4-9
Parallel Mode	4-10
Diskette	4-10
Speaker	4-10
Primary SCSI and Secondary SCSI.	4-10
System Data.	4-10
Using the System Password Feature	4-11
Assigning a System Password.	4-11
Using Your System Password to Secure Your System	4-13
Deleting or Changing an Existing System Password	4-14
Using the Setup Password Feature.	4-14
Assigning a Setup Password	4-15
Operating With a Setup Password Enabled.	4-15
Deleting or Changing an Existing Setup Password	4-15
Disabling a Forgotten Password	4-16
Responding to Error Messages.	4-16

Chapter 5

Using the Resource Configuration Utility 5-1

Configuring ISA and PCI Expansion Cards	5-1
How to Run the RCU.	5-2
When to Run the RCU	5-2
Making Selections in the RCU	5-2
Using Online Instructions.	5-2
Starting the RCU	5-2
Main Menu	5-3
Learn About Configuring Your Computer.	5-3
Configure Computer	5-4
Step 1: Important Resource Configuration Information	5-4
Step 2: Add or Remove Boards.	5-4
Step 3: View or Edit Details	5-4

Step 4: Examine Switches or Print Report	5-6
Step 5: Save and Exit	5-6
Set Date	5-6
Set Time	5-6
Maintain Resource Configuration Diskette	5-6
Exit From This Utility	5-6
Advanced Menu	5-6
Lock/Unlock Boards	5-7
View Additional System Information Menu	5-7
Set Verification Mode Menu	5-7
Maintain SCI Files Menu	5-8
Resolving Resource Conflicts	5-8
Removing a Card that Conflicts With the Card You Just Installed.	5-9

Appendix A Technical Specifications A-1

Appendix B I/O Ports and Connectors B-1

Serial and Parallel Ports	B-1
Adding an Expansion Card Containing Serial or Parallel Ports	B-2
Serial Port Connectors	B-3
Parallel Port Connector	B-4
Keyboard and Mouse Connectors	B-5
Keyboard Connector	B-6
Mouse Connector	B-6
Video Connector	B-7
Server-Management Bus Connectors	B-9

Appendix C Maintaining the System. C-1

Data Preservation	C-1
Scheduling Backups	C-1
Backup Devices	C-1
Recovering Data	C-2
Cleaning System Components	C-2
Recommended Tools and Accessories	C-3
Cleaning the System, Monitor, and Keyboard Exteriors	C-3
Cleaning Drives	C-4
Environmental Factors	C-4
Temperature	C-4
Humidity	C-5
Altitude	C-5
Dust and Particles	C-5
Corrosion	C-6

ESD	C-6
Electromagnetic and Radio Frequency Interference	C-6
Magnetism	C-7
Shock and Vibration	C-7
Power Source Interruptions	C-8
Power Protection Devices	C-9
Surge Protectors	C-9
Line Conditioners	C-9
Uninterruptible Power Supplies	C-9

Appendix D Regulatory Notices D-1

FCC Notices (U.S. Only)	D-2
Class A	D-3
IC Notice (Canada Only)	D-3
CE Notice (European Union)	D-4
EN 55022 Compliance (Czech Republic Only)	D-4
VCCI Notice (Japan Only)	D-4
Class A ITE	D-5
Class B ITE	D-5
MOC Notice (South Korea Only)	D-6
Class A Device	D-6
Class B Device	D-6
Polish Center for Testing and Certification Notice	D-7
Wymagania Polskiego Centrum Badań i Certyfikacji	D-7
Pozostałe instrukcje bezpieczeństwa	D-7
NOM Information (Mexico Only)	D-8
Información para NOM (únicamente para México)	D-9
BCIQ Notice (Taiwan Only)	D-9

**Appendix E Warranty, Return Policy, and Year 2000
Statement of Compliance E-1**

Limited Three-Year Warranty (U.S. and Canada Only)	E-1
Coverage During Year One	E-1
Coverage During Years Two and Three	E-2
General Provisions	E-2
“Total Satisfaction” Return Policy (U.S. and Canada Only)	E-3
Year 2000 Statement of Compliance for Dell-Branded Hardware Products	E-4
Previous Products	E-4
Software	E-5
Additional Information	E-5

Glossary

Index

Figures

Figure 1-1.	Front Panel	1-4
Figure 1-2.	Status Indicators	1-5
Figure 1-3.	Hot-Pluggable Hard-Disk Drive Indicators	1-6
Figure 4-1.	System Setup Screens	4-4
Figure 5-1.	View or Edit Details Screen (Example)	5-5
Figure B-1.	I/O Ports and Connectors	B-2
Figure B-2.	Pin Numbers for the Serial Port Connectors	B-3
Figure B-3.	Pin Numbers for the Parallel Port Connector	B-4
Figure B-4.	Pin Numbers for the Keyboard Connector	B-6
Figure B-5.	Pin Numbers for the Mouse Connector	B-6
Figure B-6.	Pin Numbers for the Video Connector	B-7
Figure B-7.	Pin Numbers for the Server-Management Bus Connectors	B-9
Figure D-1.	VCCI Class A ITE Regulatory Mark	D-5
Figure D-2.	VCCI Class B ITE Regulatory Mark	D-5
Figure D-3.	MOC Class A Regulatory Mark	D-6
Figure D-4.	MOC Class B Regulatory Mark	D-7

Tables

Table 2-1.	Utility Partition Menu Options	2-3
Table 2-2.	Asset Tag Command-Line Options	2-7
Table 3-1.	SCSI Controller Defaults	3-4
Table 4-1.	System-Setup Navigation Keys	4-3
Table A-1.	Technical Specifications	A-1
Table B-1.	Pin Assignments for the Serial Port Connectors	B-4
Table B-2.	Pin Assignments for the Parallel Port Connector	B-5
Table B-3.	Pin Assignments for the Keyboard Connector	B-6
Table B-4.	Pin Assignments for the Mouse Connector	B-7
Table B-5.	Pin Assignments for the Video Connector	B-8
Table B-6.	Pin Assignments for the Server-Management Bus Connectors	B-9



CHAPTER 1

Introduction

The Dell® PowerEdge® 4350, which features Intel® Pentium® II processors, is a feature-rich, enterprise-class server that offers the highest performance, availability, scalability, manageability, and investment protection features in an industry-leading, rack-dense form factor. The PowerEdge 4350 provides a robust, reliable, rack-optimized platform on which large corporate customers can deploy their mission-critical applications.

This chapter describes the major hardware and software features of the computer system, provides information about the indicators and controls on the system's front panel, and discusses connecting external devices to the system.

System Features

The PowerEdge 4350 systems offer the following major features:

- One or two Intel Pentium II microprocessors with an internal operating frequency of 350, 400, or 450 megahertz (MHz) and an external bus speed of 100 MHz.
The Pentium II microprocessor includes MMX™ technology designed to handle complex multimedia and communications software. This microprocessor incorporates new instructions and data types as well as a technique called single instruction, multiple data (SIMD) that allows the microprocessor to process multiple data elements in parallel, thereby improving overall system performance.
- A secondary (L2) cache of 512 kilobytes (KB) of static random-access memory (SRAM) is included within the single-edge contact (SEC) cartridge that contains the microprocessor. Math coprocessor functionality is internal to the microprocessor.
- Support for symmetric multiprocessing (SMP) is available by installing a second Pentium II microprocessor. SMP greatly improves overall system performance by dividing microprocessor operations among the independent microprocessors. To take advantage of this feature, you must use an operating system that supports multiprocessing, such as Microsoft® Windows NT® 4.0 or Novell® NetWare® (also known as IntranetWare) 4.11 (and later versions).



NOTE: If you decide to upgrade your system by installing an additional microprocessor, you must order the microprocessor upgrade kit from Dell. Not all versions of the Pentium II microprocessor will work properly as an additional

microprocessor. The upgrade kit from Dell contains the correct version of the microprocessor for use as an additional microprocessor, as well as instructions for performing the upgrade. The second microprocessor must have the same internal operating frequency as the first.

- A minimum of 64 MB of system memory, upgradable to a maximum of 2 gigabytes (GB) by installing combinations of 64- or 128-MB unbuffered synchronous dynamic random-access memory (SDRAM) in dual in-line memory modules (DIMMs) or 256- or 512-MB registered SDRAM DIMMs in the 4 DIMM sockets on the system board. You cannot mix unbuffered SDRAM and registered SDRAM in the system.
- A basic input/output system (BIOS) that resides in flash memory on the Industry Standard Architecture (ISA) bus and can be upgraded if required.
- Up to three hot-pluggable, 1-inch, small computer system interface (SCSI) hard-disk drives.
- Two or three 275-watt (W) power supplies. Multiple power supplies require a power-supply paralleling board (PSPB) and are hot-pluggable from the PSPB.



NOTE: A minimum configuration of two power supplies is nonredundant. To ensure redundancy, you must use three power supplies.

- Four redundant system cooling fans housed in a single, hot-swappable module.

The system board includes the following built-in features:

- Six Peripheral Component Interconnect (PCI) and two ISA expansion-card connectors. PCI slots 1 through 4 are unshared slots; PCI slot 5 is shared with ISA slot 5 and PCI slot 6 is shared with ISA slot 6.
- An advanced graphics port (AGP) video subsystem based on the ATI 3D Rage Pro super video graphics array (SVGA) video controller. This video subsystem contains 2 MB of synchronous graphics random-access memory (SGRAM) video memory (nonupgradeable). Maximum resolutions are 1280 x 1024 with 256 colors, noninterlaced. The 1024 x 768 resolution provides 65,536 colors, noninterlaced, and the 800 x 600 and 640 x 480 resolutions provide 16.7 million colors for true color graphics.
- A National Semiconductor PC87309 super input/output (I/O) controller that controls the bidirectional parallel port, two serial ports, and the diskette drive in the externally accessible front bay.

The parallel port can be set to operate in the following modes via the **Parallel Mode** option in the System Setup program: output-only (AT-compatible) or bidirectional (Personal System/2 [PS/2]-compatible).

- One Adaptec AIC-7890 Ultra2/low voltage differential (LVD) SCSI host adapter that supports up to three, 1-inch, internal SCSI hard-disk drives via a SCSI backplane board and SCSI hard-disk drive carriers. The SCSI backplane automatically

configures SCSI ID numbers and SCSI termination on individual hard-disk drives, greatly simplifying drive installation.

A 1 x 3 SCSI backplane board supports hot-pluggable SCSI hard-disk drive installation and removal when used in conjunction with the PowerEdge Expandable RAID Controller 2 or the PowerEdge Expandable RAID Controller 2/SC product.

- An Adaptec AIC-7860 Ultra/Narrow SCSI-3 host adapter that supports the CD-ROM drive.
- Server management circuitry that monitors operation of the system fans as well as critical system voltages and temperatures. The server management circuitry works in conjunction with the HP OpenView Network Node Manager Special Edition (NNM SE) and the Dell OpenManage™ Hardware Instrumentation Package (HIP) software package.
- System board support for the Dell OpenManage Remote Assistant when the optional Dell Remote Assistant Card version 2.0 (DRAC 2) is installed, which provides additional local and remote server management.
- A PS/2-style keyboard port and a PS/2-compatible mouse port.

Standard PowerEdge 4350 systems include a 3.5-inch diskette drive in an externally accessible bay, a SCSI CD-ROM drive in an externally accessible bay, and a SCSI hard-disk drive in slot 0.

The following software is included with your Dell system:

- Video drivers for displaying many popular applications in high-resolution modes. For more information on these drivers, see Chapter 2, "Using the Dell OpenManage Server Assistant CD."
- SCSI device drivers that allow your operating system to communicate with devices attached to the built-in SCSI subsystem. For more information on these drivers, see Chapter 3, "Installing and Configuring SCSI Drivers."
- HP OpenView software, including OpenView NNM SE with Dell OpenManage HIP, a standards-based management solution that provides concise and in-depth views of networked systems, devices, and connections through an intuitive graphical interface.
- The System Setup program for quickly viewing and changing the system configuration information for your system. For more information on this program, see Chapter 4, "Using the System Setup Program."
- The Resource Configuration Utility (RCU), which automatically configures installed ISA and PCI expansion cards. For more information, see Chapter 5, "Using the Resource Configuration Utility."
- Enhanced security features available through the System Setup program or the RCU, including a user password and a supervisor password.
- Diagnostics for evaluating your system's components and devices. For information on using the system diagnostics, see Chapter 2, "Using the Dell OpenManage Server Assistant CD" in this *User's Guide* or see Chapter 5, "Running the Dell Diagnostics," in your *Installation and Troubleshooting Guide*.

Supported Operating Systems

Dell supports the following network operating systems for use on PowerEdge 4350 systems:

- Microsoft Windows NT Server 4.0
- Microsoft Windows NT Server, Enterprise Edition
- Microsoft Windows NT Server 4.0, Terminal Server Edition
- Novell NetWare (also known as IntranetWare) 4.11

Front Panel

Figure 1-1 shows the following indicators on the system's front panel:

- The *hard-disk drive status indicator* is a steady green when the hard-disk drive is functioning properly, but blinks amber when a hard-disk drive failure is detected.
- The *fan/temperature status indicator* is a steady green when the fan status and system temperature are within bounds, but blinks amber when a fan failure is detected or temperature is out of bounds.
- The *power supply output status indicator* is a steady green when the electrical current output of the power supply is normal, but blinks amber if the power supply output ceases.

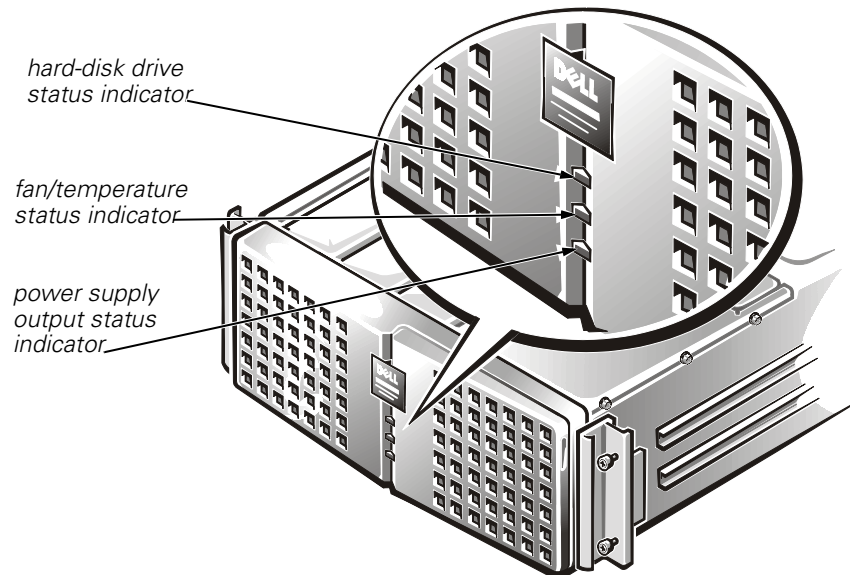

Figure 1-1. Front Panel

Figure 1-2 shows the following controls and indicators located behind the external drive door on the system's front panel:

- The *power button* controls the output power delivered to the system board from the power supply.
- The green *power indicator* in the center of the power button lights up when the power supply is turned on and the system is receiving direct current (DC) power.

NOTE: The power button is recessed into the system's front panel to prevent accidental turnoff and subsequent loss of valuable data.

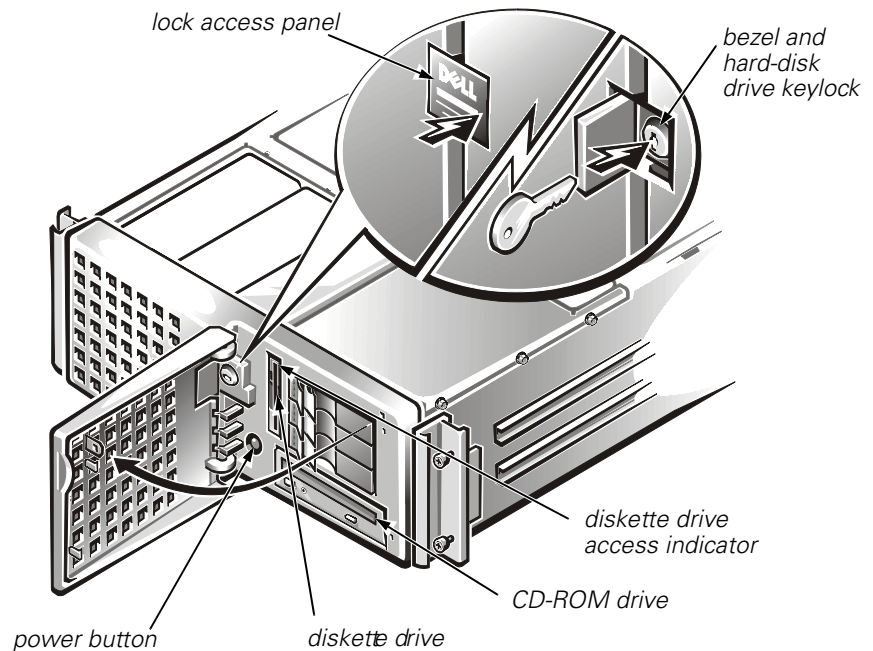

Figure 1-2. Status Indicators

Figure 1-3 shows the three indicator lights on each of the SCSI hard-disk drive carriers. These indicator lights provide the following information:

- The green *hard-disk drive online indicator* lights up when the hard-disk drive is receiving power.
- The green *hard-disk drive activity indicator* lights up when data is being transferred to or from the hard-disk drive.
- The amber *hard-disk drive failure indicator* blinks if a hard-disk drive failure is detected.

See the *Dell PowerEdge 4350 Installation and Troubleshooting Guide* for more information.

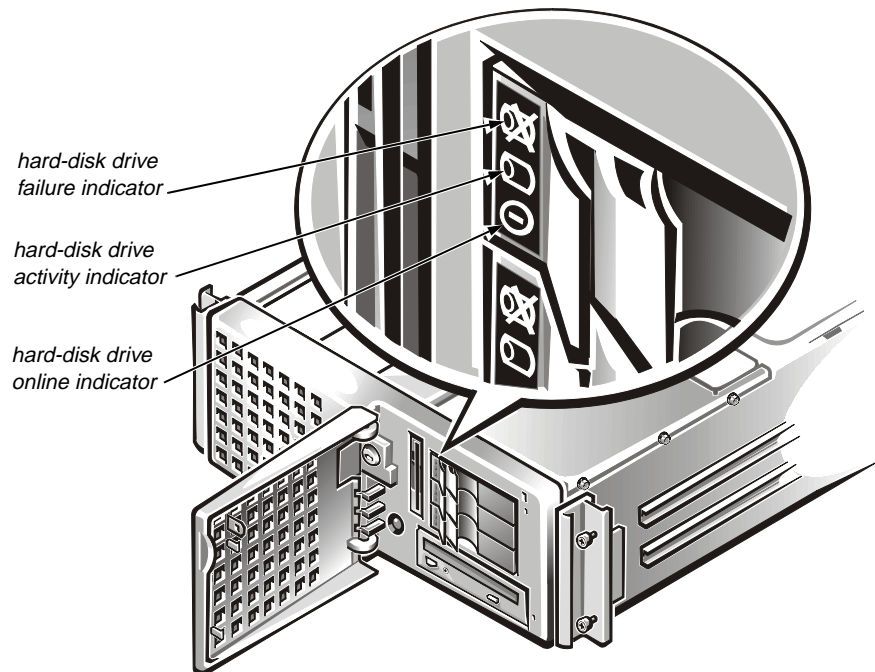

Figure 1-3. Hot-Pluggable Hard-Disk Drive Indicators

Connecting External Devices

You can connect various external devices, such as a mouse and printer, to the I/O ports and connectors on the system's back panel. The system BIOS detects the presence of external devices when you boot or reboot your system. When connecting external devices to your system, follow these guidelines:

- Check the documentation that accompanied the device for specific installation and configuration instructions.

For example, most devices must be connected to a particular I/O port or connector to operate properly. Also, external devices like a mouse or printer usually require you to load software files called *device drivers* into memory before they will work. These software drivers help the system recognize an external device and direct its operation. Device drivers of this type are normally included with your operating system software.

- Always attach external devices *while your system is turned off*. Then turn on any external devices *before* turning on the system unless the documentation for the device specifies otherwise. (If the system does not seem to recognize the device, try turning on the system before turning on the device.)

For information about enabling, disabling, or configuring I/O ports and connectors, see Chapter 4, "Using the System Setup Program," or Chapter 5, "Using the Resource Configuration Utility." For detailed descriptions and illustrations of each port and connector on the I/O panel, see Appendix B, "I/O Ports and Connectors."

Preventing Unauthorized Access Inside the System

A keylock behind the lock access panel on the front bezel prevents unauthorized access to the hot-pluggable hard-disk drives, CD-ROM drive, diskette drive, and the power switch, all of which are behind the bezel. A second lock on top of the unit prevents the top cover from being opened and the fans from being removed.

The PowerEdge 4350 system also includes a system intrusion switch that signals appropriate server management software if the top cover is opened.

Getting Help

If at any time you don't understand a procedure described in this guide, or if your system does not perform as expected, Dell provides a number of tools to help you. For more information on these help tools, see Chapter 12, "Getting Help," in your *Installation and Troubleshooting Guide*.



CHAPTER 2

Using the Dell OpenManage Server Assistant CD

This chapter describes the bootable *Dell OpenManage Server Assistant* CD and the system management tasks you can perform with the CD to configure and maintain your system. This chapter also describes the bootable utility partition installed on your system that provides many of the same functions and utilities as the *Dell OpenManage Server Assistant* CD.

Booting From the CD

The system must be running to insert the *Dell OpenManage Server Assistant* CD. To boot from the CD, insert it into the PowerEdge 4350 system's CD-ROM drive and press <Ctrl><Alt>. When the system boots, the CD main menu appears.

If the CD does not boot, check the following settings:

- In the System Setup program, the **Secondary SCSI** option must be set to **On** and the **Boot Sequence** option must be set to **Diskette First** (both of these settings are the defaults for their respective categories). See Chapter 4, "Using the System Setup Program," for more information.
- In the SCSI*Select* utility, the **BIOS Support For Bootable CD-ROM** option must be set to **Enabled**. See Chapter 3, "Installing and Configuring SCSI Drivers," for more information.

Navigating the CD Menus

Selections can be made from the CD menus using either a keyboard or a mouse. Associated help information is displayed in the help box at the bottom of the screen in the currently selected language (specified via a menu option).

Click **Back** to return to the previous menu. Click **Exit** (or press <Alt><x>) to exit the program. Exiting the program causes the system to reboot to the standard operating-system boot partition.

Using the CD

The *Dell OpenManage Server Assistant* CD provides important system utilities and documentation that you need to configure and maintain your system. The CD has an easy-to-use graphical user interface that enables you to quickly navigate to any data on the CD that you need. In addition, you are given a choice of several languages in which to view and use the CD interface.

The *Dell OpenManage Server Assistant* CD makes system setup and configuration as convenient as possible with clear, on-screen instructions and a number of automated configuration utilities. In addition to the setup utilities, the CD allows you to create blank formatted diskettes as well as diskettes of system utilities and operating system-specific drivers. You can also use the CD to re-create the utility partition on the hard-disk drive of your system if the existing utility partition ever becomes unusable or gets deleted from your system.

You can access the online system documents, as well as other information, on any desktop or server system that has a browser such as Microsoft Internet Explorer or Netscape Navigator. When you put the CD in a system running the Microsoft Windows® 95 operating system or Microsoft Windows NT, the system automatically starts the browser software and displays the documentation welcome page. The documents can either be viewed online or printed on a printer for hardcopy viewing. Also, if you have access to the Internet, the CD contains several useful and informative links to external Internet Web sites to provide you with up-to-date information and downloadable system files.

Utility Partition

The utility partition is a bootable partition on the hard-disk drive that provides some of the functions available on the *Dell OpenManage Server Assistant* CD. Most of the applications found on the CD are contained in the utility partition, occupying approximately 10 megabytes (MB) of space on the system's hard-disk drive. When implemented, the partition boots and provides an executable environment for the partition's utilities. When the partition is not implemented, it is designated as a non-MS-DOS® partition.



NOTE: The utility partition provides only limited MS-DOS functionality and cannot be used as a general-purpose MS-DOS partition.

Dell has installed the utility partition on your hard-disk drive; however, reinstalling the utility partition and/or its contents may be necessary if the version installed by Dell becomes damaged or is removed from the hard-disk drive. You can reinstall the utility partition and/or its contents using the *Dell OpenManage Server Assistant* CD.

To start the utility partition, press the <F10> key during power-on self-test (POST).

Like the *Dell OpenManage Server Assistant* CD, the utility partition provides a menu-driven interface from which you invoke the partition's utilities. Selections can be made

using either a keyboard or a mouse. Menu options and the associated help are displayed in the currently selected language (specified via a menu option).

As you move your cursor over an option in a menu, information about that option is displayed at the bottom of the screen.

Click **Back** to return to the previous menu. Click **Exit** (or press <Alt><x>) to exit the utility partition. Exiting the utility causes the system to reboot to the standard operating-system boot partition.

Table 2-1 provides a sample list and explanation of the options on the utility partition menu even when the *Dell OpenManage Server Assistant* CD is not in the CD-ROM drive. The options displayed on your system may vary depending on the configuration.



*NOTE: Although most options are available from both the Dell OpenManage Server Assistant CD and the utility partition, some options, such as accessing online documentation, are available only from the CD. The **Run System Diagnostics** option is only available from the utility partition.*

Table 2-1. Utility Partition Menu Options

Option	Description
Choose a Language:	
Deutsch, English, Español, Français	Allows the user to select the language in which to display menus and messages.
Configure the System:	
Run Resource Configuration Utility	Runs the Resource Configuration Utility (RCU).
Configure RAID Subsystem	Runs the Dell PowerEdge Expandable RAID Controller configuration utility if the controller card is present on your system.
Run System Utilities:	
Run System Diagnostics	Runs the system hardware diagnostics.
Upgrade Utility Partition	Allows the user to upgrade the utility partition (for example, adding, removing, or changing features installed on the partition).
Create Diskettes:	
Create Blank Formatted Diskette	Creates a blank, formatted diskette.

NOTE: For the full name of an abbreviation or acronym used in this table, see the Glossary.

Table 2-1. Utility Partition Menu Options (continued)

Option	Description
Create Utility Diskettes:	
Create RAID Configuration Utility Diskette	Creates a bootable diskette for running the Dell PowerEdge Expandable RAID Controller configuration utility (if the controller card is present on your system). The RAID configuration utility provides an alternative method for configuring the card.
Create Diagnostics Diskette	Creates a bootable diskette from which the hardware diagnostics can be run.
Create System utility Diskette	Creates a bootable diskette from which utilities, such as the Asset Tag utility, can be run.

NOTE: For the full name of an abbreviation or acronym used in this table, see the Glossary.



NOTE: The options displayed on your system are dependent on your system configuration and may not include all of those listed here.

Running System Diagnostics

The system diagnostics can be run from the utility partition or from a separate *Dell Diagnostics Diskette* provided with your system (the *Dell Diagnostics Diskette* has the latest diagnostics tests). From the **Utility Partition** menu, select **Run System Utilities** and then select **Run System Diagnostics**.

Before running the diagnostics, you should make a blank diskette and insert it in the diskette drive so the diagnostics programs can record critical messages and information as necessary. Use the **Create Blank Formatted Diskette** option to create a formatted diskette. The system hardware diagnostics are described in Chapter 5, "Running the Dell Diagnostics," of the *Installation and Troubleshooting Guide*.

Video Drivers



NOTES: The ATI video for the Microsoft Windows NT Server 4.0 operating system must be set up with a resolution of 640 x 480 at installation.

Windows NT Server 4.0 Service Pack 3 must be installed to use the updated drivers for ATI video.

You need to install the video drivers for the operating system you install on your PowerEdge 4350 system, unless they were installed by Dell. Use the following procedure to install the video drivers for Windows NT Server 4.0. The Novell NetWare operating system provides a textual interface and does not require video drivers.

Installing Video Drivers for Supported Windows NT Server 4.0 Operating Systems

This subsection provides information about installing video drivers for supported operating systems. For a list of the operating systems supported, see "Supported Operating Systems" in Chapter 1.



NOTE: Video drivers must be reinstalled after every installation of Windows NT 4.0 Service Pack 3.

Select the **Create Diskettes** option from the **Dell OpenManage Server Assistant** main menu, and create a diskette of software drivers for Windows NT 4.0 to keep as a backup. After you make the diskette of the drivers, use the following procedure to install the video drivers:

1. Start Windows NT.
2. Log in as the administrator or as a user with administrative privileges.

For information on system administration, see the reference documentation for Windows NT.

3. Click the **Start** button, point to **Settings**, and click **Control Panel**.
4. Double-click the **Display** icon.

The **Display Settings** window appears.

5. Select the **Settings** tab.
6. Click **Display Type**, and then click **Change** in the **Adapter** box.

A list of available video drivers is displayed.

7. Click **Have Disk**.
8. Insert the *ATI Installation Disk* into the diskette drive; then click **OK** in the **Install From Disk** window.

9. Make sure that **ATI Technologies Inc. 3D Rage Pro** (the default) is selected in the video driver list, and click **Install**.

The **Installing Drivers** dialog box appears.

10. Click **Yes** to proceed.

After the files are copied from the diskette, Windows NT prompts you to restart your system. Click **OK** and close all open windows.

11. Remove the *ATI Installation Disk* from the diskette drive, and restart Windows NT.

When you restart Windows NT, you can change the display resolution and color depth.

12. Open the **Program Manager**, access the **Control Panel**, and select the **Display** icon.

The **Display Settings** window appears.

13. Select the desired resolution, number of colors, and refresh rate.

Asset Tag Utility

The Asset Tag utility allows you to enter an asset tag number for your system. The default System Setup screen (see Figure 4-1) does not show the asset tag number unless you enter one using this utility.



NOTE: The Asset Tag utility works only on systems running MS-DOS.

Using the Asset Tag Utility

Use the following procedure to create a system utility diskette and boot the system:

1. If you have not already done so, create a bootable system utility diskette from the CD.
2. Insert the diskette into drive A, and reboot the system.



NOTE: The system utility diskette contains CD-ROM drivers that provide access to the CD-ROM drive when you boot from the diskette.

After you boot the system with the system utility diskette, you can use the Asset Tag utility to enter an asset tag number that you or your organization assign to the system. You can also use the Asset Tag utility to reenter the system's service tag number if that becomes necessary.

You can view the asset tag number using the System Setup program as described in Chapter 4, "Using the System Setup Program."

Assigning and Deleting an Asset Tag Number

An asset tag number can have up to ten characters; any combination of characters, excluding spaces, is valid. To assign or change an asset tag number, type `asset` and a space followed by the new number; then press <Enter>. For example, type the following command line and press <Enter>:

```
asset 1234567890
```

When prompted to verify the asset tag number, type `y` and press <Enter>. The system then displays the new or modified asset tag number and the service tag number.

To delete the asset tag number without assigning a new one, type `asset /d` and press <Enter>.

Table 2-2 lists the command-line options you can use with the Asset Tag utility. To use one of these options, type `asset` and a space followed by the option.

Table 2-2. Asset Tag Command-Line Options

Asset Tag Option	Description
/d	Deletes the asset tag number
/?	Displays the Asset Tag utility help screen



CHAPTER 3

Installing and Configuring SCSI Drivers

This chapter describes how to install and configure the Dell small computer system interface (SCSI) device drivers included with your Dell PowerEdge 4350 computer system. These device drivers are designed to work with the following host adapters:

- Embedded Adaptec AIC-7890 Ultra2/low voltage differential (LVD) SCSI-3 host adapter
- Embedded Adaptec AIC-7860 Ultra/Narrow SCSI-3 host adapter
- Optional AHA-2940U2W SCSI host adapter



NOTE: The term "host adapter" is used throughout this chapter to refer to the embedded AIC-7890 and AIC-7860 SCSI controllers or the optional AHA-2940U2W SCSI controller card.

Dell-Installed Windows NT Server 4.0 or IntranetWare 4.11

If Windows NT or IntranetWare was factory-installed by Dell, all of the SCSI drivers required by the PowerEdge 4350 system are preinstalled. You do not need to use the procedures in this chapter unless you need to reinstall the drivers at a later date. For a list of the operating systems supported, see "Supported Operating Systems" in Chapter 1.

Customer-Installed Windows NT Server 4.0 or IntranetWare 4.11

SCSI drivers are provided for the following operating systems:

- Microsoft Windows NT Server 4.0 and Windows NT Server, Enterprise Edition 4.0
- Novell IntranetWare (also called NetWare 4.11)

Refer to the *Dell OpenManage Server Assistant* CD to create a diskette of drivers for your operating system. For instructions on configuring the SCSI device drivers, see the appropriate sections in this chapter.

The AIC-7890 host adapter supports up to three 1-inch internal SCSI hard-disk drives via a standard SCSI backplane board. The AIC-7860 host adapter supports the CD-ROM drive.

The AIC-7890 and AIC-7860 host adapters and the optional AHA-2940U2W host adapter are all part of the Adaptec 78xx series of SCSI controllers, and all use the 78xx series of SCSI device drivers provided by Dell. The Adaptec SCSI basic input/output system (BIOS), which is stored in your computer system's flash memory or on the AHA-2940U2W SCSI controller card, links these SCSI device drivers to the AIC-7890 and AIC-7860 SCSI controller chips or the optional AHA-2940U2W SCSI controller card.

If you are using an optional Dell PowerEdge Expandable RAID Controller, the corresponding SCSI device drivers are installed at the same time as the SCSI device drivers for the AIC-7890, AIC-7860, and AHA-2940U2W host adapters. You can also refer to your RAID controller documentation for information on installing your SCSI device drivers.

For instructions on installing SCSI hardware devices such as hard-disk drives, external tape drives, or CD-ROM drives, trained service technicians should see Chapter 9, "Installing the Diskette and CD-ROM Drives," and Chapter 10, "Installing Hard-Disk Drives," in the *Installation and Troubleshooting Guide*. After the SCSI devices are installed, you need to install and configure one or more SCSI device drivers so that your SCSI devices can communicate with your operating system.

The SCSISelect Utility

The BIOS for the built-in AIC-7890 and AIC-7860 SCSI controllers includes the menu-driven *SCSISelect* configuration utility, which allows you to change SCSI controller settings without opening the computer. *SCSISelect* also contains SCSI disk utilities that let you low-level format or verify the disk media of your SCSI hard-disk drives.

Starting the SCSISelect Utility

You can start the *SCSISelect* utility by pressing <Ctrl><a> when the following prompt appears briefly during start-up:

```
Press <CTRL><A> for SCSISelect (TM) Utility.
```

The first menu displays two options:

- **Configure/View Host Adapter Settings**
- **SCSI Disk Utilities**

Using SCSISelect Menus

SCSISelect uses menus to list options you can select. To select an option, use the up- and down-arrow keys to move the cursor to the option; then press <Enter>.

In some cases, selecting an option displays another menu. You can return to the previous menu at any time by pressing <Esc>. To restore the original SCSI*Select* defaults, press <F6>.

Configure/View Host Adapter Settings

Select **Configure/View Host Adapter Settings** to display the current settings for the SCSI bus interface, boot device options, SCSI device/configuration, and advanced host adapter. Before changing the settings, review the list of settings in Table 3-1 and the descriptions of the settings in the subsections that follow Table 3-1.

SCSI Disk Utilities

To access the SCSI disk utilities, select **SCSI Disk Utilities** from the menu that appears when you start SCSI*Select*. When the option is selected, SCSI*Select* immediately scans the SCSI bus (to determine what devices are installed) and displays a list of all SCSI IDs and the device assigned to each ID.

When you select a specific ID and device, a small menu displaying the **Format Disk** and **Verify Disk Media** options appears.



CAUTION: The Format Disk option destroys all data on the hard-disk drive.

- **Format Disk** — This option runs a utility that allows you to perform a low-level format on a hard-disk drive. Most SCSI disk drives are formatted at the factory and do not need to be formatted again. The Adaptec Format Disk utility is compatible with the vast majority of SCSI hard-disk drives.
- **Verify Disk Media** — This option runs a utility that allows you to scan the hard-disk drive for defects. If the utility finds bad blocks, it prompts you to reassign them; if you select **Yes**, those blocks are no longer used. You can press <Esc> at any time to exit the utility.

Exiting SCSISelect

To exit SCSI*Select*, press <Esc> until a message prompts you to exit. (If you changed any 78xx series host adapter settings, you are prompted to save the changes before you exit.) At the prompt, select **Yes** to exit and then press any key to reboot the computer. Any changes you made in SCSI*Select* take effect after the computer boots. (You can select **No** at the prompt if you are not ready to exit SCSI*Select*.)

SCSISelect Defaults

The defaults for the optional Adaptec AHA-2940U2W SCSI controller and the built-in AIC-7890 and AIC-7860 SCSI controllers are shown in Table 3-1. These defaults are appropriate for most Peripheral Component Interconnect (PCI) systems. Run SCSI*Select* only if you need to change any of the defaults.



NOTE: The SCSISelect Utility must be run for both the AIC-7890 and the AIC-7860 SCSI controllers if you need to change the configuration settings.

To change any of the defaults, see “Configure/View Host Adapter Settings” found earlier in this chapter. To format or verify a disk, see “SCSI Disk Utilities” found earlier in this chapter.

Table 3-1. SCSI Controller Defaults

Option	Default for AIC-7860 Host Adapter	Default for AIC-7890 and 2940U2W Host Adapters
SCSI Bus Interface Definitions:		
Host Adapter SCSI ID	7	7
SCSI Parity Checking	Enabled	Enabled
Host Adapter SCSI Termination	Enabled	Enabled
Boot Device Options:		
Boot Target ID	0	0
Boot LUN Number	0	0
SCSI Device/Configuration Settings:		
Initiate Sync Negotiation	Yes	Yes
Maximum Sync Transfer Rate (MB/sec)	20	80
Enable Disconnection	Yes	Yes
Initiate Wide Negotiation	N/A	Yes
Send Start Unit	Yes	Yes
BIOS Multiple LUN Support	No	No
Include in BIOS Scan	Yes	Yes

NOTE: For the full name of an abbreviation or acronym used in this table, see the Glossary

Table 3-1. SCSI Controller Defaults (continued)

Option	Default for AIC-7860 Host Adapter	Default for AIC-7890 and 2940U2W Host Adapters
Advanced Host Adapter:		
Reset SCSI Bus at IC Initialization	Enabled	Enabled
Extended BIOS Translation For DOS Drives > 1 GB	Enabled	Enabled
Host Adapter BIOS	Enabled	Enabled
Support Removable Disks Under BIOS As Fixed Disks	Boot Only	Boot Only
Display <Ctrl><a> Message During BIOS Initialization	Enabled	Enabled
BIOS Support For Bootable CD-ROM	Enabled	Enabled
BIOS Support For Int13 Extensions	Enabled	Enabled

NOTE: For the full name of an abbreviation or acronym used in this table, see the Glossary

SCSI Bus Interface Definitions

The basic host adapter settings are the *SCSISelect* settings most likely to require modification:

- **Host Adapter SCSI ID** — This option sets the host adapter's SCSI ID. The default setting is **7**, which allows the host adapter to support narrow SCSI devices in addition to wide SCSI devices. Dell recommends that you leave the host adapter set to SCSI ID 7.
- **SCSI Parity Checking** — This option determines whether the host adapter verifies the accuracy of data transfer on the SCSI bus. Most SCSI devices support SCSI parity, so the default is **Enabled**. You should disable **SCSI Parity Checking** if any SCSI device connected to the host adapter does not support SCSI parity. If you are unsure if a device supports SCSI parity, consult the documentation for the device.
- **Host Adapter SCSI Termination** — This option sets termination on the host adapter. The default for the Adaptec AIC-7860 host adapter is **Enabled**; the default for the AIC-7890 and 2940U2W host adapters is **Enabled**. Dell recommends that you leave this option set to the default.

Boot Device Options

Boot Device Options allows you to specify the device from which to boot your system:

- **Boot Target ID** — This option specifies the SCSI ID of the device from which you boot your system. SCSI IDs are set for the hard-disk drive according to the drive's location on the backplane board for the SCSI ID of each drive location. The default for Boot Target ID is **0**.
- **Boot LUN Number** — If your boot device has multiple logical unit numbers (LUNs) and **BIOS Multiple LUN Support** is **Yes** (the default is **No**), see "Advanced Host Adapter Settings" found later in this section. This option allows you to specify a particular LUN from which to boot on your boot device. The default is **0**.

SCSI Device/Configuration Settings

SCSI Device/Configuration Settings allows you to configure certain parameters for each device on the SCSI bus. To configure a specific device, you must know the SCSI ID assigned to that device. If you are not sure of the SCSI ID, see "SCSI Disk Utilities" found earlier in this section.

- **Initiate Sync Negotiation** — This option determines whether the host adapter initiates synchronous data transfer negotiation (sync negotiation) between itself and the device. The default is **Yes**.

Sync negotiation is a SCSI feature that allows the host adapter and its attached SCSI devices to transfer data in synchronous mode. Synchronous data transfer is faster than asynchronous data transfer.

The host adapter always responds to sync negotiation if the SCSI device initiates it. If neither the host adapter nor the SCSI device initiates sync negotiation, data is transferred asynchronously.

Normally, you should leave **Initiate Sync Negotiation** enabled (a setting of **Yes**), because most SCSI devices support sync negotiation and because it allows for faster data transfer.



*NOTE: Some older SCSI-1 devices do not support sync negotiation. This may cause your computer to operate erratically or hang if **Initiate Sync Negotiation** is set to **Yes**. Set **Initiate Sync Negotiation** to **No** for these devices.*

- **Maximum Sync Transfer Rate (MB/sec)** — This option sets the maximum synchronous data transfer rate that the host adapter supports. The host adapter supports rates up to 80 megabytes per second (MB/sec). The default for the Adaptec AIC-7860 host adapter is **20**; the default for the AIC-7890 and 2940U2W host adapters is **80**.

If the host adapter is set so that it does not negotiate for synchronous data transfer, the maximum synchronous transfer rate is the maximum rate that the host adapter accepts from the device during negotiation. (This is standard SCSI protocol.)

- **Enable Disconnection** — This option (sometimes called *disconnect/reconnect*) determines whether the host adapter allows the SCSI device to disconnect from the SCSI bus. Enabling disconnection allows the host adapter to perform other operations on the SCSI bus while the SCSI device is temporarily disconnected. The default is **Yes**.

Leave **Enable Disconnection** set to **Yes** if two or more SCSI devices are connected to the host adapter. This optimizes SCSI bus performance. If only one SCSI device is connected to the host adapter, set **Enable Disconnection** to **No** to achieve slightly better performance.

- **Initiate Wide Negotiation** — This option determines whether the host adapter attempts 16-bit data transfer instead of 8-bit data transfer. The default for AIC-7890 and 2940U2W host adapters is **Yes**.



*NOTE: Some 8-bit SCSI devices may have trouble handling wide negotiation, which may result in erratic behavior or a hang condition. For these devices, set **Initiate Wide Negotiation** to **No**.*

When this option is set to **Yes**, the host adapter attempts 16-bit transfer. When this option is set to **No**, 8-bit data transfer is used unless the SCSI device itself requests wide negotiation. The effective transfer rate is doubled when 16-bit data transfer is used because the data path for wide SCSI is twice the size of normal 8-bit SCSI.

- **Send Start Unit** — This option determines whether the **start unit** command is sent to the SCSI device during the boot routine. The default for AIC-7860, AIC-7890, and 2940U2W host adapters is **Yes**.

Setting this option to **Yes** reduces the load on your computer's power supply by allowing the host adapter to start SCSI devices one at a time when you boot your system. When this option is set to **No**, the devices are allowed to start at the same time. Most devices require you to set a jumper before they can respond to this command.



*NOTE: For many devices, if **Send Start Unit** is set to **Yes**, the boot routine time will vary depending on how long it takes each drive to start.*

- **BIOS Multiple LUN Support** — This option provides support for peripherals that contain multiple SCSI devices, such as redundant arrays of independent disks (RAID) subsystems and CD-ROM changers. The default for AIC-7860, AIC-7890, and 2940U2W host adapters is **No**.
- **Include in BIOS Scan** — This option enables you to set whether the system BIOS scans this device during system start-up. The default for AIC-7860, AIC-7890, and 2940U2W host adapters is **Yes**.

Advanced Host Adapter Settings

Advanced Host Adapter settings should *not* be changed unless absolutely necessary. These values are set by Dell, and changing them may cause conflicts with the SCSI devices.

- **Reset SCSI Bus at IC Initialization** — This option enables the SCSI bus to be reset when the controller (integrated circuit [IC]) is initialized. The default for AIC-7860, AIC-7890, and 2940U2W host adapters is **Enabled**.
- **Extended BIOS Translation For DOS Drives > 1 GB** — This option determines whether extended translation is available for SCSI hard-disk drives with capacities greater than 1 gigabyte (GB). The default is **Enabled**.

When you partition a hard-disk drive larger than 1 GB, use the MS-DOS **fdisk** utility as you normally would. Because the cylinder size increases to 8 megabytes (MB) under extended translation, the partition size you choose must be a multiple of 8 MB. If you request a size that is not a multiple of 8 MB, **fdisk** rounds up to the nearest whole multiple of 8 MB.

- **Host Adapter BIOS** — This option enables or disables the host adapter BIOS. The default is **Enabled**.



NOTE: Several SCSISelect options are not valid unless the host adapter BIOS is enabled.

If you are booting from a SCSI hard-disk drive connected to the host adapter, the BIOS must be enabled. You should disable the host adapter BIOS if the peripherals on the SCSI bus (for example, CD-ROM drives) are all controlled by device drivers and do not need the BIOS.

- **Support Removable Disks Under BIOS As Fixed Disks** — This option controls which removable-media drives are supported by the host adapter BIOS. The default is **Boot Only**. The following choices are available.



CAUTION: If a removable-media SCSI device is controlled by the host adapter BIOS, do not remove the media while the drive is on or you may lose data. If you want to be able to remove media while the drive is on, install your removable-media device driver and set this option to Disabled.

- **Boot Only.** Only the removable-media drive designated as the boot device is treated as a hard-disk drive.
 - **All Disks.** All removable-media drives supported by the BIOS are treated as hard-disk drives.
 - **Disabled.** No removable-media drives are treated as hard-disk drives. In this situation, software drivers are needed because the drives are not controlled by the BIOS.
- **Display <Ctrl><a> Message During BIOS Initialization** — This option determines whether the Press <CTRL><A> for SCSISelect (TM) Utility. message appears on your screen during system start-up. The default is **Enabled**. If this setting is **Disabled**, you can still run the SCSISelect utility by pressing <Ctrl><a> after the host adapter BIOS banner appears.
 - **BIOS Support For Bootable CD-ROM** — This option determines whether the host adapter BIOS provides support for booting from a CD-ROM drive. The default is **Enabled**.

- **BIOS Support For Int13 Extensions** — This option determines whether the host adapter BIOS supports disks with more than 1024 cylinders. The default is **Enabled**.

Installation for Supported Windows NT Server Operating Systems

This section provides the following information about installing the Dell SCSI drivers for the supported Windows NT Server operating systems (for a list of the operating systems supported see “Supported Operating Systems” in Chapter 1):

- Installing the SCSI drivers
- Removing a host adapter
- Swapping a host adapter
- Troubleshooting a configuration if Windows NT fails to boot



NOTE: Refer to Dell's Microsoft Windows NT Server 4.0 Operating System Quick Installation Guide or Microsoft Windows NT Server, Enterprise Edition 4.0 Installation Information for instructions for installing or reinstalling the Windows NT operating system on your server. The following procedures focus specifically on the installation of SCSI drivers.

Installation Overview

The Windows NT driver diskettes you create for the Microsoft Windows NT Server operating system contain a number of files needed for driver installation. The following files are included on the diskettes:

- **aic78u2.sys** — Adaptec's driver for the 7890 SCSI controller and the AHA-2940U2W host adapter for Windows NT
- **aic78xx.sys** — Adaptec's driver for the 7860 SCSI controller for Windows NT
- **oemsetup.inf** — A file used by Windows NT Setup for driver installation
- **readme.txt** — A text file describing the Adaptec 78xx driver for Windows NT

If you have an optional RAID controller, you will also be using the **pedge.sys** file, the Windows NT driver for the RAID controller. Depending on the RAID controller you have, the driver may be on the *Dell OpenManage Server Assistant* CD or on a separate diskette included with the shipment.

Installing SCSI Drivers During Windows NT Installation

To install the SCSI drivers at the same time you are installing Windows NT, use the following procedure:

1. If you have not already done so, use the *Dell OpenManage Server Assistant* CD to create the Windows NT SCSI and video controller drivers diskette.



NOTE: If you have a RAID controller installed, you may have a RAID driver diskette included with your shipment. If so, use that diskette as noted during this procedure. If not, use the Dell OpenManage Server Assistant CD to create the RAID driver diskette.

2. Boot from the *Microsoft Windows NT Server* CD.



NOTE: In the following step, there is no prompt to press <F6>. Watch the messages on the screen carefully.

3. Press <F6> immediately when the following message is displayed:

```
Setup is inspecting your computer's hardware
configuration...
```

This disables automatic detection of SCSI devices by Windows NT. The following message appears:

```
Setup could not determine the type of one or more mass stor-
age devices installed in your system, or you have chosen to
manually specify an adapter.
```

A menu offers options for using a driver diskette or not specifying a device.

4. Press <s> for the **Specify Additional Device** option.

A list of supported SCSI host adapters appears.

5. Select **Other** and press <Enter>.

6. Insert the Windows NT driver diskette or the RAID controller driver diskette into the diskette drive and press <Enter>.



NOTE: Do not install video drivers at this time. They must be installed after Windows NT Service Pack 3.0 is installed.

7. Select the host adapter from the list.

For the AIC-7890 and AHA-2940U2W host adapters, select **Adaptec AHA-294xU2/295xU2/AIC-789x PCI Ultra 2 SCSI Controller (NT 4.0)**.

For the AIC-7860 host adapter, select **Adaptec AHA-290x/291x/294x/394x/494x/AIC-78xx PCI SCSI Controller (NT 4.0)**.

For the RAID controller, select **PowerEdge RAID II NT Driver** or other RAID driver.

8. Press <Enter>.

The driver is copied from the diskette to your system.

9. Repeat steps 4 through 8 for each SCSI host adapter installed on the system. If a driver supports more than one host adapter, the driver only needs to be installed one time.
10. Press <Enter> to continue with Windows NT Setup.
11. When you are prompted to install the Adaptec 7800 Family Manager Set for Windows NT 4.0, use the SCSI and video controller driver diskette you created for Windows NT from the *Dell OpenManage Server Assistant CD*.
12. When you are prompted to install the RAID controllers, use the RAID driver diskette you created for Windows NT from the *Dell OpenManage Server Assistant CD*.
13. Click **Yes** when prompted to restart the system, and remove the diskette from the diskette drive.

After the system reboots, the new drivers are active. Some drive assignments may have changed from the previous configuration. Be sure to complete the Windows NT installation by performing the following tasks:

- Install Windows NT Service Pack 3.0
- Install the video drivers
- Install network interface controller (NIC) drivers

Refer to the Windows NT installation documentation for details.

Removing a Host Adapter



CAUTION: If you have removed a host adapter but still have other host adapters of the same type installed in your computer, do not remove the device driver. The other host adapters still need the driver to function properly.

To remove a PCI SCSI controller, remove the expansion card from its slot when your computer is shut down. Windows NT boots and functions properly in this configuration. However, if an unused device driver remains on the system, a warning message is generated and an entry is made into the system log file every time you boot Windows NT. To eliminate the warning message, you must update the Windows NT software configuration as follows:

1. Click the **Start** button, point to **Settings**, and click **Control Panel**.
2. Double-click the **SCSI Adapter** icon.

The **SCSI Adapter** window appears.

Select the **Drivers** tab. A list of all installed host adapters appears.

3. Highlight the driver to be removed.

4. When you are sure you are removing the correct host adapter, click **Remove**.

Because SCSI device drivers are loaded during system start-up and because they may be needed to load Windows NT itself, a message may appear warning you that Windows NT may not start if you remove the SCSI adapter.

5. Confirm the removal by clicking **Yes**.
6. Return to step 3 if you want to remove driver support for other types of host adapters, or click **OK** to continue.
7. When the following message appears, click **OK** to exit the **Control Panel**:

The changes you have made will not take effect until the computer is restarted.

If this message does not appear, no changes have been made to the Windows NT system configuration.

8. Restart your computer.

Swapping a Host Adapter

The procedure for swapping a host adapter depends on whether the new host adapter uses the same device driver as the previous one.

If the same device driver is used, shut down the computer, physically swap out the host adapter, and restart the computer. The device driver for the previous host adapter will function correctly for the new host adapter. For example, because both the AIC-7890 host adapter and the AHA-2940U2W host adapter use the Adaptec **aic78u2.sys** driver, you can physically swap out those host adapters with no change in the device driver.

If the new host adapter does not use the same device driver as the previous one, add the device driver for the new host adapter while Windows NT is running and then make the hardware changes. Follow these steps to swap host adapters:

1. Install the device driver for the new host adapter.
 - a. Click the **Start** button, point to **Settings**, and click **Control Panel**.
 - b. Double-click the **SCSI Adapter** icon.
 - c. The **SCSI Adapter** window appears.
 - d. Click the **Drivers** tab. A list of all installed host adapters appears.
 - e. Highlight the driver to be added or insert the diskette containing the driver.
 - f. Click **Add**.

2. Shut down Windows NT and replace the existing host adapter.
3. Restart your computer and Windows NT.

Some drive assignments may have changed from the previous configuration.

It is not essential to remove the device driver for the host adapter you are replacing. Windows NT dynamically detects the absence or presence of host adapter hardware, and no problems should arise if you leave the existing device driver installed. You can remove the device driver later, after you have successfully rebooted Windows NT. However, if you leave the driver in, each time you boot the system you may receive an error message about the extra device driver. See the previous subsection, "Removing a Host Adapter."

Troubleshooting for Windows NT

The boot manager for Windows NT contains recovery logic to allow you to return to the last known good configuration. If you have changed your host adapter configuration and Windows NT no longer boots, follow these steps to recover:

1. Undo any hardware changes you have made to the computer since it was last operational.
2. Reboot the computer.

Watch the display carefully during start-up. If the following message appears, press the spacebar, press <l> at the next screen, and then follow the instructions on the screen to continue booting with the last known good configuration:

`Press spacebar NOW to invoke the Last Known Good menu`

3. When your computer is operational again, check all of the hardware and software configuration changes you want to make. Look specifically for conflicts with parts of the existing system configuration that are not being changed.

If you cannot determine the source of the error, contact Dell for assistance. See Chapter 12, "Getting Help," in the *Installation and Troubleshooting Guide* for instructions on contacting Dell for technical assistance.

Installation for Novell IntranetWare 4.11

This section provides the following information about installing the Dell SCSI drivers for IntranetWare:

- Creating the IntranetWare drivers diskettes
- Preparing the hard-disk drive
- Installing SCSI drivers during IntranetWare installation
- Installing the Dell-supplied Novell patches and Support Pack 5
- Installing symmetric multiprocessing (SMP) support
- Loading drivers automatically using **startup.ncf** and **autoexec.ncf**

- Optimizing performance
- Troubleshooting error messages generated during initialization

Installation Overview

The Dell SCSI drivers for IntranetWare support the optional Adaptec AHA-2940U2W and all Adaptec 78xx series SCSI controllers, are fully tested and approved for IntranetWare, and are available on the *Dell OpenManage Server Assistant* CD. You will need to create IntranetWare 4.11 diskettes containing these drivers if you have not already done so. Refer to the *Dell OpenManage Server Assistant* CD to create these diskettes.

The IntranetWare driver diskettes you create contain a number of files used by IntranetWare. During the IntranetWare installation process, you will be asked to select or use the following files:

- **aic78u2.ham** — IntranetWare driver for the AIC-7890 and AHA-2940U2W host adapters
- **aha2940.ham** — IntranetWare driver for the AIC-7860 host adapter
- **nwaspi.cdm** — Adaptec's device driver for a CD-ROM drive
- **cdrom.nlm** — File required by the IntranetWare bus interface

If you have an optional RAID controller, you will also be using the **pedge4x.ham** file, the IntranetWare driver for the RAID controller. Depending on the RAID controller you have, the driver may be on the *Dell OpenManage Server Assistant* CD or on a separate diskette included with the shipment.

In addition, the IntranetWare driver diskettes contain the driver-definition information files for both the 78xx Ultra2 SCSI series host adapters and the AHA-2940U2W host adapter. These files provide setup information to IntranetWare during installation so that IntranetWare can prompt you with parameters to be configured for these device drivers.



NOTE: Your system must have a bootable version of MS-DOS or Digital Research's DR-DOS installed before you can complete the IntranetWare installation.

After creating the driver diskettes, you will need to prepare the hard-disk drive and then install IntranetWare 4.11. Once IntranetWare is installed, you can then install Dell-supplied Novell patches and Support Pack 5, as well as SMP support. The following subsections describe these procedures in detail.



*NOTE: If the server has a RAID controller installed, you must set up the RAID controller and drives in a valid configuration **before** you perform the procedures in the following subsections. Refer to the RAID controller documentation to configure the controller and drives, and then return to this section.*

Creating the IntranetWare 4.11 Driver Diskettes

If you have not already done so, use the *Dell OpenManage Server Assistant* CD to create the IntranetWare SCSI and RAID drivers diskette. Refer to the *Dell OpenManage Server Assistant* CD to create this diskette.

If you have a RAID controller installed, you may have a RAID driver diskette included with your shipment. If so, use that diskette as the source of your RAID driver rather than the SCSI and RAID drivers diskette created from the *Dell OpenManage Server Assistant* CD.



NOTE: Label all driver diskettes. (For example, use the label IntranetWare 4.11 Driver Updates).

Once the diskettes are created, continue to the next subsection, "Preparing the Hard-Disk Drive for IntranetWare Installation."

Preparing the Hard-Disk Drive for IntranetWare Installation

To prepare the hard-disk drive for IntranetWare installation, you must create a utility partition on the drive, create the primary MS-DOS partition, format the MS-DOS partition, create the **c:\dos** and **c:\scsi** subdirectories, and install certain system files.

You do not need to create a utility partition if you are installing IntranetWare on your system for the first time. Dell shipped your system with the utility partition already created on the hard-disk drive; you can proceed to create the primary MS-DOS partition on the drive. If you are reinstalling IntranetWare, you will need to delete the utility partition and re-create it.



CAUTION: Do not perform these procedures if Dell installed IntranetWare 4.11 on your system. The Dell-installed version of IntranetWare already contains the SCSI drivers you need. If you partition and format drives that already contain data, the data will be overwritten and cannot be retrieved.

Follow these steps to prepare the hard-disk drive using the *Dell OpenManage Server Assistant* and *Dell IntranetWare Support* CDs:

1. Perform the following steps to create a utility partition:
 - a. Insert the *Dell OpenManage Server Assistant* CD into the server's CD-ROM drive and turn on (or reboot) the system.
 - b. From the *Dell OpenManage Server Assistant* CD main menu, select **Create utility partition** and press <Enter>.
 - c. At the **Welcome** screen, select **OK** and press <Enter>.
 - d. At the message `Installation completed successfully`, select **OK** and press <Enter>.
 - e. Select **Exit** and press <Enter>.



- f. At the **Exit Confirmation** dialog box, remove the *Dell OpenManage Server Assistant* CD, insert the *Dell IntranetWare Support* CD, select **OK**, and press <Enter> to reboot the server.
2. From the **Dell IntranetWare Support Menu**, type 1 to select **Create a primary DOS partition**.
3. From the **Hard-Drive Preparation Menu**, type 2 to select **Run FDISK in automated mode**.

*NOTE: Dell recommends running the **fdisk** utility in automated mode unless you need to specify a different size for the primary MS-DOS partition. Running the **fdisk** utility in automated mode creates a 25-MB partition.*

4. At the **Warning** screen, read the information and type *y* to continue.
The program partitions and then reboots the system.
5. From the **Dell IntranetWare Support Menu**, type 2 to select **Format primary DOS partition**.
6. When prompted, type *y* and press <Enter> to proceed with the format.
7. From the **Dell IntranetWare Support Menu**, type 3 to select **Copy DOS system files to hard-drive**.
8. Read the message that appears and type *y* to continue.

The message `FILE TRANSFER COMPLETE` appears and you are returned to the `a:\` prompt.

9. Remove the *Dell IntranetWare Support* CD from the drive and press <Ctrl><Alt> to reboot the system.

Your hard-disk drive has been prepared for IntranetWare installation. Continue to the next subsection, "Installing SCSI Drivers During IntranetWare 4.11 Installation."

Installing SCSI Drivers During IntranetWare 4.11 Installation

This section describes how to install the **aic78u2.ham** and **aha2940.ham** drivers at the same time you install IntranetWare. If you have a RAID controller, you should also install the **pedge4x.ham** driver during this process.

If IntranetWare is already installed and you want to install or update the **aic78u2.ham** and **aha2940.ham** drivers, refer to the *NetWare User's Guide* for installation instructions. Also, refer to the *NetWare User's Guide* for information about partitioning, creating a server name, and checking the Internetwork Packet Exchange (IPX) network number.

Follow these steps only if you are upgrading to IntranetWare or installing it for the first time:

1. Make backup copies of all IntranetWare diskettes and use those backup copies as your working diskettes.
2. Start the server.
3. Insert the *NetWare Operating System* CD into the CD-ROM drive.
4. Change to the CD-ROM drive prompt.
The installation files are located in the root directory on the CD-ROM drive.
5. Type `install` and press <Enter>.
6. Select a language at the language selection screen and press <Enter>.
7. Read and accept the license agreement to continue installation.
8. Select **NetWare Server Installation** as the type of installation and press <Enter>.
9. Select **NetWare 4.11** as the product to install and press <Enter>.
10. Press <F1> to view detailed explanations of the installation and upgrade options, select between a simple or custom installation, and press <Enter>.
11. When prompted, type a name for the server and press <Enter>.
12. When prompted to install IntranetWare SMP, select **No** and press <Enter>.



*NOTE: Even if you plan to install IntranetWare SMP, select **No** at this screen. The IntranetWare Support Pack 4 or later must be applied before IntranetWare SMP can be installed. To apply IntranetWare Support Pack 5, see "Installing the Dell-Supplied Novell Patches and Support Pack 5" found later in this section.*

The system searches for existing device drivers and hardware.

13. Press <F3> to continue through the next few screens until the **Choose the Server Drivers** screen appears.
14. Select **Select/Edit Disk or LAN drivers** and press <Enter>.
15. Select **Disk and CD-ROM Drivers** as the type of driver to install and press <Enter>. A list of installed drivers appears.



NOTE: Do not use the SCSI driver for the AIC-7860 host adapter that appears in the list of installed drivers.

16. Press <Insert> to install an unlisted driver.

17. Insert the backup copy of the IntranetWare 4.11 SCSI and RAID driver diskette into the diskette drive and press <Enter> to continue. A list of drivers on the diskette appears.



NOTE: If you have not already created this diskette, refer to the Dell OpenManage Server Assistant CD.

18. Select the **aic78u2.ham** driver and press <Enter>. The driver is copied to the hard-disk drive.



*NOTES: Specific help text for each driver appears in the middle of the screen as you scroll down the list. The **Loaded Drivers** window below the list of available drivers displays the names of drivers that are loaded and operational. For a new installation, this list is initially empty. For a selective installation, the list shows the drivers already running.*

If you have two controllers that use the same driver, such as two Adaptec AIC-7890 host adapters, you must load the same driver twice—once for each controller.

19. At the **Save existing file Y/N** prompt, type *y* or *n* as necessary and press <Enter>.
20. Press <Alt><Esc> to switch to the console prompt, type `load a:\aic78u2.ham`, and press <Enter>. A list of slot numbers separated by commas is displayed.
21. Write down all supported slot numbers listed and press <Esc> to clear the command line. Press <Alt><Esc> to return to the installation screen.
22. Select the field for the slot number, type the slot number for the driver, and press <Enter>.
23. Select **Save parameters and continue**, and then press <Enter>.
24. When prompted to select an additional disk driver, select **Yes** and press <Enter>.
25. Repeat steps 18 through 24 for the **aha2940.ham** driver.



*NOTE: If you have a RAID controller installed, you may have a RAID driver diskette included with your shipment. If so, return to step 17 and use that diskette as the source of your RAID driver. If not, repeat steps 18 through 24 for the **pedge4x.ham** driver, as well.*

26. When prompted to select an additional disk driver, select **No** and press <Enter>.
You now need to install the appropriate network adapter driver.
27. From the **Additional Driver Actions** menu, select **Continue Installation** and press <Enter>.

The **Network (LAN) Driver** box is highlighted.

28. Press <Enter> again to display a list of installed local area network (LAN) drivers.
29. Press <Insert> to install an unlisted driver.
30. Insert the backup copy of the IntranetWare 4.11 NIC driver diskette into the diskette drive and press <Enter> to continue. A list of LAN drivers on the diskette appears.
31. Note and select the name of the driver you need to install and press <Enter>. The driver is copied to the hard-disk drive.
32. At the **Save existing file Y/N** prompt, type *y* or *n* as necessary and press <Enter>. A LAN driver configuration screen appears.
33. Press <Alt><Esc> to switch to the console prompt, type `load driver_filename`, and press <Enter>. A list of slot numbers separated by commas is displayed.
34. Write down all slot numbers that are listed and press <Esc> to clear the command line. Press <Alt><Esc> to return to the installation screen.
35. Enter the appropriate values for the configuration parameters, including the slot number for the network adapter, pressing <Enter> after each entry.
36. Select **Save parameters and continue**, and then press <Enter>.
37. Repeat steps 27 through 36 for each network adapter in your system.
38. Select **Continue Installation** and press <Enter> to create disk partitions, system volumes, and NetWare Directory Services according to the instructions provided in the IntranetWare user's guide.
39. If prompted to edit the **startup.ncf** file, find the entry `load sgscsi.cdm` and replace it with `load scsihd.cdm`. Verify that the **load** command line and slot number for your host adapter are listed correctly in the **startup.ncf** file.

For further information about editing the **startup.ncf** file, see "Using startup.ncf and autoexec.ncf" found later in this document.

Your SCSI drivers have been installed. Continue to the next subsection, "Installing the Dell-Supplied Novell Patches and Support Pack 5."

Installing the Dell-Supplied Novell Patches and Support Pack 5

The following paragraphs provide instructions for installing IntranetWare patches and Support Pack 5.

Dell-Provided IntranetWare 4.11

If you purchased IntranetWare from Dell, the required Novell patches (including the latest revision of the IntranetWare Support Pack recommended by Dell) are provided on the *Dell IntranetWare Support CD*.

To install the patches supplied on the *Dell IntranetWare Support CD*, follow these steps:

1. Start IntranetWare.
2. Insert the *Dell IntranetWare Support CD* into the server's CD-ROM drive.
3. At the console prompt, type `load cdrom` and press <Enter>.
4. Type `cd mount nwscd` and press <Enter>.
5. Type `nwscd:\dpatch` and press <Enter>.

A menu lists several patches (including the IntranetWare Support Pack 5), a backup option for the files being replaced by the IntranetWare Support Pack 5, and a reboot option.

Dell recommends that you accept the defaults as displayed.

6. Read the list of options and press <F10> to accept them.
The program copies files to your hard-disk drive.
7. At the message `IntranetWare Support Package installation is complete!`, press <Enter>.
8. At the console prompt, type `down` and press <Enter> to return to "downed server" mode.
9. At the console prompt, type `exit` to return to the MS-DOS prompt.
10. Remove the *Dell IntranetWare Support CD*.
11. Reboot the server.

IntranetWare 4.11 From Sources Other Than Dell

If you purchased IntranetWare 4.11 from a source other than Dell, you must apply the IntranetWare Support Pack version 4 or later before IntranetWare SMP can be installed.

The current IntranetWare Support Pack is version 5 and is an MS-DOS-executable patch file (**iwsp5b.exe**) available for download from Novell's World Wide Web site at **www.novell.com**. For complete instructions on applying IntranetWare Support Pack 5, refer to the Novell documentation.

To install the IntranetWare Support Pack 5, follow these steps:

1. Start IntranetWare.
2. Load the Support Pack file onto a workstation that is attached to the PowerEdge server.

3. Copy the Support Pack file to a volume on the server.
4. Expand the file by typing `iwsp5b.exe`, and press <Enter>.
5. Follow the directions in the **iwsp5b.txt** file included with the Support Pack.

When Support Pack 5 has been applied, you can install SMP on your system.



Installing SMP Support

*NOTE: Before SMP can be installed on your system, you **must** apply the IntranetWare Support Pack 4 or later to the IntranetWare operating system. See "Installing the Dell-Supplied Novell Patches and Support Pack 5" found earlier in this chapter.*

To add SMP support to your IntranetWare installation, follow these steps:

1. Start IntranetWare.
2. At the IntranetWare console prompt, type `Load install` and press <Enter>.
3. From the installation screen that appears, select **Multi CPU Options** and press <Enter>.
4. From the **SMP Installation Options** screen, select **Select a Platform Support-Module** and press <Enter>.
5. From the **Select a Driver** screen, select **MPS14.PSM** and press <Enter>.
A confirmation screen asks if you want to load the selected module.
6. Select **Yes** and press <Enter>.
A message screen appears.
7. Press <Enter> to continue and then <Alt><Esc> to exit to the console prompt.
8. Type `down` to down the server and then `exit` to exit to MS-DOS.
9. Reboot the system to enable SMP support.

Using startup.ncf and autoexec.ncf

The **startup.ncf** and **autoexec.ncf** files contain a set of commands that are executed during the boot routine. The **startup.ncf** file contains commands to load the disk drivers. Once **startup.ncf** loads disk drivers, control is passed to the **autoexec.ncf** file to complete the boot routine. For additional information on the **startup.ncf** and **autoexec.ncf** files, refer to your IntranetWare documentation.

To automatically load the **aic78u2.ham** driver during the boot routine, the **startup.ncf** file must contain a **load** command line that specifies the location of the driver on the hard-disk drive and any available options. To find the slot number, type `load a:\nwserver\aic78u2.ham` at the console prompt and press <Enter>. A list of

slot numbers separated by commas is displayed. Press <Esc> to clear the command line.



*NOTE: To load the driver from your hard-disk drive, the **aic78u2.ham** driver and **nwaspi.cdm** module must be copied from your IntranetWare driver diskette to a directory on your hard-disk drive (usually the server's start-up directory [for example, **c:\nwserver**]).*

The syntax to load the **aic78u2.ham** driver follows:

load [pathname]\aic78u2.ham [options] slot=x

For example, the command line to load the driver from the **c:\nwserver** directory with the **verbose=** option on and a slot number of 10002 follows:

```
load c:\nwserver\aic78u2.ham verbose=y slot=10002
```



*NOTE: For each Adaptec 78xx host adapter installed, a separate **load** command line must be included in the **startup.ncf** file. The slot number (**slot=**) identifies the specific adapter.*

To modify the **startup.ncf** file, follow these steps:

1. At the IntranetWare prompt, type `install` and press <Enter>.
2. Choose the menu selection that allows you to edit the **startup.ncf** file.
3. Make the necessary changes. When you are finished, press <F10>.

Using Drives Tested and Approved for IntranetWare

To be fully certified as IntranetWare "Yes, Tested and Approved," a drive and host adapter must both pass a qualification process that takes place before you see the product. The goals of IntranetWare testing are to simplify installation and provide the highest quality disk subsystem.

Adaptec 78xx series host adapters and their drivers are fully tested and approved for IntranetWare. This means that you can purchase a IntranetWare drive (certified as "Yes, Tested and Approved") from a vendor, connect it to your system or host adapter, partition it, and create a volume without any compatibility concerns.



NOTE: Dell recommends using only Dell-tested drives.

Adaptec's **aic78u2.ham** driver module is flexible enough to allow you to connect SCSI drives that are tested and approved for IntranetWare, as well as standard SCSI drives, to a single host adapter. The driver registers each hard-disk drive accordingly.

Drive registration is a user-transparent process; no user interaction is required. You can tell that the drive has been detected as IntranetWare-tested and IntranetWare-approved if the message `NetWare Yes Tested and Approved` is included in the drive description string that appears when you run **monitor.nlm** (disk options).

Setting Up a CD-ROM Drive With IntranetWare 4.11

To use a CD-ROM drive with IntranetWare, follow these steps:

1. Load **aha2940.ham** by entering the following command line:

```
load [pathname] \aha2940.ham slot=x
```

2. Load **aspicd.cdm** by entering the following command line:

```
load [pathname] nwaspi.cdm
```

*NOTE: If **aspicd.cdm** does not work, unload it and load it again. The first load initializes the host adapter; unloading and reloading allows the initialization to be completed.*

3. Load **cdrom.nlm** by entering the following command line:

```
load [pathname] cdrom.nlm
```

4. Enter the following line at the prompt, and then note the number and name of the CD that appears:

```
cd device list
```

5. Enter the number and volume name of the CD at the command line:

```
cd mount [number] [name]
```

The CD-ROM drive is now ready to be accessed as a volume.



Optimizing Performance

The Adaptec 78xx SCSI bus-mastering firmware increases the SCSI performance of the Adaptec 78xx series host adapters under multitasking environments. The firmware uses a paging mechanism to handle up to 255 SCSI commands simultaneously. The sequencer can simultaneously manage up to 32 tagged, or 2 nontagged, SCSI commands for each SCSI device, up to a limit of 255 SCSI commands. The firmware can queue as many commands as the operating system is able to send to the host adapter. To set this feature, enter the following command:

```
max_tags=n
```

In general, a low number for the **max_tags** option gives better sequential performance. This value varies with the level of random disk accesses and drive characteristics.

*NOTE: A large value for **max_tags** can cause starvation problems with some drives.*



Troubleshooting for IntranetWare

Any error that occurs while the driver is initializing prevents the driver from loading. If an error does occur, the driver causes the system to beep and display a numbered error message:

```
xxx message
```

The *xxx* indicates the error code, and *message* is a line describing the error. The error codes are divided into three categories:

- 000-099 — Non-host-adapter-specific
- 100-299 — Host-adapter-specific
- 300-999 — Reserved

Specific error codes, such as those in the following subsections, appear only if you have installed the host adapters and drivers that generate them.

Non-Host-Adapter-Specific Error Codes

The following error codes alert you to error conditions caused by factors not related to the host adapter:

000 Failed ParseDriverParameters call

A call to IntranetWare's ParseDriverParameters routine has failed for some unknown reason. The command line contains errors, or you pressed <Esc> at the port or slot prompt.

001 Unable to reserve hardware, possible conflict

The driver failed in its attempt to reserve the host adapter's hardware settings (that is, direct memory access [DMA] and interrupt request [IRQ] settings). Another card in your system may be causing a conflict with the host adapter.

002 NetWare rejected card Failed AddDiskSystem call

The driver failed in its attempt to register the host adapter with IntranetWare. The file server may not have enough memory.

003 Invalid command line option entered > option

An invalid option was entered on the command line. The invalid option that was entered is displayed.

004 Invalid command line, please enter correctly

The driver was unable to understand the command line options you entered. Be sure you have entered these options correctly.

Host-Adapter-Specific Error Codes

The following error codes alert you to error conditions caused by factors related to the host adapter:

200 No host adapter found for this driver to register

No Adaptec 78xx host adapter was found in your system for the driver to register. Be sure the host adapter is properly configured and properly seated in the slot.

203 Invalid 'device' setting

You have entered an invalid slot setting on the command line. You can only enter slot numbers for valid host adapters. If you load without the slot option, you will be prompted to enter a valid value.

204 Invalid 'verbose' setting, use 'y'

You can only enter `y` for this option (**verbose=y**).

205 Invalid 'removable' setting, use 'off'

You can only enter `off` for this option (**removable=off**).

206 Invalid 'fixed_disk' setting, use 'off'

You can only enter `off` for this option (**fixed_disk=off**).

208 SCSI present but not enabled/configured for PCI

A host adapter is present, but its bus or device entry has not been enabled.



CHAPTER 4

Using the System Setup Program

Each time you turn on or reboot your computer system, the system compares the hardware installed in the system to the hardware listed in the system configuration information stored in nonvolatile random-access memory (NVRAM) on the system board. If the system detects a discrepancy, it generates error messages that identify the incorrect configuration settings. The system then prompts you to enter the System Setup program to correct the setting.

You can use the System Setup program as follows:

- To change the system configuration information after you add, change, or remove any hardware in your system
- To set or change user-selectable options—for example, the time or date on your system
- To enable or disable all integrated devices in your system



CAUTION: Whenever you make changes to the System Setup program or add, reposition, or remove Industry-Standard Architecture (ISA) expansion cards, add or remove memory, or change settings for built-in devices, you must run the Resource Configuration Utility (RCU), make any necessary changes, and save the system configuration information. Failure to do so may cause resource conflicts between Peripheral Component Interconnect (PCI) devices (such as PCI expansion cards, the built-in video controller, or the built-in small computer system interface [SCSI] host adapter). See “Configuring ISA and PCI Expansion Cards” in Chapter 5 for more information about how PCI devices are configured based on settings in the RCU.

You can view the current settings any time you run the System Setup program. When you change a setting, the system reboots automatically so that the change can take effect.

After you set up your system, run the System Setup program to familiarize yourself with your system configuration information and optional settings. Dell recommends that you print the System Setup screens (by pressing the <Print Screen> key) or write down the information for future reference.

Before you use the System Setup program, you need to know the kind of diskette drive(s) and hard-disk drive(s) installed in your computer. If you are unsure of any of this information, see the Manufacturing Test Report that was shipped with your system. You can access the Manufacturing Test Report in the **Dell Accessories** folder.

Entering the System Setup Program

Enter the System Setup program as follows:

1. Turn on your system.
If your system is already on, shut it down and then turn it on again.
2. Press <Ctrl><Alt><Enter> immediately after you see the following message:

Press <Ctrl><Alt><Enter> for System Setup

If you wait too long and your operating system begins to load into memory, *let the system complete the load operation*; then shut down the system and try again.



NOTE: To ensure an orderly system shutdown, consult the documentation that accompanied your operating system.

You can also enter the System Setup program by responding to certain error messages. See “Responding to Error Messages” at the end of this chapter.

System Setup Screens

The two System Setup screens, Page 1 and Page 2, display the current setup and configuration information and optional settings for your system. Typical examples are illustrated in Figure 4-1. Information on the two System Setup screens is organized in five boxed areas:

- Title box

The box at the top of both screens lists the system name, page number (Page 1 or Page 2), and the revision number of the basic input/output system (BIOS).

- Configuration options

The box on the left half of both screens lists the categories that define the installed hardware in your computer.

Fields beside the categories contain options or values; those that appear bright on the screen can be changed. Options or values that you cannot change because they are determined by the system appear less bright.

Some categories have multiple fields, which may show options or values as bright or less bright depending upon what options or values you entered in other fields.

- Help

The box on the upper-right half of both screens displays help information for the category with a currently highlighted field.

- System data

The box in the lower-right corner of both screens displays information about your system.















- Key functions

The line of boxes across the bottom of both screens lists keys and their functions within the System Setup program.

Using the System Setup Program

Table 4-1 lists the keys you use to view or change information on the System Setup screens and to exit the program.

Table 4-1. System-Setup Navigation Keys

Keys	Action
 or 	Moves to the next field.
  or 	Moves to the previous field.
 or 	Cycles through the options in a field. In many fields, you can also type the appropriate value.
 or 	Scrolls through help information.
 	Switches between Pages 1 and 2.
	Exits the System Setup program and reboots the system if any changes were made.
 	Exits the System Setup program and reboots the system, implementing any changes you have made.

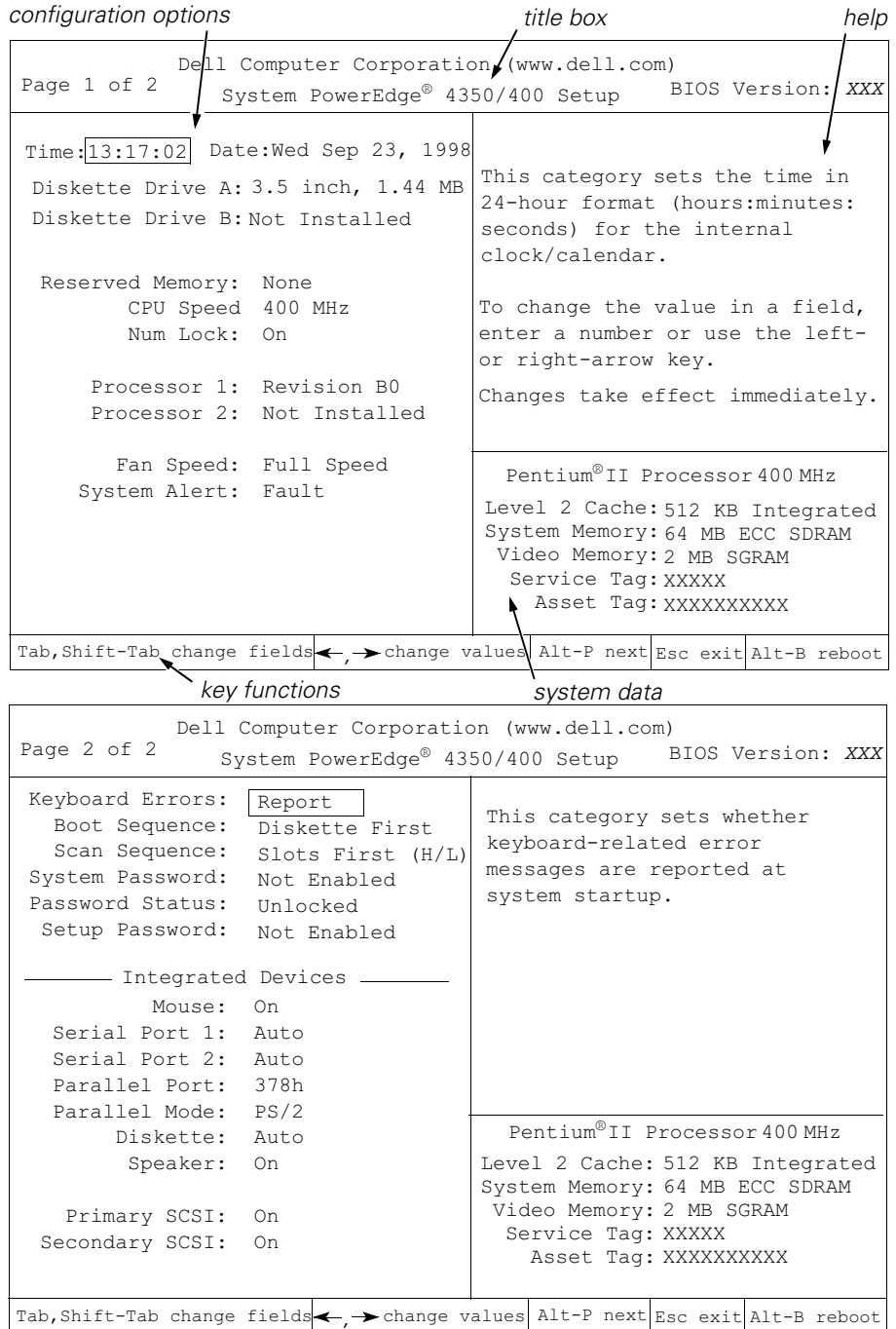

Figure 4-1. System Setup Screens

System Setup Options

The following subsections explain in detail each of the options on the System Setup screens:

Time

Time resets the time on the computer's internal clock.

Time is kept in a 24-hour format (*hours:minutes:seconds*). To change the time, press the right-arrow key to increase the number in the highlighted field or press the left-arrow key to decrease the number. If you prefer, you can type numbers in each of the appropriate fields.

Date

Date resets the date on the computer's internal calendar.

Your system automatically displays the day of the week corresponding to the settings in the three fields that follow (*month, day-of-month, and year*).

To change the date, press the right-arrow key to increase the number in the highlighted field or press the left-arrow key to decrease the number. If you prefer, you can type numbers in the *month* and *day-of-month* fields.

Diskette Drive A and Diskette Drive B

Diskette Drive A and **Diskette Drive B** identify the type of diskette drive installed in your computer.



NOTE: To ensure commonality across the Dell PowerEdge family of servers, the BIOS used in the PowerEdge 4350 system is the same as that used in other PowerEdge servers. Thus, the PowerEdge 4350 system BIOS provides support for dual diskette drive configurations—as in other PowerEdge servers—even though there is no available slot in the PowerEdge 4350 chassis to install a second diskette drive.

Diskette Drive A is the 3.5-inch diskette drive installed in the vertical drive slot to the left of the hard-disk drives. Slot space for a second diskette drive is not provided, so **Diskette Drive B** is set to **Not Installed**.

The available settings for these options are:

- **3.5 Inch, 720 KB**
- **3.5 Inch, 1.44 MB**
- **5.25 Inch, 360 KB**
- **5.25 Inch, 1.2 MB**
- **Not Installed**

Reserved Memory

Reserved Memory allows you to designate a region of system board memory that can be supplied by an expansion card. You should not enable the reserved memory feature unless you are using an expansion card that requires special addressing.

For example, you may have a memory expansion card that needs to be addressed starting at 15 megabytes (MB). Selecting the **15M - 16M** setting for **Reserved Memory** specifies that the base memory from 15 to 16 MB comes from the memory expansion card (the base memory below the 15-MB address comes from the dual-inline memory modules [DIMMs] on the system board).

Reserved Memory has the following settings:

- **None** (the default)
- **15M - 16M**

CPU Speed

CPU Speed indicates the processor speed at which your system boots.

Press the left- or right-arrow key to toggle **CPU Speed** between the resident micro-processor's rated speed (the default) and a lower speed. This feature should not be used under normal operations.

Num Lock

Num Lock determines whether your system boots with the Num Lock mode activated on 101- or 102-key keyboards (it does not apply to 84-key keyboards).

When Num Lock mode is activated, the rightmost bank of keys on your keyboard provides the mathematical and numeric functions shown at the tops of the keys. When Num Lock mode is turned off, these keys provide cursor-control functions according to the label on the bottom of each key.

Processor 1 and Processor 2

Processor 1 and **Processor 2** display the version or stepping number of each processor slot in the system. These options have no user-selectable settings.

Fan Speed

Fan Speed has the following settings:

- **Full Speed** (the default) provides maximum cooling.
- **Noise Reduced** enables quiet-mode operation.

System Alert

System Alert has the following settings:

- **Fault** (the default) causes the system light-emitting diode (LED) to flash only when a critical error threshold has been passed.
- **Warning** causes the system LED to flash as soon as a noncritical error threshold has been passed.

Keyboard Errors

Keyboard Errors enables or disables reporting of keyboard errors during the power-on self-test (POST), which is a series of tests that the system performs on the hardware each time you turn on the system or press the reset button.

This option is useful when applied to self-starting servers or host systems that have no permanently attached keyboard. In these situations, selecting **Do Not Report** suppresses all error messages relating to the keyboard or to the keyboard controller during POST. This option does not affect the operation of the keyboard itself if a keyboard is attached to the computer.

Boot Sequence

Boot Sequence can be set to **Diskette First** (the default) or to **Hard Disk Only**.

The term *boot* refers to the system's start-up procedure. When turned on, the system "bootstraps" itself into an operational state by loading into memory a small program, which in turn loads the necessary operating system. **Boot Sequence** tells the system where to look for the files that it needs to load.



*NOTE: If a bootable CD-ROM is in the CD-ROM drive, the system will boot from the CD-ROM, ignoring any value in **Boot Sequence**. If there is no bootable CD-ROM, **Boot Sequence** will control whether the system boots from a diskette or a hard-disk drive.*

Diskette First

Selecting **Diskette First** causes the system to try booting from drive A first. If the system finds a diskette that is not bootable in the drive or finds a problem with the drive itself, it displays an error message. If it does not find a diskette in the drive, the system tries to boot from the CD-ROM, then from the hard-disk drive (drive 0), and finally from the Plug and Play network adapters.

Hard Disk Only

Selecting **Hard Disk Only** causes the system to attempt to boot first from the hard-disk drive and then from the Plug and Play network adapters in the order found.

Scan Sequence

This option determines the order in which PCI devices are scanned by the system, and it allows you to select the built-in SCSI controller or an optional PCI expansion-card SCSI controller as the boot device. The options are:

- **Embedded Devices First**
- **Slots First (H/L)** (the default)
- **Slots First (L/H)**

When the internal SCSI drives are connected to a SCSI controller on the system board, select **Embedded Devices First** to boot from these drives.

When the internal SCSI drives are connected to a PCI RAID controller, select **Slots First** to boot from these drives. If the PCI RAID controller is in slot 6, select **High/Low**. If the controller is in slot 1, select **Low/High**.

System Password

System Password displays the current status of your system's password security feature and allows you to assign and verify a new password. No one can assign a new password unless the current status is **Not Enabled**, which is displayed in bright characters.

The settings for the **System Password** are:

- **Not Enabled** (the default)
- **Enabled**
- **Disabled by Jumper** (jumper removed)



NOTE: Read "Using the System Password Feature" found later in this chapter for instructions on assigning a system password and using or changing an existing system password. See "Disabling a Forgotten Password" found later in this chapter for instructions on disabling a forgotten system password.

Password Status

When **Setup Password** is set to **Enabled**, **Password Status** allows you to prevent the system password from being changed or disabled at system start-up.

To lock the system password, you must first assign a password in **Setup Password** and then change **Password Status** to **Locked**. In this state, the system password cannot be changed through **System Password** and cannot be disabled at system start-up by pressing <Ctrl><Enter>.

To unlock the system password, you must enter the setup password in **Setup Password** and then change **Password Status** to **Unlocked**. In this state, the system password can be disabled at system start-up by pressing <Ctrl><Enter> and then changed through **System Password**.

Setup Password

Setup Password lets you restrict access to your computer's System Setup program in the same way that you restrict access to your system with the system password feature. The settings are:

- **Not Enabled** (the default)
- **Enabled**
- **Disabled by Jumper** (jumper removed)



NOTE: Read "Using the Setup Password Feature" found later in this chapter for instructions on assigning a setup password and using or changing an existing setup password. See "Disabling a Forgotten Password" found later in this chapter for instructions on disabling a forgotten setup password.

Mouse

Mouse enables or disables the system's built-in Personal System/2 (PS/2)-compatible mouse port. Disabling the mouse allows an expansion card to use IRQ12.

Serial Port 1 and Serial Port 2

Serial Port 1 and **Serial Port 2** configure the system's built-in serial ports. These options can be set to **Auto** (the default) to automatically configure a port, to a particular designation (**COM1** or **COM3** for **Serial Port 1**; **COM2** or **COM4** for **Serial Port 2**), or to **Off** to disable the port.

If you set a serial port to **Auto** and add an expansion card containing a port configured to the same designation, the system automatically remaps the built-in port to the next available port designation that shares the same interrupt request (IRQ) setting as follows:

- COM1 (input/output [I/O] address 3F8h), which shares IRQ4 with COM3, is remapped to COM3 (I/O address 3E8h).
- Likewise, COM2 (I/O address 2F8h), which shares IRQ3 with COM4, is remapped to COM4 (I/O address 2E8h).



*NOTE: When two COM ports share an IRQ setting, you can use either port as necessary, **but you may not be able to use them both at the same time**. If the second port (COM3 or COM4) is also in use, the built-in port is turned off.*

Parallel Port

Parallel Port configures the system's built-in parallel port. **Parallel Port** can be set to **378h** (the default), to alternate addresses **278h** or **3BCh**, or to **Off** to disable the port.



*NOTE: Do not set **Parallel Port** to **278h** if you have an Extended Capabilities Port (ECP) device connected to the port.*

Parallel Mode

Parallel Mode controls whether the system's built-in parallel port acts as an AT-compatible (unidirectional) or PS/2-compatible (bidirectional) port.

Set **Parallel Mode** according to the type of peripheral device connected to the parallel port. To determine the correct mode to use, see the documentation that came with the device.

Diskette

Diskette controls the operation of the system's built-in diskette drive controller.

With **Auto** (the default) selected, the system turns off the built-in diskette drive controller when necessary to accommodate a controller card installed in an expansion slot.

With **Write Protect** selected, nothing can be written to diskette drives using the system's built-in diskette drive controller. (The system can still read from the drives.) When this option is selected, the **Auto** option (whereby the system turns off the built-in diskette drive controller as necessary) is also in effect.

Selecting **Off** turns off the built-in diskette controller; this option is used primarily for troubleshooting purposes.

Speaker

Speaker controls the built-in speaker. The default is **On**. Rebooting the system is required for a change to take effect.

Primary SCSI and Secondary SCSI

Primary SCSI and **Secondary SCSI** turn the respective SCSI controller on or off. Selecting **On** (the default option) enables the built-in PCI SCSI controller and scans the associated read-only memory (ROM). For the system to boot from a drive attached to the built-in SCSI controller, the drive must be enabled. Selecting **Off** causes the BIOS to mask the presence of a device.

System Data

The following fields, which are not selectable, display information about the system:

- The processor line displays the microprocessor type and speed.
- **Level 2 Cache** displays the size of the integrated cache (512 kilobytes [KB]).
- **System Memory** indicates the entire amount of installed memory detected in your system, except for memory on Expanded Memory Specification (EMS) expansion cards. After adding memory, check **System Memory** to confirm that the new memory is installed correctly and is recognized by the system.

- **Video Memory** displays the amount of video memory detected in your system.
- **Service Tag** displays the system's five-character service tag number, which was programmed into NVRAM by Dell during the manufacturing process. Refer to this number during technical assistance or service calls. The service tag number is also accessed by certain Dell support software, including the diagnostics software.
- **Asset Tag** displays the customer-programmable asset tag number for the system if an asset tag number has been assigned. You can use the Asset Tag utility, which is included with your software support utilities, to enter an asset tag number up to ten characters long into NVRAM. See "Asset Tag Utility" in Chapter 2 for information on loading the Asset Tag utility.

Using the System Password Feature



CAUTION: The password features provide a basic level of security for the data on your system. However, they are not foolproof. If your data requires more security, it is your responsibility to obtain and use additional forms of protection, such as data encryption programs.

Your Dell system is shipped to you without the system password feature enabled. If system security is a concern, you should operate your system only with system password protection.

You can assign a system password, as described in the next subsection, "Assigning a System Password," whenever you use the System Setup program. After a system password is assigned, only those who know the password have full use of the system.

When **System Password** is set to **Enabled**, the computer system prompts you for the system password just after the system boots.

To change an existing system password, you must know the password (see "Deleting or Changing an Existing System Password" found later in this section). If you assign and later *forget* a system password, you need to be able to remove the computer cover to change a jumper setting that disables the system password feature (see "Disabling a Forgotten Password" found later in this chapter). Note that when you erase the system password, you erase the setup password at the same time.



CAUTION: If you leave your system running and unattended without having a system password assigned, or if you leave your computer unlocked so that someone can disable the password by changing a jumper setting, anyone can access the data stored on your hard-disk drive.



NOTE: The system password is overridden by the setup password.

Assigning a System Password

Before you can assign a system password, you must enter the System Setup program and check **System Password**.

When a system password is assigned, **System Password** is **Enabled**. When the system password feature is disabled by a jumper setting on the system board, the status shown is **Disabled by Jumper**. *You cannot change or enter a new system password if either of these options is displayed.*

When no system password is assigned and the password jumper on the system board is in the enabled position (its default), the status shown for **System Password** is **Not Enabled**. *Only when **System Password** is set to **Not Enabled** can you assign a system password, using the following procedure:*

1. Verify that **Password Status** is set to **Unlocked**.

For instructions on changing the setting for **Password Status**, see “Password Status” found earlier in this chapter.

2. Highlight **System Password**, and then press the left- or right-arrow key.

The heading changes to **Enter Password**, followed by an empty seven-character field in square brackets.

3. Type your new system password.

You can use up to seven characters in your password.

As you press each character key (or the spacebar key for a blank space), a placeholder appears in the field.

The password assignment operation recognizes keys by their location on the keyboard, without distinguishing between lowercase and uppercase characters. For example, if you have an *M* in your password, the system recognizes either *M* or *m* as correct.

Certain key combinations are not valid. If you enter one of these combinations, the speaker emits a beep.

To erase a character when entering your password, press the <Backspace> key or the left-arrow key.



NOTE: To escape from the field without assigning a system password, press the <Tab> key or the <Shift><Tab> key combination to move to another field, or press the <Esc> key at any time prior to completing step 5.

4. Press <Enter>.

If the new system password is less than seven characters, the whole field fills with placeholders. Then the category heading changes to **Verify Password**, followed by another empty seven-character field in square brackets.

5. To confirm your password, type it a second time and press <Enter>.

The password setting changes to **Enabled**. Your system password is now set; you can exit the System Setup program and begin using your system. Note, however, that password protection does not take effect until you reboot the system by turning the system off and then on again.

Using Your System Password to Secure Your System

Whenever you turn on your system or reboot by pressing the <Ctrl><Alt> key combination, the following prompt appears when **Password Status** is set to **Unlocked**:

Type in the password and...

- press <ENTER> to leave password security enabled.

- press <CTRL><ENTER> to disable password security.

Enter password:

If **Password Status** is set to **Locked**, the following prompt appears:

Type the password and press <Enter>.

After you type the correct system password and press <Enter>, your system boots and you can use the keyboard and/or mouse to operate your system as usual.



NOTE: If you have assigned a setup password (see "Using the Setup Password Feature" found later in this chapter), the system accepts your setup password as an alternate system password.

If a wrong or incomplete system password is entered, the following message appears on the screen:

```
** Incorrect password. **
```

Enter password:

If an incorrect or incomplete system password is entered again, the same message appears on the screen.

The third and subsequent times an incorrect or incomplete system password is entered, the system displays the following message:

```
** Incorrect password. **
```

```
Number of unsuccessful password attempts: 3
```

```
System halted! Must power down.
```

The number of unsuccessful attempts made to enter the correct system password can alert you to an unauthorized person attempting to use your system.

Even after your system is turned off and on, the previous message is displayed each time an incorrect or incomplete system password is entered.



*NOTE: You can use **Password Status** in conjunction with **System Password** and **Setup Password** to further protect your system from unauthorized changes. For more information, see "Password Status" found earlier in this chapter.*

Deleting or Changing an Existing System Password

To delete or change an existing system password, perform the following steps:

1. Enter the System Setup program, and verify that the **Password Status** category is set to **Unlocked**.

Enter the System Setup program by pressing the <Ctrl><Alt><Enter> key combination. Press the <Alt><p> key combination to move to Page 2 of the **System Setup** screens. For instructions on changing the setting for **Password Status**, see "Password Status" found earlier in this chapter.

2. Reboot your system to force it to prompt you for a system password.
3. When prompted, type the system password.
4. Press the <Ctrl><Enter> key combination to disable the existing system password, instead of pressing <Enter> to continue with the normal operation of your system.
5. Confirm that **Not Enabled** is displayed for the **System Password** category of the System Setup program.

If **Not Enabled** appears in the **System Password** category, the system password has been deleted. If you want to assign a new password, continue to step 6. If **Not Enabled** is *not* displayed for the **System Password** category, press the <Alt> key combination to reboot the system, and then repeat steps 3 through 5.

6. To assign a new password, follow the procedure in "Assigning a System Password" found earlier in this section.

Using the Setup Password Feature

Your Dell system is shipped to you without the setup password feature enabled. If system security is a concern, you should operate your system with setup password protection.

You can assign a setup password, as described in the next subsection, "Assigning a Setup Password," whenever you use the System Setup program. After a setup password is assigned, only those who know the password have full use of the System Setup program.

To change an existing setup password, you must know the setup password (see "Deleting or Changing an Existing Setup Password" found later in this section). If you assign and later *forget* a setup password, you need to remove the computer cover to change a jumper setting that disables the setup password feature (see "Disabling a Forgotten Password" found later in this chapter). Note that you erase the *system password* at the same time.

Assigning a Setup Password

A setup password can be assigned (or changed) only when **Setup Password** is set to **Not Enabled**. To assign a setup password, highlight **Setup Password** and press the left- or right-arrow key. The system prompts you to enter and verify the password. If a character is illegal for password use, the system emits a beep.



NOTES: The setup password can be the same as the system password.

If the two passwords are different, the setup password can be used as an alternate system password. However, the system password cannot be used in place of the setup password.

After you verify the password, **Setup Password** changes to **Enabled**. The next time you enter the System Setup program, the system prompts you for the setup password.

A change to **Setup Password** becomes effective immediately (rebooting the system is not required).

Operating With a Setup Password Enabled

If **Setup Password** is set to **Enabled**, you must enter the correct setup password before you can modify the majority of the System Setup options.

When you start the System Setup program, Page 2 of the System Setup screens appears with **Setup Password** highlighted, prompting you to type the password.

If you do not enter the correct password in three attempts, the system lets you view, but not modify, the System Setup screens—with the following exceptions:

- You can still modify **Date, Time, CPU Speed, Num Lock, and Speaker**.
- If **System Password** is not enabled and is not locked via **Password Status**, you can assign a system password (however, you cannot disable or change an existing system password).



*NOTE: You can use **Password Status** in conjunction with **Setup Password** to protect the system password from unauthorized changes. For more information, see "Password Status" found earlier in this chapter.*

Deleting or Changing an Existing Setup Password

To delete or change an existing setup password, perform the following steps:

1. Enter the System Setup program.
2. Highlight **Setup Password**, and press the left- or right-arrow key to delete the existing setup password.

The setting changes to **Not Enabled**.

3. If you want to assign a new setup password, follow the procedure in "Assigning a Setup Password" found earlier in this section.

Disabling a Forgotten Password

If you forget your system or setup password, you cannot operate your system or change settings in the System Setup program, respectively, until a trained service technician opens the computer chassis, changes the password jumper setting to disable the passwords, and erases the existing passwords. This procedure is described in "Disabling a Forgotten Password" in Appendix B of the *Installation and Troubleshooting Guide*.

Responding to Error Messages

If an error message appears on your monitor screen while the system is booting, make a note of the message. Then, before entering the System Setup program, refer to "System Beep Codes" and "System Messages" in Chapter 3 of the *Installation and Troubleshooting Guide* for an explanation of the message and suggestions for correcting any errors. (An exception to this routine: It is normal to receive an error message the first time you boot your system after installing a memory upgrade. In that situation, do not refer to "System Beep Codes" and "System Messages." Instead, follow the instructions in "Performing a Memory Upgrade" in Chapter 8 of the *Installation and Troubleshooting Guide*.)

Some error conditions give the user the following options:

- Press <F1> if you wish to continue; or
- Press <F2> if you wish to run the System Setup program and update the configuration data.



CHAPTER 5

Using the Resource Configuration Utility

The Resource Configuration Utility (RCU) is used to tell the system what expansion cards are installed and which expansion slots they occupy. With this information, the system automatically configures Plug and Play expansion cards and Peripheral Component Interface (PCI) expansion cards and can tell you how to configure non-Plug and Play Industry-Standard Architecture (ISA) expansion cards manually by setting jumpers or switches. Before your system was shipped from Dell, a technician used the RCU to enter the correct information for the expansion cards initially installed in your computer.

The RCU also monitors the resources required by any installed PCI expansion card. After installing or moving a PCI expansion card, you should run the RCU to update the system's database of available system resources stored in nonvolatile random-access memory (NVRAM).



CAUTION: Whenever you make changes to the System Setup program or add, reposition, or remove ISA expansion cards, add or remove memory, or change settings for built-in devices, you must run the RCU, make any necessary changes, and save the system configuration information. Failure to do so may cause resource conflicts between PCI devices (such as PCI expansion cards, the built-in video controller, or the built-in small computer system interface [SCSI] host adapter). See "Configuring ISA and PCI Expansion Cards" in this chapter for more information about how PCI devices are configured based on settings in the RCU.

Configuring ISA and PCI Expansion Cards

Whenever you add, remove, or reposition an ISA expansion card, use the RCU to reconfigure your system. The utility reads the card's corresponding configuration (.cfg) file, which describes the card's characteristics and required system resources, and then uses this information to create a conflict-free configuration.

The RCU is PCI-aware and can be used to configure PCI expansion cards. Configuration information for PCI expansion cards is contained within the card, so no additional .cfg file is required. You should run the RCU *after* installing or moving a PCI expansion card to keep the system's database of available resources accurate.

How to Run the RCU

The RCU is included on the *Dell OpenManage Server Assistant* CD shipped with your system.

You can run the RCU directly from the CD or from a diskette that you create using the CD's main menu. Dell recommends that you run the RCU from a diskette because it is not compatible with all operating systems. Also, using a diskette to run the utility allows you to copy any system configuration changes to the diskette for safekeeping. Refer to the *Dell OpenManage Server Assistant* CD to create the RCU diskette.

PCI expansion cards do not require a configuration file. The PCI configuration utility in read-only memory (ROM) automatically uses the information maintained by the RCU to assign resources for PCI expansion cards.

When to Run the RCU

After the RCU has configured all of your PCI expansion cards, you can use the utility to *lock* the configuration of your PCI expansion cards so that they are always assigned the same resources. See "Locking and Unlocking Cards" found later in this chapter for details.



NOTE: If your system detects a card configuration problem during operation, you receive a warning message directing you to run the RCU to correct the problem.

Making Selections in the RCU

The RCU uses menus to guide you through the configuration process. The menus and their options are accessed through keyboard commands.

To make a menu selection, use the up- or down-arrow key to highlight the desired option, and then press <Enter>. In the **Help** menu or **Advanced** menu, you can also select an option by pressing the key that corresponds to the highlighted letter in the selection list.

To scroll up or down a screen, press the <Page Up> or <Page Down> key, respectively.

Using Online Instructions

The RCU has online instructions for each of its procedures. If you need help at any time, press <F1> to see a help screen that offers more details about the task you are doing.

Starting the RCU

If you are running the RCU from your hard-disk drive, remove any terminate-and-stay-resident (TSR) programs from memory before starting the utility. These programs take up space in system memory even when they are not running, thus reducing the

amount of memory available to the RCU. See the documentation that accompanied these programs for instructions on removing them from memory.

If you start the utility and there is not enough memory to run it, a message is displayed. If you receive such a message, run the utility from a diskette.

Follow these steps the first time you use the RCU.

To run the program from a diskette, insert into drive A the RCU diskette that you created from the *Dell OpenManage Server Assistant* CD. Then either turn on your computer or reboot it by pressing <Ctrl><Alt>.

1. *To run the program from your hard-disk drive*, switch to the **c:\rcu** subdirectory, type `sd` at the operating system prompt, and press <Enter>.

To run the program from the *Dell OpenManage Server Assistant* CD, restart the system from the CD and refer to the options on the CD's main menu to run the RCU.

2. When the **Welcome** screen appears, read the information on the screen and press <Enter>.

The **Main Menu** appears as follows:

Main Menu

```
Learn about configuring your computer
Configure computer
Set date
Set time
Maintain resource configuration diskette
Exit from this utility
```

The first option in the menu is already highlighted.

3. Press <Enter> to read the online overview of the RCU.

After reading the online overview, you are ready to use the program to configure your computer for any PCI expansion cards currently installed in your computer's expansion slots.

Main Menu

The following four sections describe each of the menu options in the **Main Menu** and the submenus for those options.

Learn About Configuring Your Computer

The **Learn About Configuring Your Computer** option presents an overview of the configuration process. As you finish reading a screen, press <Enter> to view the next screen. Press <F10> to return to the **Main Menu**.

Configure Computer

The **Configure Computer** option takes you through the configuration process step by step. Use this option the first time you configure your system and every time you change your hardware configuration through the RCU.

When you select **Configure Computer**, the following menu appears on the screen:

```
Steps in configuring your computer
Step 1: Important Resource Configuration Information
Step 2: Add or remove boards
Step 3: View or edit details
Step 4: Examine switches or print report
Step 5: Save and exit
```

Step 1: Important Resource Configuration Information

The **Step 1: Important Resource Configuration Information** option uses seven information screens to explain the configuration process. After reading the first screen, press <Enter> to see the next one. When you have finished reading all seven screens, press <Esc> to return to the **Steps in Configuring Your Computer** menu.

To review the information screens at any time while you are in the RCU, press <F1> and select **Resource Configuration** from the **Help** menu.

Step 2: Add or Remove Boards

This step is not used on PCI-only systems.

Step 3: View or Edit Details

The RCU lets you set a variety of system options through the **.sci** file. Through this file, you can notify the system of changes to your hardware and memory configuration, manage input/output (I/O) ports, and set other system operating parameters.

Some of the categories do not offer options, but reflect installed hardware detected by the system. These items are displayed for your information only; you cannot change them through the utility.

Display the list of system board options as follows:

1. Start the RCU as described in "Starting the RCU" found earlier in this chapter.
2. At the **Main Menu**, select **Configure Computer**.
3. At the **Steps in Configuring Your Computer** menu, select **Step 3: View or Edit Details**.

A list of system board options appears on the screen. Figure 5-1 shows settings typical for your system.



*NOTE: Whenever you add an expansion card to the computer, its presence is reflected by changes to the **System Board Options** screen.*

To select a category on the list of system board options, press the up- or down-arrow key to highlight the category and press <Enter>. A pop-up menu appears, listing the options for that category. To select an option, press the up- or down-arrow key to highlight the option and press <Enter>.



NOTES: Several system board categories allow you to edit such resources as memory address, I/O ports, interrupt requests (IRQ), and direct memory access (DMA) channels. It may be necessary to edit these resources to resolve a configuration conflict. To view the resource screen for any device, highlight the option and press <F6>.

The edit resources feature is intended for users who are technically knowledgeable. Do not change resource settings from their defaults if you do not understand how such a change will affect system performance.

*While in the **Step 3: View or Edit Details** menu, you can press <F7> to enter the **Advanced** menu. See "Advanced Menu" found later in this chapter for more information.*

When you have finished making changes, save the new system configuration information and exit the utility as follows:

1. Press <F10>, and select **Step 5: Save and Exit from the Steps in Configuring Your Computer** menu.
2. Select **Save the Configuration and Restart the Computer** from the menu that appears.

System - Dell System PowerEdge 4350	
RS-232 COM Port 1	IRQ 4 PORT 3F8h-3FFh
RS-232 COM Port 2	IRQ 3 PORT 2F8h-2FFh
Parallel Port	IRQ 7 PORT 378h-37Fh
Floppy Controller	Enabled
Mouse Controller	Enabled
Embedded - Adaptec AIC-7890 SCSI Ctrlr PCI Function 1	Enabled
Embedded - Adaptec AIC-7860 SCSI Ctrlr PCI Function 1	Enabled
Embedded - PCI VGA Controller PCI Function 1	Enabled
Standard VGA Resources	Enabled

Figure 5-1. View or Edit Details Screen (Example)

Step 4: Examine Switches or Print Report

The **Step 4: Examine Switches or Print Report** option lists the required switch and jumper settings for each expansion card in your computer. To view the settings, highlight the card and press <Enter>. Press <F7> to make a copy of or print the settings. If your computer is attached to a printer, you can print out the information or copy it to a file.

Step 5: Save and Exit

The **Step 5: Save and Exit** option allows you to save or cancel the configuration changes you have made. When you select this option, follow the directions on the menu that appears.

If you save your changes, the utility saves the new configuration in your system's NVRAM and in a file on your RCU diskette. Then, the utility automatically reboots your system.

If you cancel your changes, you can remain in the utility to make other changes or exit the utility without saving any changes.

Set Date

Set date allows you to set or change the computer date. Type the new date and press <Enter> to store it or <Esc> to cancel the change. The format is mm-dd-yyyy.

Set Time

Set time allows you to set or change the computer time. Type the new time and press <Enter> to store it or <Esc> to cancel the change. The format is hh:mm:ss.

Maintain Resource Configuration Diskette

Using the **Maintain Resource Configuration Diskette** option, you can create a backup copy of the system configuration information (.sci) file or use a previously saved .sci file to reconfigure your system or to identically configure many other systems. You can also copy, update, or delete .sci or .cfg files from your RCU diskette or the configuration diskette(s) for any hardware option.

Exit From This Utility

The **Exit From This Utility** option allows you to exit from the RCU and reboot your computer system.

Advanced Menu

The **Advanced** menu lets you lock or unlock cards in a configuration, view detailed information about the system, and maintain .sci files.

To see the **Advanced** menu, press <F7> while in the **Step 3: View or Edit Details** menu. The following menu appears:

Advanced menu
Lock/unlock boards
View additional system information menu
Set verification mode menu
Maintain SCI files menu

Highlight the menu category you want, and press <Enter>. Then follow the online instructions.

The following subsections describe each category.

Lock/Unlock Boards

When you *lock* an expansion card, the RCU cannot change the resources allocated to that card. *Unlocking* the card allows the system to change the resources automatically as new cards are added. The default for the **Lock/Unlock Boards** category is **Unlocked**. Dell recommends that you keep your cards unlocked so that the RCU can do its job properly.



NOTE: If changes are made to the hardware or System Setup configuration, locks may not be maintained.

View Additional System Information Menu

The RCU contains detailed information about the system board and the used and available resources. The options for the **View Additional System Information Menu** category are:

- **Board Specifications**
- **System Specifications**
- **Used Resources**
- **Available Resources**

The **Used Resources** and **Available Resources** options contain detailed information about resources such as IRQs, DMA channels, and I/O ports, which may be useful if you need to resolve a resource conflict.

Set Verification Mode Menu

The settings for the **Set Verification Mode Menu** category are **Automatic** (the default) and **Manual**. When this category is set to **Automatic**, the RCU automatically checks for resource conflicts and tries to resolve them. Unless you are technically knowledgeable, leave this category set to **Automatic**.

Maintain SCI Files Menu

Each time you use the RCU to configure your system, the system configuration information is saved in a **.sci** file and in system memory. You should save the system configuration information to a backup file that can be used to restore the information if the **.sci** file is damaged or lost. The options for the **Maintain SCI Files Menu** category are **Open** (the default) and **Save As**.

The **Open** option creates a backup file that overwrites the existing configuration. The **Save As** option allows you to select the filename under which you want the **.sci** file saved.

Resolving Resource Conflicts

The RCU automatically resolves resource conflicts between two PCI expansion cards. It is extremely unusual for the RCU to fail in resolving a resource conflict between two PCI expansion cards. If the RCU fails to resolve the conflict, see Chapter 12, "Getting Help," in your *Installation and Troubleshooting Guide* for information on obtaining technical assistance. If the **Set Verification Mode** menu category is set to **Automatic**, the RCU tries to resolve the conflict. If the utility cannot resolve the conflict, some devices installed in the system are deactivated and the following message is displayed:

Caution

The last board added caused an un-resolvable conflict in your computer's configuration. This board has a 'De-activated' status. You must remove this board or the one(s) it is in conflict with in order to save a correct configuration.

If the caution message appears, press <Enter> to display a list of all cards installed in your computer. The deactivated card is enclosed by < > symbols.

You can remove the card(s) with which it is in conflict, or change the resources on one or more cards. See "Removing an Expansion Card" in Chapter 8 of the *Installation and Troubleshooting Guide*.

If you remove the card(s) with which the new card is in conflict, or if you want to change the resources of one or more cards, use the procedure described in the next subsection.



NOTE: Locked cards may cause resource conflicts.

To unlock a card, use the following procedure:

1. Press <F7> in the **Step 3: View or Edit Details** menu (from the **Steps in Configuring Your Computer** menu).
2. Select **Lock/Unlock Boards** and press <Enter>.
3. Select the card(s) you want to unlock, and press <Enter>.
4. Press <F10> to exit the **Advanced** menu.

Removing a Card that Conflicts With the Card You Just Installed

If there is a resource conflict between two ISA expansion cards and you want to remove the card that conflicts with the one you just installed, use the following procedure:

1. From the **Steps in Configuring Your Computer** menu, select **Step 2: Add or Remove Boards** and press <Enter>.

From the list of expansion slots and cards, select the card in conflict with the one installed, and press . When the utility asks you to confirm your command, press <Enter>. Then, press <Esc> to return to the **Steps in Configuring Your Computer** menu.

2. Select **Step 5: Save and Exit**, and press <Enter>.
3. Select **Save the Configuration and Restart the Computer**, and press <Enter>.

The system reboots with the new system configuration information.

4. If you deleted an expansion-card configuration file from the previously saved system configuration information, remove the card from your computer.

For information on removing the expansion card, see "Removing an Expansion Card" in Chapter 8 of the *Installation and Troubleshooting Guide*.



APPENDIX A

Technical Specifications

Table A-1. Technical Specifications

Microprocessor	
Microprocessor types	one or two Intel Pentium II processors with an internal operating frequency of 350, 400, or 450 MHz and an external bus speed of 100 MHz
Internal cache	32-KB L1 cache; 512-KB L2 cache
Math coprocessor	internal to microprocessor
Expansion Bus	
Bus type	one primary PCI 32-bit bus; one secondary PCI bus and one ISA bus
Expansion slots	six 32-bit PCI slots, and two shared ISA slots
Memory	
DIMM sockets	four 168-pin sockets
DIMM capacities	64- and 128-MB unbuffered SDRAM DIMMs, or 256- or 512-MB registered ECC SDRAM DIMMS rated for 100-MHz operation.
Standard RAM (minimum).	64 MB
Maximum RAM	2 GB
External cache	none

NOTE: For the full name of an abbreviation or acronym used in this table, see the Glossary.

Table A-1. Technical Specifications (continued)

Drives	
Diskette drive	one 3.5-inch, 1.44-MB diskette drive included with standard system
SCSI hard-disk drives	formatted capacities from 4 GB to 9 GB (1-inch drives only)
SCSI devices	built-in Ultra2/LVD SCSI-3 host adapter supporting up to three 1-inch SCSI hard-disk drives in internal bays; built-in Ultra/Narrow SCSI-3 host adapter supporting the internal CD-ROM drive.
CD-ROM drive.	one SCSI CD-ROM drive included with standard system
Ports	
Externally accessible:	
Serial	two 9-pin connectors
Parallel (bidirectional)	one 25-pin connector
Video	one 15-pin connector
PS/2-style keyboard	6-pin mini-DIN
PS/2-compatible mouse.	6-pin mini-DIN
Server management bus daisy-chain connectors.	two modular 8-pin connectors
Internally accessible:	
Ultra2/LVD SCSI-3 controller	68-pin connector
Ultra/Narrow SCSI-3 controller	50-pin connector
Diskette drive.	34-pin connector
Storage-system server management bus connector	6-pin header connector
Video	
Video type	ATI Rage Pro AGP video controller; VGA connector
Video memory (standard)	2 MB

NOTE: For the full name of an abbreviation or acronym used in this table, see the Glossary.

Table A-1. Technical Specifications (continued)

Power	
AC power supply:	
Output wattage	275 W (DC) per supply (2 or 3 supplies)
Input voltage.	115 VAC at 60 Hz/230 VAC at 50 Hz
System battery	CR2032 3.0-V lithium coin cell

Physical	
Height (4U rack height))	17.3 cm (6.81 inches)
Width	43.4 cm (17.07 inches)
Depth	74.5 cm (29.32 inches)
Weight (maximum configuration)	34 kg (75 lb)

Environmental	
Temperature:	
Operating	10° to 35°C (50° to 95°F)
Storage	–40° to 65°C (–40° to 149°F)
Relative humidity:	
Operating	8% to 80% (noncondensing)
Storage	5% to 95% (noncondensing)
Maximum vibration:	
Operating	0.25 G at 3 to 200 Hz for 15 min
Storage	0.5 G at 3 to 200 Hz for 15 min
Maximum shock:	
Operating	6 shock pulses in the positive and negative x, y, and z axes at 50 G for 2 ms
Storage	6 shock pulses in the positive and negative x, y, and z axes at 92 G for 2 ms
Altitude:	
Operating	–16 to 3048 m (–50 to 10,000 ft)
Storage	–16 to 10,600 m (–50 to 35,000 ft)

NOTE: For the full name of an abbreviation or acronym used in this table, see the Glossary.



APPENDIX B

I/O Ports and Connectors

The input/output (I/O) ports and connectors on the back panel of the system are the gateways through which the computer system communicates with external devices, such as a keyboard, mouse, printer, and monitor. Figure B-1 identifies the I/O ports and connectors for your system.

Serial and Parallel Ports

The two built-in serial ports use 9-pin D-subminiature connectors on the back panel. These ports support devices such as external modems, printers, plotters, and mice that require serial data transmission (the transmission of data one bit at a time over one line).

Most software uses the term *COM* (for communications) plus a number to designate a serial port (for example, COM1 or COM2). The default designations of your system's built-in serial ports are COM1 and COM2. COM1 is the right connector; COM2 is the left connector.

The built-in parallel port uses a 25-pin D-subminiature connector on the system's back panel. This I/O port sends data in parallel format (where eight data bits, or one byte, are sent simultaneously over eight separate lines in a single cable). The parallel port is used primarily for printers.

Most software uses the term *LPT* (for line printer) plus a number to designate a parallel port (for example, LPT1). The default designation of the system's built-in parallel port is LPT1.

Port designations are used, for example, in software installation procedures that include a step in which you identify the port to which a printer is attached, thus telling the software where to send its output. (An incorrect designation prevents the printer from printing or causes scrambled print.)

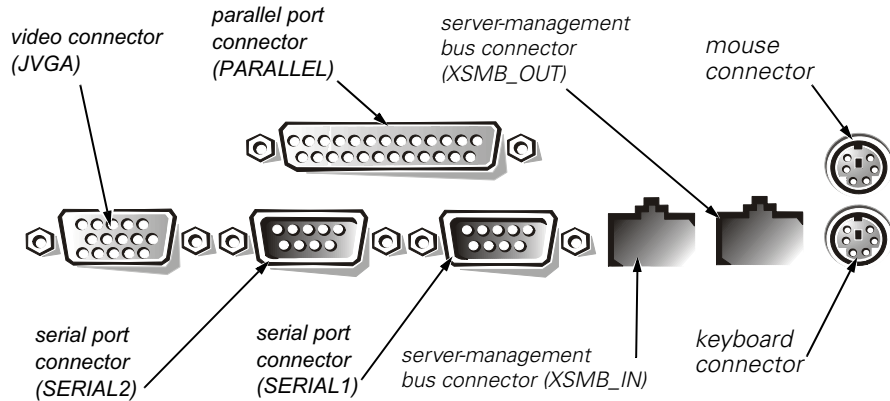

Figure B-1. I/O Ports and Connectors

Adding an Expansion Card Containing Serial or Parallel Ports

The system has an autoconfiguration capability for the serial ports. This feature lets you add an expansion card containing a serial port that has the same designation as one of the built-in ports, without having to reconfigure the card. When the system detects the duplicate serial port on the expansion card, it *remaps* (reassigns) the built-in port to the next available port designation.

Both the new and the remapped COM ports share the same interrupt request (IRQ) setting, as follows:

COM1, COM3: IRQ4 (shared setting)
 COM2, COM4: IRQ3 (shared setting)

These COM ports have the following I/O address settings:

COM1: 3F8h
 COM2: 2F8h
 COM3: 3E8h
 COM4: 2E8h

For example, if you add an internal modem card with a port configured as COM1, the system then sees logical COM1 as the address on the modem card. It automatically remaps the built-in serial port that was designated as COM1 to COM3, which shares the COM1 IRQ setting. (Note that when you have two COM ports sharing an IRQ setting, you can use either port as necessary *but you may not be able to use them both at the same time*.) If you install one or more expansion cards with serial ports designated as COM1 and COM3, the corresponding built-in serial port is disabled.

Before adding a card that remaps the COM ports, check the documentation that accompanied your software to make sure that the software can be mapped to the new COM port designation.

To avoid autoconfiguration, you may be able to reset jumpers on the expansion card so that the card's port designation changes to the next available COM number, leaving the designation for the built-in port as is. Alternatively, you can disable the built-in ports through the System Setup program. The documentation for your expansion card should provide the card's default I/O address and allowable IRQ settings. It should also provide instructions for readdressing the port and changing the IRQ setting, if necessary.

The built-in parallel port has autoconfiguration capability through the System Setup program; that is, if you set the parallel port to its automatic configuration and add an expansion card containing a port configured as LPT1 (IRQ7, I/O address 378h), the system automatically remaps the built-in parallel port to its secondary address (IRQ5, I/O address 278h). If the secondary port address is already being used, the built-in parallel port is turned off.

For general information on how your operating system handles serial and parallel ports, and for more detailed command procedures, see your operating system documentation.

Serial Port Connectors

If you reconfigure your hardware, you may need pin number and signal information for the serial port connectors. Figure B-2 illustrates the pin numbers for the serial port connectors, and Table B-1 lists and defines the pin assignments and interface signals for the serial port connectors.

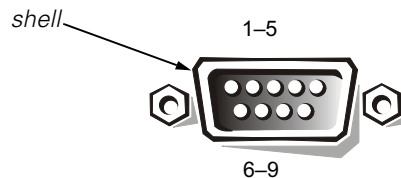

Figure B-2. Pin Numbers for the Serial Port Connectors

Table B-1. Pin Assignments for the Serial Port Connectors

Pin	Signal	I/O	Definition
1	DCD	I	Data carrier detect
2	SIN	I	Serial input
3	SOUT	O	Serial output
4	DTR	O	Data terminal ready
5	GND	N/A	Signal ground
6	DSR	I	Data set ready
7	RTS	O	Request to send
8	CTS	I	Clear to send
9	RI	I	Ring indicator
Shell	N/A	N/A	Chassis ground

Parallel Port Connector

If you reconfigure your hardware, you may need pin number and signal information for the parallel port connector. Figure B-3 illustrates the pin numbers for the parallel port connector, and Table B-2 lists and defines the pin assignments and interface signals for the parallel port connector.

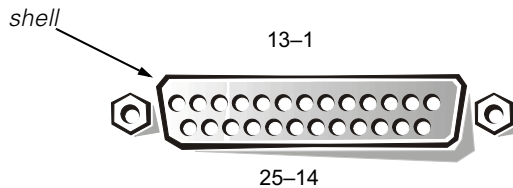

Figure B-3. Pin Numbers for the Parallel Port Connector

Table B-2. Pin Assignments for the Parallel Port Connector

Pin	Signal	I/O	Definition
1	STB#	I/O	Strobe
2	PD0	I/O	Printer data bit 0
3	PD1	I/O	Printer data bit 1
4	PD2	I/O	Printer data bit 2
5	PD3	I/O	Printer data bit 3
6	PD4	I/O	Printer data bit 4
7	PD5	I/O	Printer data bit 5
8	PD6	I/O	Printer data bit 6
9	PD7	I/O	Printer data bit 7
10	ACK#	I	Acknowledge
11	BUSY	I	Busy
12	PE	I	Paper end
13	SLCT	I	Select
14	AFD#	O	Automatic feed
15	ERR#	I	Error
16	INIT#	O	Initialize printer
17	SLIN#	O	Select in
18–25	GND	N/A	Signal ground

Keyboard and Mouse Connectors

The system uses a Personal System/2 (PS/2)-style keyboard and supports a PS/2-compatible mouse. Cables from both devices attach to 6-pin, miniature *Deutsche Industrie Norm* (DIN) connectors on the back panel of your system. The keyboard connector is on the bottom; the mouse connector is on the top.

A PS/2-compatible mouse works identically to an industry-standard serial mouse or bus mouse except that it has its own dedicated connector, which frees up both serial ports and does not require an expansion card. Circuitry inside the mouse detects the movement of a small ball and relays the direction to the system.

Mouse driver software can give the mouse priority with the microprocessor by issuing IRQ12 whenever new mouse movement is detected. The driver software also passes along the mouse data to the application that is in control.

Keyboard Connector

If you reconfigure your hardware, you may need pin number and signal information for the keyboard connector. Figure B-4 illustrates the pin numbers for the keyboard connector, and Table B-3 lists and defines the pin assignments and interface signals for the keyboard connector.

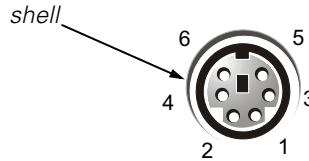

Figure B-4. Pin Numbers for the Keyboard Connector

Table B-3. Pin Assignments for the Keyboard Connector

Pin	Signal	I/O	Definition
1	KBDATA	I/O	Keyboard data
2	NC	N/A	No connection
3	GND	N/A	Signal ground
4	FVcc	N/A	Fused supply voltage
5	KBCLK	I/O	Keyboard clock
6	NC	N/A	No connection
Shell	N/A	N/A	Chassis ground

Mouse Connector

If you reconfigure your hardware, you may need pin number and signal information for the mouse connector. Figure B-5 illustrates the pin numbers for the mouse connector, and Table B-4 lists and defines the pin assignments and interface signals for the mouse connector.

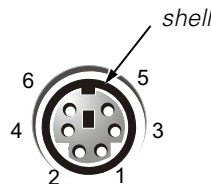

Figure B-5. Pin Numbers for the Mouse Connector

Table B-4. Pin Assignments for the Mouse Connector

Pin	Signal	I/O	Definition
1	MFDATA	I/O	Mouse data
2	NC	N/A	No connection
3	GND	N/A	Signal ground
4	FVcc	N/A	Fused supply voltage
5	MFCLK	I/O	Mouse clock
6	NC	N/A	No connection
Shell	N/A	N/A	Chassis ground

Video Connector

The system uses a 15-pin high-density D-subminiature connector on the back panel for attaching a video graphics array (VGA)-compatible monitor to your system. The video circuitry on the system board synchronizes the signals that drive the red, green, and blue electron guns in the monitor.



NOTE: Installing a video card automatically disables the system's built-in video subsystem.

If you reconfigure your hardware, you may need pin number and signal information for the video connector. Figure B-6 illustrates the pin numbers for the video connector, and Table B-5 lists and defines the pin assignments and interface signals for the video connector.

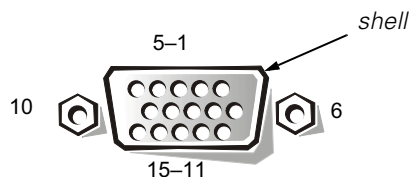

Figure B-6. Pin Numbers for the Video Connector

Table B-5. Pin Assignments for the Video Connector

Pin	Signal	I/O	Definition
1	RED	O	Red video
2	GREEN	O	Green video
3	BLUE	O	Blue video
4	NC	N/A	No connection
5–8, 10	GND	N/A	Signal ground
9	VCC	N/A	Vcc
11	NC	N/A	No connection
12	DDC data out	O	Monitor detect data
13	HSYNC	O	Horizontal synchronization
14	VSYNC	O	Vertical synchronization
15	DDC clock out	O	Monitor detect clock
Shell	N/A	N/A	Chassis ground

Server-Management Bus Connectors

The server-management bus (SMB) connectors (XSMB_IN and XSMB_OUT) are used to daisy-chain servers together so that server management information can be shared between the servers. Figure B-7 illustrates the pin numbers for the SMB connectors, and Figure B-6 lists and defines the pin assignments and interface signals for the SMB connectors.

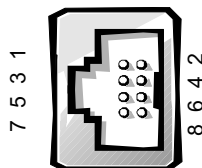

Figure B-7. Pin Numbers for the Server-Management Bus Connectors

Table B-6. Pin Assignments for the Server-Management Bus Connectors

Pin	Signal	I/O	Definition
1	RS-485 A	I/O	Noninverting receiver input and noninverting driver output
2	RS-485 B	I/O	Inverting receiver input and inverting driver output
3	NC	N/A	No connection
4	NC	N/A	No connection
5	NC	N/A	No connection
6	NC	N/A	No connection
7	NC	N/A	No connection
8	NC	N/A	No connection



APPENDIX C

Maintaining the System

Proper use of preventive maintenance procedures can keep the system in top operating condition and minimize the need for costly, time-consuming service procedures. This appendix contains maintenance procedures that you should perform regularly.

Data Preservation

Everyone inadvertently deletes files at one time or another. Also, hard-disk drives can fail after extended use, so it is not a question of *whether* you will eventually lose data, but *when*. To avoid such loss of data, you should regularly make backup copies of all hard-disk drive files. Frequent, regular backups are a must for anyone using a hard-disk drive.

Scheduling Backups

The frequency with which backups should be made depends on the amount of storage space on a hard-disk drive and the volatility of the data contained on the drive. Heavily used systems require more frequent backups than systems in which files are seldom changed.

Dell recommends that you back up the hard-disk drive at least once a week, with a daily backup of those files known to have been changed. Following these guidelines ensures the loss of no more than a day's work in the event of a hard-disk drive failure or if you inadvertently delete one or more important files.

As further insurance against data losses, you should keep duplicate copies of the weekly and monthly backups at an off-site location. Doing this ensures that you lose no more than a week's work, even if one of the on-site backups becomes corrupted.

Backup Devices

Tape drives are fast, convenient, and reliable devices that can back up data at rates of up to 1.5 megabytes per second (MB/sec) (sustained, without data compression) and can often run unattended. Dell offers tape drives with storage capacities in the range of 20 to 70 gigabytes (GB) (when available) per tape cartridge and recommends these drives and their associated backup software for use as system backup devices.

As a last resort, you can back up a hard-disk drive's contents on diskettes, a method that is both time-consuming and prone to human error. Also, backing up a full 4-GB hard-disk drive requires approximately 277 diskettes (when using 1.44-MB diskettes), 334 diskettes (when using 1.2-MB diskettes), or 139 diskettes (when using 2.88-MB diskettes). Therefore, if it is absolutely necessary to use diskettes as backup devices, any unwanted hard-disk drive files should be deleted before a backup procedure is started.

Recovering Data

Some hard-disk drive failures are recoverable. In these cases you may be able to recover all lost data if the proper utility software is available. Even losses such as accidentally deleted files or accidental reformatting of a hard-disk drive can be reversed with these utilities.

If the system is running MS-DOS, many apparent data loss problems are due to corruption or erasure of the hard-disk drive's master boot record (MBR), MS-DOS boot sector, or file allocation table (FAT). That is, accidental deletion of files or accidental reformatting of the hard-disk drive alters the MS-DOS boot sector, the FAT, and the root directory.

However, such accidents do not actually erase the contents of the hard-disk drive files until new data is written to the sectors containing these files. With software such as the Norton Utilities, Mace Utilities, or PC-Tools Deluxe, the data stored in these areas can often be restored, meaning that you can recover most, if not all, of the data.

Unlike using the **format** command on a hard-disk drive, using **format** on a diskette completely erases all the data on the diskette unless you use the diskette **format** program included in the Mace Utilities.

For a complete description of data recovery procedures and the software needed to perform them, see *The Paul Mace Guide to Data Recovery*, published by Brady.

Cleaning System Components

The fan assembly cools the system by drawing air in through various openings in the system and blowing it out the back. However, the fan also draws dust and other particles into the system, causing contaminant buildup, which results in an increase in the system's internal temperature and interferes with the operation of various system components.

To avoid these conditions, Dell recommends keeping your work environment clean to reduce the amount of dust and dirt around the system, thereby reducing the amount of contaminants drawn into the system by the power supply fan. In particular, you should keep the exterior of your system and monitor clean, and you should use a commercially available diskette-drive head-cleaning kit to remove contaminants inside your diskette drives.

Recommended Tools and Accessories

Dell recommends that you use the following tools and accessories when you clean the system:

- *A wrist grounding strap*— The proper use of a wrist grounding strap reduces the effect of electrostatic discharge (ESD), which can damage certain system components. To use a wrist grounding strap, place the strap around your wrist and attach the other end of the strap to an unpainted metal surface in the chassis, such as the power supply bracket, that is connected to chassis ground.
- *A liquid dishwashing detergent* — Use a mixture of one part liquid dishwashing detergent and three parts water to clean the exterior of the system, monitor, and keyboard. You can also add fabric softener to produce an antistatic solution that prevents dust from being attracted to the monitor screen.
- *A soft, lint-free cleaning cloth*— Moisten the cleaning cloth with the dishwashing detergent solution to clean the exterior of the system.
- *A nonabrasive diskette-drive head-cleaning kit*— Dell recommends that you use a kit that contains pretreated diskettes in individually sealed packages. These kits ensure that the cleaning solution is applied evenly over the entire diskette-drive head surface, and they prevent contamination of the heads by exposure to foreign substances.
- *A small vacuum cleaner with a brush attachment*— Use the vacuum cleaner to remove dust and dirt from the exterior of the system and keyboard.

Cleaning the System, Monitor, and Keyboard Exteriors

A conventional monitor or keyboard cover minimizes the accumulation of dust and other debris inside the monitor and keyboard when they are not in use. Also, commercially available keyboard membrane covers make it possible to use the keyboard while providing protection against foreign particles.

However, regardless of any protective covers, the monitor and keyboard must be cleaned occasionally. To clean the exterior of the system, monitor, and keyboard, follow these steps:

1. Turn off the system, monitor, and any other attached peripherals, and disconnect them from their power sources.
2. Use a vacuum cleaner to remove any dust from the slots and holes on the system and between the keys on the keyboard.
3. Moisten a soft cleaning cloth with a solution of three parts water and one part liquid dishwashing detergent.

Do not soak the cloth in the solution; you must not let the solution drip inside the system or keyboard.

4. Use the moistened cloth to wipe the system cover, the keyboard, and the exterior of the monitor, including the screen.

Cleaning Drives

You can clean the heads of your diskette drives by using a commercially available diskette-drive head-cleaning kit. These kits include diskettes pretreated with a chemical solution to nonabrasively remove contaminants that accumulate on the drive heads during normal operation.

If the kit does not contain instructions, insert one of the pretreated diskettes into a diskette drive and turn on the system. After 20 or 30 seconds, remove the diskette from the drive. Repeat this procedure for each diskette drive in the system.



CAUTION: Do not attempt to clean drive heads with a swab. You may accidentally misalign the heads, rendering the drive inoperable.

Environmental Factors

This section discusses various environmental factors that can adversely affect system performance and longevity.

Temperature

Temperature extremes can cause a variety of problems, including premature aging and failure of chips or mechanical failure of devices. Extreme temperature fluctuations can cause chips to become loose in their sockets and can cause expansion and contraction of disk drive platters, resulting in read or write data errors. When you perform a low-level format operation on a hard-disk drive, it is important to ensure that the drive's surrounding temperature is at or near the temperature at which the drive will be operated. Failure to do so can result in relocation of the tracks on the disk platters.

To minimize the negative effects of temperature on system performance, follow these guidelines:

- Ensure that the system is operated in an environment no colder than 10° Celsius (C) (50° Fahrenheit [F]) or hotter than 35°C (95°F).
- Ensure that the system has adequate ventilation. Do not place it within a closed-in wall unit or on top of cloth material, which can act as insulation. Do not place it where it will receive direct sunlight, particularly in the afternoon. Do not place it next to a heat source of any kind, including heating vents during winter.

Adequate ventilation is particularly important at high altitudes. System performance may not be optimum when the system is operating at high temperatures as well as high altitudes.

- Make sure that all slots and openings on the system remain unobstructed, especially the fan vent on the back of the system.
- Clean the system at regular intervals to avoid any buildup of dust and debris, which can cause a system to overheat.

- If the system has been exposed to abnormally cold temperatures, allow a two-hour warm-up period to bring it up to normal operating temperature before turning it on. Failure to do so may cause damage to internal components, particularly the hard-disk drive.
- If intermittent system failures are noticed, try reseating any socketed chips, which might have become loose due to temperature fluctuations.

Humidity

High-humidity conditions can cause moisture migration and penetration into the system. This moisture can cause corrosion of internal components and degradation of properties such as electrical resistance, thermal conductivity, physical strength, and size. Extreme moisture buildup inside the system can result in electrical shorts, which can cause serious damage to the system.

Each Dell system is rated to operate at 8 to 80 percent relative humidity, with a humidity gradation of 10 percent per hour. In storage, a Dell system can withstand from 5 to 95 percent relative humidity.

Buildings in which climate is controlled by air-conditioning in the warmer months and by heat during the colder months usually maintain an acceptable level of humidity for system equipment. However, if a system is located in an unusually humid location, a dehumidifier can be used to maintain the humidity within an acceptable range.

Altitude

Operating a system at high altitude (low pressure) reduces the efficiency of forced and convection cooling and can result in electrical problems related to arcing and corona effects. This condition can also cause sealed components with internal pressure, such as electrolytic capacitors, to fail or perform at reduced efficiency.

Each Dell system is rated to operate at altitudes from –16 to 3048 meters (m) (–50 to 10,000 feet [ft]) and can be stored at altitudes of –16 to 10,600 m (–50 to 35,000 ft).

Dust and Particles

A clean operating environment can greatly reduce the negative effects of dust and other particles, which act as insulators and interfere with the operation of a system's mechanical components. Also, in addition to regular cleaning, you should follow these guidelines to deter contamination of the system equipment:

- Do not permit smoking anywhere near the system.
- Do not permit food or drink near the system.
- Use dust covers when the system is not in use.
- Keep all diskettes in a closed diskette box when not in use.
- Close windows and outside doors to keep out airborne particles.

Corrosion

The oil from a person's fingers or prolonged exposure to high temperature or humidity can corrode the gold-plated edge connectors and pin connectors on various devices in the system. This corrosion on system connectors is a gradual process that can eventually lead to intermittent failures of electrical circuits.

To prevent corrosion, you should avoid touching contacts on boards and cards. Protecting the system from corrosive elements is especially important in moist and salty environments, which tend to promote corrosion. Also, as a further deterrent to corrosion, the system should not be used in extreme temperatures, as explained in "Temperature" found earlier in this appendix.

ESD

ESD results from the buildup of static electricity on the human body and certain other objects. This static electricity is often produced by simple movements such as walking across a carpet. ESD is a discharge of a static electrical charge, that occurs when a person whose body contains such a charge touches a component in the system. This static discharge can cause components, especially chips, to fail. ESD is a problem particularly in dry environments where the relative humidity is below 50 percent. To reduce the effects of ESD, you should observe the following guidelines:

- When working inside the system, wear a wrist grounding strap. If a wrist grounding strap is unavailable, touch an unpainted metal surface on the chassis periodically to neutralize any static charge.
- If at all possible, stand on a concrete floor while working inside the system.
- Use an antistatic floor mat when working inside the system.
- If it is necessary to work in a carpeted area, spray the carpet with an antistatic spray and allow it to dry before beginning to work inside the system.
- Keep components in their antistatic packaging until they are installed.
- Avoid wearing clothing made of wool or synthetic materials.

Electromagnetic and Radio Frequency Interference

Electromagnetic interference (EMI) and radio frequency interference (RFI) from a system can adversely affect devices such as radio and television (TV) receivers operating near the system. Radio frequencies emanating from a system can also interfere with cordless and low-power telephones. Conversely, RFI from high-power telephones can cause spurious characters to appear on the system's monitor screen.

RFI is defined as any EMI with a frequency above 10 kilohertz (kHz). This type of interference can travel from the system to other devices through the alternating current (AC) power cable and power source or through the air like transmitted radio waves. The Federal Communications Commission (FCC) publishes specific regulations to limit the amount of EMI and RFI emitted by computing equipment. Each Dell system meets these FCC regulations.

To reduce the possibility of EMI and RFI, follow these guidelines:

- Operate the system only with the system cover installed.
- Ensure that all expansion slots are covered either by a card-mounting bracket or by a metal filler bracket and that all drive bays have a drive and/or a metal insert installed. These brackets and metal inserts are available from Dell.
- Ensure that the screws on all peripheral cable connectors are securely fastened to their corresponding connectors on the back of the system.
- Always use shielded cables with metal connector shells for attaching peripherals to the system.

To prevent the possibility of RFI from a system affecting TV reception, follow these guidelines:

- Keep any TV set at least 6 ft away from the system.
- Use cable TV when possible.
- Use a directional outdoor TV antenna.
- Attach line filters to the TV set.
- Use 75-ohm coaxial cable for the TV set rather than twin-lead antenna wire.
- If interference occurs, rotate the system or the TV set 90 degrees.

Magnetism

Because they store data magnetically, diskettes and hard-disk drives are extremely susceptible to the effects of magnetism. Diskettes should never be stored near magnetic sources such as the following:

- Monitors
- TV sets
- Printers
- Telephones with real bells
- Fluorescent lights

Shock and Vibration

Excessive shock can damage the function, external appearance, and physical structure of a system. Each Dell system has been designed to operate properly even after withstanding a minimum of six consecutively executed shock pulses in the positive and negative x, y, and z axes (one pulse on each side of the system). Each shock pulse can measure up to 50 gravities (G) for up to 2 milliseconds (ms). In storage, the system can withstand shock pulses of 92 G for 2 ms.

Excessive vibration can cause the same problems as mentioned earlier for shock, as well as cause components to become loose in their sockets or connectors. Systems can be subject to significant vibration when being transported by vehicle or when operated in an environment with machinery that causes vibration.

Each Dell system, when operating, is designed to withstand 0.25 G (half-sine wave) at a sweep of 3 to 200 hertz (Hz) for 15 minutes. In storage, the system can withstand 0.5 G at 3 to 200 Hz for 15 minutes.

Power Source Interruptions

Systems are especially sensitive to variations in voltage supplied by the AC power source. Over-voltage, undervoltage, and transients (or *spikes*) can erase data from memory or even cause components to fail. To protect against these types of problems, power cables should always be properly grounded and one or both of the following methods should be used:

- Use one of the power protection devices described in the following section, “Power Protection Devices.”
- Place the system on a dedicated power circuit (rather than sharing a circuit with other heavy electrical equipment). In general, do not allow the system to share a circuit with any of the following:
 - Copier machines
 - Air conditioners
 - Vacuum cleaners
 - Space heaters
 - Power tools
 - Teletype machines
 - Adding machines
 - Laser printers
 - Facsimile machines
 - Any other motorized equipment

Besides these appliances, the greatest threat to a system’s supply of power are surges or blackouts caused by electrical storms. Whenever possible, turn off the system and any peripherals and unplug them from their power sources during thunderstorms.

If a blackout occurs—even a temporary one—while the system is turned on, turn off the system immediately and disconnect it from its power source. Leaving the system on may cause problems when the power is restored; all other appliances left on in the area can create large voltage spikes that can damage the system.

Power Protection Devices

A number of devices are available that protect against power problems, such as power surges, transients, and power failures. The following subsections describe some of these devices.

Surge Protectors

Surge protectors are available in a variety of types and usually provide a level of protection commensurate with the cost of the device. Surge protectors prevent voltage spikes, such as those caused during an electrical storm, from entering a system through the AC power source. Surge protectors, however, do not offer protection against brownouts, which occur when the voltage drops more than 20 percent below the normal AC line voltage level.

Line Conditioners

Line conditioners go beyond the overvoltage protection of surge protectors. Line conditioners keep a system's AC power source voltage at a fairly constant level and, therefore, can handle brownouts. Because of this added protection, line conditioners cost more than surge protectors—up to several hundred dollars. However, these devices cannot protect against a complete loss of power.

Uninterruptible Power Supplies

Uninterruptible power supply (UPS) systems offer the most complete protection against variations in power because they use battery power to keep the system running when AC power is lost. The battery is charged by the AC power while it is available, so once AC power is lost, the battery can provide power to the system for a limited amount of time—from 15 minutes to an hour or so—depending on the UPS system.

UPS systems range in price from a few hundred dollars to several thousand dollars, with the more expensive units allowing you to run larger systems for a longer period of time when AC power is lost. UPS systems that provide only 5 minutes of battery power let you conduct an orderly shutdown of the system, but are not intended to provide continued operation. Surge protectors should be used with all UPS systems, and the UPS system should be Underwriters Laboratories (UL) safety-approved.



APPENDIX D

Regulatory Notices

Electromagnetic interference (EMI) is any signal or emission, radiated in free space or conducted along power or signal leads, that endangers the functioning of a radio navigation or other safety service or seriously degrades, obstructs, or repeatedly interrupts a licensed radio communications service. Radio communications services include but are not limited to AM/FM commercial broadcast, television, cellular services, radar, air-traffic control, pager, and Personal Communication Services (PCS). These licensed services, along with unintentional radiators such as digital devices, including computer systems, contribute to the electromagnetic environment.

Electromagnetic compatibility (EMC) is the ability of items of electronic equipment to function properly together in the electronic environment. While this computer system has been designed and determined to be compliant with regulatory agency limits for EMI, there is no guarantee that interference will not occur in a particular installation. If this equipment does cause interference with radio communications services, which can be determined by turning the equipment off and on, you are encouraged to try to correct the interference by one or more of the following measures:

- Reorient the receiving antenna.
- Relocate the computer with respect to the receiver.
- Move the computer away from the receiver.
- Plug the computer into a different outlet so that the computer and the receiver are on different branch circuits.

If necessary, consult a Regulatory EMC representative of Dell Computer Corporation or an experienced radio/television technician for additional suggestions. You may find the *FCC Interference Handbook, 1986*, to be helpful. It is available from the U.S. Government Printing Office, Washington, DC 20402, Stock No. 004-000-00450-7 or on the World Wide Web at www.fcc.gov/Bureaus/Compliance/WWW/tvibook.html.

Dell computer systems are designed, tested, and classified for their intended electromagnetic environment. These electromagnetic environment classifications generally refer to the following harmonized definitions:

- Class A is for business or industrial environments.
- Class B is for residential environments.

Information Technology Equipment (ITE), including peripherals, expansion cards, printers, input/output (I/O) devices, monitors, and so on, that are integrated into or connected to the system should match the electromagnetic environment classification of the computer system.

A Notice About Shielded Signal Cables: Use only shielded cables for connecting peripherals to any Dell device to reduce the possibility of interference with radio communications services. Using shielded cables ensures that you maintain the appropriate EMC classification for the intended environment. For parallel printers, a cable is available from Dell Computer Corporation. If you prefer, you can order a cable from Dell Computer Corporation on the World Wide Web at <http://www.dell.com/products/dellware/index.htm>.

A Notice About Networked Computer Systems: Some Dell computer systems that are classified for Class B environments may include an onboard network interface controller (NIC). If your Class B system contains a NIC, it may be considered to be a Class A system at the time that the NIC is connected to a network. When the NIC is not connected to a network, your system is considered to be a Class B digital device.

Most Dell computer systems are classified for Class B environments. To determine the electromagnetic classification for your system or device, refer to the following sections specific for each regulatory agency. Each section provides country-specific EMC/EMI or product safety information.

FCC Notices (U.S. Only)

Most Dell computer systems are classified by the Federal Communications Commission (FCC) as Class B digital devices. However, the inclusion of certain options can change the rating of some configurations to Class A. To determine which classification applies to your computer system, examine all FCC registration labels located on the bottom or back panel of your computer, on card-mounting brackets, and on the cards themselves. If any one of the labels carries a Class A rating, your entire system is considered to be a Class A digital device. If *all* labels carry either the Class B rating distinguished by either an FCC ID number or the FCC logo, (FCC), your system is considered to be a Class B digital device.

Once you have determined your system's FCC classification, read the appropriate FCC notice. Note that FCC regulations provide that changes or modifications not expressly approved by Dell Computer Corporation could void your authority to operate this equipment.

This device complies with Part 15 of the FCC Rules. Operation is subject to the following two conditions:

- This device may not cause harmful interference.
- This device must accept any interference received, including interference that may cause undesired operation.

Class A

This equipment has been tested and found to comply with the limits for a Class A digital device pursuant to Part 15 of the FCC Rules. These limits are designed to provide reasonable protection against harmful interference when the equipment is operated in a commercial environment. This equipment generates, uses, and can radiate radio frequency energy and, if not installed and used in accordance with the manufacturer's instruction manual, may cause harmful interference with radio communications. Operation of this equipment in a residential area is likely to cause harmful interference, in which case you will be required to correct the interference at your own expense.

The following information is provided on the device or devices covered in this document in compliance with FCC regulations:

- Product name: Dell PowerEdge 4350
- Model number: STL
- Company name: Dell Computer Corporation
EMC Engineering Department
One Dell Way
Round Rock, Texas 78682 USA
512-338-4400

IC Notice (Canada Only)

Most Dell computer systems (and other Dell digital apparatus) are classified by the Industry Canada (IC) Interference-Causing Equipment Standard #3 (ICES-003) as Class B digital devices. To determine which classification (Class A or B) applies to your computer system (or other Dell digital apparatus), examine all registration labels located on the bottom or the back panel of your computer (or other digital apparatus). A statement in the form of "IC Class A ICES-3" or "IC Class B ICES-3" will be located on one of these labels. Note that Industry Canada regulations provide that changes or modifications not expressly approved by Dell Computer Corporation could void your authority to operate this equipment.

This Class B (or Class A, if so indicated on the registration label) digital apparatus meets the requirements of the Canadian Interference-Causing Equipment Regulations.

Cet appareil numérique de la Classe B (ou Classe A, si ainsi indiqué sur l'étiquette d'enregistrement) respecte toutes les exigences du Règlement sur le Matériel Brouilleur du Canada.

CE Notice (European Union)

Marking by the symbol **CE** indicates compliance of this Dell system to the EMC Directive and the Low Voltage Directive of the European Union. Such marking is indicative that this Dell system meets the following technical standards:

- EN 55022 — “Limits and Methods of Measurement of Radio Interference Characteristics of Information Technology Equipment.”
- EN 50082-1: 1992 — “Electromagnetic compatibility—Generic immunity standard Part 1: Residential, commercial, and light industry.”
- EN 60950 — “Safety of Information Technology Equipment.”



NOTE: EN 55022 emissions requirements provide for two classifications:

- *Class A is for typical commercial areas.*
- *Class B is for typical domestic areas.*



WARNING: This is a Class A product. In a domestic environment this product may cause radio interference in which case the user may be required to take adequate measures.

A “Declaration of Conformity” in accordance with the preceding directives and standards has been made and is on file at Dell Products Europe BV, Limerick, Ireland.

EN 55022 Compliance (Czech Republic Only)

This device belongs to Class B devices as described in EN 55022, unless it is specifically stated that it is a Class A device on the specification label. The following applies to devices in Class A of EN 55022 (radius of protection up to 30 meters). The user of the device is obliged to take all steps necessary to remove sources of interference to telecommunication or other devices.

Pokud není na typovém štítku počítače uvedeno, že spadá do třídy A podle EN 55022, spadá automaticky do třídy B podle EN 55022. Pro zařízení zařazená do třídy A (ochranné pásmo 30m) podle EN 55022 platí následující. Dojde-li k rušení telekomunikačních nebo jiných zařízení, je uživatel povinen provést taková opatření, aby rušení odstranil.

VCCI Notice (Japan Only)

Most Dell computer systems are classified by the Voluntary Control Council for Interference (VCCI) as Class B information technology equipment (ITE). However, the inclusion of certain options can change the rating of some configurations to Class A. ITE, including peripherals, expansion cards, printers, input/output (I/O) devices, monitors, and so on, integrated into or connected to the system, should match the electromagnetic environment classification (Class A or B) of the computer system.

To determine which classification applies to your computer system, examine the regulatory labels/markings (see Figures D-1 and D-2) located on the bottom or back panel of your computer. Once you have determined your system's VCCI classification, read the appropriate VCCI notice.

Class A ITE

この装置は、情報処理装置等電波障害自主規制協議会 (VCCI) の基準に基づくクラス A 情報技術装置です。この装置を家庭環境で使用すると電波妨害を引き起こすことがあります。この場合には使用者が適切な対策を講ずるよう要求されることがあります。

This is a Class A product based on the standard of the Voluntary Control Council for Interference (VCCI) for information technology equipment. If this equipment is used in a domestic environment, radio disturbance may arise. When such trouble occurs, the user may be required to take corrective actions.

VCCI-A

Figure D-1. VCCI Class A ITE Regulatory Mark

Class B ITE

この装置は、情報処理装置等電波障害自主規制協議会 (VCCI) の基準に基づくクラス B 情報技術装置です。この装置は家庭環境で使用することを目的としていますが、この装置がラジオやテレビジョン受信機に近接して使用させると、受信障害を引き起こすことがあります。取扱説明書に従って正しい取り扱いをして下さい。

This is a Class B product based on the standard of the Voluntary Control Council for Interference (VCCI) for information technology equipment. If this equipment is used near a radio or television receiver in a domestic environment, it may cause radio interference. Install and use the equipment according to the instruction manual.



Figure D-2. VCCI Class B ITE Regulatory Mark

MOC Notice (South Korea Only)

To determine which classification (Class A or B) applies to your computer system (or other Dell digital device), examine the South Korean Ministry of Communications (MOC) registration labels located on your computer (or other Dell digital device). The MOC label may be located separately from the other regulatory marking applied to your product. The English text, "EMI (A)," for Class A products, or "EMI (B)" for Class B products, appears in the center of the MOC label (see Figures D-3 and D-4).



NOTE: MOC emissions requirements provide for two classifications:

- Class A devices are for business purposes.
- Class B devices are for nonbusiness purposes.

Class A Device

장치 종류	사용자 안내문
A 급 기기	이 장치는 업무용으로 전자파 적합등록을 한 장치이오니 판매자 또는 사용자는 이 점을 주의하시기 바라며 만약 잘못 판매 또는 구입하였을 때에는 가정용으로 교환하시기 바랍니다.

Please note that this device has been approved for business purposes with regard to electromagnetic interference. If you find that this device is not suitable for your use, you may exchange it for a nonbusiness device.

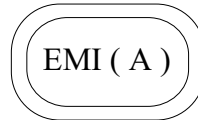

Figure D-3. MOC Class A Regulatory Mark

Class B Device

장치 종류	사용자 안내문
B 급 기기	이 장치는 가정용으로 전자파 적합등록을 한 장치로서 주거지역에서는 물론 모든 지역에서 사용할 수 있습니다.

Please note that this device has been approved for nonbusiness purposes and may be used in any environment, including residential areas.

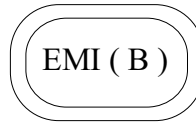

Figure D-4. MOC Class B Regulatory Mark

Polish Center for Testing and Certification Notice

The equipment should draw power from a socket with an attached protection circuit (a three-prong socket). All equipment that works together (computer, monitor, printer, and so on) should have the same power supply source.

The phasing conductor of the room's electrical installation should have a reserve short-circuit protection device in the form of a fuse with a nominal value no larger than 16 amperes (A).

To completely switch off the equipment, the power supply cable must be removed from the power supply socket, which should be located near the equipment and easily accessible.

A protection mark "B" confirms that the equipment is in compliance with the protection usage requirements of standards PN-93/T-42107 and PN-89/E-06251.

Wymagania Polskiego Centrum Badań i Certyfikacji

Urządzenie powinno być zasilane z gniazda z przyłączonym obwodem ochronnym (gniazdo z kołkiem). Współpracujące ze sobą urządzenia (komputer, monitor, drukarka) powinny być zasilane z tego samego źródła.

Instalacja elektryczna pomieszczenia powinna zawierać w przewodzie fazowym rezerwową ochronę przed zwarciami, w postaci bezpiecznika o wartości znamionowej nie większej niż 16A (amperów).

W celu całkowitego wyłączenia urządzenia z sieci zasilania, należy wyjąć wtyczkę kabla zasilającego z gniazodka, które powinno znajdować się w pobliżu urządzenia i być łatwo dostępne.

Znak bezpieczeństwa "B" potwierdza zgodność urządzenia z wymaganiami bezpieczeństwa użytkowania zawartymi w PN-93/T-42107 i PN-89/E-06251.

Pozostałe instrukcje bezpieczeństwa

- Nie należy używać wtyczek adapterowych lub usuwać kołka obwodu ochronnego z wtyczki. Jeżeli konieczne jest użycie przedłużacza to należy użyć przedłużacza 3-żyłowego z prawidłowo połączonym przewodem ochronnym.

- System komputerowy należy zabezpieczyć przed nagłymi, chwilowymi wzrostami lub spadkami napięcia, używając eliminatora przepięć, urządzenia dopasowującego lub bezzakłócenowego źródła zasilania.
- Należy upewnić się, aby nic nie leżało na kablach systemu komputerowego, oraz aby kable nie były umieszczone w miejscu, gdzie można byłoby na nie nadeptywać lub potykać się o nie.
- Nie należy rozlewać napojów ani innych płynów na system komputerowy.
- Nie należy wpychać żadnych przedmiotów do otworów systemu komputerowego, gdyż może to spowodować pożar lub porażenie prądem, poprzez zwarcie elementów wewnętrznych.
- System komputerowy powinien znajdować się z dala od grzejników i źródeł ciepła. Ponadto, nie należy blokować otworów wentylacyjnych. Należy unikać kładzenia luźnych papierów pod komputer oraz umieszczania komputera w ciasnym miejscu bez możliwości cyrkulacji powietrza wokół niego.

NOM Information (Mexico Only)

The following information is provided on the device(s) described in this document in compliance with the requirements of the official Mexican standards (NOM)

Exporter: Dell Computer Corporation
One Dell Way
Round Rock, TX 78682

Importer: Dell Computer de México,
S.A. de C.V.
Rio Lerma No. 302 - 4° Piso
Col. Cuauhtemoc
16500 México, D.F.

Ship to: Dell Computer de México,
S.A. de C.V. al Cuidado
de Kuehne & Nagel de
México S. de R.l.
Avenida Soles No. 55
Col. Peñon de los Baños
15520 México, D.F.

Supply voltage: 115/230 VAC

Frequency: 60/50 Hz

Current
consumption: 6.0/3.0 A

Información para NOM (únicamente para México)

La información siguiente se proporciona en el dispositivo o en los dispositivos descritos en este documento, en cumplimiento con los requisitos de la Norma Oficial Mexicana (NOM):

Exportador:	Dell Computer Corporation One Dell Way Round Rock, TX 78682
Importador:	Dell Computer de México, S.A. de C.V. Rio Lerma No. 302 - 4° Piso Col. Cuauhtemoc 16500 México, D.F.
Embarcar a:	Dell Computer de México, S.A. de C.V. al Cuidado de Kuehne & Nagel de México S. de R.L. Avenida Soles No. 55 Col. Peñon de los Baños 15520 México, D.F.
Tensión alimentación:	115/230 VAC
Frecuencia:	60/50 Hz
Consumo de corriente:	6.0/3.0 A

BCIQ Notice (Taiwan Only)

警告使用者：這是甲類的資訊產品，在居住的環境中使用時，可能會造成無線電干擾，在這種情況下，使用者會被要求採取某些適當的對策。



APPENDIX E

Warranty, Return Policy, and Year 2000 Statement of Compliance

Limited Three-Year Warranty (U.S. and Canada Only)

Dell Computer Corporation ("Dell") manufactures its hardware products from parts and components that are new or equivalent to new in accordance with industry-standard practices. Dell warrants that the hardware products it manufactures will be free from defects in materials and workmanship. The warranty term is three years beginning on the date of invoice, as described in the following text.

Damage due to shipping the products to you is covered under this warranty. Otherwise, this warranty does not cover damage due to external causes, including accident, abuse, misuse, problems with electrical power, servicing not authorized by Dell, usage not in accordance with product instructions, failure to perform required preventive maintenance, and problems caused by use of parts and components not supplied by Dell.

This warranty does not cover any items that are in one or more of the following categories: software; external devices (except as specifically noted); accessories or parts added to a Dell system after the system is shipped from Dell; accessories or parts added to a Dell system through Dell's system integration department; accessories or parts that are not installed in the Dell factory; or DellWare[®] products. Monitors, keyboards, and mice that are Dell-branded or that are included on Dell's standard price list are covered under this warranty; all other monitors, keyboards, and mice (including those sold through the DellWare program) are not covered. Batteries for portable computers are covered only during the initial one-year period of this warranty.

Coverage During Year One

During the one-year period beginning on the invoice date, Dell will repair or replace products covered under this limited warranty that are returned to Dell's facility. To request warranty service, you must call Dell's Customer Technical Support within the warranty period. Refer to the chapter titled "Getting Help" in your system's troubleshooting documentation or, for some systems, the section titled "Contacting Dell" in your system's online guide to find the appropriate telephone number for obtaining customer assistance. If warranty service is required, Dell will issue a Return Material

Authorization Number. You must ship the products back to Dell in their original or equivalent packaging, prepay shipping charges, and insure the shipment or accept the risk of loss or damage during shipment. Dell will ship the repaired or replacement products to you freight prepaid if you use an address in the continental U.S. or Canada, where applicable. Shipments to other locations will be made freight collect.



NOTE: Before you ship the product(s) to Dell, back up the data on the hard-disk drive(s) and any other storage device(s) in the product(s). Remove any removable media, such as diskettes, CDs, or PC Cards. Dell does not accept liability for lost data or software.

Dell owns all parts removed from repaired products. Dell uses new and reconditioned parts made by various manufacturers in performing warranty repairs and building replacement products. If Dell repairs or replaces a product, its warranty term is not extended.

Coverage During Years Two and Three

During the second and third years of this limited warranty, Dell will provide, on an exchange basis and subject to Dell's Exchange Policy in effect on the date of the exchange, replacement parts for the Dell hardware product(s) covered under this limited warranty when a part requires replacement. You must report each instance of hardware failure to Dell's Customer Technical Support in advance to obtain Dell's concurrence that a part should be replaced and to have Dell ship the replacement part. Dell will ship parts (freight prepaid) if you use an address in the continental U.S. or Canada, where applicable. Shipments to other locations will be made freight collect. Dell will include a prepaid shipping container with each replacement part for your use in returning the replaced part to Dell. Replacement parts are new or reconditioned. Dell may provide replacement parts made by various manufacturers when supplying parts to you. The warranty term for a replacement part is the remainder of the limited warranty term.

You will pay Dell for replacement parts if the replaced part is not returned to Dell. The process for returning replaced parts, and your obligation to pay for replacement parts if you do not return the replaced parts to Dell, will be in accordance with Dell's Exchange Policy in effect on the date of the exchange.

You accept full responsibility for your software and data. Dell is not required to advise or remind you of appropriate backup and other procedures.

General Provisions

DELL MAKES NO EXPRESS WARRANTIES OR CONDITIONS BEYOND THOSE STATED IN THIS WARRANTY STATEMENT. DELL DISCLAIMS ALL OTHER WARRANTIES AND CONDITIONS, EXPRESS OR IMPLIED, INCLUDING WITHOUT LIMITATION IMPLIED WARRANTIES AND CONDITIONS OF MERCHANTABILITY AND FITNESS FOR A PARTICULAR PURPOSE. SOME STATES (OR JURISDICTIONS) DO NOT ALLOW LIMITATIONS ON IMPLIED WARRANTIES OR CONDITIONS, SO THIS LIMITATION MAY NOT APPLY TO YOU.

DELL'S RESPONSIBILITY FOR MALFUNCTIONS AND DEFECTS IN HARDWARE IS LIMITED TO REPAIR AND REPLACEMENT AS SET FORTH IN THIS WARRANTY STATEMENT. THESE WARRANTIES GIVE YOU SPECIFIC LEGAL RIGHTS, AND YOU MAY ALSO HAVE OTHER RIGHTS, WHICH VARY FROM STATE TO STATE (OR JURISDICTION TO JURISDICTION).

DELL DOES NOT ACCEPT LIABILITY BEYOND THE REMEDIES SET FORTH IN THIS WARRANTY STATEMENT OR LIABILITY FOR INCIDENTAL OR CONSEQUENTIAL DAMAGES, INCLUDING WITHOUT LIMITATION ANY LIABILITY FOR PRODUCTS NOT BEING AVAILABLE FOR USE OR FOR LOST DATA OR SOFTWARE.

SOME STATES (OR JURISDICTIONS) DO NOT ALLOW THE EXCLUSION OR LIMITATION OF INCIDENTAL OR CONSEQUENTIAL DAMAGES, SO THE PRECEDING EXCLUSION OR LIMITATION MAY NOT APPLY TO YOU.

These provisions apply to Dell's limited three-year warranty only. For provisions of any service contract covering your system, refer to your invoice or the separate service contract that you will receive.

If Dell elects to exchange a system or component, the exchange will be made in accordance with Dell's Exchange Policy in effect on the date of the exchange. In any instance in which Dell issues a Return Materials Authorization Number, Dell must receive the product(s) for repair prior to the expiration of the warranty period in order for the repair(s) to be covered by the warranty.



NOTE: If you chose one of the available warranty and service options in place of the standard limited three-year warranty described in the preceding text, the option you chose will be listed on your invoice.

“Total Satisfaction” Return Policy (U.S. and Canada Only)

If you are an end-user customer who bought new products directly from a Dell company, you may return them to Dell within 30 days of the date of invoice for a refund or credit of the product purchase price. If you are an end-user customer who bought reconditioned or refurbished products from a Dell company, you may return them to Dell within 14 days of the date of invoice for a refund or credit of the product purchase price. In either case, the refund or credit will not include any shipping and handling charges shown on your invoice. If you are an organization that bought the products under a written agreement with Dell, the agreement may contain different terms for the return of products than specified by this policy.

To return products, you must call Dell Customer Service to receive a Credit Return Authorization Number. Refer to the chapter titled "Getting Help" in your system's troubleshooting documentation or, for some systems, the section titled "Contacting Dell" in your system's online guide to find the appropriate telephone number for obtaining customer assistance. To expedite the processing of your refund or credit, Dell expects you to return the products to Dell in their original packaging within five days of the date that Dell issues the Credit Return Authorization Number. You must also prepay shipping charges and insure the shipment or accept the risk of loss or damage

during shipment. You may return software for refund or credit only if the sealed package containing the diskette(s) or CD(s) is unopened. Returned products must be in as-new condition, and all of the manuals, diskette(s), CD(s), power cables, and other items included with a product must be returned with it. For customers who want to return, for refund or credit only, either applications software or an operating system that has been installed by Dell, the whole system must be returned, along with any media and documentation that may have been included in the original shipment.

This "Total Satisfaction" Return Policy does not apply to DellWare products, which may be returned under DellWare's then-current return policy. In addition, reconditioned parts purchased through Dell Spare Parts Sales in Canada are nonreturnable.

Year 2000 Statement of Compliance for Dell-Branded Hardware Products

Dell-branded hardware products shipped on or after January 1, 1997, are eligible to carry the "NSTL Hardware Tested Year 2000 Compliant" logo by virtue of formal testing with, and successful completion of, the National Software Testing Laboratories (NSTL) YMARK2000 test.* Dell will treat a failure to pass the YMARK2000 test as a covered event under Dell's warranty for the product, subject to the normal warranty limitations.** For a complete copy of Dell's warranty, see the product's documentation. Dell-branded hardware products will also recognize the year 2000 as a leap year.

*The YMARK2000 standard tests the ability of system hardware and firmware to support the transition to the year 2000 (and to recognize leap years, when appropriate, for years 2000 through 2009 inclusive) and not that of options, operating systems, or applications software. Dell-branded hardware products that pass the YMARK2000 test conform to BSI-DISC PD 2000-1.

** Except for this clarification of Dell's warranty for NSTL logo hardware, all other warranties, conditions and remedies, express or implied, relating to year 2000 readiness or compliance are disclaimed. To make a claim under this warranty for NSTL logo hardware, customers must contact Dell prior to January 1, 2001. Despite a system's ability to pass the YMARK2000 test, actual rollover results in specific operating environments may vary depending on other factors including, but not limited to, other hardware, operating systems, and applications software.

Previous Products

For Dell-branded hardware products shipped prior to January 1, 1997, that have an upgradable basic input/output system (BIOS), Dell makes available a BIOS upgrade. Although these products may not have been tested under the YMARK2000 test, Dell believes that the hardware would pass the YMARK2000 test, provided the appropriate BIOS upgrade is properly loaded.

For Dell-branded hardware products that do not have an upgradable BIOS, Dell has made available, as a convenience to customers, the Dell Program Patch, a software utility designed to assist customers in managing the year 2000 rollover.

Software

Dell specifically excludes all non-Dell-developed software from this compliance statement. All software run on Dell-branded hardware products should be independently verified by customers to be year 2000-compliant.

Additional Information

For additional information on year 2000 compliance of Dell-branded hardware products, refer to Dell's Year 2000 Web site at www.dell.com/year2000 or contact a Dell customer service representative in your area.



Glossary

The following list defines or identifies technical terms, abbreviations, and acronyms used in Dell user documents.

A

Abbreviation for ampere(s).

AC

Abbreviation for alternating current.

adapter card

An expansion card that plugs into an expansion-card connector on the computer's system board. An adapter card adds some specialized function to the computer by providing an interface between the expansion bus and a peripheral device. Examples of adapter cards include network cards, sound boards, and SCSI adapters.

ADC

Abbreviation for analog-to-digital converter.

ADI

Abbreviation for Autodesk Device Interface.

AGP

Abbreviation for advanced graphics port.

AI

Abbreviation for artificial intelligence.

ANSI

Acronym for American National Standards Institute.

application

Software designed to help you perform a specific task, such as a spreadsheet or word processor. Applications are distinct from operating system and utility software.

ASCII

Acronym for American Standard Code for Information Interchange. A text file containing only characters from the ASCII character set (usually created with a text editor, such as MS-DOS® Editor or Notepad in Windows), is called an ASCII file.

ASIC

Acronym for application-specific integrated circuit.

ASPI®

Advanced SCSI programming interface.

autoexec.bat file

When you boot your computer, MS-DOS runs any commands contained in the text file, **autoexec.bat** (after running any commands in the **config.sys** file). An **autoexec.bat** file is not required to boot MS-DOS, but provides a convenient place to run commands that are essential for setting up a consistent computing environment—such as loading mouse or network software.

backup

A copy of a program or data file. As a precaution, you should back up your computer's hard-disk drive on a regular basis. Before making a change to the configuration of your computer, you should

back up important start-up files, such as **autoexec.bat** and **config.sys** for MS-DOS or **win.ini** and **system.ini** for Windows.

base memory

Synonym for conventional memory. See also **conventional memory**.

BASIC

Acronym for Beginner's All-Purpose Symbolic Instruction Code, a programming language. MS-DOS includes a version of BASIC.

batch file

An ASCII text file containing a list of commands that run in sequence. Batch files must have a filename extension of **.bat**.

baud rate

Data transmission speed. For example, modems are designed to transmit data at one or more specified baud rate(s) through the COM (serial) port of a computer.

BBS

Abbreviation for bulletin board service. A computer system that serves as a central location for accessing data or relaying messages by modem. For example, Dell's TechConnect BBS contains the latest version of software such as video drivers and the *Dell Directory*. If your system has a modem, you can access the BBS and download the most recent version of this software.

beep code

A diagnostic system message in the form of a series of beeps from your computer's speaker. Refer to your *Diagnostics and Troubleshooting Guide* for a complete discussion of system beep codes.

BIOS

Acronym for basic input/output system. Your computer's BIOS contains programs stored on a ROM chip. The BIOS controls the following:

- Communications between the microprocessor and peripheral

devices, such as the keyboard and the video adapter

- Miscellaneous functions, such as system messages

bit

The smallest unit of information interpreted by your computer.

block

A typical unit of disk storage consisting of a small number of sectors. This term usually refers to the fundamental unit of storage provided by an operating system. See also **block size** and **striping**.

block size

The size of a block. See also **block** and **striping**.

boot routine

When you start your computer, it clears all memory, initializes devices, and loads the operating system. Unless the operating system fails to respond, you can reboot (also called warm boot) your computer by pressing <Ctrl><Alt>; otherwise, you must perform a cold boot by pressing the reset button (if your computer has one) or by turning the computer off, then back on.

bootable diskette

You can start your computer from a diskette in drive A. To make a bootable diskette, insert a diskette in drive A, type `sys a:` at the command line prompt, then press <Enter>. Use this bootable diskette if your computer will not boot from the hard-disk drive.

bpi

Abbreviation for bits per inch.

bps

Abbreviation for bits per second.

BTU

Abbreviation for British thermal unit.

bus

A bus forms an information pathway between the components of a computer. Your computer contains an expansion bus

that allows the microprocessor to communicate with controllers for all the various peripheral devices connected to the computer. Your computer also contains an address bus and a data bus for communications between the microprocessor and RAM.

byte

Eight contiguous bits of information, the basic data unit used by your computer.

BZT

Abbreviation for *Bundesamt fur Zulassungen in der Telekommunikation*.

C

Abbreviation for Celsius.

cache

To facilitate quicker data retrieval, a storage area for keeping a copy of data or instructions. For example, your computer's BIOS may cache ROM code in faster RAM. Or, a disk-cache utility may reserve RAM in which to store frequently accessed information from your computer's disk drives; when a program makes a request to a disk drive for data that is in the cache, the disk-cache utility can retrieve the data from RAM faster than from the disk drive.

card-edge connector

On the bottom of an expansion card, the metal-contact section that plugs into an expansion-card connector.

CCFT

Abbreviation for cold cathode fluorescent tube.

CD-ROM

Abbreviation for compact disc read-only memory. CD-ROM drives use optical technology to read data from compact discs. Compact discs are read-only storage devices; you cannot write new data to a compact disc with standard CD-ROM drives.

CGA

Abbreviation for color graphics adapter.

cm

Abbreviation for centimeter(s).

CMOS

Acronym for complementary metal-oxide semiconductor. In computers, CMOS memory chips are often used for NVRAM storage.

COMn

The MS-DOS device names for the first through fourth serial ports on your computer are COM1, COM2, COM3, and COM4. MS-DOS supports up to four serial ports. However, the default interrupt for COM1 and COM3 is IRQ4, and the default interrupt for COM2 and COM4 is IRQ3. Therefore, you must be careful when configuring software that runs a serial device so that you don't create an interrupt conflict.

CON

The MS-DOS device name for the console, which includes your computer's keyboard and text displayed on the screen.

config.sys file

When you boot your computer, MS-DOS runs any commands contained in the text file, **config.sys** (before running any commands in the **autoexec.bat** file). A **config.sys** file is not required to boot MS-DOS, but provides a convenient place to run commands that are essential for setting up a consistent computing environment—such as loading device drivers with a **device=** statement.

controller

A chip or expansion card that controls the transfer of data between the microprocessor and a peripheral, such as a disk drive or the keyboard.

conventional memory

The first 640 KB of RAM. Unless they are specially designed, MS-DOS programs are limited to running in conventional memory. See also **EMM**, **expanded memory**, **extended memory**, **HMA**, **memory manager**, **upper memory area**, and **XMM**.

coprocessor

A coprocessor relieves the computer's microprocessor of specific processing tasks. A math coprocessor, for example,

handles numeric processing. A graphics coprocessor handles video rendering. The Intel® Pentium® microprocessor includes a built-in math coprocessor.

cpi

Abbreviation for characters per inch.

CPU

Abbreviation for central processing unit. See also **microprocessor**.

cursor

In character-based MS-DOS programs, the cursor is usually a block or an underscore (possibly blinking) that represents the position at which the next character typed will appear. Windows programs can design their own cursors—common cursor symbols include the pointer arrow and the text-insertion I-beam.

DAC

Acronym for digital-to-analog converter.

DAT

Acronym for digital audio tape.

dB

Abbreviation for decibel(s).

dBA

Abbreviation for adjusted decibel(s).

DC

Abbreviation for direct current.

device driver

A device driver allows the operating system or a program to interface correctly with a peripheral, such as a printer or network card. Some device drivers—such as network drivers—must be loaded from the **config.sys** file (with a **device=** statement) or as memory-resident programs (usually, from the **autoexec.bat** file). Others—such as video drivers—must load when you start the program for which they were designed.

diagnostics

See **diskette-based diagnostics**.

DIMM

Acronym for dual in-line memory module.

DIN

Acronym for *Deutsche Industrie Norm*.

DIP

Acronym for dual in-line package. A circuit board, such as a system board or expansion card, may contain DIP switches for configuring the circuit board. DIP switches are always toggle switches, with an ON position and an OFF position.

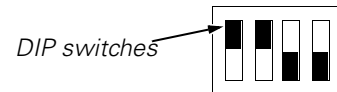

directory

Directories help keep related files organized on a disk in a hierarchical, “inverted tree” structure. Each disk has a “root” directory; for example, a `c:\>` prompt normally indicates that you are at the root directory of hard-disk drive C. Additional directories that branch off of the root directory are called *subdirectories*. Subdirectories may contain additional directories branching off of them.

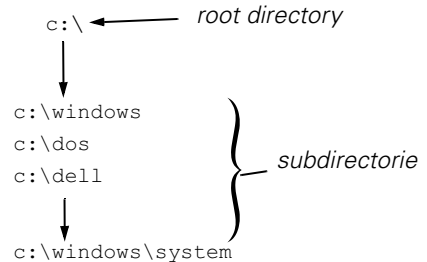

diskette-based diagnostics

A comprehensive set of diagnostic tests for your Dell computer. To use the diskette-based diagnostics, you must boot your computer from the *Dell Diagnostics Diskette*. Refer to your *Installation and Troubleshooting Guide* for a complete discussion about how to use the diskette-based diagnostics.

display adapter

See **video adapter**.

DMA

Abbreviation for direct memory access. A DMA channel allows certain types of data transfer between RAM and a device to bypass the microprocessor.

DOC

Abbreviation for Department of Communications (in Canada).

dpi

Abbreviation for dots per inch.

DPMS

Abbreviation for Display Power Management Signaling. A standard developed by the Video Electronics Standards Association that defines the hardware signals sent by a video controller to activate power management states in a video display or monitor. A monitor is said to be DPMS-compliant when it is designed to enter a power management state after receiving the appropriate signal from a computer's video controller.

DRAC

Abbreviation for Dell Remote Assistant Card.

DRAM

Abbreviation for dynamic random-access memory. A computer's RAM is usually made up entirely of DRAM chips. Because DRAM chips cannot store an electrical charge indefinitely, your computer continually refreshes each DRAM chip in the computer.

drive-type number

Your computer can recognize a number of specific hard-disk drives. Each is assigned a drive-type number that is stored in NVRAM. The hard-disk drive(s) specified in your computer's System Setup program must match the actual drive(s) installed in the computer. The System Setup program also allows you to specify physical parameters (cylinders, heads, write precomp, landing zone, and capacity) for drives not included in the table of drive types stored in NVRAM.

DS/DD

Abbreviation for double-sided/double-density.

DS/HD

Abbreviation for double-sided/high-density.

DTE

Abbreviation for data terminal equipment. Any device (such as a computer system) that can send data in digital form by means of a cable or communications line. The DTE is connected to the cable or communications line through a data communications equipment (DCE) device, such as a modem.

ECC

Abbreviation for error checking and correction.

ECP

Abbreviation for Extended Capabilities Port.

EDO

Abbreviation for extended-data output. A type of RAM chip that holds data on the chip's output data lines for a longer period of time than fast-page mode RAM chips. The EDO RAM chips are also faster than fast-page mode RAM chips.

EEPROM

Acronym for electrically erasable programmable read-only memory.

EGA

Abbreviation for enhanced graphics adapter.

EISA

Acronym for Extended Industry-Standard Architecture, a 32-bit expansion-bus design. The expansion-card connectors in an EISA computer are also compatible with 8- or 16-bit ISA expansion cards.

To avoid a configuration conflict when installing an EISA expansion card, you must use the EISA Configuration Utility. This utility allows you to specify which expansion slot contains the card and obtains information about the card's required

system resources from a corresponding EISA configuration file.

EMC

Abbreviation for Electromagnetic Compatibility.

EMI

Abbreviation for electromagnetic interference.

EMM

Abbreviation for expanded memory manager. A software utility that uses extended memory to emulate expanded memory on computers with an Intel386™ or higher microprocessor. See also **conventional memory**, **expanded memory**, **extended memory**, **memory manager**, and **XMM**.

EMS

Abbreviation for Expanded Memory Specification. See also **expanded memory**, **memory manager**, and **XMS**.

EPROM

Acronym for erasable programmable read-only memory.

ESD

Abbreviation for electrostatic discharge. Refer to "Safety Instructions" at the front of your *User's Guide* for a complete discussion of ESD.

ESDI

Acronym for enhanced small-device interface.

expanded memory

A technique for accessing RAM above 1 MB. To enable expanded memory on your computer, you must use an EMM. You should configure your system to support expanded memory only if you run application programs that can use (or require) expanded memory. See also **conventional memory**, **EMM**, **extended memory**, and **memory manager**.

expansion bus

Your computer contains an expansion bus that allows the microprocessor to communicate with controllers for peripheral

devices, such as a network card or an internal modem.

expansion-card connector

A connector on the computer's system board for plugging in an expansion card.

extended memory

RAM above 1 MB. Most software that can use it, such as Windows, requires that extended memory be under the control of an XMM. See also **conventional memory**, **expanded memory**, **memory manager**, and **XMM**.

external cache memory

A RAM cache using SRAM chips. Because SRAM chips operate at several times the speed of DRAM chips, the microprocessor can retrieve data and instructions faster from external cache memory than from RAM.

F

Abbreviation for Fahrenheit.

FAT

Acronym for file allocation table. The file system structure used by MS-DOS to organize and keep track of file storage. The Microsoft® Windows NT® operating system can optionally use a FAT file system structure.

FCC

Abbreviation for Federal Communications Commission.

flash memory

A type of EEPROM chip that can be reprogrammed from a utility on diskette while still installed in a computer; most EEPROM chips can only be rewritten with special programming equipment.

format

To prepare a hard-disk drive or diskette for storing files. An unconditional format deletes all data stored on the disk. The **format** command in MS-DOS 5.0 or higher includes an option that allows you to unformat a disk, if you have not yet used the disk for file storage.

ft
Abbreviation for feet.

FTP
Abbreviation for File Transfer Protocol.

g
Abbreviation for gram(s).

G
Abbreviation for gravities.

GB
Abbreviation for gigabyte(s). A gigabyte equals 1,024 megabytes or 1,073,741,824 bytes.

graphics coprocessor
See **coprocessor**.

graphics mode
See **video mode**.

guarding
A type of data redundancy that uses a set of physical drives to store data and a single, additional drive to store parity data. Using guarding, the user's data is protected from the loss of a single drive. Guarding is sometimes preferred over mirroring because it is more cost effective in systems with a very high storage capacity. However, guarded configurations are significantly slower for applications that frequently write to the array, because each attempt to write to the array requires multiple read and write commands to maintain the parity information. If this is a problem, mirroring or duplexing is a better choice. See also **mirroring**, **RAID 4**, and **RAID 5**.

GUI
Acronym for graphical user interface.

h
Abbreviation for hexadecimal. A base-16 numbering system, often used in programming to identify addresses in the computer's RAM and I/O memory addresses for devices. The sequence of decimal numbers from 0 through 16, for example, is expressed in hexadecimal notation as: 0, 1, 2, 3, 4, 5, 6, 7, 8, 9, A, B,

C, D, E, F, 10. In text, hexadecimal numbers are often followed by *h* or preceded by *0x*. MS-DOS conventional memory—the first 640 KB of memory addresses—is from 00000h to 9FFFFh; the MS-DOS upper memory area—memory addresses between 640 KB and 1 MB—is from A0000h to FFFFFh.

heat sink
A metal plate with metal pegs or ribs that help dissipate heat. Some microprocessors include a heat sink.

HIP
Acronym for Hardware Instrumentation Package (HIP)

HMA
Abbreviation for high memory area. The first 64 KB of extended memory above 1 MB. A memory manager that conforms to the XMS can make the HMA a direct extension of conventional memory. See also **conventional memory**, **memory manager**, **upper memory area**, and **XMM**.

host adapter
A host adapter implements communication between the computer's bus and the controller for a peripheral. (Hard-disk drive controller subsystems include integrated host adapter circuitry.) To add a SCSI expansion bus to your system, you must install the appropriate host adapter.

HPFS
Abbreviation for the High Performance File System option in the Windows NT operating system.

Hz
Abbreviation for hertz.

I/O
Abbreviation for input/output. The keyboard and a printer, for example, are I/O devices. In general, I/O activity can be differentiated from computational activity. For example, when a program sends a document to the printer, it is engaging in I/O activity; when the program sorts a list of terms, it is engaging in computational activity.

ID

Abbreviation for identification.

interlacing

A technique for increasing video resolution by only updating alternate horizontal lines on the screen. Because interlacing can result in noticeable screen flicker, most users prefer noninterlaced video adapter resolutions.

internal microprocessor cache

An instruction and data cache built in to the microprocessor. The Pentium microprocessor, for example, includes a 16-KB internal cache, which is set up as an 8-KB read-only instruction cache and an 8-KB read/write data cache.

IP

Abbreviation for Internet Protocol.

IPX

Acronym for internetwork packet exchange.

IRQ

Abbreviation for interrupt request. A signal that data is about to be sent to or received by a peripheral travels by an IRQ line to the microprocessor. Each peripheral connection must be assigned an IRQ number. For example, the first serial port in your computer (COM1) is assigned to IRQ4 by default. Two devices can share the same IRQ assignment, but you cannot operate both devices simultaneously.

ISA

Acronym for Industry-Standard Architecture. A 16-bit expansion bus design. The expansion-card connectors in an ISA computer are also compatible with 8-bit ISA expansion cards.

ITE

Abbreviation for information technology equipment.

JEIDA

Acronym for Japanese Electronic Industry Development Association.

K

Abbreviation for kilo-, indicating 1,000.

KB

Abbreviation for kilobyte(s), 1,024 bytes.

KB/sec

Abbreviation for kilobyte(s) per second.

Kb(s)

Abbreviation for kilobit(s), 1,024 bits.

Kbps

Abbreviation for kilobit(s) per second.

key combination

A command requiring that you press multiple keys at the same time. For example, you can reboot your computer by pressing the <Ctrl><Alt> key combination.

kg

Abbreviation for kilogram(s), 1,000 grams.

kHz

Abbreviation for kilohertz, 1,000 hertz.

LAN

Acronym for local area network. A LAN system is usually confined to the same building or a few nearby buildings, with all equipment linked by wiring dedicated specifically to the LAN.

lb

Abbreviation for pound(s).

LCD

Abbreviation for liquid crystal display. A low-power display often used for notebook computers. An LCD consists of a liquid crystal solution between two sheets of polarizing material. An electric current causes each crystal to act like a shutter that can open to allow light past or close to block the light.

LED

Abbreviation for light-emitting diode. An electronic device that lights up when a current is passed through it.

LIF

Acronym for low insertion force. Some computers use LIF sockets and connectors to allow devices such as the microprocessor chip to be installed or removed with minimal stress to the device.

LIM

Acronym for Lotus/Intel/Microsoft. LIM usually refers to version 4.0 of the EMS.

LN

Abbreviation for load number.

local bus

On a computer with local-bus expansion capability, certain peripheral devices (such as the video adapter circuitry) can be designed to run much faster than they would with a traditional expansion bus. Some local-bus designs allow peripherals to run at the same speed and with the same width data path as the computer's microprocessor.

LPTn

The MS-DOS device names for the first through third parallel printer ports on your computer are LPT1, LPT2, and LPT3.

LUN

Acronym for logical unit number.

LVD

Acronym for low voltage differential.

m

Abbreviation for meter(s).

mA

Abbreviation for milliampere(s).

mAh

Abbreviation for milliampere-hour(s).

math coprocessor

See **coprocessor**.

MB

Abbreviation for megabyte(s). The term *megabyte* means 1,048,576 bytes; however, when referring to hard-disk drive storage, the term is often rounded to mean 1,000,000 bytes.

MBR

Abbreviation for master boot record.

MDA

Abbreviation for monochrome display adapter.

memory

A computer can contain several different forms of memory, such as RAM, ROM, and video memory. Frequently, the word *memory* is used as a synonym for RAM; for example, an unqualified statement such as "...a computer with 8 MB of memory" refers to a computer with 8 MB of RAM.

memory address

A specific location, usually expressed as a hexadecimal number, in the computer's RAM.

memory manager

A utility that controls the implementation of memory in addition to conventional memory, such as extended or expanded memory. See also **conventional memory**, **EMM**, **expanded memory**, **extended memory**, **HMA**, **upper memory area**, and **XMM**.

MGA

Abbreviation for monochrome graphics adapter.

MHz

Abbreviation for megahertz.

microprocessor

Because it is the primary computational chip inside the computer, it is customary to refer to the microprocessor as "the computer's brain." The microprocessor contains an arithmetic processing unit and a control unit. Software written for one microprocessor must usually be revised to run on another microprocessor. *CPU* is a synonym for microprocessor.

min

Abbreviation for minute(s).

mirroring

A type of data redundancy that uses a set of physical drives to store data and one or more sets of additional drives to store duplicate copies of the data. Mirroring is the preferred data redundancy technique in lower-capacity systems and in systems where performance is extremely important. See also **guarding**, **RAID 1**, and **RAID 10**.

mm

Abbreviation for millimeter(s).

MMX

The microprocessors for this system include media enhancement technology which is designed to handle complex multimedia and communications software.

mouse

A pointing device that controls the movement of the cursor on a screen. Mouse-aware software allows you to activate commands by clicking a mouse button while pointing at objects displayed on the screen.

ms

Abbreviation for millisecond(s).

MS-DOS

Abbreviation for Microsoft Disk Operating System.

MTBF

Abbreviation for mean time between failures.

multifrequency monitor

A monitor that supports several video standards. A multifrequency monitor can adjust to the frequency range of the signal from a variety of video adapters.

mV

Abbreviation for millivolt(s).

NiCad

Acronym for nickel cadmium.

NiMH

Abbreviation for nickel-metal hydride.

NLM

Acronym for NetWare® Loadable Module.

NNM SE

Acronym for Network Node Manager Special Edition

NMI

Abbreviation for nonmaskable interrupt. A device sends an NMI to signal the microprocessor about hardware errors, such as a parity error.

noninterlaced

A technique for decreasing screen flicker by sequentially refreshing each horizontal line on the screen.

ns

Abbreviation for nanosecond(s), one billionth of a second.

NTFS

Abbreviation for the NT File System option in the Windows NT operating system.

NVRAM

Abbreviation for nonvolatile random-access memory. Memory that does not lose its contents when you turn off your computer. NVRAM is used for maintaining the date, time, and system setup options.

OTP

Abbreviation for one-time programmable.

parallel port

An I/O port used most often to connect a parallel printer to your computer. You can usually identify a parallel port on your computer by its 25-hole connector.

parameter

A value or option that you specify to a program. A parameter is sometimes called a *switch* or an *argument*.

partition

You can divide a hard-disk drive into multiple physical sections called *partitions* with the **fdisk** command. Each partition can contain multiple logical drives. For example, you could partition a 200-MB hard-disk drive into two physically separate partitions with three logical drive

assignments, as shown in the following table.

Partitioning the Hard-Disk Drive

Physical Partitions and Sizes

Partition 1 120 MB
Partition 2 80 MB

Logical Drive Assignments and Sizes

Drive C 120 MB
Drive D 50 MB
Drive E 30 MB

After partitioning the hard-disk drive, you must format each logical drive with the **format** command.

PC Card

Slightly larger than a credit card, a PC Card is a removable I/O card—such as a modem, LAN, SRAM, or flash memory card—that adheres to the PCMCIA standards. See also **PCMCIA**.

PCI

Abbreviation for Peripheral Component Interconnect. A standard for local-bus implementation developed by Intel Corporation.

PCMCIA

Abbreviation for Personal Computer Memory Card International Association. See also **PC Card**.

peripheral device

An internal or external device—such as a printer, a disk drive, or a keyboard—connected to a computer.

PGA

Abbreviation for pin grid array, a type of microprocessor socket that allows you to remove the microprocessor chip.

pixel

Arranged in rows and columns, a pixel is a single point on a video display. Video resolution—640 x 480, for example—is expressed as the number of pixels across by the number of pixels up and down.

POST

Acronym for power-on self-test. Before the operating system loads when you turn on your computer, the POST tests various system components such as RAM, the disk drives, and the keyboard.

ppm

Abbreviation for pages per minute.

PQFP

Abbreviation for plastic quad flat pack, a type of microprocessor socket in which the microprocessor chip is permanently mounted.

PRN

A synonym for the MS-DOS device name LPT1.

program diskette set

The set of diskettes from which you can perform a complete installation of an application program. When you reconfigure a program, you often need its program diskette set.

protected mode

An operating mode supported by 80286 or higher microprocessors, protected mode allows operating systems to implement:

- A memory address space of 16 MB (80286 microprocessor) to 4 GB (Intel386 or higher microprocessor)
- Multitasking
- Virtual memory, a method for increasing addressable memory by using the hard-disk drive

The Windows NT 32-bit operating system runs in protected mode. MS-DOS cannot run in protected mode; however, some programs that you can start from MS-DOS—such as Windows—are able to put the computer into protected mode.

PS/2

Abbreviation for Personal System/2.

PSPB

Abbreviation for power-supply paralleling board.

PVC

Abbreviation for polyvinyl chloride.

QIC

Abbreviation for quarter-inch cartridge.

RAM

Acronym for random-access memory. The computer's primary temporary storage area for program instructions and data. Each location in RAM is identified by a number called a *memory address*. Any information stored in RAM is lost when you turn off your computer.

RAID

Acronym for redundant array of inexpensive disks. This phrase was introduced by David Patterson, Garth Gibson, and Randy Katz at the University of California at Berkeley in 1987. The goal of RAID is to use multiple small, inexpensive disk drives to provide high storage capacity and performance while maintaining or improving the reliability of the disk subsystem.

Patterson, Gibson, and Katz described five different methods, which are known as RAID levels 1 through 5. Each level uses one or more extra drives to provide a means of recovering data lost when a disk fails, so that the effective failure rate of the whole disk subsystem becomes very low.

Recently, Katz has defined a sixth method, RAID 6, which improves reliability even further, and a configuration that provides no data recovery has popularly become known as RAID 0.

RAID 0

RAID 0 is commonly called *striping*. This was not originally defined as a RAID level but has since come into popular use. In this array configuration, data is written sequentially across the available disks and no redundancy is provided. RAID 0 configurations provide very high performance but relatively low reliability. RAID 0 is the best choice when DSA controller cards are duplexed. See also **striping**.

RAID 1

RAID 1 is commonly called *mirroring*. RAID 1 is the best choice in high-availability applications that require high performance or relatively low data capacity. See also **mirroring, RAID 10**

RAID 3

RAID 3 is commonly called *striping*. RAID 3 uses striping with one drive dedicated to parity to protect data. Data is striped such that a single transaction requires access to all drives. See also **striping**.

RAID 4

RAID 4 is commonly called *guarding*. It uses data striping, like RAID 3, but adds a single, dedicated parity drive. The parity data stored on this drive can be used to recover data lost from a single failed drive. RAID 4 configurations write data slowly because parity data has to be generated and written to the parity drive, and the generation of the parity data frequently requires reading data from multiple physical drives. See also **guarding and striping**.

RAID 5

RAID 5, like RAID 4, is commonly called *guarding*. RAID 5 is identical to RAID 4, except that the parity data is distributed evenly across all physical drives instead of a parity drive. In configurations using a large number of physical drives in which a large number of simultaneous small write operations are being performed, RAID 5 offers potentially higher performance than RAID 4. RAID 4 and RAID 5 configurations are appropriate in high-availability applications where performance is less critical or where high data capacity is required. See also **guarding**.

RAID 10

RAID 10 is a *mirroring* technique in which data is duplicated across two identical RAID 0 arrays or hard-disk drives. All data on a physical drive in one array is duplicated, or *mirrored*, on a drive in the second array. Mirroring offers complete redundancy of data for greater data security. See also **mirroring, RAID 1, and striping**.

RAMDAC

Acronym for random-access memory digital-to-analog converter.

RCU

Acronym for Resource Configuration Utility

read-only file

A read-only file is one that you are prohibited from editing or deleting. A file can have read-only status if:

- Its read-only attribute is enabled.
- It resides on a physically write-protected diskette.
- It is located on a network in a directory to which the system administrator has assigned read-only rights to you.

real mode

An operating mode supported by 80286 or higher microprocessors, real mode imitates the architecture of an 8086 microprocessor. Designed to run in real mode, MS-DOS (unassisted by additional software techniques) can address only 640 KB of conventional memory.

refresh rate

The frequency, measured in Hz, at which the screen's horizontal lines are recharged. A monitor's refresh rate is also referred to as its *vertical frequency*.

REN

Abbreviation for ringer equivalence number.

RFI

Abbreviation for radio frequency interference.

RGB

Abbreviation for red/green/blue.

ROM

Acronym for read-only memory. Your computer contains some programs essential to its operation in ROM code. Unlike RAM, a ROM chip retains its contents even after you turn off your

computer. Examples of code in ROM include the program that initiates your computer's boot routine and the POST.

rpm

Abbreviation for revolutions per minute.

RTC

Abbreviation for real-time clock. Battery-powered clock circuitry inside the computer that keeps the date and time after you turn off the computer.

SCSI

Acronym for small computer system interface. An I/O bus interface with faster data transmission rates than standard ports. You can connect up to seven devices to one SCSI interface.

SDMS

Abbreviation for SCSI device management system.

SDRAM

Abbreviation for synchronous dynamic random-access memory.

SEC

Abbreviation for single-edge connector cartridge.

sec

Abbreviation for second(s).

serial port

An I/O port used most often to connect a modem or a mouse to your computer. You can usually identify a serial port on your computer by its 9-pin connector.

shadowing

A computer's system and video BIOS code is usually stored on ROM chips. Shadowing refers to the performance-enhancement technique that copies BIOS code to faster RAM chips in the upper memory area (above 640 KB) during the boot routine.

SRAM

Abbreviation for static random-access memory. Because SRAM chips do not require continual refreshing, they are

substantially faster than DRAM chips. SRAM is used mostly for external cache memory.

striping

In composite drivers with two or more physical drives, the drive array subsystem uses a method of data storage called *striping*. With this method, data is divided into a series of pieces called *blocks* and each data block is stored on a different physical drive. When each drive contains a block of data, the process starts over with the first physical drive. By carefully selecting the size of the data block, the chance that the information needed can be read from or written to multiple physical drives at once is increased, greatly increasing the performance of the composite drive. See also **block**, **block size**, and **RAID**.

SVGA

Abbreviation for super video graphics array. See also **VGA**.

switch

See **parameter**.

sync negotiation

Sync negotiation is a SCSI feature that allows the host adapter and its attached SCSI devices to transfer data in synchronous mode. Synchronous data transfer is faster than asynchronous data transfer.

syntax

The rules that dictate how you must type a command or instruction so that the computer will understand it.

system board

As the main circuit board, the system board usually contains most of your computer's integral components, such as the following:

- Microprocessor
- RAM
- Expansion-card connectors

- Controllers for standard peripheral devices, such as the keyboard
- Various ROM chips

Frequently used synonyms for system board are *motherboard* and *logic board*.

system diskette

System diskette is a synonym for *bootable diskette*.

system memory

System memory is a synonym for *RAM*.

System Setup program

System Setup program options allow you to configure your computer's hardware. Some options in the System Setup program require that you reboot the computer in order to make a hardware-configuration change. Because the System Setup program is stored in NVRAM, any options that you set remain in effect until you change them again.

system.ini file

When you start Windows, it consults the **system.ini** file to determine a variety of options for the Windows operating environment. Among other things, the **system.ini** file records which video, mouse, and keyboard drivers are installed for Windows.

Running the Control Panel or Windows Setup program may change options in the **system.ini** file. On other occasions, you may need to change or add options to the **system.ini** file manually with a text editor, such as Notepad.

terminator

Some devices, especially disk drives, contain a terminator to absorb and dissipate excess current. When more than one such device is connected in a series, you may need to remove the terminator—or change a jumper setting to disable it—unless it is the last device in the series. However, some devices have terminators that should never be removed or disabled.

text editor

An application program for editing text files consisting exclusively of ASCII characters. MS-DOS Editor and Notepad (in Windows) are text editors, for example. Most word processors use proprietary file formats containing binary characters, although some can read and write text files.

text mode

See **video mode**.

TFT

Abbreviation for thin film transistor. A flat-panel display for notebook computers where each pixel is controlled by one to four transistors.

tpi

Abbreviation for tracks per inch.

TSR

Abbreviation for terminate-and-stay-resident. A TSR program runs "in the background." Most TSR programs implement a predefined key combination (sometimes referred to as a "hot key") that allows you to activate the TSR program's interface while running another MS-DOS program. When you finish using the TSR program, you can return to the other application program and leave the TSR program resident in memory for later use.

Because MS-DOS is not designed to support multiple programs running simultaneously, TSR programs can sometimes cause memory conflicts. When troubleshooting, rule out the possibility of such a conflict by rebooting your computer without starting any TSR programs.

TV

Abbreviation for television.

UL

Abbreviation for Underwriters Laboratories.

UMB

Abbreviation for upper memory blocks. See also **conventional memory**, **HMA**, **memory manager**, and **upper memory area**.

upper memory area

The 384 KB of RAM located between 640 KB and 1 MB. If the computer has an Intel386 or higher microprocessor, a software utility called a *memory manager* can create UMBs in the upper memory area, in which you can load device drivers and memory-resident programs. See also **conventional memory**, **HMA**, and **memory manager**.

UPS

Abbreviation for uninterruptible power supply. A battery-powered unit that automatically supplies power to your computer in the event of an electrical failure.

USOC

Abbreviation for Universal Service Ordering Code.

utility

A program used to manage system resources— memory, disk drives, or printers, for example. The **diskcopy** command for duplicating diskettes and the **himem.sys** device driver for managing extended memory are utilities included in MS-DOS.

V

Abbreviation for volt(s).

VAC

Abbreviation for volt(s) alternating current.

VCCI

Abbreviation for Voluntary Control Council for Interference.

VDC

Abbreviation for volt(s) direct current.

VDE

Abbreviation for *Verband Deutscher Elektrotechniker*.

VDS

Abbreviation for Virtual Direct Memory Access Services.

VESA®

Acronym for Video Electronics Standards Association.

VGA

Abbreviation for video graphics array. VGA and SVGA are video standards for video adapters with greater resolution and color display capabilities than EGA and CGA, the previous standards.

To display a program at a specific resolution, you must install the appropriate video drivers and your monitor must support the resolution. Similarly, the number of colors that a program can display depends on the capabilities of the monitor, the video driver, and the amount of memory installed for the video adapter.

VGA feature connector

On some systems with a built-in VGA video adapter, a VGA feature connector allows you to add an enhancement adapter, such as a video accelerator, to your computer. A VGA feature connector can also be called a *VGA pass-through connector*.

video adapter

The logical circuitry that provides—in combination with the monitor or display—your computer's video capabilities. A video adapter may support more or fewer features than a specific monitor offers. Typically, a video adapter comes with video drivers for displaying popular application programs and operating environments in a variety of video modes.

On most current Dell computers, a video adapter is integrated into the system board. Also available are many video adapter cards that plug into an expansion-card connector.

Video adapters can include memory separate from RAM on the system board. The amount of video memory, along with the adapter's video drivers, may affect the number of colors that can be

simultaneously displayed. Video adapters can also include their own coprocessor chip for faster graphics rendering.

video driver

Graphics-mode application programs and operating environments, such as Windows, often require video drivers in order to display at a chosen resolution with the desired number of colors. A program may include some "generic" video drivers. Any additional video drivers may need to match the video adapter; you can find these drivers on a separate diskette with your computer or video adapter.

video memory

Most VGA and SVGA video adapters include VRAM or DRAM memory chips in addition to your computer's RAM. The amount of video memory installed primarily influences the number of colors that a program can display (with the appropriate video drivers and monitor capability).

video mode

Video adapters normally support multiple text and graphics display modes. Character-based software (such as MS-DOS) displays in text modes that can be defined as *x* columns by *y* rows of characters. Graphics-based software (such as Windows) displays in graphics modes that can be defined as *x* horizontal by *y* vertical pixels by *z* colors.

video resolution

Video resolution—640 x 480, for example—is expressed as the number of pixels across by the number of pixels up and down. To display a program at a specific graphics resolution, you must install the appropriate video drivers and your monitor must support the resolution.

virtual 8086 mode

An operating mode supported by Intel386 or higher microprocessors, virtual 8086 mode allows operating environments—such as Windows—to run multiple programs in separate 1-MB sections of memory. Each 1-MB section is called a *virtual machine*.

virtual memory

A method for increasing addressable RAM by using the hard-disk drive. (MS-DOS does not support true virtual memory, which must be implemented at the operating system level.) For example, in a computer with 8 MB of RAM and 16 MB of virtual memory set up on the hard-disk drive, the operating system would manage the system as though it had 24 MB of physical RAM.

virus

A self-starting program designed to inconvenience you. Virus programs have been known to corrupt the files stored on a hard-disk drive or to replicate themselves until a system or network runs out of memory.

The most common way that virus programs move from one system to another is via "infected" diskettes, from which they copy themselves to the hard-disk drive. To guard against virus programs, you should do the following:

- Periodically run a virus-checking utility on your computer's hard-disk drive
- Always run a virus-checking utility on any diskettes (including commercially sold software) before using them

VL-Bus™

An abbreviation for VESA® local bus. A standard for local bus implementation developed by the Video Electronics Standards Association.

VLSI

Abbreviation for very-large-scale integration.

Vpp

Abbreviation for peak-point voltage.

VRAM

Abbreviation for video random-access memory. Some video adapters use VRAM chips (or a combination of VRAM and DRAM) to improve video performance.

VRAM is dual-ported, allowing the video adapter to update the screen and receive new image data at the same time.

W

Abbreviation for watt(s).

win.ini file

When you start Windows, it consults the **win.ini** file to determine a variety of options for the Windows operating environment. Among other things, the **win.ini** file records what printer(s) and fonts are installed for Windows. The **win.ini** file also usually includes sections that contain optional settings for Windows application programs that are installed on the hard-disk drive.

Running the Control Panel or Windows Setup program may change options in the **win.ini** file. On other occasions, you may need to change or add options to the **win.ini** file manually with a text editor, such as Notepad.

write-protected

Read-only files are said to be *write-protected*. You can write-protect a 3.5-inch diskette by sliding its write-protect tab to the open position and a 5.25-inch diskette by placing an adhesive label over its write-protect notch.

XMM

Abbreviation for extended memory manager, a utility that allows application programs and operating environments to use extended memory in accordance with the XMS. See also **conventional memory**, **EMM**, **expanded memory**, **extended memory**, and **memory manager**.

XMS

Abbreviation for eXtended Memory Specification. See also **EMS**, **extended memory**, and **memory manager**.

ZIF

Acronym for zero insertion force. Some computers use ZIF sockets and connectors to allow devices such as the microprocessor chip to be installed or removed with no stress applied to the device.



Index

A

- asset tag number
 - assigning, 2-6
 - deleting, 2-6
- Asset Tag option, 4-11
- Asset Tag utility, 2-6
- asset tag utility, 2-6
- assistance, technical, 1-7
- autoconfiguration
 - parallel port, B-3
 - serial ports, 4-9, B-2

B

- backup devices, C-1
- Boot Sequence options, 4-7
- booting the computer system, 4-7
- built-in SCSI controller, 1-2, 1-3

C

- cache
 - secondary, 1-1
- cautions, xi
- CD-ROM drive, 1-3

- cleaning
 - accessories, C-3
 - drives, C-4
 - internal components, C-2
 - solutions, C-3
 - system exterior, C-3
 - tools, C-3

- COM port designations, 4-9, B-1

- computer
 - booting, 4-7
 - cleaning, C-3
 - features, 1-1
 - front-panel indicators, 1-4
 - physical specifications, A-3

- connectors
 - back panel, B-2

- controls and indicators
 - front panel, 1-4

D

- data
 - backups, C-1
 - loss and recovery, C-2
 - recovery tools, C-2
- Date category, 4-5
- Dell Remote Assistant Card, 1-3
- Dell Server Assistant
 - using, 2-1
- diagnosing problems, 1-7

- diagnostics
 - diskette-based, 1-3
- DIMMs
 - about, 1-2
- Diskette Drive options, 4-5
- diskette drives
 - cleaning, C-4
 - head-cleaning kit, C-3
 - turning off built-in controller, 4-10
 - types, sizes, and capacities, 4-5
- Diskette First option, 4-7
- Diskette option, 4-10
- diskette-based diagnostics, 1-3
- drive activity indicator, 1-6
- drive online indicator, 1-6
- drives
 - specifications, A-2
- dual in-line memory modules. *See* DIMMs

E

- electromagnetic interference. *See* EMI
- electrostatic discharge. *See* ESD
- EMI, C-6
- environmental specifications, A-3
- error messages, 4-16
- ESD, vii, C-6
- expansion bus
 - specifications, A-1
- expansion cards
 - configuring, 5-1
 - conflict resolution, 5-8
 - locking and unlocking, 5-7
 - with diskette drive controller, 4-10
 - with ports, 4-9, B-2
- exterior cleaning of system, C-3

F

- features
 - system, 1-1
- front panel
 - controls and indicators, 1-4

G

- getting help, 1-7
- grounding strap, C-3

H

- hard disk. *See* drives; SCSI devices
- Hard Disk Only option, 4-7
- hard-disk drives
 - access indicator, 1-6
 - cleaning, C-4
 - data recovery, C-1
 - SCSI backplane indicator lights, 1-6
- help tools, 1-7

I

- indicators
 - front-panel, 1-6
 - SCSI backplane board, 1-6
- Industry-Standard Architecture. *See* ISA
- interrupt request. *See* IRQ
- IntranetWare
 - approved drives, 3-22
 - error codes, 3-23, 3-24
 - installing, 3-16
 - installing IntranetWare Support Pack 5, 3-19
 - installing SCSI drivers, 3-13
 - optimizing performance, 3-23

IntranetWare (*continued*)
troubleshooting, 3-23
using a CD-ROM, 3-23
using startup.ncf and autoexec.ncf,
3-19, 3-21
IRQ line, B-2

K

key combinations
System Setup program, 4-3
keyboard
cleaning, C-3
keyboard connector
about, B-6
illustrated, B-2
pin assignments, B-6
Keyboard Errors option, 4-7
keylock
illustrated, 1-6
keys
<Ctrl><Alt><Enter>, 4-2
<F1>, 4-16
<F2>, 4-16
System Setup program, 4-3

L

Level 2 Cache option, 4-10
LPT port designations, B-1

M

Manufacturing Test Report, 4-1
memory
about, 1-2
error messages after installing, 4-16
specifications, A-1

messages
help messages on System Setup
screens, 4-2
invalid configuration information, 4-1
prompt to enter the System Setup
program, 4-1
microprocessor
features, 1-1
specifications, A-1
speeds, 1-1, 4-6
types supported, 1-1, A-1
upgrade kit, 1-2
monitor
cleaning, C-3
mouse connector
about, B-5
illustrated, B-2
pin assignments, B-7
Mouse option, 4-9

N

notational conventions, xi
Num Lock option, 4-6

O

operating systems, 1-4

P

Parallel Mode option, 4-10
parallel port
about, B-1
compatibility, 4-9
configuring, B-3
designations, B-1
IRQ line, B-2
pin assignments, B-4

- parallel port connector
 - about, B-4
 - illustrated, B-2
 - pin assignments, B-5
- Parallel Port option, 4-9
- Password Status option, 4-8
- password. *See* setup password; system password
- PCI expansion cards
 - Resource Configuration Utility, 5-1
- Peripheral Component Interconnect. *See* PCI
- physical specifications, A-3
- Plug and Play expansion cards
 - Resource Configuration Utility, 5-1
- ports
 - adding expansion cards with, 4-9, B-2
 - autoconfiguration, 4-9
 - designations, 4-9, B-1
 - illustrated, B-2
 - specifications, A-2
- power
 - button, 1-5
 - indicator, 1-5
 - protection devices, C-9
 - specifications, A-3
 - surges and spikes, C-8
- power source interruptions
 - preventing, C-8
- Primary SCSI and Secondary SCSI option, 4-10
- problem solving, 1-7
- Processors 1 and 2, 4-6

R

- radio frequency interference. *See* RFI
- recovering data
 - tools, C-2

- regulatory notices, D-2
- Resource Configuration Utility
 - about, 5-1
 - Advanced menu, 5-6
 - exiting, 5-6
 - Main menu, 5-3
 - making selections, 5-2
 - online instructions, 5-2
 - program diskettes, 5-2
 - resolving resource conflicts, 5-8
 - starting, 5-2
 - Steps in Configuring Your Computer menu, 5-4
 - system board options, 5-4
 - System Board Options screen, 5-5
 - when to run, 5-2
- resource conflicts
 - resolving, 5-8
- return policy, E-3
- RFI, C-6

S

- safety instructions
 - for preventing ESD, vii
 - general, v
 - health considerations, vi
- Scan Sequence option, 4-8
- SCSI, 3-1
- SCSI backplane board
 - about, 1-3
 - indicators, 1-6
- SCSI devices
 - CD-ROM drive, 1-3
- SCSI disk utilities, 3-3
- SCSI drivers
 - included with system, 3-1
 - installing for IntranetWare, 3-13
- SCSI host adapters
 - integrated Adaptec AIC-7860, 1-3

- SCSISelect utility
 - advanced host adapter settings, 3-7
 - boot device settings, 3-6
 - default settings, 3-3
 - exiting, 3-3
 - installing for IntranetWare, 3-13
 - SCSI device/configuration settings, 3-6
 - starting, 3-2
 - using menus, 3-2
 - using the SCSI disk utilities, 3-3
- security
 - See also* setup password; system password
 - system, 1-7
- security, System Setup program, 4-9
- Serial Port 1 and Serial Port 2 options, 4-9
- serial port 1 connector
 - about, B-3
 - illustrated, B-2
 - pin assignments, B-3
- serial port 2 connector
 - about, B-3
 - illustrated, B-2
 - pin assignments, B-3
- serial ports
 - about, B-1
 - autoconfiguration, 4-9
 - configuring, B-2
 - designations, B-1
 - disabling and enabling, 4-9
 - IRQ lines, B-2
 - pin assignments, B-4
- Server Assistant CD
 - about, 2-1
 - booting system from, 2-1
 - installing video drivers from, 2-4
 - main menu, 2-2
 - utility partition, 2-2
- server management features, 1-3
- service, 1-7
- Service Tag option, 4-11
- setup password
 - assigning, 4-15
 - changing or deleting an existing password, 4-15
 - disabling a forgotten password, 4-16
 - using, 4-15
 - viewing current status, 4-9
- Setup Password option, 4-9
- small computer system interface. *See* SCSI
- SMB connector
 - about, B-9
 - illustrated, B-2
 - pin assignments, B-9
- Speaker option, 4-10
- specifications
 - system, A-1
- support, 1-7
- surge protector
 - preventing power source interruptions, C-9
- system board
 - features, 1-2
 - options in Resource Configuration Utility, 5-4
- system configuration information, 4-1, 5-1
- system data option, 4-10
- system environment
 - altitude, C-5
 - corrosion, C-6
 - dust, C-5
 - EMI and RFI, C-6
 - ESD, C-6
 - humidity, C-5
 - magnetism, C-7
 - power source, C-8
 - shock and vibration, C-7
 - temperature, C-4
- system features, 1-1
- System Memory option, 4-10

- system password
 - about, 4-11, 4-14
 - assigning, 4-11
 - changing or deleting an existing password, 4-14
 - disabling a forgotten password, 4-16
 - entering a wrong or incomplete password, 4-13
 - risk of not using password, 4-11
 - using to secure your system, 4-13
 - viewing current status, 4-8
- System Password option, 4-8
- system security, 1-7
- System Setup program
 - about, 4-1
 - BIOS version, 4-2
 - copying or printing screen information, 4-1
 - disabling a forgotten password, 4-16
 - entering, 4-2
 - error messages, 4-16
 - help messages, 4-2
 - key functions, 4-3
 - navigation keys, 4-3
 - options, 4-5
 - Resource Configuration Utility, 4-1, 5-1
 - screens, 4-4
 - setup password feature, 4-14
 - system configuration information, 4-1
 - system password feature, 4-11
 - using the program, 4-3
- system specifications, A-1

T

- tape drives
 - backing up data, C-1
 - cleaning, C-4
- technical assistance, 1-7
- Time category, 4-5
- tools
 - cleaning, C-3

- troubleshooting
 - general, 1-7
 - IntranetWare, 3-23
 - Windows NT, 3-13

U

- uninterruptible power supply. *See* UPS
- UPS, C-9
- utility partition, 2-2

V

- video
 - connector pin assignments, B-8
 - drivers for Windows NT, 2-4
 - specifications, A-2
 - subsystem, 1-2
- video connector
 - about, B-7
 - illustrated, B-2
 - pin assignments, B-8
- Video Memory option, 4-11

W

- warnings, xi
- warranty information, x, E-1
- Windows NT
 - installing video drivers, 2-5
 - removing a host adapter, 3-11
 - swapping a host adapter, 3-12
 - troubleshooting, 3-13
 - updating drivers, 3-10

Y

- year 2000 statement of compliance, E-4

Free Manuals Download Website

<http://myh66.com>

<http://usermanuals.us>

<http://www.somanuals.com>

<http://www.4manuals.cc>

<http://www.manual-lib.com>

<http://www.404manual.com>

<http://www.luxmanual.com>

<http://aubethermostatmanual.com>

Golf course search by state

<http://golfingnear.com>

Email search by domain

<http://emailbydomain.com>

Auto manuals search

<http://auto.somanuals.com>

TV manuals search

<http://tv.somanuals.com>