



# Cisco SFS 7008P InfiniBand Server Switch Installation and Configuration Note

---

**Product number:** *PID=78-17434-01 Rev. A0*

This installation and configuration note describes how to install and configure the Cisco SFS 7008P switch. This publication contains these sections:

- [Safety Overview, page 2](#)
- [Parts List, page 2](#)
- [Required Tools, Equipment, and Personnel, page 2](#)
- [Before You Install, page 3](#)
- [Installing the Cisco SFS 7008P Switch into a Rack, page 6](#)
- [Troubleshooting, page 20](#)
- [Translated Safety Warnings, page 21](#)
- [Obtaining Documentation, page 27](#)
- [Documentation Feedback, page 27](#)
- [Cisco Product Security Overview, page 28](#)
- [Obtaining Technical Assistance, page 29](#)
- [Obtaining Additional Publications and Information, page 31](#)



---

**Corporate Headquarters:**  
**Cisco Systems, Inc., 170 West Tasman Drive, San Jose, CA 95134-1706 USA**

© 2006 Cisco Systems, Inc. All rights reserved.

# Safety Overview

Safety warnings appear throughout this publication in procedures that may harm you if performed incorrectly. A warning symbol precedes each warning statement.



Warning

---

## IMPORTANT SAFETY INSTRUCTIONS

**This warning symbol means danger. You are in a situation that could cause bodily injury. Before you work on any equipment, be aware of the hazards involved with electrical circuitry and be familiar with standard practices for preventing accidents. Use the statement number provided at the end of each warning to locate its translation in the translated safety warnings that accompanied this device.** Statement 1071

## SAVE THESE INSTRUCTIONS

---

## Parts List

The following items are included in your SFS 7008 package:

- Chassis with TopSpin OS v2.5.0 preloaded
- 2 Serial Cable Kits
  - Serial Cable
  - Serial cable document
  - DB-9 connector male to RJ-45
  - DB-9 connector female to RJ-45
  - MX-9-1 roll-over cable
- Power cord for each power supply
- Bezel
- Parts bag
- Regulation and Compliance Statement
- 1 year warranty package (Cisco PN 83-1190-01)

## Required Tools, Equipment, and Personnel

In addition to the accessories provided with the switch, you should have the following:

- A #2 Phillips screw driver
- Screws (not provided) to attach the mounting brackets to the rack
- Any associated mounting clips to secure the brackets to your rack (two for each rail of the rack)
- A rack with enough clearance for the Cisco SFS 7008P switch and cables.

- Three people to complete the installation (highly recommended). The Cisco SFS 7008P switch chassis weighs up to 106 pounds fully loaded.

## Before You Install

Before you begin the installation, do the following:

- Make sure that you have the right cables and sufficient ventilation.
- Open the Cisco SFS 7008P package and remove the chassis, rack brackets, parts bag, and documentation from the box. Remove the packaging from around the chassis. After you have removed the straps, lift the box up and away from the switch and pallet. Do not cut the packaging, as you could damage the switch. Save the box and packaging.
- Prepare a management workstation, such as a PC or laptop running a terminal program with a rollover M/F DB-9 serial cable (included).

## Verifying Basic Hardware

If you have not purchased a fully loaded chassis with high-availability components installed, verify that you have the minimum components necessary to run the chassis. Specific components in the Cisco SFS 7008P switch (see [Figure 1](#) and [Figure 2](#)) have interdependencies on other components.

Check for basic hardware by following these steps:

- 
- Step 1** Verify that you have at least one management interface module installed in slot 15 at the back of the unit. (See [Figure 1](#).) Slot 15 is paired with the Fabric Controller in slot 11. (See [Figure 2](#).)

**Figure 1** *Back of Unit*

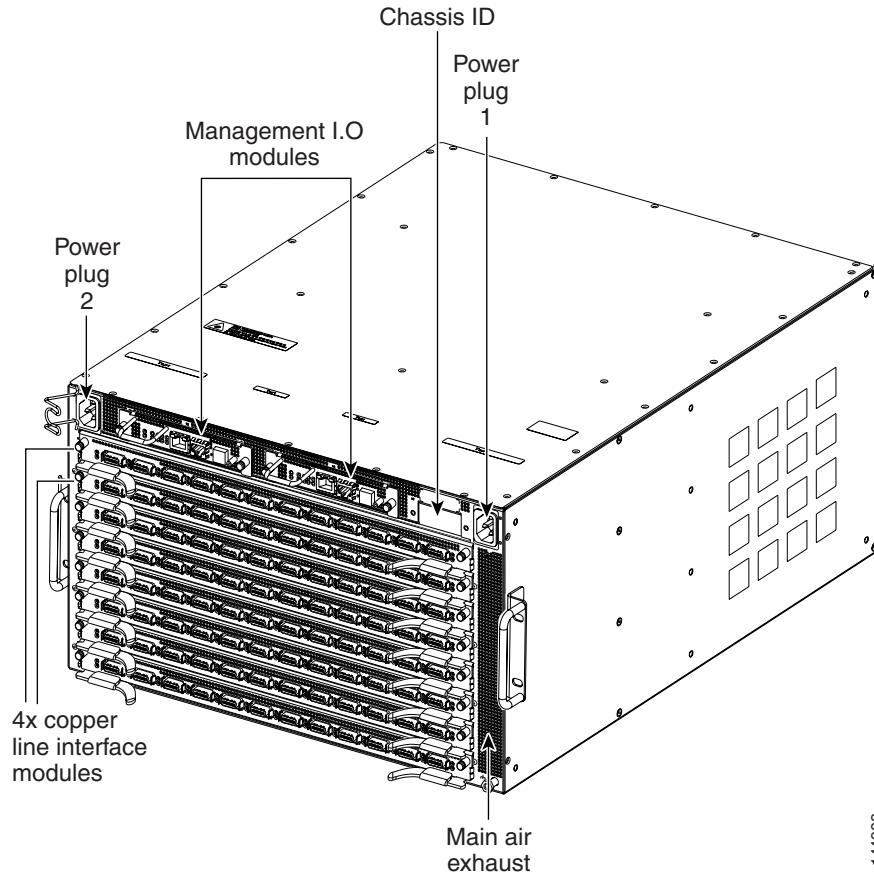

144988

- Step 2** Verify that you have a Chassis ID module installed. (See [Figure 1](#)).
- Step 3** Verify that you have a Fabric Controller installed in the Core slot (see slot 11 in [Figure 2](#)). A second Fabric Controller module (installed in slot 12) is not required for the chassis to function, but is required to have a non-blocking fabric.

**Figure 2** Cisco SFS 7008P Switch Front View Without Bezel

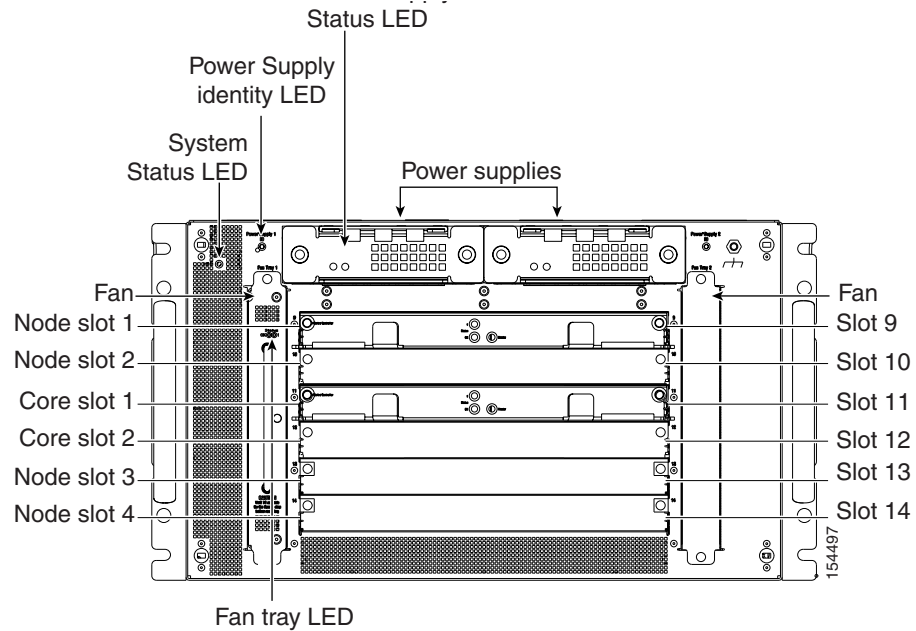

- Step 4** Verify that you have at least one power supply installed. (See [Figure 2](#).)
- Step 5** Verify that you have at least one fan module installed. (See [Figure 2](#).)
- Step 6** Verify that you have at least one fabric module installed in one of the node slots. The node slots are 9, 10, 13 and 14. (See [Figure 2](#).)
- Step 7** Verify that you have two LIMs installed for each fabric module in the node slots. See [Figure 3](#) for an example of the connections between the LIMs and the fabric modules in the node slots:

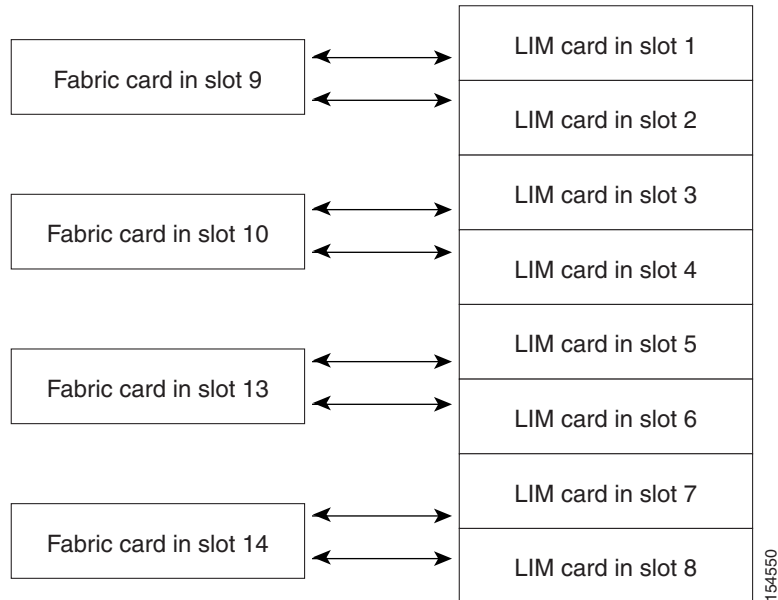
**Figure 3** LIM and Fabric Module Connections

## Installing the Cisco SFS 7008P Switch into a Rack

This section describes how to install the Cisco SFS 7008P switch in an equipment rack. If you purchased the custom Cisco SFS 7008P switch shelf, follow the directions in the *Cisco SFS 7008 InfiniBand Server Switch Hardware Installation Guide*. To mount the Cisco SFS 7008P switch chassis in an industry-standard rack, follow these steps:

**Step 1** Install a shelf for the chassis as shown in [Figure 4](#), if you have not already done so.

The shelf must support the weight of the chassis, which can be up to 106 pounds if all possible components are installed.

**Figure 4**      **Install Appropriate Shelf**

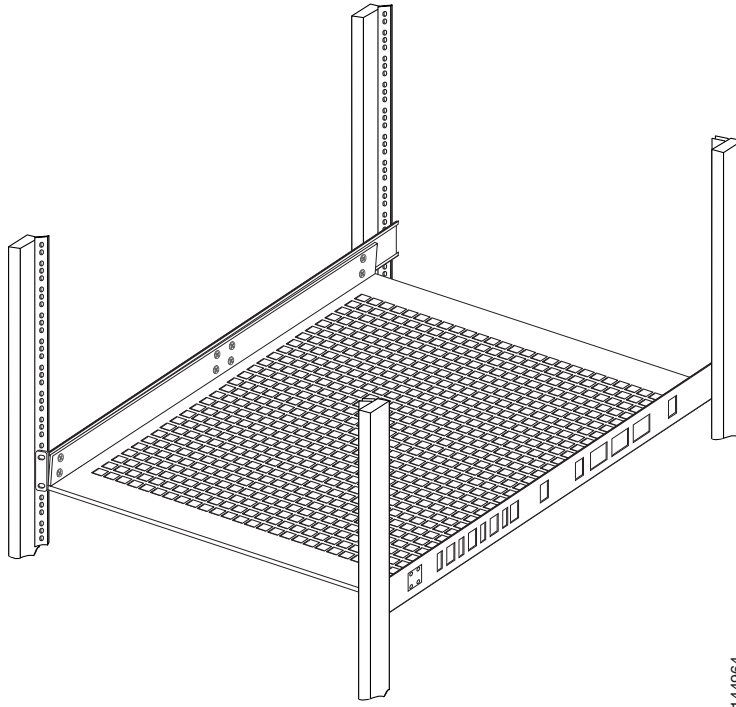

144964

**Step 2**      Ground yourself using an approved ground wrist-strap.

**Step 3**      Determine the direction that the switch will be installed and justified in the rack.

The direction that the switch will be justified determines which set of mounting brackets need to be removed in the next step.

**Step 4**      Remove one set of mounting brackets, as shown in [Figure 5](#):

- If the switch will be justified toward the bezel-side in the rack, then unscrew the mounting brackets from the port-side of the switch.
- If the switch will be justified toward the port-side in the rack, then unscrew the mounting brackets from the bezel-side of the switch.

**Figure 5**      *Unscrew Extra Mounting Brackets from the Chassis*

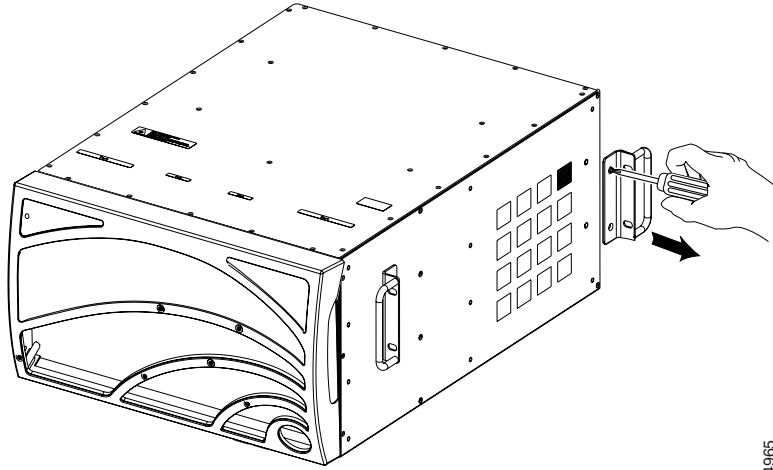

**Step 5**      Separate the mounting brackets from the chassis when all screws have been loosened.

**Step 6**      With 2 or 3 people working together, lift the switch into the rack as shown in [Figure 6](#).

**Figure 6**      *Chassis Set onto Shelf*

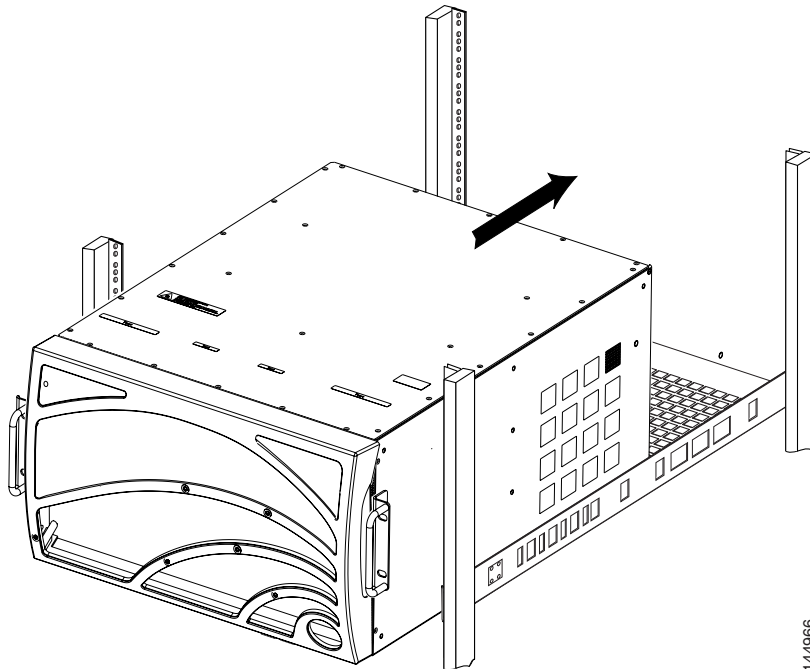

**Step 7**      Push the chassis into the rack until the mounting brackets are flush with the rails.

**Step 8**      Use screws that fit your rack to attach both mounting brackets to the rack posts.



## Installing Optional High-Availability Components

If you purchased a High-Availability (HA) package, install the following components:

- Redundant Power Supply; see the power supply locations in [Figure 7](#). Install the second power supply according to the directions in the *Power Supply Module Installation Guide* in the package.

**Figure 7** Power Supplies and Fans Located in the Front of the Unit with the Bezel Removed

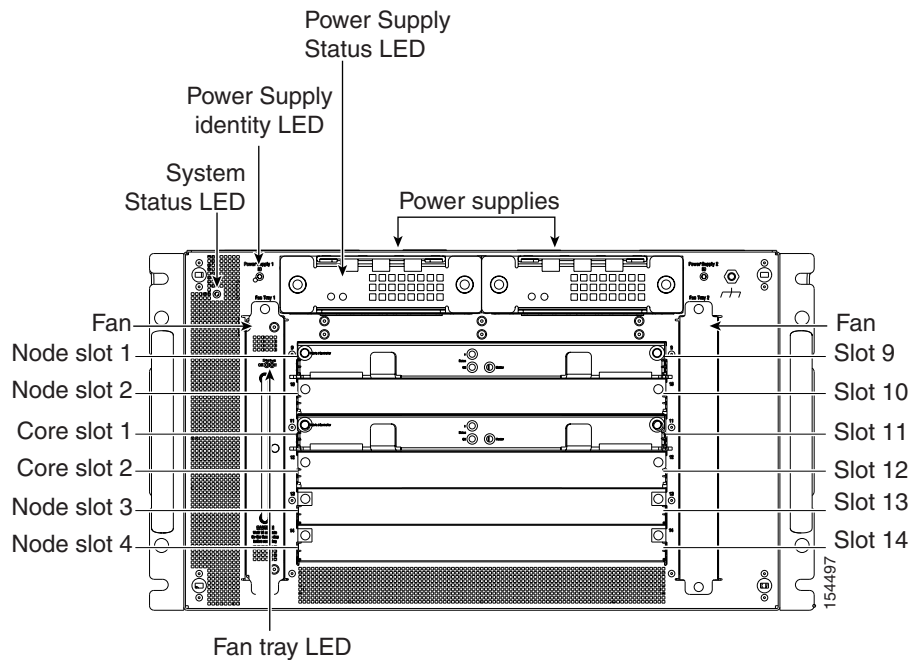

- Redundant Fan Tray; see the fan locations in [Figure 7](#). Install the second fan according to the *Fan Module Installation Guide* in the package.
- Redundant Management Interface Module; see the location of the Management I/O Modules in [Figure 8](#). Install the second I/O Module according to the directions in the *Management Interface Module Installation Guide* in the package.

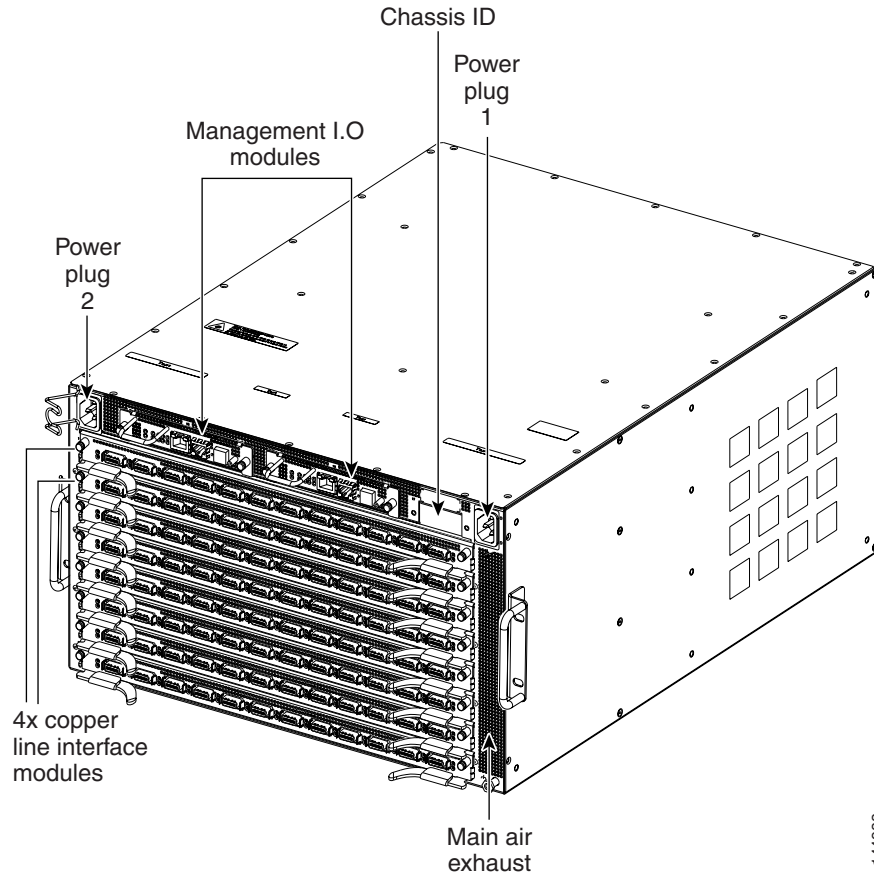
**Figure 8** Management I/O Modules Located in the Back of the Unit

## Configuring and Connecting Host Channel Expansion Card for IBM BladeCenter

This section briefly describes configuring your InfiniBand host. Download the configuration software and an integrated suite of drivers including IPoIB, SRP, SDP, uDAPL and MPI from the Cisco Software Center at this URL:

<http://www.cisco.com/public/sw-center>

Install the Host Channel Expansion Card for IBM BladeCenter by doing the following:

- 
- Step 1** Power down the host system following proper grounding procedures.
  - Step 2** Unpack the HCA module and insert it into an open 64-bit PCI or PCI-X slot.
  - Step 3** Power on the host system.
- 

## Installing Host Channel Expansion Card Linux Drivers

Make sure your Linux kernel is supported. See [www.cisco.com](http://www.cisco.com) for a list of supported versions.

To install the Host Channel Expansion Card for IBM BladeCenter drivers after you have installed the HCA Expansion Card, follow these steps:

- 
- Step 1** Locate your downloaded software directory.
- Step 2** Open a terminal or graphic window and access the top-level directory.
- Step 3** Execute the command `./tsinstall` in a terminal window.

```
# cdmount ./tsinstall
```

This program automatically detects the available kernel and installs the appropriate drivers as RPM packages. By default, the files are saved in the `/usr/local/cisco` directory.

- Step 4** Configure the IPoIB driver by assigning an IP address to interface `ib0` and/or `ib1`, which corresponds to the two HCA ports. IPoIB drivers load when the interfaces are used for the first time. To assign `ib` interfaces, enter `ifconfig ib# ip address netmask netmask`.

This example configures one HCA:

```
# ifconfig ib0 192.168.0.1 netmask 255.255.255.0
#
# ifconfig ib1 192.168.1.1 netmask 255.255.255.0
#
```

This example configures two HCAs:

```
# ifconfig ib0 192.168.0.1 netmask 255.255.255.0
#
# ifconfig ib1 192.168.1.1 netmask 255.255.255.0
#
# ifconfig ib2 192.168.2.1 netmask 255.255.255.0
#
# ifconfig ib3 192.168.3.1 netmask 255.255.255.0
#
```

- Step 5** Merge `ib0` and `ib1` for port-to-port redundancy, if desired.
- Step 6** (Optional) Configure MPI by following these steps:
- Make sure that your connections to the HCA uses port 1 of the first HCA. MPI requires the use of HCA 1, port 1.
  - Set up `rsh` or `ssh` on two nodes so that you can run commands between a remote and local node without entering a login or password. This is required to use the MPI protocol.
  - Either add paths to your environment `PATH`:

```
/usr/local/cisco/mpi/mpich/bin
```

```
/usr/local/cisco/bin
```

or

Add directories to your `PATH` variable. For example:

```
export PATH=$PATH:/usr/local/cisco
```

- Step 7** Configure all other drivers, including `SDP`.
-

## Installing Non-WHQL Host Channel Expansion Card Drivers on a Windows 2000 Server (BoIB and non-BoIB)

The SFS 7008 chassis has Topspin operating system version 2.5.0 preloaded. **DRIVERS TOO? OR DOWNLOAD?? IN STEP 4, THE SDK COMES UP - WHERE DID THAT COME FROM?**

To install Windows drivers after you have installed the HCA Expansion Card, follow these steps:

- Step 1** Log on to your Windows 2000 host.  
A Found New Hardware alert appears (see [Figure 9](#)).

**Figure 9 Found New Hardware Alert**

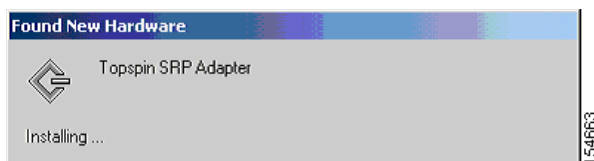

- Step 2** Ignore the alert.  
The Found New Hardware Wizard window opens (see [Figure 10](#)).

**Figure 10 Found New Hardware Wizard WIZARD.TIF**



- Step 3** Click **Cancel**.



**Note** This wizard may not appear immediately. When the wizard does appear, click **Cancel**.

- Step 4** Run **Topspin-ib-W2k-releaseNumber.exe**.  
The InfiniBand SDK Setup window opens (see [Figure 11](#)).

**Figure 11** *InfiniBand SDK Setup Window*



- Step 5** Click **Next**.  
The End User License Agreement window opens.
- Step 6** Click the **I Agree to the terms listed above** radio button, and then click **Next**.  
The Product Information window appears.
- Step 7** Click **Next**.  
The Ready to Install window opens.
- Step 8** Click **Next**.  
The installation executes. The Installation Complete window appears when the installation completes.
- Step 9** Click **Finish**.  
The system prompts you to reboot. If you have not previously installed host drivers on this system, you do not need to reboot.
- Step 10** Click **Yes**.  
Your host reboots.

## Installing Host Channel Expansion Card Windows 2003 Drivers

If you have not already done so, download an integrated suite of HCA drivers including IPoIB, SRP, SDP, uDAPL and MPI from the Cisco Software Center at this URL:

<http://www.cisco.com/public/sw-center>

To install the Windows 2003 drivers, follow these steps:

- Step 1** Log on to your Windows 2003 host.
- Step 2** **HOW DID SW GET ON MY COMPUTER?HOW DO I START THIS???????????????**  
The Product Install window appears (see [Figure 12](#)).

**Figure 12** *Product Install Window*

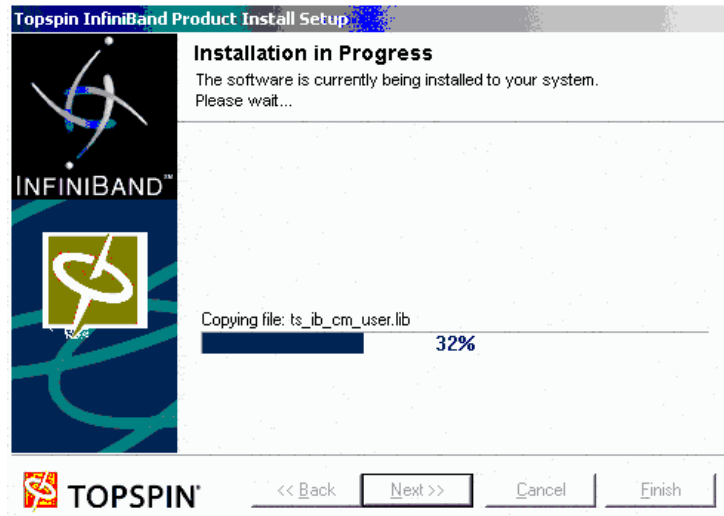

- Step 3** Click **Next**.  
The End User License Agreement appears.
- Step 4** Click the **I Agree to the terms listed above** radio button, and then click **Next** to continue.  
The Product Information window appears.
- Step 5** Click **Next**.  
The Installation in Progress window appears with the status of the installation (see [Figure 13](#)).

**Figure 13**      **Installation Status**

A Windows driver dialog box appears. This dialog box explains that the new drivers do not contain a Windows signature. Although the drivers are not digitally signed, they are tested using the Microsoft HCT suite. WHQL submission materials are available per request (CAB files, etc.).

**Step 6**      Click **Continue Anyway** (Figure 14) each time the Windows Logo testing dialog box appears.

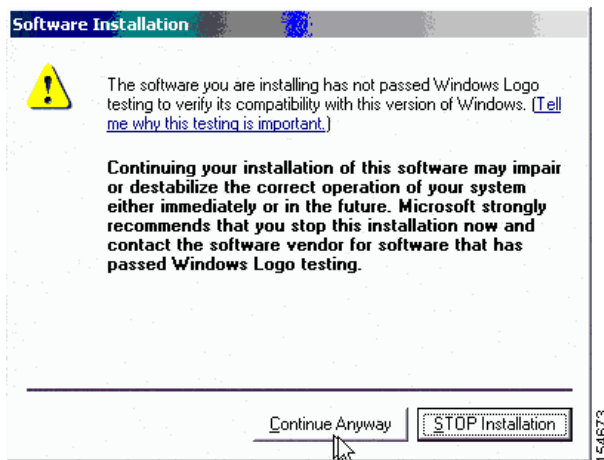
**Figure 14**      **Testing Dialog Box**

The driver installation notice shown in Figure 15 appears for each host channel adapter you have installed.

**Step 7**      Click **Yes** in the Driver Installation Notice dialog window. (See Figure 15.)

**Figure 15** *Driver Installation Notice*

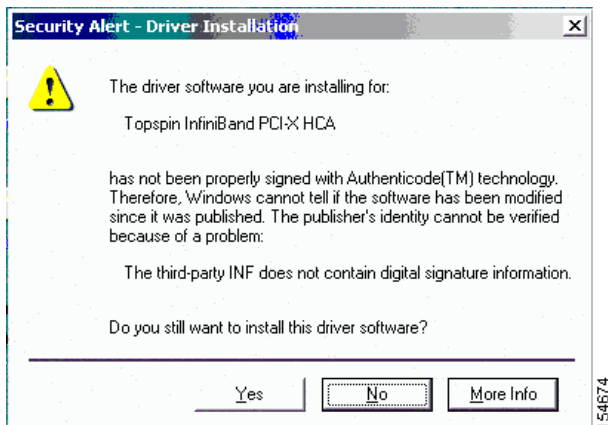

**Step 8** **Important:** Ignore the Found New Hardware Wizard (see Figure 16) when it appears because it will continue without user intervention. This window appears three times (twice for the IPOIB and once for SRP).

**Figure 16** *Ignore the Found New Hardware Wizard Windows*



**Step 9** Click **Finish**.

**Step 10** Reboot the server.

- a. In Windows, click **Start > Shutdown**.  
You see the screen in Figure 17.
- b. Select **Restart** from the drop-down menu(see Figure 17).
- c. Optionally, enter a reason for the system reboot in the **Comment** field (see Figure 17), if your server requires it.
- d. Click **OK**.  
The system reboots and new driver installation is complete.

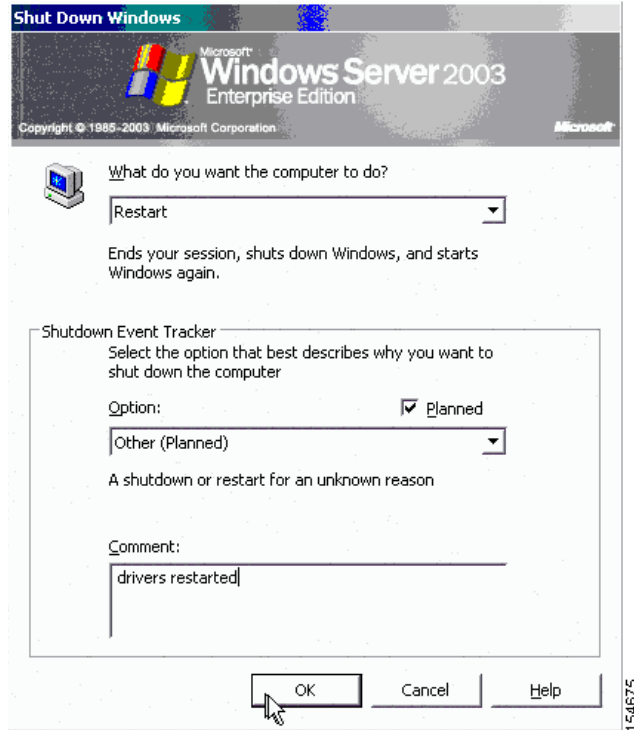

**Figure 17** Restarting Windows Server

## Installing WHQL Drivers on a Windows 2000 or 2003 Server (BoIB and non-BoIB)

WHQL drivers are packaged in a .ZIP file. To install WHQL drivers, see the documentation at <http://www.cisco.com>. **THERE IS NOTHING HERE??!!**

## Launching the SFS Chassis Manager (Optional)

SFS Chassis Manager is a web-based GUI that can be used to manage a single InfiniBand chassis from a Web browser. SFS Chassis Manager supports the following browsers:

- Microsoft Internet Explorer version 6
- Netscape Navigator version 6
- Mozilla version 1.4

To launch SFS Chassis Manager, follow these steps:

- Step 1** Type the Management IP address of your switch in the address field of your browser and press **Enter**. A login window opens. (See [Figure 18](#).)

**Figure 18 SFS Chassis Manager Log-In Window**



- Step 2** Enter your username and password in the log-in window and click **Login** .  
SFS Chassis Manager loads in your browser window as shown in Figures 19 and 20.

**Figure 19 SFS Chassis Manager Opening (Rear View)**

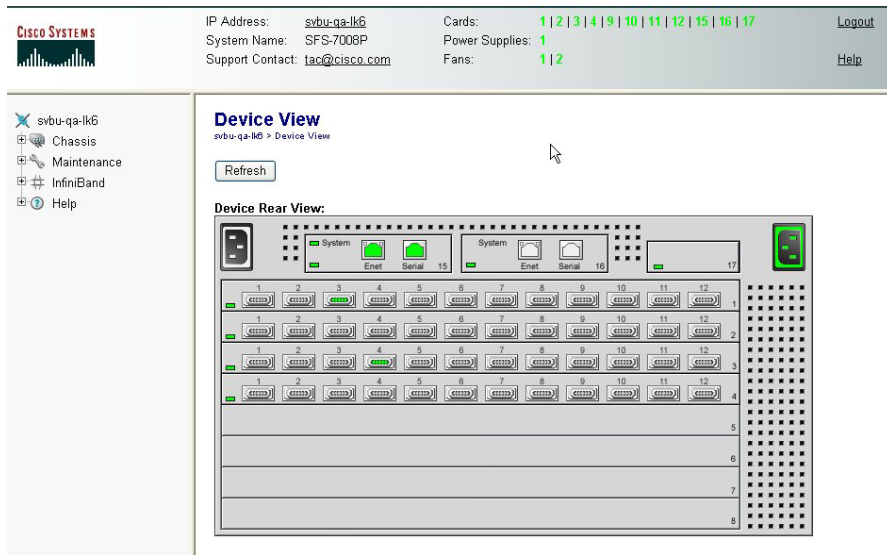

154610

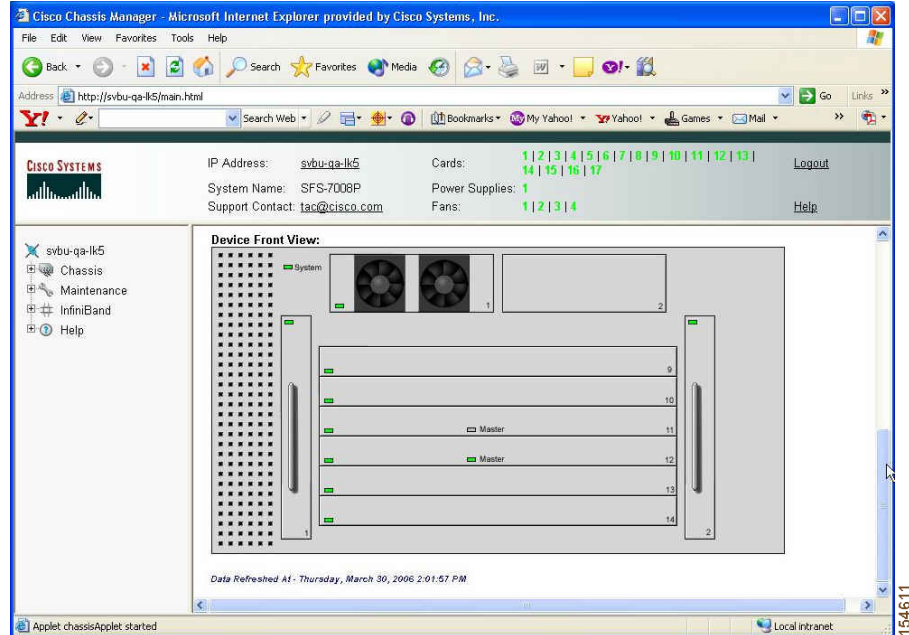
**Figure 20 SFS Chassis Manager Opening (Front View)**

154611

## Installing the SFS Element Manager GUI (Optional)

For more information regarding the SFS Element Manager, see the *Cisco SFS 7000 Series Product Family Element Manager User Guide*.

To install Element Manager, follow these steps:

- 
- Step 1** Ensure that you have sufficient system resources. You need the following:
- 32 MB free RAM
  - 50 MB disk space and 50MB additional temporary space during installation
  - 300 MHz processor
  - 800 x 600 screen resolution, 16-bit color depth
- Step 2** Download the Element Manager software. To download the latest software, access the Cisco Software Center at this URL:
- <http://www.cisco.com/public/sw-center>**
- Step 3** Locate the appropriate install file.
- Linux/install\_linux\_ia64.bin
  - Linux/install\_linux\_x86.bin
  - Windows/install\_x86.exe
  - Solaris/install\_solaris\_sparc.bin

- Step 4** Run the installation wizard:
- a. On Windows, double-click **install.exe**.  
On Solaris and Linux systems, enter **sh ./install\_yourOS.bin**.
  - b. Follow the onscreen instructions. Enter location and preference information as requested by the installation program.
- Step 5** Start the SFS Element Manager by following these steps:
- a. On Windows platforms, click **Programs -> Cisco SFS Element Manager -> Cisco SFS EM**.  
On Linux platforms, change to the installation directory and run SFS Element Manager with **./CiscoEM**.
  - b. When prompted to enter a device name, enter the DNS host name or IP address of the Cisco SFS 7008P switch, and community string for the unrestricted user. The default community string for the unrestricted user is **secret**.
- 

## Troubleshooting

For all customers, partners, resellers, and distributors who hold valid Cisco service contracts, Cisco Technical Support provides 24-hour-a-day, award-winning technical assistance. The Cisco Technical Support Website on Cisco.com features extensive online support resources. In addition, Cisco Technical Assistance Center (TAC) engineers provide telephone support. If you do not hold a valid Cisco service contract, contact your reseller.

## Cisco Technical Support Website

The Cisco Technical Support Website provides online documents and tools for troubleshooting and resolving technical issues with Cisco products and technologies. The website is available 24 hours a day, 365 days a year, at this URL:

<http://www.cisco.com/techsupport>

Access to all tools on the Cisco Technical Support Website requires a Cisco.com user ID and password. If you have a valid service contract but do not have a user ID or password, you can register at this URL:

<http://tools.cisco.com/RPF/register/register.do>



**Note**

Use the Cisco Product Identification (CPI) tool to locate your product serial number before submitting a web or phone request for service. You can access the CPI tool from the Cisco Technical Support Website by clicking the **Tools & Resources** link under Documentation & Tools. Choose **Cisco Product Identification Tool** from the Alphabetical Index drop-down list, or click the **Cisco Product Identification Tool** link under Alerts & RMAs. The CPI tool offers three search options: by product ID or model name; by tree view; or for certain products, by copying and pasting **show** command output. Search results show an illustration of your product with the serial number label location highlighted. Locate the serial number label on your product and record the information before placing a service call.

---

## Submitting a Service Request

Using the online TAC Service Request Tool is the fastest way to open S3 and S4 service requests. (S3 and S4 service requests are those in which your network is minimally impaired or for which you require product information.) After you describe your situation, the TAC Service Request Tool provides recommended solutions. If your issue is not resolved using the recommended resources, your service request is assigned to a Cisco TAC engineer. The TAC Service Request Tool is located at <http://www.cisco.com/techsupport/servicerequest>.

For S1 or S2 service requests or if you do not have Internet access, contact the Cisco TAC by telephone. (S1 or S2 service requests are those in which your production network is down or severely degraded.) Cisco TAC engineers are assigned immediately to S1 and S2 service requests to help keep your business operations running smoothly.

To open a service request by telephone, use one of the following numbers:

Asia-Pacific: +61 2 8446 7411 (Australia: 1 800 805 227)

EMEA: +32 2 704 55 55

USA: 1 800 553-2447

For a complete list of Cisco TAC contacts, see <http://www.cisco.com/techsupport/contacts>.

## Definitions of Service Request Severity

To ensure that all service requests are reported in a standard format, Cisco has established severity definitions.

Severity 1 (S1)—Your network is “down,” or there is a critical impact to your business operations. You and Cisco will commit all necessary resources around the clock to resolve the situation.

Severity 2 (S2)—Operation of an existing network is severely degraded, or significant aspects of your business operation are negatively affected by inadequate performance of Cisco products. You and Cisco will commit full-time resources during normal business hours to resolve the situation.

Severity 3 (S3)—Operational performance of your network is impaired, but most business operations remain functional. You and Cisco will commit resources during normal business hours to restore service to satisfactory levels.

Severity 4 (S4)—You require information or assistance with Cisco product capabilities, installation, or configuration. There is little or no effect on your business operations.

## Translated Safety Warnings

Safety warnings appear throughout this publication in procedures that may harm you if performed incorrectly. A warning symbol precedes each warning statement.



Warning

**IMPORTANT SAFETY INSTRUCTIONS**

This warning symbol means danger. You are in a situation that could cause bodily injury. Before you work on any equipment, be aware of the hazards involved with electrical circuitry and be familiar with standard practices for preventing accidents. Use the statement number provided at the end of each warning to locate its translation in the translated safety warnings that accompanied this device. Statement 1071

**SAVE THESE INSTRUCTIONS**

Waarschuwing

**BELANGRIJKE VEILIGHEIDSINSTRUCTIES**

Dit waarschuwingssymbool betekent gevaar. U verkeert in een situatie die lichamelijk letsel kan veroorzaken. Voordat u aan enige apparatuur gaat werken, dient u zich bewust te zijn van de bij elektrische schakelingen betrokken risico's en dient u op de hoogte te zijn van de standaard praktijken om ongelukken te voorkomen. Gebruik het nummer van de verklaring onderaan de waarschuwing als u een vertaling van de waarschuwing die bij het apparaat wordt geleverd, wilt raadplegen.

**BEWAAR DEZE INSTRUCTIES**

Varoitus

**TÄRKEITÄ TURVALLISUUSOHJEITA**

Tämä varoitusmerkki merkitsee vaaraa. Tilanne voi aiheuttaa ruumiillisia vammoja. Ennen kuin käsittelet laitteistoa, huomioi sähköpiirien käsittelemiseen liittyvät riskit ja tutustu onnettomuuksien yleisiin ehkäisytapoihin. Turvallisuusvaroitusten käännökset löytyvät laitteen mukana toimitettujen käännettyjen turvallisuusvaroitusten joukosta varoitusten lopussa näkyvien lausuntonumeroiden avulla.

**SÄILYTÄ NÄMÄ OHJEET**

Attention

**IMPORTANTES INFORMATIONS DE SÉCURITÉ**

Ce symbole d'avertissement indique un danger. Vous vous trouvez dans une situation pouvant entraîner des blessures ou des dommages corporels. Avant de travailler sur un équipement, soyez conscient des dangers liés aux circuits électriques et familiarisez-vous avec les procédures couramment utilisées pour éviter les accidents. Pour prendre connaissance des traductions des avertissements figurant dans les consignes de sécurité traduites qui accompagnent cet appareil, référez-vous au numéro de l'instruction situé à la fin de chaque avertissement.

**CONSERVEZ CES INFORMATIONS**

Warnung

**WICHTIGE SICHERHEITSHINWEISE**

Dieses Warnsymbol bedeutet Gefahr. Sie befinden sich in einer Situation, die zu Verletzungen führen kann. Machen Sie sich vor der Arbeit mit Geräten mit den Gefahren elektrischer Schaltungen und den üblichen Verfahren zur Vorbeugung vor Unfällen vertraut. Suchen Sie mit der am Ende jeder Warnung angegebenen Anweisungsnummer nach der jeweiligen Übersetzung in den übersetzten Sicherheitshinweisen, die zusammen mit diesem Gerät ausgeliefert wurden.

**BEWAHREN SIE DIESE HINWEISE GUT AUF.**

**Avvertenza    IMPORTANTI ISTRUZIONI SULLA SICUREZZA**

Questo simbolo di avvertenza indica un pericolo. La situazione potrebbe causare infortuni alle persone. Prima di intervenire su qualsiasi apparecchiatura, occorre essere al corrente dei pericoli relativi ai circuiti elettrici e conoscere le procedure standard per la prevenzione di incidenti. Utilizzare il numero di istruzione presente alla fine di ciascuna avvertenza per individuare le traduzioni delle avvertenze riportate in questo documento.

**CONSERVARE QUESTE ISTRUZIONI****Advarsel    VIKTIGE SIKKERHETSINSTRUKSJONER**

Dette advarselssymbolet betyr fare. Du er i en situasjon som kan føre til skade på person. Før du begynner å arbeide med noe av utstyret, må du være oppmerksom på farene forbundet med elektriske kretser, og kjenne til standardprosedyrer for å forhindre ulykker. Bruk nummeret i slutten av hver advarsel for å finne oversettelsen i de oversatte sikkerhetsadvarslene som fulgte med denne enheten.

**TA VARE PÅ DISSE INSTRUKSJONENE****Aviso    INSTRUÇÕES IMPORTANTES DE SEGURANÇA**

Este símbolo de aviso significa perigo. Você está em uma situação que poderá ser causadora de lesões corporais. Antes de iniciar a utilização de qualquer equipamento, tenha conhecimento dos perigos envolvidos no manuseio de circuitos elétricos e familiarize-se com as práticas habituais de prevenção de acidentes. Utilize o número da instrução fornecido ao final de cada aviso para localizar sua tradução nos avisos de segurança traduzidos que acompanham este dispositivo.

**GUARDE ESTAS INSTRUÇÕES****¡Advertencia!    INSTRUCCIONES IMPORTANTES DE SEGURIDAD**

Este símbolo de aviso indica peligro. Existe riesgo para su integridad física. Antes de manipular cualquier equipo, considere los riesgos de la corriente eléctrica y familiarícese con los procedimientos estándar de prevención de accidentes. Al final de cada advertencia encontrará el número que le ayudará a encontrar el texto traducido en el apartado de traducciones que acompaña a este dispositivo.

**GUARDE ESTAS INSTRUCCIONES****Varning!    VIKTIGA SÄKERHETSANVISNINGAR**

Denna varningssignal signalerar fara. Du befinner dig i en situation som kan leda till personskada. Innan du utför arbete på någon utrustning måste du vara medveten om farorna med elkretsar och känna till vanliga förfaranden för att förebygga olyckor. Använd det nummer som finns i slutet av varje varning för att hitta dess översättning i de översatta säkerhetsvarningar som medföljer denna anordning.

**SPARA DESSA ANVISNINGAR**

**Figyelem FONTOS BIZTONSÁGI ELOÍRÁSOK**

Ez a figyelmeztető jel veszélyre utal. Sérülésveszélyt rejtő helyzetben van. Mielott bármely berendezésen munkát végezte, legyen figyelemmel az elektromos áramkörök okozta kockázatokra, és ismerkedjen meg a szokásos balesetvédelmi eljárásokkal. A kiadványban szereplő figyelmeztetések fordítása a készülékhez mellékelte biztonsági figyelmeztetések között található; a fordítás az egyes figyelmeztetések végén látható szám alapján kereshető meg.

**ORIZZE MEG EZEKET AZ UTASÍTÁSOKAT!****Предупреждение ВАЖНЫЕ ИНСТРУКЦИИ ПО СОБЛЮДЕНИЮ ТЕХНИКИ БЕЗОПАСНОСТИ**

Этот символ предупреждения обозначает опасность. То есть имеет место ситуация, в которой следует опасаться телесных повреждений. Перед эксплуатацией оборудования выясните, каким опасностям может подвергаться пользователь при использовании электрических цепей, и ознакомьтесь с правилами техники безопасности для предотвращения возможных несчастных случаев. Воспользуйтесь номером заявления, приведенным в конце каждого предупреждения, чтобы найти его переведенный вариант в переводе предупреждений по безопасности, прилагаемом к данному устройству.

**СОХРАНИТЕ ЭТИ ИНСТРУКЦИИ****警告 重要的安全性说明**

此警告符号代表危险。您正处于可能受到严重伤害的工作环境中。在您使用设备开始工作之前，必须充分意识到触电的危险，并熟练掌握防止事故发生的标准工作程序。请根据每项警告结尾提供的声明号码来找到此设备的安全性警告说明的翻译文本。

请保存这些安全性说明

**警告 安全上の重要な注意事項**

「危険」の意味です。人身事故を予防するための注意事項が記述されています。装置の取り扱い作業を行うときは、電気回路の危険性に注意し、一般的な事故防止策に留意してください。警告の各国語版は、各注意事項の番号を基に、装置に付属の「Translated Safety Warnings」を参照してください。

これらの注意事項を保管しておいてください。

**주의 중요 안전 지침**

이 경고 기호는 위험을 나타냅니다. 작업자가 신체 부상을 일으킬 수 있는 위험한 환경에 있습니다. 장비에 작업을 수행하기 전에 전기 회로와 관련된 위험을 숙지하고 표준 작업 관례를 숙지하여 사고를 방지하십시오. 각 경고의 마지막 부분에 있는 경고문 번호를 참조하여 이 장치와 함께 제공되는 번역된 안전 경고문에서 해당 번역문을 찾으십시오.

이 지시 사항을 보관하십시오.



**Aviso INSTRUÇÕES IMPORTANTES DE SEGURANÇA**

Este símbolo de aviso significa perigo. Você se encontra em uma situação em que há risco de lesões corporais. Antes de trabalhar com qualquer equipamento, esteja ciente dos riscos que envolvem os circuitos elétricos e familiarize-se com as práticas padrão de prevenção de acidentes. Use o número da declaração fornecido ao final de cada aviso para localizar sua tradução nos avisos de segurança traduzidos que acompanham o dispositivo.

**GUARDE ESTAS INSTRUÇÕES****Advarsel VIGTIGE SIKKERHEDSANVISNINGER**

Dette advarselssymbol betyder fare. Du befinder dig i en situation med risiko for legemeskade. Før du begynder arbejde på udstyr, skal du være opmærksom på de involverede risici, der er ved elektriske kredsløb, og du skal sætte dig ind i standardprocedurer til undgåelse af ulykker. Brug erklæringsnummeret efter hver advarsel for at finde oversættelsen i de oversatte advarsler, der fulgte med denne enhed.

**GEM DISSE ANVISNINGER****تحذير****إرشادات الأمان الهامة**

يوضح رمز التحذير هذا وجود خطر. وهذا يعني أنك متواجد في مكان قد ينتج عنه التعرض للإصابات. قبل بدء العمل، احذر مخاطر التعرض للصدمات الكهربائية وكن على علم بالإجراءات القياسية للحيلولة دون وقوع أي حوادث. استخدم رقم البيان الموجود في آخر كل تحذير لتحديد مكان ترجمته داخل تحذيرات الأمان المترجمة التي تأتي مع الجهاز. قم بحفظ هذه الإرشادات

**Upozorenje VAŽNE SIGURNOSNE NAPOMENE**

Ovaj simbol upozorenja predstavlja opasnost. Nalazite se u situaciji koja može prouzročiti tjelesne ozljede. Prije rada s bilo kojim uređajem, morate razumjeti opasnosti vezane uz električne sklopove, te biti upoznati sa standardnim načinima izbjegavanja nesreća. U prevedenim sigurnosnim upozorenjima, priloženima uz uređaj, možete prema broju koji se nalazi uz pojedino upozorenje pronaći i njegov prijevod.

**SAČUVAJTE OVE UPUTE****Upozornění DŮLEŽITÉ BEZPEČNOSTNÍ POKYNY**

Tento upozorňující symbol označuje nebezpečí. Jste v situaci, která by mohla způsobit nebezpečí úrazu. Před prací na jakémkoliv vybavení si uvědomte nebezpečí související s elektrickými obvody a seznamte se se standardními opatřeními pro předcházení úrazům. Podle čísla na konci každého upozornění vyhledejte jeho překlad v přeložených bezpečnostních upozorněních, která jsou přiložena k zařízení.

**USCHOVEJTE TYTO POKYNY**

## Προειδοποίηση ΣΗΜΑΝΤΙΚΕΣ ΟΔΗΓΙΕΣ ΑΣΦΑΛΕΙΑΣ

Αυτό το προειδοποιητικό σύμβολο σημαίνει κίνδυνο. Βρίσκεστε σε κατάσταση που μπορεί να προκαλέσει τραυματισμό. Πριν εργαστείτε σε οποιοδήποτε εξοπλισμό, να έχετε υπόψη σας τους κινδύνους που σχετίζονται με τα ηλεκτρικά κυκλώματα και να έχετε εξοικειωθεί με τις συνήθεις πρακτικές για την αποφυγή ατυχημάτων. Χρησιμοποιήστε τον αριθμό δήλωσης που παρέχεται στο τέλος κάθε προειδοποίησης, για να εντοπίσετε τη μετάφρασή της στις μεταφρασμένες προειδοποιήσεις ασφαλείας που συνοδεύουν τη συσκευή.

ΦΥΛΑΞΤΕ ΑΥΤΕΣ ΤΙΣ ΟΔΗΓΙΕΣ

## הזרה

**הוראות בטיחות חשובות**

סימן הזהרה זה מסמל סכנה. אתה נמצא במצב העלול לגרום לפציעה. לפני שתעבוד עם ציוד כלשהו, עליך להיות מודע לסכנות הכרוכות במעגלים חשמליים ולהכיר את הנהלים המקובלים למניעת תאונות. השתמש במספר ההוראה המסופק בסופה של כל אזהרה כדי לאתר את התרגום באזהרות הבטיחות המתורגמות שמצורפות להתקן.

**שמור הוראות אלה**

## Opomena

**ВАЖНИ БЕЗБЕДНОСНИ НАПАТСТВИЈА**

Симболот за предупредување значи опасност. Се наоѓате во ситуација што може да предизвика телесни повреди. Пред да работите со опремата, бидете свесни за ризикот што постои кај електричните кола и треба да ги познавате стандардните постапки за спречување на несреќни случаи. Искористете го бројот на изјавата што се наоѓа на крајот на секое предупредување за да го најдете неговиот период во преведените безбедносни предупредувања што се испорачани со уредот.

ЧУВАЈТЕ ГИ ОБИЕ НАПАТСТВИЈА

## Ostrzeżenie

**WAŻNE INSTRUKCJE DOTYCZĄCE BEZPIECZEŃSTWA**

Ten symbol ostrzeżenia oznacza niebezpieczeństwo. Zachodzi sytuacja, która może powodować obrażenia ciała. Przed przystąpieniem do prac przy urządzeniach należy zapoznać się z zagrożeniami związanymi z układami elektrycznymi oraz ze standardowymi środkami zapobiegania wypadkom. Na końcu każdego ostrzeżenia podano numer, na podstawie którego można odszukać tłumaczenie tego ostrzeżenia w dołączonym do urządzenia dokumencie z tłumaczeniami ostrzeżeń.

**NINIEJSZE INSTRUKCJE NALEŻY ZACHOWAĆ**

## Upozornenie

**DÔLEŽITÉ BEZPEČNOSTNÉ POKYNY**

Tento varovný symbol označuje nebezpečenstvo. Nachádzate sa v situácii s nebezpečenstvom úrazu. Pred prácou na akomkoľvek vybavení si uvedomte nebezpečenstvo súvisiace s elektrickými obvodmi a oboznámte sa so štandardnými opatreniami na predchádzanie úrazom. Podľa čísla na konci každého upozornenia vyhľadajte jeho preklad v preložených bezpečnostných upozorneniach, ktoré sú priložené k zariadeniu.

**USCHOVAJTE SI TENTO NÁVOD**

# Obtaining Documentation

Cisco documentation and additional literature are available on Cisco.com. Cisco also provides several ways to obtain technical assistance and other technical resources. These sections explain how to obtain technical information from Cisco Systems.

## Cisco.com

You can access the most current Cisco documentation at this URL:

<http://www.cisco.com/techsupport>

You can access the Cisco website at this URL:

<http://www.cisco.com>

You can access international Cisco websites at this URL:

[http://www.cisco.com/public/countries\\_languages.shtml](http://www.cisco.com/public/countries_languages.shtml)

## Product Documentation DVD

The Product Documentation DVD is a comprehensive library of technical product documentation on a portable medium. The DVD enables you to access multiple versions of installation, configuration, and command guides for Cisco hardware and software products. With the DVD, you have access to the same HTML documentation that is found on the Cisco website without being connected to the Internet. Certain products also have .PDF versions of the documentation available.

The Product Documentation DVD is available as a single unit or as a subscription. Registered Cisco.com users (Cisco direct customers) can order a Product Documentation DVD (product number DOC-DOCDVD= or DOC-DOCDVD=SUB) from Cisco Marketplace at this URL:

<http://www.cisco.com/go/marketplace/>

## Ordering Documentation

Registered Cisco.com users may order Cisco documentation at the Product Documentation Store in the Cisco Marketplace at this URL:

<http://www.cisco.com/go/marketplace/>

Nonregistered Cisco.com users can order technical documentation from 8:00 a.m. to 5:00 p.m. (0800 to 1700) PDT by calling 1 866 463-3487 in the United States and Canada, or elsewhere by calling 011 408 519-5055. You can also order documentation by e-mail at [tech-doc-store-mkpl@external.cisco.com](mailto:tech-doc-store-mkpl@external.cisco.com) or by fax at 1 408 519-5001 in the United States and Canada, or elsewhere at 011 408 519-5001.

## Documentation Feedback

You can rate and provide feedback about Cisco technical documents by completing the online feedback form that appears with the technical documents on cisco.com.

You can submit comments about Cisco documentation by using the response card (if present) behind the front cover of your document or by writing to the following address:

Cisco Systems  
Attn: Customer Document Ordering  
170 West Tasman Drive  
San Jose, CA 95134-9883

We appreciate your comments.

## Cisco Product Security Overview

Cisco provides a free online Security Vulnerability Policy portal at this URL:

[http://www.cisco.com/en/US/products/products\\_security\\_vulnerability\\_policy.html](http://www.cisco.com/en/US/products/products_security_vulnerability_policy.html)

From this site, you will find information about how to:

- Report security vulnerabilities in Cisco products.
- Obtain assistance with security incidents that involve Cisco products.
- Register to receive security information from Cisco.

A current list of security advisories, security notices, and security responses for Cisco products is available at this URL:

<http://www.cisco.com/go/psirt>

To see security advisories, security notices, and security responses as they are updated in real time, you can subscribe to the Product Security Incident Response Team Really Simple Syndication (PSIRT RSS) feed. Information about how to subscribe to the PSIRT RSS feed is found at this URL:

[http://www.cisco.com/en/US/products/products\\_psirt\\_rss\\_feed.html](http://www.cisco.com/en/US/products/products_psirt_rss_feed.html)

## Reporting Security Problems in Cisco Products

Cisco is committed to delivering secure products. We test our products internally before we release them, and we strive to correct all vulnerabilities quickly. If you think that you have identified a vulnerability in a Cisco product, contact PSIRT:

- For Emergencies only—[security-alert@cisco.com](mailto:security-alert@cisco.com)

An emergency is either a condition in which a system is under active attack or a condition for which a severe and urgent security vulnerability should be reported. All other conditions are considered nonemergencies.

- For Nonemergencies—[psirt@cisco.com](mailto:psirt@cisco.com)

In an emergency, you can also reach PSIRT by telephone:

- 1 877 228-7302
- 1 408 525-6532



### Tip

We encourage you to use Pretty Good Privacy (PGP) or a compatible product (for example, GnuPG) to encrypt any sensitive information that you send to Cisco. PSIRT can work with information that has been encrypted with PGP versions 2.x through 9.x.

Never use a revoked or an expired encryption key. The correct public key to use in your correspondence with PSIRT is the one linked in the Contact Summary section of the Security Vulnerability Policy page at this URL:

[http://www.cisco.com/en/US/products/products\\_security\\_vulnerability\\_policy.html](http://www.cisco.com/en/US/products/products_security_vulnerability_policy.html)

The link on this page has the current PGP key ID in use.

If you do not have or use PGP, contact PSIRT at the aforementioned e-mail addresses or phone numbers before sending any sensitive material to find other means of encrypting the data.

---

## Obtaining Technical Assistance

Cisco Technical Support provides 24-hour-a-day award-winning technical assistance. The Cisco Technical Support & Documentation website on Cisco.com features extensive online support resources. In addition, if you have a valid Cisco service contract, Cisco Technical Assistance Center (TAC) engineers provide telephone support. If you do not have a valid Cisco service contract, contact your reseller.

## Cisco Technical Support & Documentation Website

The Cisco Technical Support & Documentation website provides online documents and tools for troubleshooting and resolving technical issues with Cisco products and technologies. The website is available 24 hours a day, at this URL:

<http://www.cisco.com/techsupport>

Access to all tools on the Cisco Technical Support & Documentation website requires a Cisco.com user ID and password. If you have a valid service contract but do not have a user ID or password, you can register at this URL:

<http://tools.cisco.com/RPF/register/register.do>



### Note

Use the Cisco Product Identification (CPI) tool to locate your product serial number before submitting a web or phone request for service. You can access the CPI tool from the Cisco Technical Support & Documentation website by clicking the **Tools & Resources** link under Documentation & Tools. Choose **Cisco Product Identification Tool** from the Alphabetical Index drop-down list, or click the **Cisco Product Identification Tool** link under Alerts & RMAs. The CPI tool offers three search options: by product ID or model name; by tree view; or for certain products, by copying and pasting **show** command output. Search results show an illustration of your product with the serial number label location highlighted. Locate the serial number label on your product and record the information before placing a service call.

---

## Submitting a Service Request

Using the online TAC Service Request Tool is the fastest way to open S3 and S4 service requests. (S3 and S4 service requests are those in which your network is minimally impaired or for which you require product information.) After you describe your situation, the TAC Service Request Tool provides recommended solutions. If your issue is not resolved using the recommended resources, your service request is assigned to a Cisco engineer. The TAC Service Request Tool is located at this URL:

<http://www.cisco.com/techsupport/servicerequest>

For S1 or S2 service requests, or if you do not have Internet access, contact the Cisco TAC by telephone. (S1 or S2 service requests are those in which your production network is down or severely degraded.) Cisco engineers are assigned immediately to S1 and S2 service requests to help keep your business operations running smoothly.

To open a service request by telephone, use one of the following numbers:

Asia-Pacific: +61 2 8446 7411 (Australia: 1 800 805 227)

EMEA: +32 2 704 55 55

USA: 1 800 553-2447

For a complete list of Cisco TAC contacts, go to this URL:

<http://www.cisco.com/techsupport/contacts>

## Definitions of Service Request Severity

To ensure that all service requests are reported in a standard format, Cisco has established severity definitions.

Severity 1 (S1)—An existing network is down, or there is a critical impact to your business operations. You and Cisco will commit all necessary resources around the clock to resolve the situation.

Severity 2 (S2)—Operation of an existing network is severely degraded, or significant aspects of your business operations are negatively affected by inadequate performance of Cisco products. You and Cisco will commit full-time resources during normal business hours to resolve the situation.

Severity 3 (S3)—Operational performance of the network is impaired, while most business operations remain functional. You and Cisco will commit resources during normal business hours to restore service to satisfactory levels.

Severity 4 (S4)—You require information or assistance with Cisco product capabilities, installation, or configuration. There is little or no effect on your business operations.

## Obtaining Additional Publications and Information

Information about Cisco products, technologies, and network solutions is available from various online and printed sources.

- The *Cisco Product Quick Reference Guide* is a handy, compact reference tool that includes brief product overviews, key features, sample part numbers, and abbreviated technical specifications for many Cisco products that are sold through channel partners. It is updated twice a year and includes the latest Cisco offerings. To order and find out more about the Cisco Product Quick Reference Guide, go to this URL:

<http://www.cisco.com/go/guide>

- Cisco Marketplace provides a variety of Cisco books, reference guides, documentation, and logo merchandise. Visit Cisco Marketplace, the company store, at this URL:

<http://www.cisco.com/go/marketplace/>

- *Cisco Press* publishes a wide range of general networking, training and certification titles. Both new and experienced users will benefit from these publications. For current Cisco Press titles and other information, go to Cisco Press at this URL:

<http://www.ciscopress.com>

- *Packet* magazine is the Cisco Systems technical user magazine for maximizing Internet and networking investments. Each quarter, Packet delivers coverage of the latest industry trends, technology breakthroughs, and Cisco products and solutions, as well as network deployment and troubleshooting tips, configuration examples, customer case studies, certification and training information, and links to scores of in-depth online resources. You can access Packet magazine at this URL:

<http://www.cisco.com/packet>

- *iQ Magazine* is the quarterly publication from Cisco Systems designed to help growing companies learn how they can use technology to increase revenue, streamline their business, and expand services. The publication identifies the challenges facing these companies and the technologies to help solve them, using real-world case studies and business strategies to help readers make sound technology investment decisions. You can access iQ Magazine at this URL:

<http://www.cisco.com/go/iqmagazine>

or view the digital edition at this URL:

<http://ciscoiq.texterity.com/ciscoiq/sample/>

- *Internet Protocol Journal* is a quarterly journal published by Cisco Systems for engineering professionals involved in designing, developing, and operating public and private internets and intranets. You can access the Internet Protocol Journal at this URL:

<http://www.cisco.com/ipj>

- Networking products offered by Cisco Systems, as well as customer support services, can be obtained at this URL:

<http://www.cisco.com/en/US/products/index.html>

- Networking Professionals Connection is an interactive website for networking professionals to share questions, suggestions, and information about networking products and technologies with Cisco experts and other networking professionals. Join a discussion at this URL:

<http://www.cisco.com/discuss/networking>

- World-class networking training is available from Cisco. You can view current offerings at this URL:

<http://www.cisco.com/en/US/learning/index.html>





---

This document is to be used in conjunction with the Cisco SFS 7000P Installation and Configuration Note.

CCSP, CCVP, the Cisco Square Bridge logo, Follow Me Browsing, and StackWise are trademarks of Cisco Systems, Inc.; Changing the Way We Work, Live, Play, and Learn, and iQuick Study are service marks of Cisco Systems, Inc.; and Access Registrar, Aironet, BPX, Catalyst, CCDA, CCDP, CCIE, CCIP, CCNA, CCNP, Cisco, the Cisco Certified Internetwork Expert logo, Cisco IOS, Cisco Press, Cisco Systems, Cisco Systems Capital, the Cisco Systems logo, Cisco Unity, Enterprise/Solver, EtherChannel, EtherFast, EtherSwitch, Fast Step, FormShare, GigaDrive, GigaStack, HomeLink, Internet Quotient, IOS, IP/TV, iQ Expertise, the iQ logo, iQ Net Readiness Scorecard, LightStream, Linksys, MeetingPlace, MGX, the Networkers logo, Networking Academy, Network Registrar, *Packet*, PIX, Post-Routing, Pre-Routing, ProConnect, RateMUX, ScriptShare, SlideCast, SMARTnet, The Fastest Way to Increase Your Internet Quotient, and TransPath are registered trademarks of Cisco Systems, Inc. and/or its affiliates in the United States and certain other countries.

All other trademarks mentioned in this document or Website are the property of their respective owners. The use of the word partner does not imply a partnership relationship between Cisco and any other company. (0601R)

© 2006 Cisco Systems, Inc. All rights reserved.

## Free Manuals Download Website

<http://myh66.com>

<http://usermanuals.us>

<http://www.somanuals.com>

<http://www.4manuals.cc>

<http://www.manual-lib.com>

<http://www.404manual.com>

<http://www.luxmanual.com>

<http://aubethermostatmanual.com>

Golf course search by state

<http://golfingnear.com>

Email search by domain

<http://emailbydomain.com>

Auto manuals search

<http://auto.somanuals.com>

TV manuals search

<http://tv.somanuals.com>