

Models QS12 & QS24

Modular Grills

Operating Instructions

050559-M



2/20/01

Complete this page for quick reference when service is required:

Taylor Distributor: _____

Address: _____

Phone: _____

Service: _____

Parts: _____

Date of Installation: _____

Information found on data plate:

Model Number: _____

Serial Number: _____

Electrical Specs: Voltage _____ Cycle _____

Phase _____

Maximum Fuse Size: _____ Amps

Minimum Wire Ampacity: _____ Amps

Part Number: _____

© February, 2001 Taylor
All rights reserved.
050559-M



*The word Taylor and the Crown design
are registered trademarks in the United States
of America and certain other countries.*

Taylor Company
a division of Carrier Commercial Refrigeration, Inc.
750 N. Blackhawk Blvd.
Rockton, IL 61072

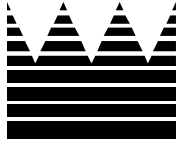

Table of Contents

Section 1	To the Installer	1
	Air Clearance	1
	Electrical Connections	1
	Ventilation and Clearance	2
	Leveling Procedures	2
Section 2	To the Operator	5
Section 3	Safety	6
Section 4	Operator Parts Identification	8
	QS12	8
	QS24	9
	QS12 Accessories	10
	QS24 Accessories	12
Section 5	Important: To the Operator	14
	Release Material (units with upper cook surfaces only)	14
	Temperature Controls	15
	Control Board	15
	Keypad and Display	15
	Operating Screen and Controls	15
	Maintenance Menu	17
	Maintenance Menu Flowchart	20
Section 6	Operating Procedures	21
	Opening Procedures	21
	Cooking Procedures	23
	Cleaning Between Product Runs	24
	Cleaning the Grease Tray Partition	25
	Closing Procedures	26
	Weekly Cleaning Procedures	28

Section 7	Troubleshooting Guide	29
Section 8	Warranty Explanation	31
	Parts	31
	Labor	31
Section 9	Parts List	32
	Wiring Diagrams	39

Note: Continuing research results in steady improvements; therefore, information in this manual is subject to change without notice.

© February, 2001 Taylor
All rights reserved.
050559-M



*The word Taylor and the Crown design
are registered trademarks in the United States
of America and certain other countries.*

Taylor Company
a division of Carrier Commercial Refrigeration, Inc.
750 N. Blackhawk Blvd.
Rockton, IL 61072

Ventilation and Clearance

To ensure proper operation of this appliance it must be installed so that the products of combustion are efficiently removed. Do not store anything on top of the grill.

Most service can be performed from the front of the grill. When inspecting heating elements, the unit must be disconnected and pulled out of the hood enclosure. Allow four feet in front of the appliance for this purpose.

Leveling Procedures

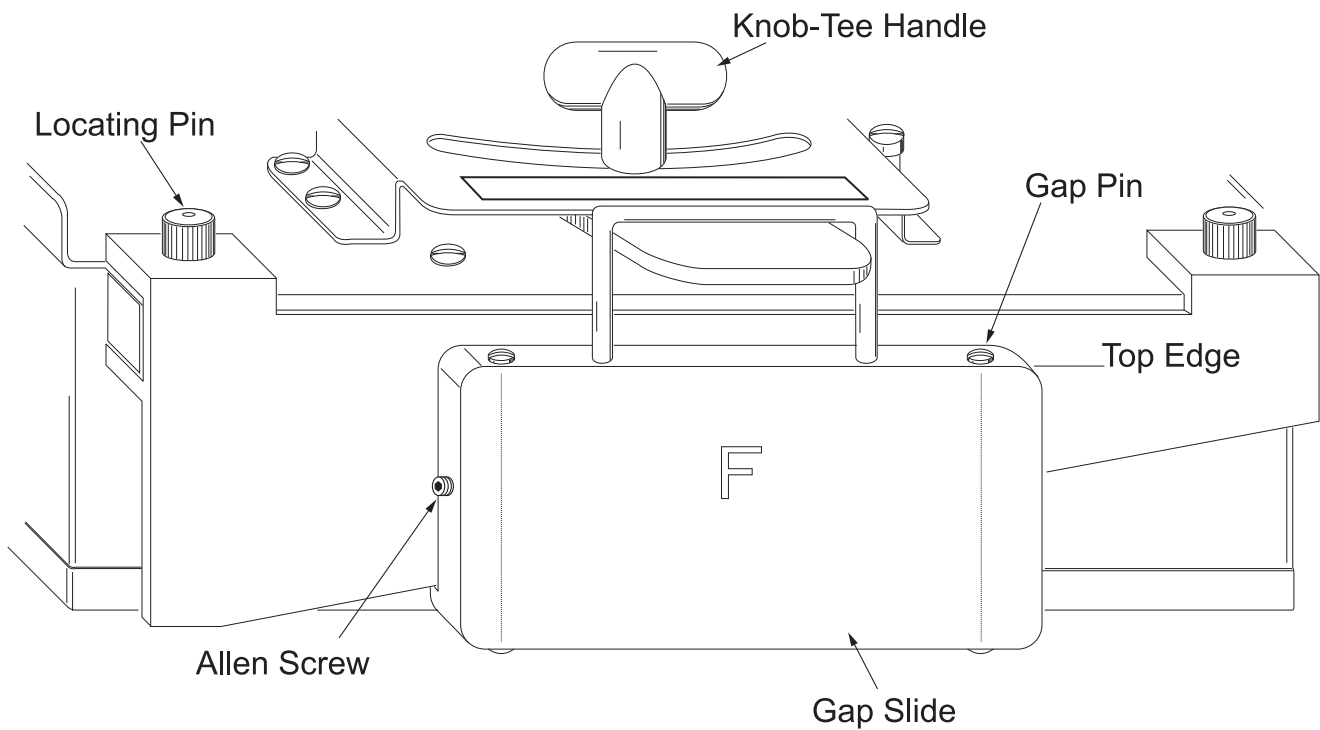

Figure 2

Step 1

The leveling adjustment needs to be performed while the grill is at operating temperature. Remove the cook surface shroud and release sheet.

Step 2

To allow adjustment of the gap pins, loosen the two set screws located on the side of the front and rear gap slide.

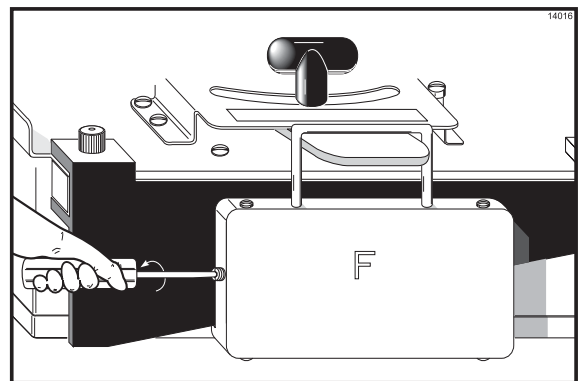

Figure 3

Step 3

Raise or lower both gap pins on the front gap slide until they are flush with the top edge of the gap slide. Repeat this step for the rear gap slide. Slide the gap slide to the right.

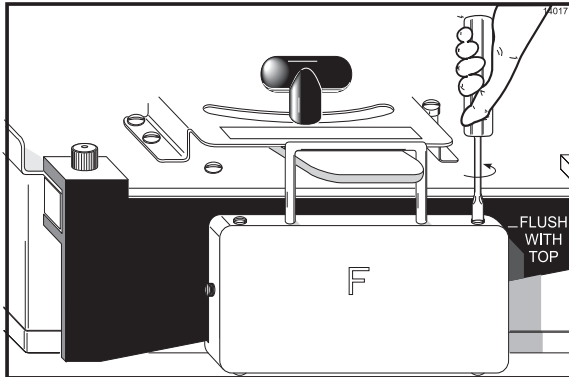

Figure 4

Step 4

For each cook surface requiring adjustment, place 4 gap blocks on the cook surface, approximately 2" (51 mm) in from each corner.

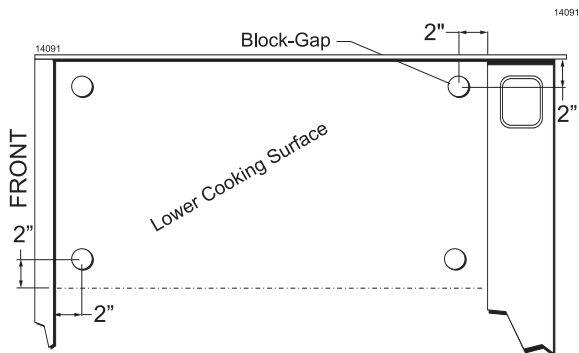

Figure 5

Step 5

Lower the cook surface assembly. Loosen and slowly move the T-handle to the left until the gap pins in the gap slides touch the cook surface, and tighten the T-handle.

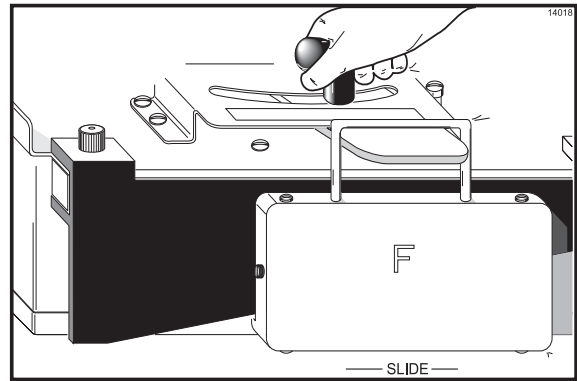

Figure 6

Step 6

Wearing proper protection, carefully attempt to raise the gap slide to evaluate which gap pin is in need of adjustment.

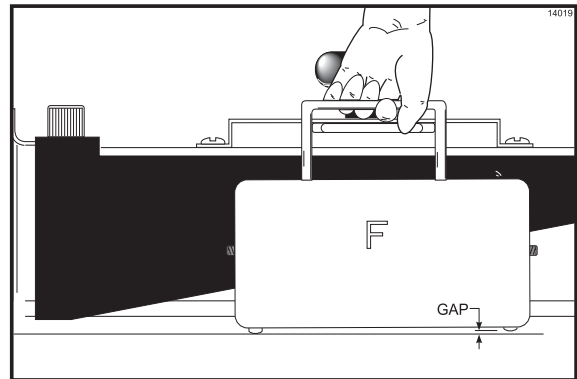

Figure 7

With the gap slide raised, slowly turn the gap pin needing adjustment until it makes contact with the cook surface. **Repeat these steps for both gap slides.**

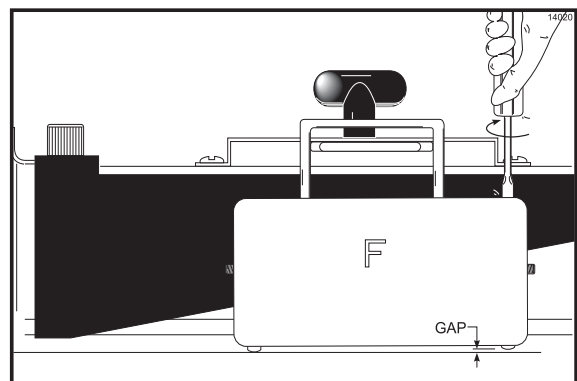

Figure 8

Step 7

Raise the upper cook surface and remove the four gap blocks.

Step 8

Lower the upper cook surface into the COOK position.

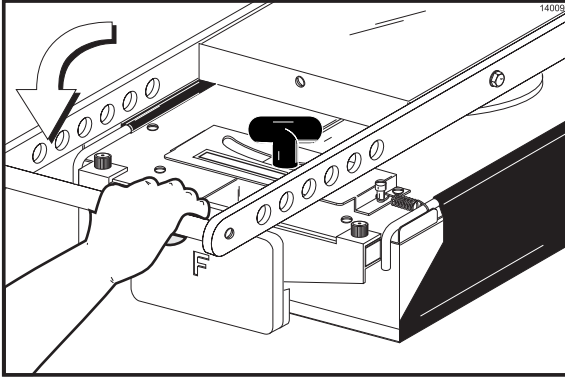

Figure 9

Step 9

Wearing proper protection, attempt to rock the cook surface assembly. Apply pressure on the locating pins at opposite corners to each other as shown in Figure 10.

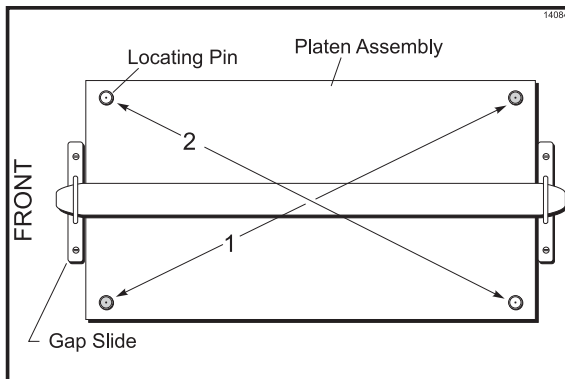

Figure 10

Step 10

If the unit rocks, split the adjustment for gap pins across the uneven corners, as shown in Figure 11.

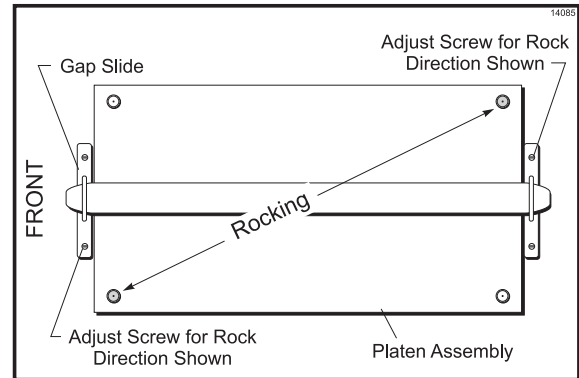

Figure 11

Step 11

After adjusting, verify the unit for stability.

Step 12

If all adjustments on the cook surface are correct, and no rocking occurs, tighten the two screws located on the side of the front and rear gap slides to lock all adjustments from moving.

It is highly recommended that the gap slides and the gap slide retainers be removed at least weekly for cleaning these parts and the cook surface shroud behind these parts.

These parts are easily removed by removing the locating pins and holding both parts, because they are not attached together, and pulling them from the cook surface.

Take the gap slides to the sink for cleaning. (Be sure to re-install the gap slides as they were removed, i.e., "F" front.) See Weekly Cleaning Procedures on page 28.

Section 2

To the Operator

The grill you have purchased has been carefully engineered and manufactured to provide dependable operation. This grill is designed to deliver “cook-to-order” menu items. The two-sided cooking method increases speed of service and assures safe product integrity.

The Taylor Grill, when properly operated and maintained, will produce a consistent quality product. Like all mechanical products, this machine will require cleaning and maintenance. A minimum amount of care and attention is necessary if the operating procedures in this manual are followed closely.

This Operator’s Manual should be read before operating or performing any maintenance on your equipment.

It is strongly recommended that all personnel responsible for the equipment’s operation and cleaning, review these procedures for proper training and assurance that no misunderstandings exist.

In the event that you require technical assistance, please contact your local authorized Taylor Distributor.



■ If the crossed out wheeled bin symbol is affixed to this product, it signifies that this product is compliant with the EU Directive as well as other similar legislation in effect after August 13, 2005. Therefore, it must be collected separately after its use is completed, and cannot be disposed as unsorted municipal waste.

The user is responsible for returning the product to the appropriate collection facility, as specified by your local code.

For additional information regarding applicable local laws, please contact the municipal facility and/or local distributor.

We at Taylor are deeply concerned about the safety of the operator when he or she comes in contact with the grill and its parts. Taylor has gone to extreme efforts to design and manufacture built-in safety features to protect both you and the service technician. As an example, warning labels have been attached to the grill to further point out safety precautions to the operator.

To Operate Safely:



DO NOT operate the grill without reading this operator's manual. This manual should be kept in a safe place for future reference.



This equipment is provided with a grounding lug that is to be properly attached to the rear of the frame by the authorized installer. The installation location is marked by the equipotential bonding symbol (5021 of IEC 60417-1) on the removable panel and the frame.



- **DO NOT** operate the grill unless it is properly grounded.
- **DO NOT** use the cord if it is frayed.
- **DO NOT** attempt any repairs unless the power supply to the grill has been disconnected.
- **DO NOT** operate the grill unless all service panels are restrained with screws.
- Stationary appliances which are not equipped with a power cord and a plug or other device to disconnect the appliance from the power source must have an all-pole disconnecting device with a contact gap of at least 3 mm installed in the external installation.

Failure to follow these instructions may result in electrocution. Contact your local Taylor Distributor for authorized service.





Grill clearance must be maintained at least 3" (76 mm) from all combustible materials (0" to non-combustible materials). Failure to comply could result in a fire hazard.



This grill must be placed on a level surface. Failure to comply may result in personal injury or equipment damage.



DO NOT use a water jet to clean or rinse the grill. Failure to follow this instruction may result in the following:

-  serious electrical shock
-  burns from hot steam
-  liquid collecting inside the grill and destroying electrical components.



- **DO NOT** prepare or remove product without proper equipment.
- **DO NOT** allow untrained personnel to operate this grill.
- **USE EXTREME CAUTION** when cleaning the grill.

Failure to follow these instructions may result in severe burns from high temperatures.



Taylor recommends Sizzle® Grill Bun and Toaster Cleaner, a Kay Chemical® product. Sizzle® is an alkaline detergent and is not environmentally harmful. Take caution to protect eyes, lungs, and all parts of the body from potential harm. See the Kay Chemical® MSDS for further details.

DO NOT slide the grill with the legs attached. Failure to follow this instruction may damage the grill.

DO NOT obstruct air intake and discharge openings: 4" (102 mm) minimum air space on the bottom and 3" (76 mm) at the rear of the unit. Failure to comply will affect grill performance and may cause component damage.

NOISE LEVEL: Airborne noise emission does not exceed 70 dB(A) when measured at a distance of 1.0 meter from the surface of the machine and at a height of 1.6 meters from the floor.

Section 4

Operator Parts Identification

QS12

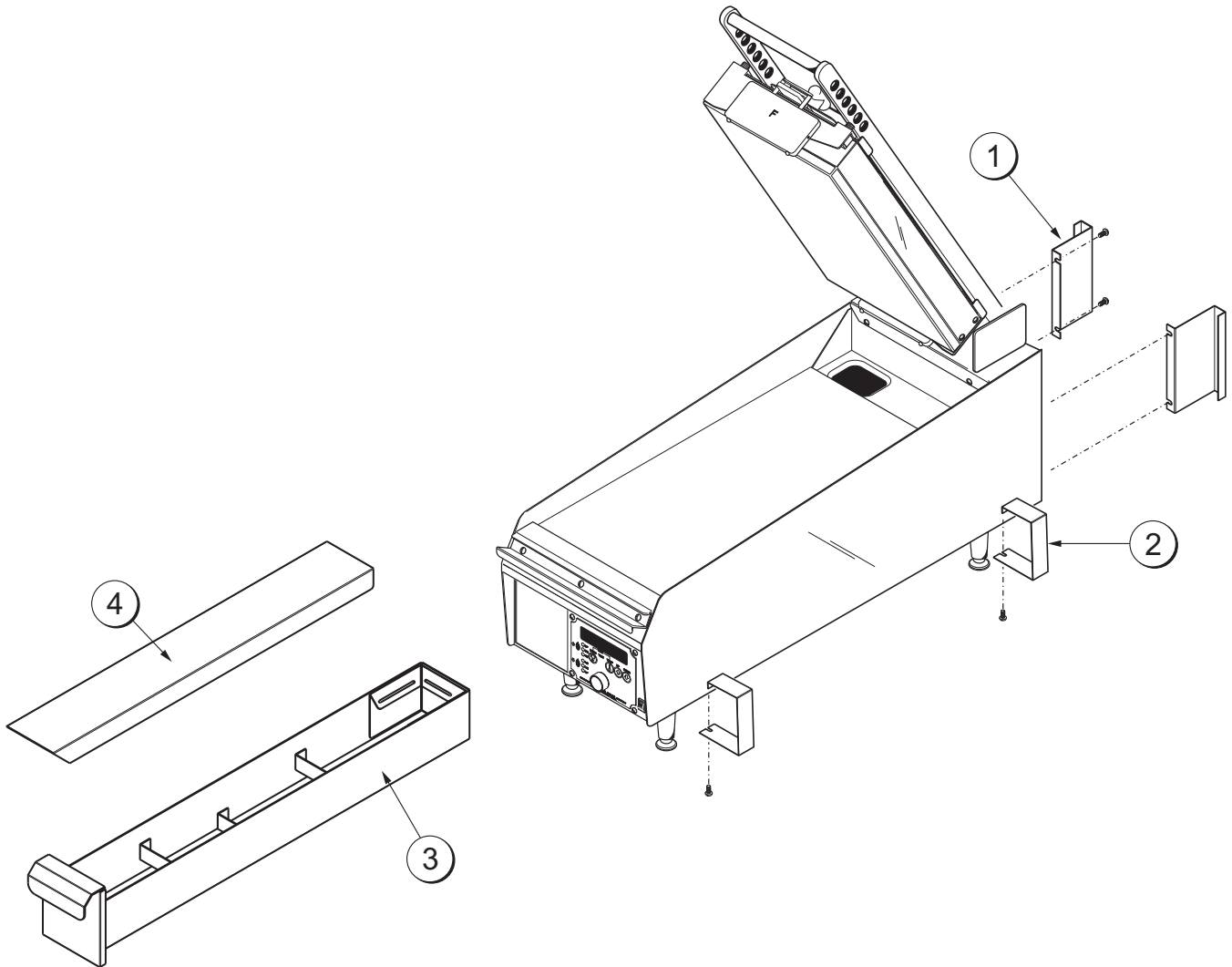

Figure 12

ITEM	DESCRIPTION	PART NO.
1	STANDOFF-REAR	079288
2	STANDOFF-FRONT	079289
3	TRAY A. - GREASE	X79940-SER

ITEM	DESCRIPTION	PART NO.
4	COVER-TOP	079969
*	CLEANER-SIZZLE	079896

*NOT SHOWN

QS24

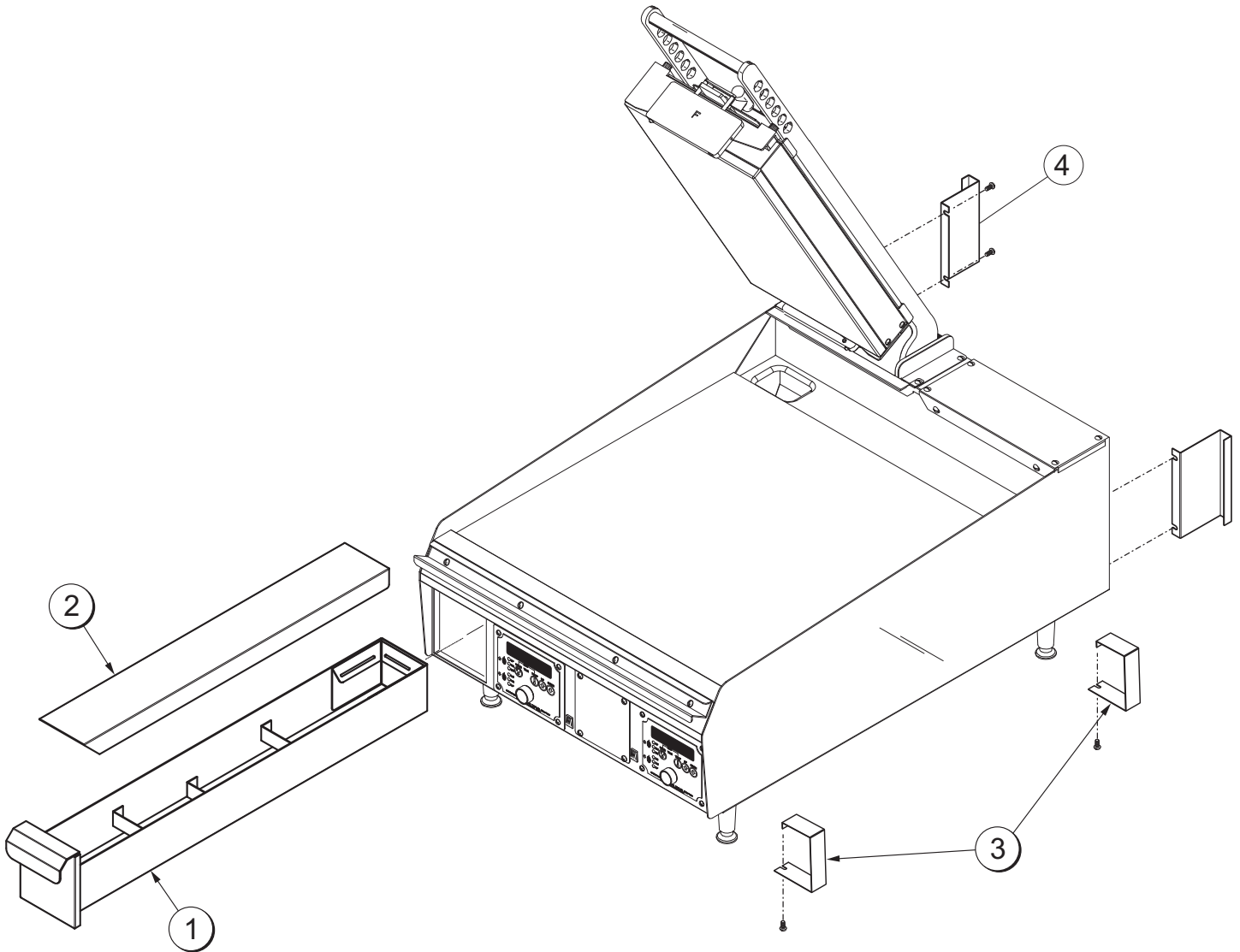

Figure 13

ITEM	DESCRIPTION	PART NO.
1	TRAY A.-GREASE	X79940-SER
2	COVER-TOP	079969
3	STANDOFF-FRONT	079289

ITEM	DESCRIPTION	PART NO.
4	STANDOFF-REAR	079288
*	CLEANER-SIZZLE	079896

*NOT SHOWN

QS12 Accessories

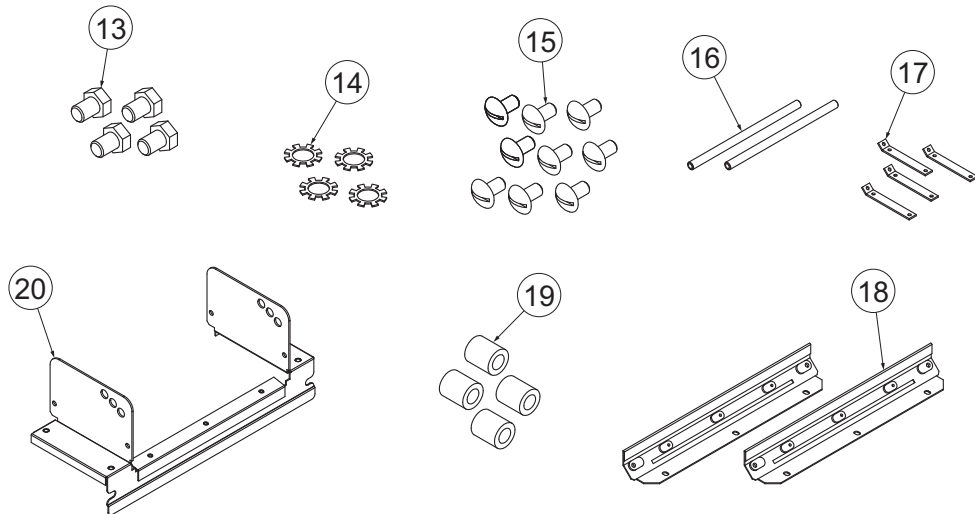
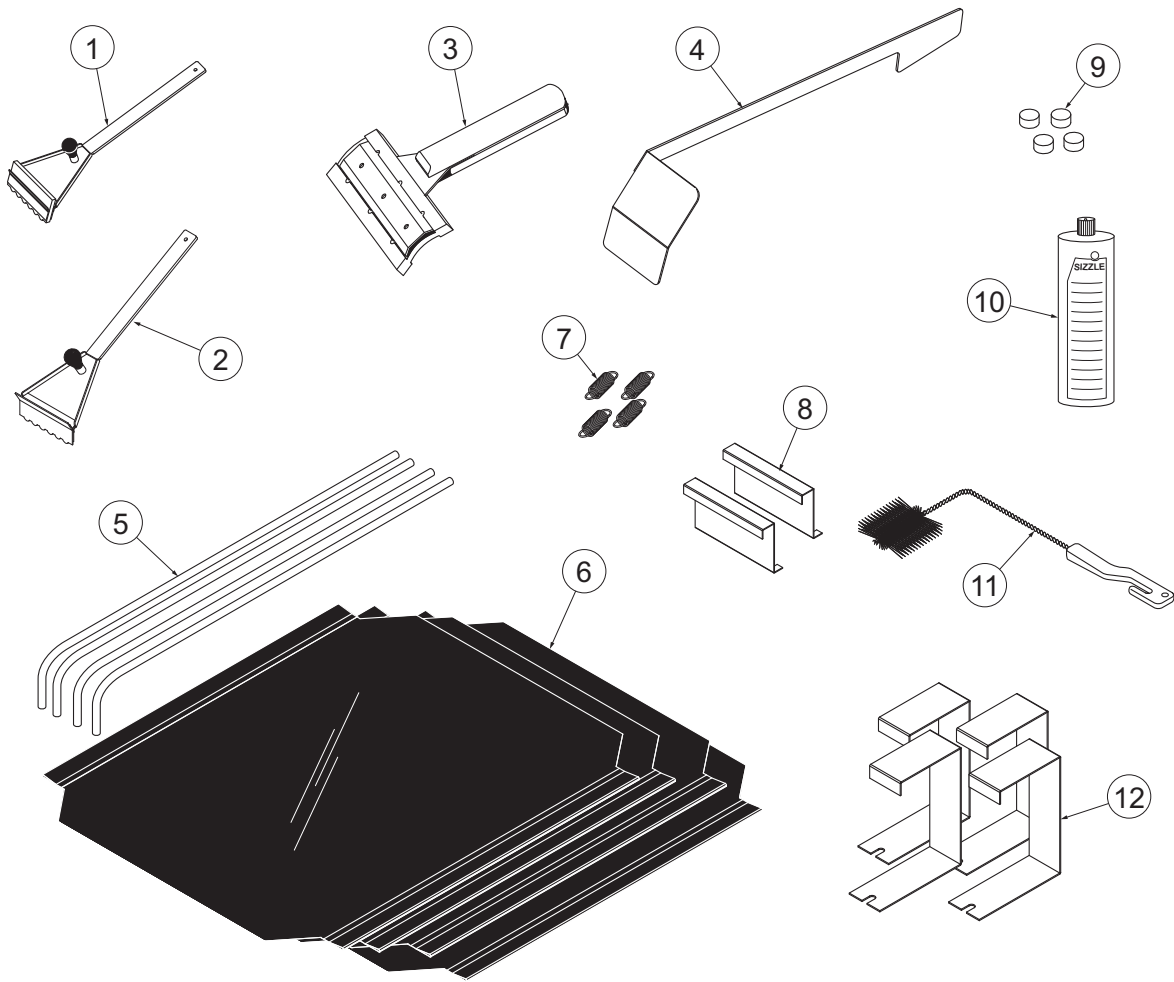

Figure 14

QS12 Accessories - Parts Identification

ITEM	DESCRIPTION	PART NO.
1	SCRAPER A.-GROOVE	X79246
2	SCRAPER A.-GROOVE	X79668
3	SCRAPER-TEFLON WIPER	075887
4	SCRAPER-TROUGH	079726
5	BAR-RELEASE SHEET	079930
6	SHEET-SEAMED RELEASE	078804
7	SPRING-.438 OD X .046 X 1.75	079704
8	STANDOFF-REAR	079288
9	BLOCK-GAGE PLATEN KIT	079912
10	CLEANER-SIZZLE 1 QT 545A	079895
11	BRUSH-.625 X 1.500	074166
12	STANDOFF-FRONT	079289
*	CARD-CHECKOUT-GRILL GM	049990
*	GUIDE-CHECK OUT-QS	051934

ITEM	DESCRIPTION	PART NO.
ITEMS 13-20 ARE INCLUDED IN X79689 KIT		
13	SCREW-3/8-16X1/2 HEX HEAD	001081
14	WASHER-3/8 EXTERNAL	001087
15	SCREW-10-32X3/8 SLTD	024298
16	BAR-STOP	079673
17	BAR-REAR-COVER SUPPORT	079855
18	GUARD A.-FRONT	X79426-SP
19	SLEEVE-STOP BAR	079688
20	COVER A.-REAR	X79674

*NOT SHOWN

QS24 Accessories

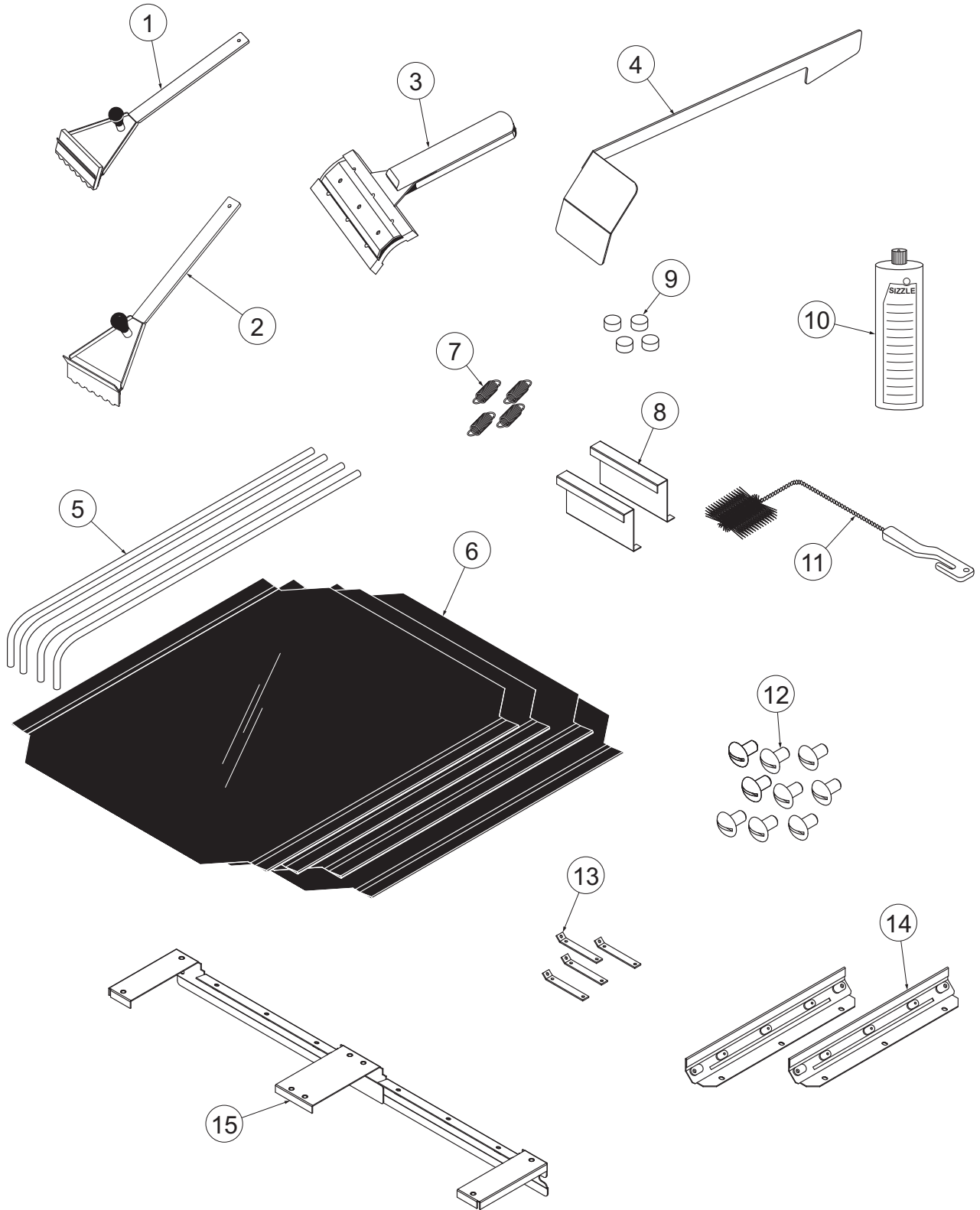

Figure 15

QS24 Accessories - Parts Identification

ITEM	DESCRIPTION	PART NO.
1	SCRAPER A.-GROOVE	X79246
2	SCRAPER A.-GROOVE	X79668
3	SCRAPER-TEFLON WIPER	75887
4	SCRAPER-TROUGH	079726
5	BAR-RELEASE SHEET	079930
6	SHEET-SEAMED RELEASE	078804
7	SPRING-.438 OD X .046 X 1.75	079704
8	STANDOFF-REAR	079288
9	BLOCK-GAGE PLATEN KIT	079912

ITEM	DESCRIPTION	PART NO.
10	CLEANER-SIZZLE 1 QT 545A	079895
11	BRUSH-.625 X 1.500	074166
12	SCREW-10-32X3/8 SLTD	024298
13	BAR-REAR-COVER SUPPORT	079855
14	GUARD A.-FRONT	X79426-SP
15	COVER A.-REAR	X74332
*	CARD-CHECKOUT-GRILL GM	049990
*	GUIDE-CHECK OUT-QS	051934
*	INSTRUCTION-GRILL OPER	053656-INS

*NOT SHOWN

Section 5

Important: To the Operator

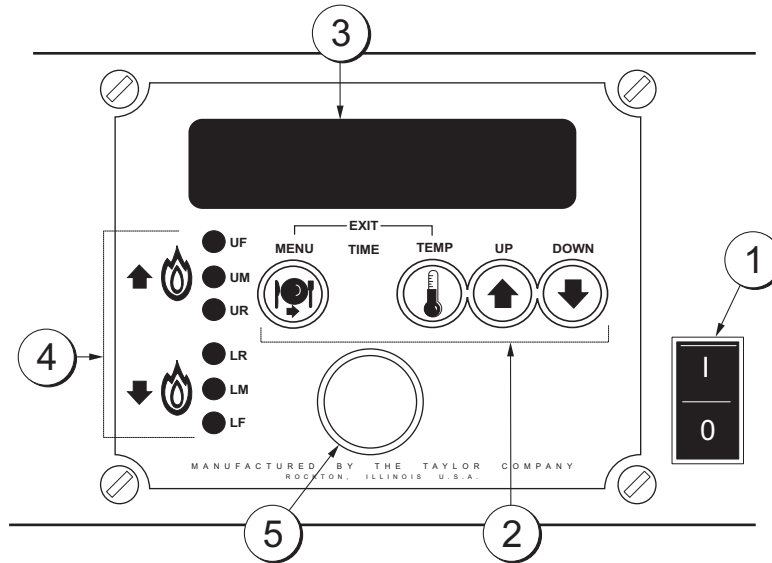

ITEM	DESCRIPTION
1	Power Switch
2	Keypads
3	LED Display
4	Indicator Lights
5	Timer Button

Power Switch (Rocker)

When placed in the “ON” position, the power switch allows control panel operation for the applicable side of the grill. The power switches are located on the front panel.

Indicator Light

The lights on the front panel indicate when the heaters are operating.

Heating Zones

Each side (zone) of the grill is equipped with three independent heating elements. The independent elements assure even temperatures and quick temperature recovery.

Timer Button

Used to start and stop the cook timer.

Release Material (units with upper cook surfaces only)

Step 1

Lay the release material sheet on the lower plate and carefully lower the upper cook surface.

Step 2

Starting with the spring side, slide the straight end of the release material rod through the front spring, continue through the hemmed end of the release sheet, and through the rear spring.

Step 3

Insert the second rod through the opposite hemmed side of the release material sheet. Grasp both ends of the rod, pull the release material up and around the non-spring side of the upper cook surface and attach the rod ends to the retaining clips. Turn the rods so that the hooked end is facing downward.

Step 4

Raise the upper cook surface and assure that the release material sheet fits evenly and snugly on the upper cook surface. Rotate the release material sheet on an every other day basis.

Temperature Controls

The Model QS12 is equipped with one temperature control and the Model QS24 is equipped with two individual temperature controls. They control both the upper and the lower temperatures. The lower cook surface temperatures can be set manually from 150° - 400°F (65° - 204°C). The upper cook surface temperatures can be set manually from 150° - 425°F (65° - 219°C). The left and right sides (zones) of the Model QS24 grill operate independently.

Control Board

This unit is equipped with a microprocessor control, programmable by the operator.

Keypad and Display

Located on the front panel, beneath each cook zone, is an alpha-numeric LED display and a group of keys used for operating, programming, and servicing the grill and its microprocessor control.

The keys are illustrated with icons, descriptive of their functions, and referred to in these instructions as follows:



= MENU



= TEMP



= UP ARROW



= DOWN ARROW

The display is a visual message center for the user, operator (maintenance personnel or manager), and the service technician.

Operating Screen and Controls

The VERSION SCREEN is viewed when a grill is powered for normal operation. It indicates the version of software the microprocessor is using.

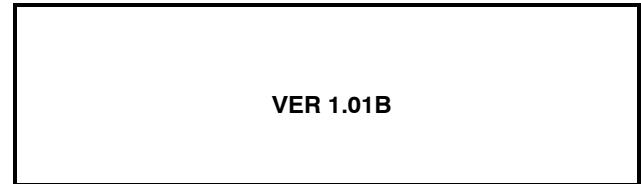

Note: If the grill is not equipped with the upper cook surface option, the words "NO PLTN" will appear on the display for two seconds before the version screen appears.

The MEMORY INITIALIZATION SCREEN appears if the grill has never been used or in the rare event that set-up parameter memory has been lost.



When this screen appears on the display, the parameters previously programmed by the operator will revert back to the factory default values. Pressing the MENU key will advance the display to the VERSION screen.

Factory defaults:

Upper	400°F	TM1	30
Lower	325°F	TM2	0

If set-up parameter memory is lost, programmed names will revert back to the "ITEM" messages.

After the VERSION SCREEN is displayed and a key is pressed, the grill will enter the COOK mode of operation.

Cook Temperatures

Step 1

To set cook temperatures, press the up or down arrow to select the item to be changed. Press and hold the temperature key for five seconds. After releasing the key, the message "SU1" and the current set temperature will be displayed. (See example below.)

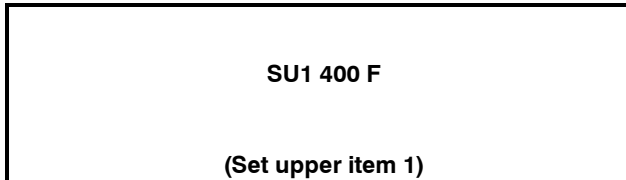

Step 2

Use the arrow keys to adjust the desired cook temperature setting for the upper cook surface. Temperatures may be set for 150°F to 425°F (66° to 218°C).

Step 3

Press the MENU key and the message "SL1" and the current temperature will appear on the display. (See example below.)

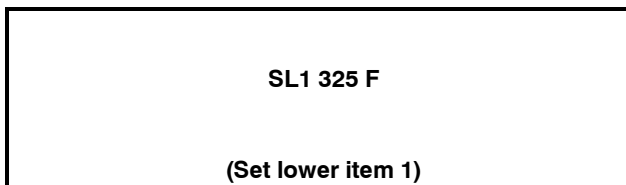

Step 4

Use the arrow keys to adjust the desired cook temperatures for the lower cook surface. The range for the lower cook surface temperatures is 150°F to 400°F (66° to 204°C).

Press the MENU key again to return to the selected item display.

Cook Timers

Each item selection has two programmable cook timers. The first timer is the cook cycle timer. This timer measures the amount of time the product should be cooked.

The second timer is an alert timer. This timer can be set to alert the operator to add seasonings, to turn the product, or to start warming buns for the cooked product.

For example, item one has been programmed to cook for 30 seconds. The operator wishes to add salt in the

middle of the cook cycle. Timer two should then be programmed for 15 seconds. Once the cook cycle begins, a tone will sound 15 seconds after the first timer starts, alerting the operator to season the product. Press the timer key to stop the tone. The first timer will continue to measure the full 30 second cook cycle.

A tone will sound 5 seconds before the time elapses, and will continue to sound until the timer key has been pressed. (This timer can be adjusted from 0 - 10 seconds.)

Note: The factory default settings are 30 seconds for the first (cook cycle) timer, and 0 seconds for the second (alert) timer. The timers can be set from 0 to 3,600 seconds. The second timer cannot be programmed for a longer time setting than the first timer.

To adjust the timers, press the up or down arrow to select the item to be changed. Press and hold the time key for five seconds. Release the key and the message "TM1" will appear next to the current time setting. (See the example below.)

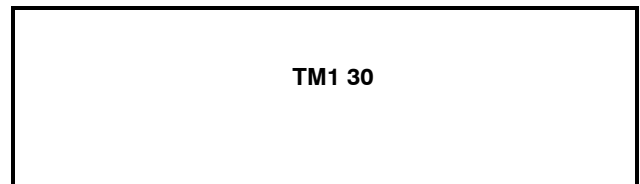

Step 1

Press the UP or DOWN arrows to adjust the time setting for the total cook cycle.

Step 2

Once the desired cook time has been set, press the MENU key and the message "TM2" will appear next to the current time setting. (See the example below.)

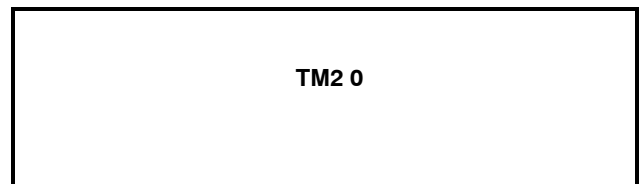

Step 3

Press the UP or DOWN arrows to adjust the time setting for the alert timer (timer 2).

Step 4

Once the desired alert timer has been set, press the MENU key to return to the selected item display. Repeat this step for each item.

Fault Screen

If the grill experiences a system failure, a fault message will appear on the display, and a tone will sound.



An example of the FAULT SCREEN is illustrated in the previous figure. The screen appears when the controller has detected a fault in the system. The code letters "FLT" is an abbreviation for "fault". The next set of code letters indicate the type of fault and the zone affected. Following is a list of possible codes that may appear on the screen:

HTUF High Temperature Upper Front zone exceeded

HTUM High Temperature Upper Mid zone exceeded

HTUR High Temperature Upper Rear zone exceeded

HTLF High Temperature Lower Front zone exceeded

HTLM High Temperature Lower Mid zone exceeded

HTLR High Temperature Lower Rear zone exceeded

TCUF Upper Front thermocouple fault

TCUM Upper Mid thermocouple fault

TCUR Upper Rear thermocouple fault

TCLF Lower Front thermocouple fault

TCLM Lower Mid thermocouple fault

TCLR Lower Rear thermocouple fault

The user must press the MENU and TEMP keys to acknowledge the fault. The fault description and item name will appear alternately on the display. The zone that has the fault will shut down while the rest of the grill will be operational. (Refer to the Fault Screen information in the Service Manual, Controls and Systems Section.)

Maintenance Menu

The Maintenance Menu provides five screens to allow managers and service technicians to monitor grill performance.

To enter the Maintenance Menu while any item is displayed, press and hold the MENU key for approximately 5 seconds and release. The following screen will appear on the display.

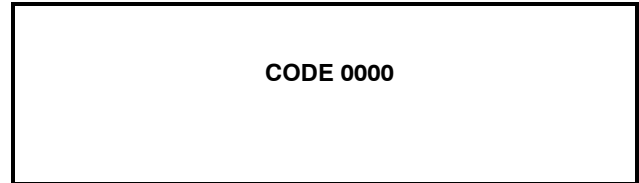

Press TIME until the first digit is "5".

Example: CODE 5000.

Press TEMP until the next digit is "3".

Example: CODE 5300.

Press the UP Arrow until the next digit is "7".

Example: CODE 5370.

Press the DOWN Arrow until the last digit is "6".

Example: CODE 5376.

Press the MENU key to accept the access code and the following screen will appear:



Note: If an incorrect code is entered, the display will return to the cook screens.

Step 1

Press the MENU key to enter the calibrate mode and the following message will appear on the screen.



There are three lower heating elements in each cook zone and three heating elements in the upper cook surface (if applicable). The calibrating screens allow calibration of each independent heating element. Calibrating verifies proper temperatures of heating elements.

Note: A calibrated pyrometer must be used for calibration.

Note: Calibration is allowed only when the item1 temperatures are within 50° F (28° C) of the set point.

Step 2

Place the pyrometer disc on the upper front heating element of the grill. Using the arrow keys, enter the temperature reflected on the pyrometer for the upper, front heating element.

Note: The indicating lights should be lit when calibration adjustments are made.

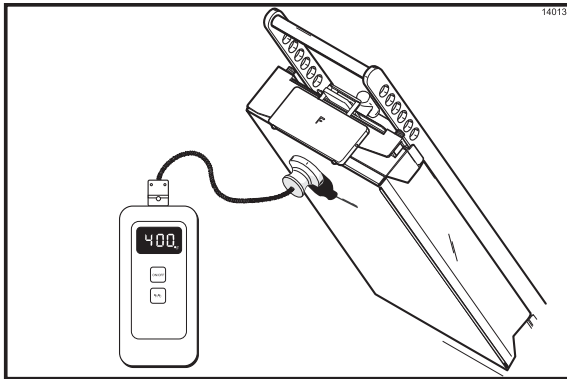

Figure 16

Step 3

Press the MENU key to display the calibration screen for the upper middle heating element. Place the pyrometer on the upper middle heating element. Using the arrow keys, enter the temperature reflected on the pyrometer for the middle of the upper heating element.

Step 4

Repeat this procedure for the remaining upper rear, and lower heating elements. When the last zone has been calibrated, press the MENU key to return to the CALIBRAT screen.

Step 5

Press the UP arrow to display the “SCALE” message.



Note: The CALIBRAT screen is the base maintenance screen. All other maintenance functions are accessible through the CALIBRAT screen.

Step 1

Press the MENU key to display the current temperature scale:

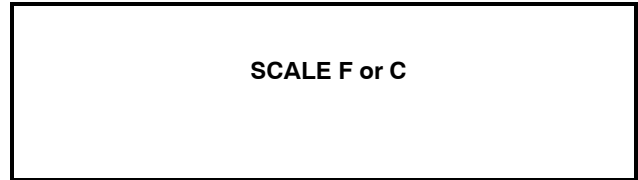

Step 2

If Fahrenheit is the desired temperature scale, press the MENU key while **SCALE F** is displayed. If Celsius is desired, press the UP arrow to display **SCALE C**.

Step 3

Press the MENU key to accept the scale and return to the SCALE message.

Step 4

If desired, the names of specific products can be programmed to appear on the display instead of ITEM numbers. While at the SCALE message display, press the UP arrow to display the **NAMES** message.

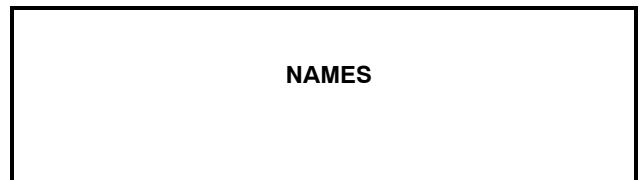

Step 5

While at the NAMES message display, press the MENU key and the message “NAME1” will appear on the display. This message indicates that the operator can program a specific product name to appear for the first item on the menu.

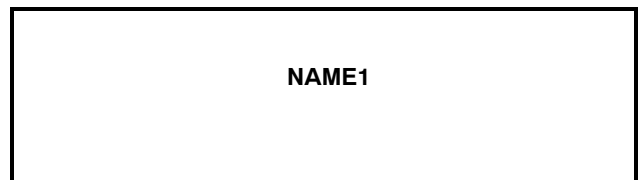

Step 6

Press the MENU key again, and the message “ITM1” will appear on the display. The letter “I” will be flashing above the cursor.

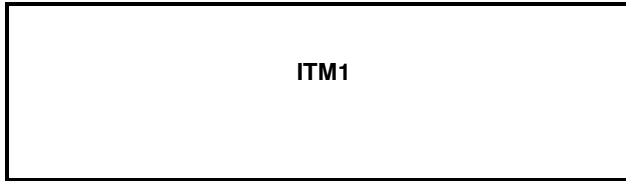
**Step 7**

Using the UP and DOWN arrow keys, enter the desired letter (A - Z) or number (0 - 9) (- _). Once the character letter is entered, press the MENU key to move the cursor to the next position. Up to four characters may be entered.

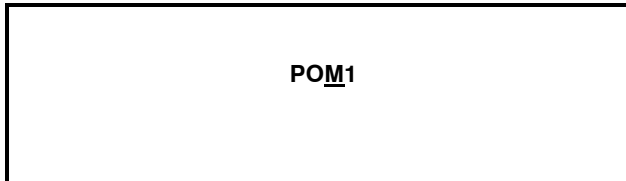
**Step 8**

After the last character has been entered, press the MENU key to return to the message “NAME1”.

Step 9

Use the UP arrow key to display the message “NAME2.”

Repeat Steps 6-9 until all desired item names have been entered.

Step 10

After entering the desired characters in the NAMES screens, the control will return to “NAME1”.

Press the DOWN arrow to display “NAMES”.

Step 11

Press the UP arrow to display “LANGUAGE”, and press the MENU key to display “ENGLISH”.

Press the MENU key to return to the “LANGUAGE” display.

Step 12

Press the UP arrow to display “MONITOR”.

Press the MENU key to display “UF XXX F” to monitor the upper front temperature.

Step 13

Continue to press the UP arrow to monitor the remaining five zones.

Step 14

Press the UP arrow to display “CANCEL”, and press the MENU key to display “MONITOR”.

Press the MENU and TEMP keys at the same time to return to the main cook screen.

Maintenance Menu Flowchart

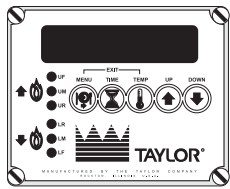

- PRESS and hold for approximately 5 seconds. **CODE 0000**
- PRESS to increment first digit to "5". **CODE 5000**
- PRESS to increment second digit to "3". **CODE 5300**
- PRESS to increment third digit to "7". **CODE 5370**
- PRESS to increment fourth digit to "6". **CODE 5376**

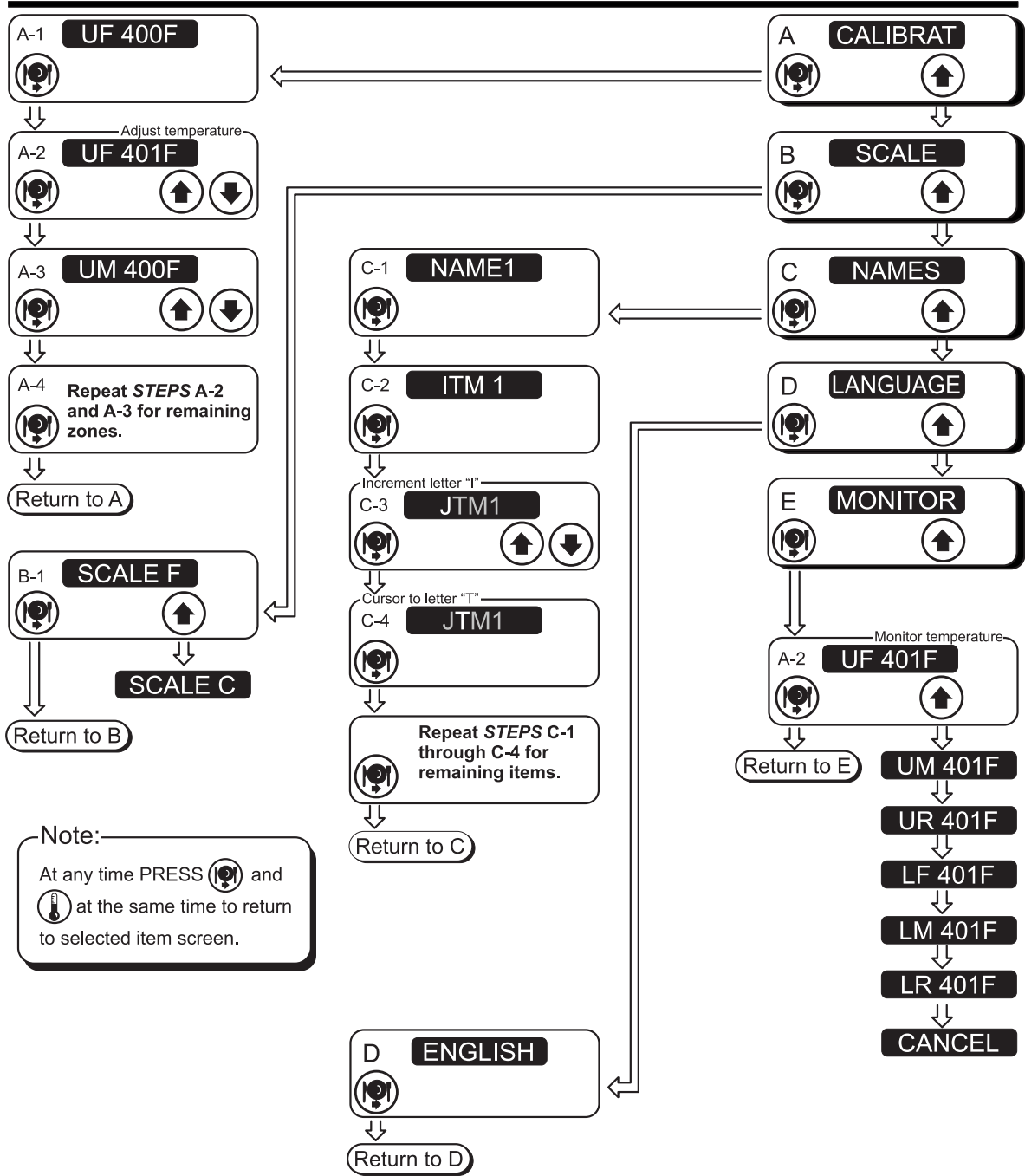

Note:
At any time PRESS and at the same time to return to selected item screen.

Section 6

Operating Procedures

The Model QS12 has one, 12" (305 mm) lower cook surface and the option of an 11" (279 mm) upper cook surface. The Model QS24 has two, 12" (305 mm) lower cook surfaces and the option of one 11" (279 mm) upper cook surface or two 11" (279 mm) upper cook surfaces. The QS24 is also available with a grooved lower cook surface for product sear. The two-sided cooking concept ensures quick, even cooking of both sides of products placed on the lower surface.

We begin our instructions with the opening procedures, assuming product set-up procedures (outlined in the "Important to the Operator" section of this manual) are complete.

Opening Procedures

Before operating the grill, a release material sheet must be installed on the upper cook surface.



CAUTION: Make sure the grill is cool before attempting to install or remove release material.

Perform the following steps for installing release material:

Step 1

Lay the release material sheet on the lower plate and carefully lower the upper cook surface.

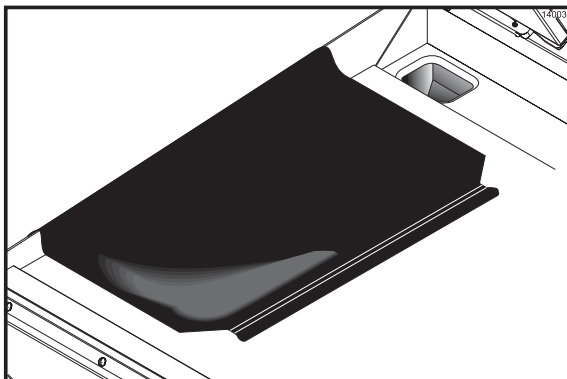

Figure 17

Step 2

Starting with the spring side, slide the straight end of the release material rod through the front spring, continue through the hemmed end of the release sheet, and through the rear spring.

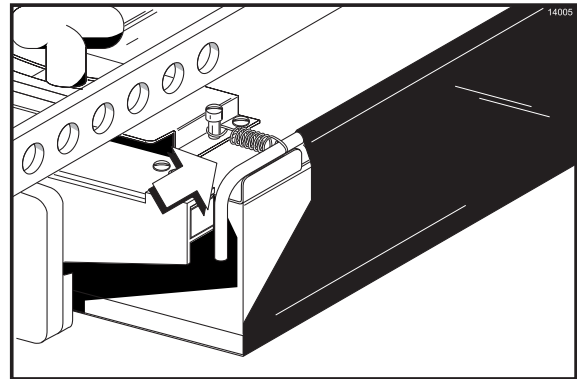

Figure 18

Step 3

Insert the second rod through the opposite hemmed side of the release material sheet. Grasp both ends of the rod, pull the release material up and around the non-spring side of the upper cook surface and attach the rod ends to the retaining clips. Turn the rods so that the hooked end is facing downward.

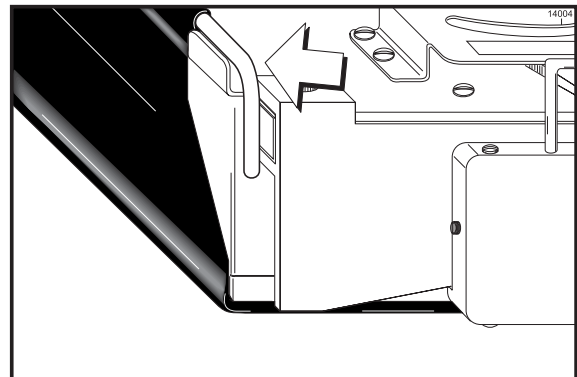

Figure 19

Step 4

Raise the upper cook surface and assure that the release material sheet fits evenly and snugly on the upper cook surface. Rotate the release material sheet on an every other day basis.

Note: It is not necessary to replace the release material sheet if small pinholes develop.

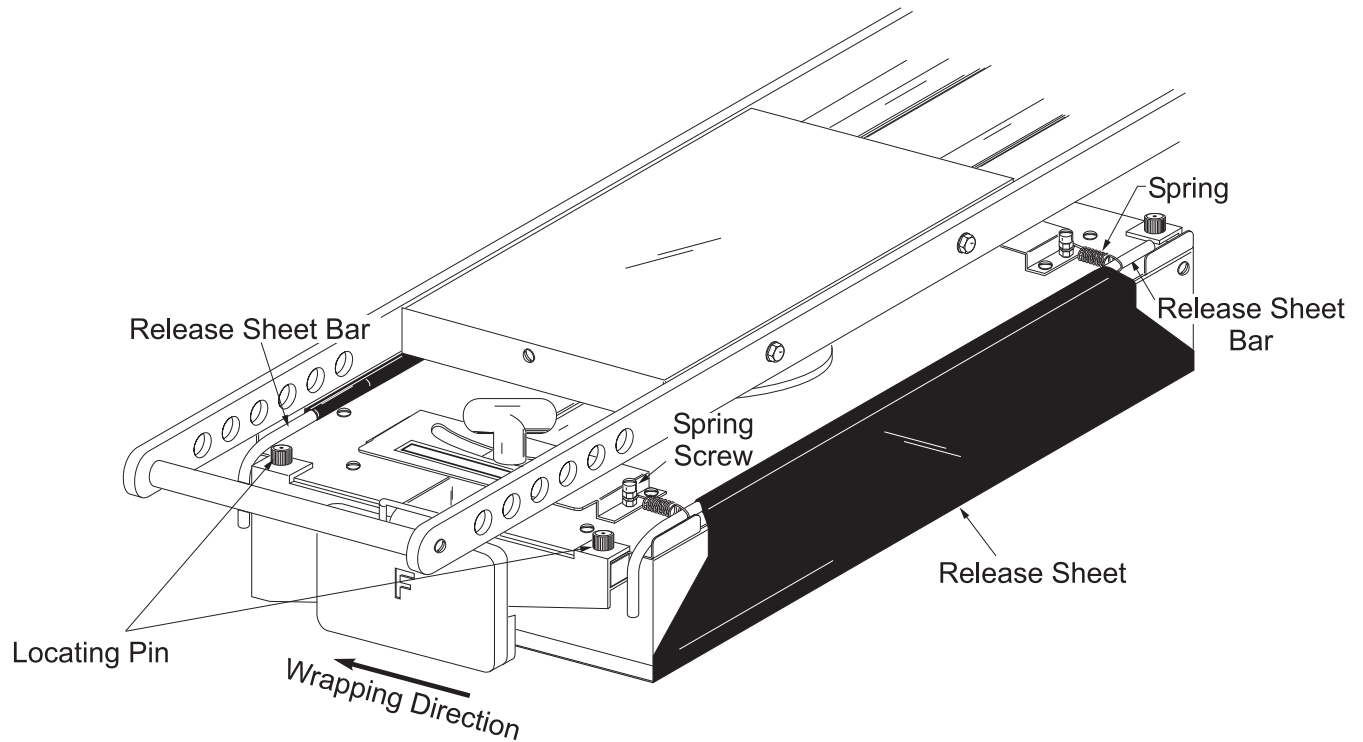

Figure 20

CAUTION: Release material sheets must be replaced if:

- Release material is torn.
- Release material substance is worn from the release material sheet.
- Product sticks to the release material.

Cooking Procedures

Step 1

Make sure the release material is installed.

Step 2

Place the power switches in the ON position. The screen will scroll through information messages and then advance to the first cook screen.

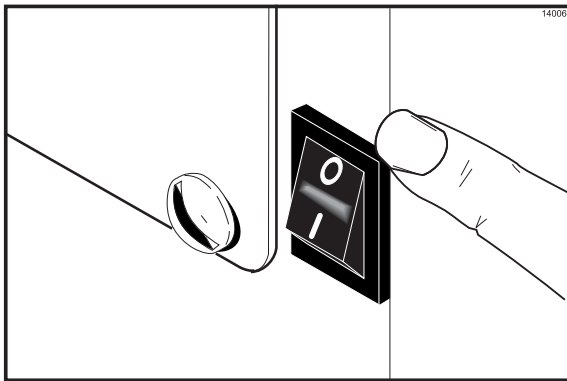

Figure 21

Note: If there is no upper cook surface, the words "NO CLAM" will appear on the screen prior to the software version number.

Step 3

Press the UP arrow until the desired item number appears on the display.

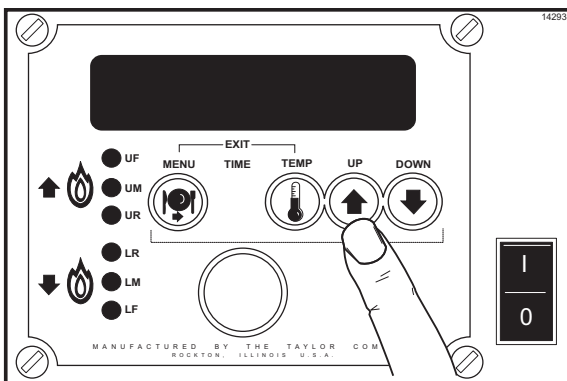

Figure 22

Step 4

Allow the grill to heat for approximately 15 minutes or until all indicating lights are no longer illuminated.

DO NOT begin cooking until the grill has reached set temperature. If the grill is not at cook temperature, the display will alternate between the item number and the words, "TOO COOL". If the grill is too hot to cook the selected product, the display will alternate between the item number and the words "TOO HOT". When the words "TOO COOL" or "TOO HOT" stop appearing on the display, and all indicator lights have cycled off, the grill is ready to cook product.

Step 5

To adjust the gap between the upper cook surface and lower cook surface, loosen the "T" handle and slide the gap adjusting bar to the right for a smaller gap or to the left for a larger gap.

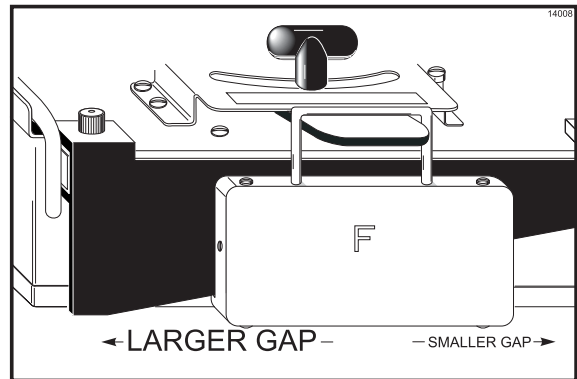

Figure 23

Step 6

While the upper cook surface is in the raised position, place the product on the lower cook surface. Lower the upper cook surface, and press the TIME key. A tone will sound for two seconds, alerting the operator that the cook cycle has been initiated.

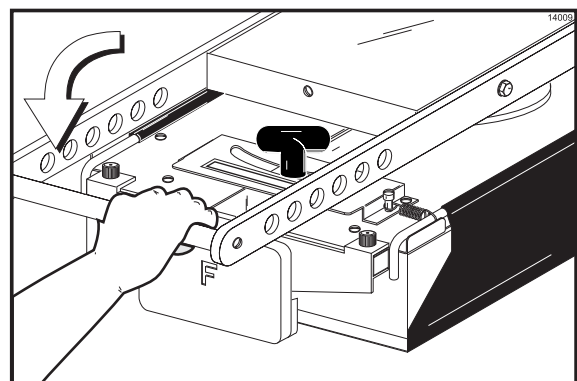

Figure 24



CAUTION: The grill is hot. To prevent personal injury, always use the handle to lower the upper cook surface.

Step 7

If the timer is programmed, press the large red TIMER button. A tone will sound for two seconds, alerting the operator that the COOK cycle has been initiated. The timer will count down in seconds. When five seconds are left in the cook time, a tone will sound to alert the operator that product is ready for serving. Raise the upper cook surface. (If a second timer is entered, subtract that amount from the total time and a tone will sound. Press the large red TIMER button to stop the tone and the control will continue to count down.)

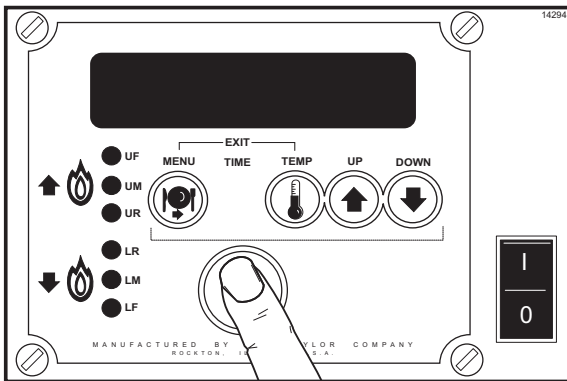

Figure 25

To cancel the tone, press the large red TIMER button.

Step 8

Carefully remove product with a safe cooking utensil in the same order the product placed on the grill.

Cleaning Between Product Runs

After each run of product, the grill must be cleaned to ensure proper cooking.

Step 1

Using a grill scraper, scrape residue from the lower cook surface (scrape from front to back only).

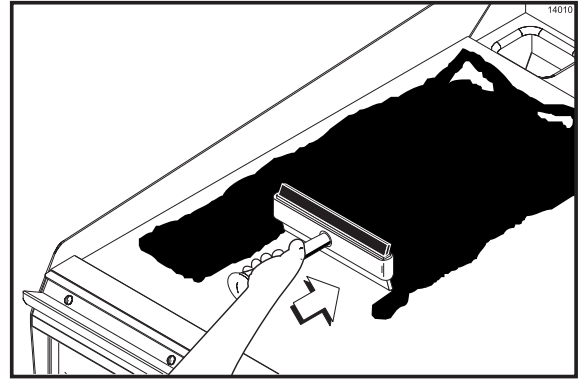

Figure 26

Step 2

Use a rubber wiper squeegee to clean release material on the upper cook surface. Hold the handle at a slight upward angle with wiper end facing downward. Wipe the material using a downward motion. **DO NOT** use extreme pressure or force. Improper procedures will tear or crease the release material.

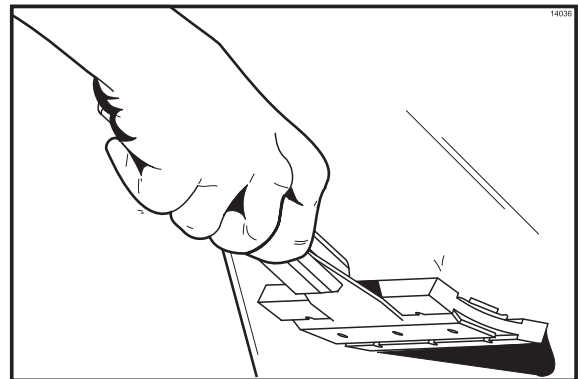

Figure 27

Note: **DO NOT** use a scraper, sharp utensils, or abrasives for cleaning the upper cook surface.

Step 3

Using the rubber wiper squeegee, push the grease to the rear of the lower surface into the grease trough. **DO NOT** use the grill scraper for this step.

Step 4

When necessary, use a grill cloth to clean the back splash shield and the bullnose areas.

Step 5

Repeat Steps 1 through 4 for other side of the grill (QS24 only).

Note: Whenever the grill is idle and product is not being cooked, keep the upper cook surface in the raised position.

When necessary, use the trough scraper to clean the rear grease trough. If a buildup of carbon is starting in the grease chute, use the hook end of the trough scraper to push the carbon down into the grease tray. Periodically, check the grease drawer for excess grease and empty it as needed.

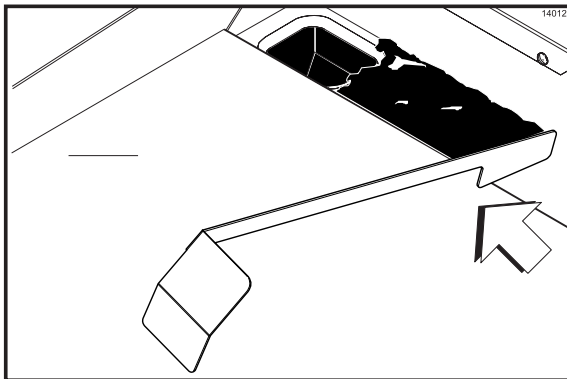

Figure 28

Cleaning the Grease Tray Partition

Occasionally, the grease tray partition must be cleaned.

Step 1

Place the power switch in the OFF position.

Step 2

Carefully unplug the unit from the wall receptacle.

Step 3

Remove the grease tray.

Step 4

Remove the four screws that secure the grease tray partition.

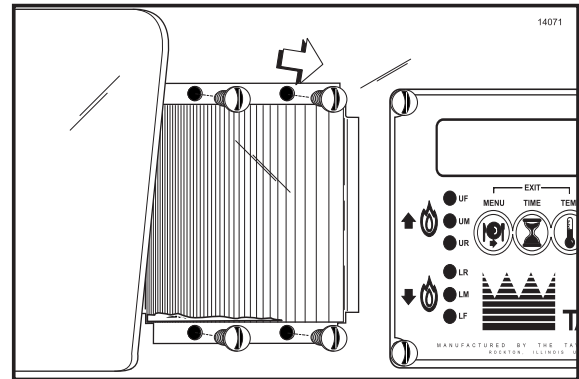

Figure 29

Step 5

Carefully remove the grease tray partition. Take it to the sink for cleaning.

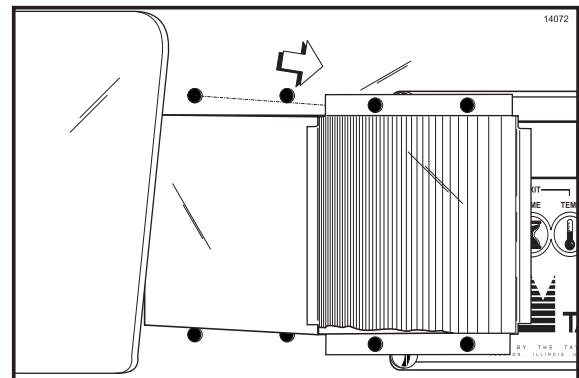

Figure 30

Note: For installation of the grease tray partition, carefully reverse the above steps.

It is highly recommended that the gap slides and the gap slide retainers be removed at least weekly for cleaning these parts and the cook surface shroud behind these parts.

These parts are easily removed by removing the locating pins and holding both parts, because they are not attached together, and pulling them from the cook surface.

Take the gap slides to the sink for cleaning. (Be sure to re-install the gap slides as they were removed, i.e., "F" front.) See Weekly Cleaning Procedures on page 28.

Closing Procedures

Step 1

Raise the upper cook surface to the “raised” position.

Step 2

Turn the power switches to the OFF position.

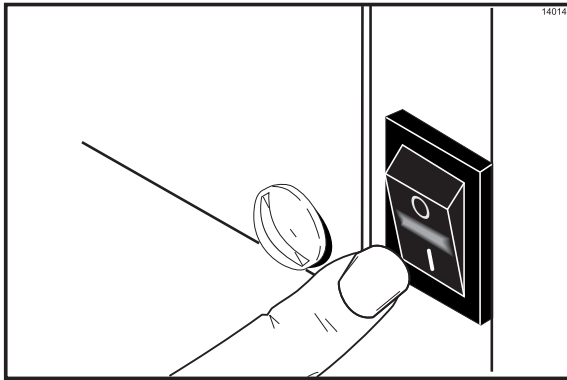

Figure 31

Step 3

Wipe the release material sheet thoroughly while still attached to the upper cook surface, using the rubber wiper squeegee.



CAUTION: The upper cook surface and release material sheets are very hot. To prevent burn injuries, wear protective gloves and use extreme care when performing this procedure.

Step 4

Remove the release material sheet from the upper cook surface by pulling the release rods from the release material sheet. Temporarily place the release material sheet on a clean, flat surface for further cleaning. **DO NOT** fold or crease the material or lay it on sharp objects.

Step 5

Take the release material rods to the sink for cleaning.

Step 6

Clean the upper cook surface(s) with the special rubber squeegee.

Note: **DO NOT** use metal scrapers, abrasive pads, screens or wire brushes to clean the upper cook surface.

Step 7

Dampen the gap slide brush with an approved, full strength cleaner/degreaser (i.e., Sizzle® Grill Bun and Toast Cleaner, a Kay Chemical® product).

Step 8

Clean the shroud by brushing between the platen shroud and the gap slides.

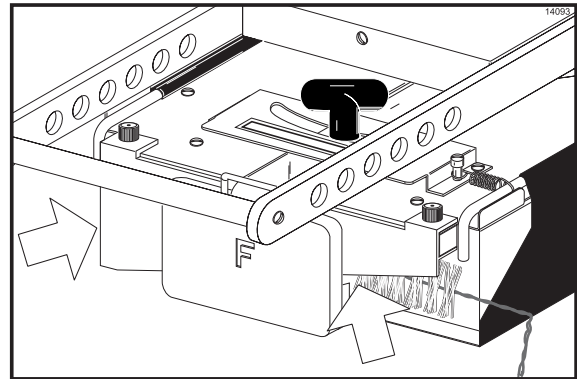

Figure 32

Step 9

Repeat Steps 7 and 8 with warm water.



CAUTION: Protect eyes, lungs, and all parts of the body from potential harm when using any chemical cleaner.

Step 10

Starting from the top of the upper cook surface, spray full strength cleaner/degreaser (i.e., Sizzle® Grill Bun and Toaster Cleaner, a Kay Chemical® product.) from 6” (152 mm) away. **(Use a cleaner that will not damage aluminum.)** Spray one ounce of cleaner over each upper cook surface and two ounces on the lower cook surface. Let the cleaner soak for 3 – 5 minutes.

Note: One ounce of cleaner equals approximately thirty squirts.

Step 11

Starting from the top of the upper cook surface and the rear of the lower cook surface, rinse both surfaces with a mist of water from a spray bottle.



CAUTION: Use care not to spray water or cleaner/degreaser on any part of the grill, other than the cook surfaces. Improper procedures will cause permanent electrical and mechanical damage to internal parts.



IMPORTANT: Do not use a jet of water to clean or rinse the grill.

Step 12

Use the rubber wiper squeegee to remove excess liquid from the upper and lower surfaces.

IMPORTANT! Do not scrape the upper surface with metal utensils. It is aluminum and will scratch very easily.

Step 13

Repeat Steps 10 and 11 if necessary, but apply cleaner only to soiled areas.

Step 14

Remove any small carbon spots with the rubber squeegee.

Step 15

Using a damp cloth, wipe down all exterior stainless steel of the upper cook surface (especially behind the rear of the upper cook surface, next to arm assembly).

Note: Grills should be removed from cooking alcoves in order to clean the rear section of the upper cook surface.

Step 16

Clean lower grill by pouring warm water carefully on the surface while brushing with sturdy brush.



CAUTION: Wear rubber gloves to avoid hot steam.

Step 17

Continue to add water and brush the surface until the grill is cool enough to squeegee dry.

Step 18

Wipe the cook surface(s) twice with a clean, damp towel.

Step 19

Wipe all areas of the grill with a clean, damp towel.

Step 20

Wipe all exterior stainless steel panels around the entire grill.



CAUTION:

- **Never** use cold water or ice to cool the upper cook surface or lower grill plate.
- **Never** use grill screens on the upper cook surface or lower grill plate.
- **Never** use any other abrasives or cleaners other than approved food service cleaners and degreasers.
- **Never** spray excessive amounts of water on the grill.
- **Never** pour or spray liquid of any type on the top of the upper cook surface.

Step 21

Place release material sheet(s) on the warm lower grill plate and thoroughly wipe down both sides with a clean, damp grill cloth.



CAUTION:

- **Never** attempt to clean release material sheets on a cold surface.
- **Never** use a hot hose for cleaning release material, or soak release material sheets in liquid.
- **Never** fold, crease or touch release material sheets with sharp objects.
- **Never** allow the grill scraper or abrasive cleaning materials to come in contact with release material sheets.

Step 22

Apply a light coat of shortening to the entire **lower** grill plate.

Weekly Cleaning Procedures

Step 1

Loosen, but do not remove the four locating pins that attach both sets of Gap Slide Retainers. One set is located at the front and one set is located at the rear of the upper platen.

Step 2

Lift the upper platen to the **raised** position. Remove the four locating pins on both ends of the platen.

Step 3

Remove both sets of the Gap Slide Retainers and Gap Slides. Take them to the sink for washing, rinsing and sanitizing. Wipe dry with a clean, sanitized towel.

Step 4

Re-install the Gap Slide Retainers and the Gap Slides in their original locations.

Note: The front Gap Slide set will be marked with an (F) to designate the front location. The rear set will not be marked.

Section 7

Troubleshooting Guide

PROBLEM	PROBABLE CAUSE	REMEDY
1. Grill will not heat.	<ul style="list-style-type: none"> a. Power cord is not connected. b. Circuit breaker is tripped. c. Power switch is in the OFF position. d. Power switch is faulty. e. Faulty relay or relay board. 	<ul style="list-style-type: none"> a. Check power connection. b. Reset the circuit breaker. c. Place the power switch in the ON position. d. Contact a service technician. e. Contact a service technician
2. One heat zone will not heat. (Indicator light is not on , display flashing "TOO COOL".)	<ul style="list-style-type: none"> a. Control is not set correctly. b. Faulty relay or relay board c. Unit displays a fault. d. Faulty thermocouple. 	<ul style="list-style-type: none"> a. Check temperature setting. b. Contact a service technician. c. Clear the fault. If action is ineffective, contact a service technician. d. Contact a service technician.
3. One heat zone will not heat. (Indicator light is on , display flashing "TOO COOL".)	<ul style="list-style-type: none"> a. Heater is faulty. b. Thermocouple is faulty. c. Thermo overload is faulty. d. Relay or relay board is faulty. e. Unit displays a fault. 	<ul style="list-style-type: none"> a. Contact a service technician. b. Contact a service technician. c. Contact a service technician. d. Contact a service technician. e. Clear the fault. If action is ineffective, contact a service technician.
4. One heat zone is overheating. (Display is flashing "TOO HOT".)	<ul style="list-style-type: none"> a. Thermocouple is faulty. b. Relay or relay board is faulty. c. Unit displays a fault. 	<ul style="list-style-type: none"> a. Contact a service technician. b. Contact a service technician c. Clear the fault. If action is ineffective, contact a service technician.
5. Upper cook surface will not stay in the raised position.	<ul style="list-style-type: none"> a. Defective gas filled cylinder(s). 	<ul style="list-style-type: none"> a. Contact a service technician.

PROBLEM	PROBABLE CAUSE	REMEDY
6. Product is under-cooked, overcooked, or cooking unevenly.	<ul style="list-style-type: none"> a. Release material sheet is worn. b. Incorrect cooking time. c. Incorrect temperature setting. d. Incorrect gap setting. e. Heat zone not heating. f. Upper cook surface has carbon build-up. g. Incorrect temperature calibration. h. Cook surfaces are not parallel. i. Incorrect item selected. 	<ul style="list-style-type: none"> a. Replace the release material sheet. b. Adjust cook time accordingly. c. Adjust temperature setting. d. Adjust gap. e. Contact service technician. f. Closing procedures must be followed to remove carbon build-up. g. Calibrate the grill accordingly. h. Call a service technician to level the grill or refer to leveling procedure in front of manual. i. Select proper item.
7. Control is displaying fault.	<ul style="list-style-type: none"> a. Refer to "fault screens", page 17. 	<ul style="list-style-type: none"> a. Clear the fault. If action is ineffective, contact service technician.
8. Grease drips from under the grease drawer.	<ul style="list-style-type: none"> a. Grease tray is full. 	<ul style="list-style-type: none"> a. Empty the grease tray.
9. The grease drawer will not close.	<ul style="list-style-type: none"> a. Product has built up in back of grease partition. 	<ul style="list-style-type: none"> a. Refer to "Cleaning the Grease Tray Partition" instructions.

Section 8

Warranty Explanation

Parts

Class 103 Parts

The warranty for new equipment is one year, with a replacement parts warranty of three months.

Class 000 Parts

Wear items - no warranty.

Class 212 Parts

The warranty for new equipment parts is two years, with a replacement parts warranty of 12 months. This includes the microprocessor control, relays, and the upper cook surface (aluminum casting and shroud).

Labor

The Taylor warranty is valid only if the required service work is performed by an authorized Taylor technician.

For more details, see the warranty/checkout card.

Contact your local Taylor Distributor regarding Extended Service Contract options.

Section 9

Parts List

DESCRIPTION	PART NUMBER	QS12 QTY.	QS24 QTY.	WARR. CLASS	REMARKS	PARTS UPDATE
BAR-RELEASE SHEET *QS24*	079930	2	2	103		137
BLOCK-GAGE PLATEN KIT	078095	4	4	103		
BLOCK-TERMINAL-5P SCREW W/JUMPERS	X79838		1	103	LEFT SIDE - J8050000/UP (50HZ & 60HZ)	
BLOCK-TERMINAL-5P SCREW W/JUMPERS	X79839-23R		1	103	RIGHT SIDE - J8050000/UP (60HZ)	
BLOCK-TERMINAL-5P SCREW	079045		1	103	LEFT SIDE - PRIOR TO J8050000	
BLOCK-TERMINAL-5P SCREW	079045-23R		1	103	RIGHT SIDE - PRIOR TO J8050000	
BLOCK-TERMINAL-6P SCREW	076943	1		103		
BOX A.-RELAY *QS12/QS24* (NEW)	X74036-SER	1	2	212	J9054573/UP - 50HZ & 60HZ FOR SERVICE - USE X74036-SER	143
CONNECTOR-MATE LOK 6 CIR-SKT	029248	2	4	103		
SOCKET-084 OD/14-20 AWG-STRIP	021625	9	18	103		
HARNES-WIRE (RELAY BOX)	074039	1	2	103		
PCB A.-CONTROL	X53512-SER	1	2	212		
PCB A.-CONTROL (BASE BOARD)	X53319-SER	1	2	212		
CHIP-SOFTWARE (VERSION 1.01)	X40788-SER	1	2	103		
RELAY-30A-277V-12VDC +BRACKET "E" RELAY	074041	6	12	103		
STRAP A.GROUNDING *QS24*	074040	6	12	103		
BOX A.-RELAY *QS12/QS24* (OLD)	X74123	1	2	000		
CONNECTOR-MATE LOK 6 CIR-SKT	X79678-SER	1	2	212	USE X74036-SER IN ALL APPLICATIONS	122, 143
SOCKET-084 OD/14-20 AWG-STRIP	029248	1	2	103		
HARNES-WIRE RELAY BOX *QS24*	021625	3	6	103		
PCB A.-CONTROL GRILL	078616	1	2	103	INTERFACE TO KEY PAD BOX	
CHIP-SOFTWARE *QS24* CONTROL	X48604-SER	1	2	212	USE X74036-SER	
PCB A.-INTERFACE GRILL	X40863	1	2	103		
RELAY-SPDT-200/240 VAC	X49540-SER	1	2	212	USE X74036-SER	
STRAP A.GROUNDING *QS24*	079690	3	6	103	J7100000-J9054572 (for 1800 WATT heater)	122
BOX A.-RELAY - (OLD)	X74123	1	2	000		
BOX A.-REMOTE KEY PAD *QS12 & QS24*	X78757	1	2	212	USE X74036-SER IN ALL APPLICATIONS	143
BEEPER-WITH WIRE HARNES *QS	X78579	1	2	212		
	078617	1	2	103		

+ Available Separately

DESCRIPTION	PART NUMBER	QS12 QTY.	QS24 QTY.	WARR. CLASS	REMARKS	PARTS UPDATE
BUMPER-.500 DIA X .090 THK	079499	1	2	000		
DECAL-KEY PAD *QS24*	X74320-SER	1	2	000		
BUMPER-.500 DIA X .090 THK	079499	1	2	000		
FILTER-CORCOM 2VR1	032567	1	2	103	PRIOR TO J9054573	143
GASKET-BOX A.	074060	1	2	000	J9054573/UP	143
HARNES- WIRE REMOTE *QS24*	078614	1	2	103		
PAD A.-KEY REMOTE *QS24*	X78573	1	2	103		
PCB A.- REMOTE GRILL	X50412-SER	1	2	212	J6041233/UP	
CHIP-SOFTWARE QSDSP CONTROL	X40908	1	2	103		
PCB A.- REMOTE GRILL					J6041232/PRIOR MUST UPDATE WITH X50412-SER PCB. A & X74320-SER DECAL	
SWITCH-MEMBRANE-5 POSITION-8"L	044520	1	2	103		
BRACKET-FRONT TRAY *QS12*	079272	1		103		
BRACKET-FRONT TRAY *QS24*	078527		1	103		
BRUSH-.625X1.500 QS12/24	074166	1	1	000	J9110000/UP	147
CLEANER-SIZZLE #545A	079896	1	1	000	CASE OF 6 QUARTS W/SPRAY BOTTLE	
CONNECTOR-MATE LOK 6 CIR-PIN	028594	2	4	103		
+PIN-MALE .084"DIA-MATE-N-LOK	021624	3	6	103		
CORD A.-POWER	X79291	1		103		
CORD A.-POWER	X79877	1		103	GROOVED PLATEN ONLY	
COVER A.-PLATEN *QS24*	X78798	1	1	103		
COVER A.-REAR *QS12*	X79444	1		103		
COVER A.-REAR *QS24*	X74332		1	103	REPLACES X79423	
COVER-LINKAGE *QS24*	079441		1	103		
CYLINDER-GAS DUEL SEAL QS24	074313	2	2	103	REPLACES 079215	
DECAL A.-KEYPAD QS SERIES	X74320-SER	1	1	000	GREEN (Replaces Old Red Decal - 078612)	
+BUMPER-.500 DIA X .090 THK	079499	1		000		
DECAL-MIN CLEARANCE *QS24*	079061	1	1	000		
DECAL-TERMINAL BLOCK-LEFT	079046-23L		1	000		
DECAL-TERMINAL BLOCK-RIGHT	079046-23R		1	000		
DIAGRAM-WIRING	074063-	1	1	000	J9054573/UP	143
DIAGRAM-WIRING	079691-	1	1	000	J710000 TO J9054573	122
DIAGRAM-WIRING	078807-	1	1	000	PRIOR TO J7100000	122

+ Available Separately

DESCRIPTION	PART NUMBER	QS12 QTY.	QS24 QTY.	WARR. CLASS	REMARKS	PARTS UPDATE
GASKET-ACCESS COVER	074059		1	000	J9054573/UP	143
HARNESS-CONTROL TO REMOTE QS24	078618	1	2	103	CONTROL BOARD TO REMOTE KEY PAD BOX	
HARNESS-T/C LOWER *QS12*	079292	1		103	THERMOCOUPLES (6 LOWER COOKING ZONES) REPLACE WITH 074178 - T/C LOWER FRONT QS, 074179 - T/C LOWER MIDDLE QS, 074180 - T/C LOWER REAR QS AS REQUIRED OR ALL 3 TO REPLACE HARNESS.	
HARNESS-T/C LOWER *QS24*	078643		1	103	THERMOCOUPLES (6 LOWER COOKING ZONES) REPLACE WITH 074178 - T/C LOWER FRONT QS, 074179 - T/C LOWER MIDDLE QS, 074180 - T/C LOWER REAR QS AS REQUIRED OR ALL 3 TO REPLACE HARNESS.	
HARNESS-T/C UPPER #4	078622-4	1	1	103	THERMOCOUPLES (UPPER PLATEN ASSY.)	
HARNESS-T/C UPPER #5	078622-5	1	1	103	THERMOCOUPLES (UPPER PLATEN ASSY.)	
HARNESS-T/C UPPER #6	078622-6	1	1	103	THERMOCOUPLES (UPPER PLATEN ASSY.)	
HARNESS-WIRE-LOWER POWER	074006	1	2	103	J9054573/UP	143
+CONNECTOR-HOUSING 3 PIN	078596	1	2	103		
HARNESS-WIRE-LOWER POWER*QS24* (OLD)	078620	1	2	103	POWER SWITCH TO INTERFACE BOARD (PRIOR TO J9054573)	143
HARNESS-WIRE-UPPER POWER	074007	1	1	103	1 PER UPPER PLATEN	
HEATER-CAST - 1800 WATT	079639-	3	6	103	J7100000/UP	122
HEATER-CAST - 1400 WATT	078409-	3	6	103	PRIOR TO J7100000	122
KIT A.-T-HANDLE *QS12-QS24*	X74326-KIT	1	1	103		
+WASHER	078638	1	1	000		
KIT A.-RELAY BOX A. (60HZ-OLD)	X79897-SER			103	USE X74036-SER	135/143
LABEL-CAUTION-HOT SYMBOL	075717-SYM	1	1	000	J9080000 TO K0100000	
LABEL-PRODUCT	079714	1	1	000		
LABEL-PRODUCT STOP BULLS EYE	079894	1		000	GROOVED PLATEN ONLY	
LABEL-WARN-NO SPRAY SURFACE-SYM	074148-SYM	1	2	000	J9110000/UP	
LEG-4"-3/8-16 STUD	036397	4	4	103		
MAN-OPER QS24	050559-M	1	1	000		
PANEL A.-CONTROL *QS12*	X79265	1		103		
PANEL A.-CONTROL *QS24*	X78405	1	1	103		

+ Available Separately

DESCRIPTION	PART NUMBER	QS12 QTY.	QS24 QTY.	WARR. CLASS	REMARKS	PARTS UPDATE
PANEL A.-SIDE LEFT	NONE				NOT AVAILABLE FOR REPLACEMENT - SEALED	
PANEL A.-SIDE RIGHT	NONE				UNIT TO PREVENT GREASE MIGRATION	
PANEL-REAR *QS12*	079280	1		103		
PANEL-REAR *QS24*	079044		1	103		
PARTITION A.-GREASE	X79944	1	1	103	Replaces X78402	137
GASKET -GREASE PARTITION	074154	1	1	000	J9101783/UP (CAN ADAPT TO EXISTING MODELS)	147
PIN-LOCATING	078544	4	4	103		
PIVOT A.-PLATEN COMPLETE *QS24	X78758-SER	1	1	103		
ARM-PLATEN *QS24*	078520	2	2	103		
ARM-PLATEN LINKAGE *QS24*	079192	2	2	103		
BEARING-CYL MOUNT *QS24*	079214	2	2	103		
BEARING-LINKAGE ARM *QS24*	079213	2	2	103		
BEARING-OPEN END NEEDLE *QS24*	078522	8	8	103		
BEARING-OPEN END NEEDLE *QS24*	078523	2	2	103		
BEARING-OPEN END NEEDLE *QS24*	078652	2	2	103		
BEARING-PLATEN ARM PIVOT QS24	078541	2	2	103		
CAP-BEARING PLATEN ARM *QS24*	078548	2	2	103		
CYLINDER-GAS DUEL SEAL QS24	074313	2	2	103	REPLACES 079215	
E-RING 3/4	077046	4	4	000		
E-RING 3/8	038958	16	16	000		
E-RING EXTERNAL 1/2	024908	16	16	000		
HANDLE-PLATEN LIFT *QS24*	078592	1	1	103		
LINKAGE-PIVOT UPPER *QS24*	078760	2	2	103		
MOUNT-CYLINDER LIFT *QS24*	079193	1	1	103		
PIN-LINKAGE ARM *QS24*	078664	2	2	103		
PIVOT A.-PLATEN *QS24*	X78759	1	1	103		
PIVOT-PLATEN ARM *QS24*	078556	2	2	103		
PLATE-PLATED LINKAGE PIVOT LH	078560	1	1	103		
PLATE-PLATED LINKAGE PIVOT RH	078559	1	1	103		
RETAINER-BEARING *QS24*	079191	2	2	103		
ROD-LINKAGE 3/4 DIA *QS24*	079216	1	1	103	ROD W/GEAR UNIT	

+ Available Separately

DESCRIPTION	PART NUMBER	QS12 QTY.	QS24 QTY.	WARR. CLASS	REMARKS	PARTS UPDATE
ROD-PLATEN LINKAGE MID *QS24	079194	1	1	103		
ROD-PLATEN LINKAGE MID *QS24*	078549	1	1	103		
ROD-PLATEN LINKAGE UPPER *QS24	078550	1	1	103		
PLATEN ASSEMBLY 208V 1400W	X79629-23	1	1	212	208VOLT - 60HZ	123
PLATEN ASSEMBLY 208/230V 1400W	X79629-33	1	1	212	208-230VOLT - 60HZ	123
SCRAPER-TEFLON WIPER	075887	1	1	000		
SCRAPER-TROUGH	079726	1	1	000		
SCREW-10-32X1/2 THUMB STAINLES	078651	2	2	103	THUMB SCREWS	
SHEET-SEAMED RELEASE *QS24*	078804	2	2	000		
SHIELD-GREASE FRONT *QS24*	079433	1	1	103		
SHIELD-GREASE REAR *QS24*	079434	1	1	103		
SLIDE A.-GAP - FRONT	X78864-F	1	1	103	1 PER PLATEN	
PIN-GAP-SLIDE-ADJ.	078789	2	2	103		
SCREW-1/4-20X1/4 ALLEN SET	001801	2	2	000		
SCREW-10-24 X 3/8 SET SS	078863	2	2	000	PRIOR TO J8020000	
SLIDE A.-GAP - REAR	X78864-R	1	1	103	1 PER PLATEN	
PIN-GAP-SLIDE-ADJ.	078789	2	2	103		
SCREW-1/4-20X1/4 ALLEN SET	001801	2	2	000		
SCREW-10-24 X 3/8 SET SS	078863	2	2	000	PRIOR TO J8020000	
SPRING .375 OD X .037 X 1.500	079704	2	2	103	RELEASE BAR (Replaces 078805)	125
SPRING-3/16 BELLEVILLE DISC	079127	2	2	103	PRIOR TOJ7010000	
STANDOFF-FRONT	079289	4	2	103		
STANDOFF-REAR	079288	2	2	103		
SWITCH-ROCKER SPST OFF-ON	078418	1	2	103	POWER	
THERMOSTAT-475F	078410	3	6	103		
TRANS.-CONT.-40VA 120/200/240V	045754	1	2	103		
TRAY A.-GREASE *QS24*	X79940-SER	1	1	103	Replaces X78428	137
T/C LOWER FRONT QS	074178	1	1	103	THERMOCOUPLE - REPLACES 079292 OR 078643 HARNESS	
T/C LOWER MIDDLE QS	074179	1	1	103	THERMOCOUPLE - REPLACES 079292 OR 078643 HARNESS	
T/C LOWER REAR QS	074180	1	1	103	THERMOCOUPLE - REPLACES 079292 OR 078643 HARNESS	
VIDEO-TRAIN QS12 & QS24 OPERATIONS	051170-V	1	1	000		

+ Available Separately

DESCRIPTION	PART NUMBER	QS12 QTY.	QS24 QTY.	WARR. CLASS	REMARKS	PARTS UPDATE
WIPER-SIDE LEFT *QS24*	079437	1	1	103		
WIPER-SIDE RIGHT *QS24*	079438	1	1	103		
WIPER-FRONT *QS24*	079439	1	1	103		
WIPER-REAR *QS24*	079440	1	1	103		
ACCESSORIES:						
SCRAPER A.-GROOVE - RUBBER	X79246	1	1	103	RUBBER - FOR GROOVED PLATEN	
SCRAPER A.-GROOVE-METAL	X79668	1	1	103	METAL - FOR GROOVED PLATEN	
OPTIONS:						
CART-SEE BREAKDOWN						
BRACKET A.-LEG SUPPORT	X79994	4		103		
CASTER-SWIVEL 3/4-10	021279	2	2	103		
CASTER-LOCKING 3/4-10	030307	2	2	103		
LEG-INSERT	079990	4	4	103		
PIN-LEG HEIGHT	079991	4	4	103		
KIT A.-PRODUCT STOP	X79916	1	1	103		
KIT A.-REAR COVER STOP BAR	X79689	1		103	HOOD STOP	
KIT A.-REAR COVER STOP BAR	X79873		1	103	HOOD STOP - 2 PLATENS	
KIT A.-REAR COVER STOP BAR LH	X79900		1	103	HOOD STOP - LEFT PLATEN	
KIT A.-REAR COVER STOP BAR RH	X79902		1	103	HOOD STOP - RIGHT PLATEN	
LEG-2-1/2 IN 3/8-16 STUD	079715	4	4	103	DISCONTINUED	
50HZ						
BOX A.-RELAY (OLD)	X79678-75	1	2	212	50HZ & 60HZ USE X74036-SER	143
RELAY-SPST-200/240VAC (OLD)	079690	6	6	103		
BLOCK-TERMINAL-5P SCREW W/JUMPERS	X79839-62R		1	103	RIGHT SIDE - J8050000/UP	
BLOCK-TERMINAL-5P SCREW	079045-62R		1	103	RIGHT SIDE - PRIOR TO J8050000	
DECAL-SWITCH *QS24* SYMBOL	079454	1	2	000		
DECAL-TERMINAL BLOCK *QS24	079046-62L		1	000		
DECAL-TERMINAL BLOCK *QS24	079046-62R		1	000		
CONTROL-HI-LIMIT 550F NO RESET	074165	12	12	103	K0010000/ UP	

+ Available Separately

DESCRIPTION	PART NUMBER	QS12 QTY.	QS24 QTY.	WARR. CLASS	REMARKS	PARTS UPDATE
DIAGRAM-WIRING (NEW)	074063-75	1	1	000	J9054573/UP	143
DIAGRAM-WIRING (OLD)	079691-75	1	1	000		
FILTER A.-*M22*	X79163	1	1	103		
HARNES-POWER LOWER *QS24* (NEW)	074065	1	2	103	J9054573/UP	
HARNES-POWER LOWER *QS24* (OLD)	079496	1	2	103		
HARNES-POWER UPPER (NEW)	074007	1	1	103	1 PER PLATEN (REPLACES 079497)	
HEATER-CAST 230V 1800W *QS24*	079639-26	3	6	103		
PLATEN ASSEMBLY 230/400V 1400W	X79629-75	1	1	212	230/400VOLT - 50HZ	123
THERMOSTAT-500F	079471	12	12	103	PRIOR TO K0010000 - UPDATE W/QS12-X74189; QS24-X74190 (FLAT), X74188 (SINGLE CLAM), OR X74186 (DUAL CLAM)	150
VIDEO-TRAIN QS24 OPS	051170-PAL	1	1	000		

+ Available Separately

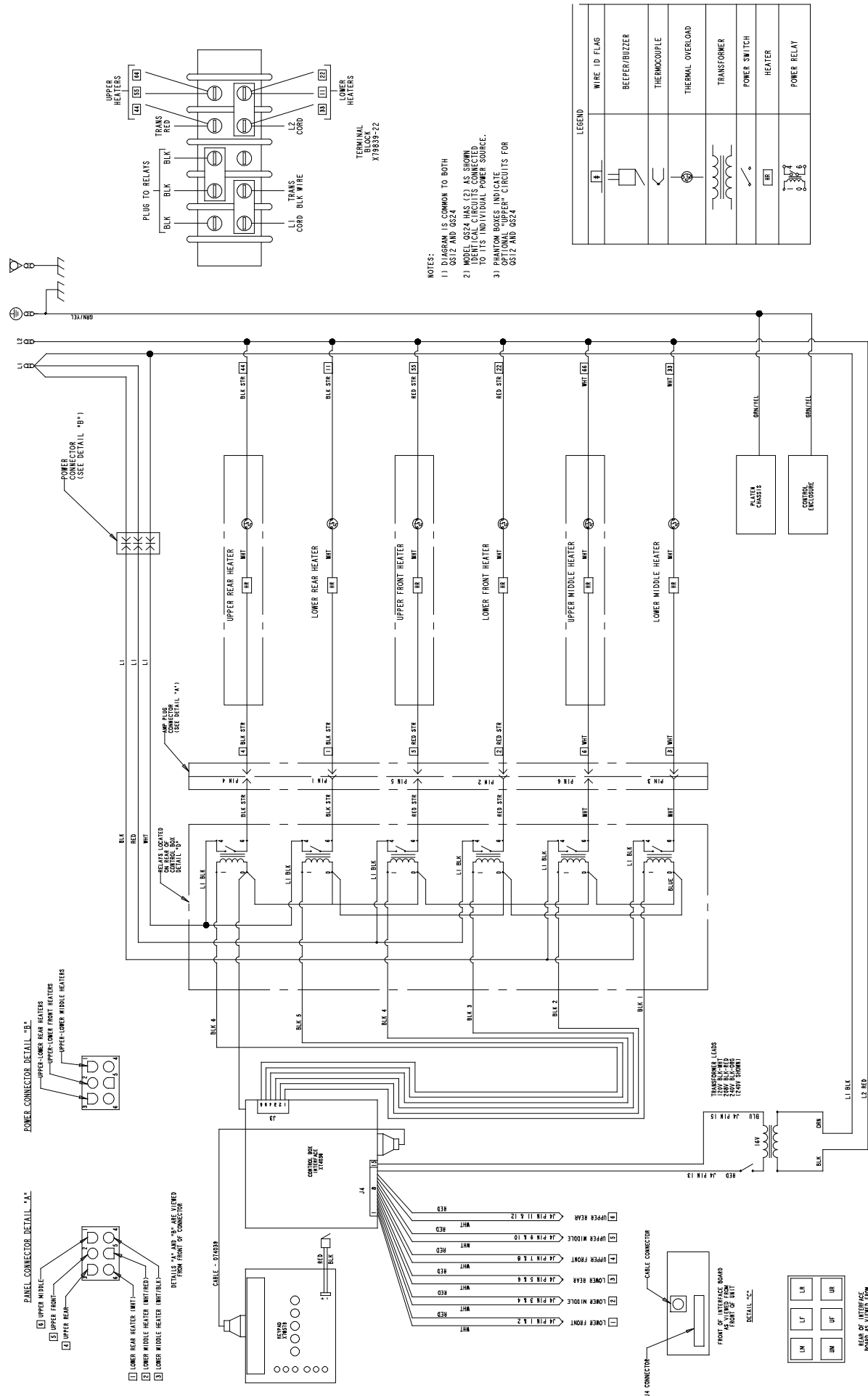

NOTES:
 1) DIAGRAM IS COMMON TO BOTH QS12 AND QS24
 2) IDENTICAL CIRCUITS CONNECTED TO ITS INDIVIDUAL POWER SOURCE.
 3) PHANTOM BOXES INDICATE OPTIONAL "UPPER" CIRCUITS FOR QS12 AND QS24

LEGEND	
	WIRE ID FLAG
	BEEPER/BUZZER
	THERMOCOUPLE
	THERMAL OVERLOAD
	TRANSFORMER
	POWER SWITCH
	HEATER
	POWER RELAY

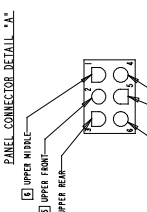
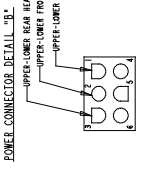

1) LOWER REAR HEATER (WHT)
 2) LOWER MIDDLE HEATER (WHT/BLK)
 3) LOWER FRONT HEATER (WHT)
 4) UPPER REAR
 5) UPPER FRONT
 6) UPPER MIDDLE
 7) UPPER LOWER REAR HEATERS
 8) UPPER LOWER FRONT HEATERS
 9) UPPER LOWER MIDDLE HEATERS

TRANSFORMER LEADS
 240V BLK, RED
 120V WHT, BLK
 124V WHT



QS12/24
 074063-22

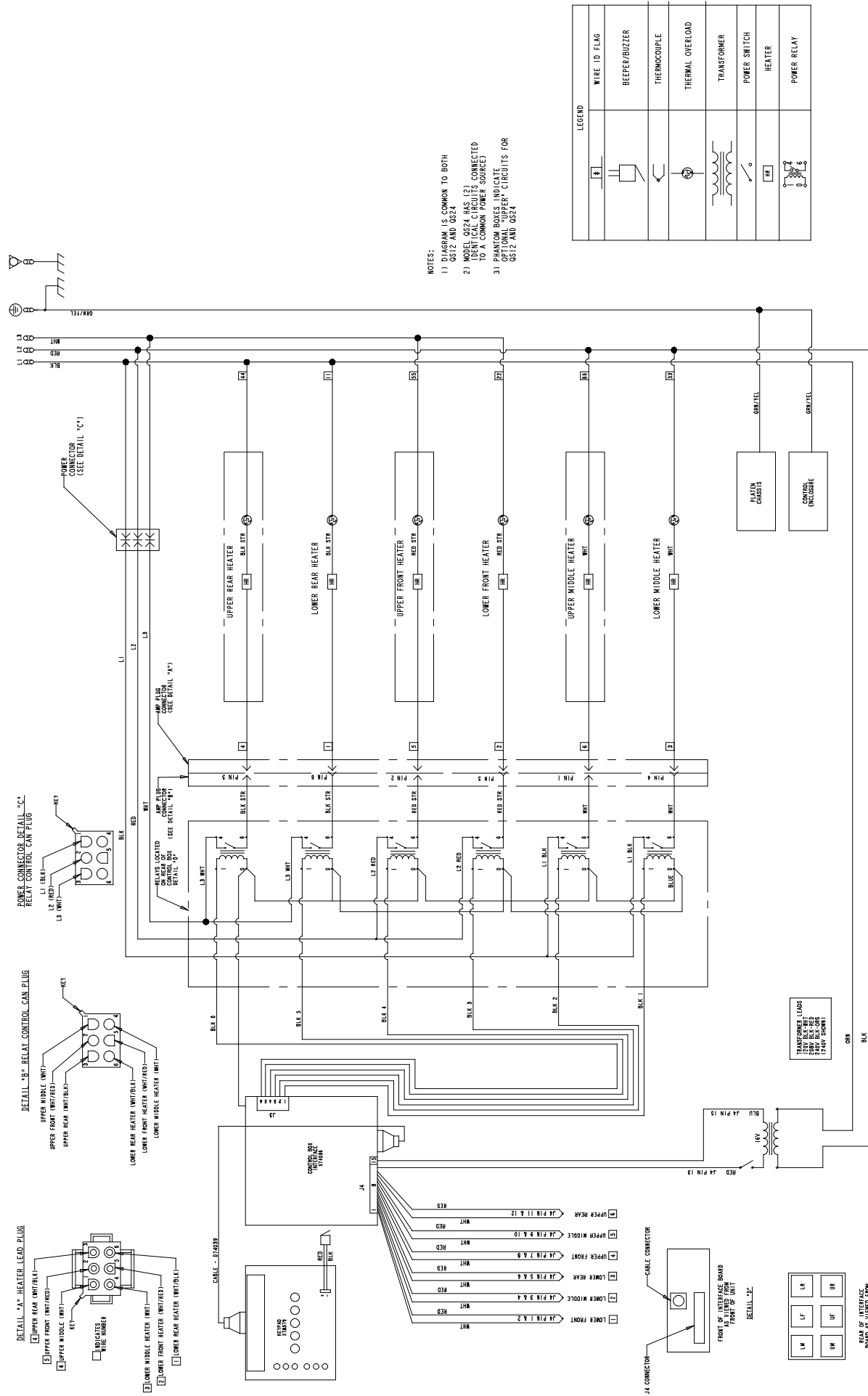

- NOTES:
- 1) DIAGRAM IS COMMON TO BOTH QS12 AND QS24
 - 2) WIRE AND WIRE ID FLAG IDENTIFICATION (C) IDENTICAL CIRCUITS CONNECTED TO A COMMON POWER SOURCE
 - 3) PHANTOM BOXES INDICATE OPTIONAL "UPPER" CIRCUITS FOR QS12 AND QS24

WIRE ID FLAG	LEGEND
BE	BEEPER/BUZZER
TC	THERMOCOUPLE
TO	THERMAL OVERLOAD
TR	TRANSFORMER
PS	POWER SWITCH
HE	HEATER
PR	POWER RELAY

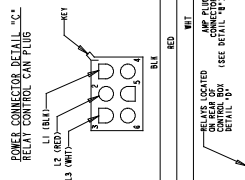
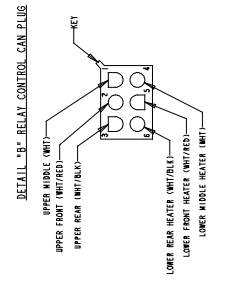
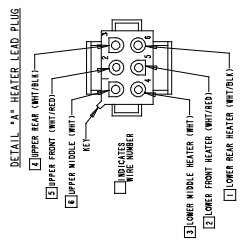

TRANSFORMER LOADS
250V 50/60 HZ
200W 2.0A
240V 1.67A

QS12/24
074063-23

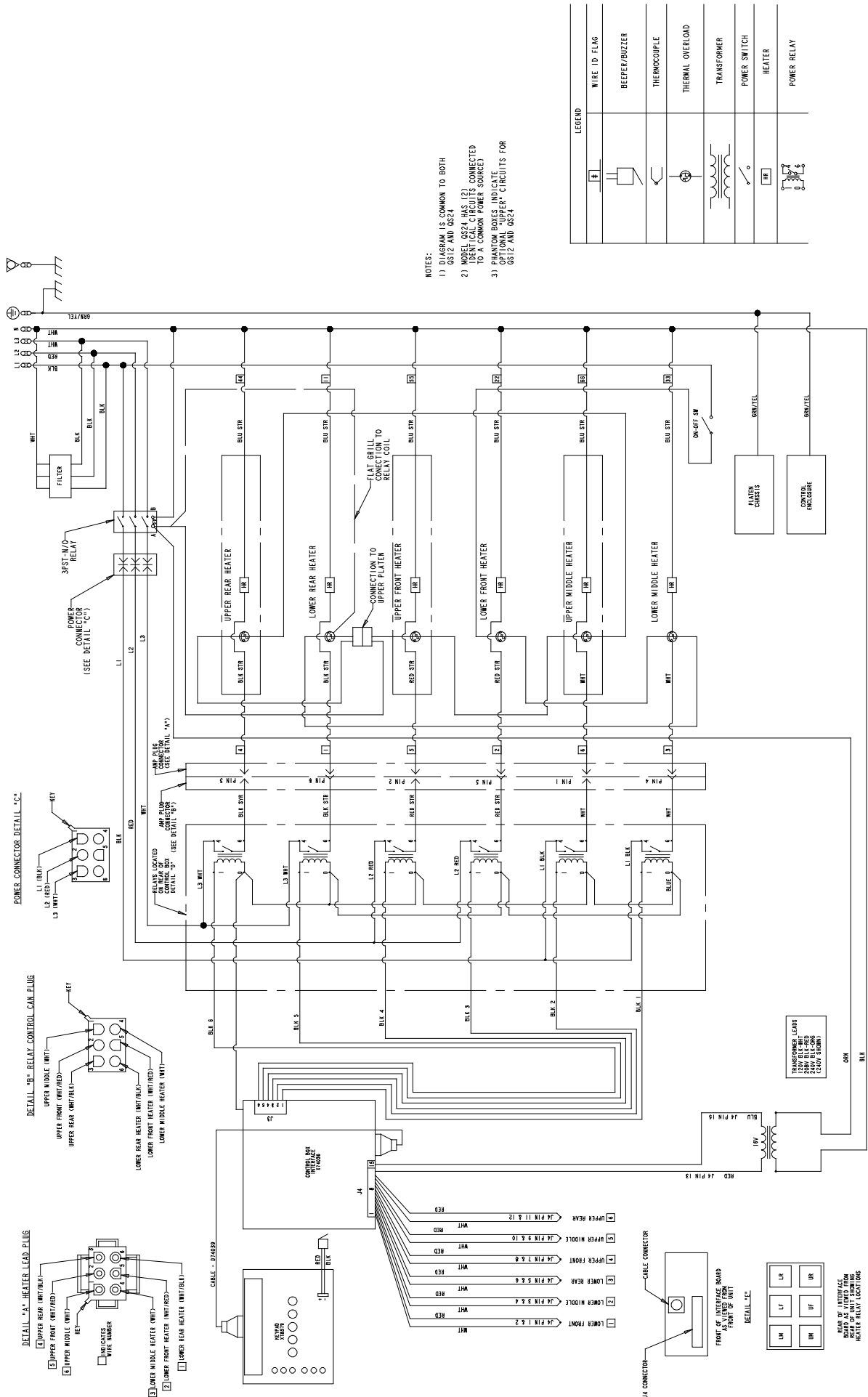

- NOTES:
- 1) DIAGRAM IS COMMON TO BOTH QS12 AND QS24
 - 2) MODEL QS24 HAS (2) IDENTICAL CIRCUITS CONNECTED TO A COMMON POWER SOURCE
 - 3) PHANTOM BOXES INDICATE OPTIONAL UPPER* CIRCUITS FOR QS12 AND QS24

LEGEND	
	WIRE ID PLUG
	BEEPER/BUZZER
	THERMOCOUPLE
	THERMAL OVERLOAD
	TRANSFORMER
	POWER SWITCH
	HEATER
	POWER RELAY

POWER CONNECTOR DETAIL "C"

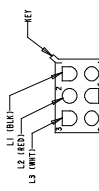

DETAIL "P" - RELAY CONTROL CAN PLUS

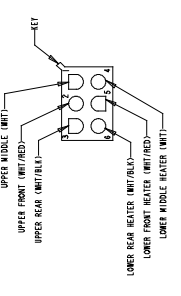

DETAIL "A" - HEATER LEAD PLUS

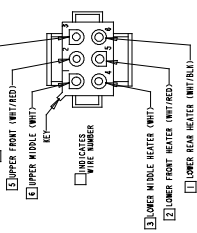

TRANSFORMER LEADS
200V BLK-RED
240V BLK-RED
(240V SHOWN)

WHT IS WIRE FOR
BOARD AS WIRE FOR
REAR UNIT LEADING
FROM BOARD

DETAIL "D"

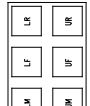

QS12/24
074063-75
Rev. 4/01

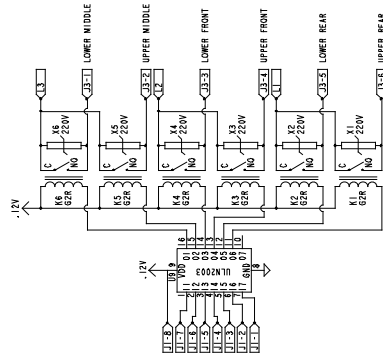
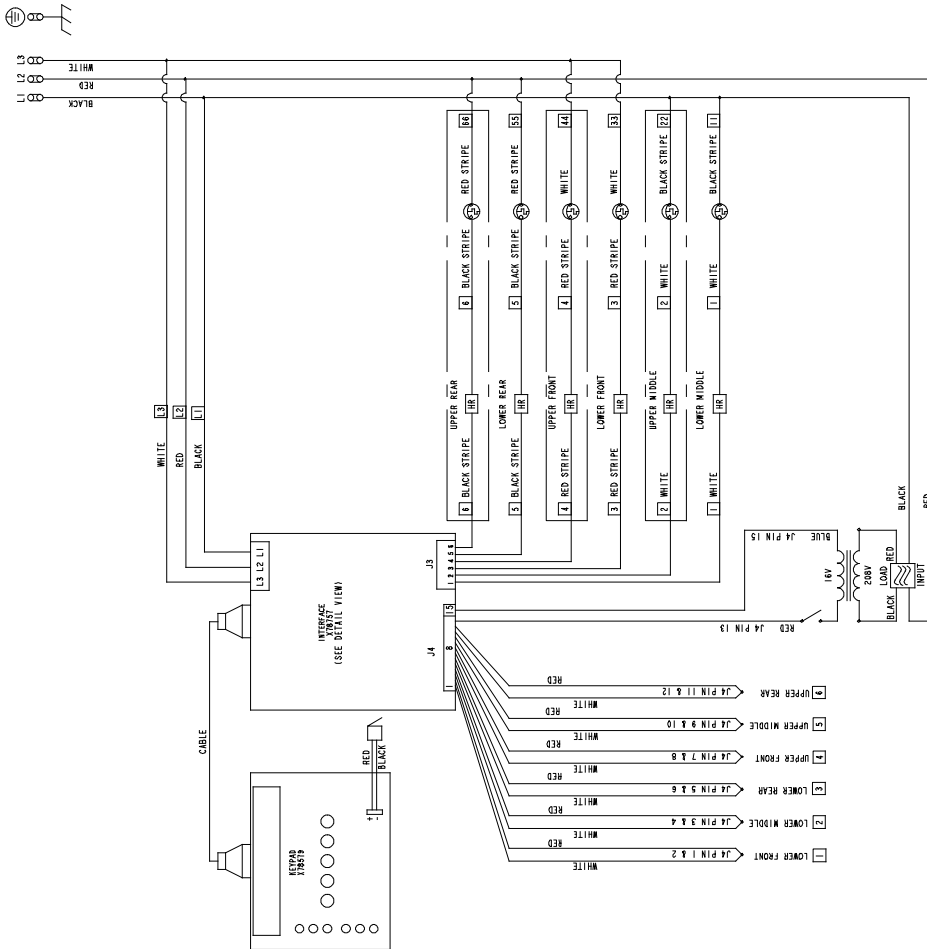

DETAIL VIEW OF INTERFACE OF OUTPUT TO HEATER CIRCUITS

LEGEND	
	WIRE ID FLAG
	BEEPER/BUZZER
	THERMOCOUPLE
	THERMAL OVERLOAD
	FILTER
	TRANSFORMER
	POWER SWITCH
	HEATER

NOTES:
 1) DIAGRAM IS COMMON TO BOTH QS12 AND QS24
 2) PHANTOM BOXES INDICATE OPTIONAL "UPPER"
 3) PHANTOM BOXES INDICATE OPTIONAL "UPPER"
 CIRCUITS ON QS12 AND QS24

QS24
078807-23

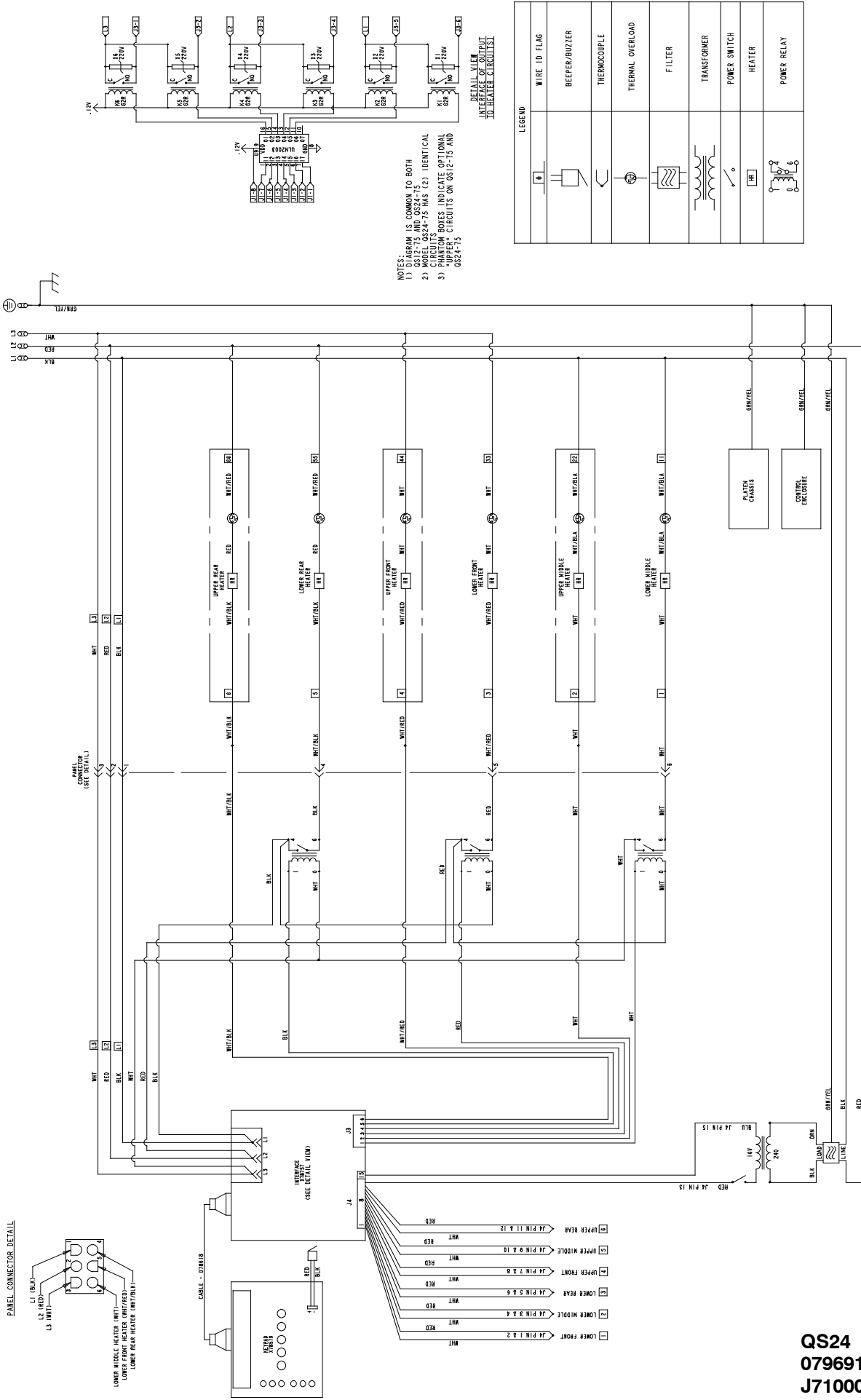

NOTES:
 1) DIAGRAM IS COMMON TO BOTH
 2) MODEL QS12-75 AND QS24-75
 3) PHANTOM BOXES INDICATE OPTIONAL
 "UPPER" CIRCUITS ON QS12-75 AND
 QS24-75

LEGEND	WIRE ID FLAG
	BEEPER/BUZZER
	THERMOCOUPLE
	THERMAL OVERLOAD
	FILTER
	TRANSFORMER
	POWER SWITCH
	HEATER
	POWER RELAY

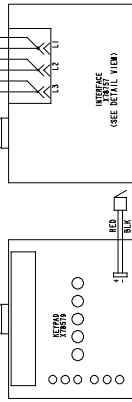
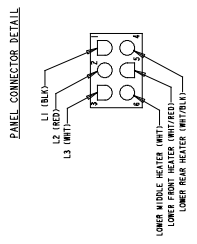

QS24
079691-77
J710000 - J9050000

Free Manuals Download Website

<http://myh66.com>

<http://usermanuals.us>

<http://www.somanuals.com>

<http://www.4manuals.cc>

<http://www.manual-lib.com>

<http://www.404manual.com>

<http://www.luxmanual.com>

<http://aubethermostatmanual.com>

Golf course search by state

<http://golfingnear.com>

Email search by domain

<http://emailbydomain.com>

Auto manuals search

<http://auto.somanuals.com>

TV manuals search

<http://tv.somanuals.com>