



# Installation, Start-Up, and Service Instructions

## CONTENTS

	Page		Page
<b>SAFETY CONSIDERATIONS</b> .....	1,2	<b>Units with Aquazone™ Complete C Control</b> .....	40
<b>GENERAL</b> .....	2	<b>Units with Aquazone Deluxe D Control</b> .....	40
<b>INSTALLATION</b> .....	2-34	<b>Units with WSHP Open Protocol</b> .....	40
<b>Step 1 — Check Jobsite</b> .....	2	<b>SYSTEM TEST</b> .....	43-45
<b>Step 2 — Check Unit</b> .....	2	<b>Test Mode</b> .....	43
• STORAGE		<b>Retry Mode</b> .....	43
• PROTECTION		<b>Aquazone Deluxe D Control LED Indicators</b> .....	45
• INSPECT UNIT		<b>WSHP Open Test Mode</b> .....	45
<b>Step 3 — Locate Unit</b> .....	3	<b>SERVICE</b> .....	45,46
<b>Step 4 — Mount the Unit</b> .....	8	<b>Filters</b> .....	45
<b>Step 5 — Install Condensate Drain</b> .....	8	<b>Water Coil</b> .....	45
<b>Step 6 — Make Piping Connections</b> .....	8	<b>Condensate Drain Pans</b> .....	45
• WATER LOOP APPLICATIONS		<b>Refrigerant System</b> .....	45
• GROUND-WATER APPLICATIONS		<b>Condensate Drain Cleaning</b> .....	45
• GROUND-LOOP APPLICATIONS		<b>Air Coil Cleaning</b> .....	45
<b>Step 7 — Connect Electrical Wiring</b> .....	9	<b>Condenser Cleaning</b> .....	45
• SUPPLY VOLTAGE		<b>Checking System Charge</b> .....	46
• 208-VOLT OPERATION		<b>Refrigerant Charging</b> .....	46
• BLOWER SELECTION		<b>Air Coil Fan Motor Removal</b> .....	46
<b>Step 8 — Connect Low Voltage Wiring</b> .....	34	<b>Replacing the WSHP Open Controller's Battery</b> .....	46
• THERMOSTAT CONNECTIONS		<b>TROUBLESHOOTING</b> .....	47-49
• WATER FREEZE PROTECTION		<b>Thermistor</b> .....	47
• AIR COIL FREEZE PROTECTION		<b>Control Sensors</b> .....	47
• ACCESSORY CONNECTIONS		<b>APPENDIX A — WSHP OPEN SCREEN CONFIGURATION</b> .....	50-55
• WATER SOLENOID VALVES		<b>START-UP CHECKLIST</b> .....	CL-1, CL-2
<b>PRE-START-UP</b> .....	35		
<b>System Checkout</b> .....	35		
<b>FIELD SELECTABLE INPUTS</b> .....	35,36		
<b>Complete C Control Jumper Settings</b> .....	35		
<b>Complete C Control DIP Switches</b> .....	35		
<b>Deluxe D Control Jumper Settings</b> .....	35		
<b>Deluxe D Control DIP Switches</b> .....	35		
<b>Deluxe D Control Accessory Relay Configurations</b> .....	36		
<b>Water Valve (Slow Opening)</b> .....	36		
<b>Outside-Air Damper (OAD)</b> .....	36		
<b>START-UP</b> .....	36-40		
<b>Operating Limits</b> .....	37		
<b>Scroll Compressor Rotation</b> .....	37		
<b>Unit Start-Up Cooling Mode</b> .....	37		
<b>Unit Start-Up Heating Mode</b> .....	37		
<b>Unit Start-Up with WSHP Open Controls</b> .....	38		
<b>Flow Regulation</b> .....	39		
<b>System Claening and Flushing</b> .....	39		
<b>Antifreeze</b> .....	39		
<b>Cooling Tower/Boiler Systems</b> .....	40		
<b>Ground Coupled, Closed Loop and Plateframe Heat Exchanger Well Systems</b> .....	40		
<b>OPERATION</b> .....	40-43		
<b>Power Up Mode</b> .....	40		

**IMPORTANT:** Read the entire instruction manual before starting installation.

### SAFETY CONSIDERATIONS


Installation and servicing of air-conditioning equipment can be hazardous due to system pressure and electrical components. Only trained and qualified service personnel should install, repair, or service air-conditioning equipment.

Untrained personnel can perform basic maintenance functions of cleaning coils and filters and replacing filters. All other operations should be performed by trained service personnel. When working on air-conditioning equipment, observe precautions in the literature, tags and labels attached to the unit, and other safety precautions that may apply.

Improper installation, adjustment, alteration, service, maintenance, or use can cause explosion, fire, electrical shock or other conditions which may cause personal injury or property damage. Consult a qualified installer, service agency, or your distributor or branch for information or assistance. The qualified installer or agency must use factory-authorized kits or accessories when modifying this product. Refer to the individual instructions packaged with the kits or accessories when installing.

Follow all safety codes. Wear safety glasses and work gloves. Use quenching cloth for brazing operations. Have fire extinguisher available. Read these instructions thoroughly and follow all warnings or cautions attached to the unit. Consult local building codes and the National Electrical Code (NEC) for special installation requirements.

Understand the signal words — DANGER, WARNING, and CAUTION. DANGER identifies the most serious hazards which will result in severe personal injury or death. WARNING signifies hazards that could result in personal injury or death. CAUTION is used to identify unsafe practices, which would result in minor personal injury or product and property damage.

Recognize safety information. This is the safety-alert symbol (). When you see this symbol on the unit and in instructions or manuals, be alert to the potential for personal injury.

### WARNING

Electrical shock can cause personal injury and death. Shut off all power to this equipment during installation. There may be more than one disconnect switch. Tag all disconnect locations to alert others not to restore power until work is completed.

### CAUTION

This system uses R-410A, which has higher pressures than R-22 and other refrigerants. No other refrigerant may be used in this system. Suction tubing design pressure is 445 psig (3068 kPa) and liquid tubing design pressure is 656 psig (4522 kPa). Failure to use gage set, hoses, and recovery systems designed to handle R-410A refrigerant may result in personal injury and equipment damage. If unsure about equipment, consult the equipment manufacturer.

## GENERAL

This Installation and Start-Up Instructions literature is for Aqazone™ rooftop water source heat pump systems.

Rooftop water source heat pumps (WSHP) are single-package outdoor units with electronic controls designed for year-round cooling and heating.

**IMPORTANT:** The installation of water source heat pump units and all associated components, parts, and accessories which make up the installation shall be in accordance with the regulations of ALL authorities having jurisdiction and MUST conform to all applicable codes. It is the responsibility of the installing contractor to determine and comply with ALL applicable codes and regulations.

## INSTALLATION

**Step 1 — Check Jobsite** — Installation, operation and maintenance instructions are provided with each unit. Before unit start-up, read all manuals and become familiar with the unit and its operation. Thoroughly check out the system before operation. Complete the inspections and instructions listed below to prepare a unit for installation. See Table 1 for unit physical data.

### CAUTION

To avoid equipment damage, do not use these units as a source of heating or cooling during the construction process. The mechanical components and filters used in these units quickly becomes clogged with construction dirt and debris which may cause system damage.

**Step 2 — Check Unit** — Upon receipt of shipment at the jobsite, carefully check the shipment against the bill of lading. Make sure all units have been received. Inspect the carton or crating of each unit, and inspect each unit for damage. Ensure the shipping company makes proper notation of any shortages or damage on all copies of the freight bill. Concealed damage not discovered during unloading must be reported to the shipping company within 15 days of receipt of shipment.

**NOTE: It is the responsibility of the purchaser to file all necessary claims with the shipping company.**

1. Verify unit is correct model for entering water temperature of job.
2. Be sure to provide freeze protection for piping, as required. Well water applications are especially susceptible to freezing.
3. Be sure the installation location is isolated from sleeping areas, private offices and other acoustically sensitive spaces.
4. Check local codes to be sure a secondary drain pan is not required under the unit.
5. Be sure unit is mounted at a height sufficient to provide an adequate slope of the condensate lines. If an appropriate slope cannot be achieved, a field-supplied condensate pump may be required.
6. Provide sufficient space for duct connection.
7. Provide adequate clearance for filter replacement and drain pan cleaning. Do not allow piping, conduit, etc. to block filter access.
8. Provide sufficient access to allow maintenance and servicing of the fan and fan motor, compressor and coils.
9. Provide an unobstructed path to the unit. Space should be sufficient to allow removal of unit if necessary.
10. Provide ready access to water valves and fittings, and screwdriver access to unit side panels, discharge collar, and all electrical connections.
11. Where access to side panels is limited, pre-removal of the control box side mounting screws may be necessary for future servicing.

**STORAGE** — If the equipment is not installed immediately upon its arrival at the jobsite, it should be left in its shipping carton and stored in a clean, dry area of the building or in a warehouse. Units must be stored in an upright position at all times. If unit stacking is necessary, stack 50RTP03-10 units a maximum of 2 high. Do not stack units larger than 50RTP10. Do not remove any equipment from its shipping package until it is needed.

**PROTECTION** — Once the units are properly positioned on the jobsite, they must be covered with either a shipping carton, vinyl film, or an equivalent protective covering. Open ends of pipes stored on the jobsite must be capped. This precaution is especially important in areas where painting, plastering, or spraying of fireproof material, etc. is not yet complete. Foreign material that is allowed to accumulate within the units can prevent proper start-up and necessitate costly clean-up operations.

Before installing any of the system components, be sure to examine each pipe, fitting, and valve, and remove any dirt or foreign material found in or on these components.

**⚠ CAUTION**

DO NOT store or install units in corrosive environments or in locations subject to temperature or humidity extremes (e.g., attics, garages, rooftops, etc.). Corrosive conditions and high temperature or humidity can significantly reduce performance, reliability, and service life. Always move units in an upright position. Tilting units on their sides may cause equipment damage.

**INSPECT UNIT** — To prepare the unit for installation, complete the procedures listed below:

1. Compare the electrical data on the unit nameplate with ordering and shipping information to verify that the correct unit has been shipped.
2. Verify that the unit is the correct model for the entering water temperature of the job.
3. Do not remove the packaging until the unit is ready for installation.
4. Verify that the refrigerant tubing is free of kinks or dents, and that it does not touch other unit components.

5. Inspect all electrical connections. Be sure connections are clean and tight at the terminals.
6. Compressors are internally spring-mounted. Compressors equipped with external spring vibration isolators must have bolts loosened and shipping clamps removed.
7. Remove any blower support cardboard from inlet of the blower if present.
8. Locate and verify any accessory kit located in compressor section.
9. Remove any access panel screws that may be difficult to remove once unit is installed.

**Step 3 — Locate Unit** — The following guidelines should be considered when choosing a location for WSHP. Refer to Fig. 1-3 for unit dimensional data. See Fig. 4 for accessory roof curb dimensional data.

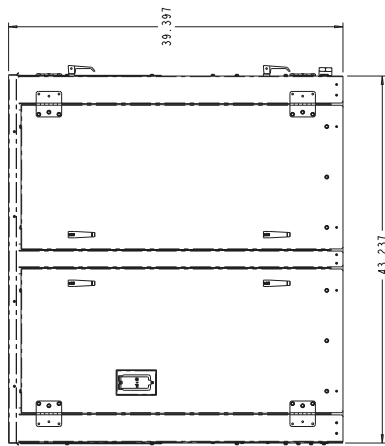
- Provide sufficient space for water, electrical and duct connections
- Locate unit in an area that allows for easy access and removal of filter and access panels
- Allow enough space for service personnel to perform maintenance

**Table 1 — Physical Data — Aquazone™ 50RTP03-20 Units**

UNIT 50RTP	03	04	05	06	08	10	12	14	20
<b>Compressor (qty)</b>	Scroll (1)				Scroll (2)				
<b>Factory Charge R-410A (oz)</b>	64	84	120	132	108	120	130	192	300
<b>Blower Motor</b>									
<b>Motor Quantity</b>	1								
<b>Standard Motor (hp)</b>	1	1	1	1.5	2	3	3	3	5
<b>Large Motor (hp)</b>	N/A	1.5	1.5	2	3	5	5	5	7.5
<b>Blower(s)</b>									
<b>Number of Blowers</b>	1				2				
<b>Blower Wheel Size (dia x w)</b>	10 x 6		2 x 12		15 x 11		15 x 15		15 x 11
<b>V-belt size, Std drive</b>	A29	A30	A32	AX33	B40	BX42	BX46	B39	BX40
<b>Water Connection Size</b>									
<b>IPT (in.)</b>	3/4		1	1 1/4	1 1/2			2	
<b>Coax Volume</b>									
<b>Volume (US Gallons)</b>	0.61	0.77	1.11	1.30	1.69	2.29	2.68	3.83	4.77
<b>Condensate Connection Size</b>									
<b>FPT (in.)</b>	1								
<b>Air Coil Data</b>									
<b>Air Coil Total Face Area (sq ft)</b>	5		7		9.33	10.5		20	
<b>Filter, Standard, Qty...Size (in.)</b>	4...16 x 20				6...16 x 20			8...16 x 20, 2...20 x 20	
<b>Operating Weight (lb)</b>	735	785	835	880	1080	1125	1175	1770	1960
<b>Shipping Weight (lb)</b>	750	800	850	900	1100	1150	1200	1800	2000
<b>Corner Weights (lb)</b>									
<b>Front-Left</b>	184	196	208.5	224	292	303.5	320	479	530
<b>Front-Right</b>	259	276	293.5	298	380	395.5	406	623	690
<b>Rear-Left</b>	108.5	117	124.5	134	193	202	212.5	315	350
<b>Rear-Right</b>	183.5	196	208.5	224	215	224	236.5	353	390
<b>Curb, Installed (lb)</b>	83				94			128	

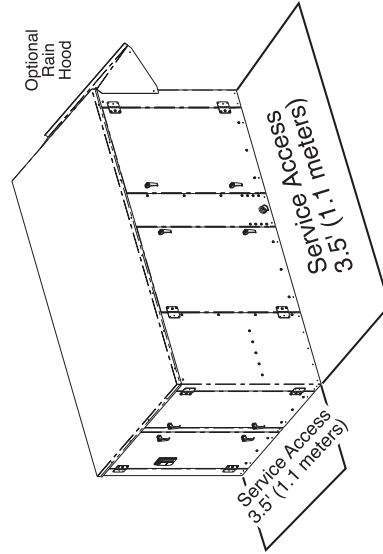
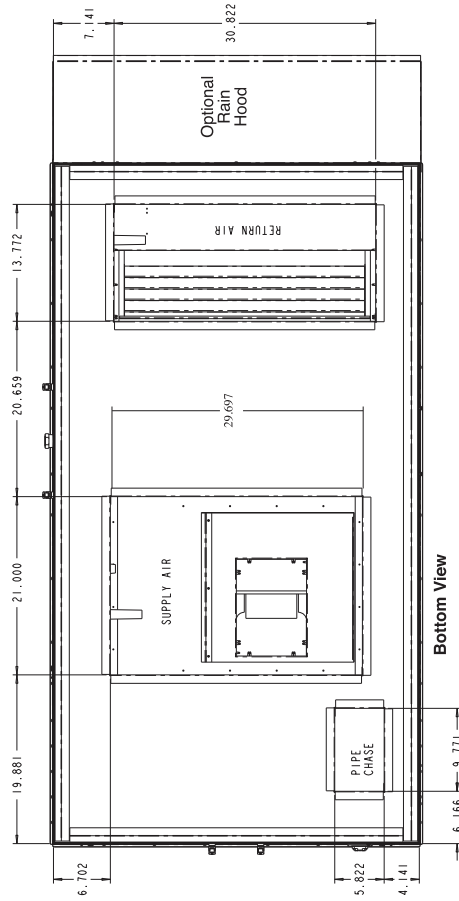
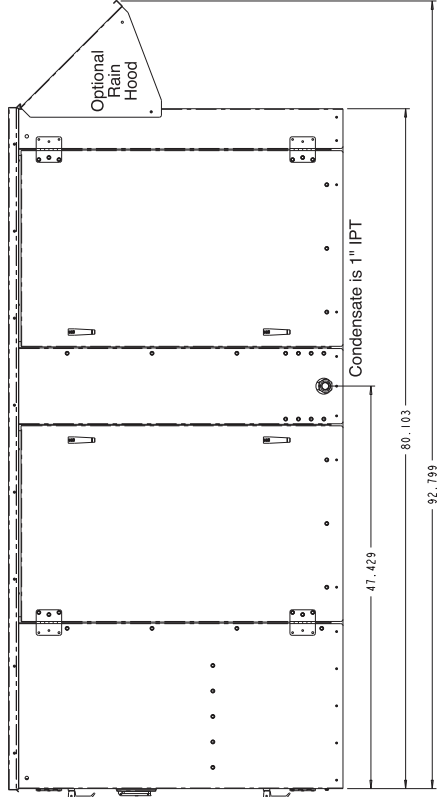
**IPT** — Iron (National) Pipe Thread

50RTP UNITS	DIMENSIONS (in.)		
	Outside Air Opening Size	Water In/Out (FPT)	Condensate Drain
03,04	12.57 x 30.00	3/4	1
05	12.57 x 30.00	1	1
06	12.57 x 30.00	1 1/4	1



**NOTES:**

1. All dimensions are in inches.
2. Carrier works continuously to improve its products. As a result, the design and specification of each product at the time of order may be changed without notice.
3. Assembly tolerances  $\pm 1/8$  inch.

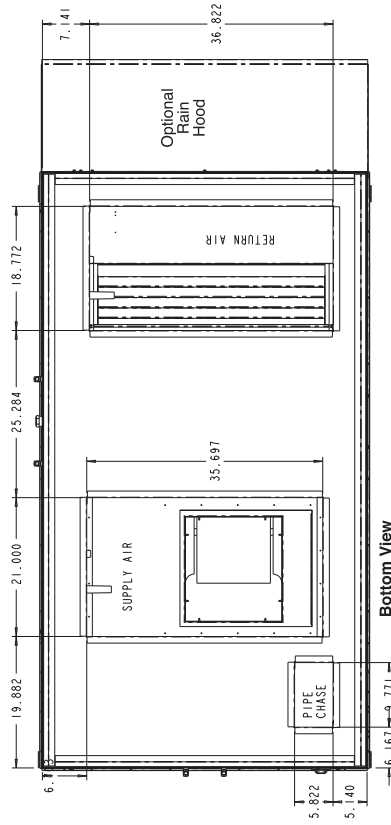
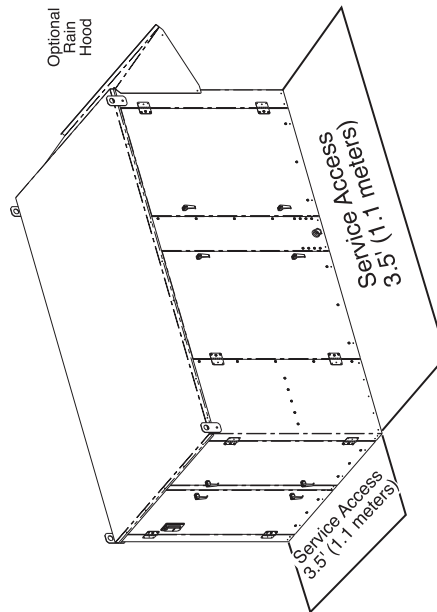
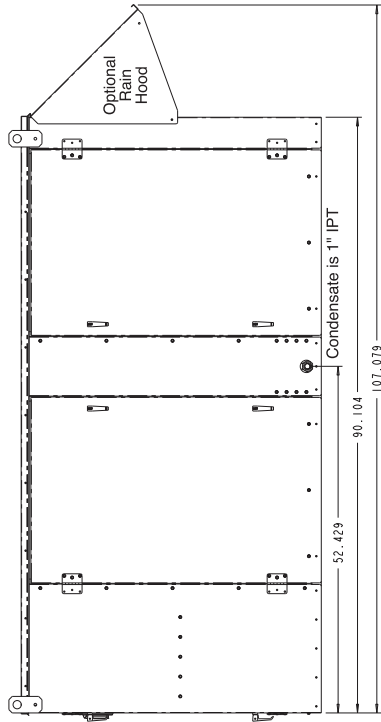
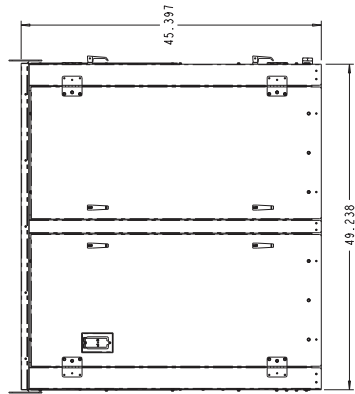


**Fig. 1 — 50RTP03-06 Unit Dimensions**

50RTP UNITS	DIMENSIONS (in.)		
	Outside Air Opening Size	Water In/Out (FPT)	Condensate Drain
08	18.95 x 36.00	1 1/4	1
10,12	18.95 x 36.00	1 1/2	1

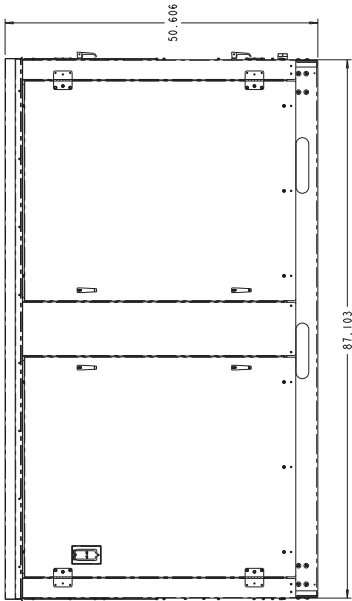
**NOTES:**

1. All dimensions are in inches.
2. Carrier works continuously to improve its products. As a result, the design and specification of each product at the time of order may be changed without notice.
3. Assembly tolerances  $\pm 1/8$  inch.



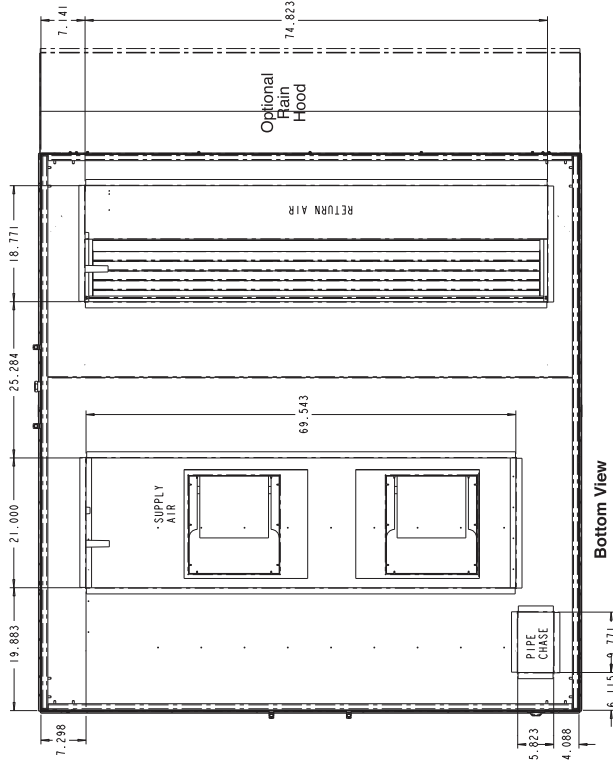
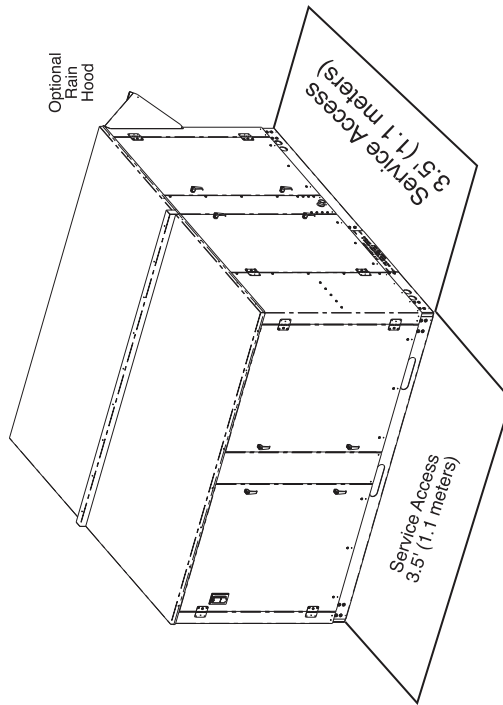
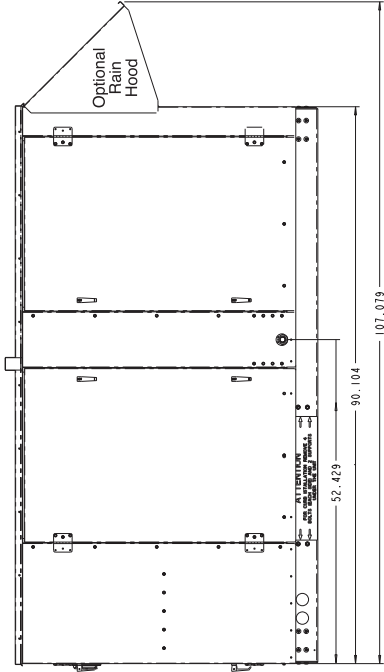
**Fig. 2 — 50RTP08-12 Unit Dimensions**

50RTP UNITS	DIMENSIONS (in.)		
	Outside Air Opening Size	Water In/Out (FPT)	Condensate Drain
14,20	18.95 x 74.00	2	1



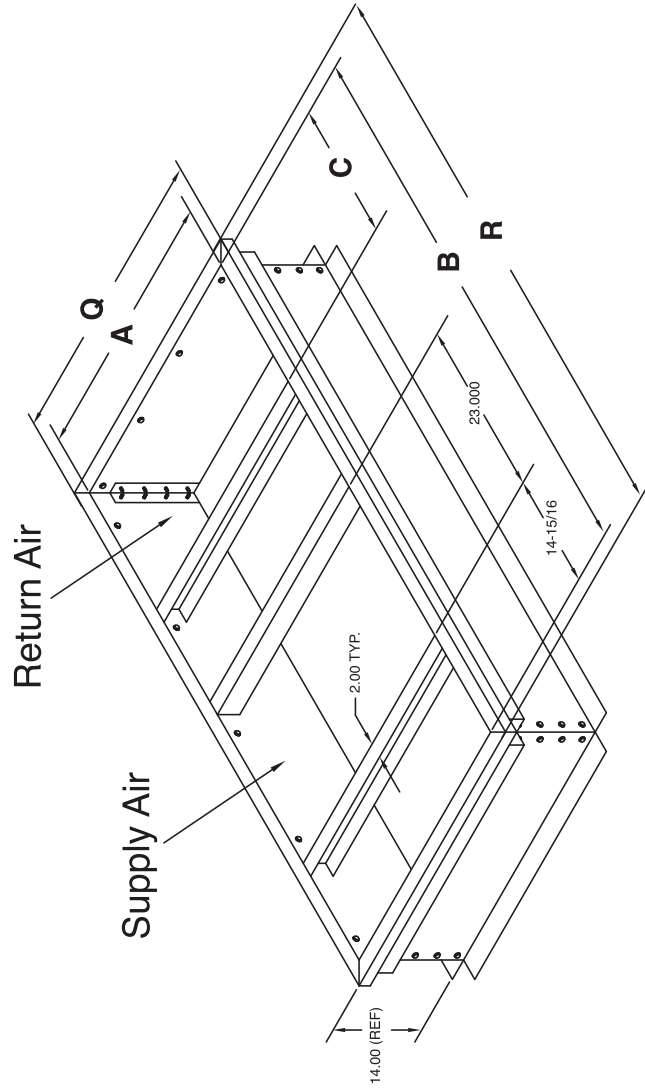
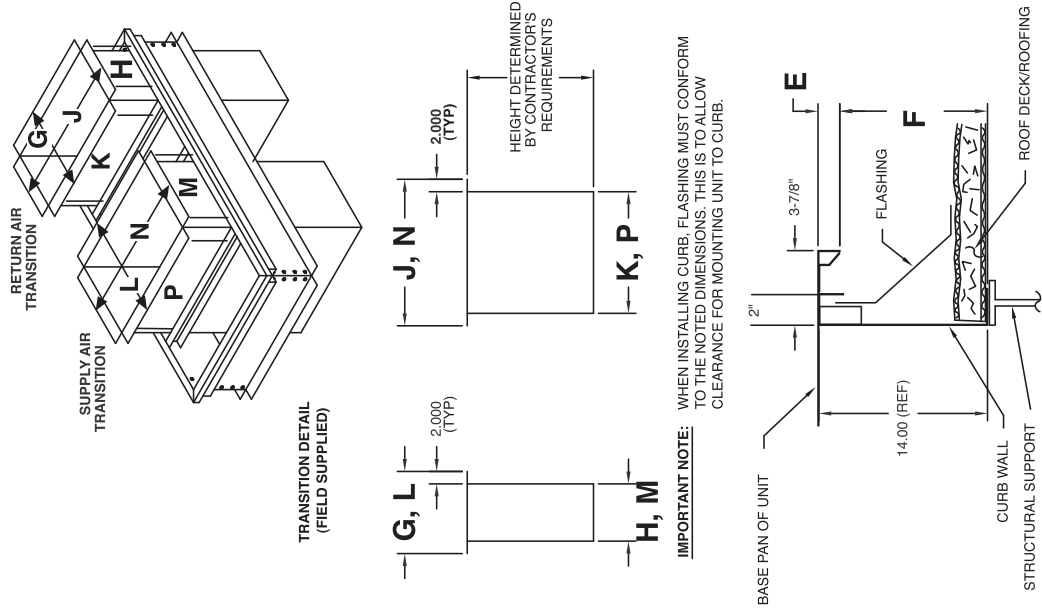
**NOTES:**

1. All dimensions are in inches.
2. Carrier works continuously to improve its products. As a result, the design and specification of each product at the time of order may be changed without notice.
3. Assembly tolerances  $\pm 1/8$  inch.



**Fig. 3 — 50RTP14,20 Unit Dimensions**

ROOF CURB	DIMENSIONS (in.)														
	A	B	C	E	F	Return Air Transition			Supply Air Transition			Exterior Dimensions			
	G	H	J	K	L	M	N	P	Q	R					
50RTPACURBAAAA	35.250	72.25	18.00	1.50	12.50	22.00	16.00	39.250	33.250	27.00	21.00	39.250	33.250	39.250	76.25
50RTPACURBBAAA	41.250	82.25	21.00	1.50	12.50	25.00	19.00	45.250	39.250	27.00	21.00	45.250	39.250	45.250	86.25
50RTPACURBCAAA	78.875	82.25	21.00	5.00	9.00	25.00	19.00	82.875	76.875	27.00	21.00	82.875	76.875	82.875	86.25

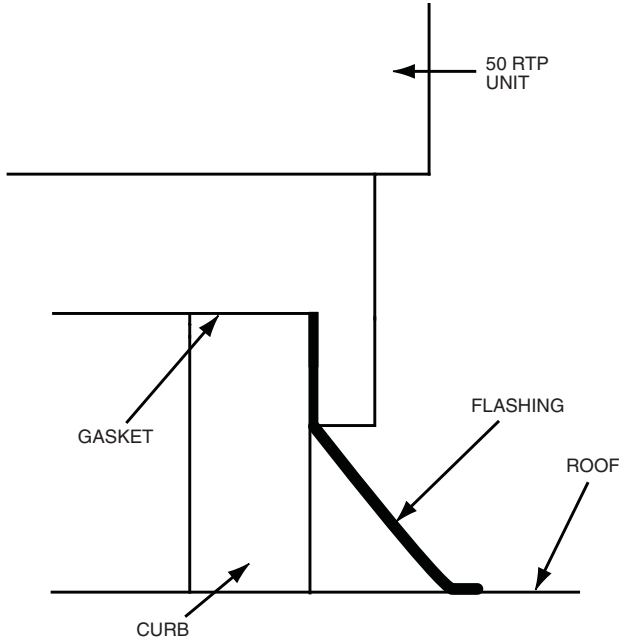


**IMPORTANT NOTE:** WHEN INSTALLING CURB, FLASHING MUST CONFORM TO THE NOTED DIMENSIONS. THIS IS TO ALLOW CLEARANCE FOR MOUNTING UNIT TO CURB.

**Fig. 4 — 50RTP Roof Curb Dimensions**

**Step 4 — Mount the Unit** — For proper operation, units must be mounted on a roof curb as shown in Fig. 5. Roof curb dimensional data is shown in Fig. 4. Follow these guidelines when installing the roof curb:

1. Set unit on curb.
2. Align unit so that its return and supply air direction match the return and supply air opening in the roof curb frame.
3. Run both the return and supply loop piping, as well as the electrical supply line, through the pipe chase provided in the curb.



**Fig. 5 — 50RTP Curb Installation**

**Step 5 — Install Condensate Drain**

1. Install a condensate trap at each unit with the top of the trap positioned below the unit condensate drain connection.
2. Design the length of the trap (water seal) based on the amount of positive or negative pressure on the drain pan. As a rule, 1 in. of trap is required for each inch of negative pressure on the unit.

Note that condensate is allowed to drain onto the roof.

**Step 6 — Make Piping Connections** — Depending on the application, there are 3 types of WSHP piping systems to choose from: water loop, ground-water and ground loop. Refer to Piping Section of Carrier System Design Manual for additional information.

All WSHP units use low temperature soldered female pipe thread fittings for water connections to prevent annealing and out-of-round leak problems which are typically associated with high temperature brazed connections. Refer to Table 1 for connection sizes. When making piping connections, consider the following:

- Use a backup wrench when making screw connections to unit to prevent internal damage to piping.
- Insulation may be required on piping to avoid condensation in the case where fluid in loop piping operates at temperatures below dew point of adjacent air.
- Piping systems that contain steel pipes or fittings may be subject to galvanic corrosion. Dielectric fittings may be used to isolate the steel parts of the system to avoid galvanic corrosion.

**WATER LOOP APPLICATIONS** — Water loop applications usually include a number of units plumbed to a common piping system. Maintenance to any of these units can introduce air into the piping system. Therefore, air elimination equipment comprises a major portion of the mechanical room plumbing.

The flow rate is usually set between 2.25 and 3 gpm per ton of cooling capacity. For proper maintenance and servicing, pressure-temperature (P/T) ports are necessary for temperature and flow verification.

In addition to complying with any applicable codes, consider the following for system piping:

- Piping systems utilizing water temperatures below 50 F require 1/2-in. closed cell insulation on all piping surfaces to eliminate condensation.
- All plastic to metal threaded fittings should be avoided due to the potential to leak. Use a flange fitted substitute.
- Teflon tape thread sealant is recommended to minimize internal fouling of the heat exchanger.
- Use backup wrench. Do not overtighten connections.
- Route piping to avoid service access areas to unit.
- The piping system should be flushed prior to operation to remove dirt and foreign materials from the system.

**GROUND-WATER APPLICATIONS** — In addition to complying with any applicable codes, consider the following for system piping:

- Install shut-off valves for servicing.
- Install pressure-temperature plugs to measure flow and temperature.
- Boiler drains and other valves should be connected using a “T” connector to allow acid flushing for the heat exchanger.
- Do not overtighten connections.
- Route piping to avoid service access areas to unit.
- Use PVC SCH80 or copper piping material.

NOTE: PVC SCH40 should *not* be used due to system high pressure and temperature extremes.

Water Supply and Quantity — Check water supply. Water supply should be plentiful and of good quality. See Table 2 for water quality guidelines.

**IMPORTANT:** Failure to comply with the above required water quality and quantity limitations and the closed-system application design requirements may cause damage to the tube-in-tube heat exchanger that is not the responsibility of the manufacturer.

In all applications, the quality of the water circulated through the heat exchanger must fall within the ranges listed in the Water Quality Guidelines table. Consult a local water treatment firm, independent testing facility, or local water authority for specific recommendations to maintain water quality within the published limits.

**GROUND-LOOP APPLICATIONS** — Temperatures between 25 to 110 F and a cooling capacity of 2.25 to 3 gpm of flow per ton is recommended. In addition to complying with any applicable codes, consider the following for system piping:

- Piping materials should be limited to only polyethylene fusion in the buried sections of the loop.
- Galvanized or steel fittings should not be used at any time due to corrosion.
- All plastic to metal threaded fittings should be avoided due to the potential to leak. Use a flange fitted substitute.
- Do not overtighten connections.
- Route piping to avoid service access areas to unit.
- Pressure-temperature (P/T) plugs should be used to measure flow of pressure drop.



**Table 2 — Water Quality Guidelines**

CONDITION	HX MATERIAL*	CLOSED RECIRCULATING†	OPEN LOOP AND RECIRCULATING WELL**
<b>Scaling Potential — Primary Measurement</b>			
Above the given limits, scaling is likely to occur. Scaling indexes should be calculated using the limits below.			
pH/Calcium Hardness Method	All	N/A	pH < 7.5 and Ca Hardness, <100 ppm
<b>Index Limits for Probable Scaling Situations (Operation outside these limits is not recommended.)</b>			
Scaling indexes should be calculated at 150 F for direct use and HWG applications, and at 90 F for indirect HX use. A monitoring plan should be implemented.			
Ryznar Stability Index	All	N/A	6.0 - 7.5 If >7.5 minimize steel pipe use.
Langelier Saturation Index	All	N/A	-0.5 to +0.5 If <-0.5 minimize steel pipe use. Based upon 150 F HWG and direct well, 85 F indirect well HX.
<b>Iron Fouling</b>			
Iron Fe <sup>2+</sup> (Ferrous) (Bacterial Iron Potential)	All	N/A	<0.2 ppm (Ferrous) If Fe <sup>2+</sup> (ferrous) >0.2 ppm with pH 6 - 8, O <sub>2</sub> <5 ppm check for iron bacteria.
Iron Fouling	All	N/A	<0.5 ppm of Oxygen Above this level deposition will occur.
<b>Corrosion Prevention††</b>			
pH	All	6 - 8.5 Monitor/treat as needed.	6 - 8.5 Minimize steel pipe below 7 and no open tanks with pH <8.
Hydrogen Sulfide (H <sub>2</sub> S)	All	N/A	<0.5 ppm At H <sub>2</sub> S>0.2 ppm, avoid use of copper and cupronickel piping or HXs. Rotten egg smell appears at 0.5 ppm level. Copper alloy (bronze or brass) cast components are okay to <0.5 ppm.
Ammonia Ion as Hydroxide, Chloride, Nitrate and Sulfate Compounds	All	N/A	<0.5 ppm
Maximum Chloride Levels			Maximum allowable at maximum water temperature.
			50 F (10 C)      75 F (24 C)      100 F (38 C)
	Copper	N/A	<20 ppm
	CuproNickel	N/A	NR
	304 SS	N/A	NR
	316 SS	N/A	<250 ppm
	Titanium	N/A	<550 ppm
			>550 ppm
			<150 ppm
			<375 ppm
			>375 ppm
<b>Erosion and Clogging</b>			
Particulate Size and Erosion	All	<10 ppm of particles and a maximum velocity of 6 fps. Filtered for maximum 800 micron size.	<10 ppm (<1 ppm "sand free" for reinjection) of particles and a maximum velocity of 6 fps. Filtered for maximum 800 micron size. Any particulate that is not removed can potentially clog components.

**LEGEND**

- HWG — Hot Water Generator
- HX — Heat Exchanger
- N/A — Design Limits Not Applicable Considering Recirculating Potable Water
- NR — Application Not Recommended
- SS — Stainless Steel

\*Heat exchanger materials considered are copper, cupronickel, 304 SS (stainless steel), 316 SS, titanium.

†Closed recirculating system is identified by a closed pressurized piping system.

\*\*Recirculating open wells should observe the open recirculating design considerations.

††If the concentration of these corrosives exceeds the maximum allowable level, then the potential for serious corrosion problems exists.

Sulfides in the water quickly oxidize when exposed to air, requiring that no agitation occur as the sample is taken. Unless tested immediately at the site, the sample will require stabilization with a few drops of one Molar zinc acetate solution, allowing accurate sulfide determination up to 24 hours after sampling. A low pH and high alkalinity cause system problems, even when both values are within ranges shown. The term pH refers to the acidity, basicity, or neutrality of the water supply. Below 7.0, the water is considered to be acidic. Above 7.0, water is considered to be basic. Neutral water contains a pH of 7.0.

NOTE: To convert ppm to grains per gallon, divide by 17. Hardness in mg/l is equivalent to ppm.

**Step 7 — Connect Electrical Wiring**

**⚠ WARNING**

Electrical shock can cause personal injury and death. Shut off all power to this equipment during installation. There may be more than one disconnect switch. Tag all disconnect locations to alert others not to restore power until work is completed.

**⚠ CAUTION**

Use only copper conductors for field-installed electrical wiring. Unit terminals are not designed to accept other types of conductors.

All field installed wiring, including the electrical ground, MUST comply with the National Electrical Code (NEC) as well as applicable local codes. In addition, all field wiring must conform to the Class II temperature limitations described in the NEC.

Refer to unit wiring diagrams in Fig. 6-16 for a schematic of the field connections which must be made by the installing (or electrical) contractor.

Consult the unit wiring diagram located on the inside of the compressor access panel to ensure proper electrical hookup. The installing (or electrical) contractor must make the field connections when using field-supplied disconnect.

Operating voltage must be the same voltage and phase as shown in electrical data shown in Table 3.

Make all final electrical connections with a length of flexible conduit to minimize vibration and sound transmission to the building.

**SUPPLY VOLTAGE** — Operating voltage to unit must be within voltage range indicated on unit nameplate.

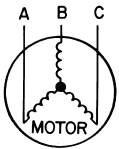
On 3-phase units, voltages under load between phases must be balanced within 2%. Use the following formula to determine the percentage voltage imbalance:

% Voltage Imbalance

$$= 100 \times \frac{\text{max voltage deviation from average voltage}}{\text{average voltage}}$$

Example: Supply voltage is 460-3-60.

AB = 452 volts  
 BC = 464 volts  
 AC = 455 volts



$$\begin{aligned} \text{Average Voltage} &= \frac{452 + 464 + 455}{3} \\ &= \frac{1371}{3} \\ &= 457 \end{aligned}$$

Determine maximum deviation from average voltage:

(AB) 457 - 452 = 5 v  
 (BC) 464 - 457 = 7 v  
 (AC) 457 - 455 = 2 v

Maximum deviation is 7 v.

Determine percent voltage imbalance.

$$\begin{aligned} \% \text{ Voltage Imbalance} &= 100 \times \frac{7}{457} \\ &= 1.53\% \end{aligned}$$

This amount of phase imbalance is satisfactory as it is below the maximum allowable 2%.

Operation on improper line voltage or excessive phase imbalance constitutes abuse and may cause damage to electrical components.

NOTE: If more than 2% voltage imbalance is present, contact local electric utility.

208-VOLT OPERATION — All 208-230 volt units are factory wired for 208 volts. The transformers may be switched to 230-volt operation (as illustrated on the wiring diagram) by switching the red (208 volt) wire with the orange (230 volt) wire at the L1 terminal.

BLOWER SELECTION — All water source heat pumps are factory set with the appropriate motor and sheave combination to achieve the desired airflow performance. Performance is selected by matching the desired performance with the appropriate region in Tables 4-12.

NOTE: Factory-installed sheaves are field adjustable. Refer to Tables 4-12 for adjustment points.

**Table 3 — Electrical Data**

50RTP UNIT SIZE	VOLTAGE CODE	VOLTAGE (V-Ph-Hz)	MIN/MAX VOLTAGE	BLOWER OPTION	COMPRESSOR			MOTOR			TOTAL UNIT FLA	MCA	MAX FUSE/HACR
					Qty	RLA	LRA	Qty	FLA	Hp			
03	5	208-3-60	197/254	A,B,C	1	10.4	73.0	1	4.0	1.0	14.4	17.0	25
	6	460-3-60	414/506	A,B,C	1	5.8	38.0	1	2.0	1.0	7.8	9.3	15
	1	575-3-60	518/633	A,B,C	1	3.8	36.5	1	1.4	1.0	5.2	6.2	15
04	5	208-3-60	197/254	A,B,C	1	13.7	83.1	1	4.0	1.0	17.7	21.1	35
				D,E	1	13.7	83.1	1	5.0	1.5	18.7	22.1	35
	6	460-3-60	414/506	A,B,C	1	6.2	41.0	1	2.0	1.0	8.2	9.8	15
				D,E	1	6.2	41.0	1	2.4	1.5	8.6	10.1	15
	1	575-3-60	518/633	A,B,C	1	4.8	33.0	1	1.4	1.0	6.2	7.4	15
				D,E	1	4.8	33.0	1	1.9	1.5	6.7	7.9	15
05	5	208-3-60	197/254	A,B,C	1	15.6	110.0	1	4.0	1.0	19.6	23.5	40
				D,E	1	15.6	110.0	1	5.0	1.5	20.6	24.5	40
	6	460-3-60	414/506	A,B,C	1	7.8	52.0	1	2.0	1.0	9.8	11.8	15
				D,E	1	7.8	52.0	1	2.4	1.5	10.2	12.2	15
	1	575-3-60	518/633	A,B,C	1	5.8	38.9	1	1.4	1.0	7.2	8.7	15
				D,E	1	5.8	38.9	1	1.9	1.5	7.7	9.2	15
06	5	208-3-60	197/254	A,B,C	1	20.5	155.0	1	5.0	1.5	25.5	30.6	50
				E	1	20.5	155.0	1	6.2	2.0	26.7	31.8	50
	6	460-3-60	414/506	A,B,C	1	9.6	75.0	1	2.4	1.5	12.0	14.4	20
				E	1	9.6	75.0	1	3.1	2.0	12.7	15.1	20
	1	575-3-60	518/633	A,B,C	1	7.6	54.0	1	1.9	1.5	9.5	11.4	15
				E	1	7.6	54.0	1	2.3	2.0	9.9	11.8	15
08	5	208-3-60	197/254	A,B,C	2	13.7	83.1	1	6.2	2.0	33.6	37.0	50
				E	2	13.7	83.1	1	9.2	3.0	36.6	40.0	50
	6	460-3-60	414/506	A,B,C	2	6.2	41.0	1	3.1	2.0	15.5	17.0	20
				E	2	6.2	41.0	1	4.3	3.0	16.7	18.3	20
	1	575-3-60	518/633	A,B,C	2	4.8	33.0	1	2.3	2.0	11.9	13.1	15
				E	2	4.8	33.0	1	3.4	3.0	13.0	14.2	15
10	5	208-3-60	197/254	A,B,C	2	15.6	110.0	1	9.2	3.0	40.4	44.3	60
				E	2	15.6	110.0	1	14.1	5.0	45.3	49.2	60
	6	460-3-60	414/506	A,B,C	2	7.8	52.0	1	4.3	3.0	19.9	21.9	25
				E	2	7.8	52.0	1	7.0	5.0	22.6	24.6	30
	1	575-3-60	518/633	A,B,C	2	5.8	38.9	1	3.4	3.0	15.0	16.5	20
				E	2	5.8	38.9	1	5.2	5.0	16.8	18.3	20
12	5	208-3-60	197/254	A,B,C	2	20.5	155.0	1	9.2	3.0	50.2	55.3	80
				D,E	2	20.5	155.0	1	14.1	5.0	55.1	60.2	80
	6	460-3-60	414/506	A,B,C	2	9.6	75.0	1	4.3	3.0	23.5	25.9	35
				D,E	2	9.6	75.0	1	7.0	5.0	26.2	28.6	35
	1	575-3-60	518/633	A,B,C	2	7.6	54.0	1	3.4	3.0	18.6	20.5	25
				D,E	2	7.6	54.0	1	5.2	5.0	20.4	22.3	25

**Table 3 — Electrical Data (cont)**

50RTP UNIT SIZE	VOLTAGE CODE	VOLTAGE (V-Ph-Hz)	MIN/MAX VOLTAGE	BLOWER OPTION	COMPRESSOR			MOTOR			TOTAL UNIT FLA	MCA	MAX FUSE/HACR
					Qty	RLA	LRA	Qty	FLA	Hp			
14	5	208-3-60	197/254	A,B,C	2	23.2	164.0	1	9.2	3.0	55.6	61.4	80
				D,E	2	23.2	164.0	1	14.1	5.0	60.5	66.3	80
	6	460-3-60	414/506	A,B,C	2	11.2	75.0	1	4.3	3.0	26.7	29.5	40
				D,E	2	11.2	75.0	1	7.0	5.0	29.4	32.2	40
	1	575-3-60	518/633	A,B,C	2	7.9	54.0	1	3.4	3.0	19.2	21.2	30
				D,E	2	7.9	54.0	1	5.2	5.0	21.0	23.0	30
20	5	208-3-60	197/254	A,B,C	2	30.1	225.0	1	14.1	5.0	74.3	81.8	110
				D,E	2	30.1	225.0	1	21.7	7.5	81.9	89.4	110
	6	460-3-60	414/506	A,B,C	2	16.7	114.0	1	7.0	5.0	40.4	44.6	60
				D,E	2	16.7	114.0	1	10.0	7.5	43.4	47.6	60
	1	575-3-60	518/633	A,B,C	2	12.2	80.0	1	5.2	5.0	29.6	32.6	45
				D,E	2	12.2	80.0	1	7.7	7.5	32.1	35.1	45

**LEGEND**

- FLA** — Full Load Amps
- HACR** — Heating, Air Conditioning, and Refrigeration
- LRA** — Locked Rotor Amps
- MCA** — Minimum Circuit Amps
- RLA** — Rated Load Amps

**Table 4 — 50RTP03 Blower Performance Data**

AIRFLOW (cfm)	ESP	AIRFLOW (cfm) AT EXTERNAL STATIC PRESSURE (in. wg)															
		0.0	0.1	0.2	0.3	0.4	0.5	0.6	0.7	0.8	0.9	1.0	1.1	1.2	1.3	1.4	1.5
900	bhp	0.10	0.13	0.16	0.17	0.19	0.22	0.24	0.26	0.28	0.30	0.33	0.35	0.37	0.40	0.44	0.47
	Sheave/Motor	B	B	B	A	A	A	A	A	A	A	C	C	C	C	C	C
	rpm	552	615	665	715	765	820	875	925	965	1010	1055	1100	1140	1180	1220	1260
	Turns Open	4.5	3.5	3.0	4.5	4.0	3.5	2.5	2.0	1.5	1.0	3.0	2.5	2.0	2.0	1.5	1.0
1000	bhp	0.16	0.17	0.19	0.21	0.23	0.25	0.28	0.30	0.33	0.36	0.40	0.43	0.46	0.49	0.52	0.55
	Sheave/Motor	B	B	A	A	A	A	A	A	A	C	C	C	C	C	C	
	rpm	615	655	695	740	790	845	900	940	985	1030	1070	1115	1150	1190	1230	1265
	Turns Open	3.5	3.0	5.0	4.0	3.5	3.0	2.0	1.5	1.0	0.5	3.0	2.5	2.0	1.5	1.5	1.0
1100	bhp	0.22	0.23	0.25	0.29	0.32	0.34	0.35	0.36	0.38	0.41	0.44	0.48	0.50	0.53	0.56	0.59
	Sheave/Motor	B	A	A	A	A	A	A	A	A	C	C	C	C	C	C	
	rpm	685	725	765	810	855	895	940	985	1025	1065	1105	1145	1180	1215	1250	1285
	Turns Open	2.5	5.0	4.0	3.5	2.5	2.5	1.5	1.0	0.5	3.0	2.5	2.0	1.5	1.5	1.0	0.5
1200	bhp	0.26	0.27	0.30	0.33	0.36	0.39	0.42	0.44	0.48	0.51	0.54	0.57	0.60	0.62	0.65	0.69
	Sheave/Motor	A	A	A	A	A	A	A	A	C	C	C	C	C	C	C	
	rpm	710	740	785	830	880	920	965	1005	1045	1085	1125	1160	1195	1230	1265	1300
	Turns Open	5.0	4.5	3.5	3.0	2.5	2.0	1.0	0.5	3.5	3.0	2.5	2.0	1.5	1.0	1.0	0.5
1300	bhp	0.30	0.33	0.36	0.40	0.42	0.44	0.46	0.50	0.55	0.61	0.65	0.68	0.71	0.74	0.76	0.79
	Sheave/Motor	A	A	A	A	A	A	A	A	C	C	C	C	C	C	C	
	rpm	750	790	830	870	910	950	990	1030	1065	1105	1140	1175	1210	1245	1280	1315
	Turns Open	4.0	3.5	3.0	2.5	2.0	1.5	1.0	0.5	3.0	2.5	2.0	1.5	1.5	1.0	0.5	0.0
1400	bhp	0.40	0.42	0.44	0.47	0.50	0.53	0.56	0.60	0.64	0.67	0.70	0.72	0.75	0.79	0.84	0.88
	Sheave/Motor	A	A	A	A	A	A	A	C	C	C	C	C	C	C	C	
	rpm	820	850	875	915	950	990	1025	1065	1100	1135	1170	1205	1235	1270	1305	1335
	Turns Open	3.0	2.5	2.5	2.0	1.5	1.0	0.5	3.0	2.5	2.0	2.0	1.5	1.0	0.5	0.5	0.0
1500	bhp	0.45	0.47	0.50	0.52	0.55	0.59	0.64	0.69	0.74	0.77	0.80	0.83	0.86	0.90	0.93	—
	Sheave/Motor	A	A	A	A	A	A	C	C	C	C	C	C	C	C	C	
	rpm	860	885	920	955	985	1020	1055	1090	1125	1160	1190	1225	1255	1290	1320	—
	Turns Open	2.5	2.0	2.0	1.5	1.0	0.5	3.0	2.5	2.0	2.0	1.5	1.0	1.0	0.5	0.0	—

**LEGEND**

- bhp** — Brake Horsepower
- ESP** — External Static Pressure

**NOTES:**

1. A = Standard RPM/Standard Motor, B = Low RPM/Standard Motor, C = High RPM/Standard Motor

2. Unit shipped with standard drive package with drive sheave 2.5 turns open unless otherwise requested. Field adjustment may be required for specified CFM.
3. ISO/AHRI rating point with standard drive package and drive sheave open 3.0 turns at .30 ESP.
4. Performance data does not include drive losses and is based on sea level conditions.
5. All airflow is rated at lowest voltage if unit is dual rated, i.e., rated at 208 volts for 208-230 volt units.

**Table 5 — 50RTP04 Blower Performance Data**

AIRFLOW (cfm)	ESP	AIRFLOW (cfm) AT EXTERNAL STATIC PRESSURE (in. wg)															
		0.0	0.1	0.2	0.3	0.4	0.5	0.6	0.7	0.8	0.9	1.0	1.1	1.2	1.3	1.4	1.5
1200	bhp	0.27	0.31	0.34	0.37	0.40	0.42	0.45	0.48	0.52	0.55	0.58	0.60	0.63	0.66	0.70	0.73
	Sheave/Motor	B	B	A	A	A	A	A	A	A	A	A	C	C	C	C	C
	rpm	750	800	845	890	935	975	1015	1055	1095	1135	1170	1205	1240	1275	1310	1345
	Turns Open	5.0	4.0	5.0	4.0	3.5	3.0	2.5	1.5	1.0	0.5	0.0	3.0	2.5	2.0	1.5	1.5
1300	bhp	0.35	0.38	0.41	0.43	0.45	0.47	0.53	0.59	0.64	0.67	0.70	0.72	0.75	0.78	0.80	0.83
	Sheave/Motor	B	A	A	A	A	A	A	A	A	A	C	C	C	C	C	C
	rpm	810	850	890	930	970	1010	1050	1090	1125	1160	1195	1230	1265	1300	1330	1365
	Turns Open	4.0	4.5	4.0	3.5	3.0	2.5	2.0	1.0	0.5	0.0	3.0	3.0	2.5	2.0	1.5	1.0
1400	bhp	0.43	0.46	0.49	0.52	0.55	0.58	0.62	0.66	0.68	0.71	0.74	0.77	0.82	0.86	0.91	0.96
	Sheave/Motor	A	A	A	A	A	A	A	A	A	C	C	C	C	C	C	C
	rpm	865	900	935	970	1010	1045	1085	1120	1155	1190	1220	1255	1290	1320	1355	1390
	Turns Open	4.5	4.0	3.5	3.0	2.5	2.0	1.5	0.5	0.0	3.5	3.0	2.5	2.0	1.5	1.0	1.0
1500	bhp	0.49	0.52	0.54	0.57	0.62	0.68	0.73	0.76	0.79	0.82	0.85	0.89	0.92	0.96	1.00	1.05
	Sheave/Motor	A	A	A	A	A	A	A	A	C	C	C	C	C	C	E	E
	rpm	910	945	975	1010	1045	1080	1115	1150	1180	1215	1250	1280	1310	1345	1375	1405
	Turns Open	3.5	3.5	3.0	2.5	2.0	1.5	1.0	0.0	3.5	3.0	2.5	2.0	2.0	1.5	1.0	0.5
1600	bhp	0.62	0.65	0.67	0.70	0.72	0.75	0.78	0.82	0.86	0.89	0.94	1.00	1.04	1.08	1.13	1.18
	Sheave/Motor	A	A	A	A	A	A	A	C	C	C	C	E	E	E	E	E
	rpm	960	985	1015	1050	1080	1115	1145	1175	1210	1240	1275	1305	1335	1365	1395	1425
	Turns Open	3.0	2.5	2.5	2.0	2.0	1.5	0.5	3.5	3.0	2.5	2.5	2.0	1.5	1.0	0.5	0.5
1700	bhp	0.74	0.77	0.80	0.83	0.85	0.88	0.90	0.93	0.95	1.00	1.06	1.11	1.17	1.22	1.27	1.31
	Sheave/Motor	A	A	A	A	A	A	C	C	C	E	E	E	E	E	E	E
	rpm	1000	1030	1060	1090	1115	1150	1180	1210	1240	1270	1300	1330	1360	1390	1420	1445
	Turns Open	2.5	2.0	1.5	1.5	1.0	1.0	3.5	3.0	3.0	2.5	2.0	1.5	1.0	1.0	0.5	0.0
1800	bhp	0.83	0.87	0.90	0.94	0.98	1.02	1.06	1.09	1.14	1.18	1.23	1.28	1.32	1.36	—	—
	Sheave/Motor	A	A	A	A	A	E	E	E	E	E	E	E	E	E	—	—
	rpm	1050	1075	1100	1125	1155	1185	1215	1245	1275	1300	1330	1360	1385	1415	—	—
	Turns Open	2.0	1.5	1.0	0.5	0.5	3.5	3.0	2.5	2.5	2.0	1.5	1.0	1.0	0.5	—	—
1900	bhp	0.97	1.00	1.03	1.08	1.12	1.16	1.20	1.25	1.29	1.34	1.38	1.42	—	—	—	—
	Sheave/Motor	A	D	D	E	E	E	E	E	E	E	E	E	—	—	—	—
	rpm	1100	1120	1145	1175	1200	1225	1250	1280	1305	1335	1360	1385	—	—	—	—
	Turns Open	1.0	1.0	0.5	3.5	3.0	3.0	2.5	2.0	2.0	1.5	1.0	1.0	—	—	—	—
2000	bhp	1.13	1.17	1.20	1.24	1.28	1.32	1.36	1.40	1.44	—	—	—	—	—	—	—
	Sheave/Motor	D	D	E	E	E	E	E	E	E	—	—	—	—	—	—	—
	rpm	1145	1170	1190	1215	1235	1260	1290	1315	1340	—	—	—	—	—	—	—
	Turns Open	0.5	0.5	3.0	3.0	2.5	2.5	2.0	1.5	1.5	—	—	—	—	—	—	—

**LEGEND**

**bhp** — Brake Horsepower  
**ESP** — External Static Pressure

**NOTES:**

1. A = Standard RPM/Standard Motor, B = Low RPM/Standard Motor, C = High RPM/Standard Motor, D = Standard RPM/Large Motor, E = High RPM/Large Motor

2. Unit shipped with standard drive package with drive sheave 2.5 turns open unless otherwise requested. Field adjustment may be required for specified CFM.
3. ISO/AHRI rating point with standard drive package and drive sheave open 3.0 turns at .30 ESP.
4. Performance data does not include drive losses and is based on sea level conditions.
5. All airflow is rated at lowest voltage if unit is dual rated, i.e., rated at 208 volts for 208-230 volt units.

**Table 6 — 50RTP05 Blower Performance Data**

AIRFLOW (cfm)	ESP	AIRFLOW (cfm) AT EXTERNAL STATIC PRESSURE (in. wg)															
		0.0	0.1	0.2	0.3	0.4	0.5	0.6	0.7	0.8	0.9	1.0	1.1	1.2	1.3	1.4	1.5
1500	bhp	0.17	0.22	0.26	0.29	0.31	0.34	0.37	0.40	0.44	0.47	0.5	0.53	0.56	0.60	0.63	0.65
	Sheave/Motor	B	B	B	B	A	A	A	A	A	A	A	A	A	C	C	C
	rpm	516	573	625	670	710	755	785	820	850	880	900	925	945	970	990	1010
	Turns Open	5.0	4.5	3.5	2.5	4.5	4.0	3.5	3.0	2.0	1.5	1.5	1.0	0.5	3.0	2.5	2.5
1600	bhp	0.20	0.24	0.28	0.32	0.35	0.38	0.41	0.45	0.48	0.52	0.55	0.58	0.62	0.65	0.68	0.70
	Sheave/Motor	B	B	B	A	A	A	A	A	A	A	A	A	C	C	C	C
	rpm	526	583	635	680	725	765	795	830	860	890	915	940	965	990	1010	1030
	Turns Open	5.0	4.5	3.5	5.0	4.5	3.5	3.0	2.5	2.0	1.5	1.0	0.5	3.0	2.5	2.5	2.0
1700	bhp	0.23	0.26	0.30	0.34	0.38	0.42	0.45	0.49	0.53	0.56	0.60	0.64	0.67	0.71	0.73	0.75
	Sheave/Motor	B	B	B	A	A	A	A	A	A	A	A	A	C	C	C	C
	rpm	536	589	640	685	730	770	805	840	875	900	930	955	980	1005	1025	1045
	Turns Open	4.5	4.0	3.0	5.0	4.0	3.5	3.0	2.5	2.0	1.5	1.0	0.5	3.0	2.5	2.0	2.0
1800	bhp	0.25	0.29	0.33	0.37	0.41	0.46	0.50	0.54	0.58	0.62	0.65	0.68	0.72	0.76	0.78	0.81
	Sheave/Motor	B	B	B	A	A	A	A	A	A	A	A	C	C	C	C	C
	rpm	547	599	650	695	740	780	815	855	885	915	940	965	995	1020	1040	1060
	Turns Open	4.5	4.0	3.0	4.5	4.0	3.5	2.5	2.0	1.5	1.0	0.5	3.0	2.5	2.0	2.0	1.5
1900	bhp	0.29	0.32	0.37	0.41	0.46	0.50	0.55	0.59	0.62	0.66	0.70	0.73	0.77	0.81	0.85	0.88
	Sheave/Motor	B	B	B	A	A	A	A	A	A	A	A	C	C	C	C	C
	rpm	568	620	665	710	755	790	830	865	895	925	955	985	1015	1035	1060	1080
	Turns Open	4.5	3.5	3.0	4.5	3.5	3.0	2.5	2.0	1.5	1.0	0.5	2.5	2.0	2.0	1.5	1.0
2000	bhp	0.33	0.36	0.42	0.47	0.52	0.57	0.61	0.66	0.69	0.73	0.77	0.81	0.85	0.89	0.92	0.96
	Sheave/Motor	B	B	A	A	A	A	A	A	A	C	C	C	C	C	C	C
	rpm	589	635	680	725	765	805	845	880	910	940	975	1005	1030	1055	1075	1100
	Turns Open	4.0	3.5	5.0	4.0	3.5	3.0	2.0	1.5	1.0	0.5	3.0	2.5	2.0	1.5	1.5	1.0
2100	bhp	0.41	0.45	0.49	0.52	0.57	0.63	0.68	0.72	0.76	0.80	0.84	0.88	0.92	0.96	1.00	1.04
	Sheave/Motor	B	B	A	A	A	A	A	A	A	A	C	C	C	C	E	E
	rpm	615	660	700	740	780	820	860	895	925	960	990	1020	1045	1070	1095	1120
	Turns Open	3.5	3.0	4.5	4.0	3.0	2.5	2.0	1.5	1.0	0.5	2.5	2.0	2.0	1.5	1.0	0.5
2200	bhp	0.44	0.49	0.54	0.58	0.64	0.69	0.74	0.78	0.83	0.87	0.91	0.96	1.00	1.04	1.08	1.12
	Sheave/Motor	B	A	A	A	A	A	A	A	A	C	C	C	E	E	E	E
	rpm	640	680	720	760	800	840	880	910	945	975	1005	1035	1060	1085	1115	1135
	Turns Open	3.0	5.0	4.5	3.5	3.0	2.5	1.5	1.0	0.5	3.0	2.5	2.0	1.5	1.5	1.0	0.5
2300	bhp	0.52	0.56	0.60	0.65	0.70	0.75	0.80	0.85	0.89	0.94	1.00	1.05	1.11	1.16	1.22	1.25
	Sheave/Motor	B	A	A	A	A	A	A	A	C	C	E	E	E	E	E	E
	rpm	665	705	745	785	825	860	895	930	960	995	1025	1050	1080	1105	1135	1155
	Turns Open	3.0	4.5	4.0	3.5	2.5	2.0	1.5	0.5	3.0	2.5	2.0	2.0	1.5	1.0	0.5	0.5
2400	bhp	0.57	0.62	0.67	0.73	0.79	0.84	0.89	1.00	1.00	1.03	1.08	1.14	1.20	1.26	1.30	1.35
	Sheave/Motor	A	A	A	A	A	A	A	D	D	E	E	E	E	E	E	E
	rpm	695	735	775	810	850	885	920	950	980	1015	1040	1070	1100	1130	1150	1175
	Turns Open	5.0	4.0	3.5	3.0	2.0	1.5	1.0	0.5	0.0	2.0	2.0	1.5	1.0	0.5	0.5	0.0
2500	bhp	0.64	0.69	0.75	0.81	0.87	0.92	1.00	1.01	1.05	1.11	1.17	1.23	1.29	1.34	1.39	1.43
	Sheave/Motor	A	A	A	A	A	A	D	D	E	E	E	E	E	E	E	E
	rpm	725	765	800	835	870	905	940	970	1000	1030	1060	1090	1120	1145	1170	1190
	Turns Open	4.5	3.5	3.0	2.5	2.0	1.5	0.5	0.0	2.5	2.0	1.5	1.0	0.5	0.5	0.0	0.0

**LEGEND**

**bhp** — Brake Horsepower  
**ESP** — External Static Pressure

**NOTES:**

1. A = Standard RPM/Standard Motor, B = Low RPM/Standard Motor, C = High RPM/Standard Motor, D = Standard RPM/ Large Motor, E = High RPM/Large Motor

2. Unit shipped with standard drive package with drive sheave 2.5 turns open unless otherwise requested. Field adjustment may be required for specified CFM.
3. ISO/AHRI rating point with standard drive package and drive sheave open 3.0 turns at .30 ESP.
4. Performance data does not include drive losses and is based on sea level conditions.
5. All airflow is rated at lowest voltage if unit is dual rated, i.e., rated at 208 volts for 208-230 volt units.

**Table 7 — 50RTP06 Blower Performance Data**

AIRFLOW (cfm)	ESP	AIRFLOW (cfm) AT EXTERNAL STATIC PRESSURE (in. wg)															
		0.0	0.1	0.2	0.3	0.4	0.5	0.6	0.7	0.8	0.9	1.0	1.1	1.2	1.3	1.4	1.5
1800	bhp	0.27	0.31	0.35	0.39	0.43	0.47	0.51	0.55	0.59	0.62	0.66	0.70	0.74	0.76	0.79	0.83
	Sheave/Motor	B	B	B	B	A	A	A	A	A	A	A	A	A	C	C	C
	rpm	568	620	665	710	755	790	830	865	895	920	950	975	1005	1025	1045	1070
	Turns Open	5.0	3.5	2.5	1.5	5.0	4.0	3.5	3.0	2.5	2.0	1.0	0.5	0.0	4.0	4.0	3.5
1900	bhp	0.29	0.33	0.37	0.42	0.46	0.50	0.55	0.59	0.63	0.67	0.70	0.74	0.77	0.81	0.85	0.89
	Sheave/Motor	B	B	B	B	A	A	A	A	A	A	A	A	C	C	C	C
	rpm	573	625	670	715	755	795	830	870	900	930	960	990	1015	1040	1060	1085
	Turns Open	4.5	3.5	2.5	1.5	5.0	4.0	3.5	3.0	2.0	1.5	1.0	0.5	4.5	4.0	3.5	3.5
2000	bhp	0.32	0.36	0.41	0.46	0.51	0.56	0.60	0.65	0.69	0.72	0.76	0.80	0.84	0.88	0.92	0.96
	Sheave/Motor	B	B	B	B	A	A	A	A	A	A	A	A	C	C	C	C
	rpm	583	630	675	720	760	800	835	875	905	935	970	1000	1025	1050	1075	1100
	Turns Open	4.5	3.0	2.0	1.0	4.5	3.5	3.0	2.5	2.0	1.5	0.5	0.0	4.0	3.5	3.5	3.0
2100	bhp	0.39	0.44	0.47	0.51	0.56	0.61	0.66	0.71	0.75	0.79	0.83	0.87	0.91	0.95	0.99	1.03
	Sheave/Motor	B	B	B	B	A	A	A	A	A	A	A	C	C	C	C	C
	rpm	599	645	685	725	770	805	845	885	915	950	980	1010	1035	1060	1085	1110
	Turns Open	4.0	3.0	2.0	1.0	4.5	3.5	3.0	2.5	1.5	1.0	0.5	4.5	4.0	3.5	3.0	3.0
2200	bhp	0.42	0.47	0.52	0.56	0.62	0.67	0.72	0.77	0.81	0.85	0.89	0.93	0.98	1.02	1.06	1.11
	Sheave/Motor	B	B	B	A	A	A	A	A	A	A	A	C	C	C	C	C
	rpm	620	665	705	745	785	825	865	900	930	960	995	1020	1050	1075	1100	1130
	Turns Open	3.5	2.5	1.5	5.0	4.0	3.5	2.5	2.0	1.5	1.0	0.0	4.0	3.5	3.5	3.0	2.5
2300	bhp	0.49	0.54	0.58	0.62	0.67	0.72	0.78	0.82	0.87	0.91	0.97	1.02	1.08	1.13	1.19	1.23
	Sheave/Motor	B	B	B	A	A	A	A	A	A	A	C	C	C	C	C	C
	rpm	640	685	725	765	800	840	880	910	945	975	1010	1035	1065	1090	1120	1145
	Turns Open	3.0	2.0	1.0	4.5	4.0	3.0	2.5	2.0	1.0	0.5	4.5	4.0	3.5	3.0	2.5	2.5
2400	bhp	0.54	0.58	0.62	0.68	0.74	0.79	0.85	0.90	0.94	0.99	1.04	1.10	1.15	1.21	1.27	1.31
	Sheave/Motor	B	B	A	A	A	A	A	A	A	A	C	C	C	C	C	C
	rpm	660	700	740	780	820	855	890	925	955	990	1020	1050	1075	1105	1135	1155
	Turns Open	2.5	1.5	5.0	4.5	3.5	3.0	2.0	1.5	1.0	0.5	4.0	3.5	3.5	3.0	2.5	2.0
2500	bhp	0.59	0.64	0.69	0.75	0.81	0.87	0.92	0.96	1.01	1.05	1.11	1.17	1.23	1.29	1.34	1.39
	Sheave/Motor	B	B	A	A	A	A	A	A	A	A	C	C	C	C	C	C
	rpm	680	725	765	800	835	870	905	935	970	1000	1030	1060	1090	1120	1145	1170
	Turns Open	2.0	1.0	4.5	4.0	3.5	3.0	2.0	1.5	0.5	0.0	4.0	3.5	3.0	C	2.0	2.0
2600	bhp	0.64	0.69	0.75	0.80	0.86	0.92	0.97	1.02	1.08	1.13	1.19	1.25	1.30	1.36	1.41	1.50
	Sheave/Motor	B	A	A	A	A	A	A	A	A	C	C	C	C	C	C	E
	rpm	700	740	780	815	850	885	920	950	985	1015	1045	1075	1100	1130	1155	1180
	Turns Open	1.5	5.0	4.5	3.5	3.0	2.5	2.0	1.0	0.5	4.5	3.5	3.0	3.0	2.5	2.0	1.5
2700	bhp	0.70	0.75	0.80	0.86	0.91	0.97	1.02	1.08	1.14	1.20	1.26	1.32	1.38	1.50	1.52	1.56
	Sheave/Motor	B	A	A	A	A	A	A	A	C	C	C	C	C	E	E	E
	rpm	725	760	795	830	865	900	930	960	995	1025	1055	1085	1115	1140	1165	1190
	Turns Open	1.0	4.5	4.0	3.5	3.0	2.0	1.5	1.0	4.5	4.0	3.5	3.0	2.5	2.0	2.0	1.5
2800	bhp	0.76	0.82	0.88	0.93	0.98	1.05	1.10	1.16	1.22	1.30	1.37	1.44	1.50	1.56	1.63	1.69
	Sheave/Motor	A	A	A	A	A	A	A	A	C	C	C	C	E	E	E	E
	rpm	745	780	815	850	880	915	945	980	1010	1040	1070	1100	1125	1150	1180	1205
	Turns Open	5.0	4.0	3.5	3.0	2.5	1.5	1.0	0.5	4.5	4.0	3.5	3.0	2.5	2.0	1.5	1.5
2900	bhp	0.82	0.88	0.93	0.98	1.05	1.11	1.17	1.23	1.30	1.37	1.44	1.51	1.59	1.65	1.71	1.77
	Sheave/Motor	A	A	A	A	A	A	A	C	C	C	C	E	E	E	E	E
	rpm	765	800	830	865	900	930	960	990	1020	1050	1080	1110	1140	1165	1190	1215
	Turns Open	4.5	4.0	3.5	2.5	2.0	1.5	0.5	4.5	4.0	3.5	3.0	2.5	2.5	2.0	1.5	1.0
3000	bhp	0.91	0.96	1.02	1.07	1.13	1.20	1.26	1.32	1.38	1.46	1.53	1.60	1.66	1.72	1.78	1.84
	Sheave/Motor	A	A	A	A	A	A	A	C	C	C	E	E	E	E	E	E
	rpm	785	820	855	885	915	950	980	1010	1035	1065	1095	1125	1150	1175	1200	1225
	Turns Open	4.0	3.5	3.0	2.5	2.0	1.0	0.5	4.0	4.0	3.5	3.0	2.5	2.0	1.5	1.5	1.0

**LEGEND**

**bhp** — Brake Horsepower  
**ESP** — External Static Pressure

**NOTES:**

1. A = Standard RPM/Standard Motor, B = Low RPM/Standard Motor, C = High RPM/Standard Motor, E = High RPM/Large Motor

2. Unit shipped with standard drive package with drive sheave 2.5 turns open unless otherwise requested. Field adjustment may be required for specified CFM.
3. ISO/AHRI rating point with standard drive package and drive sheave open 3.0 turns at .30 ESP.
4. Performance data does not include drive losses and is based on sea level conditions.
5. All airflow is rated at lowest voltage if unit is dual rated, i.e., rated at 208 volts for 208-230 volt units.

**Table 8 — 50RTP08 Blower Performance Data**

AIRFLOW (cfm)	ESP	AIRFLOW (cfm) AT EXTERNAL STATIC PRESSURE (in. wg)																				
		0.0	0.1	0.2	0.3	0.4	0.5	0.6	0.7	0.8	0.9	1.0	1.1	1.2	1.3	1.4	1.5	1.6	1.7	1.8	1.9	2.0
2400	bhp	0.36	0.39	0.42	0.46	0.52	0.6	0.67	0.7	0.74	0.77	0.82	0.88	0.95	1.01	1.07	1.13	1.18	1.22	1.27	1.32	1.37
	Sheave/Motor	B	B	B	B	A	A	A	A	A	A	A	A	A	C	C	C	C	C	C	C	C
	rpm	500	525	563	596	632	668	704	728	756	780	808	832	856	880	904	928	948	968	988	1008	1028
2500	Turns Open	6.0	5.0	4.0	3.0	6.0	5.0	4.5	4.0	3.5	2.5	2.0	1.5	1.0	6.0	5.5	5.0	4.5	4.0	4.0	3.5	3.5
	bhp	0.40	0.45	0.50	0.56	0.62	0.67	0.72	0.76	0.80	0.85	0.90	0.97	1.05	1.12	1.18	1.22	1.26	1.31	1.36	1.40	1.46
	Sheave/Motor	B	B	B	B	A	A	A	A	A	A	A	A	A	C	C	C	C	C	C	C	C
2600	rpm	504	538	575	612	648	680	712	740	764	792	816	840	868	892	916	936	956	976	1000	1016	1036
	Turns Open	5.5	4.5	3.5	3.0	5.5	5.0	4.5	4.0	3.5	3.0	2.5	2.0	1.5	1.0	5.5	5.0	4.5	4.0	4.0	3.5	3.5
	bhp	0.47	0.51	0.55	0.60	0.67	0.73	0.78	0.84	0.89	0.94	1.00	1.05	1.11	1.16	1.23	1.28	1.35	1.41	1.46	1.51	1.56
2700	Sheave/Motor	B	B	B	A	A	A	A	A	A	A	A	A	C	C	C	C	C	C	C	C	C
	rpm	521	554	592	624	660	692	720	748	776	800	828	852	876	900	924	944	968	988	1008	1028	1048
	Turns Open	5.5	4.5	3.5	6.0	5.5	4.5	4.0	3.5	2.5	2.0	1.5	1.0	6.0	5.5	5.0	4.5	4.0	4.0	3.5	3.5	3.0
2800	bhp	0.51	0.56	0.61	0.66	0.72	0.77	0.82	0.88	0.94	0.99	1.06	1.14	1.21	1.27	1.32	1.39	1.44	1.50	1.55	1.59	1.65
	Sheave/Motor	B	B	B	A	A	A	A	A	A	A	A	A	C	C	C	C	C	C	C	C	C
	rpm	538	571	608	640	672	704	732	760	788	812	836	864	888	912	932	956	976	1000	1020	1036	1056
2900	Turns Open	5.0	4.0	3.0	5.5	5.0	4.0	3.5	3.0	2.5	2.0	1.5	1.0	5.5	5.0	4.5	4.0	3.5	3.0	3.0	3.0	3.0
	bhp	0.57	0.62	0.67	0.72	0.77	0.83	0.90	0.96	1.03	1.08	1.15	1.20	1.25	1.33	1.40	1.48	1.56	1.62	1.67	1.71	1.75
	Sheave/Motor	B	B	B	A	A	A	A	A	A	A	A	C	C	C	C	C	C	C	C	C	C
3000	rpm	550	583	616	648	684	712	740	768	796	820	848	872	896	920	940	964	988	1008	1028	1044	1064
	Turns Open	4.5	3.5	2.5	5.5	5.0	4.0	3.5	3.0	2.5	2.0	1.5	6.0	5.5	5.0	4.5	4.0	4.0	3.5	3.0	3.0	2.5
	bhp	0.62	0.66	0.72	0.78	0.83	0.89	0.95	1.02	1.08	1.15	1.22	1.30	1.37	1.44	1.51	1.58	1.66	1.70	1.75	1.79	1.84
3100	Sheave/Motor	B	A	A	A	A	A	A	A	A	A	A	C	C	C	C	C	C	C	C	C	C
	rpm	567	600	632	664	696	724	752	780	808	832	856	884	908	932	952	976	1000	1016	1036	1056	1076
	Turns Open	4.0	3.0	5.5	5.0	4.5	3.5	3.0	2.5	2.0	1.5	1.0	5.5	5.0	4.5	4.5	4.0	3.5	3.5	3.0	3.0	2.5
3200	bhp	0.68	0.73	0.78	0.83	0.89	0.97	1.05	1.13	1.18	1.24	1.30	1.35	1.42	1.51	1.60	1.68	1.76	1.80	1.85	1.88	1.92
	Sheave/Motor	B	B	A	A	A	A	A	A	A	A	C	C	C	C	C	C	C	C	C	C	C
	rpm	583	616	648	680	712	740	768	796	820	844	872	896	916	940	964	984	1008	1028	1048	1064	1084
3300	Turns Open	3.5	2.5	5.5	5.0	4.0	3.5	3.0	2.5	1.5	1.5	6.0	5.5	5.0	4.5	4.0	4.0	3.5	3.0	3.0	3.0	2.5
	bhp	0.75	0.81	0.88	0.93	1.00	1.05	1.12	1.18	1.25	1.32	1.38	1.45	1.53	1.61	1.67	1.75	1.80	1.86	1.92	2.00	2.03
	Sheave/Motor	B	A	A	A	A	A	A	A	A	A	A	C	C	C	C	C	C	C	C	C	E
3400	rpm	604	636	668	696	728	752	780	808	832	856	880	904	928	952	972	996	1016	1036	1056	1076	1096
	Turns Open	3.0	6.0	5.0	4.5	4.0	3.0	2.5	2.0	1.5	1.0	5.5	5.0	5.0	4.5	4.0	3.5	3.5	3.0	2.5	2.5	2.0
	bhp	0.80	0.86	0.93	0.99	1.07	1.15	1.23	1.28	1.34	1.39	1.44	1.52	1.61	1.69	1.78	1.86	1.91	1.96	2.01	2.06	2.12
3500	Sheave/Motor	B	A	A	A	A	A	A	A	A	C	C	C	C	C	C	C	C	C	E	E	E
	rpm	620	652	684	712	740	768	796	820	844	868	892	916	940	960	984	1008	1028	1048	1064	1084	1104
	Turns Open	2.5	5.5	5.0	4.0	3.5	3.0	2.5	2.0	1.0	6.0	5.5	5.0	4.5	4.0	4.0	3.5	3.0	3.0	2.5	2.5	2.0
3600	bhp	0.89	0.96	1.03	1.09	1.15	1.22	1.27	1.35	1.42	1.48	1.55	1.63	1.71	1.80	1.87	1.95	2.01	2.07	2.13	2.19	2.25
	Sheave/Motor	A	A	A	A	A	A	A	A	A	C	C	C	C	C	C	C	E	E	E	E	E
	rpm	636	668	696	724	752	780	804	832	856	880	904	924	948	972	992	1016	1036	1056	1076	1096	1112
3700	Turns Open	6.0	5.0	4.5	4.0	3.5	2.5	2.0	1.5	1.0	5.5	5.0	4.5	4.0	3.5	3.0	2.5	2.5	2.0	2.0	2.0	2.0
	bhp	0.95	1.02	1.09	1.17	1.24	1.32	1.38	1.43	1.48	1.53	1.61	1.70	1.80	1.88	2.00	2.04	2.11	2.18	2.25	2.32	2.38
	Sheave/Motor	A	A	A	A	A	A	A	A	C	C	C	C	C	C	E	E	E	E	E	E	E
3800	rpm	652	684	712	740	764	792	816	840	864	888	912	936	960	980	1004	1024	1044	1064	1084	1104	1120
	Turns Open	5.5	4.5	4.0	3.5	3.0	2.5	2.0	1.5	6.0	5.5	5.0	4.5	4.5	4.0	3.5	3.0	3.0	2.5	2.5	2.0	1.5
	bhp	1.05	1.13	1.19	1.25	1.31	1.37	1.44	1.51	1.57	1.64	1.74	1.82	1.91	2.01	2.08	2.14	2.21	2.27	2.33	2.41	2.48
3900	Sheave/Motor	A	A	A	A	A	A	A	A	C	C	C	C	C	E	E	E	E	E	E	E	E
	rpm	668	696	724	752	776	804	828	852	876	900	924	944	968	992	1012	1032	1052	1072	1092	1112	1128
	Turns Open	5.0	4.5	4.0	3.5	3.0	2.0	1.5	1.0	5.5	5.0	5.0	4.5	4.0	3.5	3.5	3.0	3.0	2.5	2.0	2.0	1.5
4000	bhp	1.12	1.18	1.26	1.34	1.41	1.48	1.54	1.61	1.67	1.73	1.82	1.90	1.97	2.06	2.14	2.21	2.29	2.36	2.44	2.53	2.61
	Sheave/Motor	A	A	A	A	A	A	A	C	C	C	C	C	C	E	E	E	E	E	E	E	E
	rpm	680	708	736	764	788	816	840	864	888	908	932	956	976	1000	1020	1040	1060	1080	1100	1120	1136
4100	Turns Open	5.0	4.0	3.5	3.0	2.5	2.0	1.5	6.0	5.5	5.0	4.5	4.5	4.0	3.5	3.0	2.5	2.5	2.0	1.5	1.5	1.5
	bhp	1.23	1.29	1.35	1.41	1.47	1.56	1.64	1.70	1.79	1.87	2.00	2.02	2.10	2.17	2.24	2.31	2.38	2.46	2.54	2.64	2.72
	Sheave/Motor	A	A	A	A	A	A	A	C	C	C	E	E	E	E	E	E	E	E	E	E	E
4200	rpm	696	724	752	776	804	828	852	872	896	920	944	964	988	1008	1028	1048	1068	1088	1108	1128	1144
	Turns Open	4.5	4.0	3.5	3.0	2.0	1.5	1.0	5.5	5.0	5.0	4.5	4.5	4.0	3.5	3.0	3.0	2.5	2.5	2.0	1.5	1.5

**LEGEND**

**bhp** — Brake Horsepower  
**ESP** — External Static Pressure

**NOTES:**

1. A = Standard RPM/Standard Motor, B = Low RPM/Standard Motor, C = High RPM/Standard Motor, E = High RPM/Large Motor

2. Unit shipped with standard drive package with drive sheave 2.5 turns open unless otherwise requested. Field adjustment may be required for specified CFM.
3. ISO/AHRI rating point with standard drive package and drive sheave open 3.0 turns at .30 ESP.
4. Performance data does not include drive losses and is based on sea level conditions.
5. All airflow is rated at lowest voltage if unit is dual rated, i.e., rated at 208 volts for 208-230 volt units.

**Table 8 — 50RTP08 Blower Performance Data (cont)**

AIRFLOW (cfm)	ESP	AIRFLOW (cfm) AT EXTERNAL STATIC PRESSURE (in. wg)																				
		0.0	0.1	0.2	0.3	0.4	0.5	0.6	0.7	0.8	0.9	1.0	1.1	1.2	1.3	1.4	1.5	1.6	1.7	1.8	1.9	2.0
3800	bhp	1.29	1.37	1.44	1.52	1.59	1.67	1.74	1.82	1.89	2.00	2.04	2.12	2.20	2.28	2.36	2.44	2.52	2.60	2.67	2.77	2.84
	Sheave/Motor	A	A	A	A	A	A	C	C	C	E	E	E	E	E	E	E	E	E	E	E	E
	rpm	712	740	764	792	816	840	864	888	908	932	952	976	1000	1020	1040	1060	1080	1100	1116	1136	1152
	Turns Open	4.0	3.5	3.0	2.5	2.0	1.5	6.0	5.5	5.0	4.5	4.5	4.0	3.5	3.0	3.0	2.5	2.5	2.0	2.0	1.5	1.0
3900	bhp	1.41	1.48	1.54	1.61	1.70	1.78	1.84	1.93	2.01	2.08	2.17	2.26	2.33	2.41	2.49	2.57	2.65	2.74	2.81	2.89	—
	Sheave/Motor	A	A	A	A	A	A	C	C	E	E	E	E	E	E	E	E	E	E	E	E	—
	rpm	728	752	776	804	828	852	872	896	920	940	964	988	1008	1028	1048	1068	1088	1108	1124	1144	—
	Turns Open	4.0	3.0	2.5	2.0	1.5	1.0	5.5	5.5	5.0	4.5	4.0	4.0	3.5	3.0	3.0	2.5	2.0	2.0	1.5	1.0	—
4000	bhp	1.48	1.56	1.64	1.71	1.80	1.88	2.00	2.03	2.12	2.19	2.27	2.35	2.43	2.52	2.61	2.69	2.78	2.86	2.93	—	—
	Sheave/Motor	A	A	A	A	A	C	E	E	E	E	E	E	E	E	D	E	E	E	E	—	—
	rpm	740	768	792	816	840	864	888	908	932	952	976	996	1016	1036	1056	1076	1096	1116	1132	—	—
	Turns Open	3.5	3.0	2.5	2.0	1.5	6.0	5.5	5.0	4.5	4.5	4.0	3.5	3.5	3.0	2.5	2.5	2.0	2.0	1.5	—	—

**LEGEND**

**bhp** — Brake Horsepower  
**ESP** — External Static Pressure

**NOTES:**

1. A = Standard RPM/Standard Motor, B = Low RPM/Standard Motor, C = High RPM/Standard Motor, E = High RPM/Large Motor

2. Unit shipped with standard drive package with drive sheave 2.5 turns open unless otherwise requested. Field adjustment may be required for specified CFM.
3. ISO/AHRI rating point with standard drive package and drive sheave open 3.0 turns at .30 ESP.
4. Performance data does not include drive losses and is based on sea level conditions.
5. All airflow is rated at lowest voltage if unit is dual rated, i.e., rated at 208 volts for 208-230 volt units.



**Table 9 — 50RTP10 Blower Performance Data**

AIRFLOW (cfm)	ESP	AIRFLOW (cfm) AT EXTERNAL STATIC PRESSURE (in. wg)																				
		0.0	0.1	0.2	0.3	0.4	0.5	0.6	0.7	0.8	0.9	1.0	1.1	1.2	1.3	1.4	1.5	1.6	1.7	1.8	1.9	2.0
3000	bhp	0.66	0.71	0.76	0.81	0.86	0.94	1.02	1.1	1.17	1.22	1.27	1.32	1.39	1.48	1.56	1.65	1.74	1.78	1.83	1.86	1.91
	Sheave/Motor	B	B	B	B	B	A	A	A	A	A	A	A	A	A	A	C	C	C	C	C	C
	rpm	571	604	636	668	700	728	756	784	812	836	860	884	908	932	952	976	1000	1020	1040	1056	1076
	Turns Open	5.5	5.0	4.0	3.0	2.0	6.0	5.5	5.0	4.0	3.5	3.0	2.5	2.0	1.5	1.0	4.5	4.0	4.0	3.5	3.0	3.0
3100	bhp	0.73	0.79	0.85	0.91	0.98	1.04	1.10	1.16	1.23	1.29	1.36	1.43	1.50	1.58	1.64	1.72	1.78	1.84	1.89	1.95	2.01
	Sheave/Motor	B	B	B	B	A	A	A	A	A	A	A	A	A	A	C	C	C	C	C	C	C
	rpm	592	624	656	684	716	744	772	800	824	848	872	896	920	944	964	988	1008	1028	1048	1068	1088
	Turns Open	5.0	4.5	3.5	2.5	6.0	5.5	4.5	4.0	3.5	3.0	2.5	2.0	1.5	1.0	5.0	4.5	4.0	3.5	3.5	3.0	2.5
3200	bhp	0.78	0.84	0.90	0.97	1.04	1.12	1.20	1.27	1.32	1.37	1.42	1.49	1.58	1.66	1.75	1.84	1.89	1.94	2.00	2.05	2.10
	Sheave/Motor	B	B	B	B	A	A	A	A	A	A	A	A	A	A	C	C	C	C	C	C	C
	rpm	608	640	672	704	728	756	784	812	836	860	884	908	932	952	976	1000	1020	1040	1060	1080	1100
	Turns Open	4.5	4.0	3.0	2.0	5.5	5.0	4.5	4.0	3.5	3.0	2.5	2.0	1.5	1.0	4.5	4.0	4.0	3.5	3.0	3.0	2.5
3300	bhp	0.87	0.93	1.01	1.08	1.14	1.20	1.26	1.33	1.39	1.46	1.53	1.61	1.68	1.77	1.86	1.92	1.98	2.04	2.10	2.16	2.23
	Sheave/Motor	B	B	B	B	A	A	A	A	A	A	A	A	A	C	C	C	C	C	C	C	C
	rpm	628	656	688	716	744	772	800	824	848	872	896	920	940	964	988	1008	1028	1048	1068	1088	1108
	Turns Open	4.0	3.5	2.5	1.5	5.5	4.5	4.0	3.5	3.0	2.5	2.0	1.5	1.0	5.0	4.5	4.0	3.5	3.5	3.0	2.5	2.5
3400	bhp	0.94	1.01	1.07	1.15	1.23	1.30	1.37	1.42	1.47	1.52	1.59	1.69	1.77	1.86	1.96	2.03	2.10	2.16	2.23	2.30	2.36
	Sheave/Motor	B	B	B	A	A	A	A	A	A	A	A	A	A	A	C	C	C	C	C	C	C
	rpm	644	676	704	732	760	784	812	836	860	884	908	932	952	976	1000	1020	1040	1060	1080	1100	1116
	Turns Open	3.5	3.0	2.0	5.5	5.0	4.5	4.0	3.5	3.0	2.5	2.0	1.5	1.0	4.5	4.0	4.0	3.5	3.0	3.0	2.5	2.0
3500	bhp	1.03	1.12	1.18	1.24	1.30	1.36	1.43	1.49	1.56	1.63	1.72	1.80	1.90	1.99	2.07	2.13	2.19	2.26	2.32	2.40	2.47
	Sheave/Motor	B	B	A	A	A	A	A	A	A	A	A	A	C	C	C	C	C	C	C	C	C
	rpm	660	692	720	744	772	800	824	848	872	896	920	940	964	988	1008	1028	1048	1068	1088	1108	1124
	Turns Open	3.5	2.5	6.0	5.5	4.5	4.0	3.5	3.0	2.5	2.0	1.5	1.0	5.0	4.5	4.0	3.5	3.5	3.0	2.5	2.5	2.0
3600	bhp	1.11	1.17	1.25	1.33	1.40	1.47	1.53	1.60	1.66	1.73	1.80	1.89	1.97	2.05	2.12	2.20	2.27	2.35	2.42	2.51	2.59
	Sheave/Motor	B	B	A	A	A	A	A	A	A	A	A	A	C	C	C	C	C	C	C	C	C
	rpm	676	704	732	760	784	812	836	860	884	908	928	952	976	996	1016	1036	1056	1076	1096	1116	1132
	Turns Open	3.0	2.0	5.5	5.0	4.5	4.0	3.5	3.0	2.5	2.0	1.5	1.0	4.5	4.0	4.0	3.5	3.0	3.0	2.5	2.0	2.0
3700	bhp	1.22	1.28	1.35	1.40	1.46	1.54	1.62	1.70	1.77	1.85	1.94	2.00	2.09	2.17	2.24	2.31	2.38	2.46	2.52	2.62	2.72
	Sheave/Motor	B	A	A	A	A	A	A	A	A	A	A	C	C	C	C	C	C	C	C	C	C
	rpm	692	720	748	772	800	824	848	872	892	916	940	960	984	1008	1028	1048	1068	1088	1104	1124	1144
	Turns Open	2.5	6.0	5.0	4.5	4.0	3.5	3.0	2.5	2.0	1.5	1.0	5.0	4.5	4.0	3.5	3.5	3.0	2.5	2.5	2.0	1.5
3800	bhp	1.28	1.35	1.43	1.51	1.58	1.66	1.73	1.81	1.87	1.96	2.04	2.10	2.19	2.26	2.34	2.42	2.50	2.58	2.66	2.75	2.84
	Sheave/Motor	B	A	A	A	A	A	A	A	A	A	A	C	C	C	C	C	C	C	C	C	C
	rpm	708	732	760	788	812	836	860	884	904	928	952	972	996	1016	1036	1056	1076	1096	1112	1132	1152
	Turns Open	2.0	5.5	5.0	4.5	4.0	3.5	3.0	2.5	2.0	1.5	1.0	4.5	4.0	4.0	3.5	3.0	3.0	2.5	2.0	2.0	1.5
3900	bhp	1.39	1.46	1.53	1.60	1.68	1.76	1.83	1.91	2.00	2.08	2.16	2.24	2.32	2.40	2.48	2.56	2.64	2.72	2.81	2.88	3.00
	Sheave/Motor	A	A	A	A	A	A	A	A	A	A	C	C	C	C	C	C	C	C	C	C	E
	rpm	720	748	772	800	824	848	868	892	916	940	960	984	1004	1024	1044	1064	1084	1104	1124	1140	1160
	Turns Open	5.5	5.0	4.5	4.0	3.5	3.0	2.5	2.0	1.5	1.0	5.0	4.5	4.0	3.5	3.5	3.0	2.5	2.5	2.0	2.0	1.5
4000	bhp	1.47	1.54	1.62	1.70	1.78	1.86	1.95	2.01	2.10	2.17	2.26	2.33	2.41	2.50	2.59	2.68	2.76	2.85	2.93	3.00	3.07
	Sheave/Motor	A	A	A	A	A	A	A	A	A	A	C	C	C	C	C	C	C	C	C	E	E
	rpm	736	760	788	812	836	860	884	904	928	948	972	992	1012	1032	1052	1072	1092	1112	1132	1148	1168
	Turns Open	5.5	5.0	4.5	4.0	3.5	3.0	2.5	2.0	1.5	1.0	4.5	4.5	4.0	3.5	3.5	3.0	2.5	2.0	2.0	1.5	1.5
4100	bhp	1.56	1.66	1.74	1.82	1.89	1.97	2.03	2.12	2.20	2.29	2.36	2.46	2.53	2.62	2.72	2.81	2.90	3.00	3.06	3.12	3.20
	Sheave/Motor	A	A	A	A	A	A	A	A	A	C	C	C	C	C	C	C	C	E	E	E	E
	rpm	748	776	800	824	848	872	892	916	936	960	980	1004	1020	1040	1060	1080	1100	1120	1140	1156	1176
	Turns Open	5.0	4.5	4.0	3.5	3.0	2.5	2.0	1.5	1.0	5.0	4.5	4.0	4.0	3.5	3.0	3.0	2.5	2.0	2.0	1.5	1.0
4200	bhp	1.64	1.72	1.81	1.90	1.97	2.06	2.15	2.23	2.31	2.38	2.46	2.56	2.66	2.76	2.86	3.00	3.03	3.11	3.18	3.26	3.34
	Sheave/Motor	A	A	A	A	A	A	A	A	A	C	C	C	C	C	C	E	E	E	E	E	E
	rpm	764	788	812	836	856	880	904	924	948	968	988	1012	1032	1052	1072	1088	1108	1128	1144	1164	1184
	Turns Open	0.66	0.71	0.76	0.81	0.86	0.94	1.02	1.1	1.17	1.22	1.27	1.32	1.39	1.48	1.56	1.65	1.74	1.78	1.83	1.86	1.91

**LEGEND**

**bhp** — Brake Horsepower  
**ESP** — External Static Pressure

**NOTES:**

1. A = Standard RPM/Standard Motor, B = Low RPM/Standard Motor, C = High RPM/Standard Motor, E = High RPM/Large Motor

2. Unit shipped with standard drive package with drive sheave 2.5 turns open unless otherwise requested. Field adjustment may be required for specified CFM.
3. ISO/AHRI rating point with standard drive package and drive sheave open 3.0 turns at .30 ESP.
4. Performance data does not include drive losses and is based on sea level conditions.
5. All airflow is rated at lowest voltage if unit is dual rated, i.e., rated at 208 volts for 208-230 volt units.

**Table 9 — 50RTP10 Blower Performance Data (cont)**

AIRFLOW (cfm)	ESP	AIRFLOW (cfm) AT EXTERNAL STATIC PRESSURE (in. wg)																				
		0.0	0.1	0.2	0.3	0.4	0.5	0.6	0.7	0.8	0.9	1.0	1.1	1.2	1.3	1.4	1.5	1.6	1.7	1.8	1.9	2.0
4300	bhp	1.76	1.84	1.93	2.00	2.08	2.17	2.25	2.34	2.42	2.50	2.60	2.70	2.80	2.90	3.00	3.10	3.16	3.24	3.31	3.39	3.45
	Sheave/Motor	A	A	A	A	A	A	A	A	C	C	C	C	C	C	E	E	E	E	E	E	E
	rpm	776	800	824	844	868	892	912	936	956	976	1000	1020	1040	1060	1080	1100	1116	1136	1152	1172	1188
	Turns Open	4.5	4.0	3.5	3.0	2.5	2.0	1.5	1.0	5.0	4.5	4.0	4.0	3.5	3.0	3.0	2.5	2.0	2.0	1.5	1.0	1.0
4400	bhp	1.86	1.95	2.04	2.12	2.22	2.32	2.4	2.48	2.57	2.65	2.74	2.84	3.00	3.04	3.14	3.23	3.30	3.38	3.44	3.52	3.58
	Sheave/Motor	A	A	A	A	A	A	A	A	C	C	C	C	E	E	E	E	E	E	E	E	E
	rpm	788	812	836	856	880	904	924	944	968	988	1008	1028	1048	1068	1088	1108	1124	1144	1160	1180	1196
	Turns Open	4.5	4.0	3.5	3.0	2.5	2.0	1.5	1.0	4.5	4.5	4.0	3.5	3.5	3.0	2.5	2.5	2.0	1.5	1.5	1.0	1.0
4500	bhp	1.96	2.06	2.15	2.23	2.33	2.43	2.52	2.61	2.69	2.78	2.88	3.00	3.08	3.18	3.28	3.35	3.44	3.53	3.61	3.70	—
	Sheave/Motor	A	A	A	A	A	A	A	C	C	C	E	E	E	E	E	E	E	E	E	E	—
	rpm	800	824	848	868	892	916	936	956	976	996	1016	1036	1056	1076	1096	1112	1132	1152	1168	1188	—
	Turns Open	4.0	3.5	3.0	2.5	2.0	1.5	1.0	5.0	4.5	4.0	4.0	3.5	3.0	3.0	2.5	2.0	2.0	1.5	1.5	1.0	—
4600	bhp	2.12	2.20	2.30	2.38	2.47	2.56	2.64	2.73	2.83	2.92	3.00	3.10	3.20	3.30	3.40	3.49	3.60	3.68	3.79	3.88	—
	Sheave/Motor	A	A	A	A	A	A	A	C	C	C	E	E	E	E	E	E	E	E	E	E	—
	rpm	820	840	864	884	908	928	948	968	992	1012	1028	1048	1068	1088	1108	1124	1144	1160	1180	1196	—
	Turns Open	3.5	3.0	3.0	2.5	2.0	1.5	1.0	4.5	4.5	4.0	3.5	3.5	3.0	2.5	2.5	2.0	1.5	1.5	1.0	1.0	—
4700	bhp	2.23	2.31	2.40	2.50	2.59	2.68	2.76	2.85	3.00	3.04	3.14	3.24	3.34	3.42	3.53	3.62	3.73	3.84	3.93	—	—
	Sheave/Motor	A	A	A	A	A	A	C	C	E	E	E	E	E	E	E	E	E	E	E	E	—
	rpm	832	852	876	900	920	940	960	980	1000	1020	1040	1060	1080	1096	1116	1132	1152	1172	1188	—	—
	Turns Open	3.5	3.0	2.5	2.0	1.5	1.0	5.0	4.5	4.0	4.0	3.5	3.0	3.0	2.5	2.0	2.0	1.5	1.0	1.0	—	—
4800	bhp	2.35	2.46	2.55	2.65	2.73	2.81	2.89	3.00	3.06	3.16	3.26	3.34	3.44	3.55	3.64	3.76	3.86	3.98	4.08	—	—
	Sheave/Motor	A	A	A	A	A	C	C	E	E	E	E	E	E	E	E	E	E	E	E	E	—
	rpm	844	868	888	912	932	952	972	992	1012	1032	1052	1068	1088	1108	1124	1144	1160	1180	1196	—	—
	Turns Open	3.0	2.5	2.0	1.5	1.5	5.0	4.5	4.5	4.0	3.5	3.5	3.0	2.5	2.5	2.0	1.5	1.5	1.0	1.0	—	—
4900	bhp	2.49	2.58	2.68	2.77	2.85	3.00	3.03	3.12	3.22	3.30	3.40	3.50	3.60	3.70	3.82	3.91	4.03	4.13	—	—	—
	Sheave/Motor	A	A	A	A	A	E	E	E	E	E	E	E	E	E	E	E	E	E	—	—	—
	rpm	860	880	904	924	944	964	984	1004	1024	1040	1060	1080	1100	1116	1136	1152	1172	1188	—	—	—
	Turns Open	3.0	2.5	2.0	1.5	1.0	5.0	4.5	4.0	3.5	3.5	3.0	2.5	2.0	2.0	1.5	1.0	1.0	1.0	—	—	—
5000	bhp	2.63	2.72	2.81	2.91	3.00	3.09	3.18	3.28	3.36	3.46	3.56	3.66	3.75	3.87	3.96	4.08	4.18	4.28	—	—	—
	Sheave/Motor	A	A	A	A	E	E	E	E	E	E	E	E	E	E	E	E	E	E	—	—	—
	rpm	876	896	916	936	956	976	996	1016	1032	1052	1072	1092	1108	1128	1144	1164	1180	1196	—	—	—
	Turns Open	2.5	2.0	1.5	1.0	5.0	4.5	4.0	4.0	3.5	3.5	3.0	2.5	2.5	2.0	1.5	1.5	1.0	1.0	—	—	—

**LEGEND**

**bhp** — Brake Horsepower  
**ESP** — External Static Pressure

**NOTES:**

1. A = Standard RPM/Standard Motor, B = Low RPM/Standard Motor, C = High RPM/Standard Motor, E = High RPM/Large Motor

2. Unit shipped with standard drive package with drive sheave 2.5 turns open unless otherwise requested. Field adjustment may be required for specified CFM.
3. ISO/AHRI rating point with standard drive package and drive sheave open 3.0 turns at .30 ESP.
4. Performance data does not include drive losses and is based on sea level conditions.
5. All airflow is rated at lowest voltage if unit is dual rated, i.e., rated at 208 volts for 208-230 volt units.

**Table 10 — 50RTP12 Blower Performance Data**

AIRFLOW (cfm)	ESP	AIRFLOW (cfm) AT EXTERNAL STATIC PRESSURE (in. wg)																				
		0.0	0.1	0.2	0.3	0.4	0.5	0.6	0.7	0.8	0.9	1.0	1.1	1.2	1.3	1.4	1.5	1.6	1.7	1.8	1.9	2.0
3600	bhp	0.86	0.93	1.01	1.10	1.18	1.26	1.36	1.46	1.57	1.68	1.77	1.86	1.94	2.03	2.14	2.27	2.38	2.52	2.70	2.86	3.04
	Sheave/Motor	B	B	B	B	B	A	A	A	A	A	A	A	C	C	C	C	C	C	C	C	E
	rpm	640	672	704	732	760	788	816	840	868	896	924	952	980	1008	1036	1068	1096	1124	1160	1192	1228
3800	Turns Open	5.5	5.0	4.0	3.0	2.0	6.0	5.0	4.5	3.5	3.0	2.0	1.5	6.0	5.5	5.0	4.5	4.0	3.5	3.0	2.5	2.0
	bhp	1.06	1.15	1.24	1.33	1.41	1.51	1.59	1.69	1.77	1.87	1.95	2.03	2.13	2.23	2.36	2.49	2.60	2.74	2.88	3.04	3.18
	Sheave/Motor	B	B	B	B	A	A	A	A	A	A	A	A	C	C	C	C	C	C	C	E	E
4000	rpm	672	704	732	760	788	816	840	868	892	920	944	968	996	1020	1048	1076	1100	1128	1156	1188	1216
	Turns Open	5.0	4.0	3.0	2.0	6.0	5.0	4.5	3.5	3.0	2.0	1.5	1.0	6.0	5.5	5.0	4.0	3.5	3.0	2.5	2.0	2.0
	bhp	1.23	1.31	1.41	1.51	1.61	1.69	1.77	1.87	1.96	2.04	2.13	2.22	2.32	2.44	2.56	2.70	2.81	2.92	3.04	3.16	3.30
4200	Sheave/Motor	B	B	B	A	A	A	A	A	A	A	C	C	C	C	C	C	E	E	E	E	E
	rpm	708	732	760	788	816	840	864	892	916	940	964	988	1012	1036	1060	1088	1112	1136	1164	1192	1216
	Turns Open	4.0	3.0	2.0	6.0	5.0	4.5	4.0	3.0	2.5	1.5	1.0	6.0	5.5	5.0	4.5	4.0	3.5	3.0	2.5	2.0	1.5
4400	bhp	1.25	1.4	1.59	1.71	1.79	1.87	1.97	2.06	2.14	2.24	2.34	2.44	2.55	2.66	2.75	2.86	3.00	3.12	3.25	3.38	3.52
	Sheave/Motor	B	B	A	A	A	A	A	A	A	A	C	C	C	C	C	E	E	E	E	E	E
	rpm	696	736	784	816	840	864	892	916	936	960	984	1008	1032	1056	1076	1100	1124	1148	1172	1196	1220
4600	Turns Open	3.5	3.0	6.0	5.0	4.5	4.0	3.0	2.5	2.0	1.0	6.0	5.5	5.0	4.5	4.0	3.5	3.0	2.5	2.0	1.5	1.5
	bhp	1.56	1.69	1.79	1.88	1.96	2.04	2.14	2.24	2.35	2.45	2.54	2.65	2.74	2.85	2.96	3.07	3.20	3.34	3.45	3.59	3.74
	Sheave/Motor	B	A	A	A	A	A	A	A	A	C	C	C	C	C	C	E	E	E	E	E	E
4800	rpm	752	784	812	836	860	884	908	932	956	980	1000	1024	1044	1068	1092	1112	1136	1160	1180	1204	1228
	Turns Open	2.5	6.0	5.0	4.5	4.0	3.0	2.5	2.0	1.0	6.0	6.0	5.5	5.0	4.5	4.0	3.5	3.0	2.5	2.0	1.5	1.0
	bhp	1.77	1.88	1.96	2.05	2.13	2.22	2.33	2.42	2.53	2.62	2.75	2.85	3.00	3.11	3.22	3.32	3.44	3.54	3.64	3.78	3.92
5000	Sheave/Motor	B	A	A	A	A	A	A	A	C	C	C	C	E	E	E	E	E	E	E	E	E
	rpm	780	808	832	856	880	904	928	948	972	992	1016	1036	1060	1084	1104	1124	1148	1168	1188	1212	1232
	Turns Open	1.5	5.5	4.5	4.0	3.5	2.5	2.0	1.5	1.0	6.0	5.5	5.0	4.5	4.0	3.5	3.0	2.5	2.0	2.0	1.5	1.0
5200	bhp	1.98	2.08	2.17	2.27	2.37	2.48	2.57	2.67	2.76	2.89	3.00	3.11	3.22	3.33	3.44	3.55	3.68	3.79	3.9	4.04	4.18
	Sheave/Motor	A	A	A	A	A	A	A	A	C	C	E	E	E	E	E	E	E	E	E	E	E
	rpm	808	832	856	880	904	928	948	972	992	1016	1036	1056	1076	1096	1116	1136	1160	1180	1200	1220	1240
5400	Turns Open	5.5	4.5	4.0	3.5	2.0	1.5	1.0	1.0	6.0	5.5	5.0	4.5	4.0	3.5	3.5	3.0	2.5	2.0	1.5	1.0	1.0
	bhp	2.18	2.30	2.41	2.52	2.61	2.71	2.80	2.89	3.01	3.12	3.23	3.34	3.46	3.57	3.69	3.81	3.93	4.05	4.18	4.32	—
	Sheave/Motor	A	A	A	A	A	A	A	C	E	E	E	E	E	E	E	E	E	E	E	E	—
5600	rpm	828	856	880	904	924	948	968	988	1012	1032	1052	1072	1092	1112	1132	1152	1172	1192	1212	1232	—
	Turns Open	4.5	4.0	3.5	2.5	2.0	1.5	1.0	6.0	5.5	5.0	4.5	4.5	4.0	3.5	3.0	2.5	2.0	1.5	1.5	1.0	—
	bhp	2.41	2.50	2.60	2.72	2.82	2.94	3.04	3.17	3.29	3.44	3.58	3.70	3.82	3.92	4.01	4.13	4.23	4.33	4.47	—	—
5800	Sheave/Motor	A	A	A	A	A	A	A	E	E	E	E	E	E	E	E	E	E	E	E	—	—
	rpm	852	876	900	924	944	968	988	1012	1032	1056	1080	1100	1120	1136	1152	1172	1188	1204	1224	—	—
	Turns Open	4.0	3.5	2.5	2.0	1.0	1.0	6.0	5.5	5.0	4.5	4.0	4.0	3.0	3.0	2.5	2.0	2.0	1.5	1.0	—	—
6000	bhp	2.64	2.75	2.87	3.00	3.10	3.20	3.30	3.41	3.52	3.63	3.74	3.86	4.00	4.11	4.25	4.39	4.53	4.64	4.78	—	—
	Sheave/Motor	A	A	A	D	D	E	E	E	E	E	E	E	E	E	E	E	E	E	E	—	—
	rpm	876	900	924	944	968	988	1008	1028	1048	1068	1088	1108	1128	1144	1164	1184	1204	1220	1240	—	—
6200	Turns Open	3.5	3.0	2.0	1.5	1.0	6.0	5.5	5.0	5.0	4.5	4.0	3.5	3.0	2.5	2.5	2.0	1.5	1.0	1.0	—	—
	bhp	2.88	2.98	3.10	3.20	3.32	3.42	3.54	3.66	3.78	3.90	4.03	4.14	4.28	4.42	4.53	4.67	4.78	4.92	—	—	—
	Sheave/Motor	A	D	D	D	E	E	E	E	E	E	E	E	E	E	E	E	E	E	—	—	—
6400	rpm	896	916	940	960	984	1004	1024	1044	1064	1084	1104	1120	1140	1160	1176	1196	1212	1232	—	—	—
	Turns Open	3.0	2.5	1.5	1.0	6.0	5.5	5.5	5.0	4.5	4.0	3.5	3.0	3.0	2.5	2.0	1.5	1.5	1.0	—	—	—
	bhp	3.12	3.25	3.36	3.47	3.60	3.72	3.84	3.96	4.08	4.18	4.31	4.45	4.56	4.70	4.84	4.96	—	—	—	—	—
6600	Sheave/Motor	D	D	D	E	E	E	E	E	E	E	E	E	E	E	E	—	—	—	—	—	—
	rpm	912	936	956	976	1000	1020	1040	1060	1080	1096	1116	1136	1152	1172	1192	1208	—	—	—	—	—
	Turns Open	2.5	2.0	1.0	6.0	6.0	5.5	5.0	4.5	4.0	4.0	3.5	3.0	2.5	2.0	1.5	1.5	—	—	—	—	—
6800	bhp	3.36	3.49	3.63	3.74	3.86	3.99	4.12	4.25	4.37	4.48	4.62	4.76	4.88	—	—	—	—	—	—	—	—
	Sheave/Motor	D	D	D	E	E	E	E	E	E	E	E	E	E	—	—	—	—	—	—	—	—
	rpm	928	952	976	996	1016	1036	1056	1076	1096	1112	1132	1152	1168	—	—	—	—	—	—	—	—
7000	Turns Open	2.0	1.5	1.0	6.0	5.5	5.0	4.5	4.0	3.5	3.5	3.0	2.5	2.0	—	—	—	—	—	—	—	—

**LEGEND**

**bhp** — Brake Horsepower  
**ESP** — External Static Pressure

**NOTES:**

1. A = Standard RPM/Standard Motor, B = Low RPM/Standard Motor, C = High RPM/Standard Motor, D = Standard RPM/ Large Motor, E = High RPM/Large Motor

2. Unit shipped with standard drive package with drive sheave 2.5 turns open unless otherwise requested. Field adjustment may be required for specified CFM.
3. ISO/AHRI rating point with standard drive package and drive sheave open 3.0 turns at .30 ESP.
4. Performance data does not include drive losses and is based on sea level conditions.
5. All airflow is rated at lowest voltage if unit is dual rated, i.e., rated at 208 volts for 208-230 volt units.

**Table 11 — 50RTP14 Blower Performance Data**

AIRFLOW (cfm)	ESP	AIRFLOW (cfm) AT EXTERNAL STATIC PRESSURE (in. wg)																							
		0.0	0.1	0.2	0.3	0.4	0.5	0.6	0.7	0.8	0.9	1.0	1.1	1.2	1.3	1.4	1.5	1.6	1.7	1.8	1.9	2.0			
4200	bhp	—	—	—	—	0.83	0.91	0.99	1.06	1.15	1.25	1.35	1.45	1.54	1.64	1.72	1.82	1.91	1.99	2.06	2.14	2.22			
	Sheave/Motor	—	—	—	—	B	B	B	A	A	A	A	A	A	A	C	C	C	C	C	C	C			
	rpm	—	—	—	—	575	612	644	676	708	736	764	792	816	840	860	884	908	928	944	964	984			
	Turns Open	—	—	—	—	5.5	4.0	3.0	6.0	5.0	4.5	3.5	2.5	2.0	1.5	1.0	5.5	5.0	4.5	4.0	3.5	3.0			
4400	bhp	—	—	—	—	0.89	0.98	1.08	1.17	1.25	1.34	1.43	1.52	1.63	1.74	1.85	1.94	2.04	2.12	2.20	2.28	2.36			
	Sheave/Motor	—	—	—	—	B	B	B	A	A	A	A	A	A	A	C	C	C	C	C	C	C			
	rpm	—	—	—	—	587	620	656	688	716	744	772	800	824	848	872	892	916	936	956	976	996			
	Turns Open	—	—	—	—	5.0	4.0	2.5	5.5	4.5	4.0	3.0	2.5	2.0	1.0	5.5	5.0	4.5	4.0	4.0	3.5	3.0			
4600	bhp	—	—	—	—	0.86	0.95	1.06	1.16	1.28	1.36	1.43	1.50	1.60	1.73	1.85	1.98	2.10	2.18	2.26	2.34	2.42	2.50		
	Sheave/Motor	—	—	—	—	B	B	B	A	A	A	A	A	A	C	C	C	C	C	C	C	C			
	rpm	—	—	—	—	558	596	632	664	700	728	752	780	808	832	856	880	904	924	944	964	984	1004		
	Turns Open	—	—	—	—	6.0	4.5	3.5	2.5	5.0	4.5	4.0	3.0	2.0	1.5	1.0	5.5	5.0	4.5	4.0	3.5	3.0	2.5		
4800	bhp	—	—	—	—	0.93	1.01	1.13	1.24	1.34	1.42	1.49	1.57	1.68	1.81	1.93	2.06	2.18	2.27	2.37	2.47	2.56	2.66		
	Sheave/Motor	—	—	—	—	B	B	B	A	A	A	A	A	A	A	C	C	C	C	C	C	C			
	rpm	—	—	—	—	571	604	640	676	708	736	760	788	816	840	864	888	912	932	952	972	992	1012		
	Turns Open	—	—	—	—	5.5	4.5	3.0	6.0	5.0	4.0	3.5	3.0	2.0	1.5	6.0	5.0	4.5	4.0	3.5	3.0	2.5	2.5		
5000	bhp	—	—	—	—	1.03	1.13	1.25	1.36	1.45	1.54	1.62	1.71	1.83	1.99	2.12	2.26	2.35	2.46	2.54	2.63	2.72	2.83		
	Sheave/Motor	—	—	—	—	B	B	B	A	A	A	A	A	A	A	C	C	C	C	C	C	C	C		
	rpm	—	—	—	—	583	616	652	688	716	744	768	796	820	848	872	896	916	940	960	980	1000	1020		
	Turns Open	—	—	—	—	5.0	4.0	2.5	5.5	4.5	4.0	3.5	2.5	2.0	1.0	5.5	5.0	4.5	4.0	3.5	3.0	3.0	2.5		
5200	bhp	—	—	—	—	1.02	1.11	1.22	1.34	1.47	1.58	1.69	1.78	1.90	2.00	2.13	2.23	2.34	2.45	2.59	2.70	2.84	3.00	3.03	
	Sheave/Motor	—	—	—	—	B	B	B	A	A	A	A	A	A	A	C	C	C	C	C	C	C	E		
	rpm	—	—	—	—	558	596	628	660	696	724	752	776	804	828	856	880	904	924	948	968	992	1012	1028	
	Turns Open	—	—	—	—	6.0	4.5	3.5	2.5	5.5	4.5	4.0	3.0	2.5	1.5	1.0	5.5	5.0	4.5	4.0	3.5	3.0	2.5	2.0	
5400	bhp	—	—	—	—	1.12	1.21	1.33	1.43	1.54	1.65	1.76	1.86	1.99	2.12	2.26	2.41	2.54	2.65	2.77	2.88	3.00	3.10	3.19	
	Sheave/Motor	—	—	—	—	B	B	B	A	A	A	A	A	A	A	C	C	C	C	C	E	E	E		
	rpm	—	—	—	—	571	604	640	672	704	732	760	784	812	836	860	888	912	932	956	976	1000	1020	1036	
	Turns Open	—	—	—	—	5.5	4.5	3.0	6.0	5.0	4.5	3.5	3.0	2.0	1.5	1.0	5.0	4.5	4.5	4.0	3.5	3.0	2.5	2.0	
5600	bhp	—	—	—	—	1.23	1.33	1.43	1.54	1.66	1.79	1.91	2.04	2.17	2.27	2.38	2.50	2.63	2.79	3.00	3.09	3.24	3.32	3.41	
	Sheave/Motor	—	—	—	—	B	B	B	A	A	A	A	A	A	A	C	C	C	C	E	E	E	E	E	
	rpm	—	—	—	—	583	616	648	680	712	740	764	792	820	844	868	896	916	940	964	984	1008	1024	1044	
	Turns Open	—	—	—	—	5.0	4.0	3.0	5.5	5.0	4.0	3.5	2.5	2.0	1.5	6.0	5.0	4.5	4.0	3.5	3.0	2.5	2.5	2.0	
5800	bhp	—	—	—	—	1.22	1.31	1.42	1.54	1.65	1.77	1.89	2.01	2.12	2.28	2.41	2.55	2.71	2.83	3.00	3.14	3.27	3.40	3.47	3.57
	Sheave/Motor	—	—	—	—	B	B	B	A	A	A	A	A	A	A	C	C	C	E	E	E	E	E	E	
	rpm	—	—	—	—	563	596	628	660	692	720	748	776	800	828	852	876	904	924	948	972	992	1016	1032	1052
	Turns Open	—	—	—	—	5.5	4.5	3.5	2.5	5.5	4.5	4.0	3.0	2.5	1.5	1.0	5.5	5.0	4.5	4.0	3.5	3.0	2.5	2.0	1.5
6000	bhp	—	—	—	—	1.33	1.43	1.53	1.63	1.74	1.90	2.06	2.21	2.33	2.46	2.56	2.67	2.81	3.00	3.15	3.33	3.48	3.57	3.66	3.74
	Sheave/Motor	—	—	—	—	B	B	B	A	A	A	A	A	A	A	C	E	E	E	E	E	E	E	E	
	rpm	—	—	—	—	575	608	640	672	704	732	760	788	812	840	864	888	912	932	956	980	1000	1020	1040	1060
	Turns Open	—	—	—	—	5.5	4.0	3.0	6.0	5.0	4.5	3.5	3.0	2.0	1.5	1.0	5.0	4.5	4.0	3.5	3.0	2.5	2.0	1.5	
6200	bhp	1.35	1.44	1.56	1.69	1.82	1.95	2.07	2.18	2.30	2.45	2.59	2.72	2.86	3.05	3.14	3.29	3.44	3.56	3.68	3.79	3.90			
	Sheave/Motor	B	B	B	B	A	A	A	A	A	A	A	A	C	C	E	E	E	E	E	E	E	E	E	
	rpm	558	587	620	652	684	716	744	768	796	824	848	872	896	920	940	964	988	1008	1028	1048	1068			
	Turns Open	6.0	5.0	4.0	2.5	5.5	4.5	4.0	3.5	2.5	2.0	1.5	5.5	5.0	4.5	4.0	3.5	3.0	2.5	2.0	2.0	2.0	1.5		

**LEGEND**

**bhp** — Brake Horsepower  
**ESP** — External Static Pressure

**NOTES:**

1. A = Standard RPM/Standard Motor, B = Low RPM/Standard Motor, C = High RPM/Standard Motor, D = Standard RPM/Large Motor, E = High RPM/Large Motor

2. Unit shipped with standard drive package with drive sheave 2.5 turns open unless otherwise requested. Field adjustment may be required for specified CFM.
3. ISO/AHRI rating point with standard drive package and drive sheave open 3.0 turns at .30 ESP.
4. Performance data does not include drive losses and is based on sea level conditions.
5. All airflow is rated at lowest voltage if unit is dual rated, i.e., rated at 208 volts for 208-230 volt units.

**Table 11 — 50RTP14 Blower Performance Data (cont)**

AIRFLOW (cfm)	ESP	AIRFLOW (cfm) AT EXTERNAL STATIC PRESSURE (in. wg)																				
		0.0	0.1	0.2	0.3	0.4	0.5	0.6	0.7	0.8	0.9	1.0	1.1	1.2	1.3	1.4	1.5	1.6	1.7	1.8	1.9	2.0
6400	bhp	1.43	1.54	1.66	1.78	1.90	2.05	2.21	2.37	2.52	2.62	2.73	2.83	2.95	3.13	3.28	3.47	3.65	3.76	3.87	3.97	4.08
	Sheave/Motor	B	B	B	B	A	A	A	A	A	A	A	C	C	E	E	E	E	E	E	E	E
	rpm	571	604	636	664	696	724	752	780	808	832	856	880	904	928	948	972	996	1016	1036	1056	1076
	Turns Open	5.5	4.5	3.5	2.5	5.5	4.5	4.0	3.0	2.5	1.5	1.0	5.5	5.0	4.5	4.0	3.5	3.0	2.5	2.0	1.5	1.0
6600	bhp	1.55	1.68	1.83	1.96	2.12	2.24	2.36	2.47	2.61	2.74	3.00	3.01	3.17	3.34	3.48	3.66	3.82	3.94	4.06	4.16	4.28
	Sheave/Motor	B	B	B	A	A	A	A	A	A	A	D	E	E	E	E	E	E	E	E	E	E
	rpm	583	616	648	676	708	736	764	788	816	840	864	888	912	936	956	980	1004	1024	1044	1060	1080
	Turns Open	5.0	4.0	3.0	6.0	5.0	4.0	3.5	3.0	2.0	1.5	1.0	5.0	4.5	4.0	3.5	3.0	2.5	2.5	2.0	1.5	1.0
6800	bhp	1.68	1.80	1.94	2.08	2.23	2.37	2.52	2.68	2.79	3.00	3.07	3.10	3.28	3.47	3.63	3.82	3.97	4.11	4.25	4.38	4.52
	Sheave/Motor	B	B	B	A	A	A	A	A	A	D	D	E	E	E	E	E	E	E	E	E	E
	rpm	600	628	660	692	720	744	772	800	824	848	872	896	920	944	964	988	1008	1028	1048	1068	1088
	Turns Open	4.5	3.5	2.5	5.5	4.5	4.0	3.0	2.5	2.0	1.0	1.0	5.0	4.5	4.0	3.5	3.0	2.5	2.0	1.5	1.5	1.0
7000	bhp	1.79	1.97	2.12	2.3	2.4	2.53	2.65	2.76	2.9	3.10	3.17	3.31	3.50	3.66	3.86	4.05	4.18	4.31	4.44	4.57	4.69
	Sheave/Motor	B	B	A	A	A	A	A	A	A	D	E	E	E	E	E	E	E	E	E	E	E
	rpm	612	644	672	704	728	756	784	808	832	856	880	904	928	948	972	996	1016	1036	1056	1076	1096
	Turns Open	4.0	3.0	6.0	5.0	4.5	3.5	3.0	2.5	1.5	1.0	5.5	5.0	4.5	4.0	3.5	3.0	2.5	2.0	1.5	1.0	1.0

**LEGEND**

**bhp** — Brake Horsepower  
**ESP** — External Static Pressure

**NOTES:**

1. A = Standard RPM/Standard Motor, B = Low RPM/Standard Motor, C = High RPM/Standard Motor, D = Standard RPM/ Large Motor, E = High RPM/Large Motor

2. Unit shipped with standard drive package with drive sheave 2.5 turns open unless otherwise requested. Field adjustment may be required for specified CFM.
3. ISO/AHRI rating point with standard drive package and drive sheave open 3.0 turns at .30 ESP.
4. Performance data does not include drive losses and is based on sea level conditions.
5. All airflow is rated at lowest voltage if unit is dual rated, i.e., rated at 208 volts for 208-230 volt units.

**Table 12 — 50RTP20 Blower Performance Data**

AIRFLOW (cfm)	ESP	AIRFLOW (cfm) AT EXTERNAL STATIC PRESSURE (in. wg)																				
		0.0	0.1	0.2	0.3	0.4	0.5	0.6	0.7	0.8	0.9	1.0	1.1	1.2	1.3	1.4	1.5	1.6	1.7	1.8	1.9	2.0
6,000	bhp	—	1.50	1.60	1.71	1.85	2.01	2.17	2.32	2.42	2.53	2.63	2.75	2.93	3.12	3.27	3.45	3.55	3.64	3.73	3.81	3.88
	Sheave/Motor	—	B	B	B	B	B	A	A	A	A	A	A	A	A	A	C	C	C	C	C	C
	rpm	—	632	664	696	724	752	780	808	832	856	880	904	928	952	972	996	1016	1036	1056	1076	1092
	Turns Open	—	6.0	5.5	4.5	3.5	2.5	6.0	5.5	4.5	4.0	3.5	2.5	2.0	1.5	1.0	0.0	5.5	5.0	4.5	4.0	4.0
6,200	bhp	—	1.67	1.80	1.93	2.06	2.18	2.30	2.43	2.57	2.70	2.84	2.98	3.14	3.26	3.42	3.56	3.68	3.77	3.88	3.99	4.11
	Sheave/Motor	—	B	B	B	B	B	A	A	A	A	A	A	A	A	A	C	C	C	C	C	C
	rpm	—	648	680	712	740	768	796	820	844	868	892	916	940	960	984	1008	1028	1044	1064	1084	1104
	Turns Open	—	5.5	5.0	3.5	3.0	2.0	5.5	5.0	4.5	3.5	3.0	2.5	1.5	1.0	0.5	6.0	5.0	5.0	4.5	4.0	3.5
6,400	bhp	1.66	1.79	1.90	2.05	2.21	2.37	2.52	2.62	2.73	2.83	2.95	3.13	3.32	3.47	3.65	3.76	3.87	3.97	4.08	4.18	4.33
	Sheave/Motor	B	B	B	B	B	A	A	A	A	A	A	A	A	A	C	C	C	C	C	C	C
	rpm	636	668	696	724	752	780	808	832	856	880	904	928	952	972	996	1016	1036	1056	1076	1096	1116
	Turns Open	6.0	5.0	4.5	3.5	2.5	6.0	5.5	4.5	4.0	3.5	2.5	2.0	1.5	1.0	0.0	5.5	5.0	4.5	4.0	3.5	3.5
6,600	bhp	1.85	2	2.13	2.26	2.38	2.50	2.63	2.77	2.90	3.04	3.20	3.37	3.51	3.68	3.85	3.97	4.09	4.18	4.30	4.43	4.59
	Sheave/Motor	B	B	B	B	B	A	A	A	A	A	A	A	A	A	C	C	C	C	C	C	C
	rpm	652	684	712	740	768	796	820	844	868	892	916	940	960	984	1008	1028	1048	1064	1084	1104	1124
	Turns Open	5.5	4.5	3.5	3.0	2.0	5.5	5.0	4.5	3.5	3.0	2.5	1.5	1.0	0.5	6.0	5.0	4.5	4.5	4.0	3.5	3.0
6,800	bhp	2.00	2.14	2.28	2.43	2.57	2.72	2.82	2.93	3.03	3.15	3.34	3.54	3.70	3.89	4.03	4.16	4.30	4.44	4.57	4.73	4.86
	Sheave/Motor	B	B	B	B	A	A	A	A	A	A	A	A	A	A	C	C	C	C	C	C	C
	rpm	672	704	728	756	780	808	832	856	880	904	928	952	972	996	1016	1036	1056	1076	1096	1116	1132
	Turns Open	5.0	4.0	3.0	2.5	6.0	5.5	4.5	4.0	3.5	2.5	2.0	1.5	1.0	0.0	5.5	5.0	4.5	4.0	3.5	3.5	3.0
7,000	bhp	2.21	2.35	2.47	2.58	2.70	2.83	2.97	3.10	3.24	3.41	3.60	3.76	3.95	4.13	4.26	4.36	4.49	4.62	4.76	5.00	5.07
	Sheave/Motor	B	B	B	B	A	A	A	A	A	A	A	A	A	C	C	C	C	C	C	C	E
	rpm	688	716	744	768	796	820	844	868	892	916	940	960	984	1008	1028	1044	1064	1084	1104	1124	1140
	Turns Open	4.5	3.5	2.5	2.0	5.5	5.0	4.5	3.5	3.0	2.5	1.5	1.0	0.5	6.0	5.0	5.0	4.5	4.0	3.5	3.0	3.0
7,200	bhp	2.34	2.5	2.66	2.79	2.94	3.07	3.17	3.30	3.43	3.60	3.77	3.92	4.09	4.24	4.39	4.55	4.70	4.85	5.03	5.17	5.36
	Sheave/Motor	B	B	B	A	A	A	A	A	A	A	A	A	A	A	C	C	C	C	C	E	E
	rpm	704	732	760	784	812	836	856	880	904	928	952	972	996	1016	1036	1056	1076	1096	1116	1132	1152
	Turns Open	4.0	3.0	2.0	6.0	5.0	4.5	4.0	3.5	2.5	2.0	1.5	1.0	0.0	5.5	5.0	4.5	4.0	4.0	3.5	3.0	2.5
7,400	bhp	2.57	2.69	2.80	2.92	3.08	3.25	3.41	3.57	3.71	3.87	4.04	4.17	4.34	4.48	4.63	4.77	4.91	5.08	5.24	5.44	5.60
	Sheave/Motor	B	B	B	A	A	A	A	A	A	A	A	A	A	C	C	C	C	E	E	E	E
	rpm	720	748	772	800	824	848	872	896	916	940	964	984	1008	1028	1048	1068	1088	1108	1124	1144	1160
	Turns Open	3.5	2.5	1.5	5.5	5.0	4.0	3.5	3.0	2.5	1.5	1.0	0.5	6.0	5.0	5.0	4.5	4.0	3.5	3.0	2.5	2.5
7,600	bhp	2.72	2.88	3.01	3.18	3.31	3.46	3.62	3.77	3.94	4.07	4.24	4.37	4.53	4.69	4.85	5.01	5.17	5.35	5.53	5.68	5.86
	Sheave/Motor	B	A	A	A	A	A	A	A	A	A	A	A	C	C	C	E	E	E	E	E	E
	rpm	736	764	788	816	836	860	884	908	932	952	976	996	1016	1036	1056	1076	1096	1116	1136	1152	1172
	Turns Open	3.0	2.0	6.0	5.0	4.5	4.0	3.0	2.5	2.0	1.5	0.5	0.0	5.5	5.0	4.5	4.5	4.0	3.5	3.0	2.5	2.0
7,800	bhp	2.95	3.10	3.23	3.39	3.55	3.72	3.88	4.02	4.20	4.34	4.51	4.66	4.82	4.98	5.14	5.30	5.47	5.61	5.79	5.96	6.10
	Sheave/Motor	B	A	A	A	A	A	A	A	A	A	A	C	C	C	E	E	E	E	E	E	E
	rpm	752	780	804	828	852	876	900	920	944	964	988	1008	1028	1048	1068	1088	1108	1124	1144	1164	1180
	Turns Open	2.5	6.0	5.5	4.5	4.0	3.5	3.0	2.0	1.5	1.0	0.5	6.0	5.0	4.5	4.0	3.5	3.0	2.5	2.5	2.5	2.0
8,000	bhp	3.13	3.30	3.46	3.59	3.76	3.92	4.09	4.23	4.40	4.55	4.72	4.90	5.07	5.25	5.42	5.60	5.73	5.89	6.05	6.18	6.34
	Sheave/Motor	B	A	A	A	A	A	A	A	A	A	A	C	E	E	E	E	E	E	E	E	E
	rpm	768	796	820	840	864	888	912	932	956	976	1000	1020	1040	1060	1080	1100	1116	1136	1156	1172	1192
	Turns Open	2.0	5.5	5.0	4.5	4.0	3.0	2.5	2.0	1.0	0.5	0.0	5.5	5.0	4.5	4.0	3.5	3.5	3.0	2.5	2.0	1.5
8,200	bhp	3.37	3.53	3.68	3.84	3.99	4.15	4.30	4.48	4.64	4.79	5.00	5.17	5.36	5.54	5.73	5.86	6.02	6.18	6.31	6.47	6.60
	Sheave/Motor	A	A	A	A	A	A	A	A	A	A	E	E	E	E	E	E	E	E	E	E	E
	rpm	784	808	832	856	880	904	924	948	968	988	1012	1032	1052	1072	1092	1108	1128	1148	1164	1184	1200
	Turns Open	6.0	5.5	4.5	4.0	3.5	2.5	2.0	1.5	1.0	0.5	5.5	5.0	4.5	4.5	4.0	3.5	3.0	2.5	2.5	2.0	1.5
8,400	bhp	3.52	3.70	3.88	4.07	4.22	4.40	4.54	4.71	4.86	5.00	5.20	5.40	5.60	5.80	6.00	6.16	6.32	6.45	6.61	6.74	—
	Sheave/Motor	A	A	A	A	A	A	A	A	A	D	E	E	E	E	E	E	E	E	E	E	—
	rpm	800	824	848	872	892	916	936	960	980	1000	1020	1040	1060	1080	1100	1120	1140	1156	1176	1192	—
	Turns Open	5.5	5.0	4.0	3.5	3.0	2.5	2.0	1.0	0.5	0.0	5.5	5.0	4.5	4.0	3.5	3.0	3.0	2.5	2.0	1.5	—

**LEGEND**

**bhp** — Brake Horsepower  
**ESP** — External Static Pressure

**NOTES:**

1. A = Standard RPM/Standard Motor, B = Low RPM/Standard Motor, C = High RPM/Standard Motor, D = Standard RPM/ Large Motor, E = High RPM/Large Motor

2. Unit shipped with standard drive package with drive sheave 2.5 turns open unless otherwise requested. Field adjustment may be required for specified CFM.
3. ISO/AHRI rating point with standard drive package and drive sheave open 3.0 turns at .30 ESP.
4. Performance data does not include drive losses and is based on sea level conditions.
5. All airflow is rated at lowest voltage if unit is dual rated, i.e., rated at 208 volts for 208-230 volt units.

**Table 12 — 50RTP20 Blower Performance Data (cont)**

AIRFLOW (cfm)	ESP	AIRFLOW (cfm) AT EXTERNAL STATIC PRESSURE (in. wg)																				
		0.0	0.1	0.2	0.3	0.4	0.5	0.6	0.7	0.8	0.9	1.0	1.1	1.2	1.3	1.4	1.5	1.6	1.7	1.8	1.9	2.0
8,600	bhp	3.80	3.97	4.11	4.28	4.46	4.62	4.78	5.00	5.14	5.32	5.52	5.72	5.92	6.12	6.30	6.46	6.58	6.74	6.87	—	—
	Sheave/Motor	A	A	A	A	A	A	A	D	D	E	E	E	E	E	E	E	E	E	E	—	—
	rpm	816	840	860	884	908	928	948	972	992	1012	1032	1052	1072	1092	1112	1132	1148	1168	1184	—	—
8,800	Turns Open	5.0	4.5	4.0	3.0	2.5	2.0	1.5	1.0	0.0	5.5	5.0	4.5	4.0	3.5	3.0	3.0	2.5	2.0	2.0	—	—
	bhp	4.06	4.25	4.41	4.60	4.76	5.00	5.11	5.27	5.44	5.64	5.84	6.04	6.24	6.43	6.56	6.72	6.88	7.01	7.17	—	—
	Sheave/Motor	A	A	A	A	A	D	D	D	D	E	E	E	E	E	E	E	E	E	E	—	—
9,000	rpm	832	856	876	900	920	944	964	984	1004	1024	1044	1064	1084	1104	1120	1140	1160	1176	1196	—	—
	Turns Open	4.5	4.0	3.5	3.0	2.0	1.5	1.0	0.5	0.0	5.5	5.0	4.5	4.0	3.5	3.0	3.0	2.5	2.0	1.5	—	—
	bhp	4.30	4.50	4.66	4.86	5.04	5.21	5.39	5.56	5.76	5.96	6.16	6.36	6.56	6.71	6.89	7.07	7.21	7.39	—	—	—
9,200	Sheave/Motor	A	A	A	A	D	D	D	D	E	E	E	E	E	E	E	E	E	E	—	—	—
	rpm	848	872	892	916	936	956	976	996	1016	1036	1056	1076	1096	1112	1132	1152	1168	1188	—	—	—
	Turns Open	4.0	3.5	3.0	2.5	2.0	1.0	0.5	0.0	5.5	5.0	4.5	4.0	3.5	3.0	2.5	2.5	2.0	2.0	—	—	—
9,400	bhp	4.62	4.78	5.00	5.15	5.32	5.48	5.65	5.84	6.04	6.24	6.44	6.64	6.81	7.02	7.20	7.41	—	—	—	—	—
	Sheave/Motor	A	A	D	D	D	D	D	D	E	E	E	E	E	E	E	E	—	—	—	—	—
	rpm	868	888	912	932	952	972	992	1012	1032	1052	1072	1092	1108	1128	1144	1164	—	—	—	—	—
9,600	Turns Open	3.5	3.0	2.5	2.0	1.5	1.0	0.0	5.5	5.0	4.5	4.0	3.5	3.0	2.5	2.5	—	—	—	—	—	—
	bhp	4.87	5.07	5.25	5.42	5.60	5.77	5.96	6.16	6.36	6.56	6.72	6.92	7.15	7.33	—	—	—	—	—	—	—
	Sheave/Motor	A	D	D	D	D	D	D	E	E	E	E	E	E	E	E	—	—	—	—	—	—
9,800	rpm	884	908	928	948	968	988	1008	1028	1048	1068	1084	1104	1124	1140	—	—	—	—	—	—	—
	Turns Open	3.0	2.5	2.0	1.5	1.0	0.5	0.0	5.0	5.0	4.5	4.0	3.5	3.0	3.0	—	—	—	—	—	—	—
	bhp	5.23	5.39	5.55	5.71	5.87	6.04	6.24	6.44	6.64	6.80	7.00	7.24	7.43	—	—	—	—	—	—	—	—
9,800	Sheave/Motor	D	D	D	D	D	D	E	E	E	E	E	E	—	—	—	—	—	—	—	—	—
	rpm	904	924	944	964	984	1004	1024	1044	1064	1080	1100	1120	1136	—	—	—	—	—	—	—	—
	Turns Open	2.5	2.0	1.5	1.0	0.5	0.0	5.5	5.0	4.5	4.0	3.5	3.0	3.0	—	—	—	—	—	—	—	—
10,000	bhp	5.50	5.67	5.85	6.02	6.20	6.40	6.60	6.80	6.96	7.16	7.39	—	—	—	—	—	—	—	—	—	—
	Sheave/Motor	D	D	D	D	D	E	E	E	E	E	E	—	—	—	—	—	—	—	—	—	—
	rpm	920	940	960	980	1000	1020	1040	1060	1076	1096	1116	—	—	—	—	—	—	—	—	—	—
10,000	Turns Open	2.0	1.5	1.0	0.5	0.0	5.5	5.0	4.5	4.0	4.0	3.5	—	—	—	—	—	—	—	—	—	—
	bhp	5.85	6.00	6.18	6.36	6.56	6.76	6.96	7.16	7.32	—	—	—	—	—	—	—	—	—	—	—	—
	Sheave/Motor	D	D	D	D	E	E	E	E	E	—	—	—	—	—	—	—	—	—	—	—	—
10,000	rpm	940	956	976	996	1016	1036	1056	1076	1092	—	—	—	—	—	—	—	—	—	—	—	—
	Turns Open	1.5	1.0	0.5	0.0	5.5	5.0	4.5	4.0	4.0	—	—	—	—	—	—	—	—	—	—	—	—

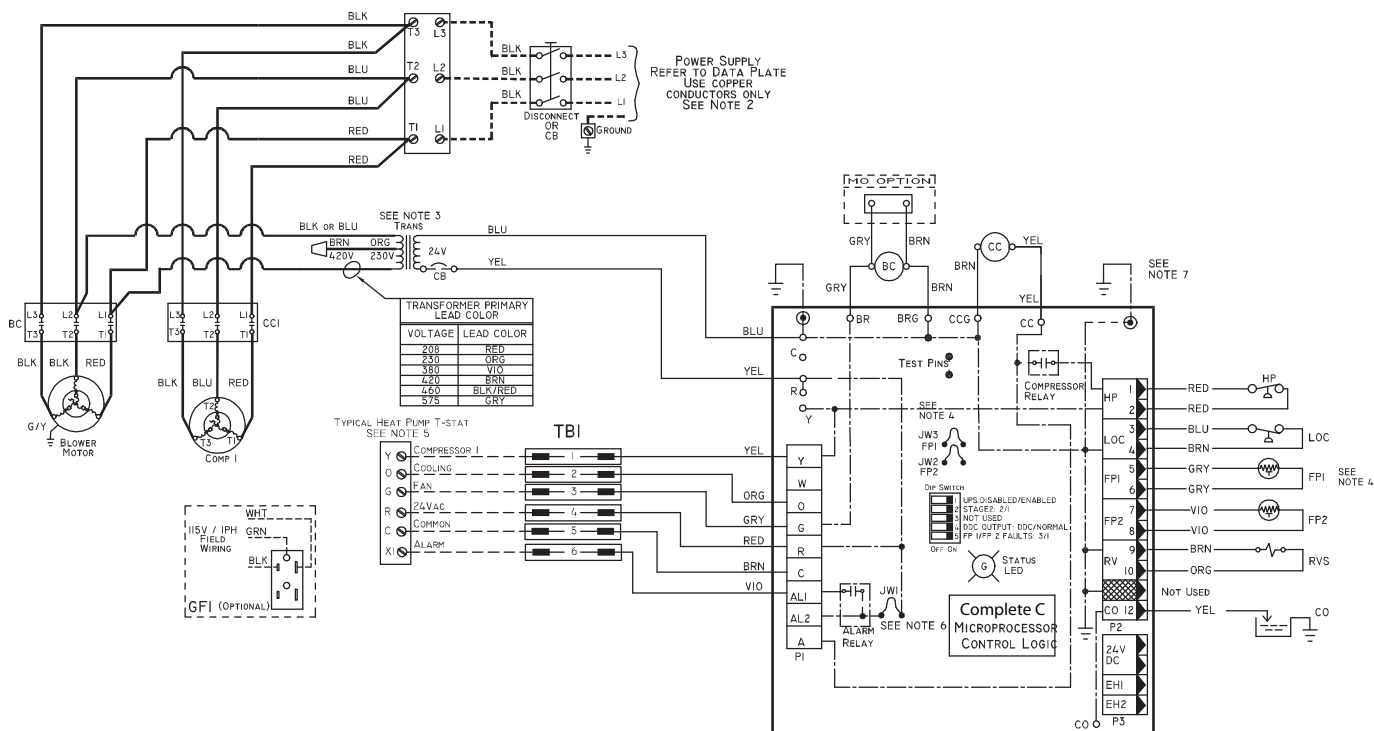
**LEGEND**

**bhp** — Brake Horsepower  
**ESP** — External Static Pressure

**NOTES:**

1. A = Standard RPM/Standard Motor, B = Low RPM/Standard Motor, C = High RPM/Standard Motor, D = Standard RPM/ Large Motor, E = High RPM/Large Motor

2. Unit shipped with standard drive package with drive sheave 2.5 turns open unless otherwise requested. Field adjustment may be required for specified CFM.
3. ISO/AHRI rating point with standard drive package and drive sheave open 3.0 turns at .30 ESP.
4. Performance data does not include drive losses and is based on sea level conditions.
5. All airflow is rated at lowest voltage if unit is dual rated, i.e., rated at 208 volts for 208-230 volt units.



#### LEGEND

- BC — Blower Contactor
- CB — Circuit Breaker
- CC — Compressor Contactor
- CO — Sensor, Condensate Overflow
- ECR — Enthalpy Control Relay
- FP1 — Sensor, Water Coil Freeze Protection
- FP2 — Sensor, Air Coil Freeze Protection
- GFI — Ground Fault Interrupter
- HP — High-Pressure Switch
- JW3 — Clippable Field Selection Jumper
- LAR — Low Ambient Relay
- LOC — Loss of Charge Pressure Switch
- MAS — Mixed Air Sensor
- OAT — Outdoor Air Thermostat
- PDB — Power Distribution Block
- RVS — Reversing Valve Solenoid
- TB — Terminal Block
- TRANS — Transformer
- Factory Line Voltage Wiring
- Factory Low Voltage Wiring

- Field Line Voltage Wiring
- Field Low Voltage Wiring
- Printed Circuit Trace
- Optional Wiring
- Relay/Contactor Coil
- Thermistor
- Condensate Pan
- Circuit Breaker

- ⊥ Ground
- Solenoid Coil
- Relay Contacts - N.O.
- Relay Contacts - N.C.
- Temperature Switch
- Switch - Low Pressure
- Switch - High Pressure
- Wire Nut

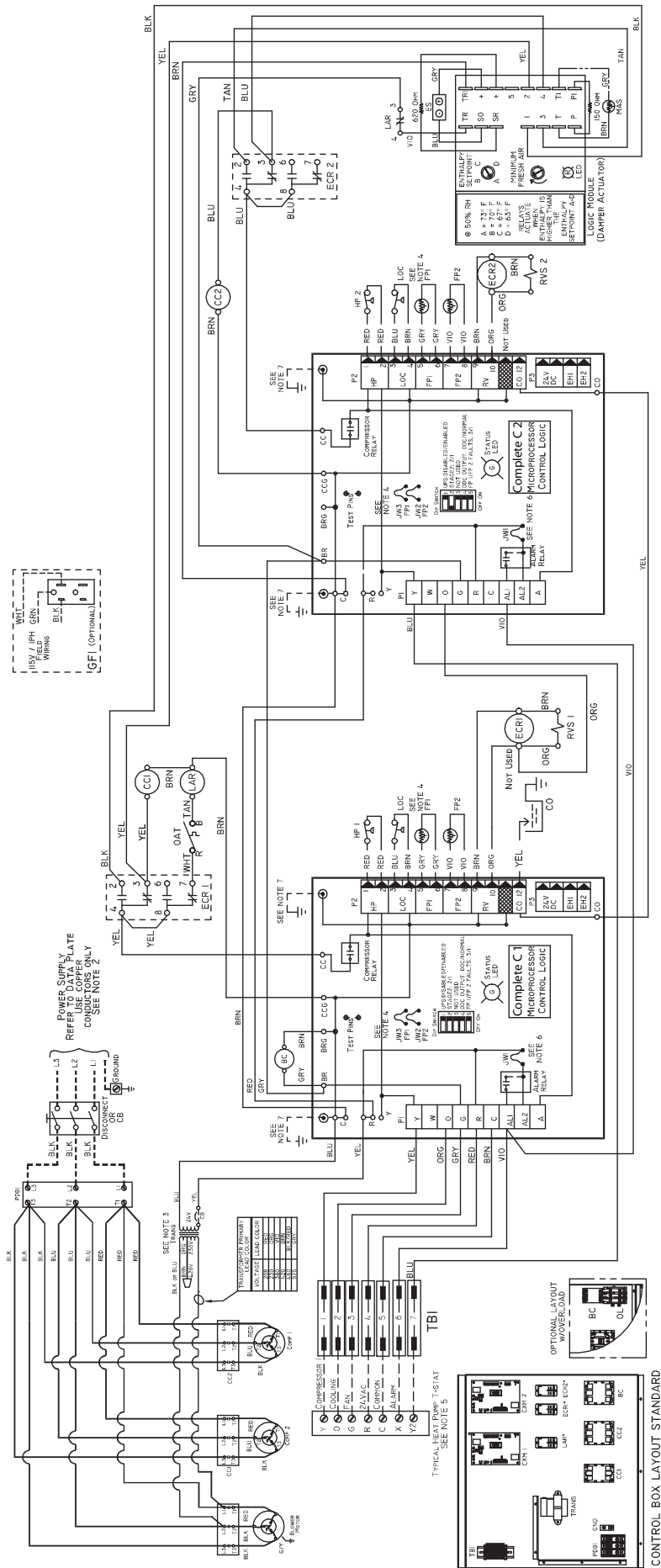
#### NOTES:

1. Compressor and blower motor thermally protected internally.
2. All wiring to the unit must comply with NEC (National Electrical Code) and local codes.
3. 208/230-v transformers will be connected for 208-v operation. For 230-v operation, disconnect RED lead at L1, and attach ORG lead to L1. Close open end of RED lead.
4. FPI thermistor provides freeze protection for WATER. When using ANTIFREEZE solutions, cut JW3 jumper.

5. Typical heat pump thermostat wiring shown. Refer to thermostat installation instructions for wiring to the unit. Thermostat wiring must be "Class 1" and voltage rating equal to or greater than unit supply voltage.
6. Factory cut JW1 jumper and dry contact will be available between AL1 and AL2.
7. Transformer secondary ground via Complete C board standoffs and screws to control box. (Ground available from top two standoffs as shown.)

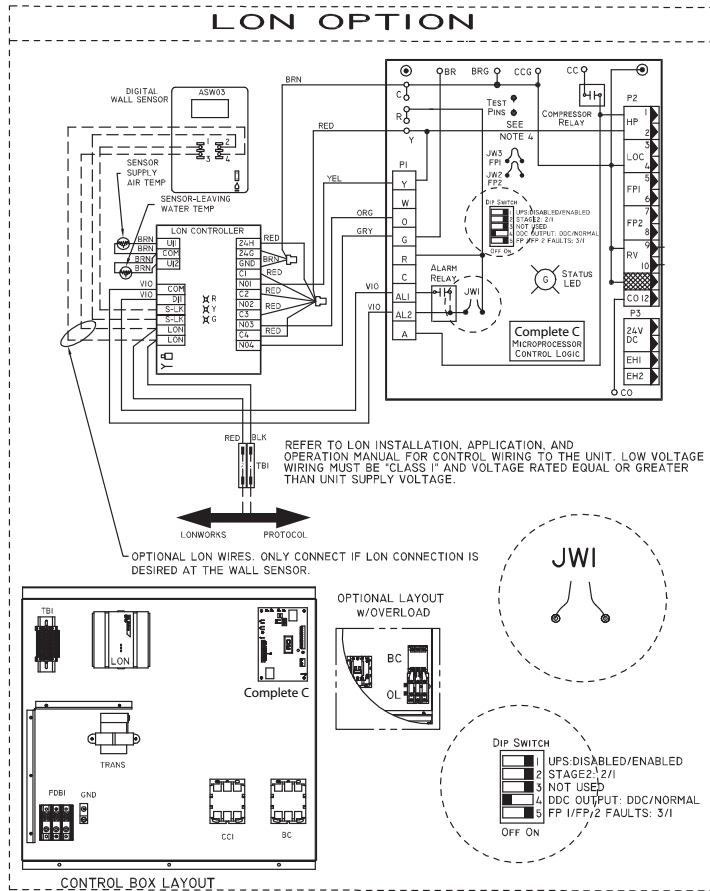
**Fig. 6 — 50RTP03-06 Units — Typical Control Wiring with Complete C Control**



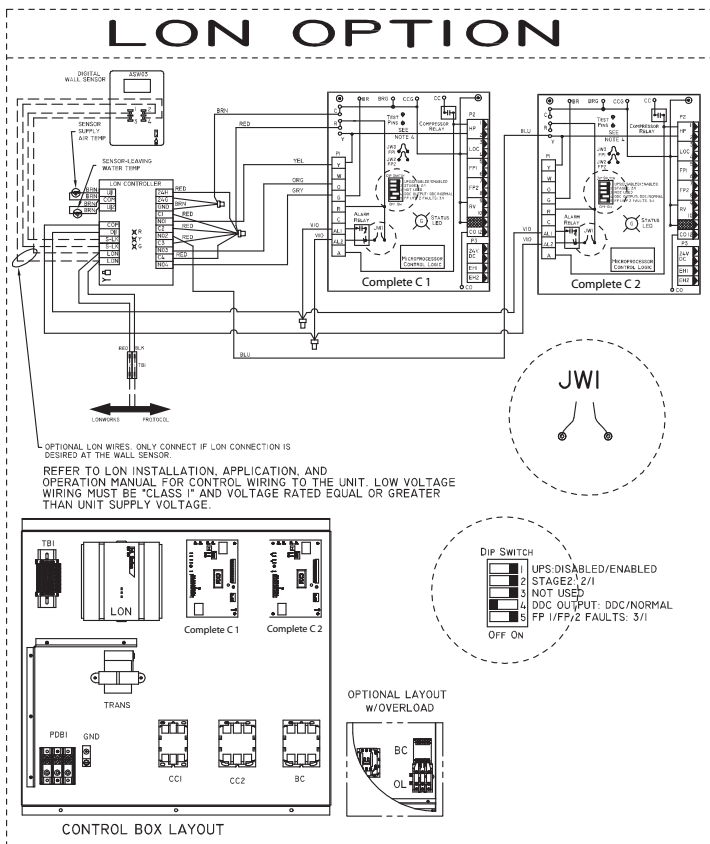


See legend and notes on page 24.

Fig. 7 — 50RTP08-20 Units — Typical Control Wiring with Complete C Controls and Optional Economizer

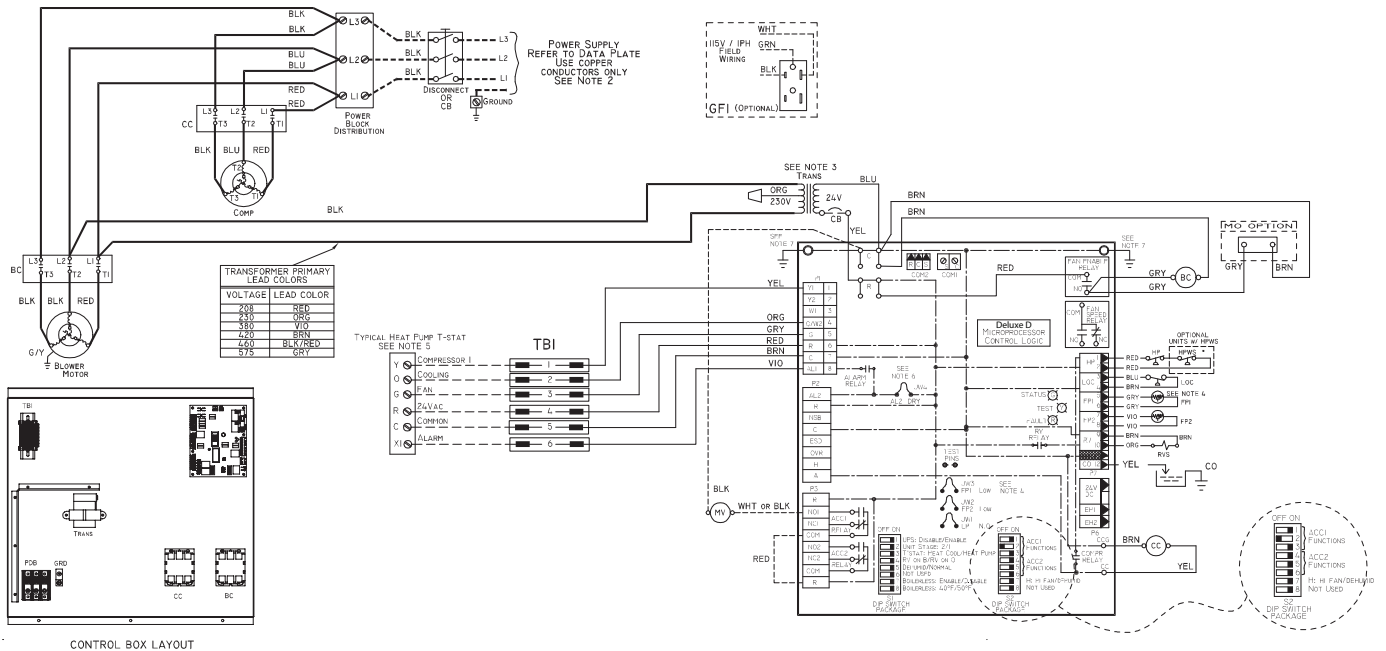


### 50RTP03-06 UNITS



### 50RTP08-20 UNITS

**Fig. 8 — Typical Control Wiring with Complete C and LON Controller**



CONTROL BOX LAYOUT

LEGEND

- BC — Blower Contactor
- CB — Circuit Breaker
- CC — Compressor Contactor
- CO — Sensor, Condensate Overflow
- ECR — Enthalpy Control Relay
- FP1 — Sensor, Water Coil Freeze Protection
- FP2 — Sensor, Air Coil Freeze Protection
- GFI — Ground Fault Interrupter
- HP — High-Pressure Switch
- HPWR — High Pressure Water Relay
- HPWS — High Pressure Water Switch
- JW3 — Clippable Field Selection Jumper
- LAR — Low Ambient Relay
- LOC — Loss of Charge Pressure Switch
- MAR — Mixed Air Relay
- MO — Motorized Outside Air Damper
- MV — Motorized Valve
- OAT — Outdoor Air Thermostat
- PDB — Power Distribution Block
- RVS — Reversing Valve Solenoid
- TRANS — Transformer
- Factory Line Voltage Wiring
- Factory Low Voltage Wiring

- Field Line Voltage Wiring
- Field Low Voltage Wiring
- . - - Printed Circuit Trace
- . . - Optional Wiring
- Relay/Contactor Coil
- Thermistor
- Condensate Pan
- Circuit Breaker

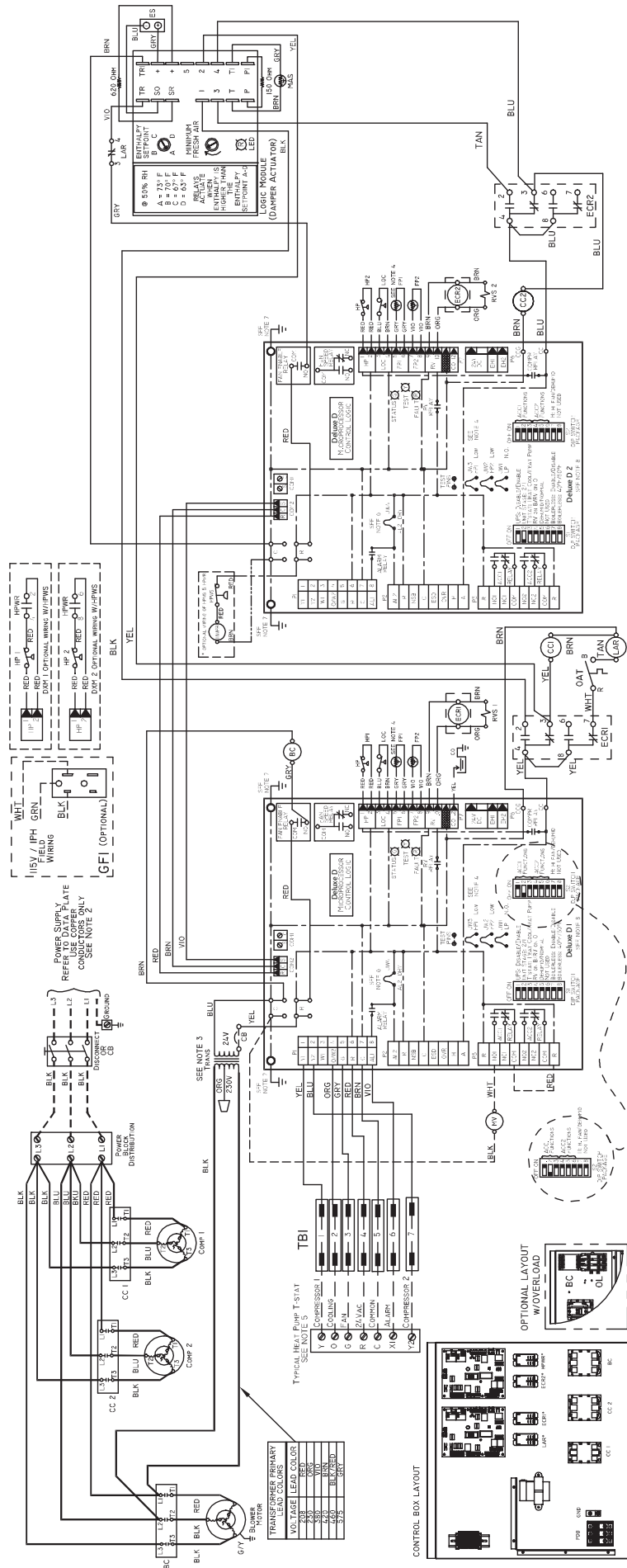
- ⊥ Ground
- Solenoid Coil
- Relay Contacts - N.O.
- Relay Contacts - N.C.
- Temperature Switch
- Switch - Low Pressure
- Switch - High Pressure
- Wire Nut

NOTES:

1. Compressor and blower motor thermally protected internally.
2. All wiring to the unit must comply with NEC (National Electrical Code) and local codes.
3. 208/230-v transformers will be connected for 208-v operation. For 230-v operation, disconnect RED lead at L1, and attach ORG lead to L1. Close open end of RED lead.
4. FPI thermistor provides freeze protection for WATER. When using ANTIFREEZE solutions, cut JW3 jumper.
5. Typical heat pump thermostat wiring shown. Refer to thermostat installation instructions for wiring to the unit. Thermostat wiring

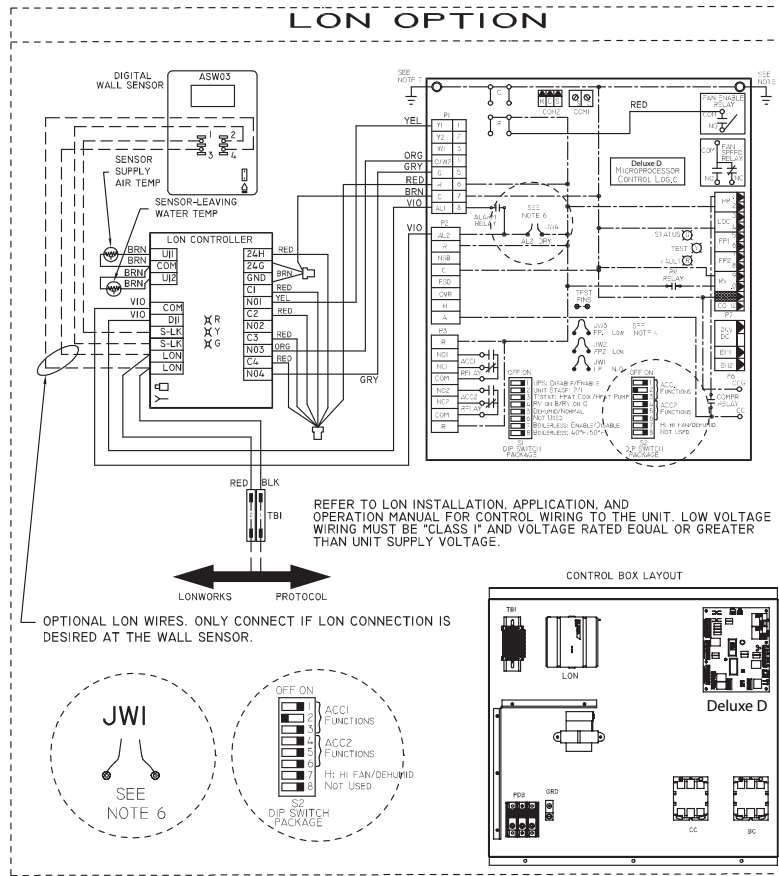
6. Factory cut JW1 jumper and dry contact will be available between AL1 and AL2.
7. Transformer secondary ground via Complete C board standoffs and screws to control box. (Ground available from top two stand-offs as shown.)
8. Suffix 1 designates association with lead compressor. Suffix 2 designates association with lag compressor.
9. For water valve option, DIP switch 2.1 ON, 2.2 OFF, 2.3 ON.

Fig. 9 — 50RTP03-06 Units — Typical Control Wiring with Deluxe D Controls

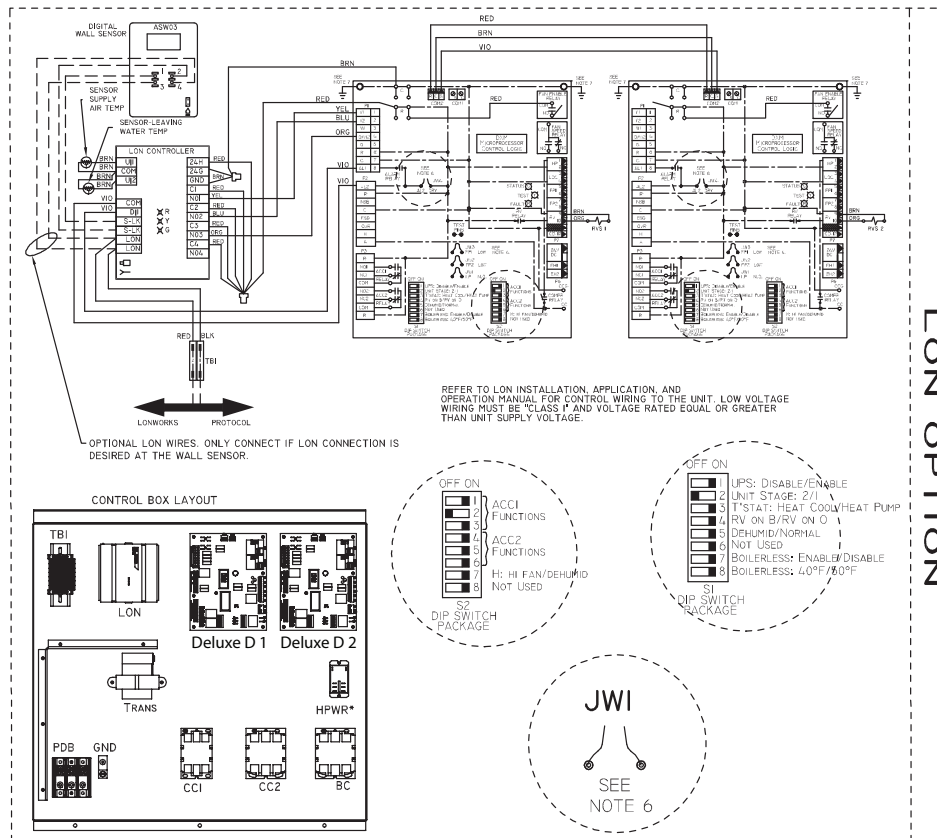


See legend and notes on page 27.

Fig. 10 — 50RTP08-20 Units — Typical Control Wiring with Deluxe D Controls and Optional Economizer

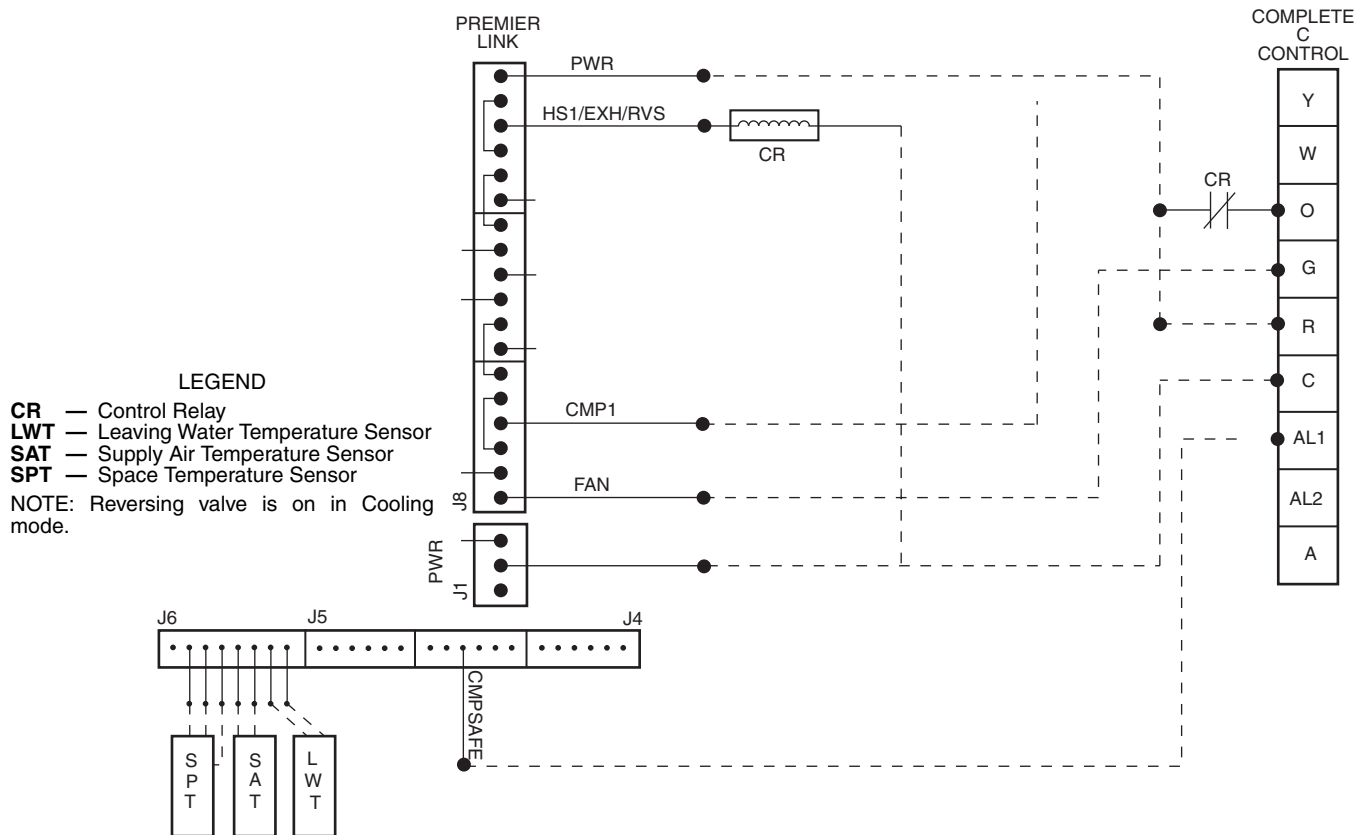


### SIZES 03-06

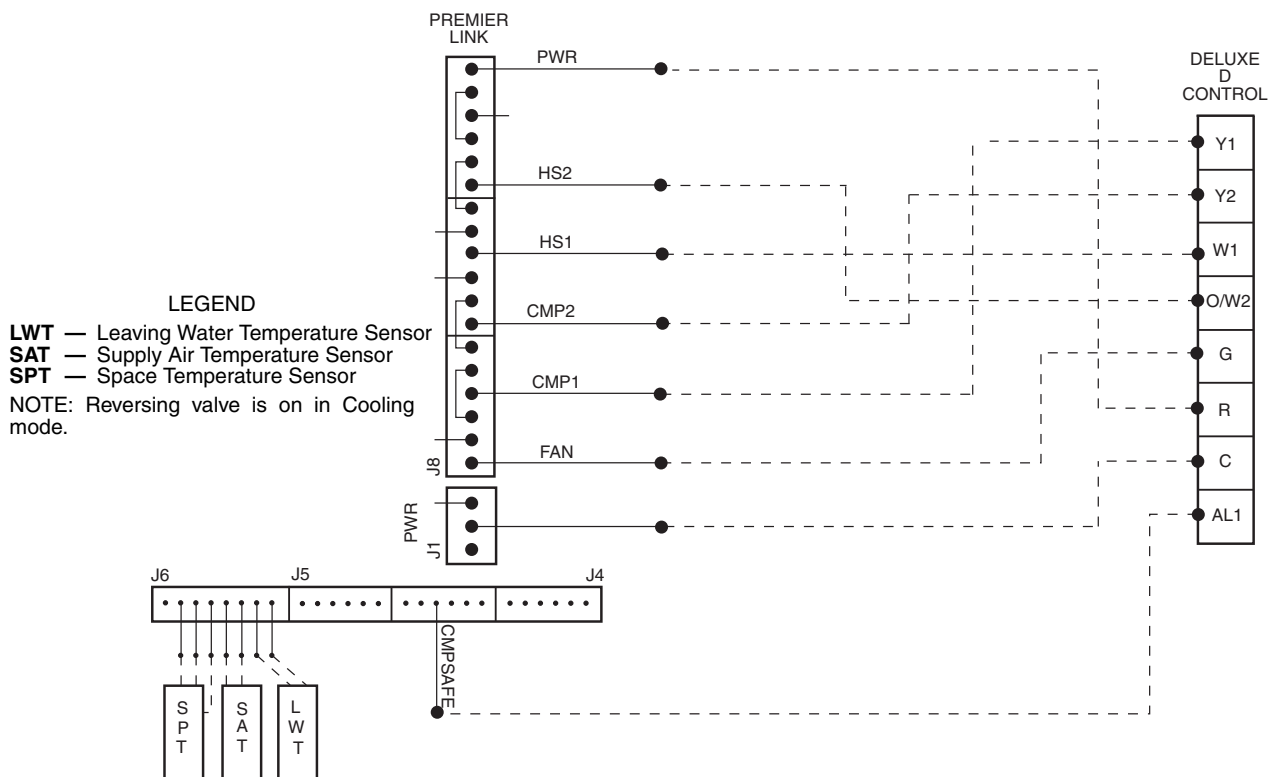


### SIZES 08-20

**Fig. 11 — Typical Control Wiring with Deluxe D and LON Controller**



**Fig. 12 — Premierlink™ Controller Applications Wiring with Complete C Control**



**Fig. 13 — Premierlink™ Controller Applications Wiring with Deluxe D Control**

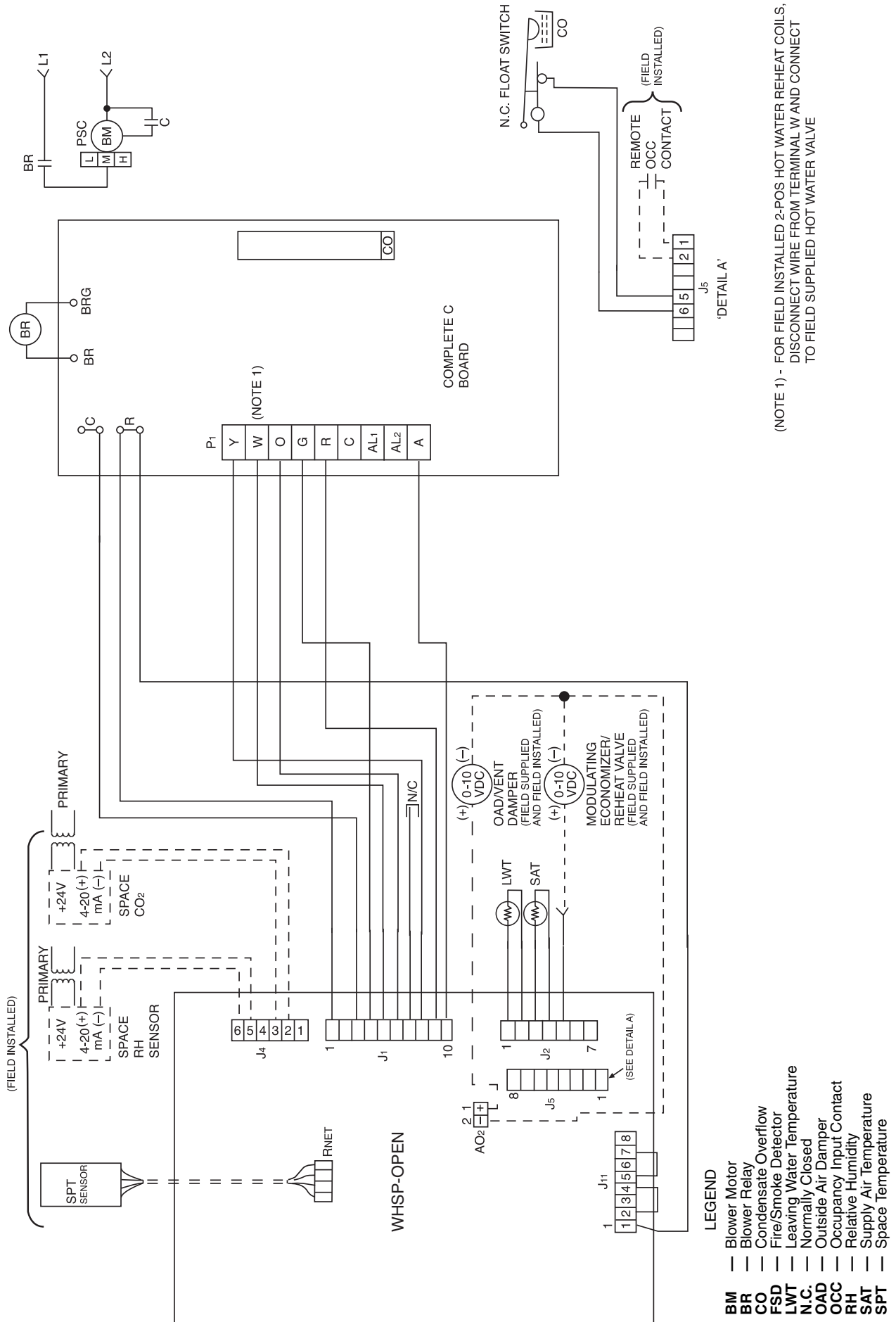
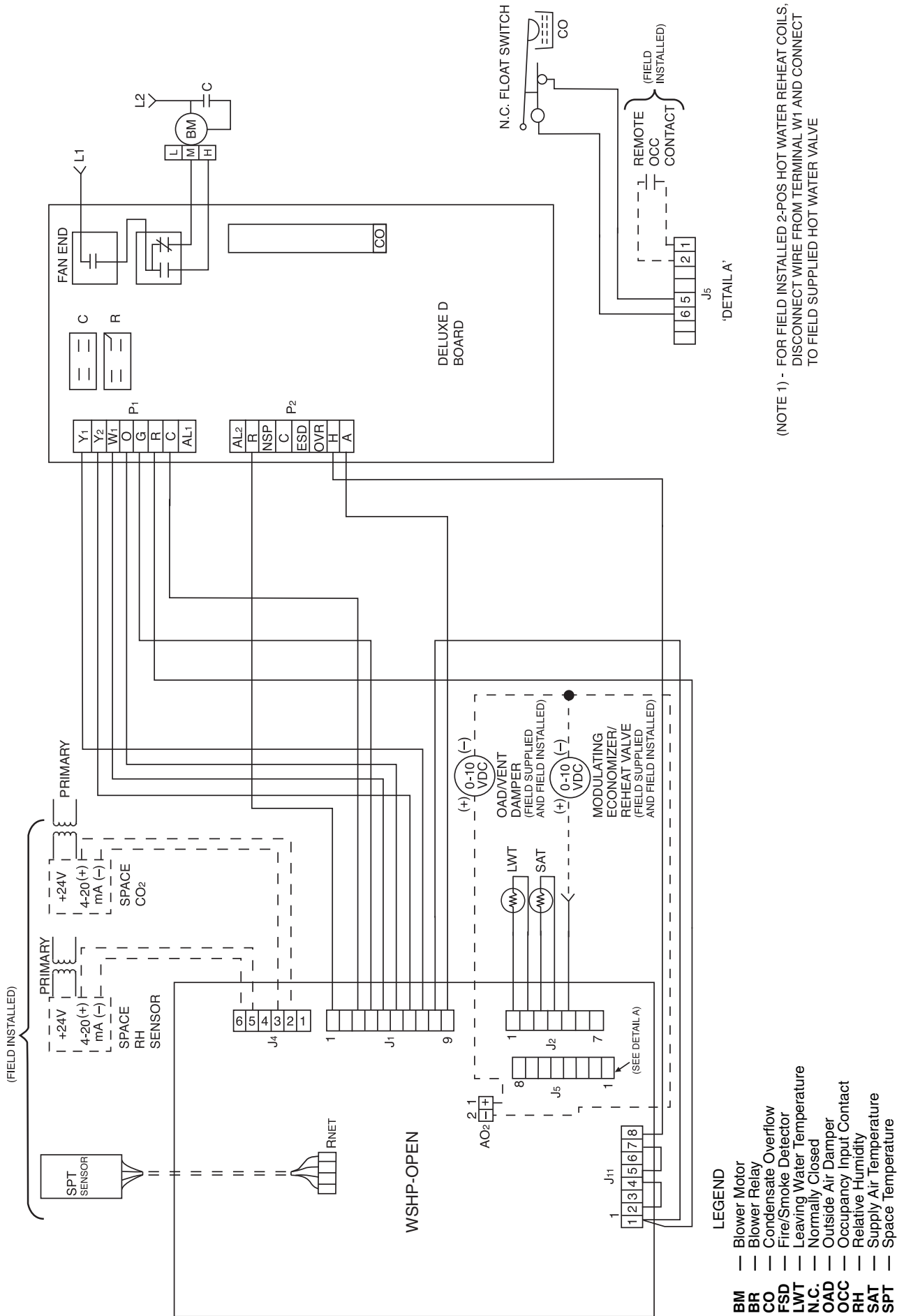


Fig. 14 — Units with Complete C and WSHP Open Multiple Protocol Controls



**Fig. 15 — Units with Deluxe D and WSHP Open Multiple Protocol Controls**





LEGEND

- AI Analog Input
- AO Analog Output
- BI Binary Input
- BO Binary Output
- SPT Space Temperature
- Field Wiring

NOTES:

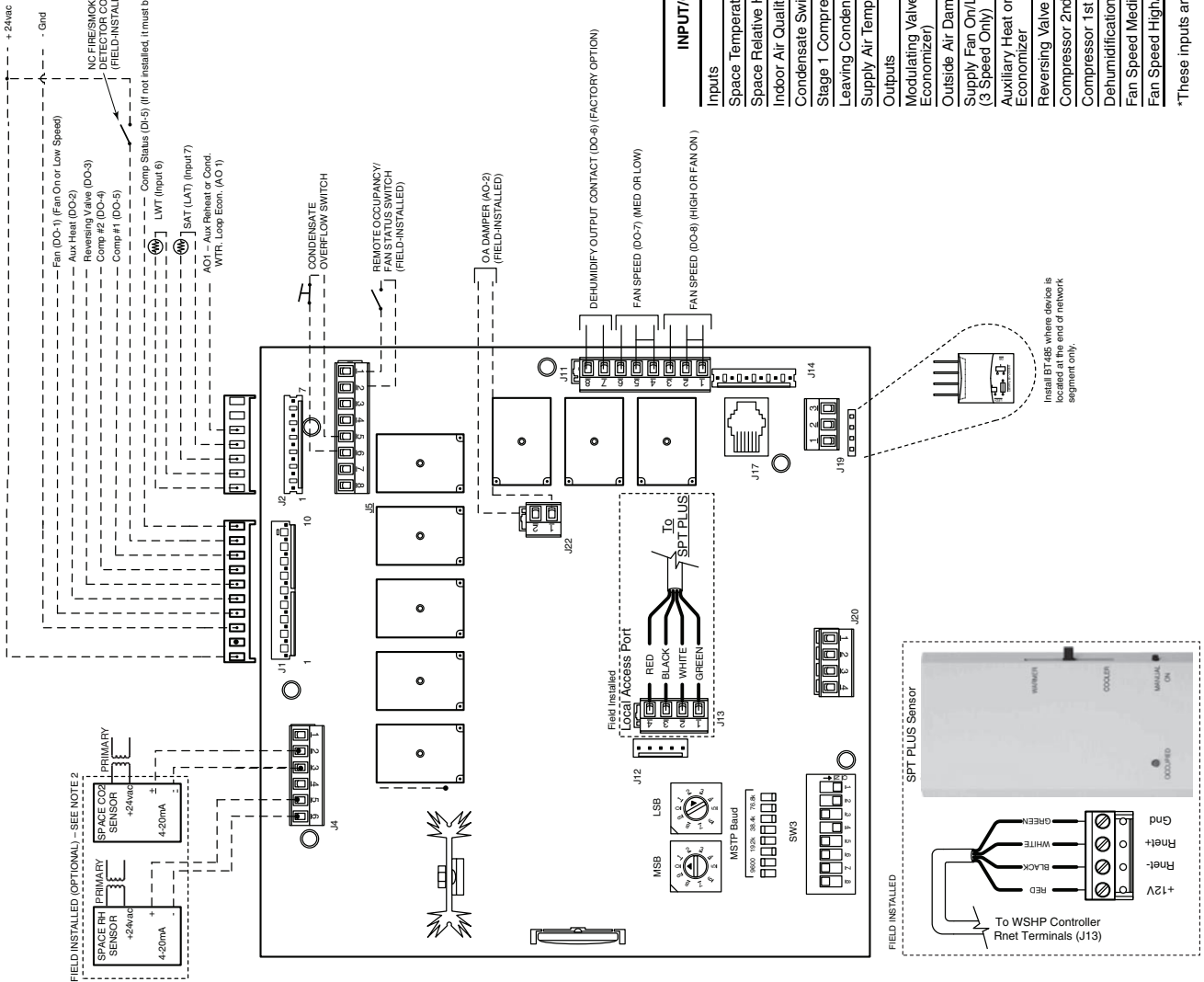
1. Mount the water source heat pump controller in the equipment controls enclosure with at least two no. 6 x 1 in. self-tapping screws. Allow adequate clearance for wiring.
2. Verify sensor power and wiring requirements prior to making any terminations. Sensors requiring a separate isolated 24 vac power source will not utilize WSHP terminals J4-1, or 4.

WSHP Open Inputs and Outputs Table

INPUT/OUTPUT TYPE	PART NUMBERS	TYPE OF I/O	CONNECTION PIN NUMBERS	CHANNEL DESIGNATION
<b>Inputs</b>				
Space Temperature Sensor	SPS, SPPL, SPP	Communicating	J13, 1 - 4	Local Access Port
Space Relative Humidity	33ZCSENSRH-01	AI (4 - 20mA)	J4, 5 and 6	Analog Input 1
Indoor Air Quality	33ZCSENSCO2	AI (4 - 20mA)	J4, 2 and 3	Analog Input 2
Condensate Switch	N/A	BI (Dry Contacts)	J1, 2	Binary Input 3
Stage 1 Compressor Status	N/A	BI (Dry Contacts)	J1, 10	Binary Input 5
Leaving Condenser Water Temperature	10K Type II	AI (10K Thermistor)	J2, 1 and 2	Analog Input 6
Supply Air Temperature	33ZCSENSAT	AI (10K Thermistor)	J2, 3 and 4	Analog Input 7
<b>Outputs</b>				
Modulating Valve (Auxiliary Heat/Water Economizer)	N/A	AO (0-10Vdc/2 - 10Vdc)	J2 4 and 5*	Analog Output 1
Outside Air Damper	N/A	AO (0-10Vdc/2 - 10Vdc)	J22 1 and 2*	Analog Output 2
Supply Fan On/Off Speed (3-Speed Only)	N/A	BO Relay (24VAC, 1A)	J1, 4*	Binary Output 1 (G)
Auxiliary Heat or 2-Position Water Loop Economizer	N/A	BO Relay (24VAC, 1A)	J1, 5*	Binary Output 2
Reversing Valve (B or O Operation)	N/A	BO Relay (24VAC, 1A)	J1, 6*	Binary Output 3 (RV)
Compressor 2nd Stage	N/A	BO Relay (24VAC, 1A)	J1, 7	Binary Output 4 (Y2)
Compressor 1st Stage	N/A	BO Relay (24VAC, 1A)	J1, 8	Binary Output 5 (Y1)
Dehumidification Relay	N/A	BO Relay (24VAC, 1A)	J11, 7 and 8 (NO)	Binary Output 6
Fan Speed Medium/Low (3 Speed Only)	N/A	BO Relay (24VAC, 1A)	J11, 5 and 6 (NO)*	Binary Output 7
Fan Speed High/Low (3 Speed Only)	N/A	BO Relay (24VAC, 1A)	J11, 2 and 3 (NO)*	Binary Output 8

\*These inputs are configurable.

Fig. 16 — WSHP Open Control



## Step 8 — Connect Low Voltage Wiring

**THERMOSTAT CONNECTIONS** — The thermostat should be wired directly to the Aquazone™ control board. See Fig. 17-19.

**WATER FREEZE PROTECTION** — The Aquazone control allows the field selection of source fluid freeze protection points through jumpers. The factory setting of jumper JW3 (FP1) is set for water at 30 F. In earth loop applications, jumper JW3 should be clipped to change the setting to 13 F when using antifreeze in colder earth loop applications. See Fig. 20.

**AIR COIL FREEZE PROTECTION** — The air coil freeze protection jumper JW2 (FP2) is factory set for 30 F and should not need adjusting, unless using anti-freeze.

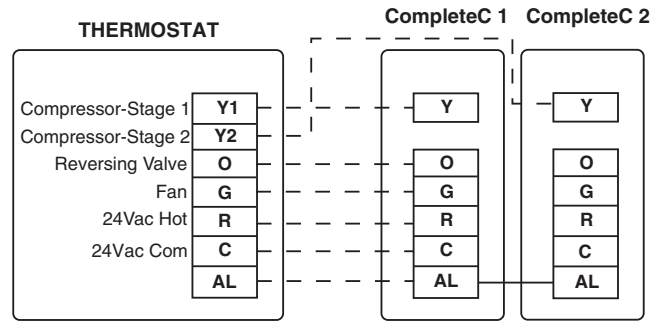
**ACCESSORY CONNECTIONS** — Terminal labeled A on the control is provided to control accessory devices such as water valves, electronic air cleaners, humidifiers, etc. This signal operates with the compressor terminal. See Fig. 21. Refer to the specific unit wiring schematic for details.

**NOTE:** The A terminal should *only* be used with 24 volt signals — not line voltage signals.

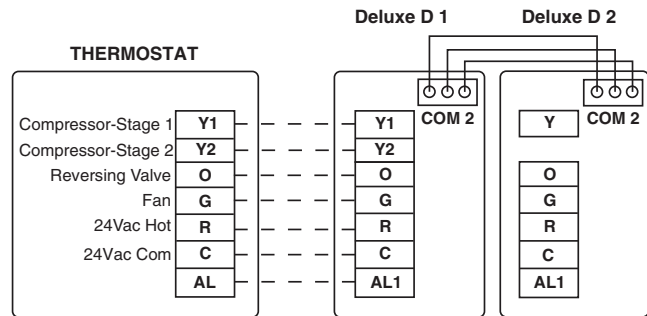
**WATER SOLENOID VALVES** — Water solenoid valves may be used on primary secondary pump and ground water installations. A typical well water control valve wiring which can limit waste water in a lockout condition is shown in Fig. 21. A slow closing valve may be required to prevent water hammer. When using a slow closing valve, special wiring conditions need to be considered. The valve takes approximately 60 seconds to open (very little water will flow before 45 seconds) and it activates the compressor only after the valve is completely opened by closing its end switch. When wired as shown, the valve will have the following operating characteristics:

1. Remain open during a lockout.
2. Draw approximately 25 to 35 VA through the “Y” signal of the thermostat.

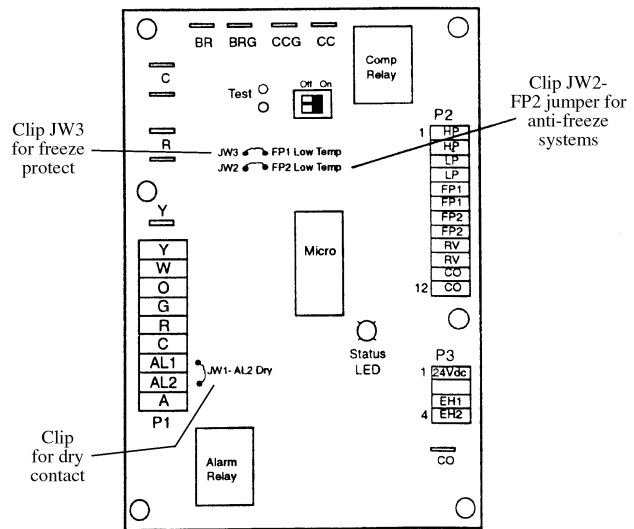
**IMPORTANT:** This can overheat the anticipators of electromechanical thermostats. Only use relay based electronic thermostats.



**Fig. 18 — Thermostat Wiring to Complete C Board**

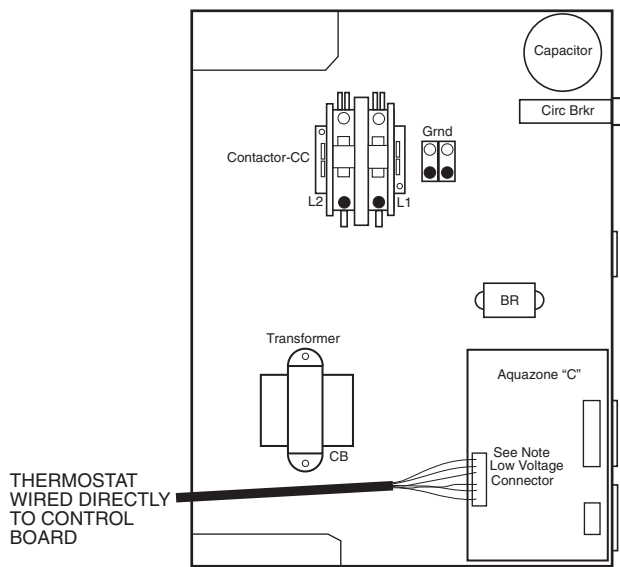


**Fig. 19 — Thermostat Wiring to Deluxe D Board**



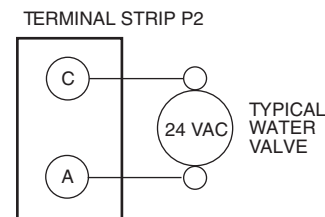
**AQUAZONE CONTROL (C Control Shown)**

**Fig. 20 — Typical Aquazone Control Board Jumper Locations**



**NOTE:** Low voltage connector may be removed for easy installation.

**Fig. 17 — Low Voltage Field Wiring**



**Fig. 21 — Typical D Control Accessory Wiring**

## PRE-START-UP

**System Checkout** — When the installation is complete and the system is cleaned and flushed, follow the System Checkout procedure outlined below.

1. **Voltage:** Ensure that the voltage is within the utilization range specifications of the unit compressor and fan motor.
2. **System Water Temperature:** Ensure that the system water temperature is within an acceptable range to facilitate start-up. (When conducting this check, also verify proper heating and cooling set points.)
3. **System Water pH:** Verify system water acidity (pH = 7.5 or 8.5). Proper pH promotes the longevity of hoses and heat exchangers.
4. **System Flushing:** Properly clean and flush the system periodically. Ensure that all supply and return hoses are connected end-to-end to facilitate system flushing and prevent fouling of the heat exchanger by system water. Water used in the system must be potable and should not contain dirt, piping slag, and chemical cleaning agents.
5. **Closed-Type Cooling Tower or Open Tower with Heat Exchanger:** Check equipment for proper temperature set points and operation.
6. **Verify Balanced Water Flow Rate to Heat Pump.**
7. **Standby Pump:** Verify that the standby pump is properly installed and in operating condition.
8. **Access Panels:** Assure that all access panels in the filter and fan section are securely closed.
9. **Air Dampers:** Assure that all air dampers are properly set.
10. **System Controls:** To ensure that no catastrophic system failures occur, verify that system controls are functioning and that the sequencing is correct.
11. **Freeze Protection for Water System:** Verify that freeze protection is provided for the building loop water system when outdoor design conditions require it. Inadequate freeze protection can lead to expensive tower and system piping repairs.
12. **System Water Loop:** Verify that all air is bled from the system. Air in the system impedes unit operation and causes corrosion in the system piping.
13. **Unit Filters:** To avoid system damage, check that the unit filter is clean.
14. **Unit Fans:** Manually rotate fans to assure free rotation. Ensure that fans are properly secured to the fan shaft. Do not oil fan motors on start-up since they are lubricated at the factory.
15. **System Control Center:** Examine the system control and alarm panel for proper installation and operation to ensure control of the temperature set-points for operation of the system's heat rejector and boiler (when used).
16. **Miscellaneous:** Note any questionable aspects of the installation.
17. **Air Coil:** To obtain maximum performance, the air coil should be cleaned before starting the unit. A ten percent solution of dishwasher detergent and water is recommended for both sides of the coil. Rinse thoroughly with water.

## FIELD SELECTABLE INPUTS

Jumpers and DIP (dual in-line package) switches on the control board are used to customize unit operation and can be configured in the field.

**IMPORTANT:** Jumpers and DIP switches should only be clipped when power to control board has been turned off.

### Complete C Control Jumper Settings (See Fig. 6 and 7)

**WATER COIL FREEZE PROTECTION (FP1) LIMIT SETTING** — Select jumper 3, (JW3-FP1 Low Temp) to choose FP1 limit of 10 F or 30 F. To select 30 F as the limit, DO NOT clip the jumper. To select 10 F as the limit, clip the jumper.

**AIR COIL FREEZE PROTECTION (FP2) LIMIT SETTING** — Select jumper 2 (JW2-FP2 Low Temp) to choose FP2 limit of 10 F or 30 F. To select 30 F as the limit, DO NOT clip the jumper. To select 10 F as the limit, clip the jumper.

**ALARM RELAY SETTING** — Select jumper 1 (JW1-AL2 Dry) for connecting alarm relay terminal (AL2) to 24 vac (R) or to remain as a dry contact (no connection). To connect AL2 to R, do not clip the jumper. To set as dry contact, clip the jumper.

**Complete C Control DIP Switches** — The Complete C control has 1 DIP switch block with two switches. See Fig. 6 and 7.

**PERFORMANCE MONITOR (PM)** — DIP switch 1 will enable or disable this feature. To enable the PM, set the switch to ON. To disable the PM, set the switch to OFF.

**STAGE 2** — DIP switch 2 will enable or disable compressor delay. Set DIP switch to OFF for stage 2 in which the compressor will have a 3-second delay before energizing.

**NOTE:** The alarm relay will not cycle during Test mode if switch is set to OFF, stage 2.

### Deluxe D Control Jumper Settings (See Fig. 9 and 10)

**WATER COIL FREEZE PROTECTION (FP1) LIMIT SETTING** — Select jumper 3, (JW3-FP1 Low Temp) to choose FP1 limit of 10 F or 30 F. To select 30 F as the limit, DO NOT clip the jumper. To select 10 F as the limit, clip the jumper.

**AIR COIL FREEZE PROTECTION (FP2) LIMIT SETTING** — Select jumper 2 (JW2-FP2 Low Temp) to choose FP2 limit of 10 F or 30 F. To select 30 F as the limit, DO NOT clip the jumper. To select 10 F as the limit (for anti-freeze systems), clip the jumper.

**ALARM RELAY SETTING** — Select jumper 4 (JW4-AL2 Dry) for connecting alarm relay terminal (AL2) to 24 vac (R) or to remain as a dry contact (no connection). To connect AL2 to R, do not clip the jumper. To set as dry contact, clip the jumper.

**LOW PRESSURE SETTING** — The Deluxe D control can be configured for Low Pressure Setting (LP). Select jumper 1 (JW1-LP Norm Open) for choosing between low pressure input normally opened or closed. To configure for normally closed operation, do not clip the jumper. To configure for normally open operation, clip the jumper.

**Deluxe D Control DIP Switches** — The Deluxe D control has 2 DIP switch blocks. Each DIP switch block has 8 switches and is labeled either S1 or S2 on the circuit board.

**DIP SWITCH BLOCK 1 (S1)** — This set of switches offers the following options for Deluxe D control configuration:

**Performance Monitor (PM)** — Set switch 1 to enable or disable performance monitor. To enable the PM, set the switch to ON. To disable the PM, set the switch to OFF.

**Compressor Relay Staging Operation** — Switch 2 will enable or disable compressor relay staging operation. The compressor relay can be set to turn on with stage 1 or stage 2 call

from the thermostat. This setting is used with dual stage units (units with 2 compressors and 2 Deluxe D controls) or in master/slave applications. In master/slave applications, each compressor and fan will stage according to its switch 2 setting. If switch is set to stage 2, the compressor will have a 3-second delay before energizing during stage 2 demand.

NOTE: If DIP switch is set for stage 2, the alarm relay will not cycle during Test mode.

**Heating/Cooling Thermostat Type** — Switch 3 provides selection of thermostat type. Heat pump or heat/cool thermostats can be selected. Select OFF for heat/cool thermostats. When in heat/cool mode, Y1 is used for cooling stage 1, Y2 is used for cooling stage 2, W1 is used for heating stage 1 and O/W2 is used for heating stage 2. Select ON for heat pump applications. In heat pump mode, Y1 used is for compressor stage 1, Y2 is used for compressor stage 2, W1 is used for heating stage 3 or emergency heat, and O/W2 is used for RV (heating or cooling) depending upon switch 4 setting.

**O/B Thermostat Type** — Switch 4 provides selection for heat pump O/B thermostats. O is cooling output. B is heating output. Select ON for heat pumps with O output. Select OFF for heat pumps with B output.

**Dehumidification Fan Mode** — Switch 5 provides selection of normal or dehumidification fan mode. Select OFF for dehumidification mode. The fan speed relay will remain OFF during cooling stage 2. Select ON for normal mode. The fan speed relay will turn on during cooling stage 2 in normal mode.

**Switch 6** — Not used.

**Boilerless Operation** — Switch 7 provides selection of boilerless operation and works in conjunction with switch 8. In boilerless operation mode, only the compressor is used for heating when FP1 is above the boilerless changeover temperature set by switch 8 below. Select ON for normal operation or select OFF for boilerless operation.

**Boilerless Changeover Temperature** — Switch 8 on S1 provides selection of boilerless changeover temperature set point. Select OFF for set point of 50 F or select ON for set point of 40 F.

If switch 8 is set for 50 F, then the compressor will be used for heating as long as the FP1 is above 50 F. The compressor will not be used for heating when the FP1 is below 50 F and the compressor will operate in emergency heat mode, staging on EH1 and EH2 to provide heat. If a thermal switch is being used instead of the FP1 thermistor, only the compressor will be used for heating mode when the FP1 terminals are closed. If the FP1 terminals are open, the compressor is not used and the control goes into emergency heat mode.

**DIP SWITCH BLOCK 2 (S2)** — This set of DIP switches is used to configure accessory relay options.

**Switches 1 to 3** — These DIP switches provide selection of Accessory 1 relay options. See Table 13 for DIP switch combinations.

**Switches 4 to 6** — These DIP switches provide selection of Accessory 2 relay options. See Table 14 for DIP switch combinations.

**Auto Dehumidification Mode or High Fan Mode** — Switch 7 provides selection of auto dehumidification fan mode or high fan mode. In auto dehumidification fan mode the fan speed relay will remain off during cooling stage 2 if terminal H is active. In high fan mode, the fan enable and fan speed relays will turn on when terminal H is active. Set the switch to ON for auto dehumidification fan mode or to OFF for high fan mode.

**Switch 8** — Not used.

**Table 13 — DIP Switch Block S2 — Accessory 1 Relay Options**

ACCESSORY 1 RELAY OPTIONS	DIP SWITCH POSITION		
	1	2	3
Cycle with Fan	On	On	On
Digital NSB	Off	On	On
Water Valve — Slow Opening	On	Off	On
OAD	On	On	Off

LEGEND

NSB — Night Setback  
OAD — Outside Air Damper

NOTE: All other DIP switch combinations are invalid.

**Table 14 — DIP Switch Block S2 — Accessory 2 Relay Options**

ACCESSORY 2 RELAY OPTIONS	DIP SWITCH POSITION		
	4	5	6
Cycle with Fan	On	On	On
Digital NSB	Off	On	On
Water Valve — Slow Opening	On	Off	On
OAD	On	On	Off

LEGEND

NSB — Night Setback  
OAD — Outside Air Damper

NOTE: All other switch combinations are invalid.

**Deluxe D Control Accessory Relay Configurations** — The following accessory relay settings are applicable for both Deluxe D controls only:

**CYCLE WITH FAN** — In this configuration, the relay will be ON any time the Fan Enable relay is on.

**CYCLE WITH COMPRESSOR** — In this configuration, the relay will be ON any time the Compressor relay is on.

**DIGITAL NIGHT SET BACK (NSB)** — In this configuration, the relay will be ON if the NSB input is connected to ground C.

NOTE: If there are no relays configured for digital NSB, then the NSB and OVR inputs are automatically configured for mechanical operation.

**MECHANICAL NIGHT SET BACK** — When NSB input is connected to ground C, all thermostat inputs are ignored. A thermostat set back heating call will then be connected to the OVR input. If OVR input becomes active, then the Deluxe D control will enter Night Low Limit (NLL) staged heating mode. The NLL staged heating mode will then provide heating during the NSB period.

**Water Valve (Slow Opening)** — If relay is configured for Water Valve (slow opening), the relay will start 60 seconds prior to starting compressor relay.

**Outside-Air Damper (OAD)** — If relay is configured for OAD, the relay will normally be ON any time the Fan Enable relay is energized. The relay will not start for 30 minutes following a return to normal mode from NSB, when NSB is no longer connected to ground C. After 30 minutes, the relay will start if the Fan Enable is set to ON.

**CAUTION**

To avoid equipment damage, DO NOT leave system filled in a building without heat during the winter unless antifreeze is added to system water. Condenser coils never fully drain by themselves and will freeze unless winterized with antifreeze.

## START-UP

Use the procedure outlined below to initiate proper unit start-up.

NOTE: This equipment is designed for indoor installation only.

### Operating Limits

**ENVIRONMENT** — This equipment is designed for outdoor installation ONLY. Extreme variations in temperature, humidity and corrosive water or air will adversely affect the unit performance, reliability and service life.

**POWER SUPPLY** — A voltage variation of  $\pm 10\%$  of nameplate utilization voltage is acceptable.

**UNIT STARTING CONDITIONS** — See Table 15 for unit starting conditions.

**Table 15 — Starting Conditions — 50RTP Units**

AIR LIMITS	COOLING	HEATING
Minimum Entering Air	40 F	40 F
Maximum Entering Air (db)	110 F	80 F
WATER LIMITS		
Minimum Entering Fluid	40 F	20 F
Maximum Entering Fluid	120 F	90 F

#### LEGEND

db — Dry Bulb

NOTE: These starting conditions are not normal or continuous operating conditions. It is assumed that such a start-up is for the purpose of bringing the building space up to occupancy temperature. See Table 16 for operating limits.

### WARNING

When the disconnect switch is closed, high voltage is present in some areas of the electrical panel. Exercise caution when working with the energized equipment.

1. Restore power to system.
2. Turn thermostat fan position to ON. Blower should start.
3. Balance airflow at registers.
4. Adjust all valves to the full open position and turn on the line power to all heat pump units.
5. Operate unit in the cooling cycle. Room temperature should be approximately 70 to 75 F dry bulb. Loop water temperature entering the heat pumps should be between 60 and 110 F.

NOTE: Three factors determine the operating limits of a unit: (1) entering air temperature, (2) water temperature and (3) ambient temperature. Whenever any of these factors are at a minimum or maximum level, the other two factors must be at a normal level to ensure proper unit operation. See Table 15.

**Table 16 — Operating Limits — 50RTP Units**

AIR LIMITS	COOLING	HEATING
Minimum Entering Air	60 F	50 F
Maximum Entering Air (db)	90 F	80 F
WATER LIMITS		
Minimum Entering Fluid	40 F	20 F
Maximum Entering Fluid	120 F	90 F

#### LEGEND

db — Dry Bulb

**Scroll Compressor Rotation** — It is important to be certain compressor is rotating in the proper direction. To determine whether or not compressor is rotating in the proper direction, perform the following procedure.

1. Connect service gages to suction and discharge pressure fittings.
2. Energize the compressor.
3. The suction pressure should drop and the discharge pressure should rise, as is normal on any start-up.

If the suction pressure does not drop and the discharge pressure does not rise to normal levels:

1. Turn off power to the unit. Install disconnect tag.
2. Reverse any two of the unit power leads.
3. Reapply power to the unit and verify pressures are correct.

The suction and discharge pressure levels should now move to their normal start-up levels.

When the compressor is rotating in the wrong direction, the unit makes an elevated level of noise and does not provide cooling.

After a few minutes of reverse operation, the scroll compressor internal overload protection will open, thus activating the unit lockout. This requires a manual reset. To reset, turn the thermostat on and then off.

NOTE: There is a 5-minute time delay before the compressor will start.

### Unit Start-Up Cooling Mode

1. Adjust the unit thermostat to the warmest position. Slowly reduce the thermostat position until the compressor activates.
2. Check for cool air delivery at unit grille a few minutes after the unit has begun to operate.
3. Verify that the compressor is on and that the water flow rate is correct by measuring pressure drop through the heat exchanger using P/T plugs. Check the elevation and cleanliness of the condensate lines; any dripping could be a sign of a blocked line. Be sure the condensate trap includes a water seal.
4. Check the temperature of both supply and discharge water. If temperature is within range, proceed. If temperature is outside the range, check the cooling refrigerant pressures.
5. Air temperature drop across the coil should be checked when compressor is operating. Air temperature drop should be between 15 and 25 F.

### Unit Start-Up Heating Mode

NOTE: Operate the unit in heating cycle after checking the cooling cycle. Allow five minutes between tests for the pressure or reversing valve to equalize.

1. Turn thermostat to lowest setting and set thermostat switch to HEAT position.
2. Slowly turn the thermostat to a higher temperature until the compressor activates.
3. Check for warm air delivery at the unit grille within a few minutes after the unit has begun to operate.
4. Check the temperature of both supply and discharge water. If temperature is within range, proceed. If temperature is outside the range, check the heating refrigerant pressures.
5. Once the unit has begun to run, check for warm air delivery at the unit grille.
6. Air temperature rise across the coil should be checked when compressor is operating. Air temperature rise should be between 20 and 30 F after 15 minutes at load.
7. Check for vibration, noise and water leaks.

## Unit Start-Up with WSHP Open Controls —

The WSHP Open is a multi-protocol (default BACnet\*) controller with extensive features, flexible options and powerful capabilities. The unit comes from the factory pre-programmed and needs minimal set up to function in a BAS (Building Automation System) system or provide additional capabilities to Carrier's WSHP product line. Most settings on the controller have factory defaults set for ease of installation. There are a few settings that must be configured in the field and several settings that can be adjusted if required by unique job conditions. Refer to Appendix A — WSHP Open Screen Configuration. In order to configure the unit, a BACview<sup>6</sup> display is required. See Fig. 22.

NOTE: If the WSHP Open control has lost its programming, all display pixels will be displayed on the SPT sensor. See the WSHP Third Party Integration Guide.

When the unit is OFF, the SPT sensor will indicate OFF. When power is applied, the SPT sensor will indicate temperature in the space at 78 F.

To start up a unit with WSHP Open controls:

1. To plug in the BACview<sup>6</sup> handheld display into a SPT sensor, point the two ears on the connector up and tilt the bottom of the plug toward you. Insert the plug up into the SPT sensor while pushing the bottom of the plug away from you.
2. BACview<sup>6</sup> should respond with "Establishing Connection." The Home screen will then appear on the display showing operating mode and space temperature. Press any button to continue.  
See Appendix A — WSHP Open Screen Configuration for the hierarchical structure of the WSHP Open controller. All functions of the controller can be set from the Home screen.
3. When the Login is requested, type 1111 and push the OK softkey. The Logout will then be displayed to indicate the password was accepted.
4. To set the Clock if it is not already displayed:
  - a. Select System Settings from the Home screen, then press Clockset.
  - b. Scroll to hour, minute and second using the arrow keys. Use the number keypad to set actual time.
  - c. Scroll to day, month and year using arrow keys. Use number keypad to set date.
5. To set Daylight Savings Time (DST):
  - a. Push the DST softkey. The display will indicate 02:00:060 which is equal to 2:00AM.

- b. To program the beginning and end dates, scroll down to the beginning month and press the enter key. The softkeys (INCR and DECR) will activate to increment the month in either direction, Jan, Feb, March, etc.
  - c. Use number keys to select the day of month and year.
  - d. Push the OK softkey to finalize the data.
6. To view configuration settings:
    - a. Select the Config softkey.
    - b. Select the Service Config softkey. Scroll through the factory settings by using the up and down arrow keys. See below for factory settings.  
Only the following settings will need to be checked.
      - # of Fan Speeds — This should be set to "1" for units with PSC motors and set to "3" for units with ECM motors.
      - Compressor Stages — This should be set to "1."
      - Factory Dehumidification Reheat Coil — This should be set to "none" unless the modulating hot water reheat option is supplied in the unit, then set to "installed."
      - The condenser water limit needs to be verified depending on design parameters and application, whether geothermal or boiler/tower.
  7. To view unit configuration settings:
    - a. Select the Unit Configuration softkey, then select Unit.
    - b. Scroll through the unit settings by using the up and down arrow keys. Unit settings include:
      - Fan Mode: Default Continuous
      - Fan Delay:
      - Minimum SAT Cooling: Default 50 F
      - Maximum SAT Heating: Default 110 F
      - Filter Service Alarm: Must be set from 0 to 9999 hr
  8. To set local schedules:
    - a. Select the Schedule softkey from the Configuration screen, then press enter.
    - b. Select Weekly, then press enter (7 schedules available).
    - c. Select day and press enter.
    - d. Press enter again and select ADD or DEL (DECR or INCR) set schedule.

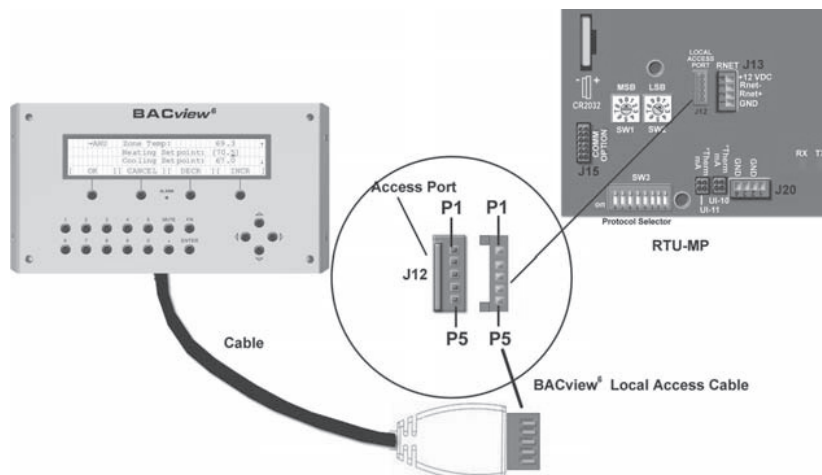


Fig. 22 — BACview<sup>6</sup> Display Interface

\*Sponsored by ASHRAE (American Society of Heating, Refrigerating, and Air Conditioning Engineers).

- e. Enter ON/OFF time, then press continue.
- f. Press OK to apply and save to a particular day of the week.
- g. Continue to add the same or different schedule specific days of the week.  
To add exceptions to the schedule:
  - i. Press Add softkey.
  - ii. Select exception type from following:
    - Date
    - Date Range
    - Week-N-Day
    - Calender Reference
9. Go back to Home Screen.
10. Remove BACview<sup>6</sup> cable from SPT sensor by reversing the process in Step 1.
11. Perform system test.

**Flow Regulation** — Flow regulation can be accomplished by two methods. Most water control valves have a flow adjustment built into the valve. By measuring the pressure drop through the unit heat exchanger, the flow rate can be determined. Adjust the water control valve until the flow of 1.5 to 2 gpm is achieved. Since the pressure constantly varies, two pressure gages may be needed in some applications.

An alternative method is to install a flow control device. These devices are typically an orifice of plastic material designed to allow a specified flow rate that are mounted on the outlet of the water control valve. Occasionally these valves produce a velocity noise that can be reduced by applying some back pressure. To accomplish this, slightly close the leaving isolation valve of the well water setup.

**⚠ WARNING**

Electrical shock can cause personal injury and death. Shut off all power to this equipment during installation. There may be more than one disconnect switch. Tag all disconnect locations to alert others not to restore power until flushing is completed.

**System Cleaning and Flushing** — Cleaning and flushing the unit is the single most important step to ensure proper start-up and continued efficient operation of the system. Follow the instructions below to properly clean and flush the system:

1. Verify that electrical power to the units is disconnected.
2. Install the system with the supply hose connected directly to the return riser valve. Use a single length of flexible hose.
3. Open all air vents. Fill the system with water. Do not allow system to overflow. Bleed all air from the system. Check the system for leaks and repair appropriately.
4. Verify that all strainers are in place. Start the pumps and systematically check each vent to ensure that all air is bled from the system.
5. Verify that makeup water is available. Adjust makeup water appropriately to replace the air which was bled from the system. Check and adjust the water/air level in the expansion tank.
6. Set the boiler (when used) to raise the loop temperature to approximately 85 F. Open a drain at the lowest point in the system. Adjust the makeup water replacement rate to equal the rate of bleed.
7. Refill the system and add trisodium phosphate in a proportion of approximately one pound per 150 gallons of water. Reset the boiler (when used) to raise the loop temperature to about 100 F. Circulate the solution for a

minimum of eight to 24 hours. At the end of this period, shut off the circulating pump and drain the solution. Repeat system cleaning if necessary.

**⚠ CAUTION**

To avoid possible damage to piping systems constructed of plastic piping, DO NOT allow loop temperature to exceed 115 F.

8. When the cleaning process is complete, remove the short-circuited hoses. Reconnect the hoses to the proper supply and return the connections to each of the rooftop units. Refill the system and bleed off all air.
9. Add antifreeze to the system in climates where ambient temperature falls below freezing, using the proportion of antifreeze shown in Table 17. The volume of antifreeze required will vary based on outdoor design temperature.
10. Test the system pH with litmus paper. The system water should be slightly alkaline (pH 7.5 to 8.5). Add chemicals as appropriate to maintain acidity levels.
11. When the system is successfully cleaned, flushed, refilled and bled, check the main system panels, safety cutouts, and alarms. Set the controls to properly maintain loop temperatures.

NOTE: Carrier strongly recommends all piping connections, both internal and external to the unit, be pressure tested by an appropriate method prior to any finishing of the interior space or before access to all connections is limited. Test pressure may not exceed the maximum allowable pressure for the unit and all components within the water system.

Carrier will not be responsible or liable for damages from water leaks due to inadequate or lack of a pressurized leak test, or damages caused by exceeding the maximum pressure rating during installation.

**⚠ CAUTION**

Do Not use “Stop-Leak” or any similar chemical agent in this system. Addition of these chemicals to the loop water will foul the system and will inhibit unit operation.

**Antifreeze** — In areas where entering loop temperatures drop below 40 F or where piping will be routed through areas subject to freezing, antifreeze is needed.

Alcohols and glycols are commonly used as antifreeze agents. Freeze protection should be maintained to 15 F below the lowest expected entering loop temperature. For example, if the lowest expected entering loop temperature is 30 F, the leaving loop temperature would be 22 to 25 F. Therefore, the freeze protection should be at 15 F (30 F – 15 F = 15 F).

**IMPORTANT:** All alcohols should be pre-mixed and pumped from a reservoir outside of the building or introduced under water level to prevent fumes.

Calculate the total volume of fluid in the piping system. Use the percentage by volume in Table 17 to determine the amount of antifreeze to use. Antifreeze concentration should be checked from a well mixed sample using a hydrometer to measure specific gravity.

**FREEZE PROTECTION SELECTION** — The 30 F FP1 factory setting (water) should be used to avoid freeze damage to the unit.

Once antifreeze is selected, the JW3 jumper (FP1) should be clipped on the control to select the low temperature (antifreeze 13 F) set point to avoid nuisance faults.

**Table 17 — Antifreeze Percentages by Volume**

ANTIFREEZE	MINIMUM TEMPERATURE FOR FREEZE PROTECTION (F)			
	0°	10	20	30
Methanol (%)	25	21	16	10
Propylene Glycol (%)	26	23	19	9
Ethylene Glycol (%)	24	20	16	12

**Cooling Tower/Boiler Systems** — These systems typically use a common loop maintained at 60 to 90 F. The use of a closed circuit evaporative cooling tower with a secondary heat exchanger between the tower and the water loop is recommended. If an open type cooling tower is used continuously, chemical treatment and filtering will be necessary.

**Ground Coupled, Closed Loop and Plateframe Heat Exchanger Well Systems** — These systems allow water temperatures from 30 to 110 F. The external loop field is divided up into 2 in. polyethylene supply and return lines. Each line has valves connected in such a way that upon system start-up, each line can be isolated for flushing using only the system pumps. Air separation should be located in the piping system prior to the fluid re-entering the loop field.

## OPERATION

**Power Up Mode** — The unit will not operate until all the inputs, terminals and safety controls are checked for normal operation.

NOTE: The compressor will have a 5-minute anti-short cycle upon power up.

### Units with Aquazone™ Complete C Control

STANDBY — Y and W terminals are not active in standby mode, however the O and G terminals may be active, depending on the application. The compressor will be off.

COOLING — Y and O terminals are active in Cooling mode. After power up, the first call to the compressor will initiate a 5 to 80 second random start delay and a 5-minute anti-short cycle protection time delay. After both delays are complete, the compressor is energized.

NOTE: On all subsequent compressor calls the random start delay is omitted.

HEATING STAGE 1 — Terminal Y is active in heating stage 1. After power up, the first call to the compressor will initiate a 5 to 80 second random start delay and a 5-minute anti-short cycle protection time delay. After both delays are complete, the compressor is energized.

NOTE: On all subsequent compressor calls the random start delay is omitted.

HEATING STAGE 2 — To enter Stage 2 mode, terminal W is active (Y is already active). Also, the G terminal must be active or the W terminal is disregarded. The compressor relay will remain on and EH1 is immediately turned on. EH2 will turn on after 10 minutes of continual stage 2 demand.

NOTE: EH2 will not turn on (or if on, will turn off) if FP1 temperature is greater than 45 F and FP2 is greater than 110 F.

EMERGENCY HEAT — In emergency heat mode, terminal W is active while terminal Y is not. Terminal G must be active or the W terminal is disregarded. EH1 is immediately turned on. EH2 will turn on after 5 minutes of continual emergency heat demand.

### Units with Aquazone Deluxe D Control

STANDBY/FAN ONLY — The compressor will be off. The Fan Enable, Fan Speed, and reversing valve (RV) relays will be on if inputs are present. If there is a Fan 1 demand, the Fan

Enable will immediately turn on. If there is a Fan 2 demand, the Fan Enable and Fan Speed will immediately turn on.

NOTE: DIP switch 5 on S1 does not have an effect upon Fan 1 and Fan 2 outputs.

HEATING STAGE 1 — In Heating Stage 1 mode, the Fan Enable and Compressor relays are turned on immediately. Once the demand is removed, the relays are turned off and the control reverts to Standby mode. If there is a master/slave or dual compressor application, all compressor relays and related functions will operate per their associated DIP switch 2 setting on S1.

HEATING STAGE 2 — In Heating Stage 2 mode, the Fan Enable and Compressor relays remain on. The Fan Speed relay is turned on immediately and turned off immediately once the demand is removed. The control reverts to Heating Stage 1 mode. If there is a master/slave or dual compressor application, all compressor relays and related functions will operate per their associated DIP switch 2 setting on S1.

HEATING STAGE 3 — In Heating Stage 3 mode, the Fan Enable, Fan Speed and Compressor relays remain on. The EH1 output is turned on immediately. With continuing Heat Stage 3 demand, EH2 will turn on after 10 minutes. EH1 and EH2 are turned off immediately when the Heating Stage 3 demand is removed. The control reverts to Heating Stage 2 mode.

Output EH2 will be off if FP1 is greater than 45 F AND FP2 (when shorted) is greater than 110 F during Heating Stage 3 mode. This condition will have a 30-second recognition time. Also, during Heating Stage 3 mode, EH1, EH2, Fan Enable, and Fan Speed will be ON if G input is not active.

EMERGENCY HEAT — In Emergency Heat mode, the Fan Enable and Fan Speed relays are turned on. The EH1 output is turned on immediately. With continuing Emergency Heat demand, EH2 will turn on after 5 minutes. Fan Enable and Fan Speed relays are turned off after a 60-second delay. The control reverts to Standby mode.

Output EH1, EH2, Fan Enable, and Fan Speed will be ON if the G input is not active during Emergency Heat mode.

COOLING STAGE 1 — In Cooling Stage 1 mode, the Fan Enable, compressor and RV relays are turned on immediately. If configured as stage 2 (DIP switch set to OFF) then the compressor and fan will not turn on until there is a stage 2 demand. The fan Enable and compressor relays are turned off immediately when the Cooling Stage 1 demand is removed. The control reverts to Standby mode. The RV relay remains on until there is a heating demand. If there is a master/slave or dual compressor application, all compressor relays and related functions will track with their associated DIP switch 2 on S1.

COOLING STAGE 2 — In Cooling Stage 2 mode, the Fan Enable, compressor and RV relays remain on. The Fan Speed relay is turned on immediately and turned off immediately once the Cooling Stage 2 demand is removed. The control reverts to Cooling Stage 1 mode. If there is a master/slave or dual compressor application, all compressor relays and related functions will track with their associated DIP switch 2 on S1.

NIGHT LOW LIMIT (NLL) STAGED HEATING — In NLL staged Heating mode, the override (OVR) input becomes active and is recognized as a call for heating and the control will immediately go into a Heating Stage 1 mode. With an additional 30 minutes of NLL demand, the control will go into Heating Stage 2 mode. With another additional 30 minutes of NLL demand, the control will go into Heating Stage 3 mode.

### Units with WSHP Open Multiple Protocol —

The WSHP Open multi-protocol controller will control mechanical cooling, heating and waterside economizer outputs based on its own space temperature input and set points. An optional CO<sub>2</sub> IAQ (indoor air quality) sensor mounted in the space can maximize the occupant comfort. The WSHP Open controller has its own hardware clock that is automatically set



when the heat pump software is downloaded to the board. Occupancy types are described in the scheduling section below. The following sections describe the functionality of the WSHP Open multi-protocol controller. All point objects referred to in this sequence of operation will be referenced to the objects as viewed in the BACview<sup>6</sup> handheld user interface.

**SCHEDULING** — Scheduling is used to start/stop the unit based on a time period to control the space temperature to specified occupied heating and cooling set points. The controller is defaulted to control by occupied set points all the time, until either a time schedule is configured with BACview<sup>6</sup>, Field Assistant, i-Vu<sup>®</sup> Open, or a third party control system to enable/disable the BAS (Building Automation System) on/off point. The local time and date must be set for these functions to operate properly. The occupancy source can be changed to one of the following:

**Occupancy Schedules** — The controller will be occupied 24/7 until a time schedule has been configured using either Field Assistant, i-Vu Open, BACview<sup>6</sup> or a third party control system to enable/disable the BAS on/off point. The BAS point can be disabled by going to Config, then Unit, then Occupancy Schedules and changing the point from enable to disable then clicking OK.

**NOTE:** This point must be enabled in order for the i-Vu Open, Field Assistant, or BACview<sup>6</sup> control system to assign a time schedule to the controller.

**Schedule schedule** — The unit will operate according to the schedule configured and stored in the unit. The schedule is accessible via the BACview<sup>6</sup> Handheld tool, i-Vu Open, or Field Assistant control system. The daily schedule consists of a start/stop time (standard or 24-hour mode) and seven days of the week, starting with Monday and ending on Sunday. To enter a daily schedule, navigate to Config, then Sched, then enter BACview<sup>6</sup> Admin Password (1111), then go to schedule\_schedule. From here, enter either a Weekly or Exception schedule for the unit.

**Occupancy Input Contact** — The WSHP Open controller has the capability to use an external dry contact closure to determine the occupancy status of the unit. The Occupancy Schedules will need to be disabled in order to utilize the occupancy contact input.

**NOTE:** Scheduling can only be controlled from one source.

**BAS (Building Automation System) On/Off** — A BAS system that supports network scheduling can control the unit through a network communication and the BAS scheduling function once the Occupancy Schedules have been disabled.

**NOTE:** Scheduling can either be controlled via the unit or the BAS, but not both.

**INDOOR FAN** — The indoor fan will operate in any one of three modes depending on the user configuration selected.

Fan mode can be selected as Auto, Continuous, or Always On. In Auto mode, the fan is in intermittent operation during both occupied and unoccupied periods. Continuous fan mode is intermittent during unoccupied periods and continuous during occupied periods. Always On mode operates the fan continuously during both occupied and unoccupied periods. In the default mode, Continuous, the fan will be turned on whenever any one of the following is true:

- The unit is in occupied mode as determined by its occupancy status.
- There is a demand for cooling or heating in the unoccupied mode.
- There is a call for dehumidification (optional).

When power is reapplied after a power outage, there will be a configured time delay of 5 to 600 seconds before starting the fan. There are also configured fan delays for Fan On and Fan Off. The Fan On delay defines the delay time (0 to 30 seconds; default 10) before the fan begins to operate after heating or

cooling is started while the Fan Off delay defines the delay time (0 to 180 seconds; default 45) the fan will continue to operate after heating or cooling is stopped. The fan will continue to run as long as the compressors, heating stages, or the dehumidification relays are on. If the SPT failure alarm or condensate overflow alarm is active; the fan will be shut down immediately regardless of occupancy state or demand.

**Fan Speed Control (During Heating)** — Whenever heat is required and active, the control continuously monitors the supply-air temperature to verify it does not rise above the configured maximum heating SAT limit (110 F default). As the SAT approaches this value, the control will increase the fan speed as required to ensure the SAT will remain within the limit. This feature provides the most quiet and efficient operation by operating the fan at the lowest speed possible.

**Fan Speed Control (During Cooling)** — Whenever mechanical cooling is required and active, the control continuously monitors the supply-air temperature to verify it does not fall below the configured minimum cooling SAT limit (50 F default). As the SAT approaches this value, the control will increase the fan speed as required to ensure the SAT will remain within the limit. The fan will operate at lowest speed to maximize latent capacity during cooling.

**COOLING** — The WSHP Open controller will operate one or two stages of compression to maintain the desired cooling set point. The compressor outputs are controlled by the PI (proportional-integral) cooling loop and cooling stages capacity algorithm. They will be used to calculate the desired number of stages needed to satisfy the space by comparing the space temperature (SPT) to the appropriate cooling set point. The water side economizer, if applicable, will be used for first stage cooling in addition to the compressor(s). The following conditions must be true in order for the cooling algorithm to run:

- Cooling is set to Enable.
- Heating mode is not active and the compressor time guard has expired.
- Condensate overflow input is normal.
- If occupied, the SPT is greater than the occupied cooling set point.
- Space temperature reading is valid.
- If unoccupied, the SPT is greater than the unoccupied cooling set point.
- If economizer cooling is available and active and the economizer alone is insufficient to provide enough cooling.
- OAT (if available) is greater than the cooling lockout temperature.

If all the above conditions are met, the compressors will be energized as required, otherwise they will be deenergized. If cooling is active and should the SAT approach the minimum SAT limit, the fan will be indexed to the next higher speed. Should this be insufficient and if the SAT falls further (equal to the minimum SAT limit), the fan will be indexed to the maximum speed. If the SAT continues to fall 5° F below the minimum SAT limit, all cooling stages will be disabled.

During Cooling mode, the reversing valve output will be held in the cooling position (either B or O type as configured) even after the compressor is stopped. The valve will not switch position until the Heating mode is required.

The configuration screens contain the minimum SAT parameter as well as cooling lockout based on outdoor-air temperature (OAT) Both can be adjusted to meet various specifications.

There is a 5-minute off time for the compressor as well as a 5-minute time delay when staging up to allow the SAT to achieve a stable temperature before energizing a second stage of capacity. Likewise, a 45-second delay is used when staging down.

After a compressor is staged off, it may be restarted again after a normal time-guard period of 5 minutes and if the supply-air temperature has increased above the minimum supply-air temperature limit.

The WSHP Open controller provides a status input to monitor the compressor operation. The status is monitored to determine if the compressor status matches the commanded state. This input is used to determine if a refrigerant safety switch or other safety device has tripped and caused the compressor to stop operating normally. If this should occur, an alarm will be generated to indicate the faulted compressor condition.

**HEATING** — The WSHP Open controller will operate one or two stages of compression to maintain the desired heating set point. The compressor outputs are controlled by the heating PI (proportional-integral) loop and heating stages capacity algorithm. They will be used to calculate the desired number of stages needed to satisfy the space by comparing the space temperature (SPT) to the appropriate heating set point. The following conditions must be true in order for the heating algorithm to run:

- Heating is set to Enable.
- Cooling mode is not active and the compressor time guard has expired.
- Condensate overflow input is normal.
- If occupied, the SPT is less than the occupied heating set point.
- Space temperature reading is valid.
- If unoccupied, the SPT is less than the unoccupied heating set point.
- OAT (if available) is less than the heating lockout temperature.

If all the above conditions are met, the heating outputs will be energized as required, otherwise they will be deenergized. If the heating is active and should the SAT approach the maximum SAT limit, the fan will be indexed to the next higher speed. Should this be insufficient, and the SAT rises further reaching the maximum heating SAT limit, the fan will be indexed to the maximum speed. If the SAT still continues to rise 5° F above the maximum limit, all heating stages will be disabled.

During Heating mode, the reversing valve output will be held in the heating position (either B or O type as configured) even after the compressor is stopped. The valve will not switch position until the Cooling mode is required.

The configuration screens contain the maximum SAT parameter as well as heating lockout based on outdoor-air temperature (OAT); both can be adjusted to meet various specifications.

There is a 5-minute off time for the compressor as well as a 5-minute time delay when staging up to allow the SAT to achieve a stable temperature before energizing a second stage of capacity. Likewise, a 45-second delay is used when staging down.

After a compressor is staged off, it may be restarted again after a normal time-guard period of 5 minutes and if the supply-air temperature has fallen below the maximum supply air temperature limit.

The WSHP Open controller provides a status input to monitor the compressor operation. The status is monitored to determine if the compressor status matches the commanded state. This input is used to determine if a refrigerant safety switch or other safety device has tripped and caused the compressor to stop operating normally. If this should occur, an alarm will be generated to indicate the faulted compressor condition. Also, if auxiliary heat is available (see below), the auxiliary heat will operate to replace the reverse cycle heating and maintain the space temperature as required.

**AUXILIARY HEAT** — The WSHP Open controller can control a two-position, modulating water, or steam valve

connected to a coil on the discharge side of the unit and supplied by a boiler or a single-stage ducted electric heater in order to maintain the desired heating set point. Should the compressor capacity be insufficient or a compressor failure occurs, the auxiliary heat will be used. Unless the compressor fails, the auxiliary heat will only operate to supplement the heat provided by the compressor if the space temperature falls more than one degree below the desired heating set point (the amount is configurable). The heat will be controlled so the SAT will not exceed the maximum heating SAT limit.

#### Auxiliary Modulating Hot Water/Steam Heating Reheat

— The control can modulate a hot water or steam valve connected to a coil on the discharge side of the unit and supplied by a boiler in order to maintain the desired heating set point should the compressor capacity be insufficient or a compressor failure occurs. Unless a compressor fault condition exists, the valve will only operate to supplement heat provided by compressor if the space temperature falls more than one degree below the desired heating set point. The valve will be controlled so the SAT will not exceed maximum heating SAT limit.

#### Two-Position Hot Water/Steam Heating Reheat

— The control can operate a two-position, NO or NC, hot water or steam valve connected to a coil on the discharge side of the unit and supplied by a boiler in order to maintain the desired heating set point should the compressor capacity be insufficient or a compressor failure occurs. Unless a compressor fault condition exists, the valve will only open to supplement the heat provided by the compressor if the space temperature falls more than one degree below the desired heating set point. The valve will be controlled so the SAT will not exceed the maximum heating SAT limit. The heat stage will also be subject to a 2-minute minimum OFF time to prevent excessive valve cycling.

#### Single Stage Electric Auxiliary Heat

— The control can operate a field-installed single stage of electric heat installed on the discharge side of the unit in order to maintain the desired heating set point should the compressor capacity be insufficient or a compressor failure occurs. Unless a compressor fault condition exists, the heat stage will only operate to supplement the heat provided by the compressor if the space temperature falls more than one degree below the desired heating set point. The heat stage will be controlled so the SAT will not exceed the maximum heating SAT limit. The heat stage will also be subject to a 2-minute minimum OFF time to prevent excessive cycling.

#### **INDOOR AIR QUALITY (IAQ) AND DEMAND CONTROLLED VENTILATION (DCV)**

— If the optional indoor air quality sensor is installed, the WSHP Open controller can maintain indoor air quality via a modulating OA damper providing demand controlled ventilation. The control operates the modulating OA damper during occupied periods. The control monitors the CO<sub>2</sub> level and compares it to the configured set points, adjusting the ventilation rate as required. The control provides proportional ventilation to meet the requirements of ASHRAE (American Society of Heating, Refrigerating and Air Conditioning Engineers) specifications by providing a base ventilation rate and then increasing the rate as the CO<sub>2</sub> level increases. The control will begin to proportionally increase ventilation when the CO<sub>2</sub> level rises above the start ventilation set point and will reach the full ventilation rate when the CO<sub>2</sub> level is at or above the maximum set point. A user-configurable minimum damper position ensures that proper base ventilation is delivered when occupants are not present. The IAQ configurations can be accessed through the configuration screen. The following conditions must be true in order for this algorithm to run:

- Damper control is configured for DCV.
- The unit is in an occupied mode.
- The IAQ sensor reading is greater than the DCV start control set point.

The control has four user adjustable set points: DCV start control set point, DCV maximum control set point, minimum damper position, and DCV maximum damper position.

**Two-Position OA Damper** — The control can be configured to operate a ventilation damper in a two-position ventilation mode to provide the minimum ventilation requirements during occupied periods.

**WATERSIDE ECONOMIZER** — The WSHP Open controller has the capability of providing modulating or two-position water economizer operation (for a field-installed economizer coil mounted to the entering air side of the unit and connected to the condenser water loop) in order to provide free cooling (or preheating) when water conditions are optimal. Water economizer settings can be accessed through the equipment status screen. The following conditions must be true for economizer operation:

- SAT reading is available.
- LWT reading is available.
- If occupied, the SPT is greater than the occupied cooling set point or less than the occupied heating set point and the condenser water is suitable.
- Space temperature reading is valid.
- If unoccupied, the SPT is greater than the unoccupied cooling set point or less than the unoccupied heating set point and the condenser water is suitable.

**Modulating Water Economizer Control** — The control has the capability to modulate a water valve to control condenser water flowing through a coil on the entering air side of the unit.

**Cooling** — The purpose is to provide an economizer cooling function by using the water loop when the entering water loop temperature is suitable (at least 5° F below space temperature). If the water loop conditions are suitable, then the valve will modulate open as required to maintain a supply-air temperature that meets the load conditions. Should the economizer coil capacity alone be insufficient for a period greater than 5 minutes, or should a high humidity condition occur, then the compressor will also be started to satisfy the load. Should the SAT approach the minimum cooling SAT limit, the economizer valve will modulate closed during compressor operation.

**Heating** — Additionally, the control will modulate the water valve should the entering water loop temperature be suitable for heating (at least 5° F above space temperature) and heat is required. The valve will be controlled in a similar manner except to satisfy the heating requirement. Should the economizer coil capacity alone be insufficient to satisfy the space load conditions for more than 5 minutes, then the compressor will be started to satisfy the load. Should the SAT approach the maximum heating SAT limit, the economizer valve will modulate closed during compressor operation.

**Two-Position Water Economizer Control** — The control has the capability to control a NO or NC, two-position water valve to control condenser water flow through a coil on the entering air side of the unit.

**Cooling** — The purpose is to provide a cooling economizer function directly from the condenser water loop when the entering water loop temperature is suitable (at least 5° F below space temperature). If the optional coil is provided and the water loop conditions are suitable, then the valve will open to provide cooling to the space when required. Should the capacity be insufficient for a period greater than 5 minutes, or should a high humidity condition occur, then the compressor will be started to satisfy the load. Should the SAT reach the minimum cooling SAT limit, the economizer valve will close during compressor operation.

**Heating** — Additionally, the economizer control will open the water valve should the entering water loop temperature be suitable for heating (at least 5° F above space temperature) and heat is required. The valve will be controlled in a similar

manner except to satisfy the heating requirement. Should the coil capacity be insufficient to satisfy the space load for more than 5 minutes, then the compressor will be started to satisfy the load. Should the SAT reach the maximum heating SAT limit, the economizer valve will close during compressor operation.

**DEMAND LIMIT** — The WSHP Open controller has the ability to accept three levels of demand limit from the network. In response to a demand limit, the unit will decrease its heating set point and increase its cooling set point to widen the range in order to immediately lower the electrical demand. The amount of temperature adjustment in response is user adjustable for both heating and cooling and for each demand level. The response to a particular demand level may also be set to zero.

**CONDENSER WATER LINKAGE** — The control provides optimized water loop operation using an universal controller (UC) open loop controller. Loop pump operation is automatically controlled by WSHP equipment occupancy schedules, unoccupied demand and tenant override conditions. Positive pump status feedback prevents nuisance fault trips. The condenser water linkage operates when a request for condenser water pump operation is sent from each WSHP to the loop controller. This request is generated whenever any WSHP is scheduled to be occupied, is starting during optimal start (for warm-up or pull down prior to occupancy), there is an unoccupied heating or cooling demand, or a tenant pushbutton override. At each WSHP, the water loop temperature and the loop pump status is given. The WSHP will NOT start a compressor until the loop pumps are running or will shutdown the compressors should the pumps stop. This prevents the WSHP from operating without water flow and thus tripping out on refrigerant pressure, causing a lockout condition. The WSHP Open controller control will prevent this from occurring. Also, the loop controller can be configured to start the pumps only after a configurable number of WSHPs are requesting operation (from 1-"N"). This can be used to prevent starting the entire loop operation for only one WSHP. Meanwhile, the WSHPs will not operate if the loop pump status is off and therefore the WSHP compressor will not run.

## SYSTEM TEST

System testing provides the ability to check the control operation. The control enters a 20-minute Test mode by momentarily shorting the test pins. All time delays are increased 15 times.

**Test Mode** — To enter Test mode on Complete C or Deluxe D controls, cycle the fan 3 times within 60 seconds. The LED (light-emitting diode) will flash a code representing the last fault when entering the Test mode. The alarm relay will also power on and off during Test mode. See Tables 18-20. To exit Test mode, short the terminals for 3 seconds or cycle the power 3 times within 60 seconds.

**NOTE:** The Deluxe D control has a flashing code and alarm relay cycling code that will both have the same numerical label. For example, flashing code 1 will have an alarm relay cycling code 1. Code 1 indicates the control has not faulted since the last power off to power on sequence.

**Retry Mode** — In Retry mode, the status LED will start to flash slowly to signal that the control is trying to recover from an input fault. The control will stage off the outputs and try to again satisfy the thermostat used to terminal Y. Once the thermostat input calls are satisfied, the control will continue normal operation.

**NOTE:** If 3 consecutive faults occur without satisfying the thermostat input call to terminal Y, the control will go into lockout mode. The last fault causing the lockout is stored in memory and can be viewed by entering Test mode.

**Table 18 — Complete C Control Current LED Status and Alarm Relay Operations**

LED STATUS	DESCRIPTION OF OPERATION	ALARM RELAY
<b>On</b>	Normal Mode	Open
	Normal Mode with PM Warning	Cycle (closed 5 sec., Open 25 sec.)
<b>Off</b>	Control is non-functional	Open
<b>Slow Flash</b>	Fault Retry	Open
<b>Fast Flash</b>	Lockout	Closed
<b>Slow Flash</b>	Over/Under Voltage Shutdown	Open (Closed after 15 minutes)
<b>Flashing Code 1</b>	Test Mode — No fault in memory	Cycling Code 1
<b>Flashing Code 2</b>	Test Mode — HP Fault in memory	Cycling Code 2
<b>Flashing Code 3</b>	Test Mode — LP Fault in memory	Cycling Code 3
<b>Flashing Code 4</b>	Test Mode — FP1 Fault in memory	Cycling Code 4
<b>Flashing Code 5</b>	Test Mode — FP2 Fault in memory	Cycling Code 5
<b>Flashing Code 6</b>	Test Mode — CO Fault in memory	Cycling Code 6
<b>Flashing Code 7</b>	Test Mode — Over/Under shutdown in memory	Cycling Code 7
<b>Flashing Code 8</b>	Test Mode — PM in memory	Cycling Code 8
<b>Flashing Code 9</b>	Test Mode — Test Mode — FP1/FP2 Swapped Fault in memory	Cycling Code 9

**LEGEND**

- CO** — Condensate Overflow
- FP** — Freeze Protection
- HP** — High Pressure
- LED** — Light-Emitting Diode
- LP** — Low Pressure
- PM** — Performance Monitor

**NOTES:**

1. Slow flash is 1 flash every 2 seconds.
2. Fast flash is 2 flashes every 1 second.
3. EXAMPLE: "Flashing Code 2" is represented by 2 fast flashes followed by a 10-second pause. This sequence will repeat continually until the fault is cleared.

**Table 19 — Complete C Control LED Code and Fault Descriptions**

LED CODE	FAULT	DESCRIPTION
<b>1</b>	No fault in memory	There has been no fault since the last power-down to power-up sequence
<b>2</b>	High-Pressure Switch	HP Open Instantly
<b>3</b>	Low-Pressure Switch	LP open for 30 continuous seconds before or during a call (bypassed for first 60 seconds)
<b>4</b>	Freeze Protection Coax — FP1	FP1 below Temp limit for 30 continuous seconds (bypassed for first 60 seconds of operation)
<b>5</b>	Freeze Protection Air Coil — FP2	FP2 below Temp limit for 30 continuous seconds (bypassed for first 60 seconds of operation)
<b>6</b>	Condensate overflow	Sense overflow (grounded) for 30 continuous seconds
<b>7 (Autoreset)</b>	Over/Under Voltage Shutdown	"R" power supply is <19VAC or >30VAC
<b>8</b>	PM Warning	Performance Monitor Warning has occurred.
<b>9</b>	FP1 and FP2 Thermistors are Swapped	FP1 temperature is higher than FP2 in heating/test mode, or FP2 temperature is higher than FP1 in cooling/test mode.

**LEGEND**

- FP** — Freeze Protection
- HP** — High Pressure
- LED** — Light-Emitting Diode
- LP** — Low Pressure
- PM** — Performance Monitor

**Table 20 — Aquazone™ Deluxe D Control Current LED Status and Alarm Relay Operations**

DESCRIPTION	STATUS LED (Green)	TEST LED (Yellow)	FAULT LED (Red)	ALARM RELAY
<b>Normal Mode</b>	On	Off	Flash Last Fault Code in Memory	Open
<b>Normal Mode with PM</b>	On	Off	Flashing Code 8	Cycle (closed 5 sec, open 25 sec, ...)
<b>Deluxe D Control is non-functional</b>	Off	Off	Off	Open
<b>Test Mode</b>	—	On	Flash Last Fault Code in Memory	Cycling Appropriate Code
<b>Night Setback</b>	Flashing Code 2	—	Flash Last Fault Code in Memory	—
<b>ESD</b>	Flashing Code 3	—	Flash Last Fault Code in Memory	—
<b>Invalid T-stat Inputs</b>	Flashing Code 4	—	Flash Last Fault Code in Memory	—
<b>No Fault in Memory</b>	On	Off	Flashing Code 1	Open
<b>HP Fault</b>	Slow Flash	Off	Flashing Code 2	Open
<b>LP Fault</b>	Slow Flash	Off	Flashing Code 3	Open
<b>FP1 Fault</b>	Slow Flash	Off	Flashing Code 4	Open
<b>FP2 Fault</b>	Slow Flash	Off	Flashing Code 5	Open
<b>CO Fault</b>	Slow Flash	Off	Flashing Code 6	Open
<b>Over/Under Voltage</b>	Slow Flash	Off	Flashing Code 7	Open (closed after 15 minutes)
<b>HP Lockout</b>	Fast Flash	Off	Flashing Code 2	Closed
<b>LP Lockout</b>	Fast Flash	Off	Flashing Code 3	Closed
<b>FP1 Lockout</b>	Fast Flash	Off	Flashing Code 4	Closed
<b>FP2 Lockout</b>	Fast Flash	Off	Flashing Code 5	Closed
<b>CO Lockout</b>	Fast Flash	Off	Flashing Code 6	Closed

**LEGEND**

- CO** — Condensate Overflow
- ESD** — Emergency Shutdown
- FP** — Freeze Protection
- HP** — High Pressure
- LP** — Low Pressure
- PM** — Performance Monitor

**NOTES:**

1. If there is no fault in memory, the Fault LED will flash code 1.
2. Codes will be displayed with a 10-second Fault LED pause.
3. Slow flash is 1 flash every 2 seconds.
4. Fast flash is 2 flashes every 1 second.
5. EXAMPLE: "Flashing Code 2" is represented by 2 fast flashes followed by a 10-second pause. This sequence will repeat continually until the fault is cleared.

**Aquazone™ Deluxe D Control LED Indicators** — There are 3 LED indicators on the Deluxe D control. See Table 20.

**STATUS LED** — Status LED indicates the current status or mode of the Deluxe D control. The Status LED light is green.

**TEST LED** — Test LED will be activated any time the Deluxe D control is in test mode. The Test LED light is yellow.

**FAULT LED** — Fault LED light is red. The fault LED will always flash a code representing the last fault in memory. If there is no fault in memory, the fault LED will flash code 1 on and appear as 1 fast flash alternating with a 10-second pause. See Table 20.

**WSHP Open Test Mode** — To enter WSHP Open test mode, navigate from the BACview<sup>6</sup> home screen to the configuration screen. Choose the service screen and enable unit test. The controller will then test the following:

**FAN TEST** — Tests all fan speeds, sequences fan from low to high, and operates each speed for one minute. Resets to disable on completion.

**COMPRESSOR TEST** — Tests compressor cooling and heating operation. Sequences cooling stage 1 then cooling stage 2 followed by heating stage 2 then reduces capacity to heating stage 1. Operates for 1 minute per step.

**DEHUMIDIFICATION TEST** — Tests dehumidification mode. Operates for 2 minutes.

**AUXILIARY HEATING TEST** — Tests auxiliary heat. Sequences fan on and enables heating coil for 1 minute.

**H<sub>2</sub>O ECONOMIZER TEST** — Tests entering/returning water loop economizer operation. Sequences fan and opens economizer water valve for one minute.

**OPEN VENT DAMPER 100% TEST** — Tests outside air (OA) damper operation.

**PREPOSITION OA DAMPER** — Prepositions OA damper actuator to set proper preload.

**NOTE:** The auxiliary heating test, H<sub>2</sub>O economizer test, open vent damper 100% test, and preposition OA damper features will not be visible on the screen unless configured.

Once tests are complete, set unit test back to disable. Unit will automatically reset to disable after 1 hour.

## SERVICE

Perform the procedures outlined below periodically, as indicated.

**IMPORTANT:** When a compressor is removed from this unit, system refrigerant circuit oil will remain in the compressor. To avoid leakage of compressor oil, the refrigerant lines of the compressor must be sealed after it is removed.

**IMPORTANT:** All refrigerant discharged from this unit must be recovered without exception. Technicians must follow industry accepted guidelines and all local, state and federal statutes for the recovery and disposal of refrigerants.

**IMPORTANT:** To avoid the release of refrigerant into the atmosphere, the refrigerant circuit of this unit must only be serviced by technicians which meet local, state and federal proficiency requirements.

**IMPORTANT:** To prevent injury or death due to electrical shock or contact with moving parts, open unit disconnect switch before servicing unit.

**Filters** — Filters must be clean for maximum performance. Inspect filters every month under normal operating conditions. replace when necessary.

**IMPORTANT:** Units should never be operated without a filter.

**Water Coil** — Keep all air out of the water coil. Check open loop systems to be sure the well head is not allowing air to infiltrate the water line. Always keep lines airtight.

Inspect heat exchangers regularly, and clean more frequently if the unit is located in a “dirty” environment. The heat exchanger should be kept full of water at all times. Open loop systems should have an inverted P trap placed in the discharge line to keep water in the heat exchanger during off cycles. Closed loop systems must have a minimum of 15 psi during the summer and 40 psi during the winter.

Check P trap frequently for proper operation.

### CAUTION

To avoid fouled machinery and extensive unit clean-up, DO NOT operate units without filters in place. DO NOT use equipment as a temporary heat source during construction.

**Condensate Drain Pans** — Check condensate drain pans for algae growth twice a year. If algae growth is apparent, consult a water treatment specialist for proper chemical treatment. The application of an algicide every three months will typically eliminate algae problems in most locations.

**Refrigerant System** — Verify air and water flow rates are at proper levels before servicing. To maintain sealed circuitry integrity, do not install service gages unless unit operation appears abnormal. Check to see that unit is within the superheat and subcooling ranges.

**Condensate Drain Cleaning** — Clean the drain line and unit drain pan at the start of each cooling season. Check flow by pouring water into drain. Be sure trap is filled to maintain an air seal.

**Air Coil Cleaning** — Remove dirt and debris from evaporator coil as required by condition of the coil. Clean coil with a stiff brush, vacuum cleaner, or compressed air. Use a fin comb of the correct tooth spacing when straightening mashed or bent coil fins.

**Condenser Cleaning** — Water-cooled condensers may require cleaning of scale (water deposits) due to improperly maintained closed-loop water systems. Sludge build-up may need to be cleaned in an open water tower system due to induced contaminants.

Local water conditions may cause excessive fouling or pitting of tubes. Condenser tubes should therefore be cleaned at least once a year, or more often if the water is contaminated.

Proper water treatment can minimize tube fouling and pitting. If such conditions are anticipated, water treatment analysis is recommended. Refer to the Carrier System Design Manual, Part 5, for general water conditioning information.

### CAUTION

Follow all safety codes. Wear safety glasses and rubber gloves when using inhibited hydrochloric acid solution. Observe and follow acid manufacturer’s instructions. Failure to follow these safety precautions could result in personal injury or equipment or property damage.

Clean condensers with an inhibited hydrochloric acid solution. The acid can stain hands and clothing, damage concrete, and, without inhibitor, damage steel. Cover surroundings to guard against splashing. Vapors from vent pipe are not harmful, but take care to prevent liquid from being carried over by the gases.

Warm solution acts faster, but cold solution is just as effective if applied for a longer period.

**GRAVITY FLOW METHOD** — Do not add solution faster than vent can exhaust the generated gases.

When condenser is full, allow solution to remain overnight, then drain condenser and flush with clean water. Follow acid manufacturer's instructions. See Fig. 23.

**FORCED CIRCULATION METHOD** — Fully open vent pipe when filling condenser. The vent may be closed when condenser is full and pump is operating. See Fig. 24.

Regulate flow to condenser with a supply line valve. If pump is a nonoverloading type, the valve may be fully closed while pump is running.

For average scale deposit, allow solution to remain in condenser overnight. For heavy scale deposit, allow 24 hours. Drain condenser and flush with clean water. Follow acid manufacturer's instructions.

**Checking System Charge** — Units are shipped with full operating charge. If recharging is necessary:

1. Insert thermometer bulb in insulating rubber sleeve on liquid line near filter drier. Use a digital thermometer for all temperature measurements. DO NOT use a mercury or dial-type thermometer.
2. Connect pressure gage to discharge line near compressor.
3. After unit conditions have stabilized, read head pressure on discharge line gage.

NOTE: Operate unit a minimum of 15 minutes before checking charge.

4. From standard field-supplied Pressure-Temperature chart for R-410A, find equivalent saturated condensing temperature.
5. Read liquid line temperature on thermometer; then subtract from saturated condensing temperature. The difference equals subcooling temperature.

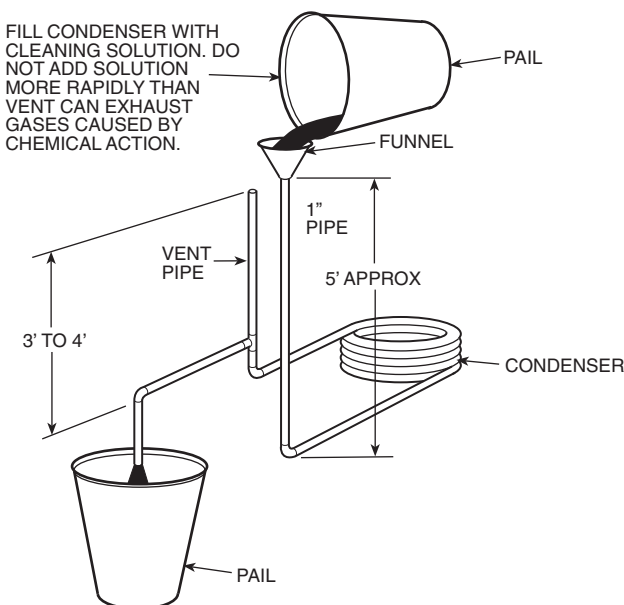


Fig. 23 — Gravity Flow Method

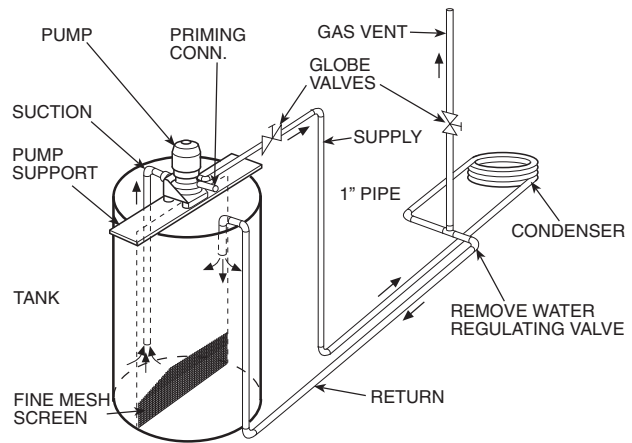


Fig. 24 — Forced Circulation Method

6. ADD refrigerant to raise the temperature or REMOVE refrigerant (using standard practices) to lower the temperature (allow a tolerance of  $\pm 3^\circ \text{F}$ ), as required.

### Refrigerant Charging

#### ⚠ WARNING

To prevent personal injury, wear safety glasses and gloves when handling refrigerant. Do not overcharge system — this can cause compressor flooding.

NOTE: Do not vent or depressurize unit refrigerant to atmosphere. Remove and recover refrigerant following accepted practices.

### Air Coil Fan Motor Removal

#### ⚠ CAUTION

Before attempting to remove fan motors or motor mounts, place a piece of plywood over evaporator coils to prevent coil damage.

Motor power wires need to be disconnected from motor terminals before motor is removed from unit.

1. Shut off unit main power supply.
2. Loosen bolts on mounting bracket so that fan belt can be removed.
3. Loosen and remove the 2 motor mounting bracket bolts on left side of bracket.
4. Slide motor/bracket assembly to extreme right and lift out through space between fan scroll and side frame. Rest motor on a high platform such as a step ladder. Do not allow motor to hang by its power wires.

**Replacing the WSHP Open Controller's Battery** — The WSHP Open controller's 10-year lithium CR2032 battery provides a minimum of 10,000 hours of data retention during power outages.

NOTE: Power must be ON to the WSHP Open controller when replacing the battery, or the date, time and trend data will be lost.

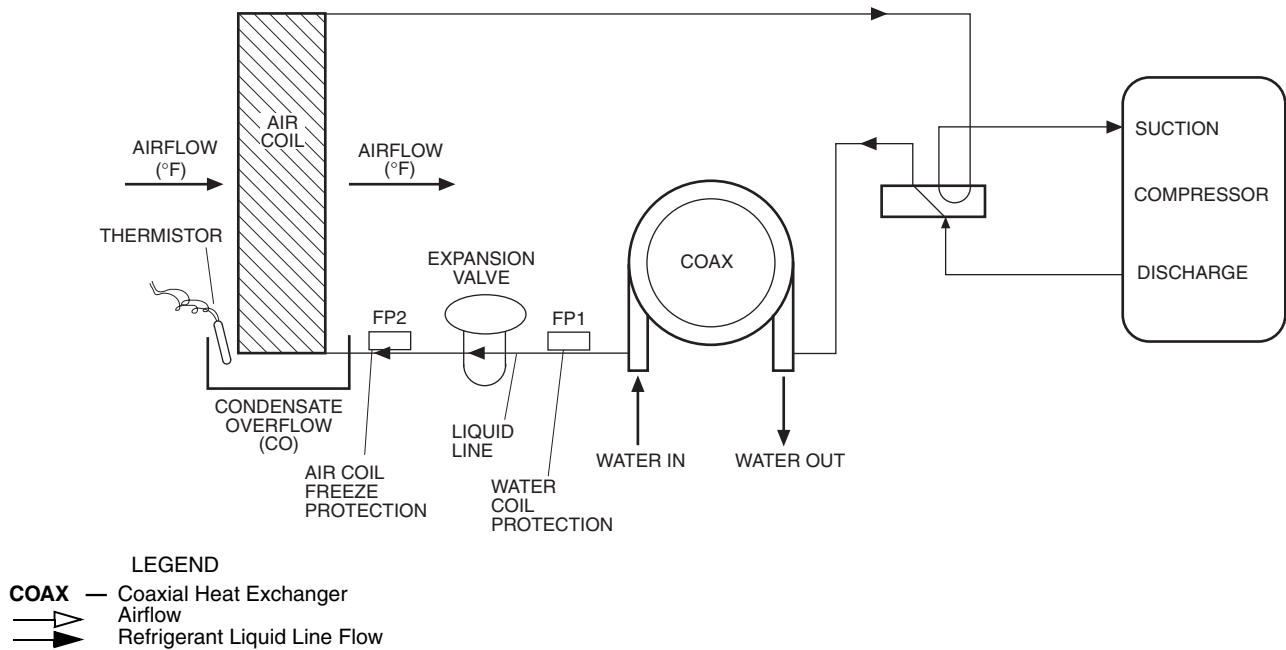
1. Remove the battery from the controller, making note of the battery's polarity.
2. Insert the new battery, matching the battery's polarity with the polarity indicated on the WSHP Open controller.

## TROUBLESHOOTING

When troubleshooting problems with a WSHP, consider the causes and solutions in Table 21.

**Thermistor** — A thermistor may be required for single-phase units where starting the unit is a problem due to low voltage.

**Control Sensors** — The control system employs 2 nominal 10,000 ohm thermistors (FP1 and FP2) that are used for freeze protection. Be sure FP1 is located in the discharge fluid and FP2 is located in the air discharge. See Fig. 25.



**Fig. 25 — FP1 and FP2 Thermistor Location**

**Table 21 — Troubleshooting**

FAULT	HEATING	COOLING	POSSIBLE CAUSE	SOLUTION
<b>Main Power Problems</b>	X	X	Green Status LED Off	Check line voltage circuit breaker and disconnect.
				Check for line voltage between L1 and L2 on the contactor.
				Check for 24 VAC between R and C on controller.
				Check primary/secondary voltage on transformer.
<b>HP Fault — Code 2 High Pressure</b>		X	Reduced or no water flow in cooling	Check pump operation or valve operation/setting. Check water flow adjust to proper flow rate.
		X	Water temperature out of range in cooling	Bring water temperature within design parameters.
	X		Reduced or no airflow in heating	Check for dirty air filter and clean or replace. Check fan motor operation and airflow restrictions. Dirty air coil — construction dust etc. External static too high. Check Tables 4-12.
	X		Air temperature out of range in heating	Bring return air temperature within design parameters.
	X	X	Overcharged with refrigerant	Check superheat/subcooling vs typical operating condition.
	X	X	Bad HP switch	Check switch continuity and operation. Replace.
<b>LP/LOC Fault — Code 3 Low Pressure/Loss of Charge</b>	X	X	Insufficient charge	Check for refrigerant leaks.
	X		Compressor pump down at start-up	Check charge and start-up water flow.
<b>FP1 Fault — Code 4 Water Freeze Protection</b>	X		Reduced or no water flow in heating	Check pump operation or water valve operation/setting. Plugged strainer or filter. Clean or replace. Check water flow adjust to proper flow rate.
		X	Inadequate antifreeze level	Check antifreeze density with hydrometer.
		X	Improper freeze protect setting (30 F vs 10 F)	Clip JW2 jumper for antifreeze (10 F) use.
	X		Water temperature out of range	Bring water temperature within design parameters.
	X	X	Bad thermistor	Check temperature and impedance correlation.
	<b>FP2 Fault — Code 5 Air Coil Freeze Protection</b>		X	Reduced or no airflow in cooling
		X	Air temperature out of range	Too much cold vent air. Bring entering air temperature within design parameters.
		X	Improper freeze protect setting (30 F vs 10 F)	Normal airside applications will require 30 F only.
X		X	Bad thermistor	Check temperature and impedance correlation.
<b>Condensate Fault — Code 6</b>	X	X	Blocked drain	Check for blockage and clean drain.
	X	X	Improper trap	Check trap dimensions and location ahead of vent.
		X	Poor drainage	Check for piping slope away from unit. Check slope of unit toward outlet. Poor venting. Check vent location.
		X	Moisture on sensor	Check for moisture shorting to air coil.
<b>Over/Under Voltage — Code 7 (Auto Resetting)</b>	X	X	Under voltage	Check power supply and 24 VAC voltage before and during operation. Check power supply wire size. Check compressor starting. Check 24 VAC and unit transformer tap for correct power supply voltage.
			Over voltage	Check power supply voltage and 24 VAC before and during operation. Check 24 VAC and unit transformer tap for correct power supply voltage.
<b>Performance Monitor — Code 8</b>	X		Heating mode FP2>125 F	Check for poor airflow or overcharged unit.
		X	Cooling mode FP1>125 F OR FP2< 40 F	Check for poor water flow or airflow.
<b>FP1 and FP2 Thermistors — Code 9</b>	X		FP1 temperature is higher than FP2 temperature	Swap FP1 and FP2 thermistors.
		X	FP2 temperature is higher than FP1 temperature	Swap FP1 and FP2 thermistors.
<b>No Fault Code Shown</b>	X	X	No compressor operation	See scroll compressor rotation section.
	X	X	Compressor overload	Check and replace if necessary.
	X	X	Control board	Reset power and check operation.
<b>Unit Short Cycles</b>	X	X	Dirty air filter	Check and clean air filter.
	X	X	Unit in 'Test Mode'	Reset power or wait 20 minutes for auto exit.
	X	X	Unit selection	Unit may be oversized for space. Check sizing for actual load of space.
	X	X	Compressor overload	Check and replace if necessary.
<b>Only Fan Runs</b>	X	X	Thermostat position	Ensure thermostat set for heating or cooling operation.
	X	X	Unit locked out	Check for lockout codes. Reset power.
	X	X	Compressor overload	Check compressor overload. Replace if necessary.
	X	X	Thermostat wiring	Check Y and W wiring at heat pump. Jumper Y and R for compressor operation in Test mode.

LEGEND

RV — Reversing Valve



**Table 21 — Troubleshooting (cont)**

FAULT	HEATING	COOLING	POSSIBLE CAUSE	SOLUTION	
<b>Only Compressor Runs</b>	X	X	Thermostat wiring	Check G wiring at heat pump. Jumper G and R for fan operation.	
	X	X	Fan motor relay	Jumper G and R for fan operation. Check for line voltage across BR contacts. Check fan power enable relay operation (if present).	
	X	X	Fan motor	Check for line voltage at motor. Check capacitor.	
	X	X	Thermostat wiring	Check Y and W wiring at heat pump. Jumper Y and R for compressor operation in test mode.	
<b>Unit Does Not Operate in Cooling</b>		X	Reversing valve	Set for cooling demand and check 24 VAC on RV coil and at control. If RV is stuck, run high pressure up by reducing water flow and while operating engage and disengage RV coil voltage to push valve.	
		X	Thermostat setup	Check for 'O' RV setup not 'B'.	
		X	Thermostat wiring	Check O wiring at heat pump. Jumper O and R for RV coil 'Click'.	
<b>Insufficient Capacity/ Not Cooling or Heating Properly</b>	X	X	Dirty filter	Replace or clean.	
	X		Reduced or no airflow in heating	Check for dirty air filter and clean or replace. Check fan motor operation and airflow restrictions. External static too high. Check blower Tables 4-12.	
		X	Reduced or no airflow in cooling	Check for dirty air filter and clean or replace. Check fan motor operation and airflow restrictions. External static too high. Check blower Tables 4-12.	
	X	X	Leaky ductwork	Check supply and return air temperatures at the unit and at distant duct registers if significantly different, duct leaks are present.	
	X	X	Low refrigerant charge	Check superheat and subcooling .	
	X	X	Restricted metering device	Check superheat and subcooling. Replace metering device.	
		X	Defective reversing valve	Perform RV touch test.	
	X	X	Thermostat improperly located	Check location and for air drafts behind thermostat.	
	X	X	Unit undersized	Recheck loads and sizing check sensible cooling load and heat pump capacity.	
	X	X	Scaling in water heat exchanger	Perform Scaling check and clean if necessary.	
	X	X	Inlet water too hot or cold	Check load, loop sizing, loop backfill, ground moisture.	
	<b>High Head Pressure</b>	X		Reduced or no airflow in heating	Check for dirty air filter and clean or replace. Check fan motor operation and airflow restrictions. External static too high. Check blower Tables 4-12.
			X	Reduced or no water flow in cooling	Check pump operation or valve operation/setting. Check water flow and adjust to proper flow rate.
		X	Inlet water too hot	Check load, loop sizing, loop backfill, ground moisture.	
X			Air temperature out of range in heating	Bring return air temperature within design parameters.	
		X	Scaling in water heat exchanger	Perform Scaling check and clean if necessary.	
X		X	Unit overcharged	Check superheat and subcooling. Reweigh in charge.	
X		X	Non-condensables in system	Vacuum system and reweigh in charge.	
X		X	Restricted metering device	Check superheat and subcooling. Replace metering device.	
<b>Low Suction Pressure</b>	X		Reduced water flow in heating	Check pump operation or water valve operation/setting. Plugged strainer or filter. Clean or replace. Check water flow adjust to proper flow rate.	
	X		Water temperature out of range	Bring water temperature within design parameters.	
		X	Reduced airflow in cooling	Check for dirty air filter and clean or replace. Check fan motor operation and airflow restrictions. External static too high. Check blower Tables 4-12.	
		X	Air temperature out of range	Too much cold vent air. Bring entering air temperature within design parameters.	
	X	X	Insufficient charge	Check for refrigerant leaks.	
<b>Low Discharge Air Temperature in Heating</b>	X		Airflow too high	Check blower Tables 4-12.	
	X		Poor performance	See 'Insufficient Capacity'.	
<b>High Humidity</b>		X	Airflow too high	Check blower Tables 4-12.	
		X	Unit oversized	Recheck loads and sizing check sensible cooling load and heat pump capacity.	

LEGEND

RV — Reversing Valve

## APPENDIX A — WSHP OPEN SCREEN CONFIGURATION

SCREEN NAME	PASSWORD LEVEL	POINT NAME	EDITABLE	RANGE	DEFAULT	NOTES
Equipment Status	No Password Required	Operating Mode		Off, Fan Only, Economize, Cooling, Heating, Cont Fan, Test, Start Delay, Dehumidify		Displays unit operating mode
		SPT		° F		Displays SPT
		SAT		° F		Displays SAT
		Condenser Leaving Temperature		° F		Displays leaving condenser water temperature
		Condenser Entering Temperature		° F		Displays entering condenser water temperature (Value will not update when compressor is operating)
		Fan		Off/Low Speed/ Medium Speed High Speed/On		Displays fan speed status
		Compressor Capacity		0 - 100%		Displays compressor capacity
		Damper Position		0 - 100%		Displays current damper position (Viewable only if Ventilation DMP Type = 2 position or DCV)
		H <sub>2</sub> O Economizer		0 - 100%		Displays position of economizer valve
		Auxiliary Heat		0 - 100%		Displays position of auxiliary reheat valve (Viewable only if Leaving Air Auxiliary Heat Type = 2 position, 1 stage Elect or Modulating)
		Space RH		0 - 100%		Displays space RH% (Viewable only if Humidity Sensor = Installed)
		Dehumidification		Inactive/Active		Displays if dehumidification is active (Viewable only if Factory Dehumidification Reheat = Installed)
IAQ CO <sub>2</sub>		0 - 9999 ppm		Displays the space CO <sub>2</sub> level		
Alarm Status	No Password Required	SPT Alarm Status		Normal/Alarm		Displays current space temperature condition
		Alarming SPT		° F		Displays the SPT that exceeded the alarm limit (when SPT alarm above is in Alarm)
		SPT Alarm Limit		° F		Displays the SPT alarm limit that was exceeded; causing the alarm condition (when SPT alarm above is in Alarm)
		SPT Sensor Alarm Status		Normal/Alarm		Displays the status of the Rnet SPT sensor - ALARM is displayed should the sensor fail to communicate with the control module
		IAQ Alarm Status		Normal/Alarm		Current IAQ/ventilation condition
		Compressor Alarm Status		Normal/Alarm		Current compressor condition
		SAT Alarm Status		Normal/Alarm		Current SAT condition
		Condensate Overflow Alarm Status		Normal/Alarm		Current status of the condensate drain (overflow switch)
		Condenser Water Temperature Alarm Status		Normal/Alarm		Current status of the condenser water
		Filter Alarm Status		Normal/Alarm		Current filter condition
		Space RH Alarm Status		Normal/Alarm		Current space RH condition
		OAT Alarm Status		Normal/Alarm		Current status of the OAT broadcast function
		Airside Linkage Status		Normal/Alarm		Current linkage status if enabled
Condenser Water Linkage		Normal/Alarm		Current linkage status if enabled		
Sensor Calibration	Admin Password level access only	SAT		° F		Display SAT
		SAT Offset	X	-9.9 - 10.0 ° F	0 ° F	Used to correct sensor reading
		Leaving Condenser Water Temperature		° F		Displays Leaving Condenser Water Temperature
		Leaving CW Offset	X	-9.9 - 10.0 ° F	0 ° F	Used to correct sensor reading
		Rnet Sensor Temperature		° F		Displays SPT
		Rnet Offset	X	-9.9 - 10.0 ° F	0 ° F	Used to correct sensor reading
		RH		%		Displays Space RH value
RH Sensor Offset	X	-15% - 15%	0 %	Used to correct sensor reading		

### LEGEND

- BAS** — Building Automation System
- DCV** — Demand Controlled Ventilation
- ECM** — Electronically Commutated Motor
- IAQ** — Indoor Air Quality
- OAT** — Outdoor Air Temperature
- RH** — Relative Humidity
- SAT** — Supply Air Temperature
- SPT** — Space Temperature
- TPI** — Third Party Integration

## APPENDIX A — WSHP OPEN SCREEN CONFIGURATION (cont)

SCREEN NAME	PASSWORD LEVEL	POINT NAME	EDITABLE	RANGE	DEFAULT	NOTES
<b>Unit Maintenance</b>	No Password required	Operating Mode		Off, Fan Only, Economize, Cooling, Heating, Cont Fan, Test, Start Delay, Dehumidify		Displays unit operating mode
		Fan Operating Mode		Auto/Continuous/Always On		Displays how the fan is configured to operate
		Occupancy Status		Unoccupied/Occupied		Displays the current occupancy status
		Occupancy Control		Always Occupied/Local Schedule/BACnet Schedule/BAS Keypad/Occupied Contact/Holiday Schedule/Override Schedule/Pushbutton Override/Unoccupied None		Displays the origin of the occupancy control
		Outside Air Temperature		° F		Displays OAT (Viewable only if OAT is a network broadcast)
		SPT		° F		Displays SPT
		SPT Status		Normal/Above Limit/Below Limit/Sensor Failure		Displays the SPT status
		SPT Sensor Status		Inactive/Connected		Displays the connection status of the Rnet sensor
		Condensate Overflow		Normal/Alarm		Displays the status of the condensate overflow
		Cooling Set Point		° F		Displays the actual set point being used for cooling control
		Heating Set Point		° F		Displays the actual set point being used for heating control
		Set Point Adjustment		° F		Displays the offset values from the Rnet user set point adjustment that is being applied to the configured set points
		Auxiliary Heat Control Set Point		° F		Displays the calculated set point being used for auxiliary heating control
		H <sub>2</sub> O Economizer Control Set Point		° F		Displays the calculated set point being used for economizer control
		Calculated IAQ/Ventilation Damper position		%		Displays the ventilation damper position calculated by the DCV control
		Active Compressor Stages		0/1/2		Displays the actual number of compressor stages operating
		SAT		° F		Displays SAT
		Reset Filter Alarm	X	No/Yes		Used to reset the filter alarm timer after the filter has been cleaned or replaced
		Overflow Contact		Closed/Open		Displays the state of the condensate overflow switch contact
		Occupancy Contact		Closed/Open		Displays the state of the external/remote occupancy input switch contact
BAS/Keypad Override	X	Inactive/Occupied/Unoccupied		Inactive	Provides capability to force the equipment to operate in an occupied or unoccupied mode	
OAT Input		N/A / Network			Displays if an OAT value is being received from the Network	
<b>System Settings</b>		BACnet	X			See TPI
		Keypad Configuration	X			Mapping
		Password	X			Changes password
		Network	X			See TPI
		BACnet Time Master	X			See TPI
		Clock Set	X			Changes clock/time setting
<b>Occupancy Maintenance</b>	No Password required	Override Schedules		Inactive/Active Occupied		Used to display the active and inactive occupancy control inputs
		Pushbutton Override		Inactive/Active Occupied		
		Keypad Override		Inactive/Active Occupied/Active Unoccupied		
		Schedules		Inactive/Active Occupied		
		Occupancy Contact		Inactive/Active Occupied		
		BAS on/off		Inactive/Active Occupied		
<b>Schedule Configuration</b>	User/Admin Password level access	Local Occupancy Schedules	X	Disable/Enable	Enable	Used to define which occupancy inputs are used to determine occupancy mode.
		Local Holiday Schedules	X	Disable/Enable	Disable	
		Local Override Schedules	X	Disable/Enable	Disable	
		BACnet Occupancy Schedules	X	Disable/Enable	Disable	

### LEGEND

**BAS** — Building Automation System  
**DCV** — Demand Controlled Ventilation  
**ECM** — Electronically Commutated Motor  
**IAQ** — Indoor Air Quality  
**OAT** — Outdoor Air Temperature  
**RH** — Relative Humidity  
**SAT** — Supply Air Temperature  
**SPT** — Space Temperature  
**TPI** — Third Party Integration

## APPENDIX A — WSHP OPEN SCREEN CONFIGURATION (cont)

SCREEN NAME	PASSWORD LEVEL	POINT NAME	EDITABLE	RANGE	DEFAULT	NOTES
<b>Configuration</b> ↓ <b>Set Points</b>	User/Admin Password level access	Occupied Heating	X	40 - 90 ° F	72 ° F	Defines the Occupied Heating Set Point
		Occupied Cooling	X	55 - 99 ° F	76 ° F	Defines the Occupied Cooling Set Point
		Unoccupied Heating	X	40 - 90 ° F	55 ° F	Defines the Unoccupied Heating Set Point
		Unoccupied Cooling	X	55 - 99 ° F	90 ° F	Defines the Unoccupied Cooling Set Point
		Effective Heating Set Point	X	0 - 10 ° F		Takes into effect bias (maximum allowable set point deviation)
		Effective Cooling Set Point	X	0 - 10 ° F		Takes into effect bias (maximum allowable set point deviation)
		Optimal Start				Uses historical data to calculate ramp up time so as to be at set point at occupied/unoccupied time
		Occupied RH Set Point	X	0 - 100%	65%	Defines the control set point used during occupied periods (Viewable only if Humidity Sensor = Installed/ Determines when to start Dehumidification when occupied)
		Unoccupied RH Set Point	X	0 - 100%	90%	Defines the control set point used during unoccupied periods (Viewable only if Humidity Sensor = Installed/Determines when to start Dehumidification when unoccupied)
		DCV CTRL Start Set Point	X	0 - 9999 ppm	500 ppm	Defines the control set point used to start increasing ventilation during occupied periods (Viewable only if Ventilation DMP Type = DCV)
DCV Max CTRL Set Point	X	0 - 9999 ppm	1050 ppm	Defines the control set point used to define where the ventilation will reach its maximum limit during occupied periods (Viewable only if Ventilation DMP Type = DCV/Used to determine DCV ending control point)		
<b>Configuration</b> ↓ <b>Schedule</b> ↓ <b>Weekly Schedule</b>	User/Admin Password level access	Start Time	X	00:00 - 23:59	06:00	Defines the start time for an occupied period
		End Time	X	00:00 - 24:00	18:00	Defines the ending time of an occupied period
		Mon	X	No/Yes	Yes	Determines if this day is included in this schedule
		Tue	X	No/Yes	Yes	Determines if this day is included in this schedule
		Wed	X	No/Yes	Yes	Determines if this day is included in this schedule
		Thur	X	No/Yes	Yes	Determines if this day is included in this schedule
		Fri	X	No/Yes	Yes	Determines if this day is included in this schedule
		Sat	X	No/Yes	No	Determines if this day is included in this schedule
Sun	X	No/Yes	No	Determines if this day is included in this schedule		
<b>Configuration</b> ↓ <b>Schedule</b> ↓ <b>Exception Schedules 1 - 12</b>	User/Admin Password level access	Start Month	X	0 - 12	0	Defines the start month of this holiday schedule
		Start Day	X	0 - 31	0	Defines the start day of this holiday schedule
		Start Time	X	00:00 - 23:59	0:00	Determines the start time for this schedule
		End Month	X	0 - 12	0	Defines the month to end this holiday schedule
		End Day	X	0 - 31	0	Defines the day to end this holiday schedule
		End Time	X	00:00 - 24:00	0:00	Determines the time to end this schedule

### LEGEND

**BAS** — Building Automation System  
**DCV** — Demand Controlled Ventilation  
**ECM** — Electronically Commutated Motor  
**IAQ** — Indoor Air Quality  
**OAT** — Outdoor Air Temperature  
**RH** — Relative Humidity  
**SAT** — Supply Air Temperature  
**SPT** — Space Temperature  
**TPI** — Third Party Integration

## APPENDIX A — WSHP SCREEN OPEN CONFIGURATION (cont)

SCREEN NAME	PASSWORD LEVEL	POINT NAME	EDITABLE	RANGE	DEFAULT	NOTES
<b>Configuration</b> ↓ <b>Unit Configuration</b>	Admin Password level access only	Fan Mode	X	Auto/Continuous/ Always On	Continuous	Auto= Intermittant operation during both occupied and unoccupied periods/ Continuous = Intermittant during unoccupied periods and continuous during occupied periods/Always on = fan operates continuously during both occupied and unoccupied periods
		Fan On Delay	X	0 - 30 sec	10 sec	Defines the delay time before the fan begins to operate after heating or cooling is started
		Fan Off Delay	X	0 - 180 sec	45 sec	Defines the amount of time the fan will continue to operate after heating or cooling is stopped
		Heating Enable	X	Disable/Enable	Enable	Provides capability to manually disable heating operation
		Cooling Enable	X	Disable/Enable	Enable	Provides capability to manually disable cooling operation
		Minimum SAT in Cooling	X	40 - 60 ° F	50 ° F	Defines the minimum acceptable operating temperature for the Supply Air
		Maximum SAT in Heating	X	80 - 140 ° F	110 ° F	Defines the maximum acceptable operating temperature for the Supply Air
		Damper Ventilation Position	X	0 - 100%	100%	Normally set to 100% if 2 position damper type or set to minimum ventilation position if damper type = DCV
		DCV Maximum Vent Position	X	0 - 100%	100%	Usually set at 100% - Used to limit maximum damper opening in DCV mode
		Filter Alarm Timer	X	0 - 9999 hrs	0 hrs	Disables Filter Alarm if set to 0
		Pushbutton Override	X	Disable/Enable	Enable	Enables Override Feature on Rnet sensor
		SPT Sensor Set Point Adjustment	X	Disable/Enable	Enable	Enables Set Point adjustment capability on Rnet Sensor
		Lockout Cooling if OAT <	X	-65 - 80 ° F	-65 ° F	Cooling is locked out when OAT is less than configured value and OAT is actively being broadcast
		Lockout Heating if OAT >	X	35 - 150 ° F	150 ° F	Heating is locked out when OAT is greater than configured value and OAT is actively being broadcast
		Power Fail Restart Delay	X	0 - 600 sec	60 sec	Delay before equipment starts
Occupancy Schedules	X	Disable/Enable	Enable	Enables unit occupied		
Set Point Separation	X	2 - 9 ° F	4 ° F	Used to enforce minimum set point separation		
<b>Configuration</b> ↓ <b>Service</b> ↓ <b>Test</b>	Admin Password level access only	Test Mode	X	Disable/Enable	Disable	Used to enable test mode. Will automatically reset to disable after 1 hour
		Fan Test	X	Disable/Enable	Disable	Used to test all fan speeds. Sequences fan from low to high and operates each speed for 1 minute. Resets to disable on completion
		Fan Speed		Off/Low Speed/Medium Speed/High Speed/On		Displays current fan operation
		Compressor Test	X	Disable/Enable	Disable	Used to test compressor cooling and heating operation. Sequences cooling stage 1, then stage 2, then heating stage 2 and reduces capacity to stage 1. Operates for 1 minute per step. Resets to disable on completion.
		Dehumidification Test	X	Disable/Enable	Disable	Used to test dehumidification mode - Operates for 2 minutes. Resets to disable on completion.
		Testing Compressor		Inactive/Heating/Cooling/Dehumidify/TimeGard Wait		Displays compressor test mode
		Aux Heating Test	X	Disable/Enable	Disable	Used to test auxiliary heat. Sequences fan on and enables heating coil for 1 minute. Resets to disable on completion
		H <sub>2</sub> O Economizer Test	X	Disable/Enable	Disable	Used to test entering/return air water loop economizer coil operation. Sequences fan on and opens economizer coil water valve for 1 minute. Resets to disable on completion
		Preposition OA Damper	X	Disable/Enable	Disable	Used to preposition OA damper actuator to set proper preload
		Open Vent Damper 100%	X	Disable/Enable	Disable	Used to test OA damper operation
		SAT		° F		Displays SAT
		LCWT		° F		Displays Leaving Condenser Water Temperature

### LEGEND

<b>BAS</b>	— Building Automation System
<b>DCV</b>	— Demand Controlled Ventilation
<b>ECM</b>	— Electronically Commutated Motor
<b>IAQ</b>	— Indoor Air Quality
<b>OAT</b>	— Outdoor Air Temperature
<b>RH</b>	— Relative Humidity
<b>SAT</b>	— Supply Air Temperature
<b>SPT</b>	— Space Temperature
<b>TPI</b>	— Third Party Integration

## APPENDIX A — WSHP SCREEN OPEN CONFIGURATION (cont)

SCREEN NAME	PASSWORD LEVEL	POINT NAME	EDITABLE	RANGE	DEFAULT	NOTES
<b>Configuration</b> ↓ <b>Service Configuration</b>	Admin Password level access only	# of Fan Speeds	X	1,2,3	3	Used to set number of fan motor speeds
		G Output Type	X	Fan On/Fan Low	Fan On	When set to Fan On, G output is energized when ever any fan speed is active (required for ECM and Fan control board). When set to Fan Low, output is only energized for Low Speed
		Compressor Stages	X	One Stage/Two Stages	One Stage	Defines the number of stages of compression
		Reversing Valve Type	X	O type output/B type output	O type	Determines reversing valve signal output type
		Leaving Air Auxiliary Heat Type	X	None/2-Position HW/1 Stage Electric/Modulating HW	None	Determines Auxiliary Reheat Coil Type
		Entering Air Water Economizer Type	X	None/2-Position/Modulating	None	Determines Entering Air Economizer Coil Type
		2-Position Water Valve Type	X	Normally Closed/Normally Open	Normally Closed	Determines type of 2-position water valve used
		Modulating Water Valve Type	X	Normally Closed/Normally Open	Normally Closed	Determines type of modulating water valve used
		Ventilation Damper Type	X	None/2-Position/DCV	None	Determines type of ventilation damper control to be used
		Damper Actuator Type	X	(0-10 volt)/(2-10 volt)	0-10 volt	Used to determine ventilation damper output signal range (closed - open)
		Humidity Sensor	X	None/Installed	None	Set to Installed if humidity sensor is present
		Factory Dehumidification Reheat Coil	X	None/Installed	None	Set to Installed if factory-installed dehumidification reheat coil is present
		Occupancy Input Logic	X	Occupied Open/Occupied Closed	Occupied CLOSED	Used to determine external occupancy switch contact occupied state
		Condensate Switch Alarm Delay	X	5 - 600 seconds	10 sec	Delay before equipment alarms on high condensate level
		Condensate Switch Alarm State	X	Alarm OPEN/Alarm CLOSED	Alarm CLOSED	Determine Alarm state of condensate switch input
		Minimum Condenser Water Temperature in Heating	X	25 - 60 ° F	60 ° F	Determines the minimum acceptable water loop temperature to start heating
		Maximum Condenser Water Temperature in Heating	X	65 - 100 ° F	90 ° F	Determines the maximum acceptable water loop temperature to start heating
		Minimum Condenser Water Temperature in Cooling	X	30 - 60 ° F	60 ° F	Determines the minimum acceptable water loop temperature to start cooling
		Maximum Condenser Water Temperature in Cooling	X	85 - 120 ° F	95 ° F	Determines the maximum acceptable water loop temperature to start cooling
		IAQ sensor minimum input	X	0 - 5 ma	4 ma	Minimum output current (mA) for IAQ sensor
IAQ sensor maximum input	X	5 - 20 ma	20 ma	Maximum output current (mA) for IAQ sensor		
IAQ sensor minimum output	X	0 - 9999 ppm	0 ppm	Corresponding value in ppm for minimum output current		
IAQ sensor maximum output	X	0 - 9999 ppm	2000 ppm	Corresponding value in ppm for maximum output current		

### LEGEND

- BAS** — Building Automation System
- DCV** — Demand Controlled Ventilation
- ECM** — Electronically Commutated Motor
- IAQ** — Indoor Air Quality
- OAT** — Outdoor Air Temperature
- RH** — Relative Humidity
- SAT** — Supply Air Temperature
- SPT** — Space Temperature
- TPI** — Third Party Integration

## APPENDIX A — WSHP SCREEN OPEN CONFIGURATION (cont)

SCREEN NAME	PASSWORD LEVEL	POINT NAME	EDITABLE	RANGE	DEFAULT	NOTES
<b>Configuration</b> ↓ <b>Alarm Configuration</b>	Admin Password level access only	SPT Occupied Alarm Hysteresis	X	2 - 20 ° F	5 ° F	Defines the hysteresis applied above the cooling and below the heating set points before an alarm condition will occur
		SPT Alarm Delay	X	0 - 30 min per degree	10 min	Used to calculate the delay time before an alarm is generated after the alarm condition occurs
		SPT Unoccupied Low Alarm Temperature	X	35 - 90 ° F	45 ° F	Defines the fixed unoccupied low SPT alarm limit
		SPT Unoccupied High Alarm Temperature	X	45 - 100 ° F	95 ° F	Defines the fixed unoccupied high SPT alarm limit
		SAT Low SAT Alarm Limit	X	15 - 90 ° F	45 ° F	Defines the fixed minimum SAT alarm limit
		SAT High SAT Alarm Limit	X	90 - 175 ° F	120 ° F	Defines the fixed maximum SAT alarm limit
		Condensate Overflow Alarm Delay	X	5 - 600 sec	10 sec	Defines the delay time before an alarm is generated after the alarm condition occurs
		Space Humidity Occupied High Alarm Limit	X	45% - 100%	100%	Defines the fixed occupied high space RH alarm limit
		Space Humidity Alarm Delay	X	0 - 30 min per % RH	5 min	Used to calculate the delay time before an alarm is generated after the alarm condition occurs
		Space Humidity Unoccupied High Alarm Limit	X	45% - 100%	100%	Defines the fixed unoccupied high space RH alarm limit
		IAQ/Ventilation Occupied High Alarm Limit	X	0 - 9999 ppm	1100 ppm	Defines the fixed occupied high space IAQ/Ventilation alarm limit
		IAQ/Ventilation Alarm Delay	X	0.1 - 1.0 min per ppm	0.25 min	Used to calculate the delay time before an alarm is generated after the alarm condition occurs
		Rnet Sensor SPT Alarm	X	Ignore/Display	Ignore	Determines if the SPT alarm is displayed on the local Rnet sensor
		Rnet Sensor SAT Alarm	X	Ignore/Display	Ignore	Determines if the SAT alarm is displayed on the local Rnet sensor
		Rnet Sensor Compressor Lockout Alarm	X	Ignore/Display	Display	Determines if the Compressor Lockout alarm is displayed on the local Rnet sensor
		Rnet Sensor Condenser Water Temperature Alarm	X	Ignore/Display	Display	Determines if the Condenser Water Temperature alarm is displayed on the local Rnet sensor
		Rnet Sensor Condensate Overflow Alarm	X	Ignore/Display	Display	Determines if the Condensate Overflow alarm is displayed on the local Rnet sensor
Rnet Sensor Dirty Filter Alarm	X	Ignore/Display	Display	Determines if the Dirty Filter alarm is displayed on the local Rnet sensor		
Rnet Sensor Space High Humidity Alarm	X	Ignore/Display	Ignore	Determines if the High Space RH alarm is displayed on the local Rnet sensor		
<b>Configuration</b> ↓ <b>Linkage</b>		Loop Control Network Number				See TPI
		Loop Control Network Address				See TPI
		Number of Linked Heat Pumps				See TPI

### LEGEND

<b>BAS</b>	— Building Automation System
<b>DCV</b>	— Demand Controlled Ventilation
<b>ECM</b>	— Electronically Commutated Motor
<b>IAQ</b>	— Indoor Air Quality
<b>OAT</b>	— Outdoor Air Temperature
<b>RH</b>	— Relative Humidity
<b>SAT</b>	— Supply Air Temperature
<b>SPT</b>	— Space Temperature
<b>TPI</b>	— Third Party Integration









**50RTP  
START-UP CHECKLIST**

CUSTOMER: \_\_\_\_\_ JOB NAME: \_\_\_\_\_  
MODEL NO.: \_\_\_\_\_ SERIAL NO.: \_\_\_\_\_ DATE: \_\_\_\_\_

**I. PRE-START-UP**

DOES THE UNIT VOLTAGE CORRESPOND WITH THE SUPPLY VOLTAGE AVAILABLE? (Y/N) \_\_\_\_\_

HAVE THE POWER AND CONTROL WIRING CONNECTIONS BEEN MADE AND TERMINALS TIGHT? (Y/N) \_\_\_\_\_

HAVE WATER CONNECTIONS BEEN MADE AND IS FLUID AVAILABLE AT HEAT EXCHANGER? (Y/N) \_\_\_\_\_

HAS PUMP BEEN TURNED ON AND ARE ISOLATION VALVES OPEN? (Y/N) \_\_\_\_\_

HAS CONDENSATE CONNECTION BEEN MADE AND IS A TRAP INSTALLED? (Y/N) \_\_\_\_\_

IS AN AIR FILTER INSTALLED? (Y/N) \_\_\_\_\_

**II. START-UP**

IS FAN OPERATING WHEN COMPRESSOR OPERATES? (Y/N) \_\_\_\_\_

VERIFY PROPER ROTATION OF SCROLL COMPRESSOR PER INSTRUCTIONS. (Y/N) \_\_\_\_\_

**UNIT VOLTAGE — COOLING OPERATION**

PHASE AB VOLTS \_\_\_\_\_ PHASE BC VOLTS \_\_\_\_\_ PHASE CA VOLTS \_\_\_\_\_

PHASE AB AMPS \_\_\_\_\_ PHASE BC AMPS \_\_\_\_\_ PHASE CA AMPS \_\_\_\_\_

**CONTROL VOLTAGE**

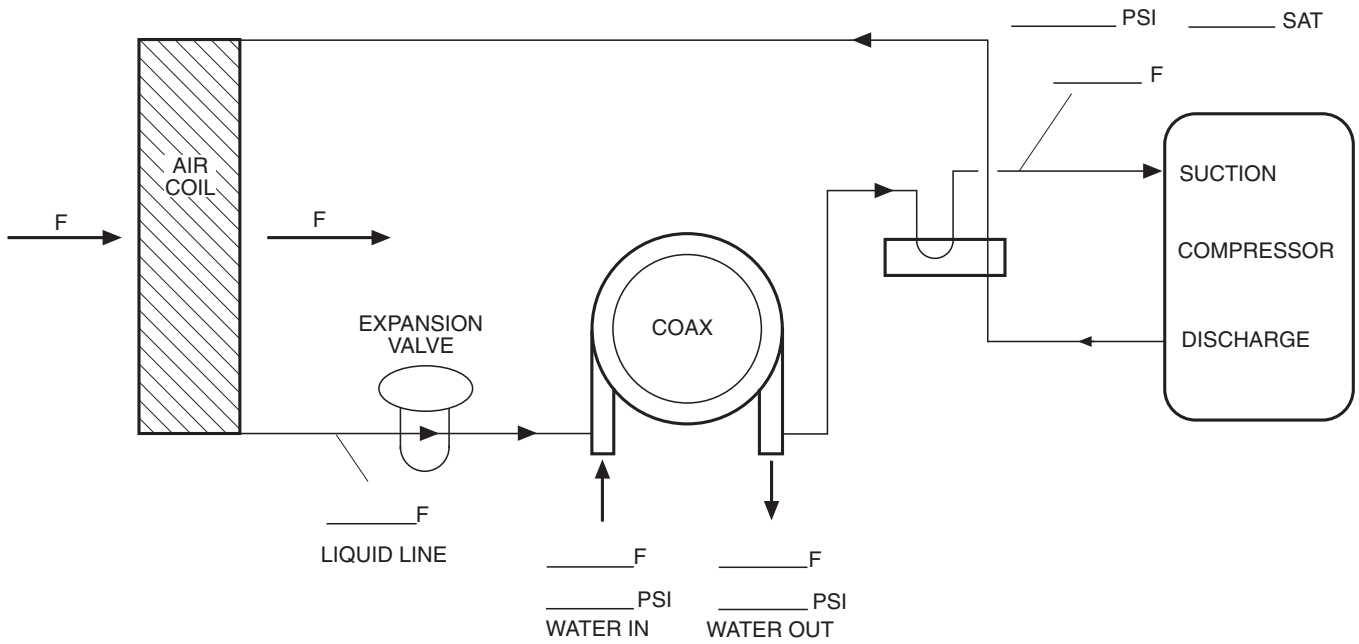
IS CONTROL VOLTAGE ABOVE 21.6 VOLTS? (Y/N) \_\_\_\_\_.  
IF NOT, CHECK FOR PROPER TRANSFORMER CONNECTION.

**TEMPERATURES**

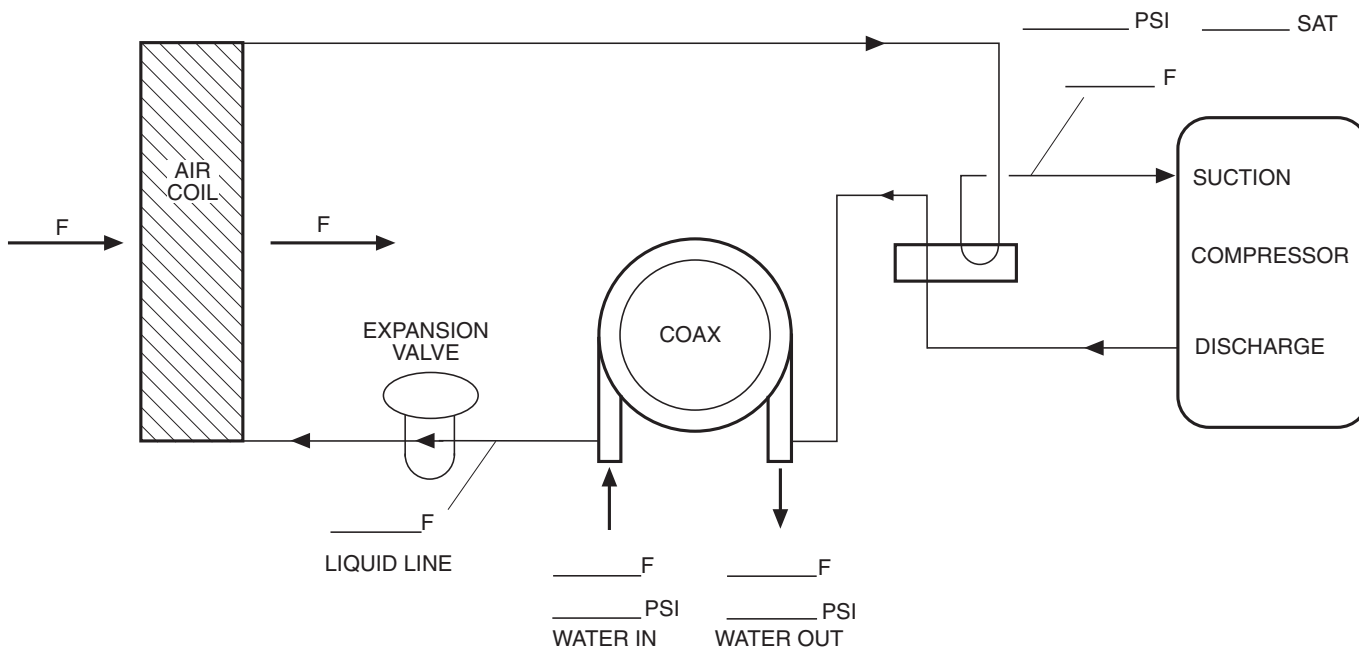
FILL IN THE ANALYSIS CHART ATTACHED.

COAXIAL HEAT EXCHANGER	COOLING CYCLE:	FLUID IN	_____ F	FLUID OUT	_____ F	_____ PSI	_____ FLOW
	HEATING CYCLE:	FLUID IN	_____ F	FLUID OUT	_____ F	_____ PSI	_____ FLOW
AIR COIL	COOLING CYCLE:	AIR IN	_____ F	AIR OUT	_____ F		
	HEATING CYCLE:	AIR IN	_____ F	AIR OUT	_____ F		

# HEATING CYCLE ANALYSIS



# COOLING CYCLE ANALYSIS



**HEAT OF EXTRACTION (ABSORPTION) OR HEAT OF REJECTION =**

$$\text{_____ FLOW RATE (GPM) x _____ TEMP. DIFF. (DEG. F) x _____ FLUID FACTOR* = _____ (Btu/hr)}$$

**SUPERHEAT** = SUCTION TEMPERATURE – SUCTION SATURATION TEMPERATURE  
 = \_\_\_\_\_ (DEG F)

**SUBCOOLING** = DISCHARGE SATURATION TEMPERATURE – LIQUID LINE TEMPERATURE  
 = \_\_\_\_\_ (DEG F)

\*Use 500 for water, 485 for antifreeze.

Copyright 2010 Carrier Corporation

Manufacturer reserves the right to discontinue, or change at any time, specifications or designs without notice and without incurring obligations.  
 Catalog No. 04-53500070-01 Printed in U.S.A. Form 50RTP-1SI Pg CL-2 7-10A 7-10 Replaces: New

CUT ALONG DOTTED LINE

## Free Manuals Download Website

<http://myh66.com>

<http://usermanuals.us>

<http://www.somanuals.com>

<http://www.4manuals.cc>

<http://www.manual-lib.com>

<http://www.404manual.com>

<http://www.luxmanual.com>

<http://aubethermostatmanual.com>

Golf course search by state

<http://golfingnear.com>

Email search by domain

<http://emailbydomain.com>

Auto manuals search

<http://auto.somanuals.com>

TV manuals search

<http://tv.somanuals.com>