

Carrier Air-Cooled Condensing Units

38

Models 38AD,AE,BA
Capacities 92,000 — 978,000 Btuh

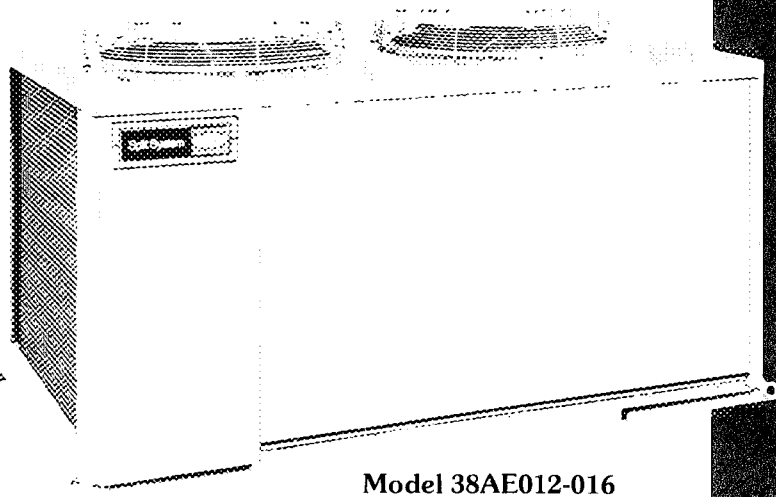

Model 38AE012-016

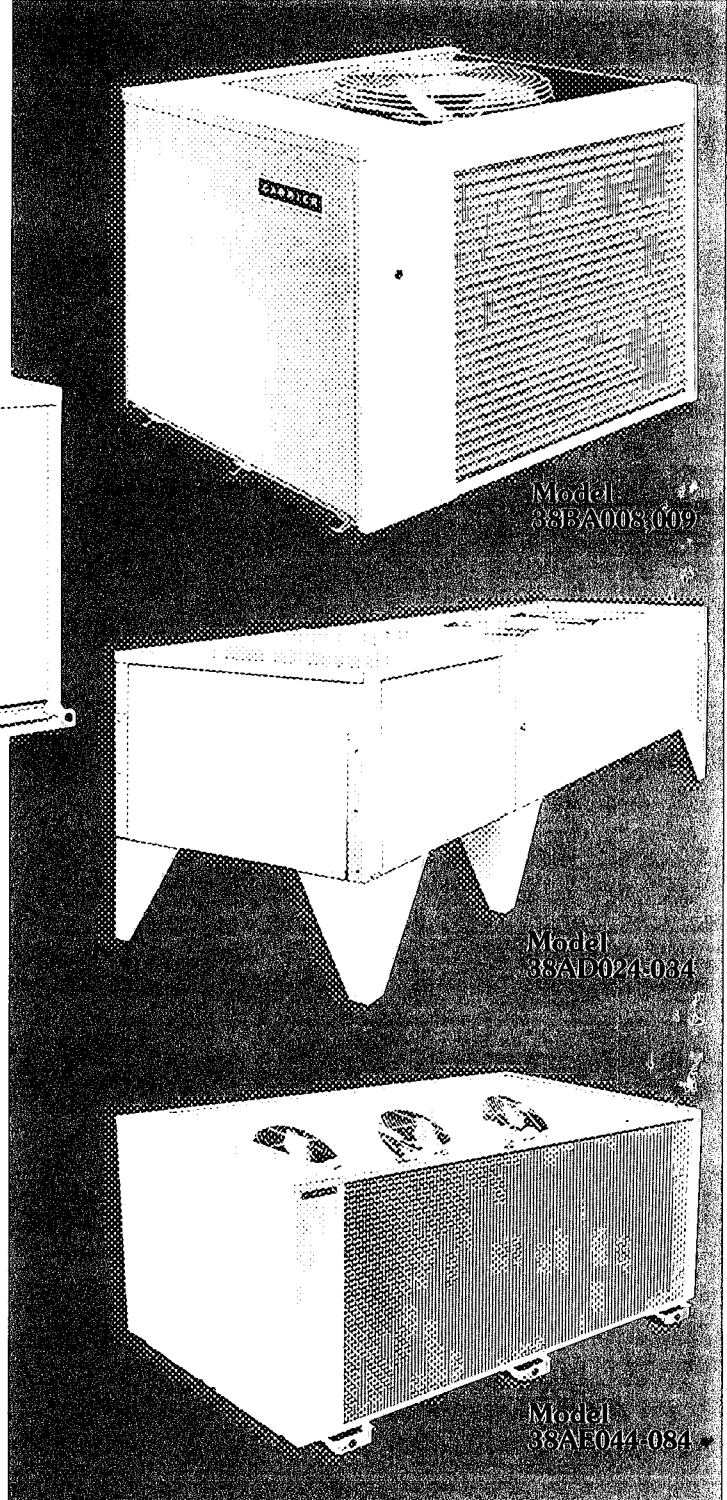

Model 38BA008-009

Model 38AD024-084

Model 38AE044-084

The standout line
of deluxe products
for commercial and
industrial applications



Carrier split systems expertise helps put an effective lid on runaway operating costs.

Specify Carrier deluxe air-cooled condensing units for those commercial and industrial applications where the operating efficiency and initial low-cost advantages of a split system are needed, along with the performance attributes of a built-up system. Matched with a Carrier packaged air handler or indoor coil section, these reliable condensing units provide cost-efficient cooling at a price that won't break your budget. And in these days of increased attention on the whole concept of energy usage, these units are standout performers. With Energy Efficiency Ratios (EER's) to 9.5!

Choose from 3 basic models, 38AD, AE, and BA, in 12 popular sizes covering the capacity range from 92,000 to 978,000 Btuh. Here are some of the quality features Carrier offers to help you keep the lid on runaway operating costs while at the same time delivering year after year of reliable performance you can count on:

High-pressure switch — protects compressor from excessive condensing pressures.

Low-pressure switch — provides loss of charge and evaporator freeze-up protection.

Direct-drive condenser fans — give quiet, dependable operation; superior sound level control because of advanced fan and venturi design concepts.

Crankcase heaters — standard on all models. Helps keep oil in crankcase where it belongs.

Motor protection — includes both temperature and current sensitive devices to prevent failure from electrical overload.

Weather Armor cabinet — weatherproofed for maximum durability, whether units are mounted on the ground or on the roof.

The Deluxe Lineup

38BA	92,000 — 108,000 Btuh
38AE	119,000 — 132,000 Btuh
38AD	252,000 — 371,000 Btuh
38AE	480,000 — 978,000 Btuh

→ **Aluminum fin on copper tube coil construction** — designed for maximum heat transfer and circuited for sub-cooling. Corrosion resistant copper fin/copper tube coils are available.

Head pressure control — is built-in thru fan cycling. In 38AD units (three fans), one fan is cycled by an ambient temperature sensor; a second

fan is cycled by a head pressure sensor. In 38AE units with 2 or 4 fans, fan cycling is controlled by a head pressure sensor. In 6 fan units, 2 fans are cycled by an ambient temperature sensor, and 2 are cycled by a head pressure sensor.

Time-delay and part-winding start control — larger units are equipped with a simple inexpensive means of reducing power demand on start-up and reducing inrush current. On 38AE models with 2 compressors, there is time-delayed start of the second compressor. On Model 38AE084, the second compressor has a time-delay start, with an additional time-delay start for compressor no. 3. On 200/230-volt Models 38AD024-034 and 460-volt Models 38AD028-034, part-winding start control is provided.

Oil-pressure switch — takes the compressor off the line 40 seconds after start-up if oil pressure does not rise to switch setting or if pressure is lost. Manual reset on single compressor Models 38AD and on the lead compressor of Models 38AE044-084.

Solenoid drop relays — are an integral part of the unit controls on Models 38AD and 38AE044-084 to closely monitor solenoid valve operation. On 38AD models, they also allow single pumpout control to evacuate the low side of the system when the system cycles off. As a safety measure, solenoid closes when the compressor trips off.

A tough semihermetic compressor is at the heart of 38 Series condensing units. . .

The compressors used in Carrier air-cooled condensing units are built to exacting standards to deliver outstanding efficiency and overall performance.

Single crankshaft for motor and compressor ends the need for seals, eliminates costly seal leaks, and the expense of shaft realignment often found with open compressors. Crankshaft is polished in both directions to a micro-inch finish. Assures reliability on start-ups, prevents scoring of bearing surfaces.

Vane-type oil pump offers positive oil displacement and is automatically reversible. Needs no breaking in; does not jam.

Oil-pressure regulating valve maintains metered oil pressure to the bearings; keeps bearing wear to a minimum.

Class F rated stator windings enable the motor to withstand higher operating temperatures during locked rotor conditions

Automotive-type compression and oil scraper rings ensure compression and a low rate of oil circulating thru the system, wiping cylinder walls clean of oil, just like in an automobile.

Swedish steel flapper valves have been designed to withstand the stress of prolonged operation. Large port areas for suction and discharge valves decrease gas velocity, minimizing pumping losses, increasing overall efficiency, improving the Btuh/watt ratio (EER).

Pump end bearings are made from permanent mold aluminum castings. Motor end bearing is steel backed, tin base babbitt type.

Piston and connecting rod are composed of a high-density permanent mold aluminum alloy casting, which makes an integral connecting rod bearing.

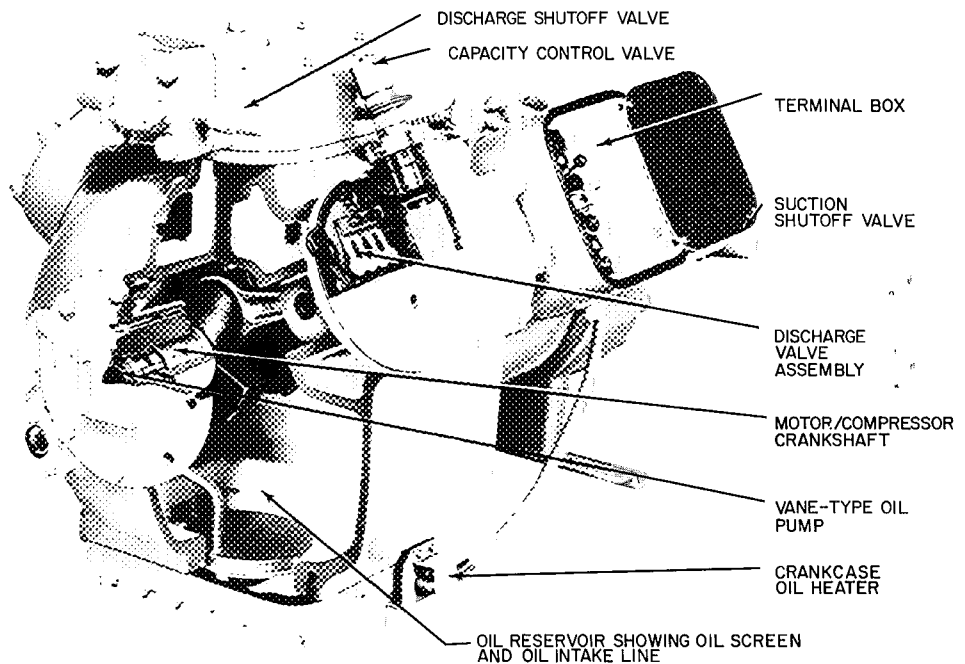

Time Guard® circuit prevents compressor short cycling by requiring a delay of several minutes before compressor can restart after stopping (Models 38AE012-016; 38BA).

Models 38AD024-034, and 38AE044-084 feature a special multifunction Time Guard circuit. This provides approximately a five-minute compressor restart delay, part-winding start of compressors (when offered), bypass of the low-pressure switch at start-up for winter start control, and bypass of the oil-pressure switch at start-up which will shut off the compressor if oil pressure does not reach proper operating level within 40 seconds.

Capacity control device is a bypass type that routes discharge gas back into the suction manifold to unload the compressor to partial capacity (Models 38AE012-016).

Models 38AD024-034 and 38AE044-084 have a suction cut-off type that blocks gas from entering the controlled cylinders when the compressor is unloaded.

Check valve opens to discharge gas into the manifold during loaded operation and closes to isolate the cylinder bank from the manifold during unloaded operation (Models 38AE012-016).

Oil level control orifice or check valve minimizes oil loss from compressor crankcase at start-up. This feature relieves crankcase pressure to the low side and prevents excess oil being pumped out to the high side.

Crankcase heater raises oil temperature during off cycle, reducing refrigerant migration which would dilute the oil and allow it to be pumped away at start-up.

Physical data and dimensions

PHYSICAL DATA 38AD,AE

MODEL	38AE			38AD			38AE								
	012	014	016	024	028	034	044	054	064			084			
OPER WT (lb)	732	779	789	1750	1900	2300	2686	3158	3682			5160			
REFRIGERANT Oper Chg (lb)*	22.0	23.0	23.0	28.0	30.5	35.5	R-22		38	57	81	110			
COMPRESSOR Model(s)	Reciprocating Hermetic, 60-Hz; 1750 Rpm														
	06DD	06DD	06DD	06E4	06E5	06E5	06E4	06EA	06E5	06EA	06E4	06EA	06EA	06E8	06EF
Cylinders	824	328	537	250	265	275	250	250	275	250	275	275	250	275	275
Oil (pt)	6	6	6	4	6	6	4	4	6	4	6	6	4	6	6
	8	8	8	14	19	19	14	14	19	14	19	19	14	19	19
CONDENSER FANS Number	Propeller Type, Direct Drive, Vertical Discharge														
Rpm; 60-Hz	2	2	2	3	3	3	4	6	6	6	6	6	6	6	6
Air Quantity (cfm)	1075	1075	1075	1140	1140	1140	1080	1080	1080	1080	1080	1080	1080	1080	1080
Watts (Total)	8,800	8,800	8,800	18,200	25,200	28,200	26,000	39,000	39,000	39,000	39,000	39,000	39,000	39,000	39,000
Horsepower	1410	1410	1410	3360	4050	4050	2680	4020	4020	4020	4020	4020	4020	4020	4020
	1/2	1/2	1/2	1	1	1	1/2	1/2	1/2	1/2	1/2	1/2	1/2	1/2	1/2
CONDENSER COIL Rows.. Fins/in	2 15	3 15	3 15	3 11 7	3 12 4	3 12 4	3 15 8	2 16 5	3 14 6	3 14 6	3 14 6	3 14 6	3 14 6	3 14 6	3 14 6
Face Area (sq ft)	29.2	29.2	29.2	35.4	39.0	49.6	76.6	114	114	114	114	114	114	114	114
Storage Cap (lb)†	27.2	40.0	40.0	70	77	99	93.7	148.3	222.8	222.8	222.8	222.8	222.8	222.8	222.8
DIMENSIONS (ft-in)															
Length	A 6-4-1/4	6-4-1/4	6-4-1/4	12-10-3/4			11-0-1/4	12-10-9/16			13-8-5/32				
Width	B 3-8	3-8	3-8	3-11-1/2		4-10	7-0-1/2	7-0-1/2		7-0-1/2		7-0-7/16			
Height (Note 2)	C 3-3-7/8	3-3-7/8	3-3-7/8	2-4-1/8		3-1-7/8	4-8-5/32	5-8-1/8		5-8-1/8		7-4-1/8			
Leg Height	D 0-2	0-2	0-2	1-8			0-5	0-5			0-5				
Mounting Holes															
Legs	J —	—	—	0-2-1/2			—	—			—				
	K 6-2-1/4	6-2-1/4	6-2-1/4	3-6-1/4	3-6-1/4	4-4-3/4	7-3-5/32	7-3-5/32		7-3-5/32		7-3-5/32			
	L —	—	—	3-7-3/8			5-6-1/2	8-2		5-3-3/4		5-3-3/4			
	M 3-3-1/2	3-3-1/2	3-3-1/2	8-10			3-5-5/8	2-8-5/16		5-0		5-0			
CONNECTIONS (in)															
Suction	1-1/8	1-3/8	1-3/8	ODM			1-5/8	ODF		ODF		2-5/8			
Liquid	5/8	5/8	5/8	ODM			7/8	ODF		ODF		1-1/8			
Hot Gas Bypass	3/8	3/8	3/8	ODM			5/8	ODF		ODF		7/8			
OPENINGS (in)															
Suction	E 1-3/4	1-3/4	1-3/4	1-3/4			2-1/2	—		—		—			
Liquid	F 1-1/4	1-1/4	1-1/4	1-3/4		1-1/2	1-3/4	—		—		—			
Control	G 7/8	7/8	7/8	7/8			7/8	—		—		—			
Power	H 2	2	2	2			3-5/8	3‡		3-1/2‡		4‡			

*Approximate charge for maximum system capacity. Holding charge is factory supplied with all units.

†Condenser 80% full of liquid R-22 at 125 F for 012,014,016 units and 120 F for all other units.

‡American Standard straight pipe thread.

NOTES:

- All multiple-compressor units have interconnected refrigerant piping.
- Total height for 38AE units; height without legs for all other units.

PHYSICAL DATA 38BA

MODEL	38BA	
	008	009
OPERATING WT (lb)	565	595
REFRIGERANT Operating Chg (lb)*	22	
COMPRESSOR Model(s)	06DA818	06DA824
Cylinders	4	6
Rpm (60-Hz)	1750	1750
Oil Charge (pt)	7	10
CONDENSER FAN Type	Propeller Type, Direct Drive, Vertical	
Air Discharge	Vertical	
Air Quantity (cfm)	5000	5000
Motor Rpm	1075	1075
Watts	660	660
Motor Hp	1/2	1/2
CONDENSER COILS Face Area (sq ft)	14.3 Fins per inch	
Rows	12.46	12.46
	3	3
CONNECTIONS (in.) Suction (ODM) Sweet	1-1/8	1-1/8
Liquid (ODM) Flare	1/2	5/8

*Approximate charge for maximum system capacity when using 25 ft of tubing. Units are factory supplied with approximately 2 lb holding charge.

DIMENSIONS 38BA

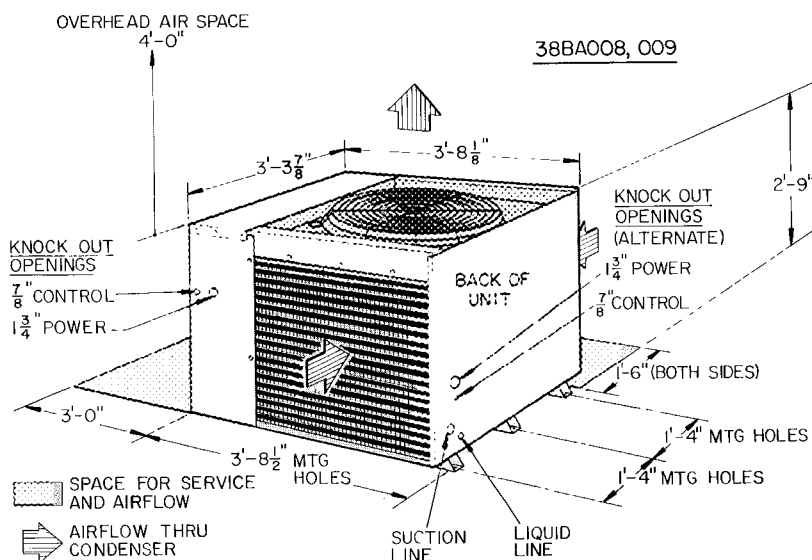

Certified dimension drawings available on request

DIMENSIONS 38AD,AE

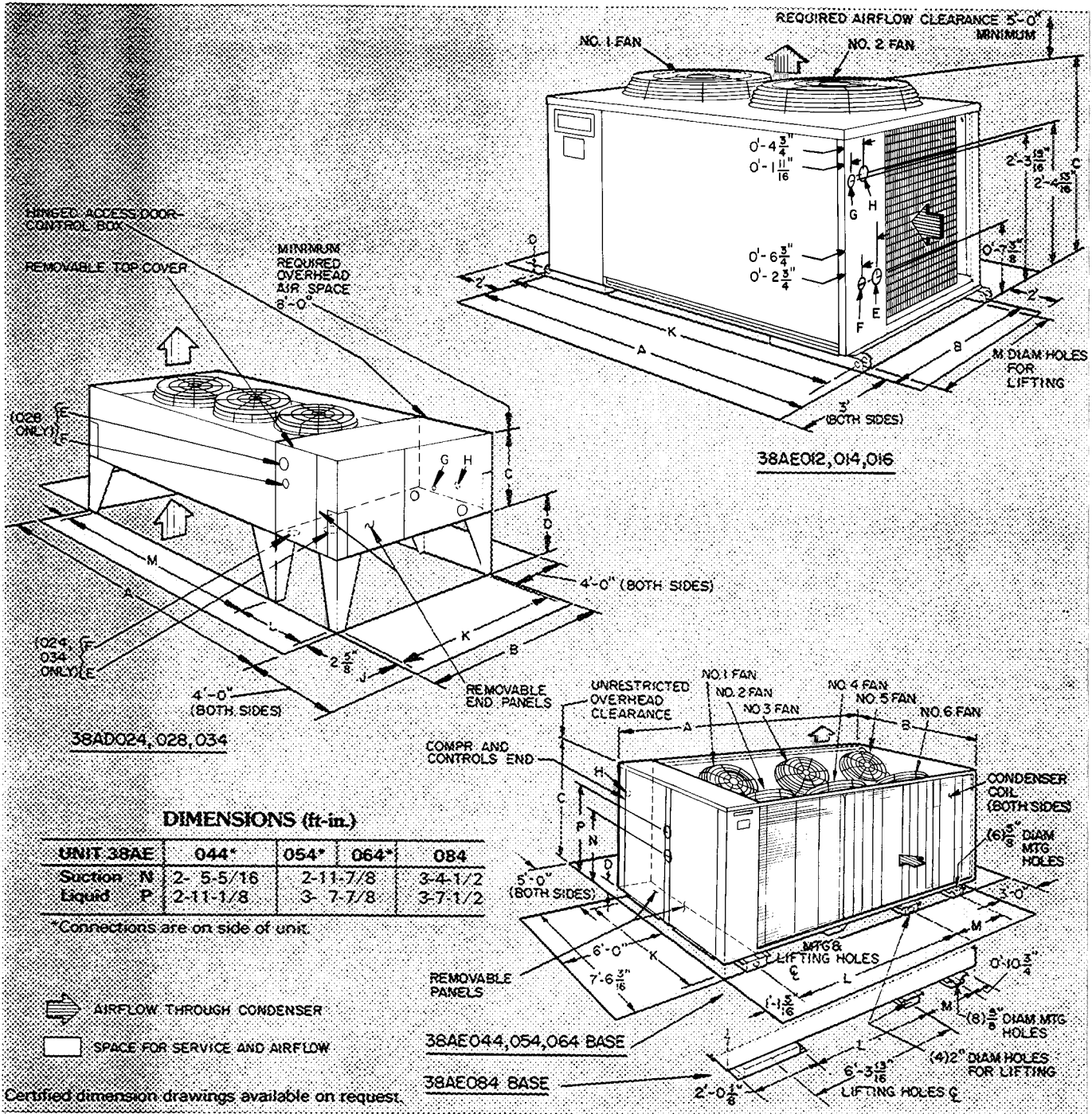

WEIGHT DISTRIBUTION

MODEL 38		Oper Weight	WEIGHT (lb)					
			Support Point					
			A	B	C	D	E	F
AE	012	732	142	138	225	227	—	—
	014	779	143	140	247	249	—	—
	016	789	143	143	250	253	—	—
AD	024	1750	175	175	575	575	125	125
	028	1900	178	178	521	565	207	251
	034	2300	263	263	767	767	120	120
AE	044	2686	906	906	437	437	—	—
	054	3158	1047	1027	542	542	—	—
	064	3682	1174	1174	667	667	—	—
	084	5160	1828	1828	752	752	—	—

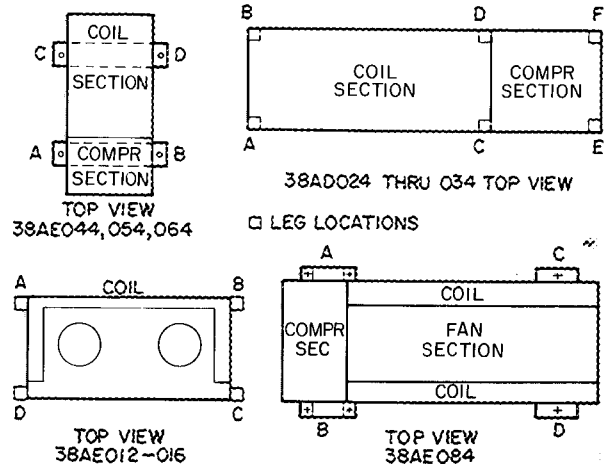

Selection procedure (with example)

I Determine required capacity, saturated suction temperature and temperature of air entering condenser.

Given:

Cooling load 241,000 Btuh
 Saturated suction temperature
 at compressor 30 F
 Temperature air entering condenser 95 F

II Enter Condensing Unit Capacities table at required suction temperature air entering condenser for required capacity. Select a unit that will meet required conditions.

Unit 38AD028 has cooling capacity of 242,000 Btuh at 30 F SST, 118 F SCT and 95 F entering air temperature. Compressor motor power input is 25.4 kw.

Performance data

ARI COMBINATION RATINGS

COND UNIT		COIL OR AIR HANDLER	EVAP AIR (Cfm)	NET SYSTEM CAPACITY (Btuh)	EER
Model	SRN				
38BA 008	20	28CB008	3180	85,000	8.7
		28LA008	3225	86,000	8.9
		40RR008	3300	87,000	9.5
		40BA009	3300	88,000	9.0
		28CB012	3370	90,000	8.9
38BA 009	21	28CB008	3375	98,000	7.9
		28LA008	3375	98,000	7.9
		40RR008	3650	98,000	8.2
		40BA009	3750	100,000	7.6
		28CB012	3860	103,000	7.9
		28LA012	3860	103,000	7.9
38AE 012	22	28LA008	3375	104,000	8.1
		28CB012	4000	110,000	8.3
		28LA012	3900	110,000	8.3
		40RR012	4000	119,000	9.0
		40RR014	4500	121,000	9.3

EER — Energy Efficiency Ratio (Btuh/Watt)

SRN — Sound Rating Number (ARI)

NOTES

- 1 Combination ratings are based on evaporators and condensing units at the same elevation and connected by 25 ft of tubing. If other than 25 ft of tubing is used and/or evaporator is installed above condensing unit, a slight capacity variation may occur.
- 2 Net capacities shown include a deduction for evaporator fan motor heat.
- 3 Direct interpolation is permissible. Do not extrapolate.

Rated in accordance with ARI Standards 210-75 and 270-75



38BA CONDENSING UNIT CAPACITIES (60-Hz)

MODEL	38	SST* (F)	TEMPERATURE AIR ENTERING CONDENSER (F)														
			85			95			100			105			115		
			Cap	SCT	Kw	Cap.	SCT	Kw	Cap.	SCT	Kw	Cap.	SCT	Kw	Cap.	SCT	Kw
BA	008	30	74	110	6.5	69	119	7.0	66	124	7.2	64	128	7.4	58	137	7.9
		35	82	113	6.9	76	122	7.4	72	126	7.6	71	130	7.7	65	139	8.3
		40	90	115	7.4	84	124	7.7	81	128	8.0	78	132	8.2	71	142	8.9
		45	98	118	7.6	92	127	8.1	88	131	8.4	85	135	8.7	78	144	9.3
		50	107	121	7.9	100	129	8.5	96	134	8.9	92	138	9.2	85	147	9.8
BA	009	30	88	117	9.0	81	125	9.5	78	129	9.7	75	133	9.9	68	142	10.3
		35	97	120	9.6	90	128	10.1	85	132	10.4	83	137	10.6	76	145	11.1
		40	106	122	10.1	99	131	10.7	95	135	11.0	91	139	11.2	84	148	11.8
		45	116	125	10.6	108	133	11.3	104	137	11.7	100	142	12.0	92	151	12.5
		50	127	129	11.3	119	138	12.1	113	142	12.4	110	146	12.7	100	154	13.2

38AD,AE CONDENSING UNIT CAPACITIES (60-Hz)

MODEL 38	SST* (F)	TEMPERATURE AIR ENTERING CONDENSER (F)														
		85			95			100			105			115		
		Cap.	SCT	Kw	Cap.	SCT	Kw	Cap.	SCT	Kw	Cap.	SCT	Kw	Cap.	SCT	Kw
012	20	75	107	7.8	66	115	8.3	64	121	8.4	61	125	8.7	56	135	9.0
	25	85	109	8.2	77	117	8.8	75	122	8.9	72	127	9.2	65	136	9.6
	30	96	111	8.7	88	119	9.2	85	124	9.4	82	129	9.8	75	138	10.2
	35	107	113	9.1	99	121	9.7	96	126	10.0	92	131	10.3	85	140	10.8
	40	118	115	9.5	110	124	10.2	106	128	10.5	103	133	10.8	95	142	11.4
	45	129	117	9.9	121	126	10.7	117	130	11.0	113	135	11.4	105	144	12.0
50	140	118	10.4	132	128	11.1	127	132	11.5	123	137	11.9	114	146	12.6	
AE 014	20	88	105	9.2	80	114	9.7	76	119	10.0	73	124	10.3	66	134	10.8
	25	102	107	9.7	93	116	10.3	89	121	10.6	86	126	10.9	79	136	11.5
	30	116	109	10.1	107	119	10.9	102	123	11.2	98	128	11.5	91	138	12.1
	35	130	111	10.6	120	121	11.4	116	125	11.7	111	130	12.1	103	140	12.8
	40	144	114	11.1	134	123	12.0	129	128	12.3	124	132	12.8	115	142	13.5
	45	158	116	11.6	148	125	12.5	142	130	12.9	137	134	13.4	127	144	14.2
50	172	118	12.1	161	127	13.1	156	132	13.5	150	136	14.0	139	146	14.9	
016	20	113	110	12.5	103	120	13.1	98	124	13.5	92	129	13.8	83	138	14.2
	25	129	113	13.4	119	122	14.1	114	127	14.4	108	132	14.8	98	141	15.4
	30	146	116	14.2	135	125	15.1	130	129	15.4	124	134	15.8	113	143	16.4
	35	163	118	15.1	151	128	16.0	145	132	16.4	139	137	16.8	128	146	17.6
	40	179	121	16.0	167	130	16.9	161	135	17.4	155	139	17.9	143	148	18.7
	45	196	124	16.8	183	133	17.9	177	137	18.4	171	142	18.9	158	151	19.8
50	213	126	17.7	200	135	18.9	193	140	19.4	186	145	19.9	173	154	20.9	
024	20	168	105	16.2	154	114	16.9	148	119	17.3	142	123	17.6	130	132	18.2
	25	185	107	17.2	171	116	18.1	164	121	18.5	157	125	18.8	144	134	19.6
	30	205	109	18.3	189	118	19.2	182	123	19.7	175	127	20.1	160	136	20.9
	35	226	112	19.3	209	120	20.4	201	125	20.9	193	129	21.4	178	138	22.3
	40	248	114	20.4	230	123	21.5	222	127	22.1	213	131	22.7	196	140	23.7
	45	271	117	21.5	252	125	22.7	243	129	23.3	234	134	24.0	216	142	25.1
50	295	119	22.6	275	128	23.9	265	132	24.6	256	136	25.3	236	145	26.5	
AD 028	20	213	105	21.6	198	114	22.2	190	119	22.7	183	123	22.9	169	132	23.0
	25	236	107	22.8	219	116	23.2	211	121	24.3	203	126	24.4	188	134	24.7
	30	260	109	24.3	242	118	25.4	233	123	25.8	225	127	26.0	207	136	26.4
	35	285	111	25.2	266	120	26.9	256	125	27.2	247	129	27.6	228	138	28.1
	40	311	114	26.8	290	123	28.3	279	127	28.7	270	131	29.1	249	140	30.0
	45	337	116	27.8	315	125	29.6	304	129	30.4	293	134	30.9	272	142	31.9
50	363	118	29.1	340	127	30.7	328	131	31.6	318	136	32.4	295	144	33.9	
034	20	245	103	24.2	225	112	25.2	215	117	25.8	206	122	26.3	188	131	27.2
	25	271	105	25.7	249	114	26.9	239	119	27.5	229	123	28.1	210	132	29.2
	30	300	107	27.2	277	116	28.5	266	120	29.2	255	125	29.9	233	134	31.2
	35	331	109	28.7	306	118	30.2	294	122	31.0	283	127	31.8	260	136	33.2
	40	364	111	30.2	338	120	31.9	325	125	32.8	312	129	33.6	287	138	35.3
	45	399	114	31.8	371	122	33.6	357	127	34.5	344	131	35.5	317	140	37.3
50	435	116	33.3	405	125	35.3	390	129	36.3	376	133	37.3	347	142	39.3	
044	20	317	106	33.1	291	115	34.4	278	120	35.0	266	124	35.6	241	134	36.7
	25	352	108	35.0	325	117	36.4	312	121	37.1	299	126	37.8	273	135	39.1
	30	390	110	36.8	361	119	38.5	347	123	39.3	333	127	40.0	306	137	41.6
	35	429	112	38.8	399	121	40.6	384	125	41.5	369	129	42.4	340	138	44.3
	40	470	115	40.8	439	123	42.8	423	127	43.9	407	132	44.9	377	140	47.0
	45	514	117	42.8	480	125	45.1	463	130	46.3	447	134	47.5	415	142	49.9
50	558	120	45.0	522	128	47.5	505	132	48.8	488	136	50.2	454	145	53.0	
AE 054	20	393	106	40.3	363	116	41.7	348	120	42.4	334	125	43.1	305	135	44.4
	25	437	108	42.4	405	117	44.2	389	122	45.0	374	126	45.8	344	136	47.5
	30	483	110	44.7	450	119	46.7	433	123	47.7	417	128	48.7	385	137	50.7
	35	533	112	47.0	497	121	49.3	480	125	50.4	462	130	51.6	427	139	54.0
	40	585	114	49.4	547	123	52.0	528	127	53.3	510	132	54.6	472	141	57.3
	45	640	117	51.9	600	125	54.8	579	130	56.3	559	134	57.7	518	143	60.8
50	699	119	54.5	654	128	57.7	632	132	59.3	610	136	60.9	565	145	64.3	
064	20	469	105	47.0	435	115	48.6	418	119	49.4	401	124	50.1	369	134	51.7
	25	520	107	49.6	484	116	51.5	467	121	52.4	450	126	53.4	415	135	55.3
	30	574	109	52.2	537	118	54.5	519	123	55.6	501	127	56.7	464	136	59.1
	35	631	111	55.0	592	120	57.6	573	125	58.9	554	129	60.2	514	138	63.0
	40	693	114	57.8	651	122	60.8	631	127	62.3	610	131	63.8	566	140	67.0
	45	758	116	60.8	713	125	64.1	691	129	65.8	667	133	67.5	619	142	71.0
50	827	119	63.9	777	127	67.6	753	132	69.5	727	136	71.3	674	144	75.1	
084	20	619	109	64.6	571	119	67.4	546	125	68.9	522	130	70.0	476	140	72.1
	25	699	110	68.1	648	120	71.3	621	125	72.9	595	130	74.3	545	140	76.8
	30	778	111	71.7	724	121	75.2	696	125	76.9	668	130	78.5	614	140	81.5
	35	863	114	75.7	806	123	79.6	777	127	81.5	747	132	83.2	690	142	86.6
	40	948	116	79.8	888	125	84.0	858	129	86.0	825	134	87.9	765	143	91.6
	45	1042	119	84.3	978	128	88.7	945	132	90.9	911	137	93.1	847	146	97.1
50	1136	122	88.8	1068	130	93.5	1031	134	95.9	997	139	98.3	929	148	102.7	

Cap. — Capacity (1000 Btu/h)
 Kw — Compressor Motor Power Input at Rated Voltage
 SCT — Saturated Condensing Temperature
 SST — Saturated Suction Temperature

*Saturated Suction Temperatures (SST) shown correspond to pressures at compressor Actual suction temperature is higher due to superheat

NOTES

- 1 Performance data is with Refrigerant 22
- 2 Contact local Carrier representative for condensing unit capacities with R-502 at low suction temperatures required for refrigeration duty
- 3 Do not extrapolate Interpolation is permissible
- 4 Assume 15 F subcooling when selecting TXV
- 5 Refer to Combination Rating sheets and System Data Digests for ratings with air handlers and water coolers

Electrical data

ELECTRICAL DATA (60-Hz)

MODEL 38	UNIT				EACH COMPRESSOR				FAN MOTORS							
	Nameplate Voltage	Voltage Range	MCA	MOCP*	RLA		LRA		Total Fans	FLA (ea)		Kw				
					No. 1	No. 2	No. 1	No. 2		No. 1	No. 2					
BA	008	208/230	187-253	42.7	50	31.3	137	1	3.6	—	660					
		460	414-528	19.4	30	14.1	62					1.8	—	660		
		575	518-660	16.4	25	10.2	50					3.6	—	660		
BA	009	208/230	187-253	53.1	70	39.6	170	1	3.6	—	660					
		460	414-528	24.1	40	17.8	77					1.8	—	660		
		575	518-660	20.9	40	13.8	62					3.6	—	660		
AE	012	208/230	187-253	62.5	100	43.6	170	2	4.3	3.7	1.41					
		460	414-528	29.1	40	20.0	77					2.3	1.9	1.41		
		575	518-660	22.8	35	15.7	62					1.8	1.8	1.41		
AE	014	208/230	187-253	69.3	100	49.3	191	2	4.3	3.7	1.41					
		460	414-528	31.7	50	22.1	80					2.3	1.9	1.41		
		575	518-660	25.6	40	17.9	69					1.8	1.8	1.41		
AE	016	208/230	187-253	87.5	125	63.6	266	2	4.3	3.7	1.41					
		460	414-528	40.7	60	29.3	120					2.3	1.9	1.41		
		575	518-660	33.0	50	23.8	96					1.8	1.8	1.41		
AD	024	208/230	187-253	103	175	76.0	345	3	4.5	4.6	3.36					
		460	414-508	51	80	36.0	173					1.9	1.9	3.36		
		575	518-632	41	60	28.6	120					1.6	1.6	3.36		
AD	028	208/230	187-253	145	225	100.0	446	3	6.2	6.6	4.05					
		460	414-508	69	110	48.0	223					3.0	3.0	4.05		
		575	518-632	62	100	43.4	164					2.5	2.5	4.05		
AD	034	208/230	187-253	170	275	120.0	506	3	6.2	6.6	4.05					
		460	414-508	72	110	50.0	253					3.0	3.0	4.05		
		575	518-632	64	100	45.0	176					2.4	2.4	4.05		
AE	044	208/230	187-253	187	250	No. 1	No. 2	4	No. 1 & 2	No. 3,4,5,6†	2.68					
		460	414-508	89	125	76.0	345					4.6	4.6	2.68		
		575	518-632	74	80	36.0	173					2.3	2.3	2.68		
AE	054	208/230	187-253	241	350	119.0	76.0	6	4.6	4.6	4.02					
		460	414-508	111	150	53.0	36.0					2.3	2.3	4.02		
		575	518-632	93	100	45.0	30.0					1.8	1.8	4.02		
AE	064	208/230	187-253	284	400	119.0	506	6	4.6	4.6	4.02					
		460	414-508	128	175	53.0	253					2.3	2.3	4.02		
		575	518-632	108	125	45.0	176					1.8	1.8	4.02		
AE	084	208/230	187-253	371	450	No. 1	No. 2 & 3	6	6.2	7.7	7.98					
		460	414-508	167	200	76.0	119.0					345	506	3.3	3.3	7.98
		575	518-632	141	150	30.0	53.0					173	253	2.6	2.6	7.98

Amp draw at 230 volts. The units have a 575- to 230-volt transformer and use a 230-volt motor.

- FLA** — Full Load Amps, for fan motors
- Kw** — Total Kilowatts
- LRA** — Locked Rotor Amps
- MCA** — Minimum Circuit Amps. Complies with National Electrical Code (NEC), Section 430-24
- MOCP** — Maximum Overcurrent Protection
- RLA** — Rated Load Amps, for compressor motors
- Voltage Range** — Units are suitable for use on electrical systems where voltage supplied to unit terminals is not below or above listed range limits. Maximum allowable voltage unbalance between phases is 2%.

*Fuse only

†Only No. 3 and 4 on 38AE044

NOTES:

- 1 On 38AE084 units, the center compressor is No. 1, the left is No. 2 and the right is No. 3, viewed from the compressor end of the unit. On all other 38AE units, the left compressor is No. 1 and the right is No. 2, viewed from compressor end.
- 2 On 38AD units, No. 1 fan is adjacent to the compressor compartment; on 38AE units, No. 1 and 2 fans are in this location.
- 3 Speed control fan motors for Motormaster® application. 38BA008,009 — standard on 200-, 230-, 460-volt units. 38AE012,014,016 (No. 1 fan) — standard on 208-230-, 460-volt units. All other 38AD (No. 1 fan) — standard on 200-, 230-volt units; special on 460-volt units. All 38AE (No. 1 & 2 fans) — standard on 200-, 230-, 460-volt units.

Accessory control wiring

DEFROST THERMOSTAT, 24-VOLT RELAY PACKAGE AND REMOTE CONTROL CENTER FOR 38AE044-084 UNITS

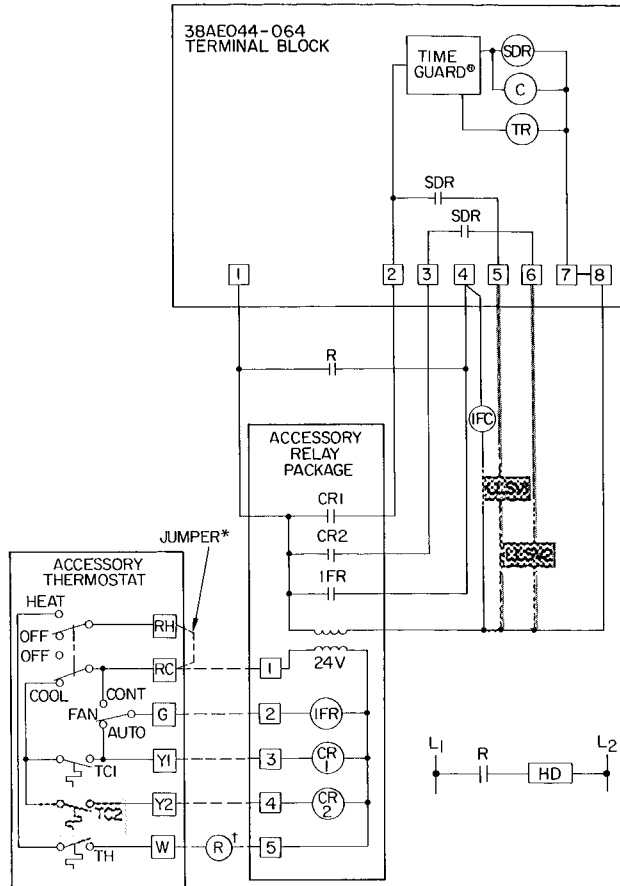

When interconnecting piping is *under* 125 feet:
 One-step cooling — no LLSV is required
 Two-step cooling — only LLSV1 is required

When interconnecting piping is *over* 125 feet:
 Both LLSV1 and LLSV2 are required
 For one-step cooling, wiring must be changed to control both LLSV1 and LLSV2 thru TC1

ACCESSORY CONTROL WIRING — 38BA008,009

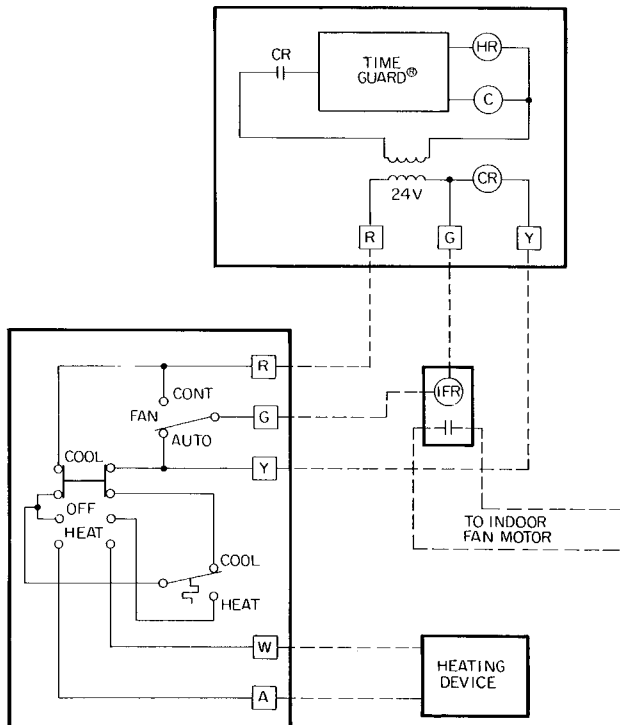

ACCESSORY THERMOSTAT WIRING, 38AE012-016 UNITS

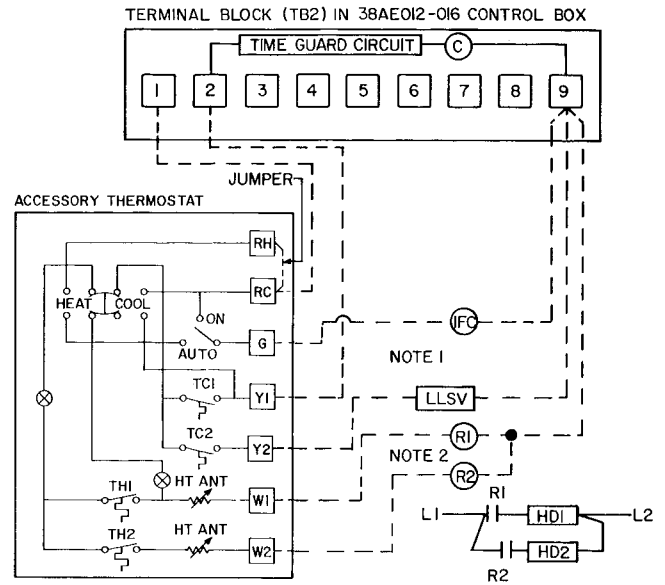

- NOTES:
- 1 Combination LLSV plus IFC VA should not exceed 30 VA
 - 2 Do not exceed 5 VA (24 VAC) per coil
- Use accessory relay-transformer package 38AE900001 if these VA values must be exceeded

DEFROST THERMOSTAT, 24-VOLT RELAY PACKAGE AND REMOTE CONTROL CENTER FOR 38AD UNITS

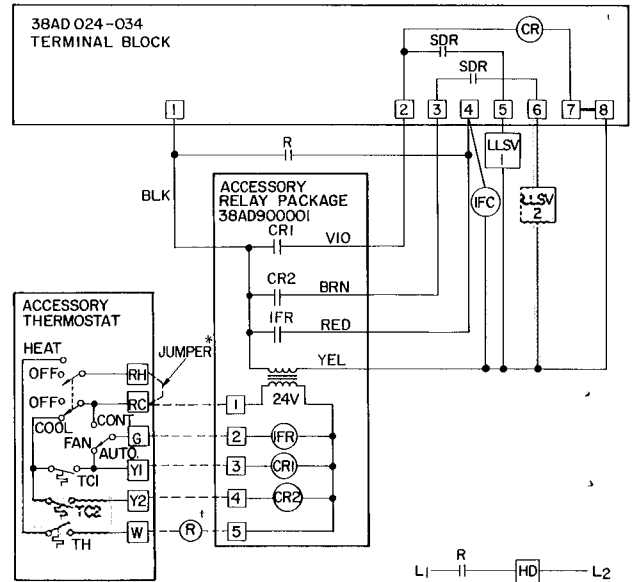

LEGEND AND NOTES FOR ELECTRICAL DIAGRAMS

- | | |
|---|----------------------------------|
| C — Compressor Contactor | SDR — Solenoid Drop Relay |
| CR — Control Relay | TC — Thermostat, Cooling |
| HD — Heating Device | TH — Thermostat, Heating |
| HR — Holding Relay | TR — Timer Relay |
| IFC — Indoor Fan Contactor | Trans — Transformer |
| IFR — Indoor Fan Relay | |
| LLSV — Liquid Line Solenoid Valve | ——— Factory Wiring |
| R — Heat Control Relay (field-supplied, 24-volt sealed coil, 10-va max rating) | - - - - - Field Wiring |

Omit on one-step cooling

*Jumper removed only when separate 24-volt power sources are available for heating and cooling
 †To control heating device and provide automatic indoor fan operation on heating (2-pole, field supplied)

NOTE: Wiring diagrams are general guides only and are not intended for a specific installation. Refer to individual product Installation, Start-Up, and Wiring literature

Typical piping and wiring

Accessories

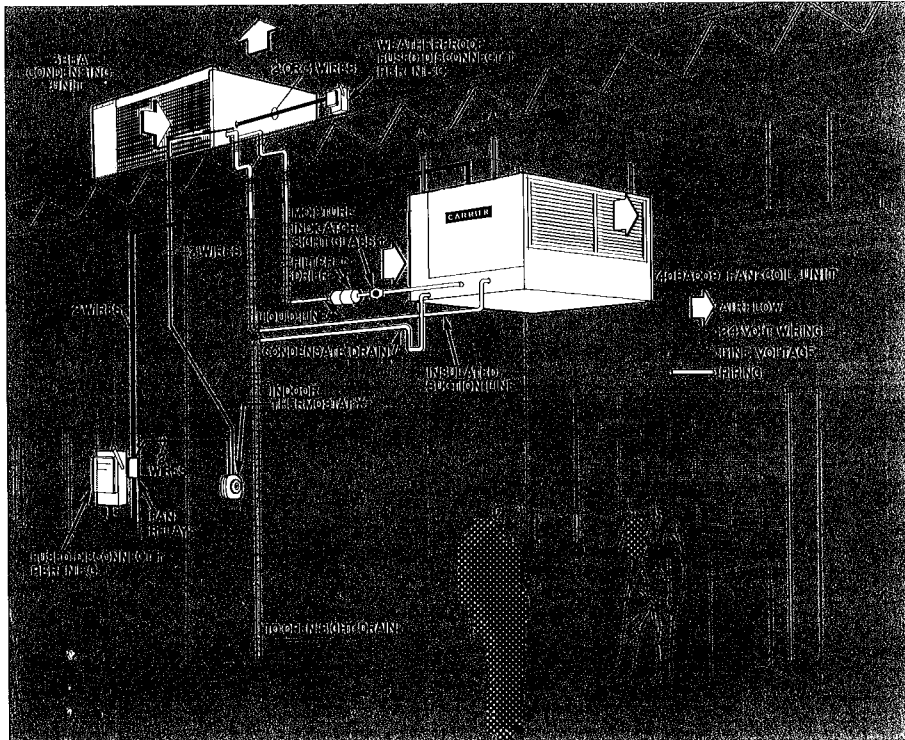

*Accessory item
†Field supplied

NOTES

- 1 All piping must follow standard refrigerant piping techniques Refer to Carrier System Design Manual for details
- 2 All wiring must comply with the applicable local and national codes
- 3 Wiring and piping shown are general points-of-connection guides only and are not intended for or to include all details for a specific installation

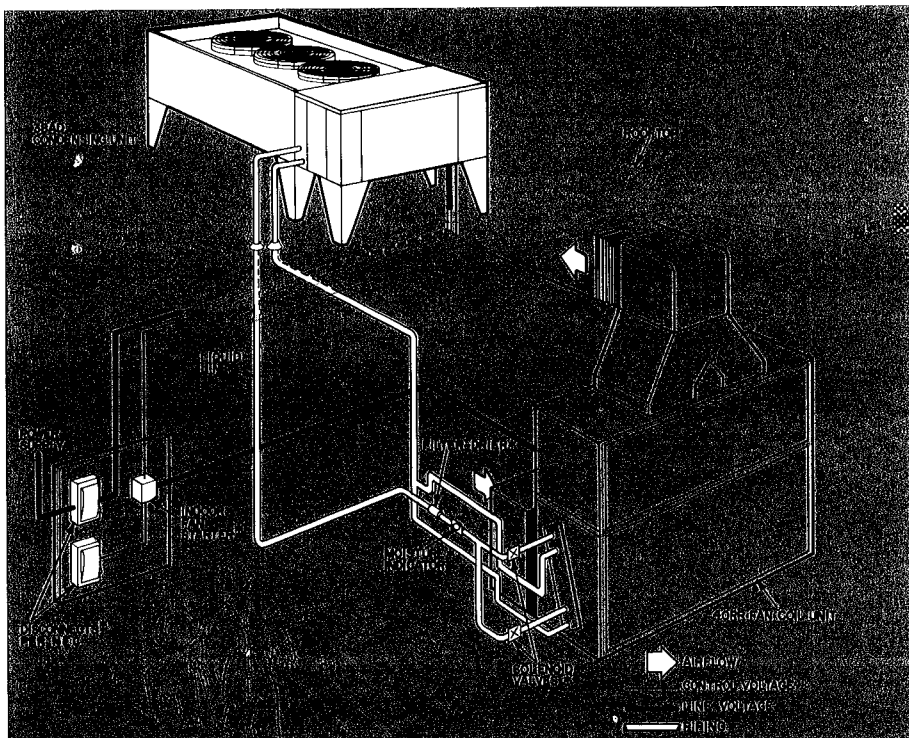

*Field supplied

NOTE This illustration is only one example of 38AD/40RR unit connections and not intended to be used as a guideline for system hookups Refer to the 38AD/40RR Installation Instructions for preferred piping techniques

- **Electric unloaders**, when coupled with appropriate remote sensors, react quickly to the smallest temperature variation for maximum energy savings.

- **Pressure operated unloader** provides additional step of capacity for Models 38AE012, 38AE014, 38AE016 and 38AE064. Includes cylinder head, valve plate, unloader valve, and hardware.

- **Remote control center and switch base** (24 volt) for thermostatic control of unit from conditioned space. Single-stage, heating-cooling or two-stage heating, single-stage cooling models are available. Allows selection of heating and cooling; allows continuous or cycling operation of indoor fan.

- **Indoor fan relay** controls indoor unit fan motor.

- **Evaporator defrost thermostat package** may be used with winter start control. Contains thermostat, enclosure and necessary wiring and hardware.

- **Low Voltage Relay Package**, a fan relay, support relays, terminal block and enclosure. (Standard in Model 38BA.)

- **The 32LT Motormaster® control** is a solid-state device which measures the saturated condensing temperature of the system and controls the RMS power flow to fan motor. The airflow varies with the fan speed, keeping the condensing temperature and head pressure constant.

- **Gage panel**

- • **Hot gas bypass package** (38AD024-034 and 38AE044-064).

- **Coil grille packages** (38AE012-016 and 38BA008,009).

- **Winter start package** (38AE012-016).

- **Relay transformer package** (38AE012-016).

Application

Indoor installations

1. Unit (except Model 38AE044 thru 084) may be installed indoors with ducted condenser air when suitable outdoor location is not available. Condenser fan may be operated against an external static pressure up to 0.2 in. wg. There will be approximately a 1% decrease in capacity at 0.1 in. wg and 3% decrease at 0.2 in. wg.
2. Do not install unit indoors when air entering condenser will exceed 110 F.
3. Standard installation procedures should be followed with regard to ductwork, insulation and vibration isolation. Ducts should be arranged to prevent recirculation of condenser air.

Use of liquid line solenoid valves

- 38BA008,009; 38AE012 thru 016: liquid line solenoid valves not required for single evaporator coil applications.
- 38AE012 thru 016 dual coil applications: single liquid line solenoid required to deactivate upper second-stage coil.
- 38AD024 thru 034: liquid line solenoid valves required for each evaporator coil stage

38AE044 thru 084 may require liquid line solenoid valves in two types of applications. In installations requiring 125 ft or more of interconnecting piping, solenoid valves are required on all coil splits to be operated by the solenoid drop relay that is installed in the unit. In installations where the compressors are able to unload to a very low percentage of full load, it is usually necessary to install liquid line solenoid valves on one or more of the coil splits to assure sufficient refrigerant velocity in the coil to return oil to the compressor.

The 38AD024 thru 034 units are wired for single pumpout control. Field-supplied liquid line solenoid valve(s) is required to restrict the flow of refrigerant to the evaporator during the off cycle. When the thermostat is satisfied, the liquid line solenoid valve(s) will close. The unit, however, will continue to run, evacuating the low side, until the low pressurestat opens.

The 38BA008,009, 38AE012-016, and 38AE044-064 do not require single pumpout control or a liquid line solenoid drop when the unit is de-energized unless the interconnecting piping exceeds 100 ft (125 ft in the Model 38AE).

Field-supplied liquid line solenoid valves are required on units with multiple evaporators to deactivate upper portion of evaporator coil surface in order to unload compressor (suction-activated unloaders) at part-load conditions and provide single pumpout control when last solenoid drops. *Pumpdown control is not recommended.*

Solenoid drop protection (liquid line solenoid valve closes, compressor shuts off and crankcase heaters energize simultaneously) is recommended for Series 10 cooling applications. Single pumpout is not recommended for Series 10 cooler applications because of possible damage due to frost pinching of cooler tubes.

Oil return

Condensing units with multiple-step unloading *may require double suction risers* to assure proper oil return at minimum load operating conditions. Reduction of evaporator coil surface should be analyzed to provide sufficient refrigerant velocity to return oil to the compressor. Liquid line solenoid valves may be used in certain situations to accomplish this. Bypass hot gas, if used, should be introduced before the evaporator. Consult Carrier System Design Manual.

MINIMUM OUTDOOR AIR OPERATING TEMPERATURE

MODEL 38		NO. OF CYL	% FULL LOAD CAP.	MINIMUM OUTDOOR OPER TEMP (F)*	
				DX Evaporator(s)	
				Single	Multiple
BA	008	4	100	55	55
	009	6	100	50	50
AE	012	6	100	35	35
		4	67	45	55
		2†	33	55	75
	014	6	100	37	37
		4	67	48	58
		2†	33	57	77
016	6	100	23	23	
	4	67	36	46	
	2†	33	50	70	
AD	024	4	100	0	0
		2	50	20	30
	028 and 034	6	100	15	15
		4	67	30	40
		2	33	45	65
		044	8	100	38
6	75		41	51	
4	50		44	54	
2	25		57	77	
AE	054	10	100	14	14
		8	80	29	29
		6	60	34	44
		4	40	40	60
		2	20	47	67
		2	20	47	67
	064	12	100	14	14
		10	83	17	17
		8†	67	32	42
		6	50	32	42
		4	33	45	65
		2†	17	58	78
084	16	100	14	14	
	14	88	15	15	
	10	63	33	43	
	8	50	32	42	
	4	25	46	66	
	4	25	46	66	

*With accessory 32 Series Motormaster® head pressure control units can operate to -20 F ambient

†Requires accessory pressure-operated unloader package

NOTES

- 1 Minimum outdoor air operating temperatures for single DX evaporator based on



On application with multiple DX evaporators, the compressor may be unloaded while an individual coil(s) is still fully loaded. For proper expansion valve operation under this condition, a 90 F condensing temperature must be maintained by observing the minimum ambient under the Multiple DX Evaporator(s) column.

- 2 Winter start operation is standard on 38AD024 thru 034 and 38AE044 thru 084 units and built into the control circuit. The low-pressure switch is automatically bypassed for 2-1/2 minutes on start-up; no liquid line low-pressure switch is required. Field-fabricated wind baffles are required on all 38AE units.
- 3 For winter start operation on 38AE012 thru 016 units, use accessory package 38AE900021.
- 4 For winter start operation on 38BA008 and 009 units, relocate the low pressurestat connection to the connection on the liquid line service valve. Field-fabricated wind baffles are required.
- 5 For evaporator freeze-up protection on 38BA units, add thermostat (Carrier Part 50BB900001) to indoor coil.

Application (cont)

LIQUID LINE DATA

MODEL 38		MAX ALLOW LIQUID LIFT (ft)*
BA	008	60
	009	45
AE	012	52
	014	67
	016	82
AD	024	84
	028	64
	034	46
AE	044	73
	054	38
	064	56
	084	52

*Based on a 2 F liquid line loss and a 7 psi pressure loss for accessories

Guide specifications

Furnish and install an air-cooled condensing unit in the location and manner shown on the plan. The unit shall be properly assembled and tested at the factory. It shall be designed for use with Refrigerant 22.

Nominal unit electrical characteristics shall be _____ volts, 3-phase, _____-Hertz. The unit shall be capable of satisfactory operation within voltage limits of _____ volts to _____ volts.

Performance — Capacity shall be _____ Btuh or greater, with air entering condenser at _____ F, and a saturated suction temperature at compressor of _____ F. Saturated condensing temperature shall not exceed _____ F. Maximum liquid lift shall be _____ feet.

→ The unit shall operate down to _____ F outdoor air temperature entering condenser with standard controls and down to _____ F outdoor air temperature with addition of Solid-State Motormaster® Head Pressure Controller.

Condenser coil shall be of nonferrous construction. Coil shall have aluminum plate fins, mechanically bonded to seamless copper tubes. Coil shall be circuited for subcooling.

Condenser fans and motors — Unit shall be furnished with _____ direct-driven, propeller-type fans arranged for vertical discharge. Condenser fan motors shall have inherent protection, and shall be of the permanently lubricated type, resiliently mounted. Each fan shall have a safety guard. Controls shall be included for cycling fan(s) for intermediate season operation.

Compressor(s) — Unit shall have _____ compressors. Each shall be of serviceable hermetic design with external spring isolators and shall have an automatically reversible oil pump. Maximum power input to compressor shall not

be more than _____ kw at conditions specified.

Compressor shall unload in response to suction pressure down to _____ % of full capacity in _____ steps for partial load operation. Compressor shall be located in a section separated from condenser fans and coil.

Multiple compressor units shall have step-start fans and coils. Compressor motor(s) shall have (part-winding start), (across-the-line start).

Controls shall be factory wired and located in a separate enclosure. Safety devices shall consist of high- and low-pressure switches and compressor overload devices. Unit wiring shall incorporate a positive acting timer to prevent short cycling of compressor if power is interrupted. Timer shall prevent compressor from restarting for approximately 5 minutes after shutoff.

The 460- and 575-volt 38BA units shall have a transformer for the 230-volt control circuit. All 38AD and 38AE044-084 units, for all voltages, shall have a transformer for the 115-volt control circuit. The 38AE012-016 units shall have transformer for 24-volt control circuit for all voltages.

Casing shall make unit fully weatherproof for outdoor installation. Casing shall be of galvanized steel, zinc phosphatized and finished with baked enamel.

Openings shall be provided for power and refrigerant connections. Panel shall be removable to provide access for servicing.

Connections — Only one liquid line, one suction line and one power supply connection shall be required for each unit.

Dimensions of entire assembly shall be not more than _____ in. high, _____ in. long and _____ in. wide.

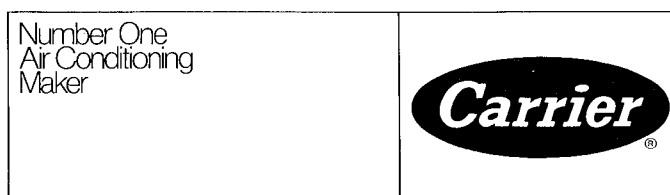

Carrier Parkway • Syracuse, N.Y. 13221

Manufacturer reserves the right to discontinue, or change at any time, specifications or designs without notice and without incurring obligations.

Book	1	2	4
Tab	3a	1a	2a

Form 38AE-4P Supersedes 38AE-3P

Printed in U S A

1285

9-81

PC 111

Catalog No 523-893

Free Manuals Download Website

<http://myh66.com>

<http://usermanuals.us>

<http://www.somanuals.com>

<http://www.4manuals.cc>

<http://www.manual-lib.com>

<http://www.404manual.com>

<http://www.luxmanual.com>

<http://aubethermostatmanual.com>

Golf course search by state

<http://golfingnear.com>

Email search by domain

<http://emailbydomain.com>

Auto manuals search

<http://auto.somanuals.com>

TV manuals search

<http://tv.somanuals.com>