

RTU Open

Installation and Start-up Guide

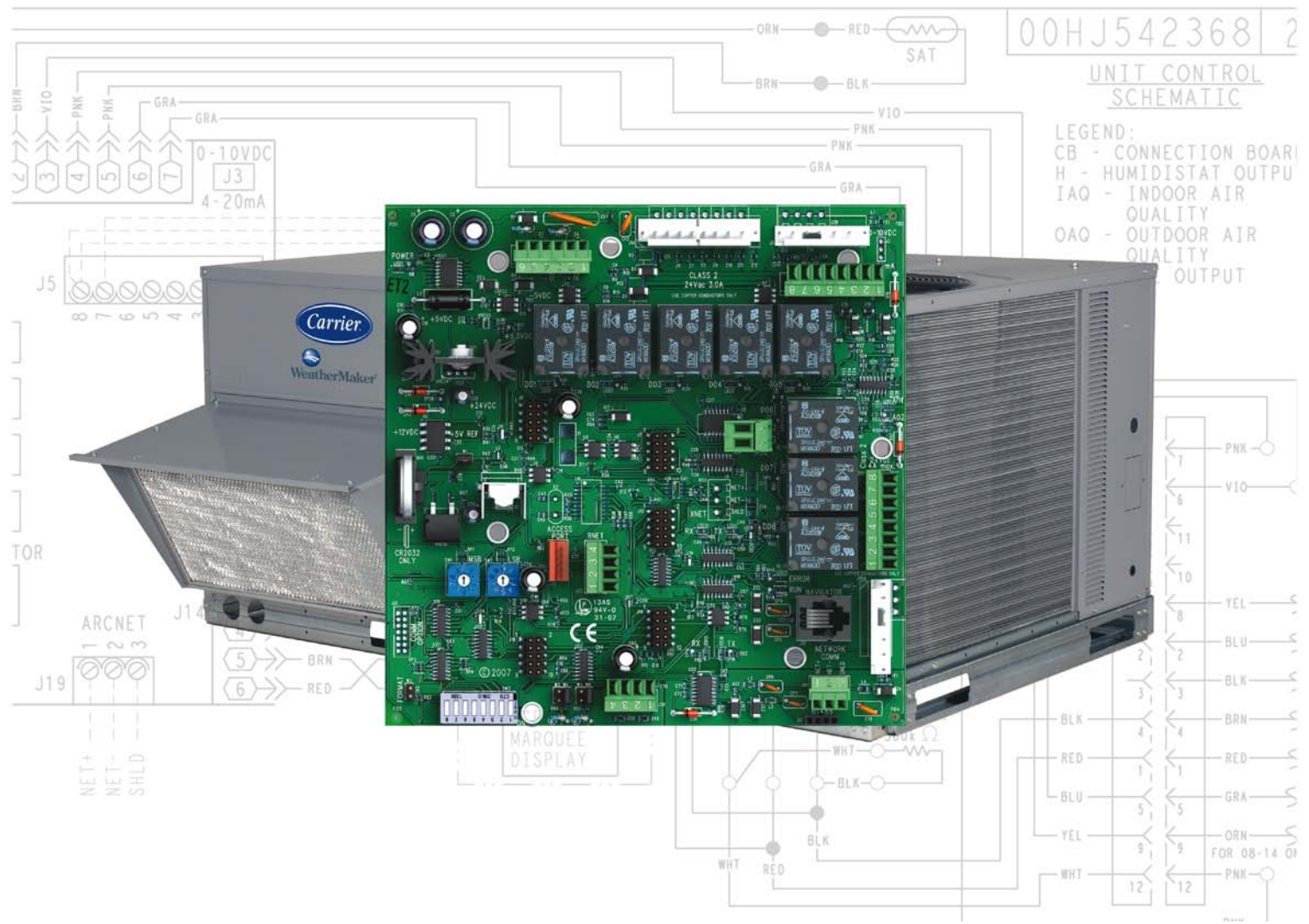

Table of Contents

Introduction.....	1
What is the RTU Open controller?	1
Specifications	3
Safety considerations.....	4
Installation	5
Field-supplied hardware	5
To mount the RTU Open.....	6
To wire the controller for power.....	7
Using the rooftop equipment control power transformer	7
Using an auxiliary control power transformer.....	8
To set the RTU Open's address.....	9
To set the RTU Open's communications protocol and baud rate.....	10
Wiring the RTU Open to the MS/TP network.....	10
Wiring specifications	11
To wire the controller to the network	11
Wiring inputs and outputs	12
Input wiring specifications	13
Inputs	13
Binary outputs	14
Analog output	14
To wire inputs and outputs	14
Wiring sensors to inputs	18
Field-supplied sensor hardware	19
Wiring an SPT sensor	20
Rnet wiring specifications.....	20
To wire the SPT sensor to the controller	21
Wiring a Supply Air Temperature sensor.....	21
Wiring specifications	22
To wire the SAT sensor to the controller	22
Wiring a Duct Air Temperature sensor	22
Wiring specifications	22
To wire a duct sensor to the controller	23
Wiring an Outdoor Air Temperature sensor	23
Wiring specifications	23
To wire an OAT sensor to the controller	23
Wiring a CO2 sensor.....	24
Wiring specifications	24
To wire the CO2 sensor to the controller	24
Wiring an Outdoor Air Quality sensor	25
Wiring specifications	26
To wire the OAQ sensor to the controller	26
Wiring a Relative Humidity sensor	26
Wiring specifications	27
To wire the RH sensor to the controller.....	27
Wiring a Humidistat.....	27
Wiring specifications	27
To wire a humidistat to the controller	28
Wiring an enthalpy switch	28
Wiring specifications	28
To wire an enthalpy switch (outdoor air) to the controller	29
To wire an enthalpy switch (differential) to the controller.....	30

Wiring a status switch	31
Wiring specifications	31
To wire a status switch to the controller	32
Wiring a compressor safety	32
Wiring specifications	32
To wire a compressor safety input to the controller	33
Wiring an occupancy switch or door contact	33
Wiring specifications	33
To wire an occupancy switch or door contact	34
Start-up	35
Service Test	36
Configuring the RTU Open's properties	37
Unit Configuration properties	37
Setpoint properties	39
Service Configuration properties	40
Sequence of Operation	42
Occupancy	42
Supply fan	43
Cooling	43
Economizer	44
Power Exhaust	44
Unoccupied Free Cooling	45
Optimal Start	45
Enthalpy control	46
Indoor Air CO2	46
Heating	47
Heat Pump operation	48
Dehumidification	48
Demand Limit	49
Door switch	49
Remote occupancy	49
Fire Shutdown	49
Compressor Safety	49
Fan Status	50
Filter Status	50
Alarms	50
Linkage	53
Linkage Air Source Modes	54
Troubleshooting	55
Serial number	55
LED's	55
Replacing the RTU Open's battery	56
Compliance	57
FCC Compliance	57
CE Compliance	57
BACnet Compliance	57
Appendix A: RTU Open Points/Properties	58
Status	58
Unit Configuration	59
Setpoints	61
Alarm Configuration	65
Service Configuration	66
Maintenance	68
Alarms	70

Linkage.....	71
I/O Points.....	71
Appendix B: Single Point Linkage and Device Address Binding.....	73
Single Point Linkage	73
Device Address Binding.....	74
Index.....	75

Introduction

What is the RTU Open controller?

The RTU Open controller is available as an integrated component of a Carrier rooftop unit, or as a field-installed retrofit product. Its internal application programming provides optimum rooftop performance and energy efficiency. RTU Open enables the unit to run in 100% stand-alone control mode or it can communicate to the Building Automation System (BAS).

On board DIP switches allow you to select the baud rate and choose one of the following protocols:

- BACnet
- Modbus
- Johnson N2
- LonWorks

Carrier's diagnostic display tools such as BACview⁶ Handheld or Virtual BACview can be used with the RTU Open controller via the **J12** Access Port. See illustration on the following page.

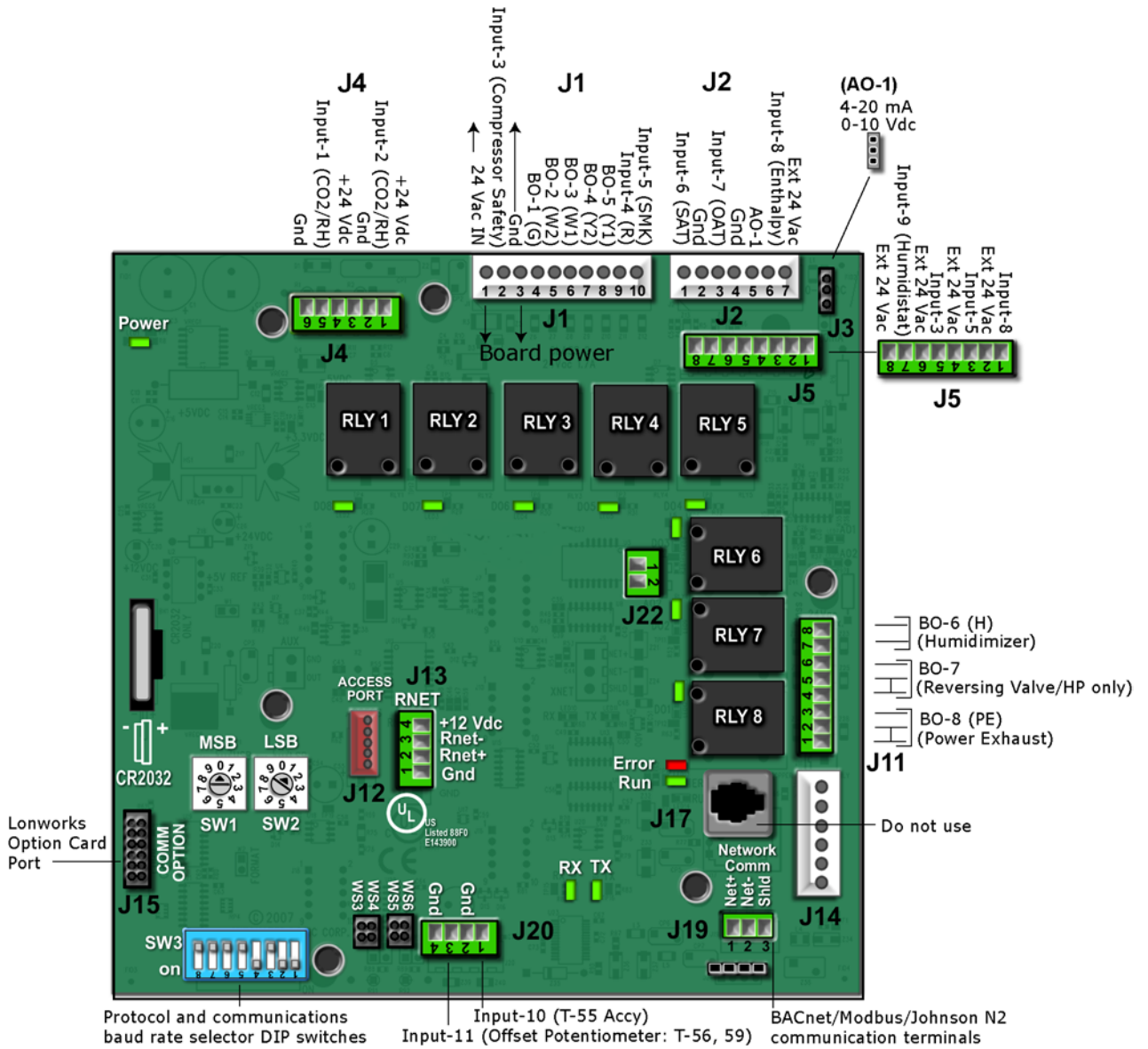

Specifications

RTU Open driver	drv_rtuopn_std
Power	24 Vac $\pm 10\%$, 50–60 Hz 20 VA power consumption (26 VA with BACview attached) 26 Vdc (25 V min, 30 V max) Single Class 2 source only, 100 VA or less
Access port J12	To connect a BACview ⁶ Handheld, Virtual BACview, or Field Assistant
Rnet port J13	For SPT sensors and a BACview ⁶ in any of the following combinations, wired in a daisy-chain configuration: <ul style="list-style-type: none"> • 1 SPT Plus or SPT Pro • 1–4 SPT Standards • 1–4 SPT Standards, and 1 SPT Plus or SPT Pro Any of the above combinations, plus a BACview ⁶ , but no more than 6 devices total
Comm Option port	For communication with the LonWorks Option Card.
Inputs	12 inputs: <p>Inputs 1 - 2: 4-20 mA only</p> <p>Inputs 3, 5, 8, 9: Binary, 24 Vac</p> <p>Inputs 6 - 7: Thermistor</p> <p>Inputs 10 - 11: Thermistor</p> <p>Rnet sensor</p>
Binary outputs	8 relay outputs, contacts rated at 3 A max @ 24 Vac Configured normally open.
Analog output	1 analog output AO1: 2 - 10 Vdc or 4-20 mA
Output resolution	10 bit D/A
Real-time clock	Battery-backed real-time clock keeps track of time in event of power failure
Battery	10-year Lithium CR2032 battery provides a minimum of 10,000 hours of data retention during power outages
Protection	Incoming power and network connections are protected by non-replaceable internal solid-state polyswitches that reset themselves when the condition that causes a fault returns to normal. The power, network, and output connections are also protected against voltage transient and surge events.
Status indicators	LED's indicate status of communications, running, errors, power, and digital outputs
Environmental operating range	-40 to 158 °F (-40 to 70 °C), 10–95% relative humidity, non-condensing NOTE Controllers should be mounted in a protective enclosure. Vibration during operation: all planes/directions, 1.5G @ 20–300 Hz Shock during operation: all planes/directions, 5G peak, 11 ms Shock during storage: all planes/directions, 100G peak, 11 ms

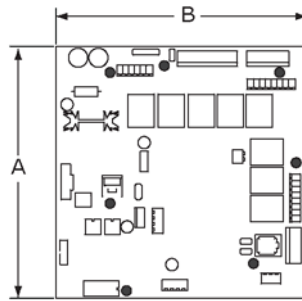

Overall dimensions	A: 6-1/2 in. (16.5 cm) B: 6-1/2 in. (16.5 cm)
Mounting dimensions	7 mounting holes in various positions
Panel depth	2-1/2 in. (6.4 cm)
Weight	11.2 oz (0.32 kg)
BACnet support	Conforms to the Advanced Application Controller (B-AAC) Standard Device Profile as defined in ANSI/ASHRAE Standard 135-2004 (BACnet) Annex L
Listed by	UL-873, FCC Part 15-Subpart B-Class A, CE EN50082-1997

Safety considerations

Warning!

Disconnect electrical power to the RTU Open before wiring it. Failure to follow this warning could cause electrical shock, personal injury, or damage to the controller.

Installation

To install the RTU Open:

- 1 *Mount the controller (page 6).*
- 2 *Wire the controller for power (page 7).*
 - *Using the rooftop equipment control power transformer (page 7).*
 - *Using an auxiliary control power transformer (page 8).*
- 3 *Set the controller's address (page 9).*
- 4 *Wire inputs and outputs (page 12).*
- 5 *Wire sensors to the controller (page 18).*

Field-supplied hardware

An RTU Open retrofit installation may require the following field-supplied components:

- wiring harness: Part #OPN-RTUHRN
- transformer – 24 Vac, 20 VA minimum
- wiring

Application-dependent components:

- carbon dioxide sensors
- damper/damper actuator
- differential pressure switch
- enthalpy switch
- fan status switch
- door switch
- fan section door switch
- relative humidity sensor
- remote occupancy contact
- smoke detector
- temperature sensors

To mount the RTU Open

Warning!

When you handle the RTU Open:

- Do not contaminate the printed circuit board with fingerprints, moisture, or any foreign material.
- Do not touch components or leads.
- Handle the board by its edges.
- Isolate from high voltage or electrostatic discharge.
- Ensure that you are properly grounded.

Warning!

When you mount the RTU Open:

- Do not locate in an area that is exposed to moisture, vibration, dust, or foreign material.
- Follow NEC and local electrical codes.
- Do not obstruct access for unit maintenance.
- Protect from impact or contact during unit maintenance.

We highly recommend that you mount the RTU Open in the unit control panel!

Screw the RTU Open into an enclosed panel using the mounting slots on the cover plate. Leave about 2 in. (5 cm) on each side of the controller for wiring.

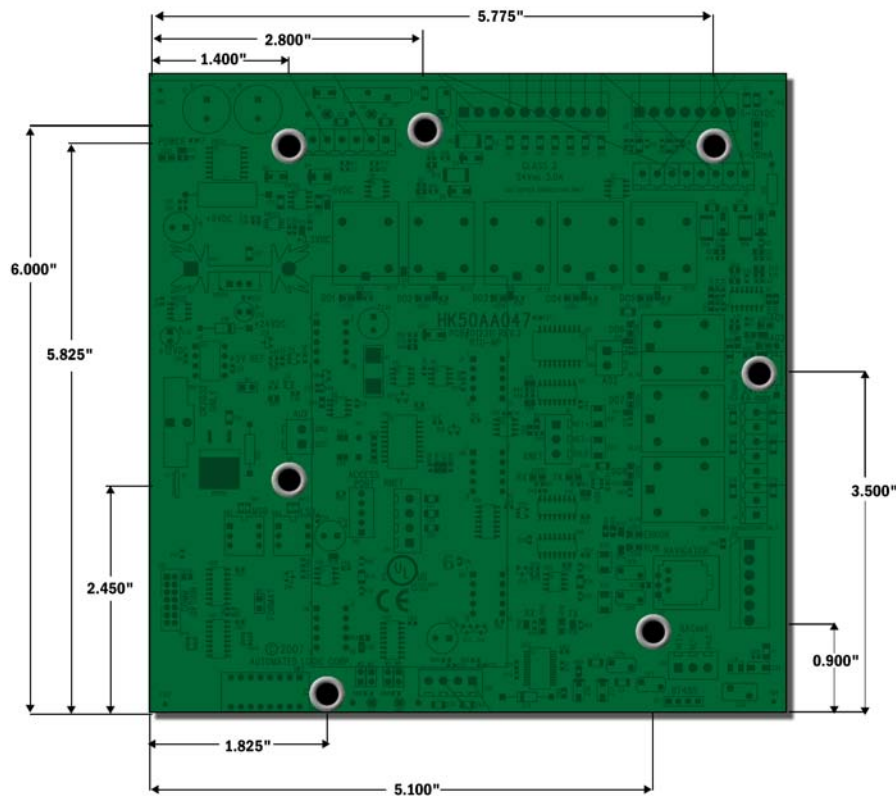

To wire the controller for power



CAUTIONS

- The RTU Open is powered by a Class 2 power source. Take appropriate isolation measures when mounting it in a control panel where non-Class 2 circuits are present.
- Do not power pilot relays from the same transformer that powers the RTU Open.
- In most cases, the RTU Open will be powered from the control power transformer provided with the rooftop equipment. If you must use a separate control power transformer, additional precautions must be taken to ensure that the auxiliary transformer is in-phase with the rooftop equipment's control power transformer. See *Using an auxiliary control power transformer* (page 8).

Using the rooftop equipment control power transformer

- 1 Remove power from the 24 Vac transformer.
- 2 Remove connector assembly from RTU Open's **J1** connector.

- 3 If the rooftop equipment has thermostat connection terminals, connect wiring harness **J1** wire 1 to R, and **J1** wire 3 to C. Alternately, connect the control power transformer wires to **J1** connector wires 1 (24 Vac) and 3 (Gnd).
- 4 Apply power to the rooftop equipment.
- 5 Measure the voltage at the RTU Open's **J1** terminals 1 and 3 to verify that the voltage is within the operating range of 21.6–26.4 Vac.
- 6 Attach harness to RTU Open connector **J1**.
NOTE The harness and connector are keyed and must be oriented properly for correct installation.
- 7 Verify that the **Power** LED is on and the **Run** LED is blinking.

Using an auxiliary control power transformer

If you use a separate control power transformer, it is essential that the auxiliary transformer and the rooftop transformer are in-phase. You **must** verify this prior to connecting the auxiliary transformer to the RTU Open.

Follow these steps:

- 1 Verify the available primary voltage at the rooftop equipment.
- 2 Remove power from the rooftop equipment and install the appropriate auxiliary transformer. Follow the manufacturer's installation instructions.
- 3 Ground one leg of the auxiliary transformer's secondary wiring.
- 4 Apply power to the rooftop equipment. Measure the potential between the rooftop equipment control power and auxiliary transformer's secondary hot (non-grounded) legs. If the voltage measured is less than 5 volts, the transformers are in-phase; proceed to step 7. If you measure a voltage greater than 24 Vac, then the phases are reversed.
- 5 Correct the phase reversal by either of the following methods:
 - Remove the ground from the secondary at the auxiliary transformer and connect it to the other secondary
 - Reverse the primary wiring at the auxiliary transformer
- 6 Repeat step 4 to rewire.
- 7 Remove connector assembly from RTU Open's **J1** connector.
- 8 Connect the auxiliary transformer wires to **J1** wires **1** (24 Vac) and **3** (Gnd).
- 9 Apply power to the transformer.
- 10 Measure the voltage at the RTU Open's **J1 - 1** and **3** to verify that the voltage is within the operating range of 21.6–26.4 Vac.
- 11 Attach harness to RTU Open's connector **J1**. See illustration below.
NOTE The harness connectors are keyed and must be oriented properly for correct installation.
- 12 Verify that the **Power** LED is on and the **Run** LED is blinking.

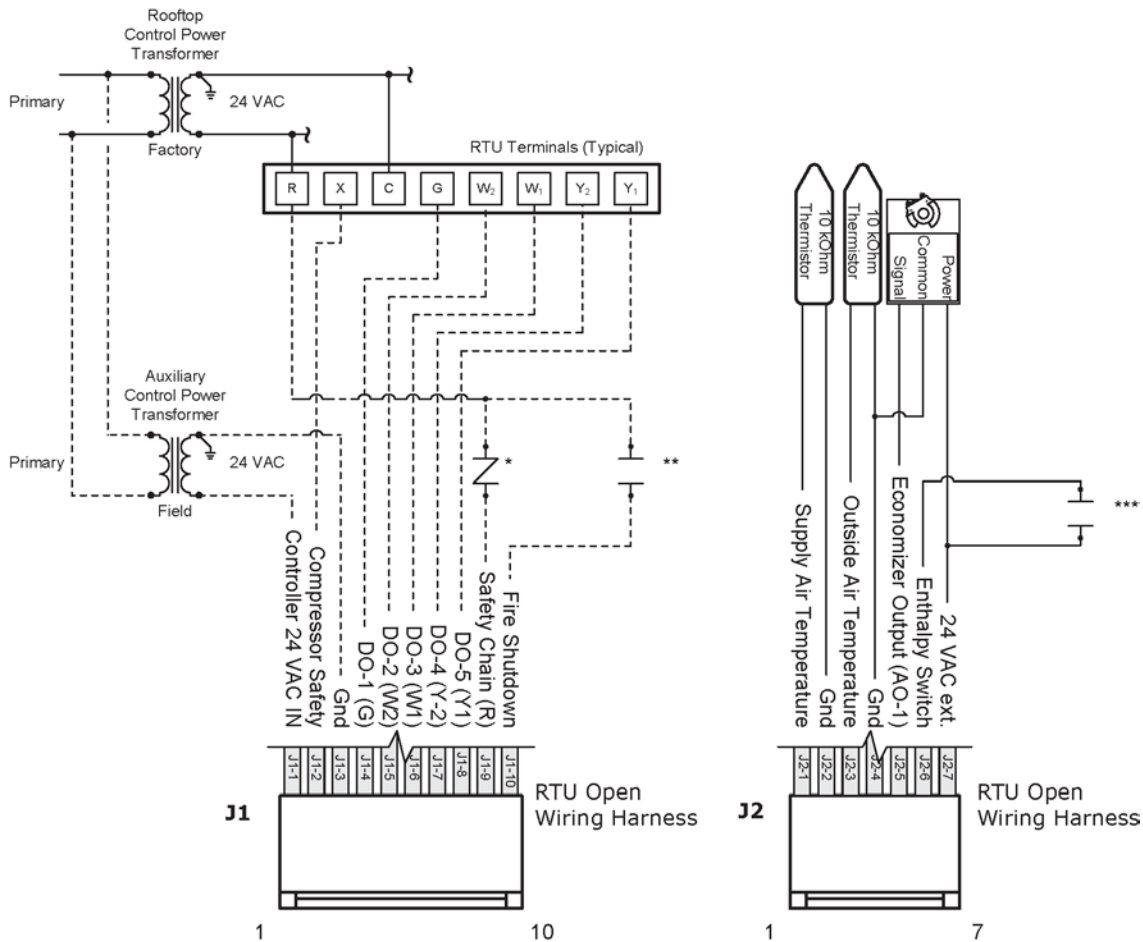

Optional

- * Safety chain devices, field-installed - normally closed. Apply 24 Vac to this terminal (jumper from **J1** - 1 to **J1** - 9) where no safety devices are installed.
- ** Fire shutdown device, field-installed, configurable as normally open or closed
- *** Enthalpy switch, field-installed - configurable as normally open or closed

To set the RTU Open's address

The RTU Open's two rotary switches determine the RTU Open's MAC address when it is placed on an MS/TP network. The rotary switches define the MAC address portion of the RTU Open's BACnet device instance number, which is composed of the MS/TP network number and the MAC address. They also set the slave address on a Modbus or N2 network when less than 100. See the *RTU Open Integration Guide* for additional information on integration.

CAUTION The MAC address of the controller must be unique on its network.

- 1 Turn **off** the RTU Open's power. The controller reads the address each time you apply power to it.
- 2 Using the rotary switches, set the **MSB (SW1) (10's)** switch to the tens digit of the address, and set the **LSB (SW2) (1's)** switch to the ones digit.

EXAMPLE To set the RTU Open's address to 01, point the arrow on the **MSB (SW1)** switch to 0 and the arrow on the **LSB (SW2)** switch to 1.

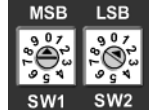

- 3 Turn on the RTU Open's power.

NOTE The factory default setting is "00" and must be changed to successfully install your RTU Open.

To set the RTU Open's communications protocol and baud rate

RTU Open's **SW3** DIP switches are used to set the controller's protocol and baud rate. The protocol and speed selection is determined by the network on which the controller will be installed. For Carrier BACnet implementations, select MS/TP @ 76.8 k as follows:

- 1 Power down the RTU Open. The controller reads the protocol and baud rate each time you apply power to it.
- 2 Set **SW3** DIP switches 1, 2, and 4 to **On** to configure the controller for BACnet MS/TP and 76.8 k baud.

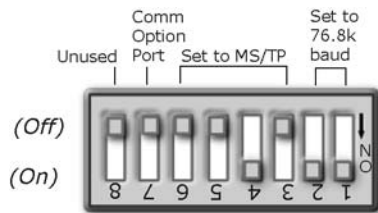

- 3 Power up the RTU Open.

NOTE Other protocols and baud rates are available. See the *RTU Open Integration Guide* for additional instructions.

Wiring the RTU Open to the MS/TP network

The RTU Open communicates using BACnet on an MS/TP network segment communications at 9600 bps, 19.2 kbps, 38.4 kbps, or 76.8 kbps.

Wire the controllers on an MS/TP network segment in a daisy-chain configuration.

Install a BT485 on the first and last controller on a network segment to add bias and prevent signal distortions due to echoing.

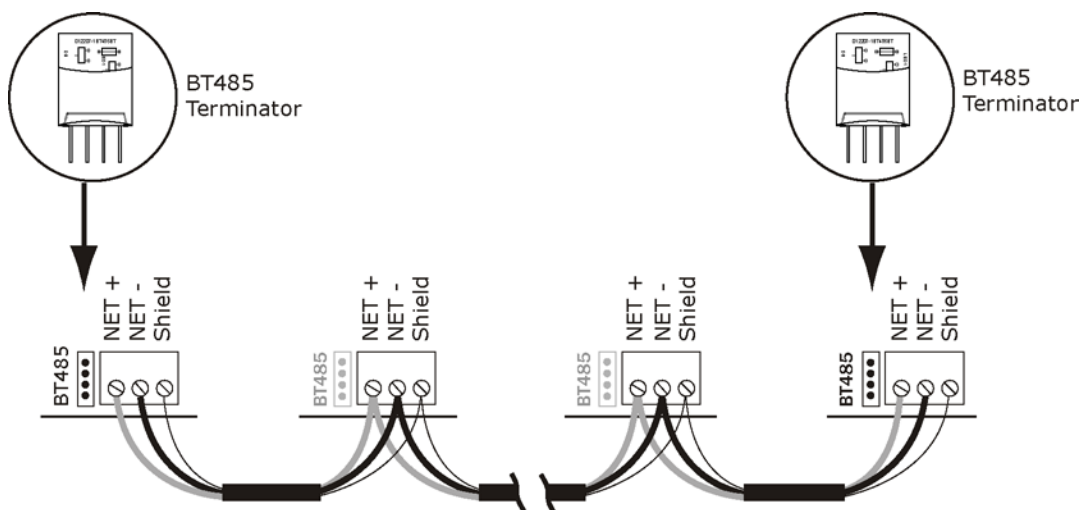

See the *MS/TP Networking and Wiring Installation Guide* for more details.

Wiring specifications

Cable:	22 AWG or 24 AWG, low-capacitance, twisted, stranded, shielded copper wire
Maximum length:	2000 feet (610 meters)

To wire the controller to the network

- 1 Pull the screw terminal connector from the controller's power terminals labeled **Gnd** and **24 Vac** or **Hot**.
- 2 Check the communications wiring for shorts and grounds.
- 3 Connect the communications wiring to the BACnet port's screw terminals labeled **Net +**, **Net -**, and **Shield**.
NOTE Use the same polarity throughout the network segment.
- 4 Verify that the **MSTP** jumper is set to **MSTP**.
- 5 Set DIP switches 1 and 2 to the appropriate baud rate. See the MSTP baud diagram on the RTU Open. The default baud rate is 76.8 kbps.
NOTE Use the same baud rate for all controllers on the network segment.
- 6 Insert the power screw terminal connector into the RTU Open's power terminals.
- 7 Verify communication with the network by viewing a module status report.

Wiring inputs and outputs

RTU Open Inputs and Outputs Table

Channel Number	Type	Signal	Function	Part Number	Wire/Terminal Numbers	Alternate Terminals
Input 1	AI	4-20 mA	CO2 OAQ Space Relative Humidity	33ZCT55C02 33ZCT56C02 33ZCSENC02 w/ 33ZCASPC02 33ZCSENSRH-01	J4 - 5 & 6	N/A
Input 2	AI	4-20 mA	CO2 OAQ Space Relative Humidity	33ZCT55C02 33ZCT56C02 33ZCSENC02 w/ 33ZCASPC02 33ZCSENSRH-01	J4 - 2 & 3	N/A
Input 3	BI	24 Vac	Compressor Safety ** Fan Status Filter Status Remote Occupancy Door Contact	N/A 33CSAS-01 33CSFS=01 Field-supplied Field-supplied	J1 - 2	J5 - 5 & 6 ***
Input 4	BI	24 Vac	Safety Chain *	N/A	J1 - 9	N/A
Input 5	BI	24 Vac	Fire Shutdown ** Fan Status Filter Status Remote Occupancy Door Contact	Field-supplied 33CSAS-01 33CSFS-01 Field-supplied Field-supplied	J1 - 10	J5 - 3 & 4 ***
Input 6	AI	10K Thermistor	Supply Air Temperature	33ZCSENSAT 33ZCSENDAT	J2 - 1 & 2	N/A
Input 7	AI	10K Thermistor	Outside Air Temperature	33ZCSENOAT	J2 - 3 & 2	N/A
Input 8	BI	24 Vac	Enthalpy ** Fan Status Filter Status Remote Occupancy Door Contact	33SENTHSW 33CSAS-01 33CSFS-01 Field-supplied Field-supplied	J2 - 6 & 7	J5 - 1 & 2 ***
Input 9	BI	24 Vac	Humidistat ** Fan Status Filter Status Remote Occupancy Door Contact	TSTATCCPLH01-B 33CSAS-01 33CSFS-01 Field-supplied Field-supplied	J5 - 7 & 8	N/A
Input 10	AI	10K Thermistor	Space Temperature	33ZCT55SPT 33ZCT56SPT 33ZCT59SPT	J20 - 1 & 2	N/A
Input 11	AI	100K Thermistor	Space Temperature Setpoint Adjust	33ZCT56SPT 33ZCT59SPT	J20 - 3 & 4	N/A
Rnet	AI		Zone Temperature	SPS / SPPL / SPP	J13 - 1, 2, 3, 4	N/A
AO - 1	AO	Economizer	Economizer	Actuator-Field-supplied	J2 - 5 & 4	N/A
AO - 2	AO	N/A	Not used	N/A	J22 - 1 & 2	N/A
BO - 1	BO	N/A - Relay	Fan (G)	N/A	J1 - 4	N/A
BO - 2	BO	N/A - Relay	Heat 2 (W2) Output	N/A	J1 - 5	N/A
BO - 3	BO	N/A - Relay	Heat 1 (W1) Output	N/A	J1 - 6	N/A
BO - 4	BO	N/A - Relay	Cool 2 (Y2) Output	N/A	J1 - 7	N/A
BO - 5	BO	N/A - Relay	Cool 1 (Y1) Output	N/A	J1 - 8	N/A
BO - 6	BO	N/A - Relay	Humidi-MiZer™	N/A	J11 - 7 & 8	N/A
BO - 7	BO	N/A - Relay	Reversing Valve	N/A	J11 - 4 & 6	N/A

Channel Number	Type	Signal	Function	Part Number	Wire/Terminal Numbers	Alternate Terminals
BO - 8	BO	N/A - Relay	Power Exhaust	N/A	J11 - 1 & 3	N/A
<p>Legend</p> <p>AI - Analog Input AO - Analog Output BI - Digital Input BO - Digital Output</p> <p>* Safety Chain Feedback - 24 Vac required at this wire to provide Run Enabled status. Provide a jumper from J1 - 1 to J1 - 9 if no safeties are utilized. See <i>To wire inputs and outputs</i> (page 14) for additional information on the RTU Open wiring harness assembly terminations.</p> <p>** Default input function</p> <p>*** Parallel screw terminal at J5 (J5 - 1 = J2 - 6, J5 - 3 = J1 - 10, J5 - 5 = J1 - 2) may be used in place of the associated flying leads at the harness (OPN-RTUHRN). See <i>To wire inputs and outputs</i> (page 14) for additional information.</p>						

Input wiring specifications

Input	Maximum length	Minimum gauge	Shielding
Thermistor	1000 feet (305 meters)	22 AWG	Unshielded
4-20 mA	3000 feet (914 meters)	22 AWG	Unshielded
Binary input	1000 feet (305 meters)	22 AWG	Unshielded
SPT (RNET)	500 feet (152 meters)	22 AWG 4 conductor	Unshielded

Inputs

These RTU Open inputs accept the following signal types:

These Inputs...	Support this signal type...	Description
1, 2	4-20 mA	The input resistance on the positive (+) terminal is 250 Ohms. The Aux Power Out terminal is capable of supplying 24 Vdc to a 4-20 mA transducer, but the total current demanded must not exceed 40 mA. If the voltage measured from the Aux Power Out terminal to Gnd is less than 18 Vdc, you need to use an external power supply.
3, 5, 8, 9	Binary (24 Vac)	24 Vac voltage, resulting in a 25 mA maximum sense current when the contacts are closed
6, 7, 10	Thermistor	10 kOhm at 77 ° F
11	100k Potentiometer	Typically used for 33CZT56SPT Setpoint Offset Potentiometer

Binary outputs

The RTU Open has 8 binary outputs. You can connect each output to a maximum of 24 Vac/Vdc. Each output is a dry contact rated at 3 A, 24 V maximum, and is normally open.

To size output wiring, consider the following:

- Total loop distance from the power supply to the controller, and then to the controlled device
NOTE Include the total distance of actual wire. For 2-conductor wires, this is twice the cable length.
- Acceptable voltage drop in the wire from the controller to the controlled device
- Resistance (Ohms) of the chosen wire gauge
- Maximum current (Amps) the controlled device requires to operate

Analog output

The RTU Open has 1 analog output that supports voltage or current devices. The controlled device must share the same ground as the controller and have input impedance of 500 Ohms maximum for the 4-20 mA mode on AO - 1.

To wire inputs and outputs

- 1 Turn **off** the RTU Open's power.
- 2 Connect the input wiring to the screw terminals on the RTU Open.
- 3 Turn **on** the RTU Open's power.
- 4 Set the appropriate jumpers on the RTU Open.

J3	AO - 1	0 - 10 Vdc/4-20 mA
W1	Battery Jumper	In (Do not remove)
W2	Format Jumper*	Out
W3	Input 11 mA Jumper	Out (mA not utilized on this channel)
W4	Input 11 Thermistor	In (default position)
W5	Input 10 mA Jumper	Out (mA not utilized on this channel)
W6	Input 10 Thermistor Jumper	In (default position)

*Formatting the controller may result in lost information and should only be done under the guidance of Carrier Control Systems Support.

RTU Open Wiring Harness Assembly Terminations

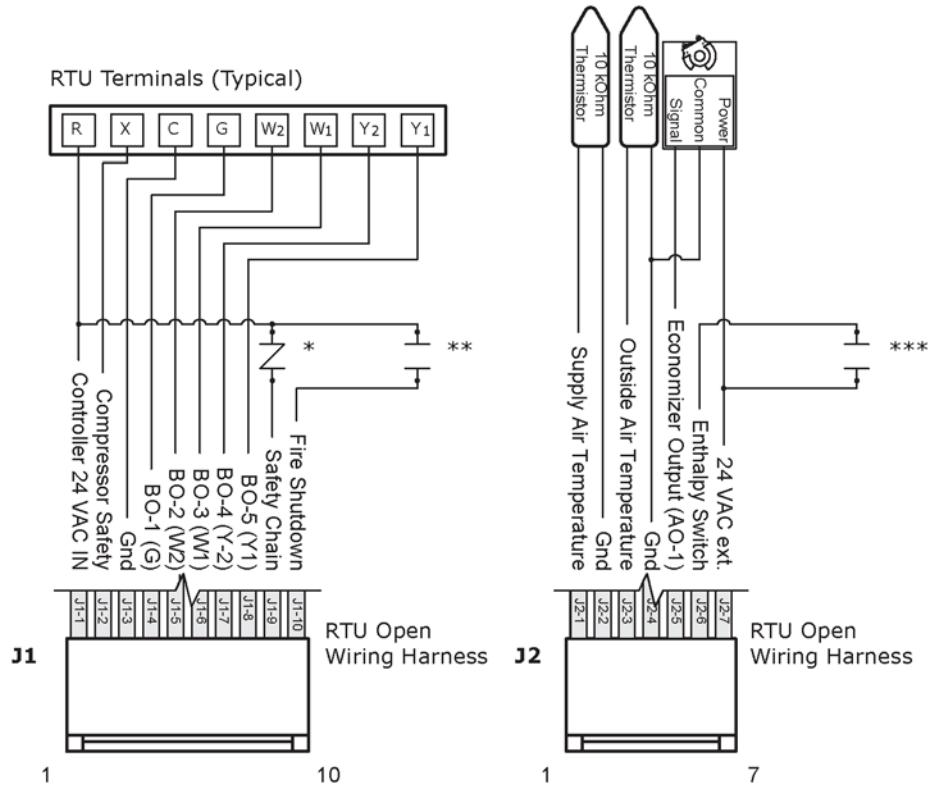

Optional

- * Safety chain devices, field-installed - normally closed. Apply 24 Vac to this terminal (jumper from J1 - 1 to J1 - 9) where no safety devices are installed.
- ** Fire shutdown device, field-installed, configurable as normally open or closed
- *** Enthalpy switch, field-installed - configurable as normally open or closed

J4 Inputs

- 1 Turn **off** the RTU Open's power.
- 2 Connect the input and output wiring to the screw terminals on the RTU Open.

NOTE When utilizing the controller's 24 Vdc auxiliary power out, the total current demand for these two input channels must not exceed 40 mA (100mA per channel).

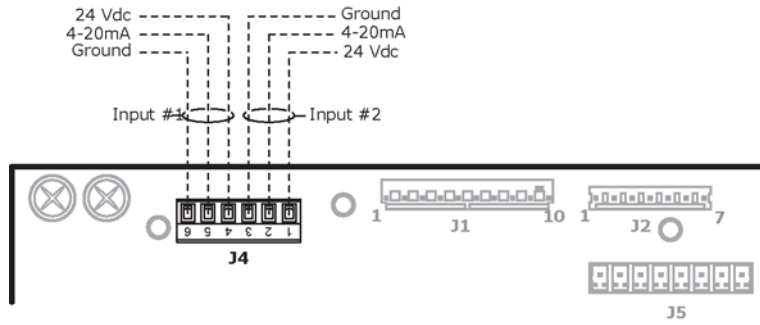

NOTE J4 Analog Inputs 1 and 2 may be set for the following device types:

- IAQ Sensor
- OAQ Sensor
- Space RH Sensor

J5 Inputs

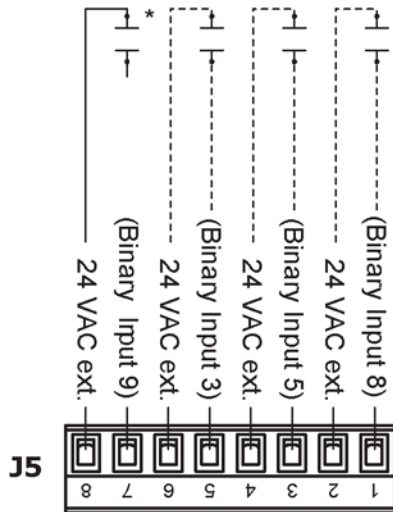

The terminals for Inputs 3, 5, and 8 are available for use in place of the flying wire leads at Molex connectors **J1** and **J2** identified below:

NOTE J5 binary inputs 3, 5, and 8 are the same input channels as:

- **J1** wire 2, **J5** - Input - 3 (**Compressor Safety**)
- **J1** wire 10, **J5** - Input - 5 (**Fire Shutdown**)
- **J2** wire 6, **J5** - Input - 8 (**Enthalpy Switch**).

These terminals are available for use in place of the flying wire leads at Molex connectors **J1** and **J2**.

Binary inputs are configurable and may be used for the following functions:

Input	Default input function	Additional functions
3	Compressor Safety	Fan Status Filter Status Remote Occupancy Door Contact
5	Fire Shutdown	Fan Status Filter Status Remote Occupancy Door Contact
8	Enthalpy Switch	Fan Status Filter Status Remote Occupancy Door Contact
9	HumidiStat	Fan Status Filter Status Remote Occupancy Door Contact

J11 Outputs

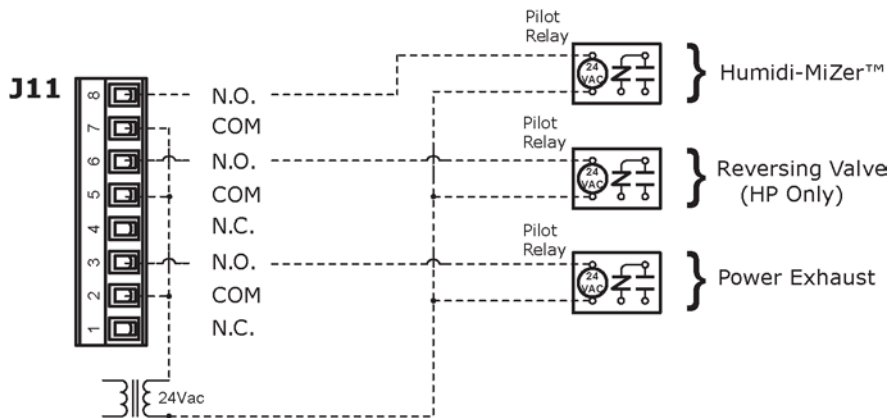

NOTE Output relay contacts rated at 3A, 24V maximum. Install pilot relays required by application.

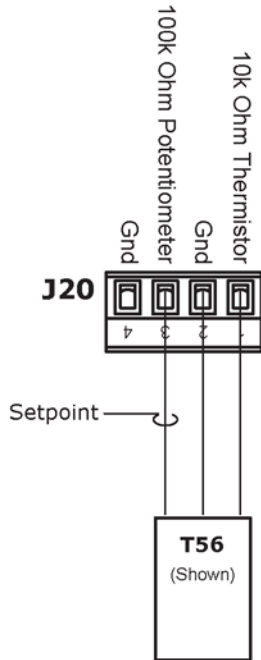

NOTE J20 Analog Inputs 10 and 11 are reserved for a 10k Ohm space temperature sensor with an optional 100k Ohm offset potentiometer used for setpoint adjustment.

Wiring sensors to inputs

You may wire various sensors to the RTU Open's inputs. See the table below for details.

NOTE This document gives instructions for wiring the sensors to the RTU Open. For specific mounting and wiring instructions, see the *Carrier Sensors Installation Guide*.

All field control wiring that connects to the RTU Open must be routed through the raceway built into the corner post. The raceway provides the UL-required clearance between high-and low-voltage wiring.

- 1 Pass the control wires through the hole provided in the corner post.
- 2 Feed the wires through the raceway to the RTU Open.
- 3 Connect the wires to the removable Phoenix connectors.
- 4 Reconnect the connectors to the board (where removed).

NOTE For rooftop unit installation, see the base unit installation instructions.

 **Warning!**

ELECTRICAL SHOCK HAZARD

Failure to follow this warning could cause personal injury, death, and/or equipment damage.

Disconnect all power to the unit before performing maintenance or service. Unit may automatically start if power is not disconnected.

Field-supplied sensor hardware

The RTU Open controller is configurable with the following field-supplied sensors:

Sensor	Part numbers	Notes
Space temperature sensor (page 20)	SPS, SPPL, SPP, 33ZCT55SPT, 33ZCT56SPT, 33ZCT59SPT	
Supply air temperature sensor (page 21)	33ZCSENSAT	Factory-installed
Duct air temperature sensor (page 22)	33ZCSENDAT	
Outdoor air temperature sensor (page 23)	33ZCSENOAT	Factory-supplied with Economizer
CO2 sensor (page 24)	33ZCSENC02, 33ZCT55C02, 33ZCT56C02	Required only for demand control ventilation - a dedicated 24-vac transformer is required
Outdoor air quality sensor (page 25)	33ZCTSENC02	Optional with demand control ventilation
Duct relative humidity sensor (page 26)	33ZCSENDRH-01	
Space relative humidity sensor (page 26)	33ZCSENSRH-01	
Humidistat (page 27)	TSTATCCPLH01-B	
CO2 aspirator box (page 24)	C33ZCCASPC02	Required for CO2 return duct/outside air applications
Outdoor air enthalpy switch (page 28)	33CSENTHSW	
Return air enthalpy sensor (page 28)	33CSENSEN	Optional with 33CSENTHSW
Filter status switch (page 31)	33CSFS-01	
Fan status switch (page 31)	33CSAS-01 or field-supplied	

For specific details about sensors, see the *Carrier Sensors Installation Guide*.

Wiring an SPT sensor

The RTU Open is connected to a wall-mounted space temperature sensor to monitor room temperature.

An i-Vu Open Control System offers the following SPT sensors:

Sensor	Part #	Features
SPT Standard	SPS	<ul style="list-style-type: none"> Local access port No operator control
SPT Plus	SPPL	<ul style="list-style-type: none"> Slide potentiometer to adjust setpoint MANUAL ON button to override schedule LED to show occupied status Local access port
SPT Pro	SPP	<ul style="list-style-type: none"> LCD display MANUAL ON button to override schedule WARMER and COOLER buttons to adjust setpoint INFO button to cycle through zone and outside air temperatures, setpoints, and local override time Local access port

You wire SPT sensors to the RTU Open's **Rnet** port. An Rnet can consist of any of the following combinations of devices wired in a daisy-chain configuration:

- 1 SPT Plus or SPT Pro
- 1-4 SPT Standards
- 1-4 SPT Standards, and 1 SPT Plus or SPT Pro
- Any of the above combinations, plus up to 2 BACview⁶s but no more than 6 devices total

NOTES

- If you have 2 BACview⁶s, the second BACview⁶ must have a separate power supply with the same ground as the controller.
- If the Rnet has multiple SPT Standard sensors, you must give each a unique address on the Rnet. See the *Carrier Sensors Installation Guide*.
- If the Rnet has multiple BACviews, you must give each a unique address on the Rnet. See the *BACview Installation and User Guide*.

Rnet wiring specifications

NOTE Use the specified type of wire and cable for maximum signal integrity.

Description	4 conductor, unshielded, CMP, plenum rated cable
Conductor	18 AWG
Maximum length	500 feet (152 meters)
Recommended coloring	Jacket: White Wiring: Black, white, green, red
UL temperature rating	32-167 °F (0-75 °C)

Voltage	300 Vac, power limited
Listing	UL: NEC CL2P, or better

To wire the SPT sensor to the controller

- Partially cut, then bend and pull off the outer jacket of the Rnet cable(s). Do not nick the inner insulation. Strip about .25 inch (.6 cm) of the inner insulation from each wire.

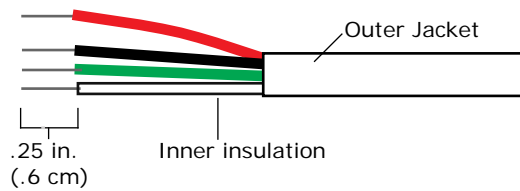

- Wire each terminal on the sensor to the same terminal on the controller. See diagram below.

NOTE Carrier recommends that you use the following Rnet wiring scheme:

Connect this wire...	To this terminal...
Red	+12V
Black	Rnet-
White	Rnet+
Green	Gnd

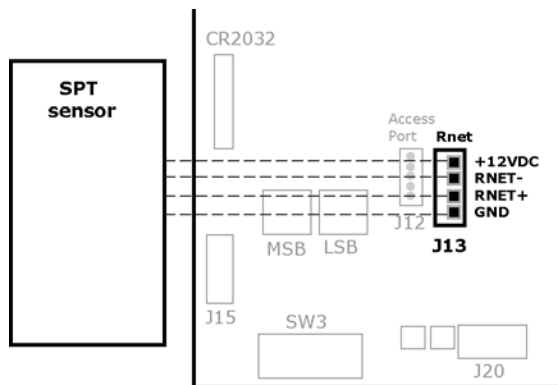

Wiring a Supply Air Temperature sensor

Part #33ZCSENSAT

The RTU Open requires a temperature sensor installed in the supply air stream. The Supply Air Temperature (SAT) sensor is used when the rooftop unit is equipped with electric heating.

Wiring specifications

Cable from sensor to controller:	If <100 ft (30.5 meters) If >100 ft (30.5 meters)	22 AWG, unshielded 22 AWG, shielded
Maximum length:	500 feet (152 meters)	

To wire the SAT sensor to the controller

- 1 Connect the wiring harness (OPN-RTUHRN). For details, see *To wire inputs and outputs* (page 14).
- 2 Wire the sensor to the wiring harness. See diagram below.
- 3 Connect to **J2** wires 1 and 2.
- 4 Verify your sensor readings.

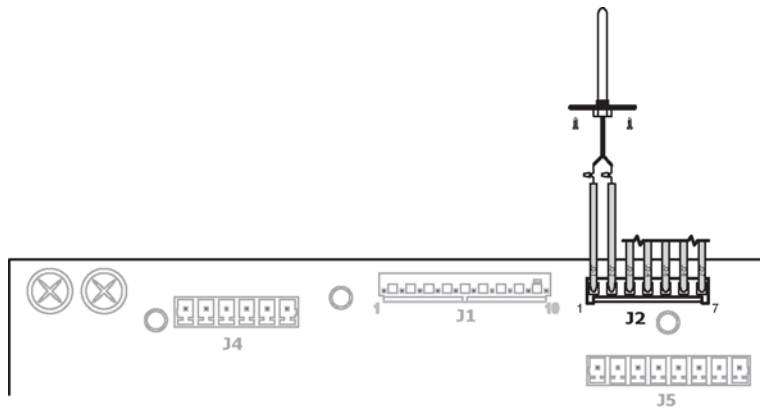

Wiring a Duct Air Temperature sensor

Part #33ZCSENDAT

The RTU Open requires a temperature sensor installed in the supply air stream. The Duct Temperature (DAT) sensor is generally used when the rooftop unit is NOT equipped with electric heating.

Wiring specifications

Cable from sensor to controller:	If <100 ft (30.5 meters) If >100 ft (30.5 meters)	22 AWG, unshielded 22 AWG, shielded
Maximum length:	500 feet (152 meters)	

To wire a duct sensor to the controller

- 1 Connect the wiring harness (Part#OPN-RTUHRN). For details, see *To wire inputs and outputs* (page 14).
- 2 Wire the sensor to the wiring harness. See diagram below.
- 3 Connect to **J2** wires 1 and 2.
- 4 Verify your sensor readings.
- 5 Drill .25" diameter hole. Pass sensor leads through bushing and insert assembly into hole. Secure leads to ductwork with aluminum tape.

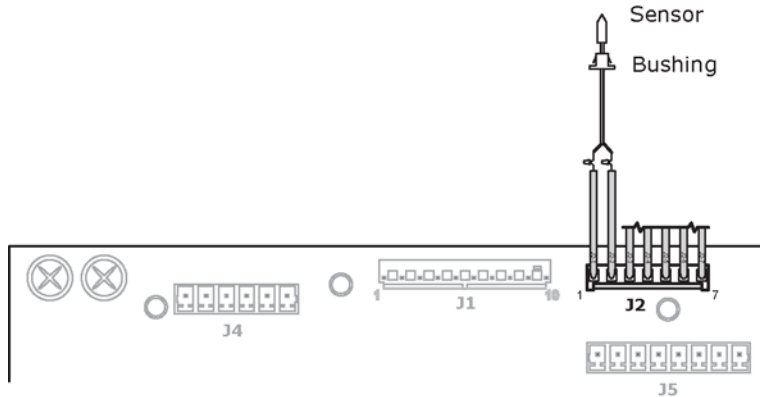

NOTE Sensor termination requires installation of RTU Open wiring harness assembly (Part #OPN-RTUHRN).

Wiring an Outdoor Air Temperature sensor

Part #33ZCSENOAT

Outdoor Air Temperature (OAT) is required to utilize all of the RTU Open's features. OAT may be provided by a local sensor (shown below) or a linked sensor in another controller. See *Single Point Linkage* (page 73).

Wiring specifications

Cable from sensor to controller:	If <100 ft (30.5 meters)	22 AWG, unshielded
	If >100 ft (30.5 meters)	22 AWG, shielded
Maximum length:	500 feet (152 meters)	

To wire an OAT sensor to the controller

- 1 Connect the wiring harness (Part#OPN-RTUHRN). For details, see *To wire inputs and outputs* (page 14).
- 2 Wire the sensor to the wiring harness. See diagram below.

- 3 Connect to **J2** wires 3 and 4.
- 4 Verify your sensor readings.

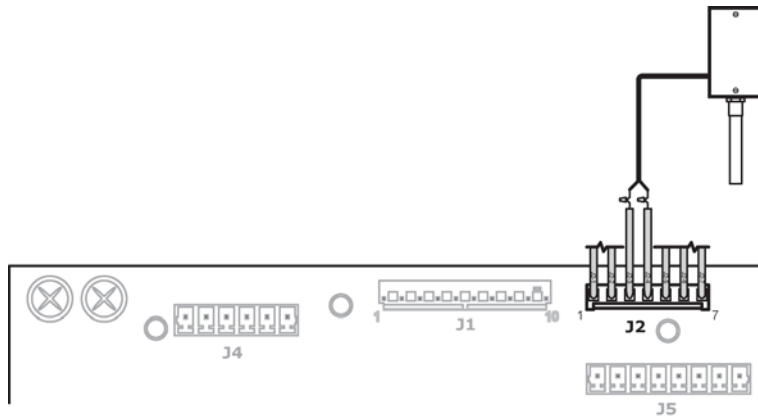

Wiring a CO2 sensor

- Part #33ZCSENC02 (Display model)
- Part #33ZCT55C02 (No display)
- Part #33ZCT56C02 (No display)

A CO₂ sensor monitors carbon dioxide levels. As CO₂ levels increase, the RTU Open adjusts the outside air dampers to increase ventilation and improve indoor air quality. A CO₂ sensor can be wall-mounted or mounted in a return air duct. Duct installation requires an Aspirator Box Accessory (Part #33ZCASPC02).

The sensor has a range of 0–2000 ppm and a linear 4-20 mA output. The CO₂ sensor’s power requirements exceed what is available at **J4** - 1 and 4. Provide a dedicated 24Vac transformer or DC power supply

Wiring specifications

Cable from sensor to controller:	If <100 ft (30.5 meters)	22 AWG, unshielded
	If >100 ft (30.5 meters)	22 AWG, shielded
Maximum length:	500 feet (152 meters)	

To wire the CO2 sensor to the controller

- 1 Wire the sensor to the controller. See appropriate diagram below.
- 2 Install a field-supplied dedicated 24 Vac transformer or DC power supply.
- 3 Wire the sensor to the controller.

Wiring diagram for #33ZCSENC02:

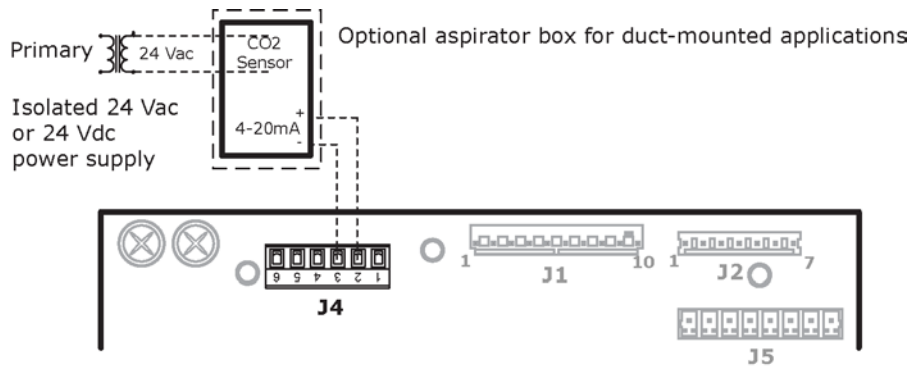

Wiring diagram for #33ZCT55/56CO2:

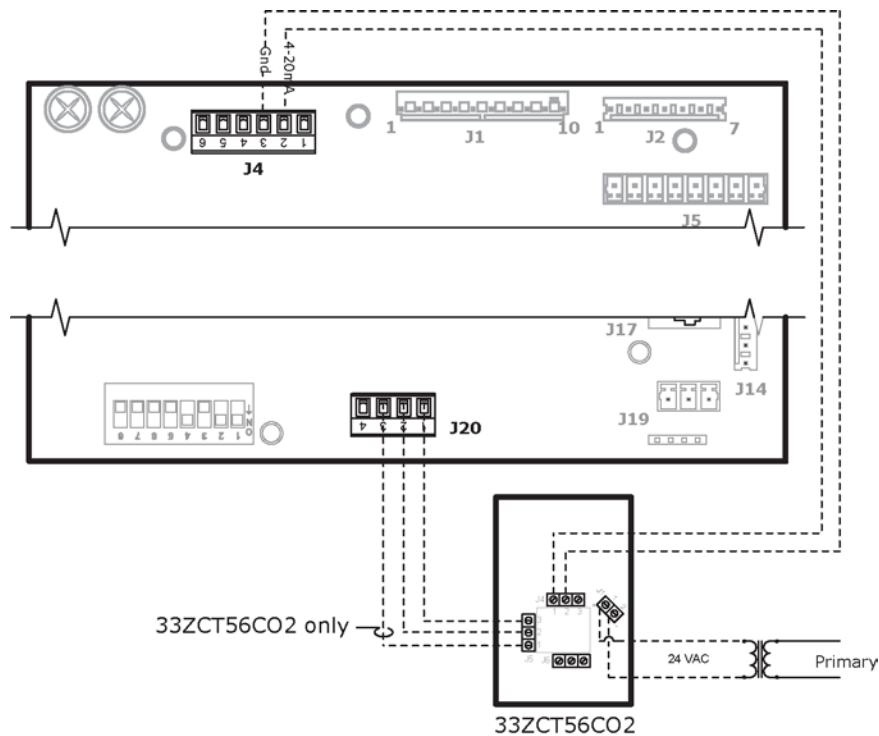

Wiring an Outdoor Air Quality sensor

Part #33ZCSENC02 (Display model)

An outdoor air quality (OAQ) sensor monitors outside air carbon dioxide levels. The RTU Open uses this information, in conjunction with a CO2 sensor, to adjust the outside air dampers to provide proper ventilation. An OAQ sensor is typically duct-mounted in the outside air stream. Duct installation requires an Aspirator Box Accessory (Part #33ZCASPC02).

The sensor has a range of 0–2000 ppm and a linear 4-20 mA output. The CO2 sensor’s power requirements exceed what is available at **J4** - 1 and 4. Provide a dedicated 24 Vac transformer or DC power supply.

Wiring specifications

Cable from sensor to controller:	If <100 ft (30.5 meters)	22 AWG, unshielded
	If >100 ft (30.5 meters)	22 AWG, shielded
Maximum length:	500 feet (152 meters)	

To wire the OAQ sensor to the controller

- 1 Wire the sensor to the controller. See appropriate diagram below.
- 2 Install a field-supplied dedicated 24 Vac transformer or DC power supply.
- 3 Apply power and verify sensor readings.

Wiring diagram for #33ZCSENC02:

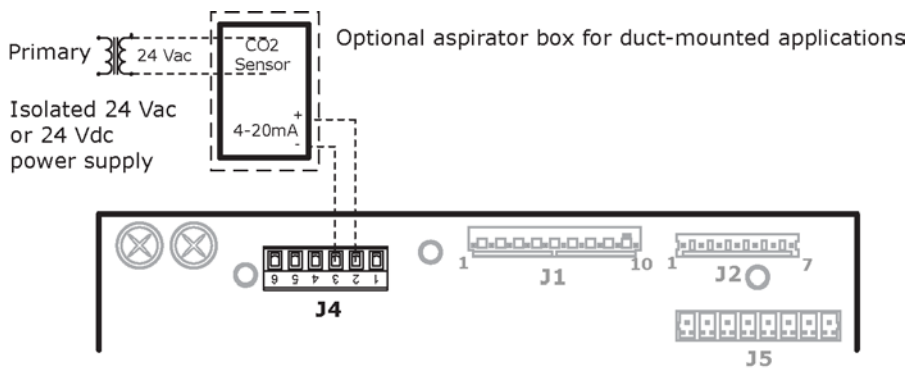

NOTE Sensor may be terminated at Input 1 or 2.

Wiring a Relative Humidity sensor

Wall sensor - Part #33ZCSENSRH-01
 Duct sensor - Part #OPNSENSRH-01

The Relative Humidity (RH) sensor may be used for zone humidity control (dehumidification) when applied to a Carrier rooftop unit equipped with the Humidi-MiZer™ option. On units not equipped for dehumidification, the sensor monitors humidity, but provides no control.

NOTE You cannot use a relative humidity sensor when using both a CO2 and OAQ sensor on the controller.

Wiring specifications

Cable from sensor to controller:	If <100 ft (30.5 meters) If >100 ft (30.5 meters)	22 AWG, unshielded 22 AWG, shielded
Maximum length:	500 feet (152 meters)	

To wire the RH sensor to the controller

- 1 Strip the outer jacket from the cable for at least 4 inches (10.2 cm). Strip .25 inch (.6 cm) of insulation from each wire.
- 2 Wire the sensor to the controller. See diagram below.
- 3 Apply power and verify sensor readings.

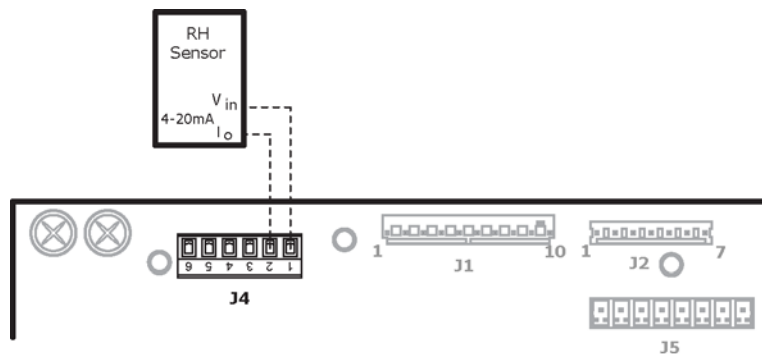

NOTE Sensor may be terminated at Input 1 or 2.

Wiring a Humidistat

Locally Purchased

A humidistat may be used for zone humidity control (dehumidification) when applied to a Carrier rooftop unit equipped with the Humidi-MiZer™ option. On units not equipped for dehumidification, the humidistat will indicate a high humidity condition only.

Wiring specifications

Cable from sensor to controller:	If <100 ft (30.5 meters) If >100 ft (30.5 meters)	22 AWG, unshielded 22 AWG, shielded
Maximum length:	500 feet (152 meters)	

To wire a humidistat to the controller

- 1 Strip the outer jacket from the cable for at least 4 inches (10.2 cm). Strip .25 inch (.6 cm) of insulation from each wire
- 2 Wire the humidistat to the controller. See diagram below.
- 3 Apply power and verify sensor readings.

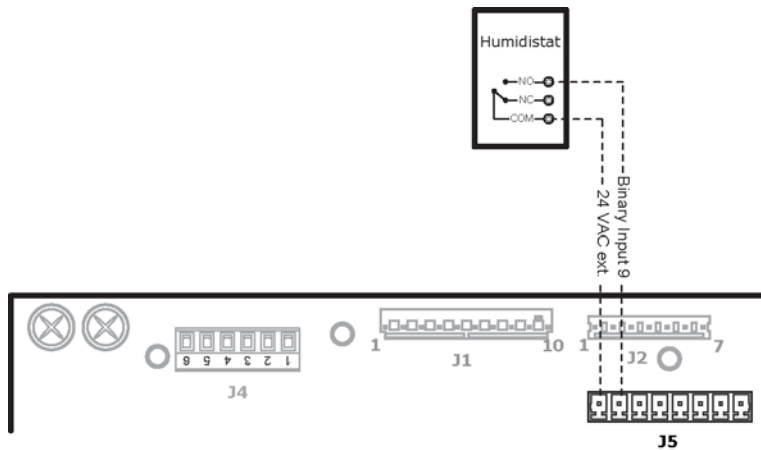

NOTE Humidistat may be return duct or space mounted.

Wiring an enthalpy switch

Outdoor Air - Part #33CSENTHSW

Return air - Part #33CSENSEN

The 33CSENTHSW is an outdoor air enthalpy switch/receiver. This control determines the suitability of the outdoor air as a cooling source, based on the heat content of the air. Differential enthalpy control requires installing a 33CSENSEN enthalpy sensor in the rooftop unit's return air duct.

Wiring specifications

Cable from sensor to controller:	If <100 ft (30.5 meters)	22 AWG, unshielded
	If >100 ft (30.5 meters)	22 AWG, shielded
Maximum length:	500 feet (152 meters)	

Wiring diagram for factory-installed enthalpy switch:

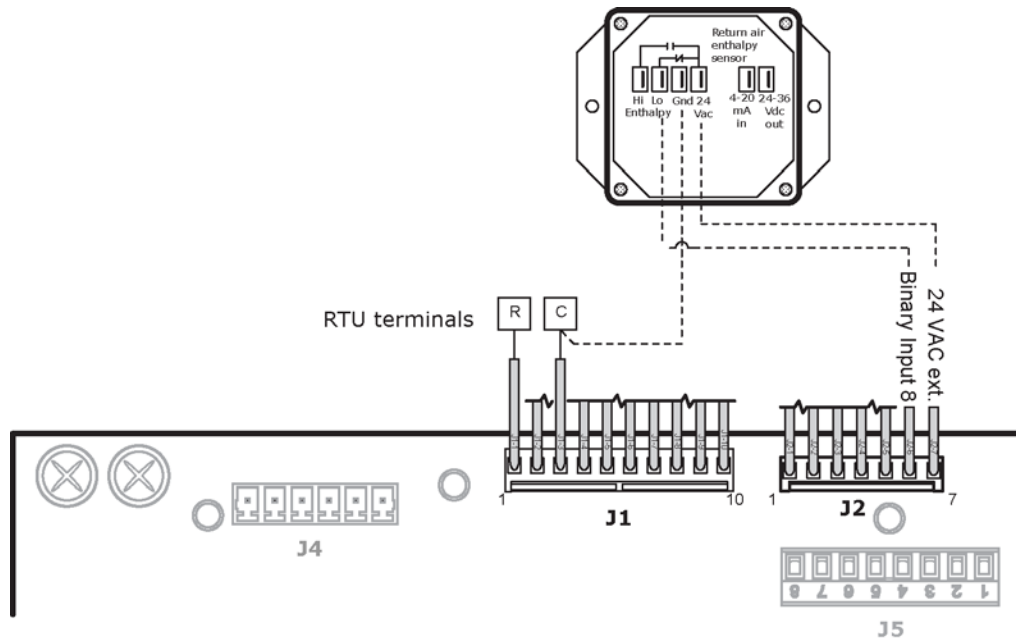

NOTE Factory-installed enthalpy switches terminate at **J2** wires 6 (switch input) and 7 (24 Vac).

To wire an enthalpy switch (differential) to the controller

Wiring diagram for optional enthalpy sensor mounted in the return air for differential enthalpy:

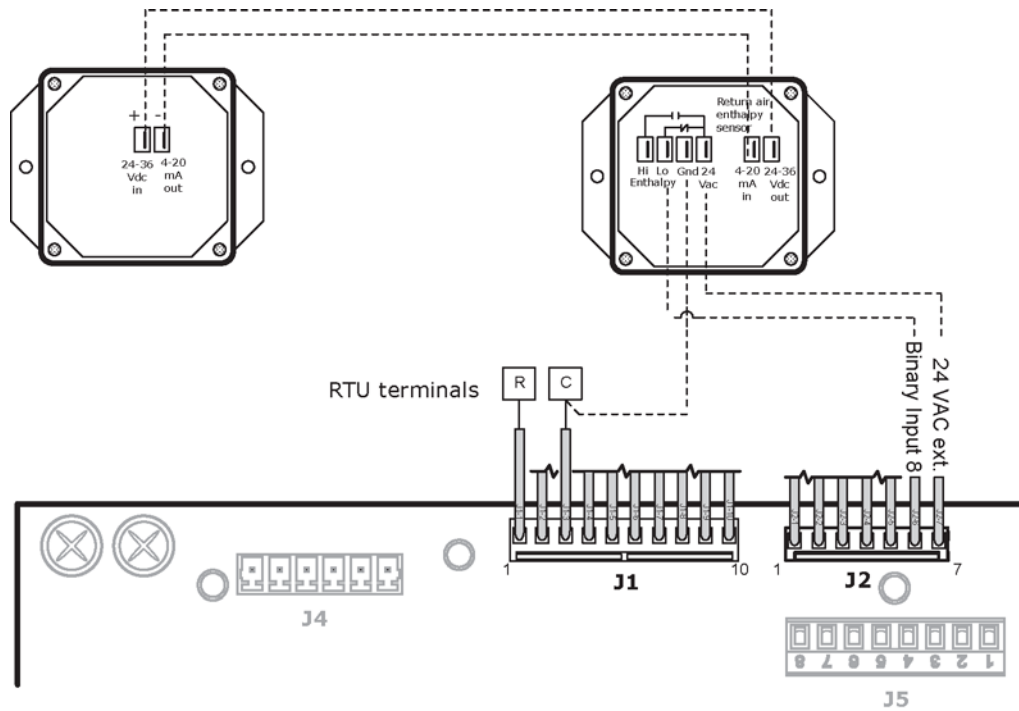

Wiring a status switch

- Filter - Part #33CSFS-01 or field-supplied
- Fan status - Part #33CSAS-01 or field-supplied

Filter and/or fan status switches may be installed to provide a **Dirty Filter** indication or **Fan Running** status.

Wiring specifications

Cable from sensor to controller:	If <100 ft (30.5 meters)	22 AWG, unshielded
	If >100 ft (30.5 meters)	22 AWG, shielded
Maximum length:	500 feet (152 meters)	

To wire a status switch to the controller

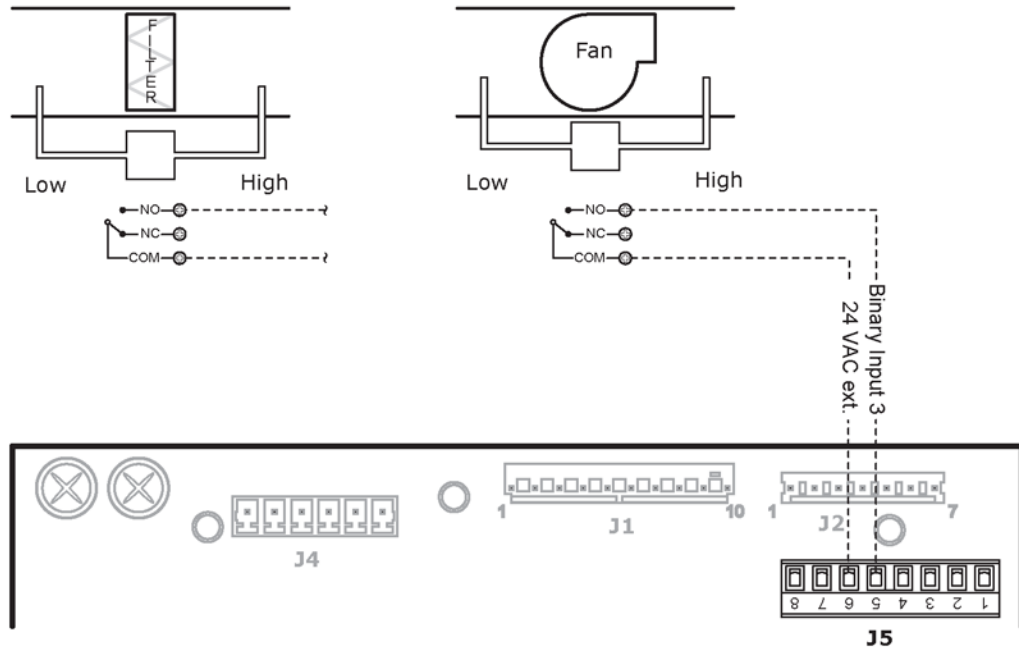

NOTES

- Binary inputs 3, 5, 8, and 9 are configurable and may be used for **Fan Status, Filter Status, Remote Occupancy, or Door Contacts**, if they have not already been used for their default functions.
- Follow device manufacturer's installation and operating instructions.

Wiring a compressor safety

This is typically provided by the manufacturer with the rooftop equipment. A compressor safety status may be monitored if available.

Wiring specifications

Cable from sensor to controller:	If <100 ft (30.5 meters) If >100 ft (30.5 meters)	22 AWG, unshielded 22 AWG, shielded
Maximum length:	500 feet (152 meters)	

To wire a compressor safety input to the controller

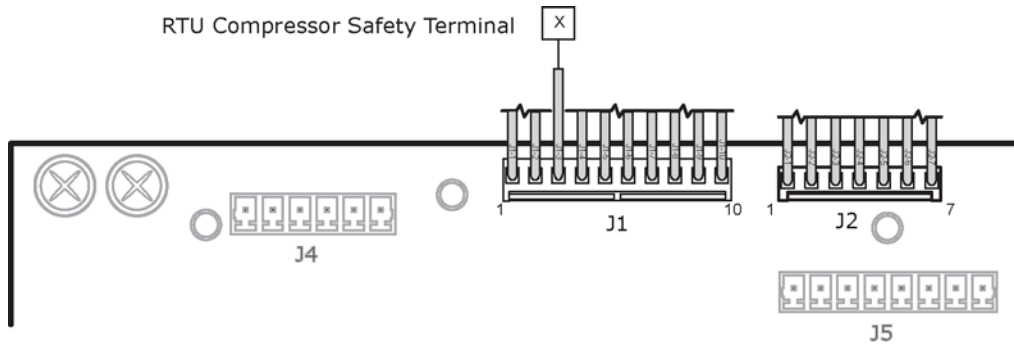

NOTES

- An isolation relay may be required if the RTU Open is powered separately from the equipment's control power circuit.
- Follow device manufacturer's installation and operating instructions.

Wiring an occupancy switch or door contact

Occupancy switch - field-supplied

Door contact - field-supplied

Occupancy or door contact switches may be installed to provide an alternate means of occupancy determination or heating and cooling lockout. See *Sequence of Operation* (page 42) for additional details.

Wiring specifications

Cable from sensor to controller:	If <100 ft (30.5 meters)	22 AWG, unshielded
	If >100 ft (30.5 meters)	22 AWG, shielded
Maximum length:	500 feet (152 meters)	

To wire an occupancy switch or door contact

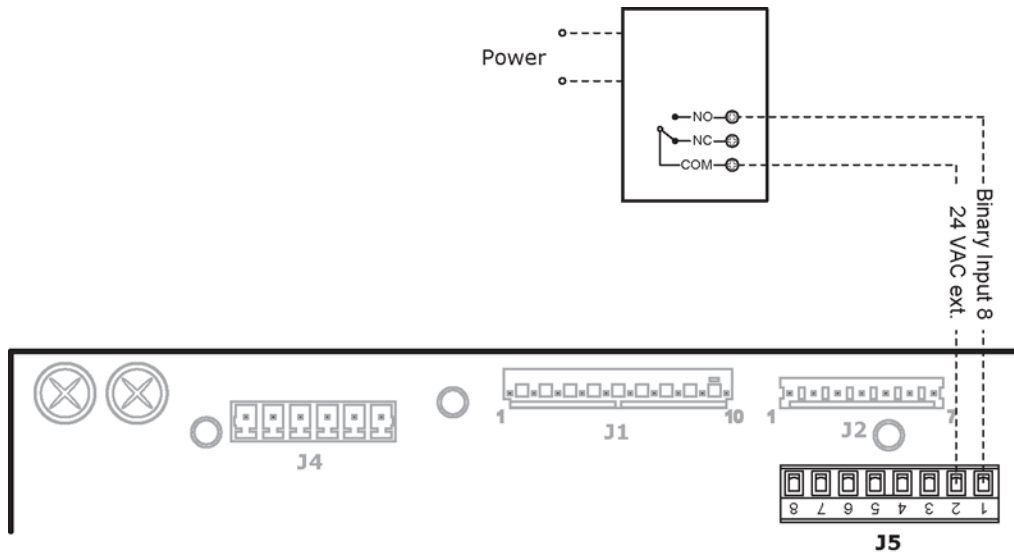

NOTES

- Binary Inputs 3, 5, 8, and 9 are configurable and may be used for **Fan Status, Filter Status, Remote Occupancy, or Door Contacts** - provided they have not been utilized for their default functions.
- Follow device manufacturer's installation and operating instructions.

Start-up

To start up the RTU Open, you need one of the following user interfaces to the controller. These items let you access the controller information, read sensor values, and test the controller.

This Interface...	Provides a...
I-Vu Open software	Permanent interface
Field Assistant software - runs on a laptop connected to controller's Local Access port ¹	Temporary interface
Virtual BACview software - runs on a laptop connected to controller's Local Access port ^{1, 2}	Temporary interface
BACview6 Handheld keypad/display unit - connects to controller's Local Access port ^{1, 2}	Temporary interface
BACview6 keypad/display unit connected to controller's Rnet port ²	Permanent interface

¹ Requires a USB Link (USB-L).

² See the *BACview Installation and User Guide* for instructions on connecting and using the above items.

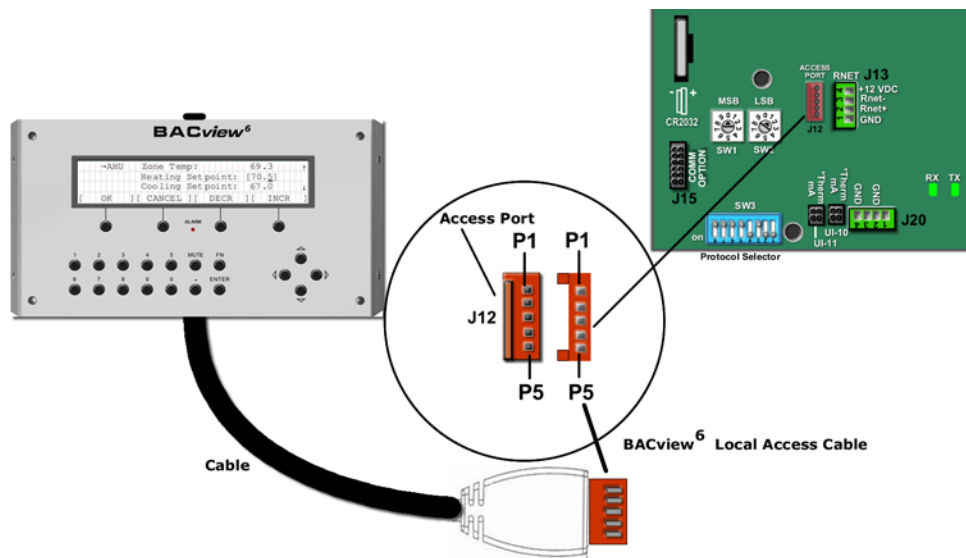

Service Test

Navigation: i-Vu / Field Assistant: **Properties > Equipment > Configuration > Service Configuration > Service Test**
 BACview: **HOME > CONFIG > SERVICE > TEST**

Service Test can be used to verify proper operation of compressors, heating stages, indoor fan, power exhaust fans, economizer, and dehumidification. It is highly recommended to use **Service Test** at initial system start-up and during troubleshooting. See *Appendix A: Points/Properties* (page 58) for more information.

Service Test differs from normal operation as follows:

- Outdoor air temperature limits for cooling circuits, economizer, and heating are ignored.
- Normal compressor time guards and other staging delays are ignored.
- Alarm statuses (except **Fire** and **Safety Chain**) are ignored, but all alarms and alerts are still broadcast on the network, if applicable.

Service Test can be turned on or off from BACview, Field Assistant, or i-Vu. Select **Default Value** of **Enable** to turn on and **Disable** to turn off.

NOTES

- **Service Test** mode is password-protected when accessed from a BACview.
- **Service Test** allows testing of each controller output.
- **Binary Service Test** functions are on when the **Default Value** is set to **Enable** and off when set to **Disable**.
- The output of the **Analog Service Test** is controlled by the percentage (0-100%) entered into the **Default Value**.
- It is recommended to return every **Service Test** variable to **Disable** or **0.00** after testing each function (unless that test variable must be active to test a subsequent function, as in **Compressor 2 Test**).
- All outputs return to normal operation when **Service Test** is set to **Disable**.

Service Test functions

- Use **Fan Test** to activate and deactivate the **Supply Fan** (BO - 1) output. Note that this output may enable simultaneously with other **Service Test** modes even with its **Default Value** set to **Disable**.
- Use **Compressor 1 Test** to activate and deactivate the Compressor 1 (BO - 5) output. The **Supply Fan** output will be activated and deactivated in conjunction with this output. Leave **Compressor 1 Test** on **Enable** if **Compressor 2 Test** is required.
- Use **Compressor 2 Test** to activate and deactivate the Compressor 2 (BO - 4) output. Always test the Compressor 1 output first. **Compressor 1 Test** output must be set to **Enable** for **Compressor 2 Test** to function.
- Use the **Reversing Valve Test** to activate and deactivate the reversing valve (BO - 7) output.
- Use the **Dehumidification Test** to activate and deactivate the Humidi-MiZer™ (BO - 6) output. The Supply Fan output will be activated and deactivated in conjunction with the Dehumidification Test output.
- Use **Heat 1Test** to activate and deactivate the Heat 1 (BO - 3) output. The Supply Fan output is activated and deactivated in conjunction with the **Heat 1Test** output.
- Use **Heat 2Test** to activate and deactivate the Heat 2 (BO - 2) output. The Supply Fan output is activated and deactivated in conjunction with the **Heat 2Test** output.

- Use **Power Exhaust Test** to activate and deactivate the power exhaust (BO - 8) output.
- Use **Economizer Test** to set the (AO - 1) economizer output to any value from 0 to 100% of configured output (2-10 Vdc or 4-20 mA).
- **Analog Output 2 Test** (AO - 2) is currently unused and does not require testing.
- Service Test mode does not timeout. Return all test variables to **Disable** or **0.00**. Set **Service Test** to **Disable** or cycle power to the RTU Open to return to normal operation.

Configuring the RTU Open's properties

To start up the RTU Open, you need to configure the properties described in the following sections. These properties affect the unit operation and/or control. Review and understand the meaning and purpose of each property before changing it.

- *Unit Configuration properties* (page 37)
- *Setpoint Configuration properties* (page 39)
- *Service Configuration properties* (page 40)

See *Appendix A* (page 58) for a complete list of the controller's points/properties.

Unit Configuration properties

Navigation: i-Vu / Field Assistant: **Properties > Equipment > Configuration > Unit Configuration**
 BACview: **HOME > CONFIG > UNIT**

Point Name/Description	Default/Range
<p>Fan Mode – The supply fan's operating mode.</p> <p>Options: Auto - The fan cycles on/off in conjunction with heating or cooling. Continuous - The fan runs continuously during occupancy & intermittently during unoccupied periods with heating or cooling. Always On - The fan runs continuously regardless of occupancy or calls for heating and cooling.</p>	<p>D: Continuous</p> <p>R: Auto Continuous Always On</p>
<p>Occupancy Source - The method that the controller uses to determine occupancy.</p> <p>Options: Always Occupied = Controller operates continuously as occupied. BACnet Schedule = Controller follows a schedule set up in i-Vu or Field Assistant. BAS On/Off = Occupancy is set over the network by another device or a third party BAS. Remote Occ Input = Occupancy is set by a remote contact.</p>	<p>D: Always Occupied</p> <p>R: Always Occupied BACnet Schedule BAS On/Off Remote Occ Input</p>
<p>Input 1 Function – The type of sensor (4-20 mA) connected to terminals J4 – 4, 5, & 6.</p>	<p>D: No Sensor</p> <p>R: No Sensor IAQ Sensor OAQ Sensor Space RH Sensor</p>

Point Name/Description	Default/Range
Input 2 Function – The type of sensor (4-20 mA) connected to terminals J4 – 1, 2, & 3.	D: No Sensor R: No Sensor IAQ Sensor OAQ Sensor Space RH Sensor
Input 3 Function – The usage of Input 3. You must also set Input 3 Switch Configuration . Options: No Function – The input is not used. Compressor Safety – Safety device status. Fan Status – Proves supply fan operation. Filter Status – Indicates a dirty filter. Remote Occupancy – Sets occupancy using a hardware contact. Door Contact – Sets occupancy using a hardware contact.	D: Compressor Safety R: No Function Compressor Safety Fan Status Filter Status Remote Occupancy Door Contact
Input 3 Switch Configuration – The normal (de-energized) state for the set of contacts terminated at Input	D: NO R: NO/NC (normally open/normally closed)
Input 5 Function – The usage of Input 5. You must also set Input 5 Switch Configuration . Options: No Function – The input is not used. Fire Shutdown – Fire Safety device status. Inhibits operation when tripped. Fan Status – Proves supply fan operation. Filter Status – Indicates a dirty filter. Remote Occupancy – Sets occupancy using a hardware contact. Door Contact – Sets occupancy using a hardware contact.	D: Fire Shutdown R: No Function Fire Shutdown Fan Status Filter Status Remote Occupancy Door Contact
Input 5 Switch Configuration – The normal (de-energized) state for the set of contacts terminated at Input	D: NC R: NO/NC (normally open/normally closed)
Input 8 Function – The usage of Input 8. You must also set Input 8 Switch Configuration . Options: No Function – The input is not used. Enthalpy Switch – Indicates enthalpy status (high or low). Fan Status – Proves supply fan operation. Filter Status – Indicates a dirty filter. Remote Occupancy – Sets occupancy using a hardware contact. Door Contact – Sets occupancy using a hardware contact.	D: Enthalpy Switch R: No Function Enthalpy Switch Fan Status Filter Status Remote Occupancy Door Contact
Input 8 Switch Configuration – The normal (de-energized) state for the set of contacts terminated at Input	D: NO R: NO/NC (normally open/normally closed)
Input 9 Function – The usage of Input 9. You must also set Input 9 Switch Configuration . Options: No Function – The input is not used. Humidistat – Indicates high humidity condition. Fan Status – Proves supply fan operation. Filter Status – Indicates a dirty filter. Remote Occupancy – Sets occupancy using a hardware contact. Door Contact – Sets occupancy using a hardware contact.	D: Humidistat R: No Function Humidistat Fan Status Filter Status Remote Occupancy Door Contact

Point Name/Description	Default/Range
Input 9 Switch Configuration – The normal (de-energized) state for the set of contacts terminated at Input	D: NO R: NO/NC (normally open/normally closed)
Space sensor type - The type of local space temperature sensor.	D: T55 R: T55 T56 (Use for T59) SPT Sensor None

Setpoint properties

Navigation: i-Vu / Field Assistant: **Properties > Equipment > Configuration > Setpoints**
 BACview: **HOME > CONFIG > SETPOINT**

Select a color band on the setpoint graph to see the current setpoints in the **Heating** and **Cooling** fields. See setpoint descriptions below.

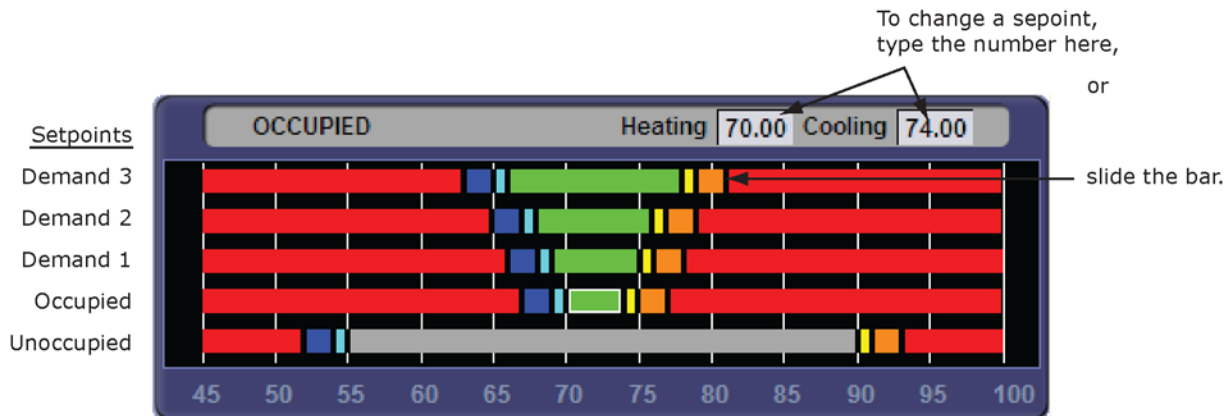

Point Name/Description	Default/Range
Occupied Heating – Green The heating setpoint the controller maintains while in occupied mode.	D: 70 °F R: -40 to 245 °F
Occupied Cooling – Green The cooling setpoint the controller maintains while in occupied mode.	D: 74 °F R: -40 to 245 °F
Unoccupied Heating – Gray The heating setpoint the controller maintains while in unoccupied mode.	D: 55 °F R: 45 to 100 °F
Unoccupied Cooling – Gray The cooling setpoint the controller maintains while in unoccupied mode.	D: 90 °F R: -40 to 245 °F

Point Name/Description	Default/Range
Optimal Start – The earliest time, prior to occupancy, at which the Optimal Start function may begin to adjust the effective setpoints to achieve the occupied setpoints by the time scheduled occupancy begins. Enter 0 to disable Optimal Start.	D: 4 hr R: 0 to 4 hr
Occ Relative Humidity Setpoint – The percentage of relative humidity in the space during occupancy that will energize BO - 6 (Humidi-MiZer™).	D: 60%rh R: 0 to Unoccupied RH Control Setpoint
Unocc Relative Humidity Setpoint – The percentage of relative humidity in the space during the unoccupied time period that starts the unit and energizes BO - 6 (Humidi-MiZer™).	D: 95% R: 30 to 100%
DCV Max Ctrl Setpoint – The design difference between indoor and outdoor CO2 levels.	D: 650ppm R: 0 to 9999 ppm
Power Exhaust Setpoint - The outside air damper position at which the controller energizes the Power Exhaust relay. Configuration >Service Configuration > Economizer Exists must be set to Yes , and Configuration >Service Configuration > Continuous Occupied Exhaust must be set to No .	D: 50% Open R: 20 to 90% Open

Service Configuration properties

Navigation: i-Vu / Field Assistant: **Properties > Equipment > Configuration > Service Configuration**
 BACview: **HOME > CONFIG > SERVICE**

Point Name/Description	Default/Range
Unit Type – The type of equipment that the RTU Open is controlling. Options: Heat/Cool – Standard rooftop air handling unit. HP O/B Ctrl – Heat Pump application, uses reversing valve output to control heating and cooling. HP Y1/W1 Ctrl – Carrier Heat Pump application only.	D: Heat/Cool R: Heat/Cool HP O/B Ctrl HP Y1/W1 Ctrl
Compressor Stages – The number of mechanical cooling stages.	D: One Stage R: One Stage Two Stages
Economizer Exists – Set to Yes to enable economizer control for units equipped with an economizer damper.	D: No R: No/Yes
Reversing Valve Output – Set to O = Reversing Valve output on with cooling. Set to B = Reversing Valve output on with heating.	D: O R: O / B
Heat Type – The type of heating that the unit has.	D: Electric R: Electric/Gas
Number Of Heat Stages – The number of heat stages.	D: 2 R: 1 / 2 / 0 (no heating)

Point Name/Description	Default/Range
Continuous Occupied Exhaust – Configures the exhaust fan control strategy (B0-8). If Yes , the power exhaust runs continuously in occupied mode and is off in unoccupied mode. If No , the power exhaust is controlled by the Power Exhaust Setpoint .	D: No R: No/Yes
Indoor CO2 Sensor Value @min (ma) – The CO2 value that corresponds to a 4mA input at the appropriate input channel.	D: 0ppm R: 0 to 9999 ppm
Indoor CO2 Sensor Value @max (ma) – The CO2 value that corresponds to a 20mA input at the appropriate input channel.	D: 2000 ppm R: 0 to 9999 ppm
Outdoor CO2 Sensor Value @min (ma) – The CO2 value that corresponds to a 4 mA input at the appropriate input channel.	D: 0ppm R: 0 to 9999 ppm
Outdoor CO2 Sensor Value @max (ma) – The CO2 value that corresponds to a 20 mA input at the appropriate input channel.	D: 2000 ppm R: 0 to 9999 ppm

Sequence of Operation

The RTU Open supports various types of constant volume air source configurations:

- Standard heat/cool unit types with up to 2-stages of mechanical cooling and gas or electric heating
- Heat pump units utilizing a reversing valve output for heating and cooling control
- Heat pump unit (Carrier) with an OEM control board
- Economizer, CO₂, Demand Limiting, and RH control strategies are available for appropriately equipped units

The RTU Open may operate as part of a linked VVT system or as a stand-alone controller.

Occupancy

The RTU Open's operation depends upon its occupancy state (**Occupied/Unoccupied**). The RTU Open operates continuously in the **Occupied** mode until you configure an occupancy schedule.

An occupancy schedule may be:

- A local schedule configured in the controller using BACview or Field Assistant
- A BACnet schedule configured in i-Vu, networked through an i-Vu Open Router
- A BACnet or local schedule configured for subordinate VVT Zones, networked through an i-Vu Open Router(s) and employing Linkage

To set up occupancy schedules, consult the documentation for your user interface.

NOTE A BACnet schedule, downloaded from i-Vu will overwrite a local schedule that was set up with BACview or Field Assistant.

Occupancy Source - the following settings determine occupancy. See *Unit configuration* (page 59).

Options:

- **Always Occupied** – Controller operates continuously, regardless of any configured schedule
- **BAS On/Off** – Occupancy is set over the network by another device or a third party BAS. Refer to the *RTU Open Integration Guide* for additional instructions in communication protocols.
- **Remote Occ Input** – Controller monitors an input contact connected to one of the available binary inputs configured to receive it. You must set **Unit Configuration > Occupancy Source** to **Remote Occ Input** and one **Input Switch Configuration** to **Remote Occupancy**.

Supply fan

The RTU Open supply fan may be configured for one of three **Fan Modes**:

- **Auto** - The fan cycles on/off in conjunction with heating or cooling
- **Continuous** - The fan runs continuously during occupancy and intermittently during unoccupied periods with heating or cooling
- **Always On** - The fan runs continuously regardless of occupancy or calls for heating and cooling

Occupancy can be determined by Linkage, BACnet schedules, BAS schedules, or in response to a remote occupancy switch.

A **Unit Start Delay** is used when transitioning from **Unoccupied** to **Occupied**. A **Fan Off Delay** allows the supply fan to continue operating after heating or cooling stops.

If the following alarms are active, the fan turns off immediately, regardless of the occupancy state or demand:

- **Fire Shutdown**
- **Safety chain**
- **SAT** alarm
- **SPT** alarms

The RTU Open does not include smoke-control functions such as smoke-purge, zone-pressurization, or smoke-ventilation. Each of these modes require a field-designed circuit to operate the following, as required by local fire codes:

- RTU supply fan
- RTU economizer
- RTU power exhaust

The RTU Open may be configured to accept a **Supply Fan Status** input to provide proof the supply fan is operating. When enabled, a loss or lack of fan status will stop heating and cooling operation.

A **Supply Fan Alarm Service Timer** function is available to track the number of supply fan run hours and generate an alarm when the accumulated runtime exceeds the set threshold.

Cooling

The RTU Open's application and configuration determines the specific cooling sequence. The RTU Open can control up to two stages of cooling with an additional output for a reversing valve (heat pump applications).

The following conditions must be true for the cooling algorithm to operate:

- **Outdoor Air Temperature** is greater than the **Cooling Lockout Temperature** setpoint
- The indoor fan has been on for at least 30 seconds
- The unit has a valid **Supply Air Temperature** input
- The unit has a valid **Space Temperature** input
- Heat mode is not active and the time guard between modes has expired
- Economizer is active and open > 85% with SAT > (**Minimum Cooling SAT** + 5 °F) and SPT > **Effective Cooling Setpoint** + 0.5 °F, or the Economizer is unavailable

The cooling relays are controlled by the Cooling Control PID Loop and Cooling Stages Capacity algorithm. They calculate the desired number of stages needed to satisfy the space by comparing the **Space Temperature** to the:

- **Effective Occupied Cooling Setpoint** when occupied
- **Effective Unoccupied Cooling Setpoint** when unoccupied

When the cooling algorithm preconditions have been met, the compressors are energized in stages, as applicable. Anti-recycle timers are employed to protect the equipment from short-cycling. There are fixed three-minute minimum on-times, and five-minute off-times for each compressor output.

During compressor operation, the RTU Open may reduce the number of active stages if the rooftop supply air temperature falls below the **Minimum Cooling SAT Setpoint**. A compressor staged off in this fashion may be started again after the normal time-guard period has expired, if the **Supply Air Temperature** has increased above the **Minimum Cooling SAT Setpoint**.

Compressor 2 Service Alarm Timer functions are available (one for each stage of compression). This function tracks the number of compressor run hours and generates an alarm when the accumulated runtime exceeds the threshold set by the adjustable compressor service alarm timers.

Economizer

The RTU Open provides an analog economizer output for rooftop units with economizer dampers. Economizer dampers may be used to provide free cooling and indoor air quality control when outside air conditions are suitable.

The following conditions must be true for economizer operation:

- The **Outdoor Air Temperature** is less than the **Space Temperature** and less than the **Economizer High OAT Lockout Temp** setpoint
- The indoor fan has been on for at least 30 seconds
- The unit has a valid **Supply Air Temperature** input
- The unit has a valid **Space Temperature** input

If any of the preceding conditions are not true, the economizer will be set to the **Vent Dmpr Pos / DCV Min Pos** setpoint.

If all preceding conditions are true, the economizer PID loop will modulate the damper from the **Vent Dmpr Pos / DCV Min Pos** setpoint.

The economizer moves to the **Vent Dmpr Pos / DCV Min Pos** setpoint if the SAT falls below the **Minimum Cooling SAT** (+ 5 °F).

Power Exhaust

The RTU Open may enable and disable an exhaust fan, based on either the controller's occupancy or its economizer damper position.

If **Continuous Occupied Exhaust** is **Yes**, the **Power Exhaust** binary output (BO-8) is energized while the RTU Open is occupied and de-energized when unoccupied.

If **Continuous Occupied Exhaust** is **No**, the **Power Exhaust** binary output (BO-8) is energized when the economizer damper output exceeds the **Power Exhaust Setpoint** value (default = 50%). The output remains energized until the economizer output falls below the **Power Exhaust Setpoint** value by a fixed hysteresis of 10%.

Unoccupied Free Cooling

Unocc Free Cool Enable allows rooftop equipment with an economizer damper to utilize outdoor air for free cooling during unoccupied periods.

The following conditions must be true for unoccupied free cooling to operate:

- **Unocc Free Cool Enable** set to **Enable**
- The system is unoccupied
- The outside air temperature is below the **Economizer High OAT Lockout Temp** setpoint
- The outside air temperature is less than the space temperature
- **Enthalpy** (if enabled) is **Low**

When the RTU Open schedule is unoccupied and the space temperature rises at least 1° above the **Occupied Cooling Setpoint**, the supply fan starts. The economizer damper opens as necessary to cool the space. The RTU Open continues to operate in this mode until the space is satisfied or the outside air conditions are no longer suitable for free cooling.

Optimal Start

The RTU Open may utilize **Optimal Start**. **Optimal Start** adjusts the effective setpoints to achieve the occupied setpoints by the time scheduled occupancy begins. The Optimal Start recovery period may begin as early as 4 hours prior to occupancy. The algorithm works by moving the unoccupied setpoints toward the occupied setpoints. The rate at which the setpoints move is based on the outside air temperature, design temperatures, and capacities.

The following conditions must be true for unoccupied free cooling to operate:

- On the **Properties** page > **Equipment** tab > **Configuration** > **Setpoints** > **Optimal Start**, the **Default Value** must be set greater than **0** and less than or equal to **4** (**0.00** disables **Optimal Start**).
- The system is unoccupied

NOTE If the Open controller does not have a valid outside air temperature, then a constant of 65° F is used. This value is not adjustable.

The actual equation that the controller uses to calculate **Optimal Start** is nonlinear. An approximation of the result is shown below.

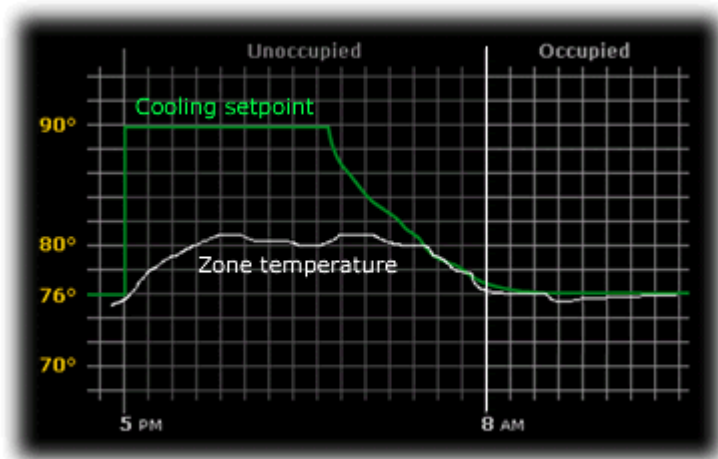

To change Optimal Start settings:

- 1 In the navigation tree, select the equipment that you want to change.
- 2 Click **Properties** page > **Equipment** tab > **Configuration** > **Setpoints**.

Enthalpy control

You may use an enthalpy switch to indicate the suitability of outdoor air for economizer cooling. You can use either an outdoor air or differential enthalpy switch. A differential enthalpy switch has a sensing device in both the outdoor and return air streams. A differential enthalpy switch indicates when outside air is cooler than the return air, and is available for economizer cooling. If no enthalpy switch is configured, a network point (Object Name: oae) is available. This point is displayed in i-Vu and BACview as **Enthalpy** (BACnet).

The sequence of operation for economizer cooling is the same with or without an enthalpy switch, except that an enthalpy switch imposes one more validation on the suitability of outside air for economizer cooling. An **Enthalpy Status** that is **High** disables the economizer and the outside air damper goes to its minimum position. An **Enthalpy Status** that is **Low** enables the economizer if a call for cooling exists and the remaining preconditions are met.

Indoor Air CO2

Indoor Air CO2 is controlled on rooftop equipment with an economizer. **Indoor Air CO2** sequence is enabled by installing an air quality (CO2) sensor. A CO2 sensor may be terminated at the RTU Open, or a subordinate zone controller, when part of a zoned system.

An outdoor air quality sensor may also be installed and terminated at the RTU Open, but it is not required. When an outdoor air quality sensor is not installed, the algorithm uses 400ppm as the fixed outdoor air CO2 level.

The following conditions must be true for the **Indoor Air CO2** algorithm to operate:

- The system is occupied
- The supply fan has been started for at least 30 seconds
- The CO2 sensor has a valid reading

As the air quality within the space changes, the minimum position of the economizer damper changes, which allows more or less outdoor air into the space, depending on the relationship of the indoor air CO2 level to the differential setpoint.

The **Indoor Air CO2** algorithm calculates a minimum position value using a PID loop. The CO2 minimum damper position is then compared against the **Vent Dmpr Pos / DCV Min Pos** setpoint and the greatest value becomes the final minimum damper position of the economizer output.

The degree to which the outside air damper may be opened by the **Indoor Air CO2** algorithm is limited by the **DCV Max Vent Damper Pos** setpoint, which is adjustable between ten and sixty percent (10 – 60%).

Heating

The specific heating sequence is determined by the controller's application and configuration. The RTU Open controls up to two stages of gas or electric heating with an additional output for a **Reversing Valve** (Heat Pump applications).

The following conditions must be true for the heating algorithm to operate:

- The **Outdoor Air Temperature** is less than the **Heating Lockout Temperature** setpoint
- The indoor fan has been ON for at least 30 seconds
- The unit has a valid **Supply Air Temperature** input
- The unit has a valid **Space Temperature** input
- Neither Cool mode nor economizer are active and the time guard between modes has expired

The heating relays are controlled by the Heating Control PID Loop and Heating Stages Capacity algorithm, which calculate the desired number of stages to satisfy the space by comparing the **Space Temperature** to the:

- **Effective Occupied Heating Setpoint** when occupied
- **Effective Unoccupied Heating Setpoint** when unoccupied

When the heating algorithm preconditions have been met, the heating is energized in stages. Anti-recycle timers are employed to protect the equipment from short-cycling. There are fixed one minute minimum on and off times for each heating output.

During heating operation, the RTU Open may reduce the number of active stages if the rooftop **Supply Air Temperature** exceeds the **Maximum Heating SAT** setpoint. A heat stage turned off in this fashion may be started again after the normal time-guard period has expired, if the **Supply Air Temperature** has decreased below the **Maximum Heating SAT** setpoint.

Heat Pump operation

The RTU Open can control heat pumps **HP O/B** and **Y1/W1**.

HP O/B provides a separate output (BO-7) to control a reversing valve. The reversing valve control may be configured to be energized with a call for heating (**B**), or energized with a call for cooling (**O**).

The sequence of operations are as previously described for heating and cooling except that the **Y1** and **Y2** outputs are compressor outputs, energizing mechanical heating or cooling, depending on the state of the reversing valve. **W1** and **W2** are used for auxiliary heat. Up to two stages are available.

Selection **Y1/W1** is for heat pumps that do not require a **O** terminal to energize the reversing valve. The sequences of operations are as described for *Heating* (page 47) and *Cooling* (page 43). The reversing valve output is not utilized in this application. **W1** and **W2** are used for auxiliary heat. Up to two stages are available.

Dehumidification

The RTU Open provides occupied and unoccupied dehumidification on units that are equipped with the Carrier Humidi-MiZer™ option from the factory. This requires a space relative humidity sensor or a humidistat for control.

The following conditions must be true for the dehumidification control to operate:

- The **Outside Air Temperature** is greater than the **Cooling Lockout Temperature** setpoint
- The **Indoor Fan** has been ON for at least 30 seconds
- The unit has a valid **Supply Air Temperature** input
- The unit has a valid **Space Temperature** input
- The unit has a valid **Space Relative Humidity Sensor** or **Humidistat** input
- Heat mode is not active and the time guard between modes has expired

When using a relative humidity sensor to control dehumidification, occupied and unoccupied dehumidification setpoints are used.

When using a humidistat, the setpoints are not used. The humidistat indicates a high-humidity condition.

When a high indoor relative humidity condition is indicated and the above conditions are satisfied, the RTU Open enters the dehumidification mode, energizing the Humidi-MiZer™ output.

The mode continues until the space relative humidity falls below the active setpoint by a 5% fixed Hysteresis when a humidity sensor is used, or when there is no longer a call for dehumidification where a humidistat is used.

See the base unit / Humidi-MiZer™ operations manual for additional information.

Demand Limit

The RTU Open may employ a demand limit strategy. Demand limiting in the RTU Open works through setpoint expansion. The controller's heating and cooling setpoints are expanded in steps or levels. The degree to which the setpoints are expanded is defined by the **Demand Level Setpoints**.

Each **Demand Level** (1 through 3) adjusts the heating and cooling setpoints outwards. By default, **Demand 1** yields a 1° expansion, **Demand 2** yields a 2° expansion, and **Demand 3** yields a 4° expansion.

The BACnet **Demand Limit** variable sets the desired level of setpoint expansion in the receiving controller. **Level 0** leaves the standard occupied and unoccupied heating and cooling setpoints in effect. Levels 1 through 3 expands occupied heating and cooling setpoints.

Door switch

A **Door Contact** may be configured on any unused binary input. A typical application is an occupancy sensor mounted within the space served by a single zone rooftop. **Door Contact** disables mechanical cooling and electric or gas heating, when active. Economizer cooling, if available, continues to operate.

Remote occupancy

Remote occupancy may be configured on any unused binary input channel. A typical application is a remote contact, controlled by a third party, to set the controller's occupied mode. The **Remote Occupancy** function requires both an input configured for **Remote Occupancy**, and **Occupancy Source** set to **Remote Occ Input** to operate.

Once configured, the controller will operate in the occupied or unoccupied mode, as determined by the state of the **Remote Occupancy** input.

Fire Shutdown

Fire Shutdown may be configured on Binary Input 5. A typical application involves a smoke detector or fire shutdown contact, which, when active, immediately shuts down equipment operation.

Compressor Safety

Compressor Safety may be configured on Binary Input 3. A compressor safety tripped indicator circuit is available on most Carrier rooftop equipment.

A **Compressor Safety Alarm** is shown on **Properties** page > **Equipment** tab > **Alarms** and indicates that the equipment requires attention.

Cooling, heating, and supply fan outputs are not interrupted except where the RTU Open is configured for Heat Pump operation. When configured for Heat Pump, and in the heating mode, a compressor safety fault will cause the available stages of electric heating to be enabled in place of mechanical heating.

Normal operation resumes when the compressor safety circuit is de-energized.

Fan Status

Fan Status may be configured on any unused binary input channel. A typical application would be an airflow switch, current sensing relay, or other device that provides a supply fan running verification.

Enabling this function displays the supply fan's status on the equipment graphic.

If the controller loses fan status during operation, heating and cooling are disabled, the economizer damper (if available) is closed, and an alarm for loss of status is indicated.

If the fan status is on when the controller is commanding the fan off, the unit remains in the off state. An alarm is generated indicating that the fan is running when it should be off.

Filter Status

Filter status may be configured on any unused binary input channel. A typical application is a differential pressure switch that senses the pressure drop across a filter bank.

When the pressure across the filter bank exceeds the setpoint of the differential pressure switch, the **Filter** status is displayed as **Dirty** on the controller graphic. An alarm indicates a dirty filter.

Alarms

NOTE Some of the **Alarms** functions described in this section will only be visible on the **Properties** page > **Equipment** tab > **Alarms** when the appropriate inputs are configured. Alarms are not initiated when the input is not configured.

Safety Chain - You may use the RTU Open's safety chain circuit to shut down the unit for a safety condition. Examples: Low or High Temperature Cutouts (Freezestat / Firestat). See *To wire inputs and outputs* (page 14) for additional wiring instructions. This alarm indicates the safety chain circuit (Input 4) is open. Cooling, heating, and supply fan operation stop after appropriate time guards. Normal operation resumes when the safety chain circuit is complete.

Fire Shutdown - You may configure the RTU Open to accept a **Fire Shutdown** contact on Input 5. Examples: Smoke detectors or fire shutdown relays. This alarm indicates this device (Input 5) has tripped. Cooling, heating, and supply fan operation immediately stop. Reset fire shutdown contact to resume normal operation.

Compressor Safety - You may configure the RTU Open to monitor the base unit's compressor safety circuit. This alarm indicates the base unit's compressor safety circuit is energized. Cooling, heating, and supply fan outputs are not interrupted except when the RTU Open is configured for Heat Pump. Normal operation resumes when the compressor safety circuit is de-energized.

If the Heat Pump is in the heating mode, it will automatically replace the compressor stage(s) with the equivalent number of auxiliary heat stages, as available.

- If it's a Carrier Heat Pump, there is only one auxiliary heat stage output and the staging is done by the machine itself, if it's two-stage gas or electric.

- For a non-Carrier Heat Pump, when configured for two stages of aux heat and two compressors, Compressor 1 is replaced by Aux Heat Stage 1 and Compressor 2 is replaced by Aux Heat Stage 2.

The compressor output stays on when the safety alarm is present. For cooling, the alarm indicates the compressors are down. See *Heat Pump operation* (page 48) for further information.

Space Temp Sensor – This alarm indicates an invalid sensor condition in a physically connected space temperature sensor (SPT Sensor/T5*). Cooling, heating, and supply fan operation stop after the appropriate time guards. Normal operation resumes when the controller detects a valid sensor.

Supply Air Temp Sensor – This alarm indicates a shorted or open circuit in the SAT input. Cooling, heating, and supply fan operation stops after the appropriate time guards. Normal operation resumes when the controller detects a valid sensor.

Outdoor Air Temp Sensor Alarm - This alarm indicates a shorted or open circuit in the OAT input. Cooling, heating, and supply fan operation continues. OAT lockouts will not operate while the sensor is in alarm. Normal operation resumes when the controller detects a valid sensor.

Space Relative Humidity Sensor - This alarm indicates if the mA input at the associated channel falls below 3.5 mA or rises above 21 mA. Cooling, heating, and supply fan operation continues, however, the controller's Humidi-MiZer™ binary output is disabled until the fault condition is corrected.

IAQ Sensor - The RTU Open generates an **IAQ Sensor** alarm if the mA input at the associated channel falls below 3.5 mA or rises above 21 mA. Cooling, heating, and supply fan operation continues. However, the controller's IAQ control function is disabled until the fault condition is corrected.

OAQ Sensor - The RTU Open generates an **OAQ Sensor** alarm if the mA input at the associated channel falls below 3.5 mA or rises above 21 mA. Cooling, heating, and supply fan operation continues. However, the controller's IAQ control function uses 400ppm as the fixed outdoor air CO2 level until the fault condition is corrected.

Space Temperature –

- **Occupied** - The RTU Open generates a **Low Space Temperature** alarm if the space temperature falls below the lower limit of the blue color bar. A **High Space Temperature** alarm is generated if the space temperature rises above the upper limit of the orange color bar.
- **Unoccupied** An unoccupied low space temperature alarm is generated when the space temperature falls below the **Alarm Configuration > Unoccupied Low SPT Alarm Limit**. An unoccupied high space temperature alarm is generated when the space temperature rises above the **Alarm Configuration > Unoccupied High SPT Alarm Limit**.

The following values are related to the **Space Temperature** alarm:

- **Alarming Temperature** – This variable displays the value of the space temperature that is in alarm and is only visible when the space temperature is in an alarm state.
- **Alarm Limit Exceeded** – This variable displays the value of the alarm setpoint that is exceeded by the alarming space temperature and is only visible when the space temperature is in an alarm state.

High Supply Air Temperature – The RTU Open generates this alarm when the supply air temperature exceeds the **Alarm Configuration > High SAT Alarm Limit** setpoint for 5 minutes. This alarm is inhibited until the RTU has been running for 30 minutes to allow for system stabilization after startup.

Low Supply Air Temperature - The RTU Open generates this alarm when the supply air temperature falls below the **Alarm Configuration > Low SAT Alarm Limit** setpoint for 5 minutes. This alarm is inhibited until the RTU has been running for 30 minutes to allow for system stabilization after startup.

Setpoint Slider – The RTU Open generates this alarm when an open circuit is detected at Input 11 and the RTU Open **Configuration > Unit Configuration > Input Configuration > Space sensor type** is set to T56. Note that only an open circuit results in an alarm. A short across this input offsets the setpoints negatively by the amount configured in the **Unit Configuration > Setpoint Adjustment Range**.

Switch Configuration - The RTU Open generates this alarm when any two of the **Unit Configuration > Input Functions 3, 5, 8, or 9** are configured identically. Neither input may work reliably and downstream control may be affected, depending on the function duplicated. The alarm clears and normal control is restored when the input function duplication is corrected.

Analog Input Configuration - The RTU Open generates this alarm when the **Unit Configuration > Input**

Functions 1 and 2 are configured identically. Neither input may work reliably and downstream control may be affected, depending on the function duplicated. The alarm clears and normal control is restored when the input function duplication is corrected.

High Space Relative Humidity - The RTU Open generates this alarm when the space humidity exceeds the **Alarm Configuration > High Space Humidity Alarm Limit** setpoint for 10 minutes. This alarm is inhibited until the RTU runs for 15 minutes to allow for system stabilization after startup.

Low Space Relative Humidity - The RTU Open generates this alarm when the space humidity falls below the **Alarm Configuration > Low Space Humidity Alarm Limit** setpoint for 5 minutes. This alarm is inhibited until the RTU runs for 5 minutes to allow for system stabilization after startup.

High CO2 - The RTU Open generates this alarm when the space CO2 level exceeds the **Alarm Configuration > Occupied High CO2 Alarm Limit** setpoint for 1-minute. This alarm will be inhibited until the RTU has been running for 2-minutes to allow for system stabilization after startup.

Supply Fan Runtime - The RTU Open generates a this alarm when the accumulated runtime exceeds the **Unit Configuration > Supply Fan Service Alarm Timer** value (when not set to 0). This alarm is most commonly used to indicate an equipment maintenance interval is due. The supply fan runtime accumulator may be reset by setting the **Maintenance > Reset Supply Fan Runtime Alarm** to **Clear**, and then back to **Run** – acknowledging each selection by clicking the **OK** button when it appears. Setting **Unit Configuration > Supply Fan Service Timer** value to **0** disables the supply fan runtime alarm function.

Compressor 1 Runtime - The RTU Open generates this alarm when the accumulated runtime exceeds the **Unit Configuration > Compressor 1 Service Alarm Timer** value (when not set to 0). This alarm is most commonly used to indicate an equipment maintenance interval is due. The **Compressor 1 Runtime** accumulator may be reset by setting the **Maintenance > Reset Comp 1 Runtime Alarm** to **Clear**, and then back to **Run** – acknowledging each selection by clicking the **OK** button when it appears. Setting **Unit Configuration > Compressor 1 Service Timer** value to **0** disables the **Compressor 1 Runtime** alarm function.

Compressor 2 Runtime - The RTU Open generates this alarm when the accumulated runtime exceeds the **Unit Configuration > Compressor 2 Service Alarm Timer** value (when not set to 0). This alarm is most commonly used to indicate an equipment maintenance interval is due. The Compressor 2 runtime accumulator may be reset by setting the **Maintenance > Reset Comp 2 Runtime Alarm** to **Clear**, and then back to **Run** – acknowledging each selection by clicking the **OK** button when it appears. Setting **Unit Configuration > Compressor 2 Service Timer** value to **0** disables the Compressor 2 runtime alarm function. Note that this function is unavailable if the **Service Configuration > Compressor States** value is not set to **Two Stages**.

Filter - The RTU Open generates this alarm when the accumulated runtime exceeds the **Unit Configuration > Filter Service Alarm Timer** value (when not set to 0). This alarm is most commonly used to indicate a filter replacement is due. Reset the filter service runtime accumulator by setting the **Maintenance > Reset Filter Runtime Alarm** to **On**, back to **Off**, and clicking the **OK** button after each setting. Setting **Unit Configuration > Filter Service Alarm Timer** value to **0** disables the filter service alarm function.

Airside Linkage Alarm - An RTU Open may act as an air source in a zoned system. Carrier systems utilize a function called Linkage™ to pass data between a master zone and its air source via an MS/TP network connection. When the RTU Open is part of a linked system, it will indicate an airside linkage alarm if it loses communications with its linkage master or if it receives invalid data.

Linkage

The RTU Open may serve as an air source to an Open Variable Volume Terminal (VVT) system. When the RTU Open is part of a VVT system and the controllers are wired together to form a network, the controllers may use a method of communication known as Linkage™. Linkage is a method by which an air source and its subordinate zone terminals exchange data to form a coordinated HVAC system. The system's air source controller, zone controllers, and bypass controller are linked so that their data exchange can be managed by one zone controller configured as the VVT Master.

The VVT Master gathers the following information from the slave zone controllers:

- occupancy status
- setpoints
- zone temperature
- relative humidity
- CO₂ level
- damper position
- optimal start data

The VVT Master performs mathematical calculations and algorithms on the data and then sends the composite information to the air source. The VVT Master receives information from the air source such as mode, supply air temperature, and outside air temperature, and passes that information to all linked controllers.

NOTE The following paragraphs describe the interaction between the air source (RTU Open) and its subordinate zones. Additional information regarding Open Zoned Systems may be found in the *VVT Zone and VVT Bypass Controller Installation Guides*.

The VVT Master determines system operation by prioritizing heating and cooling requirements from all the zones based on their occupancy and demand. The VVT Master scans the system continuously to determine if any zones are occupied. Occupied zones are a higher priority than unoccupied zones. The VVT Master evaluates all the occupied zones' heating or cooling demands and sends a request to the air source (RTU Open) for:

- Cooling, if the number of occupied zones with cooling demands exceeds the number of occupied zones with heating demands, and the demand is greater than or equal to the number of configured **Linkage Callers**.
- Heating, if the number of occupied zones with a heating demand exceeds or is equal to the number of **Linkage Callers**.

If no zones are occupied or no occupied zones require heating or cooling, the VVT Master performs the evaluation described above for the unoccupied zones.

The VVT Master then gathers the following information and sends it to the air source (RTU Open):

- The system mode
- The setpoints and zone temperature from the zone with the greatest demand for the requested air source mode (heating or cooling). (This zone is called the reference zone.)
- The system occupancy status
- Most open damper position from any zone
- RH and CO₂ values (if applicable)

The air source responds by sending the air source mode, supply air temperature, and outside air temperature. The air source verifies the mode by comparing its supply air temperature to the space temperature received through Linkage. See the air source documentation for operation and parameters used to verify its mode. This verification allows the VVT system to determine if the desired air source mode is actually being provided. For example, if the VVT Master sends a request for heating and the air source does not have heat or it's heat has failed, the air source's actual mode indicates that and it's current mode is sent to the zones so that they can control accordingly.

The system remains in that mode until all zones of that demand are satisfied or until a fixed 30 minute mode reselect timer causes a forced re-evaluation of the system. If there is no demand for the opposite mode, the reselect timer starts again and the current mode continues until all zones are satisfied or until the reselect timer expires, repeating the process. If there is a demand for the opposite mode, the VVT Master sends the reference zone's space temperature and setpoints to the air source and restarts the reselect timer. The air source re-evaluates its demand based on the new information and goes to the Vent mode until the new mode can be verified as described above. The amount of time this takes is determined by the air source's operating parameters.

The VVT Master continuously evaluates the system and updates the air source with the most current system demand. Based on the evaluation, the reference zone can change from one zone to another. The evaluation process continues until there is no demand from any zone or the 30 minute timer causes a re-evaluation of the system conditions.

If no heating or cooling is required or the current air source mode is satisfied, the VVT Master calculates the weighted average of the occupied and unoccupied heating and cooling setpoints. It also calculates a zone temperature that is midway between the setpoints (occupied or unoccupied based on the system's current occupancy status). This information, plus the occupancy status, is sent to the air source so that its current mode is disabled and the unit ceases heating or cooling operation. If the system is occupied, the air source fan and OA damper, if applicable, operate to maintain proper ventilation.

Linkage Air Source Modes

In a linked system, the air source determines its operating mode and qualifies that mode based on its own **Supply Air Temperature** (SAT). The following modes can be sent by the air source depending on its configuration:

- **Off** – Air source fan is off
- **Fan Only** – Air source fan is on and providing ventilation (neutral SAT) without heating or cooling
- **Economizer Cooling** – Air source fan is on and providing cooling, using economizer only
- **Cooling** – Air source fan is on and cooling is provided by economizer and mechanical cooling
- **Heating** – Air source fan is on and heating is provided (gas or electric)
- **Dehumidification** – Air source fan is on and Humidi-MiZer™ is active
- **Test** – The RTU Open **Service Test** mode is active
- **Shutdown** – Air source fan is off due to Safety Chain, Fire Shutdown, or invalid SAT sensor
- **Unocc Free Cooling** – Air source fan is on, with the economizer providing cooling while unoccupied

Troubleshooting

If you have problems mounting, wiring, or addressing the RTU Open, contact Carrier Control Systems Support.

Serial number

If you need the RTU Open's serial number when troubleshooting, the number is on:

- a sticker on the back of the main controller board
- a Module Status report (modstat) from your user interface

LED's

The LED's on the RTU Open show the status of certain functions.

If this LED is on...	Status is...
Power	The RTU Open has power
Rx	The RTU Open is receiving data from the network segment
Tx	The RTU Open is transmitting data over the network segment
DO#	The binary output is active

The **Run** and **Error** LED's indicate controller and network status.

If Run LED shows...	And Error LED shows...	Status is..
2 flashes per second	Off	Normal
2 flashes per second	2 flashes, alternating with Run LED	Five minute auto-restart delay after system error
2 flashes per second	3 flashes, then off	The controller has just been formatted
2 flashes per second	On	Exec halted after frequent system errors or control programs halted
5 flashes per second	Off	Firmware transfer in progress, Boot is running
7 flashes per second	7 flashes per second, alternating with Run LED	Ten second recovery period after brownout

If Run LED shows...	And Error LED shows...	Status Is..
14 flashes per second	14 flashes per second, alternating with Run LED	Brownout
On	On	Failure. Try the following solutions: <ul style="list-style-type: none"> • Turn the RTU Open off, then on. • Format the RTU Open.* • Download memory to the RTU Open. • Replace the RTU Open.

*Formatting the controller may result in lost information and should only be done under the guidance of Carrier Control Systems Support.

Replacing the RTU Open's battery

The RTU Open's 10-year Lithium CR2032 battery provides a minimum of 10,000 hours of data retention during power outages.

CAUTION Power must be **ON** to the RTU Open when replacing the battery, or your date, time, and trend data will be lost.

- 1 Remove the battery from the controller, making note of the battery's polarity.
- 2 Insert the new battery, matching the battery's polarity with the polarity indicated on the RTU Open.

Compliance

FCC Compliance

This equipment has been tested and found to comply with the limits for a Class A digital device, pursuant to Part 15 of the FCC Rules. These limits are designed to provide reasonable protection against harmful interference when the equipment is operated in a commercial environment. This equipment generates, uses, and can radiate radio frequency energy and, if not installed and used in accordance with the instruction manual, may cause harmful interference to radio communications. Operation of this equipment in a residential area is likely to cause harmful interference in which case the user will be required to correct the interference at his own expense.

CAUTION Changes or modifications not expressly approved by the responsible party for compliance could void the user's authority to operate the equipment.

CE Compliance

WARNING This is a Class A product. In a domestic environment, this product may cause radio interference in which case the user may be required to take adequate measures.

BACnet Compliance

BACnet® is a registered trademark of ASHRAE. ASHRAE does not endorse, approve or test products for compliance with ASHRAE standards. Compliance of listed products to requirements of ASHRAE Standard 135 is the responsibility of the BACnet manufacturers Association (BMA). BTL® is a registered trademark of the BMA.

Appendix A: RTU Open Points/Properties

Status

Navigation: i-Vu / Field Assistant: **Properties > Equipment > Status**
 BACview: **HOME > STATUS**

Point Name/Description	Range
System Mode – The controller's current operating status.	R: Disabled Test Run
Operating Mode – The controller's current operating mode.	R: Off Fan Only Economizer Cooling Heating Dehumidification Test Shutdown Unocc Free Cooling (NTFC)
Supply Fan Status – The current fan status if an input is configured for Fan Status .	R: Off/Running
Space Temperature - Prime Variable – The space temperature value currently used for control.	R: -56 to 245 °F
Supply Air Temperature – The current supply air temperature.	R: -56 to 245 °F
Outdoor Air Temperature – The outdoor air temperature value used for control.	R: -56 to 245 °F
Space Relative Humidity – The current space relative humidity if Configuration > Unit Configuration > Input 1 (or 2) Function is set to Space RH Sensor .	R: 0 to 100%rh
Indoor Air CO2 – The current indoor air CO ₂ concentration if the Configuration >Unit Configuration > Input 1 (or 2) Function is set to IAQ Sensor .	R: 0 to 5000ppm
Outdoor Air CO2 – The current outdoor air CO ₂ concentration if the Configuration >Unit Configuration >Input 1 (or 2) Function is set to OAQ Sensor .	R: 0 to 5000ppm
Economizer Output – The current economizer output with respect to the outdoor air damper (if equipped).	R: 0 to 100% Open

Unit Configuration

Navigation:

i-Vu / Field Assistant:

Properties > Equipment > Configuration > Unit Configuration

BACview:

HOME > CONFIG > UNIT

Point Name/Description	Default/Range
<p>Fan Mode – The supply fan's operating mode.</p> <p>Options: Auto - The fan cycles on/off in conjunction with heating or cooling. Continuous - The fan runs continuously during occupancy & intermittently during unoccupied periods with heating or cooling. Always On - The fan runs continuously regardless of occupancy or calls for heating and cooling.</p>	<p>D: Continuous</p> <p>R: Auto Continuous Always On</p>
<p>Unit Start Delay – The amount of time the controller delays starting up after receiving a start command.</p>	<p>D: 5 sec</p> <p>R: 0 to 30 sec</p>
<p>Fan Off Delay – How long the supply fan runs after receiving a valid stop command.</p>	<p>D: 90 sec</p> <p>R: 0 to 180 sec</p>
<p>Minimum Cooling SAT – In cooling mode, the cooling outputs are controlled so that the supply air temperature does not drop below this value.</p>	<p>D: 50 °F</p> <p>R: 45 to 75 °F</p>
<p>Maximum Heating SAT – In heating mode, the heating outputs are controlled so the supply air temperature does not rise above this value.</p>	<p>D: 120 °F</p> <p>R: 85 to 150 °F</p>
<p>Vent Dmpr Pos / DCV Min Pos – The minimum outdoor air damper position maintained during occupied periods.</p>	<p>D: 50% Open</p> <p>R: 0 to 100% Open</p>
<p>DCV Max Vent Damper Pos – The maximum outdoor air damper position allowed while DCV is active.</p>	<p>D: 50% Open</p> <p>R: 10 to 60% Open</p>
<p>Supply Fan Service Alarm Timer – A Supply Fan Runtime alarm is generated when the supply fan run hours exceed this value. Set to 0 to disable.</p>	<p>D: 600 hr</p> <p>R: 0 to 9999 hr</p>
<p>Compressor 1 Service Alarm Timer – A Compressor 1 Runtime alarm is generated when the compressor 1 run hours exceed this value. Set to 0 to disable.</p>	<p>D: 0 hr</p> <p>R: 0 to 9999 hr</p>
<p>Compressor 2 Service Alarm Timer – A Compressor 2 Runtime alarm is generated when the compressor 2 run hours exceed this value. Set to 0 to disable.</p>	<p>D: 0 hr</p> <p>R: 0 to 9999 hr</p>
<p>Filter Service Alarm Timer – The amount of time the fan will run before generating a Filter Alarm. Set to 0 to disable the alarm and reset accumulated fan hours.</p>	<p>D: 600 hr</p> <p>R: 0 to 9999 hr</p>
<p>Pushbutton Override – Enables or disables the use of a pushbutton override from a local space temperature sensor.</p>	<p>D: Enable</p> <p>R: Disable/Enable</p>
<p>Cooling Lockout Temp – The outdoor air temperature at which cooling is inhibited.</p>	<p>D: 45 °F</p> <p>R: 0 to 80 °F</p>
<p>Economizer High OAT Lockout – The outdoor air temperature at which economizer cooling is inhibited.</p>	<p>D: 75 °F</p> <p>R: 55 to 80 °F</p>

Point Name/Description	Default/Range
HP Rev Cycle Lockout Temp – The outdoor air temperature at which reverse cycle heating is locked out. Requires that the unit is configured as a Heat Pump.	D: -3 °F R: -20 to 30 °F
Heating Lockout Temperature – The outdoor air temperature at which heating is inhibited.	D: 65 °F R: 35 to 150 °F
Unocc Free Cool Enable – Enable to allow the unit to use economizer to provide unoccupied free cooling (NTFC).	D: Disable R: Disable/Enable
Occupancy Source - The method that the controller uses to determine occupancy. Options: Always Occupied = Controller operates continuously as occupied. BACnet Schedule = Controller follows a schedule set up in i-Vu or Field Assistant. BAS On/Off = Occupancy is set over the network by another device or a third party BAS. Remote Occ Input =Occupancy is set by a remote contact.	D: Always Occupied R: Always Occupied BACnet Schedule BAS On/Off Remote Occ Input
Input Configuration	
Input 1 Function – The type of sensor (4-20 mA) connected to terminals J4 – 4, 5, & 6.	D: No Sensor R: No Sensor IAQ Sensor OAQ Sensor Space RH Sensor
Input 2 Function – The type of sensor (4-20 mA) connected to terminals J4 – 1, 2, & 3.	D: No Sensor R: No Sensor IAQ Sensor OAQ Sensor Space RH Sensor
Input 3 Function – The usage of Input 3. You must also set Input 3 Switch Configuration . Options: No Function – The input is not used. Compressor Safety – Safety device status. Fan Status – Proves supply fan operation. Filter Status – Indicates a dirty filter. Remote Occupancy – Sets occupancy using a hardware contact. Door Contact – Sets occupancy using a hardware contact.	D: Compressor Safety R: No Function Compressor Safety Fan Status Filter Status Remote Occupancy Door Contact
Input 3 Switch Configuration – The normal (de-energized) state for the set of contacts terminated at Input	D: NO R: NO/NC (normally open/normally closed)
Input 5 Function – The usage of Input 5. You must also set Input 5 Switch Configuration . Options: No Function – The input is not used. Fire Shutdown – Fire Safety device status. Inhibits operation when tripped. Fan Status – Proves supply fan operation. Filter Status – Indicates a dirty filter. Remote Occupancy – Sets occupancy using a hardware contact. Door Contact – Sets occupancy using a hardware contact.	D: Fire Shutdown R: No Function Fire Shutdown Fan Status Filter Status Remote Occupancy Door Contact
Input 5 Switch Configuration – The normal (de-energized) state for the set of contacts terminated at Input	D: NC R: NO/NC (normally open/normally closed)

Point Name/Description	Default/Range
<p>Input 8 Function – The usage of Input 8. You must also set Input 8 Switch Configuration.</p> <p>Options: No Function – The input is not used. Enthalpy Switch – Indicates enthalpy status (high or low). Fan Status – Proves supply fan operation. Filter Status – Indicates a dirty filter. Remote Occupancy – Sets occupancy using a hardware contact. Door Contact – Sets occupancy using a hardware contact.</p>	<p>D: Enthalpy Switch</p> <p>R: No Function Enthalpy Switch Fan Status Filter Status Remote Occupancy Door Contact</p>
<p>Input 8 Switch Configuration – The normal (de-energized) state for the set of contacts terminated at Input</p>	<p>D: NO</p> <p>R: NO/NC (normally open/normally closed)</p>
<p>Input 9 Function – The usage of Input 9. You must also set Input 9 Switch Configuration.</p> <p>Options: No Function – The input is not used. Humidistat – Indicates high humidity condition. Fan Status – Proves supply fan operation. Filter Status – Indicates a dirty filter. Remote Occupancy – Sets occupancy using a hardware contact. Door Contact – Sets occupancy using a hardware contact.</p>	<p>D: Humidistat</p> <p>R: No Function Humidistat Fan Status Filter Status Remote Occupancy Door Contact</p>
<p>Input 9 Switch Configuration – The normal (de-energized) state for the set of contacts terminated at Input</p>	<p>D: NO</p> <p>R: NO/NC (normally open/normally closed)</p>
<p>Space sensor type - The type of local space temperature sensor.</p>	<p>D: T55</p> <p>R: T55 T56 (Use for T59) SPT Sensor None</p>
<p>T5x Override Duration – If using a T55, T56, or T59 sensor, this is the amount of time that the controller runs in the occupied mode when a user presses the sensor's override button for 1 to 10 seconds.</p>	<p>D: 1 hr</p> <p>R: 0 to 24 hours</p>
<p>Sensor Calibration</p>	
<p>Space Temp Calibration – A calibration offset value to allow the local space temperature sensor to be adjusted to match a calibrated standard measuring the temperature in the same location.</p>	<p>D: 0 °F</p> <p>R: -9.9 to 10 °F</p>
<p>Supply Air Temp Calibration – A calibration offset value to allow the supply air temperature sensor to be adjusted to match a calibrated standard measuring the temperature in the same location.</p>	<p>D: 0 °F</p> <p>R: -9.9 to 10 °F</p>
<p>Outside Air Temp Calibration – A calibration offset value to allow the outside air temperature sensor to be adjusted to match a calibrated standard measuring the temperature in the same location.</p>	<p>D: 0 °F</p> <p>R: -9.9 to 10 °F</p>

Setpoints

Navigation: i-Vu / Field Assistant: **Properties > Equipment > Configuration > Setpoints**
 BACview: **HOME > CONFIG > SETPOINT**

Select a color band on the setpoint graph to see the current setpoints in the **Heating** and **Cooling** fields. See setpoint descriptions below.

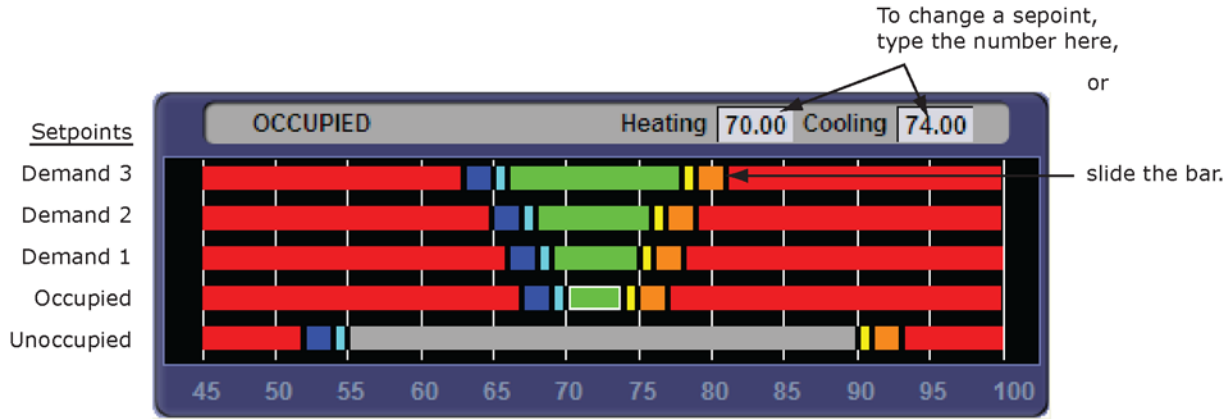

Occupied Setpoints

The occupied setpoints described below are the setpoints under normal operating conditions. The Demand Level 1–3 setpoints apply if demand limiting is used.

Demand limiting is a cost-saving strategy to reduce energy consumption. The strategy expands the occupied heating and cooling setpoints when the system reaches one of 3 levels of consumption. With the expanded setpoints, the equipment works less, thereby saving energy. By default, Demand Level 1 expands the occupied heating and cooling setpoints by 1 °F, Demand Level 2 by 2 °F, and Demand Level 3 by 4 °F. If the occupied heating or cooling setpoints change, the (effective) demand level setpoints automatically change by the same amount. See *Sequence of Operation* (page 42) for more information.

Point Name/Description	Default Range: -40 to 245 °F			
	Occupied	Demand Level		
		1	2	3
Occupied Heating – Green The heating setpoint the controller maintains while in occupied mode.	70 °F	69 °F	68 °F	66 °F
Occupied Cooling – Green The cooling setpoint the controller maintains while in occupied mode.	74 °F	75 °F	76 °F	78 °F
Occupied Heating 1 – Light Blue The space temperature must be less than the Occupied Heating 1 setpoint for the VVT Master to consider the zone a heating caller in a linked system. In a single-zone application, the heating requirement begins as soon as the space temperature falls below the Occupied Heating setpoint. We recommend that the Occupied Heating 1 value be set no less than 0.5 °F below the Occupied Heating setpoint.	69 °F	68 °F	67 °F	65 °F
Occupied Heating 2 – Dark Blue The space temperature must be less than the Occupied Heating 2 setpoint to generate a low space temperature alarm. We recommend that this value be set no less than 0.5 °F below the Occupied Heating 1 setpoint.	68 °F	67 °F	66 °F	64 °F

Point Name/Description	Default Range: -40 to 245 °F			
	Occupied	Demand Level		
		1	2	3
Occupied Cooling 1 – Yellow The space temperature must be greater than the Occupied Cooling 1 setpoint for the VVT Master to consider the zone a cooling caller in a linked system. In a single-zone application, the cooling requirement begins as soon as the space temperature exceeds the Occupied Cooling setpoint. We recommend that the Occupied Cooling 1 value be set no less than 0.5 °F above the Occupied Cooling setpoint.	75 °F	76 °F	77 °F	79 °F
Occupied Cooling 2 – Orange The space temperature must be greater than the Occupied Cooling 2 setpoint to generate a high space temperature alarm. We recommend that this value be set no less than 0.5 °F above the Occupied Cooling 1 setpoint.	76 °F	78 °F	78 °F	81 °F

Unoccupied Setpoints

Point Name/Description	Default/Range
Unoccupied Heating – Gray The heating setpoint the controller maintains while in unoccupied mode.	D: 55 °F R: 45 to 100 °F
Unoccupied Cooling – Gray The cooling setpoint the controller maintains while in unoccupied mode.	D: 90 °F R: -40 to 245 °F
Unoccupied Heating 1 – Light Blue The space temperature must be less than the Unoccupied Heating 1 setpoint for the VVT Master to consider the zone an unoccupied heating caller in a linked system. In a single-zone application, the unoccupied heating requirement begins as soon as the space temperature falls below the Unoccupied Heating setpoint. We recommend that the Unoccupied Heating 1 value be set no less than 0.5 °F below the Unoccupied Heating setpoint.	D: 54 °F R: -40 to 245 °F
Unoccupied Heating 2 – Dark Blue The space temperature must be less than the Unoccupied Heating 2 setpoint to generate an unoccupied low space temperature alarm. We recommend that this value be set no less than 0.5 °F below the Unoccupied Heating 1 setpoint.	D: 52 °F R: -40 to 245 °F
Unoccupied Cooling 1 – Yellow The space temperature must be greater than the Unoccupied Cooling 1 setpoint for the VVT Master to consider the zone an unoccupied cooling caller in a linked system. In a single-zone application, the unoccupied cooling requirement begins as soon as the space temperature exceeds the Unoccupied Cooling setpoint. We recommend that the Unoccupied Cooling 1 value be set no less than 0.5 °F above the Unoccupied Cooling setpoint.	D: 91 °F R: -40 to 245 °F
Unoccupied Cooling 2 – Orange The space temperature must be greater than the Unoccupied Cooling 2 setpoint to generate an unoccupied high space temperature alarm. We recommend that this value be set no less than 0.5 °F above the Unoccupied Cooling 1 setpoint.	D: 93 °F R: -40 to 245 °F

Point Name/Description	Default/Range
Heating Capacity – Used for Optimal Start, this is the rate at which the zone temperature changes when the heating system runs at full capacity to maintain designed occupied heating setpoint.	D: 5°F/hr R: 0 to 120°F/hr
Heating Design Temp – The geographically-based outdoor air temperature at which the heating system must run constantly to maintain comfort. This information is available in ASHRAE publications and most design references.	D: 0°F R: -100 to 150°F
Cooling Capacity – Used for Optimal Start, this is the rate at which the zone temperature changes when the cooling system runs at full capacity to maintain designed occupied cooling setpoint.	D: 5°F/hr R: 0 to 140°F/hr
Cooling Design Temp – The geographically-based outdoor air temperature at which the cooling system must run constantly to maintain comfort. This information is available in ASHRAE publications and most design references.	D: 100°F R: -100 to 150°F
<p>Hysteresis – The desired difference between the temperature at which the zone color changes as the zone temperature departs from the acceptable range between the heating and cooling setpoints (green) into the Cooling 1 (yellow) or Heating 1 (light blue) and the temperature at which the zone color changes back to the acceptable range between the heating and cooling setpoints.</p> <p>For example, the following graph shows the zone color that results as the zone temperature departs from and returns to the acceptable range in a zone with the following settings:</p> <ul style="list-style-type: none"> • Color Change Hysteresis = .5° (applies as the temperature returns to the acceptable range) • Occupied cooling setpoint = 76° • Occupied heating setpoint = 70° 	D: 0.5°F R: 0 to 120°F

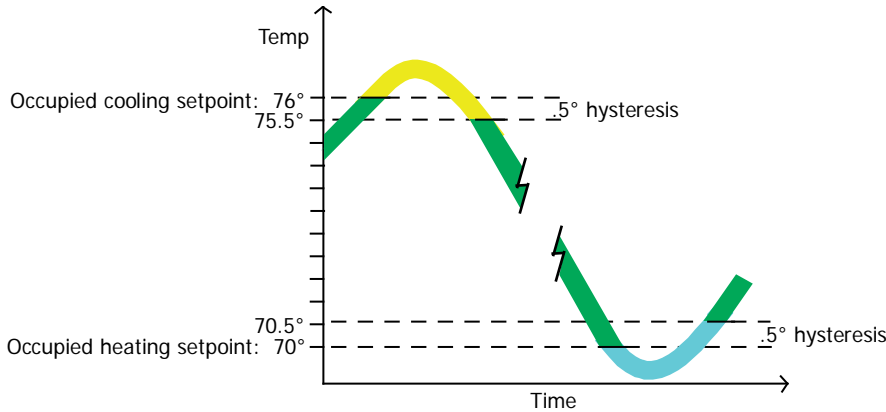

Effective Setpoints

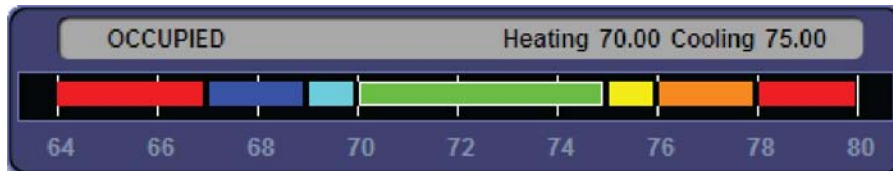

The Effective Setpoints graph shows the current occupied or unoccupied setpoints. If occupied, these values are the current programmed setpoints plus the offset of any setpoint adjustment that may be in affect. If unoccupied, the values are the programmed unoccupied setpoints.

Point Name/Description	Default/Range
Heating – (Occupied or Unoccupied, depending on mode) The current programmed Heating setpoint adjusted by any offset that may be in effect.	R: 0 to 120 °F
Cooling – (Occupied or Unoccupied, depending on mode) The current programmed Cooling setpoint adjusted by any offset that may be in effect.	R: 0 to 120 °F
Optimal Start – The earliest time, prior to occupancy, at which the Optimal Start function may begin to adjust the effective setpoints to achieve the occupied setpoints by the time scheduled occupancy begins. Enter 0 to disable Optimal Start.	D: 4 hr R: 0 to 4 hr
Occ Relative Humidity Setpoint – The percentage of relative humidity in the space during occupancy that will energize BO - 6 (Humidi-MiZer™).	D: 60%rh R: 0 to Unoccupied RH Control Setpoint
Unocc Relative Humidity Setpoint – The percentage of relative humidity in the space during the unoccupied time period that starts the unit and energizes BO - 6 (Humidi-MiZer™).	D: 95% R: 30 to 100%
DCV Max Ctrl Setpoint – The design difference between indoor and outdoor CO2 levels.	D: 650ppm R: 0 to 9999 ppm
Power Exhaust Setpoint - The outside air damper position at which the controller energizes the Power Exhaust relay. Configuration >Service Configuration > Economizer Exists must be set to Yes , and Configuration >Service Configuration > Continuous Occupied Exhaust must be set to No .	D: 50% Open R: 20 to 90% Open

Alarm Configuration

Navigation: i-Vu / Field Assistant: **Properties > Equipment > Configuration > Alarm Configuration**
 BACview: **HOME > CONFIG > ALARMS**

Point Name/Description	Default/Range
Space Temperature Alarm	
Occupied Alarm Hysteresis – This value is added to the occupied high effective setpoint and subtracted from the occupied low effective setpoint to establish the occupied high and low limits that the space temperature must exceed before an occupied SPT alarm is generated. The alarm returns to normal when the space temperature drops below the high effective setpoint or rises above the low effective setpoint.	D: 3 °F R: 0 to 20 °F
Alarm Delay (min/deg) – Determines the amount of delay before an occupied space temperature alarm is generated when the controller transitions to the occupied mode. The delay time equals this value multiplied by the difference between the sensor temperature and occupied alarm setpoint plus 15 minutes.	D: 10 minutes R: 0 to 60 minutes
Unoccupied Low SPT Alarm Limit – The value that the space temperature must drop below to generate a Space Temperature Alarm in the unoccupied mode. There is a fixed hysteresis of 1 ° F for return to normal.	D: 45 °F R: -60 to 250 °F

Point Name/Description	Default/Range
Unoccupied High SPT Alarm Limit – The value that the space temperature must exceed to generate a Space Temperature Alarm in the unoccupied mode. There is a fixed hysteresis of 1° F for return to normal.	D: 90° F R: -60 to 250° F
Supply Air Temperature Alarm	
Low SAT Alarm Limit – The value that the supply air temperature must drop below to generate a Supply Air Temp Alarm . There is a fixed hysteresis of 1° F for return to normal.	D: 45° F R: -60 to 250° F
High SAT Alarm Limit – The value that the supply air temperature must exceed to generate a Supply Air Temp Alarm . There is a fixed hysteresis of 1° F for return to normal.	D: 120° F R: -60 to 250° F
Space Humidity Alarm	
Low Space Humidity Alarm Limit – The value that the relative humidity must drop below to generate a Low Space Humidity Alarm. Requires a space relative humidity transmitter and Configuration >Unit Configuration >Input 1 (or 2) Function set to Space RH Sensor .	D: 30% R: 0 – 99 %
High Space Humidity Alarm Limit – The value that the relative humidity must rise above to generate a High Space Humidity Alarm. Requires a space relative humidity transmitter and Configuration >Unit Configuration >Input 1 (or 2) Function set to Space RH Sensor .	D: 70% R: 0 – 99 %
IAQ/Ventilation Alarm	
Occupied High CO2 Alarm Limit – The value that the CO ₂ sensor must exceed to generate an IAQ Alarm in the occupied mode. There is a fixed hysteresis of 100ppm for return to normal. Requires a space CO ₂ sensor and Configuration >Unit Configuration >Input 1 (or 2) Function set to IAQ Sensor .	D: 1200ppm R: 0 to 9999 ppm

Service Configuration

Navigation: i-Vu / Field Assistant: **Properties > Equipment > Configuration > Service Configuration**
 BACview: **HOME > CONFIG > SERVICE**

Point Name/Description	Default/Range
Unit Type – The type of equipment that the RTU Open is controlling. Options: Heat/Cool – Standard rooftop air handling unit. HP O/B Ctrl – Heat Pump application, uses reversing valve output to control heating and cooling. HP Y1/W1 Ctrl – Carrier Heat Pump application only.	D: Heat/Cool R: Heat/Cool HP O/B Ctrl HP Y1/W1 Ctrl

Point Name/Description	Default/Range
Compressor Stages – The number of mechanical cooling stages.	D: One Stage R: One Stage Two Stages
Economizer Exists – Set to Yes to enable economizer control for units equipped with an economizer damper.	D: No R: No/Yes
Heat Type – The type of heating that the unit has.	D: Electric R: Electric/Gas
Number Of Heat Stages – The number of heat stages.	D: 2 R: 1 /2 /0 (no heating)
Continuous Occupied Exhaust – Configures the exhaust fan control strategy (BO-8). If Yes , the power exhaust runs continuously in occupied mode and is off in unoccupied mode. If No , the power exhaust is controlled by the Power Exhaust Setpoint .	D: No R: No/Yes
Indoor CO2 Sensor Value @min (ma) – The CO2 value that corresponds to a 4mA input at the appropriate input channel.	D: 0ppm R: 0 to 9999 ppm
Indoor CO2 Sensor Value @max (ma) – The CO2 value that corresponds to a 20mA input at the appropriate input channel.	D: 2000 ppm R: 0 to 9999 ppm
Outdoor CO2 Sensor Value @min (ma) – The CO2 value that corresponds to a 4 mA input at the appropriate input channel.	D: 0ppm R: 0 to 9999 ppm
Outdoor CO2 Sensor Value @max (ma) – The CO2 value that corresponds to a 20 mA input at the appropriate input channel.	D: 2000 ppm R: 0 to 9999 ppm
System Space Temperature – The network space temperature value that the controller is using for control (if applicable).	D: -999.00 °F R: N/A
System Cool Demand Level – The system cool demand level being received over the network.	D: 0.00 R: 0 - 3
System Heat Demand Level – The system heat demand level being received over the network.	D: 0.00 R: 0 - 3
System Outside Air Temperature – Allows the outside air temperature value to be network readable when enabled. Requires that controller is equipped with an outdoor air temperature sensor.	D: -999.0 °F R: N/A
Service Test	
Service Test – Enable to stop automatic control so you can test the controller's outputs. Automatically resets to Disable after 1 hour.	D: Disable R: Disable/Enable
Fan Test – Enable to test the controller's fan speeds. Sequences fan from low to high speed and operates at each speed for 1 minute. Resets to Disable when complete. Service Test must be set to Enable .	D: Disable R: Disable/Enable
Compressor 1 Test – Enable to test the controller's compressor 1 output. Service Test must be set to Enable .	D: Disable R: Disable/Enable

Point Name/Description	Default/Range
Compressor 2 Test – Enable to test the controller's compressor 2 output. Service Test must be set to Enable .	D: Disable R: Disable/Enable
Heat 1 Test – Enable to test the controller's heat 1 output. Service Test must be set to Enable .	D: Disable R: Disable/Enable
Heat 2 Test – Enable to test the controller's heat 2 output. Service Test must be set to Enable .	D: Disable R: Disable/Enable
Reversing Valve Test – Enable to test the controller's reversing valve output. Service Test must be set to Enable .	D: Disable R: Disable/Enable
Dehumidification Test – Enable to test the controller's humidifier output. Service Test must be set to Enable .	D: Disable R: Disable/Enable
Power Exhaust Test – Enable to test the controller's exhaust fan output. Service Test must be set to Enable .	D: Disable R: Disable/Enable
Economizer Test – Set to a value between 0 and 100% to test the controller's economizer output. Service Test must be set to Enable .	D: 0% Open R: 0 to 100% Open
Analog Output 2 Test – Analog Output 2 (0-10 Vdc) is currently unused.	D: 0% R: 0 to 100%

Maintenance

Navigation: i-Vu / Field Assistant: **Properties > Equipment > Maintenance**
 BACview: **HOME > MAINT**

Point Name/Description	Default/Range
Unit	
Occupancy Status – The controller's occupancy status as determined by a network schedule, a local schedule, or a timed override.	R: Occupied/Unoccupied
Space Temp Sensor – The source of the controlling space temperature value. Options: Sensor Failure – No valid space temperature or sensor status = failed. SPT Sensor – An SPT sensor is connected to the controller's Rnet port. T55/56 – A T55, T56, or T59 sensor is connected to the controller's J20 terminals. Network – A network temperature sensor is bound to the controller's space temperature AV. Airside Linkage – The space temperature from a linked terminal. Locked Value – The controller's space temperature input has been manually locked at a value.	R: Sensor Failure SPT Sensor T55/T56 Network Airside Linkage Locked Value
Safety Chain Feedback - Indicates a completed circuit from J1, 1 to J1, 9. This circuit is typically used for safety devices that immediately stop unit operation when tripped.	R: Off/Run Enabled

Point Name/Description	Default/Range
Fire Shutdown – Shutdown indicates that a fire shutdown is in effect.	R: Run Enabled/ Shutdown
Compressor Safety Status – Trouble indicates that the compressor safety device has tripped.	R: Normal/Trouble
Enthalpy Status – The enthalpy status determined by an enthalpy switch.	R: High/Low
Humidistat Input Status – The humidity status determined by a humidistat.	R: High/Low
Reset Supply Fan Runtime Alarm – Set to Clear to reset Supply Fan Runtime to 0.	D: Run R: Run/Clear
Reset Comp 1 Runtime Alarm – Set to Clear to reset Compressor 1 Runtime to 0.	D: Run R: Run/Clear
Reset Comp 2 Runtime Alarm – Set to Clear to reset Compressor 2 Runtime to 0.	D: Run R: Run/Clear
Reset Filter Runtime Alarm – Set to On to reset Filter Runtime to 0.	D: Off R: Off/On
Occupancy	
BAS On/Off – Determines the occupancy state of the controller and can be set over the network by another device or third party BAS. Options: Inactive – Occupancy is determined by a configured schedule. Occupied – The controller is always in the occupied mode. Unoccupied – The controller is always in the unoccupied mode.	D: Inactive R: Inactive Occupied Unoccupied
Schedules – The controller's occupancy status based on the schedule.	R: Occupied/Unoccupied
Pushbutton Override – Active indicates if a user pushed the sensor's override button to override the occupancy state.	R: Off/Active
Override Time Remaining – The amount of time remaining in an override period.	R: 0 to 240 minutes
Runtime	
Supply Fan Runtime – The total number of hours that the supply fan relay has been energized since the runtime was last reset to 0 using Reset Supply Fan Runtime Alarm .	R: ___ hr
Compressor 1 Runtime – The total number of hours that the Compressor 1 relay has been energized since the runtime was last reset 0 using Reset Comp 1 Runtime Alarm .	R: ___ hr
Compressor 2 Runtime – The total number of hours that the Compressor 2 relay has been energized since the runtime was last reset using Reset Comp 2 Runtime Alarm .	R: ___ hr
Filter Runtime – The total number of hours that the unit has been operating since the runtime was last reset to 0 using Reset Filter Runtime Alarm .	R: ___ hr

Alarms

Navigation: i-Vu / Field Assistant:
BACview:

Properties > Equipment > Alarms
HOME > ALARM

Point Name/Description	Range
Safety Chain – Indicates if the Safety Chain circuit trips.	R: Normal/Alarm
Fire Shutdown – Indicates if the Fire Shutdown circuit trips.	R: Normal/Alarm
Compressor Safety – Indicates if the Compressor Safety circuit trips.	R: Normal/Alarm
Space Temp Sensor – Indicates if the space temperature sensor fails.	R: Normal/Alarm
Supply Air Temp Sensor – Indicates if the supply air temperature sensor fails.	R: Normal/Alarm
Outdoor Air Temp Sensor Alarm – Indicates if the outdoor air temperature sensor fails.	R: Normal/Alarm
Space Relative Humidity Sensor – Indicates if the space relative humidity sensor fails.	R: Normal/Alarm
IAQ Sensor – Indicates if the indoor air quality (CO ₂) sensor fails.	R: Normal/Alarm
OAQ Sensor – Indicates if the outdoor air quality (CO ₂) sensor fails.	R: Normal/Alarm
Space Temperature – Indicates if the space temperature sensor exceeds the high or low alarm limit.	R: Normal/Alarm
Alarming Temperature – The value of the alarming space temperature sensor.	R: The sensor's range
Alarm Limit Exceeded – The alarm limit that the alarming space temperature sensor exceeded.	R: -60 to 250 °F
High Supply Air Temperature Alarm Limit. – Indicates if the supply air temperature exceeds the High SAT Alarm Limit.	R: Normal/Alarm
Low Supply Air Temperature Alarm Limit. – Indicates if the supply air temperature falls below the Low SAT Alarm Limit.	R: Normal/Alarm
Setpoint Slider – Indicates if the T56 sensor's setpoint slider potentiometer fails.	R: Normal/Alarm
Switch Configuration – Indicates if a duplicate configuration exists for two or more binary Input 3, 5, 8, & 9 Functions.	R: Normal/Alarm
Analog Input Configuration – Indicates if a duplicate configuration exists at the analog Input 1 & 2 Functions.	R: Normal/Alarm
High Space Relative Humidity Space Humidity Alarm Limit. – Indicates if the space relative humidity exceeds the High Space Humidity Alarm Limit.	R: Normal/Alarm
Low Space Relative Humidity Space Humidity Alarm Limit. – Indicates if the space relative humidity falls below the Low Space Humidity Alarm Limit.	R: Normal/Alarm
High CO2 – Indicates if the indoor CO ₂ level rises above the Occupied High CO2 Alarm Limit.	R: Normal/Alarm
Supply Fan Runtime Service Alarm Timer. – Indicates if the supply fan runtime exceeds the value of the Supply Fan Service Alarm Timer.	R: Normal/Alarm
Compressor 1 Runtime Compressor 1 Service Alarm Timer. – Indicates if the compressor 1 runtime exceeds the value of the Compressor 1 Service Alarm Timer.	R: Normal/Alarm

Point Name/Description	Range
Compressor 2 Runtime – Indicates if the compressor 1 runtime exceeds the value of the Compressor 2 Service Alarm Timer .	R: Normal/Alarm
Filter – Indicates a dirty filter condition when the filter runtime exceeds the value of the Filter Service Alarm Timer or in response to a filter status switch binary input.	R: Clean/Dirty
Airside Linkage Alarm – Indicates if Linkage fails in a zoned system using Linkage.	R: Normal/Alarm

Linkage

Navigation: i-Vu / Field Assistant: **Properties > Equipment > Linkage**
 BACview: **Properties > Equipment > Linkage**

Point Name/Description	Range
Linkage Collector – Allows access to the Collector's details.	
Airside Linkage Status – If Active , the controller is part of a linked system. If Not Active , the controller is a stand-alone device.	R: Active/Not Active
If Airside Linkage Status is Active , the following provide information received from the VVT Master (as applicable): Occupancy Status Space Temperature Occupied Cooling Setpoint Occupied Heating Setpoint Unoccupied Cooling Setpoint Unoccupied Heating Setpoint Indoor Air CO2 Space Relative Humidity	

I/O Points

The values shown on the **I/O Points Properties** page are the raw values at the I/O objects and may not match values shown on status displays that are affected by control program logic.

i-Vu users logged in as **Power User** and above are able to edit various parameters associated with the input channels and the display names for all channels.

We strongly recommend that you leave these parameters at their defaults. The RTU Open is not a programmable controller. I/O can only be used for the purpose designed in the equipment control program. Modifying these parameters may result in unpredictable equipment control.

See *Wiring inputs and outputs* (page 12) for more information. This table lists each of the I/O Channels, their functions, associated hardware, and terminal numbers.

Navigation: i-Vu / Field Assistant: **Properties > I/O Points**
 BACview: **N/A**

Point Name/Description
Space Temp – The value of the Optional SPT (Rnet) sensor. Also allows i-Vu & Field Assistant users access to sensor configuration. See <i>Carrier Sensors Installation Guide</i> for additional details.
Input 1 – Input Channel 1; 4 - 20 mA only. User-configurable for IAQ, OAQ, or Space RH.
Input 2 – Input Channel 2; 4 - 20 mA only. User-configurable for IAQ, OAQ, or Space Relative Humidity.
Input 6 – Input Channel 6; 10K Thermistor only. Supply Air Temperature.
Input 7 – Input Channel 7; 10K Thermistor only. Outside Air Temperature.
Input 10 – Input Channel 10; 10K Thermistor only. Space Temperature (T55, 56, 59).
Input 11 – Input Channel 11; 100K Potentiometer only. Setpoint adjust (T56, 59).
slidepot voltage reading – Input Channel 11; used to detect an open circuit (faulty Setpoint adjustment mechanism).
Input 3 – Input Channel 3; Dry Contact only. User-configurable for No Function, Compressor Safety, Fan Status, Filter Status, Remote Occupancy, or Door Contact.
Input 4 – Input Channel 4; Dry Contact only. Safety Chain.
Input 5 – Input Channel 5; Dry Contact only. User-configurable for No Function, Fire Shutdown, Fan Status, Filter Status, Remote Occupancy, or Door Contact.
Input 8 – Input Channel 8; Dry Contact only. User-configurable for No Function, Enthalpy, Fan Status, Filter Status, Remote Occupancy, or Door Contact.
Input 9 – Input Channel 9; Dry Contact only. User-configurable for No Function, Humidistat, Fan Status, Filter Status, Remote Occupancy, or Door Contact.
Sensor Invalid – Reflects the status of the Space Temp (Rnet) input. On = Space Temp invalid, Off = Space Temp valid.
ao 1 – Analog Output Channel 1; jumper selectable.
ao 2 – Analog Output Channel 2; 0 - 10 Vdc. Not Utilized.
relay 1 – Binary Output 1; Fan (G) Output.
relay 2 – Binary Output 2; Heat 2 (W2) Output.
relay 3 – Binary Output 3; Heat 1 (W1) Output.
relay 4 – Binary Output 4; Cool 2 (Y2) Output.
relay 5 – Binary Output 5; Cool 1 (Y1) Output.
relay 6 – Binary Output 6; Humidi-MiZer™ Output.
relay 7 – Binary Output 7; Reversing Valve Output.
relay 8 – Binary Output 8; Power Exhaust Output.

Appendix B: Single Point Linkage and Device Address Binding

Single Point Linkage

The RTU Open receives data from other Open controllers when they are installed as part of an Open system. The data transfer may take the form of Single Point Linkage (SPL), which is automatic, or Device Address Binding, which you must configure.

Currently, the RTU Open implements Single Point Linkage for 3 variables: Refer to configuration section - complete list - make list to system system configuration1.....might be different for RTU - might be unit config

- **System Cool Demand Level**
- **System Heat Demand Level**
- **System Outside Air Temperature**

Network Points for which SPL has been implemented are displayed in i-Vu and Field Assistant on the **Properties** page > **Network Points** tab.

The following example involves outside air temperature. **System Heat & Cool Demand Level** behaves similarly, except that their usage involves a specific application loaded on a Universal Controller Open. See *UC Open Installation Guide* for additional information. In either case, note that the BACnet type and instance numbers specified in the **Address** field of these variables have been predefined.

Network variables for which SPL is used are easily identified on the **Properties** page > **Network Points** tab. The asterisk in the BACnet address invokes the SPL function. These addresses cause the controller to issue a BACnet “who has” command for this variable. The controller binds to the closest of the first five devices from which it receives a valid response.

Name	Type	Value	Locked	Default Value	Com Enabled	COV Enable	Refresh Time (mm:ss)	Address	Error	Present Value
System Outside Air Temperature (Primary)	(AN)2	62.00	<input type="checkbox"/>	-999	<input checked="" type="checkbox"/>		10:00	bacnet://*AV:80001	0 No Error, bound to DEV:1610151, AV:80001	62
System Outside Air Temperature (Secondary)								bacnet://*AV:80001	0 No Error, bound to DEV:1610151, AV:80001	62

Address containing * (asterisk) denotes Single Point Linkage

Indicates successful binding
Predefined Type and Instance Number for Outside Air Temperature

Device Address Binding

As described previously, **Device Address Binding** allows the RTU Open to receive data from other Open controllers when they are connected by a network. You must configure this method.

Currently, the RTU Open allows **Device Address Binding** (DAB) only for **System Space Temperature**.

Network Points on which DAB may be implemented are displayed in i-Vu and Field Assistant on the **Properties** page > **Network Points** tab with an undefined BACnet address.

Name	Type	Value	Locked	Default Value	Com Enabled	COV Enable	Refresh Time (min:sec)	Address Search / Replace	Error	Present Value
System Space Temperature	(AN/2)	-999.00	<input type="checkbox"/>	-999	<input checked="" type="checkbox"/>		1:00			
(Primary)								bacnet://	0 No Error	-999
(Secondary)								bacnet://	0 No Error	-999

Undefined BACnet Address

Currently "Unbound"

Index

B

BACnet compliance • 57
 BACnet port • 11
 BT485 • 10

C

Compliance • 57

D

Duct Air Temperature sensor • 22
 Duct sensors
 Duct Air Temperature sensor • 22
 Supply Air Temperature sensor • 21

F

FCC compliance • 57
 Field Assistant • 58

I

i-Vu • 58

L

Linkage • 73

M

Module Status report • 55
 MS/TP network, wiring • 10

P

Points/Properties • 58
 Airside Linkage Alarm • 70
 Airside Linkage Status • 71
 Alarm Delay (min/deg) • 65
 Alarm Limit Exceeded • 70
 Alarming Temperature • 70
 Analog Input Configuration • 70
 Analog Output 2 Test • 65
 BAS On/Off • 68
 Compressor 1 Runtime • 68
 Compressor 1 Runtime alarm • 70
 Compressor 1 Service Alarm Timer • 59
 Compressor 1 Test • 66
 Compressor 2 Runtime • 68
 Compressor 2 Runtime alarm • 70
 Compressor 2 Service Alarm Timer • 59
 Compressor 2 Test • 66
 Compressor Safety alarm • 70
 Compressor Safety Status • 68
 Compressor Stages • 40, 66
 Continuous Occupied Exhaust • 40, 66
 Cooling Capacity • 61
 Cooling Design Temp • 61
 Cooling Lockout Temp • 59
 DCV Max Ctrl Setpoint • 39, 59

DCV Max Vent Damper Pos • 59
 Dehumidification Test • 66
 Economizer Exists • 40, 66
 Economizer High OAT Lockout • 59
 Economizer Output • 58
 Economizer Test • 66
 Enthalpy Status • 68
 Fan Mode • 37, 59
 Fan Off Delay • 59
 Fan Test • 66
 Filter Alarm • 70
 Filter Runtime • 68
 Filter Service Alarm Timer • 59
 Fire Shutdown • 68
 Fire Shutdown alarm • 70
 Heat 1 Test • 66
 Heat 2 Test • 66
 Heat Type • 40, 66
 Heating Capacity • 61
 Heating Design Temp • 61
 Heating Lockout Temperature • 59
 High CO2 alarm • 70
 High SAT Alarm Limit • 65
 High Space Humidity Alarm Limit • 65
 High Space Relative Humidity alarm • 70
 High Supply Air Temperature alarm • 70
 HP Rev Cycle Lockout Temp • 59
 Humidistat Input Status • 68
 Hysteresis • 61
 IAQ Sensor alarm • 70
 Indoor Air CO2 • 58, 71
 Indoor CO2 Sensor Value @max (ma) • 40, 66
 Indoor CO2 Sensor Value @min (ma) • 40, 66
 Input # Function • 37, 59
 Input # Switch Configuration • 37, 59
 LAT Airflow Increase • 58
 Linkage Collector • 71
 Low SAT Alarm Limit • 65
 Low Space Humidity Alarm Limit • 65
 Low Space Relative Humidity alarm • 70
 Low Supply Air Temperature alarm • 70
 Maximum Heating SAT • 59
 Minimum Cooling SAT • 59
 Number of Heat Stages • 40, 66
 OAQ Sensor alarm • 70
 OAT System Sensor • 66
 Occ Relative Humidity Setpoint • 39, 61
 Occupancy Source • 37, 59
 Occupancy Status • 68, 71
 Occupied Alarm Hysteresis • 65
 Occupied Cooling • 39, 61
 Occupied Cooling 1 • 61
 Occupied Cooling 2 • 61
 Occupied Cooling Setpoint • 71
 Occupied Heating • 39, 61
 Occupied Heating 1 • 61
 Occupied Heating 2 • 61
 Occupied Heating Setpoint • 71
 Occupied High CO2 Alarm Limit • 65

- Operating Mode • 58
- Optimal Start • 39, 61
- Outdoor Air CO2 • 58
- Outdoor Air Temp Sensor Alarm • 70
- Outdoor Air Temperature • 58
- Outdoor CO2 Sensor Value @max (ma) • 40, 66
- Outdoor CO2 Sensor Value @min (ma) • 40, 66
- Outside Air Temp Calibration • 59
- Override Time Remaining • 68
- Power Exhaust Setpoint • 39, 61
- Power Exhaust Test • 66
- Pushbutton Override • 59, 68
- Reset Comp 1 Runtime Alarm • 68
- Reset Comp 2 Runtime Alarm • 68
- Reset Filter Runtime Alarm • 68
- Reset Supply Fan Runtime Alarm • 68
- Reversing Valve Test • 66
- Safety Chain alarm • 70
- Safety Chain Feedback • 68
- Schedules • 68
- Service Test • 66
- Setpoint Slider • 70
- Space Relative Humidity • 58, 71
- Space Relative Humidity Sensor alarm • 70
- Space sensor type • 37, 59
- Space Temp Calibration • 59
- Space Temp Sensor • 70
- Space Temp Sensor Alarm • 70
- Space Temperature • 71
- Space Temperature - Prime Variable • 58
- Space Temperature Alarm • 70
- Supply Air Temp Calibration • 59
- Supply Air Temp Sensor alarm • 70
- Supply Air Temperature • 58
- Supply Fan Runtime • 68
- Supply Fan Runtime alarm • 70
- Supply Fan Service Alarm Timer • 59
- Supply Fan Status • 58
- Switch Configuration • 70
- System Cool Demand Level • 66
- System Heat Demand Level • 66
- System Mode • 58
- System Outside Air Temperature • 66
- System Space Temperature • 66
- T5x Override Duration • 59
- Unit Start Delay • 59
- Unit Type • 40, 66
- Unocc Free Cool Enable • 59
- Unocc Relative Humidity Setpoint • 39, 61
- Unoccupied Cooling • 39, 61
- Unoccupied Cooling 1 • 61
- Unoccupied Cooling 2 • 61
- Unoccupied Cooling Setpoint • 71
- Unoccupied Heating • 39, 61
- Unoccupied Heating 1 • 61
- Unoccupied Heating 2 • 61
- Unoccupied Heating Setpoint • 71
- Unoccupied High SPT Alarm Limit • 65
- Unoccupied Low SPT Alarm Limit • 65
- Vent Dmpr Pos / DCV Min Pos • 59

R

- Rnet • 20

- Rnet wiring specifications • 20

S

- Serial number • 55
- SPT sensors • 20
- Supply Air Temperature sensor • 21

T

- temperature sensors
 - Duct Air Temperature sensor • 22
 - SPT sensors • 20
 - Supply Air Temperature sensor • 21
- Troubleshooting • 55

W

- Wiring specifications
 - Network • 11
 - Rnet • 20



CARRIER CORPORATION ©2010

A member of the United Technologies Corporation family · Stock symbol UTX · Catalog No. 11-808-427-01 · 11/19/2010

Free Manuals Download Website

<http://myh66.com>

<http://usermanuals.us>

<http://www.somanuals.com>

<http://www.4manuals.cc>

<http://www.manual-lib.com>

<http://www.404manual.com>

<http://www.luxmanual.com>

<http://aubethermostatmanual.com>

Golf course search by state

<http://golfingnear.com>

Email search by domain

<http://emailbydomain.com>

Auto manuals search

<http://auto.somanuals.com>

TV manuals search

<http://tv.somanuals.com>