

BRINKMANN®

CIMARRON™

Deluxe Outdoor Charcoal/Wood Smoker & Grill

CIMARRON™ limited

Deluxe Outdoor Charcoal/Wood Smoker & Grill

OWNER'S MANUAL
ASSEMBLY & OPERATING INSTRUCTIONS

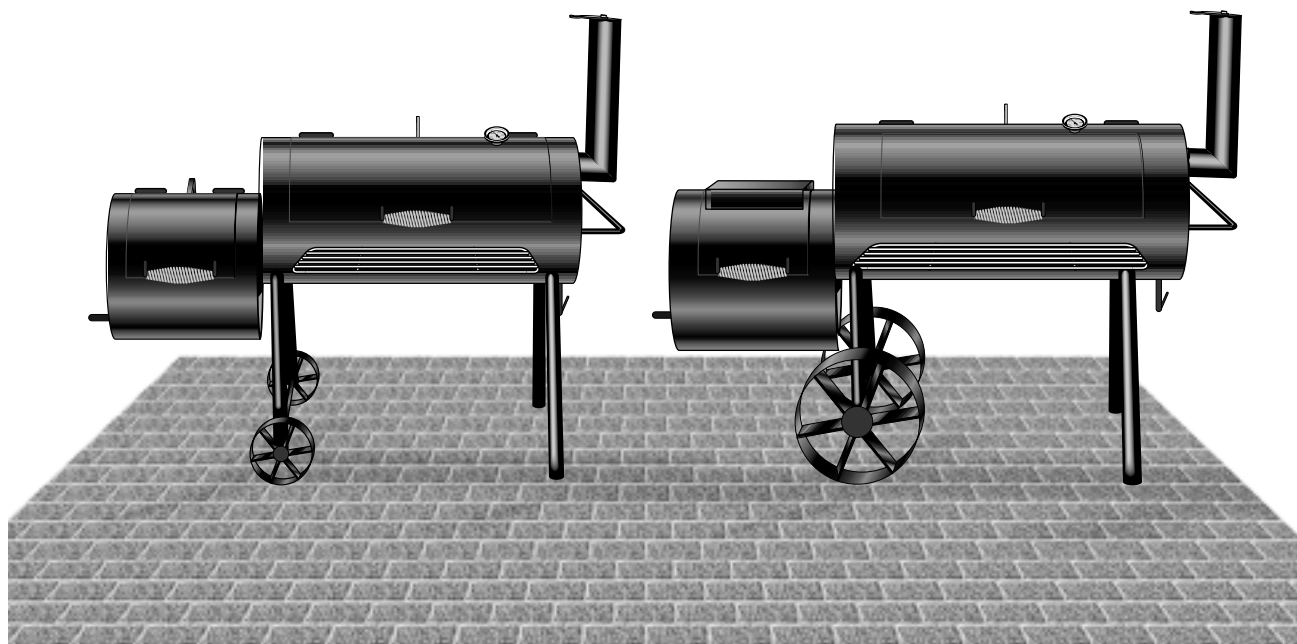

IMPORTANT SAFEGUARDS

WE WANT YOU TO ASSEMBLE AND USE YOUR SMOKER AS SAFELY AS POSSIBLE.

THE PURPOSE OF THIS SAFETY ALERT SYMBOL 

IS TO ATTRACT YOUR ATTENTION TO POSSIBLE HAZARDS AS YOU ASSEMBLE AND USE YOUR SMOKER.

WHEN YOU SEE THE SAFETY ALERT SYMBOL, PAY CLOSE ATTENTION TO THE INFORMATION WHICH FOLLOWS!

 **READ ALL SAFETY WARNINGS AND INSTRUCTIONS CAREFULLY
BEFORE ASSEMBLING AND OPERATING YOUR SMOKER.**

WARNING

- Only use this smoker on a hard, level, noncombustible, stable surface (concrete, ground, etc.) capable of supporting the weight of the smoker. Never use on wooden or other surfaces that could burn.
- Proper clearance of 10 feet between the smoker and combustible material (bushes, trees, wooden decks, fences, buildings, etc.) or construction should be maintained at all times when smoker is in use. Do not place smoker under a roof overhang or other enclosed area.
- For household use only. Do not use this smoker for other than its intended purpose.
- For outdoor use only. Do not operate smoker indoors or in an enclosed area. In windy weather, place smoker in an outdoor area that is protected from the wind.
- Do not use gasoline, kerosene or alcohol for lighting charcoal. Use of any of these or similar products will cause an explosion possibly leading to severe bodily injury.
- We recommend the use of a Charcoal Chimney Starter to avoid the dangers associated with charcoal lighting fluid. If you choose to use charcoal lighting fluid, only use lighting fluid approved for lighting charcoal. Carefully read manufacturer's warnings and instructions on the charcoal lighting fluid and charcoal prior to the use of their product. Store charcoal lighting fluid safely away from smoker.
- When using charcoal lighting fluid, allow charcoal to burn with smoker lids and dampers open until covered with a light ash (approximately 20 minutes). This will allow charcoal lighting fluid to burn off. Failure to do this could trap fumes from charcoal lighting fluid in smoker and may result in a flash fire or explosion when lid is opened.
- Never add charcoal lighting fluid to hot or even warm coals as flashback or explosion may occur causing severe burns.
- Never use charcoal that has been pre-treated with lighter fluid. Use only a high grade plain charcoal or charcoal/wood mixture.
- Never add charcoal and/or wood through firebox side door or firebox air vent. When adding charcoal and/or wood, use extreme caution and follow instructions in "Adding Charcoal/Wood During Cooking" section of this manual.
- When opening lid, make sure it is pushed all the way back so it rests against the lid support bracket. If lid is not resting against the bracket, it could fall back to a closed position and cause bodily injury.
- The firebox lid will be extremely hot during use. Use caution when reaching into or under smoker. Always wear oven mitts or gloves to protect your hands from burns. Avoid touching hot surfaces.
- Place smoker in an area where children and pets cannot come into contact with unit. Close supervision is necessary when smoker is in use. Do not leave smoker unattended when in use.
- Never move smoker when it is in use or when it contains hot coals or ashes.
- Do not store or use smoker near gasoline or other flammable liquids, gases or where flammable vapors may be present.
- Use caution when assembling and operating your smoker to avoid scrapes or cuts from sharp edges of metal parts.
- Whether smoking or grilling, a metal bucket or tin can must be kept under the grease hole at all times to catch grease drippings and or hot embers. Check grease and/or ash level in metal bucket often and empty or change when $\frac{3}{4}$ full. Use extreme caution as the smoker, metal bucket or tin can and its contents will be hot.

WARNING

- When grilling, grease from meat may drip into the charcoal and cause a grease fire. If this should happen close lid, air vent and damper to suffocate the flame. Do not use water to extinguish grease fires.
- Use caution since flames can flare-up when fresh air suddenly comes in contact with fire. When opening the lids, keep hands, face and body a safe distance from hot steam and flame flare-ups.
- To avoid catching fire, do not wear loose clothing or allow hair to hang freely while using smoker.
- Close lids and all dampers to suffocate flame/charcoal when finished cooking.
- Never leave coals and ashes in smoker unattended. Before smoker can be left unattended, remaining coals and ashes must be removed from smoker. Use caution to protect yourself and property. Carefully place remaining coals and ashes in a noncombustible metal container and saturate completely with water. Allow coals and water to remain in metal container 24 hours prior to disposing.
- Do not exceed a temperature of 400°F in cooking chamber. Do not allow charcoal and/or wood to rest on the walls of the firebox and cooking chamber. Doing so will greatly reduce the life of the metal and finish of your smoker. Extinguished coals and ashes should be placed a safe distance from all structures and combustible materials.
- With a garden hose, completely wet the surface beneath and around smoker to extinguish any ashes, coals or embers which may have fallen during the cooking or cleaning process.
- After each use, clean the smoker thoroughly and reapply a light coat of oil to interior to prevent rusting. Cover the smoker to protect it from the weather.
- Use caution when lifting or moving smoker to prevent strains and back injuries. Moving smoker may require the help of an additional person.
- We advise that a fire extinguisher be on hand. Refer to your local authority to determine proper size and type of fire extinguisher.
- Accessory attachments not manufactured by The Brinkmann Corporation for this particular product are not recommended and may lead to personal injury or property damage.
- Store the smoker out of reach of children and in a dry location when not in use.
- Do not attempt to service smoker other than normal maintenance as explained in "After-Use Safety" and "Proper Care & Maintenance" sections on page 13 of this manual. Repairs should be performed by The Brinkmann Corporation only.
- Properly dispose of all packaging material.

USE CAUTION AND COMMON SENSE WHEN OPERATING YOUR SMOKER.

**FAILURE TO ADHERE TO SAFETY WARNINGS AND GUIDELINES IN THIS MANUAL COULD RESULT
IN BODILY INJURY OR PROPERTY DAMAGE.**

SAVE THIS MANUAL FOR FUTURE REFERENCE.

ASSEMBLY INSTRUCTIONS

**⚠ READ ALL SAFETY WARNINGS & ASSEMBLY INSTRUCTIONS CAREFULLY
BEFORE ASSEMBLING OR OPERATING YOUR SMOKER.**

**FOR MISSING PARTS, PLEASE CALL CUSTOMER SERVICE AT 1-800-527-0717.
(PROOF OF PURCHASE WILL BE REQUIRED.)**

Inspect contents of the box to ensure all parts are included and undamaged.

We recommend two people work together when assembling this unit.

The following tools are required to assemble this Cimarron:

- Hammer
- $\frac{7}{16}$ " Wrench or Adjustable Wrench

PARTS LIST:

- ① 1 Cooking chamber with attached Firebox
- ② 1 Air vent butterfly damper
- ③ 1 Smokestack with damper
- ④ 1 Cooking grill (15 $\frac{1}{4}$ " x 12 $\frac{7}{16}$ ")
- ⑤ 1 Cooking grill (15 $\frac{1}{4}$ " x 15")
- ⑥ 1 Charcoal grate (9" x 14")
- ⑦ 1 Front shelf
- ⑧ 2 Legs with endcaps
- ⑨ 2 Legs with axle receivers
- ⑩ 2 5 $\frac{1}{2}$ " wagon wheels (with Cimarron) OR
2 16" wagon wheels (with Cimarron Limited)
- ⑪ 1 Firebox door latch
- ⑫ 1 Firebox rake
- ⑬ 1 Temperature gauge
- ⑭ 1 End handle
- ⑮ 1 Axle rod

Parts Bag Contains:

- 4 $\frac{3}{4}$ " Washers
- 2 $\frac{5}{8}$ " Axle caps

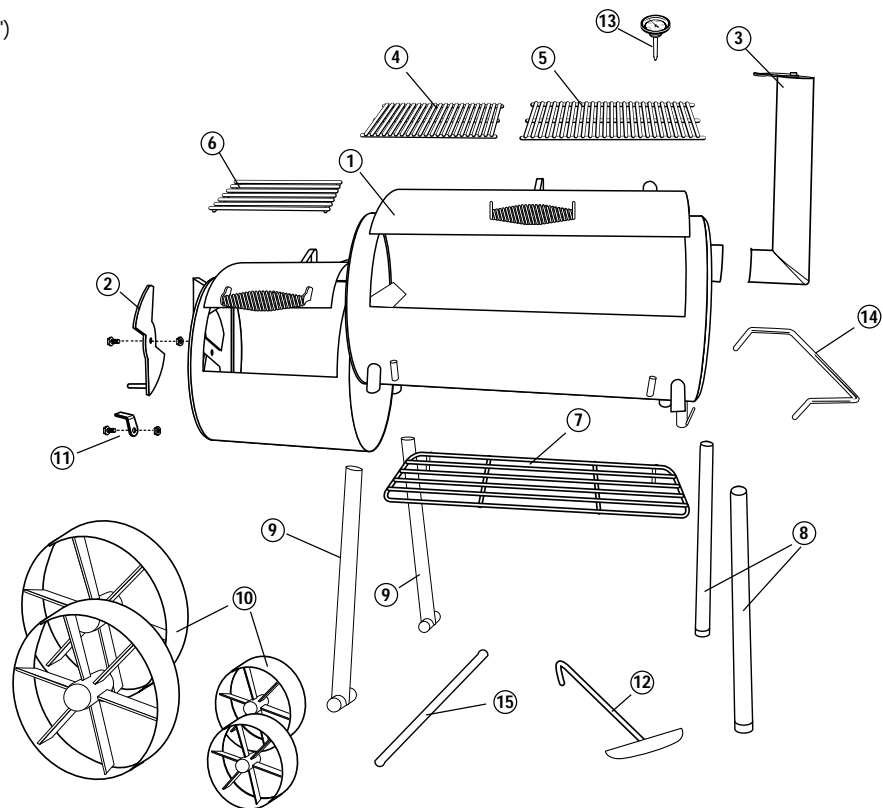

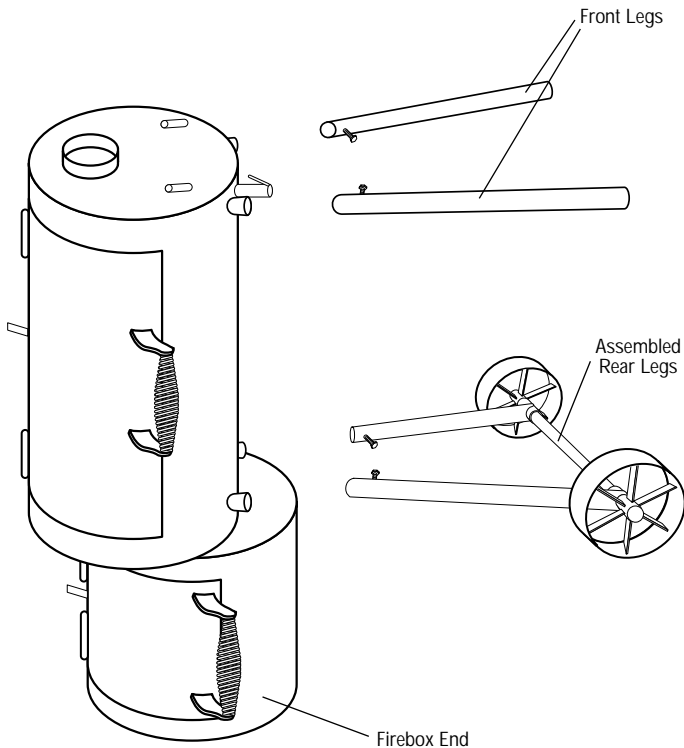
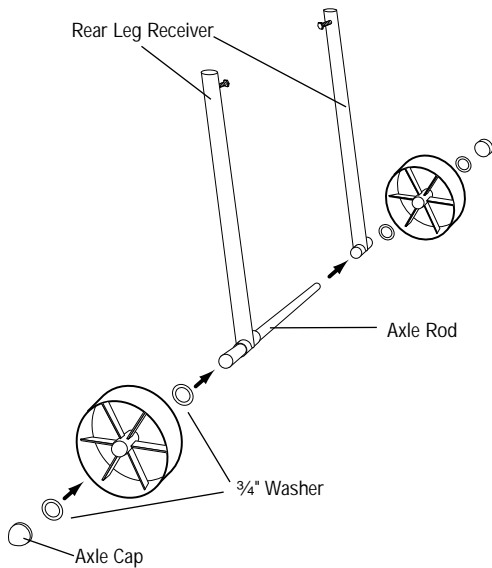

Clear an assembly area and get a friend to help you put your smoker together. Lay cardboard down to protect smoker finish and assembly area.

CAUTION: Remember, your new smoker weighs more than 250 lbs. so be extremely careful during the assembly process.

Step 1

With leg screws facing inward, insert axle rod through both rear leg receivers. Place a $\frac{3}{4}$ " washer on either side of a either $5\frac{1}{2}$ " or 16" wagon wheel and insert on one end of axle. Repeat on other side. Place axle caps on each end of axle and hammer into place.

Step 2

Place cooker on firebox end with the doors closed as illustrated. Make sure that another person is holding the cooker steady.

Step 3

Install assembled legs onto the leg receivers closest to firebox. Using a $\frac{9}{16}$ " wrench tighten screws securely.

Step 4

Install front legs onto leg receivers with screws facing in. Using a $\frac{9}{16}$ " wrench tighten screws securely.

Step 5

Keeping lids closed and with the help of an assistant, carefully turn the smoker to its upright position. Try to minimize the stress placed on the legs.

CAUTION: Keep lids closed when setting unit upright to prevent bodily injury.

NOTE: Your smoker has been built with a $\frac{1}{2}$ " tilt towards the smokestack end. To ensure proper grease drainage always keep your smoker on a level surface.

Step 6

Install smokestack inside smokestack pilot as illustrated. Tighten smokestack screw with $\frac{3}{16}$ " wrench.

Step 7

To install air vent damper, open the firebox door and attach damper to inside of firebox door as illustrated. Do not overtighten as this will make the air vent difficult to open and close.

NOTE: Make sure air vent damper handle faces outside of the firebox door.

Step 8

Attach the door latch to the outside of the firebox door as illustrated. Do not overtighten hex nut.

Step 9

Attach front shelf and side handle to smoker.

CAUTION: A metal bucket must be kept under grease hole at all times. Empty or replace bucket when $\frac{3}{4}$ full to prevent spills during removal. Use caution when removing to avoid spilling hot grease.

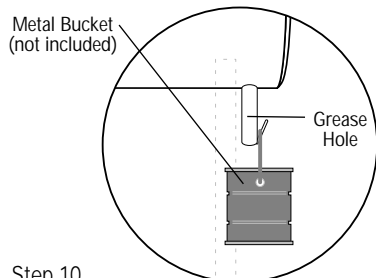

Step 10

Remove nut from temperature gauge hole in smoker. Remove tightening ring from gauge. Screw probe into temperature gauge hole in smoker. DO NOT OVERTIGHTEN!

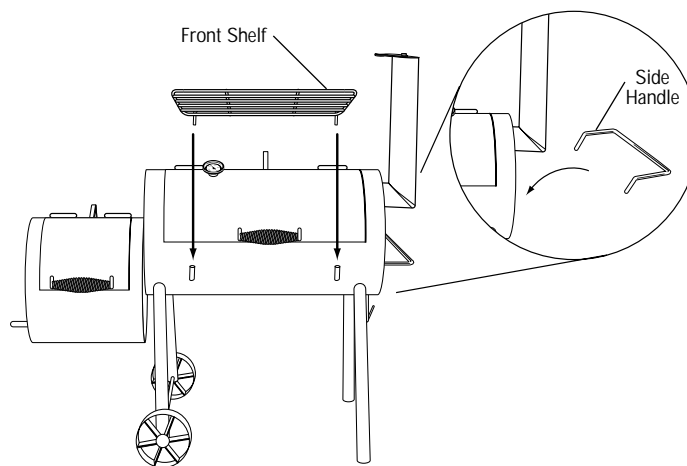
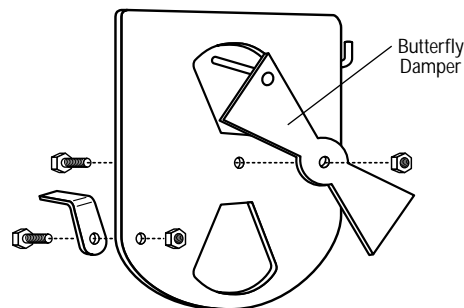
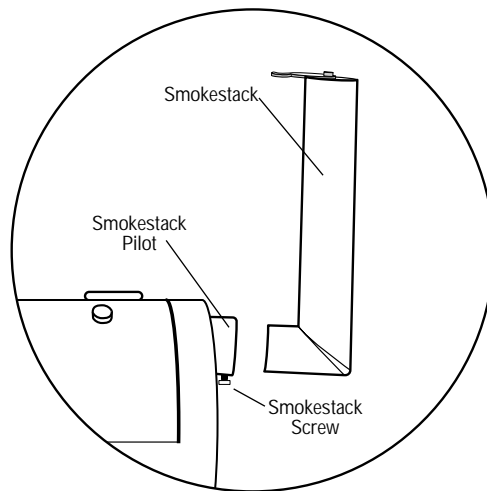
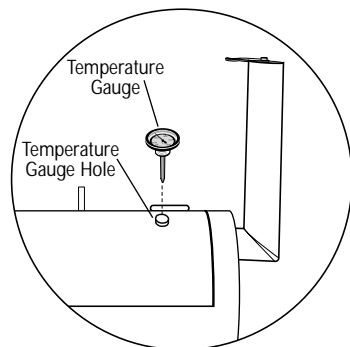

PREPARATION FOR USE & LIGHTING INSTRUCTIONS

⚠️ PLACE THE SMOKER OUTDOORS ON A HARD, LEVEL, NON-COMBUSTIBLE SURFACE AWAY FROM ROOF OVERHANG OR ANY COMBUSTIBLE MATERIAL. NEVER USE ON WOODEN OR OTHER SURFACES THAT COULD BURN. PLACE THE SMOKER AWAY FROM OPEN WINDOWS OR DOORS TO PREVENT SMOKE FROM ENTERING YOUR HOUSE. IN WINDY WEATHER, PLACE THE SMOKER IN AN OUTDOOR AREA THAT IS PROTECTED FROM THE WIND.

⚠️ READ ALL SAFETY WARNINGS AND INSTRUCTIONS CAREFULLY BEFORE OPERATING YOUR SMOKER.

Prior to your first use of the Brinkmann Cimarron, follow the instructions below carefully to cure smoker. Curing your smoker will minimize rust and damage to the exterior finish as well as rid smoker of paint odor that can impart unnatural flavors to the first meal prepared on your Cimarron.

Step 1

Lightly coat all interior surfaces of the smoker including cooking grills and charcoal grates with vegetable oil or vegetable oil spray.

Step 2

Place a charcoal grate in firebox. Place cooking grills in cooking chamber.

Step 3

Place a metal bucket on bracket under grease hole. A metal bucket must be placed under grease hole at all times.

Step 4

Follow the instructions below carefully to build a fire in the firebox. You may use charcoal and/or wood as fuel in the Cimarron (see "Adding Charcoal/Wood During Cooking" section of this manual).

If using a Charcoal Chimney Starter, follow all manufacturer's warnings and instructions regarding the use of their product. Start with 8 to 10 pounds of charcoal. This should be enough charcoal to cook with once the curing process has been completed. Open the firebox air vent approximately 1" to 2" and smokestack damper halfway. When charcoal is burning strong, carefully place the hot coals in center of firebox.

⚠️ WARNING: Keep hot coals away from the firebox air vent to prevent coals from falling out.

IF USING CHARCOAL CHIMNEY STARTER, PROCEED TO STEP 7.

If you choose to use charcoal lighting fluid, ONLY use charcoal lighting fluid approved for lighting charcoal. Do not use gasoline, kerosene, alcohol or other flammable material for lighting charcoal. Follow all manufacturer's warnings and instructions regarding the use of their product. Start with 8 to 10 pounds of charcoal. This should be enough charcoal to cook with, once the curing process has been completed. Place the charcoal in center of firebox.

⚠️ WARNING: Never use charcoal that has been pre-treated with lighter fluid. Use only a high grade plain charcoal or charcoal/wood mixture.

Curing Your Smoker

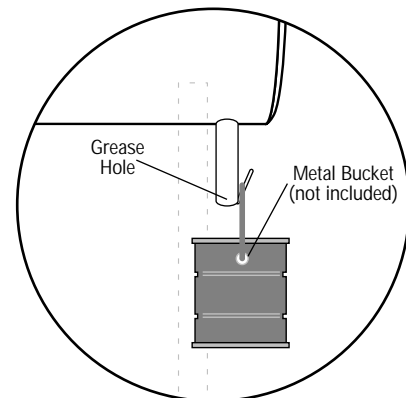
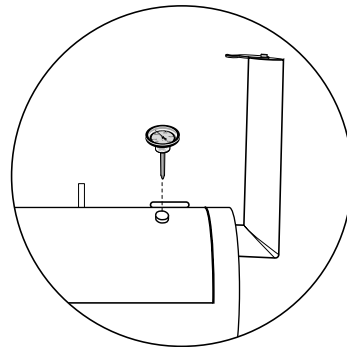

Step 5

Saturate charcoal with lighting fluid. With lid open, wait 2 to 3 minutes to allow lighting fluid to soak into charcoal. Store charcoal lighting fluid safely away from the smoker.

Step 6

Open the firebox air vent approximately 1" to 2" and smokestack damper half way. With firebox lid open, stand back and carefully light charcoal and allow to burn until covered with a light ash (approximately 20 minutes). Charcoal lighting fluid must be allowed to completely burn off prior to closing firebox lid.



WARNING: Failure to do this could trap fumes from charcoal lighting fluid in smoker and may result in a flash-fire or explosion when lid is opened.

Step 7

With coals burning strong in the firebox, close the lid. Use a temperature gauge to monitor temperature. A temperature of approximately 250°F in the cooking chamber is desired. Maintain this temperature for 1 to 2 hours.

Step 8

Increase the temperature to approximately 350°F to 400°F. This can be achieved by opening the firebox air vent and smokestack damper and adding more charcoal and/or wood (see "Adding Charcoal/Wood During Cooking" section of this manual). Maintain this temperature for 1 hour then allow unit to cool completely.

NOTE: Never exceed a temperature of 400°F in cooking chamber. It is important that the exterior of the smoker is not scraped or rubbed during the curing process.

IMPORTANT: Cure your smoker periodically throughout the year to protect against excessive rust.

**YOUR CIMARRON IS NOW CURED
AND READY FOR USE.**

OPERATING INSTRUCTIONS

⚠️ PLACE THE SMOKER OUTDOORS ON A HARD, LEVEL, NON-COMBUSTIBLE SURFACE AWAY FROM ROOF OVERHANG OR ANY COMBUSTIBLE MATERIAL. NEVER USE ON WOODEN OR OTHER SURFACES THAT COULD BURN. PLACE THE SMOKER AWAY FROM OPEN WINDOWS OR DOORS TO PREVENT SMOKE FROM ENTERING YOUR HOUSE. IN WINDY WEATHER, PLACE THE SMOKER IN AN OUTDOOR AREA THAT IS PROTECTED FROM THE WIND.

⚠️ READ ALL SAFETY WARNINGS AND INSTRUCTIONS CAREFULLY BEFORE OPERATING YOUR SMOKER.

⚠️ CAUTION: A metal bucket must be placed under the grease hole at all times to catch grease and/or ashes. Check grease level in bucket often and empty or change when $\frac{3}{4}$ full. Use extreme caution as bottom of cooking chamber, container and contents will be hot.

Step 1

Place a charcoal grate in firebox. Place cooking grills in cooking.

Step 2

Follow instructions below carefully to build a fire in the firebox. You may use charcoal and/or wood as fuel in the Cimarron (see "Adding Charcoal/Wood During Cooking" section of this manual).

If using a Charcoal Chimney Starter, follow all manufacturer's warnings and instructions regarding the use of their product. Open the firebox air vent approximately 1" to 2" and smokestack damper halfway. Carefully place 8 to 10 pounds of hot coals in center of charcoal grate in firebox.

⚠️ WARNING: Keep hot coals away from the firebox air vent to prevent coals from falling out.

IF USING CHARCOAL CHIMNEY STARTER, PROCEED TO STEP 5.

If you choose to use charcoal lighting fluid, ONLY use charcoal lighting fluid approved for lighting charcoal. Do not use gasoline, kerosene, alcohol or other flammable material for lighting charcoal. Follow all manufacturer's warnings and instructions regarding the use of their product. Place 8 to 10 pounds of charcoal in center of charcoal grate in firebox.

⚠️ WARNING: Never use charcoal that has been pre-treated with lighter fluid as a flash fire may occur. Use only a high grade plain charcoal or charcoal/wood mixture.

Step 3

Saturate charcoal with lighting fluid. With lid open, wait 2 to 3 minutes to allow lighting fluid to soak into charcoal. Store charcoal lighting fluid safely away from the smoker.

Step 4

Open the firebox air vent approximately 1" to 2" and smokestack damper half way. With firebox lid open, stand back and carefully light charcoal and allow to burn until covered with a light ash (approximately 20 minutes). Charcoal lighting fluid must be allowed to completely burn off prior to closing firebox lid.

⚠️ WARNING: Failure to do this could trap fumes from charcoal lighting fluid in smoker and may result in a flash-fire or explosion when lid is opened.

Smoking

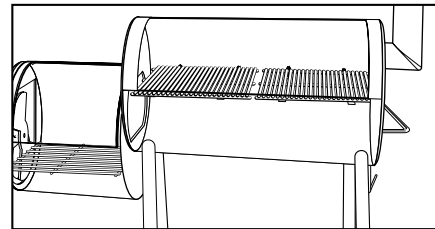

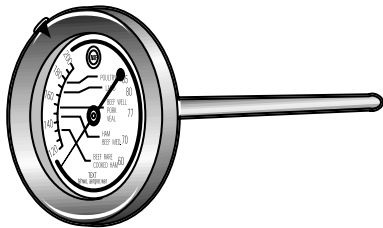

Grilling In Cooking Chamber

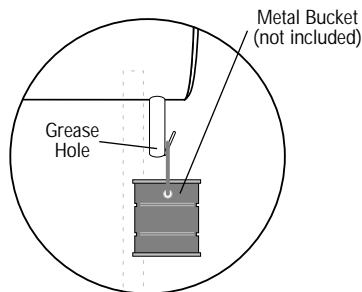

Step 5

With coals burning well, carefully add wood chunks using long cooking tongs (see "Flavoring Wood" and "Adding Charcoal/Wood During Cooking" sections of this manual.)

Step 6

Place food on cooking grills in the cooking chamber.

Step 7

Close firebox and cooking chamber lids. Adjust the firebox air vent and smokestack damper to regulate cooking temperature.

NOTE: Do not fully close air vent, damper and lids unless trying to cool the smoker down or suffocate a flame.

Step 8

By closing the air vent and smokestack damper more, the burning intensity is slowed and smoke is contained within the cooking chamber, imparting more smoke flavor to food. The ideal smoking temperature is between 175°F and 250°F.

Step 9

For large cuts of meat, allow approximately one hour of cooking time per pound of meat. **Always use a meat thermometer to ensure food is fully cooked before removing from smoker.**

A meat thermometer may be ordered directly from Brinkmann by calling 1-800-468-5252.

Step 10

Allow smoker to cool completely, then follow instructions in the "After-Use Safety" and "Proper Care & Maintenance" sections of this manual.

WARNING: A metal bucket must be placed under the grease hole at all times to catch grease and/or ashes. Check grease level in bucket often. Empty or change grease bucket when $\frac{3}{4}$ full. Use extreme caution as bottom of cooking chamber, container and contents will be hot.

Step 1

Remove cooking grills from cooking chamber and set aside. Place charcoal grate in bottom of cooking chamber.

Step 2

Follow instructions below carefully to build a fire in the cooking chamber. You may use charcoal and/or wood as fuel in the Cimarron (see "Adding Charcoal/Wood During Cooking" section of this manual).

If using a Charcoal Chimney Starter, follow all manufacturer's warnings and instructions regarding the use of their product. Open the firebox air vent approximately 1" to 2" and smokestack damper halfway. Carefully place 8 to 10 pounds of hot coals in center of charcoal grates in cooking chamber. Using long cooking tongs, carefully spread briquets evenly on the charcoal grates, one to two layers thick.

IF USING CHARCOAL CHIMNEY STARTER, PROCEED TO STEP 5.

If you choose to use charcoal lighting fluid, **ONLY** use charcoal lighting fluid approved for lighting charcoal. Do not use gasoline, kerosene, alcohol or other flammable material for lighting charcoal. Follow all manufacturer's warnings and instructions regarding the use of their product. Place 8 to 10 pounds of charcoal in center of charcoal grate in cooking chamber.

⚠ WARNING: Never use charcoal that has been pre-treated with lighter fluid as a flash fire may occur. Use only a high grade plain charcoal or charcoal/wood mixture.

Step 3

Saturate charcoal with lighting fluid. With lid open, wait 2 to 3 minutes to allow lighting fluid to soak into charcoal. Store charcoal lighting fluid safely away from the grill.

Step 4

Fully open the firebox air vent and smokestack damper. Stand back and carefully light charcoal. With firebox and cooking chamber lids open, allow charcoal to burn until covered with a light ash (approximately 20 minutes). Charcoal lighting fluid must be allowed to completely burn off prior to closing firebox and cooking chamber lid.

⚠ WARNING: Failure to do this could trap fumes from charcoal lighting fluid in grill and may result in a flash-fire or explosion when lids are opened.

Step 5

When charcoal is burning well, use long cooking tongs to carefully spread briquets evenly on the charcoal grates, one to two layers thick. If desired, add wood chunks using long cooking tongs (see "Flavoring Wood" and "Adding Charcoal/Wood During Cooking" sections of this manual.)

Step 6

Wearing oven mitts/gloves, place the cooking grills in cooking chamber. Place food on cooking grills.

Step 7

Close firebox and cooking chamber lids. Adjust the firebox air vent and smokestack damper to regulate cooking temperature.

NOTE: Do not fully close air vent, damper and lids unless trying to cool the smoker down or suffocate a flame.

Step 8

By closing the air vent and smokestack damper more, the burning intensity is slowed and smoke is contained within the cooking chamber, imparting more smoke flavor to food. **Always use a meat thermometer to ensure food is fully cooked before removing from smoker.**

Step 9

Allow smoker to cool completely, then follow instructions in the "After-Use Safety" and "Proper Care & Maintenance" sections of this manual.

Placement of Charcoal Grate

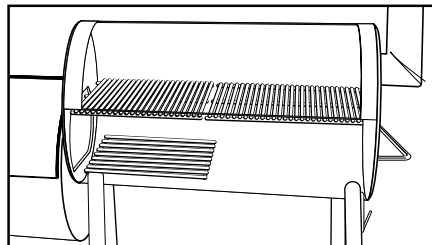

Smoke Cooking Tips

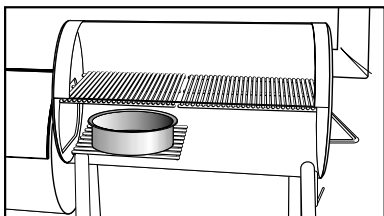

*Water pan sold separately.

- During the smoking process, avoid the temptation to open lid to check food. Opening the lid allows heat and smoke to escape, making additional cooking time necessary.
- Food closest to the firebox will cook and brown faster. Rotate food midway through the cooking cycle. If food is excessively browned or flavored with smoke, wrap food in aluminum foil after the first few hours of smoking. This will allow food to continue cooking without further browning or smoke flavoring.
- When cooking fish or extra lean cuts of meat, you may want to try water smoking to keep the food moist. Before starting a fire in firebox, place charcoal grate in cooking chamber. Use a flat bottom metal pan that is shallow enough to fit between the charcoal grate and cooking grill as a water pan. Set the metal pan on charcoal grate under food and cooking grill and fill with water or marinade until $\frac{2}{3}$ full.

CAUTION: Always use oven mitts/gloves to protect your hands. Liquid in water pan will be extremely hot and can scald or burn. Always allow liquid to cool completely before handling. Do not allow liquid to completely evaporate from water pan.

- **Always use a meat thermometer to ensure food is fully cooked before removing from smoker.** A meat thermometer may be ordered directly from Brinkmann by calling 1-800-468-5252.

Flavoring Wood

To obtain your favorite smoke flavor, experiment by using chunks, sticks or chips of flavor producing wood such as hickory, pecan, apple, cherry, or mesquite. Most fruit or nut tree wood may be used for smoke flavoring. Do not use resinous wood such as pine as it will produce an unpleasant taste.

Sticks of wood 8" to 12" long and 2" to 3" thick work best. A lot of wood is not required to obtain a good smoke flavor. A recommended amount for the Cimarron is 5 to 6 sticks of wood. Experiment by using more wood for stronger smoke flavor or less wood for milder smoke flavor.

Additional flavoring wood should not have to be added during the cooking process. However, it may be necessary when cooking very large pieces of food. Follow instructions and cautions in the "Adding Charcoal/Wood During Cooking" section of this manual to avoid injury while adding wood.

Regulating Heat

To increase heat and air circulation, fully open firebox air vent and smokestack damper. If increased air circulation does not raise temperature sufficiently, more wood and/or charcoal may be needed. Follow instructions in "Adding Charcoal/Wood During Cooking" section of this manual.

To maintain the temperature, more wood and/or charcoal may need to be added during the cooking cycle.

NOTE: Dry wood burns hotter than charcoal, so you may want to increase the ratio of wood to charcoal to increase the cooking temperature. Hardwood such as oak, hickory, mesquite, fruit and nut wood are an excellent fuel because of their burning rate. When using wood as fuel, make sure the wood is seasoned and dry. **DO NOT** use resinous wood such as pine as it will produce an unpleasant taste.

Additional charcoal and/or wood may be required to maintain or increase cooking temperature.

Adding Charcoal/Wood in Firebox

Step 1

Stand back and carefully open firebox lid. Use caution since flames can flare-up when fresh air suddenly comes in contact with fire.

Step 2

Wearing oven mitts/gloves, stand back a safe distance and use long cooking tongs to lightly brush aside ashes on hot coals. Use cooking tongs to add charcoal and/or wood, being careful not to stir-up ashes and sparks. If necessary, use your Charcoal Chimney Starter to light additional charcoal and/or wood and add to existing fire.

⚠ WARNING: Never add charcoal lighting fluid to hot or even warm coals as flashback may occur causing severe burns.

Step 3

When charcoal is burning strong again, close the firebox lid.

Adding Charcoal/Wood in Cooking Chamber

Step 1

Stand back and carefully open cooking chamber lid. Use caution since flames can flare-up when fresh air suddenly comes in contact with fire.

Step 2

Wearing oven mitts/gloves, remove food and cooking grills.

Step 3

Stand back a safe distance and use long cooking tongs to lightly brush aside ashes on hot coals. Use cooking tongs to add charcoal and/or wood, being careful not to stir-up ashes and sparks. If necessary, use your Charcoal Chimney Starter to light additional charcoal and/or wood and add to existing fire.

⚠ WARNING: Never add charcoal lighting fluid to hot or even warm coals as flashback may occur causing severe burns.

Step 4

When charcoal is burning strong again, wear oven mitts/gloves and carefully replace cooking grills and food.

Step 5

Close the cooking chamber lid and allow food to continue cooking.

Adding Charcoal/Wood During Cooking



AFTER-USE SAFETY

WARNING

- Always allow smoker and all components to cool completely before handling.
- Never leave coals and ashes in smoker unattended. Make sure coals and ashes are completely extinguished before removing.
- Before smoker can be left unattended, remaining coals and ashes must be removed from smoker. Use caution to protect yourself and property. Place remaining coals and ashes in a noncombustible metal container and completely saturate with water. Allow coals and water to remain in metal container 24 hours prior to disposing.
- Extinguished coals and ashes should be placed a safe distance from all structures and combustible materials.
- With a garden hose, completely wet surface beneath and around the smoker to extinguish any ashes, coals or embers which may have fallen during the cooking or cleaning process.
- Allow metal bucket and its contents to cool completely before removing. Dispose of contents properly.
- Cover and store smoker in a protected area away from children and pets.

Proper Care & Maintenance

- Cure your smoker periodically throughout the year to protect against excessive rust.
- Wash cooking grills and charcoal grate with hot, soapy water, rinse well and dry. Lightly coat grills and grate with vegetable oil or vegetable oil spray.
- Clean inside and outside of smoker by wiping off with a damp cloth. Apply a light coat of vegetable oil or vegetable oil spray to the interior surface to prevent rusting.
- If rust appears on the exterior surface of your smoker, clean and buff the affected area with steel wool or fine grit emery cloth. Touch-up with a good quality high-temperature resistant paint.
- Never apply paint to the interior surface. Rust spots on the interior surface can be buffed, cleaned, then lightly coated with vegetable oil or vegetable oil spray to minimize rusting.
- A quality smoker cover will minimize rusting and can be ordered from Brinkmann at **1-800-468-5252**.

ACCESSORIES

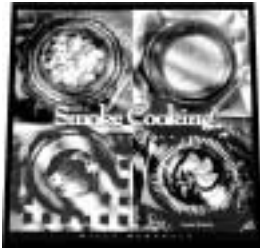

The Art of Smoke Cooking Cookbook
Contains 40 exciting yet simple recipes using the delicious technique of smoke cooking. Beautifully photographed full-color, sixty-six page hardback cookbook presents old favorites as well as new recipes such as smoked meatballs & spaghetti, smoked pizza, smoked tomato soup and smoked peach cobbler.
Model 812-3327-0

Rib Rack

Chrome-plated rack can greatly increase the cooking capacity of your smoker. Holds ribs, chicken halves, potatoes and corn vertically to triple cooking capacity. Allows smoke, steam and heat to penetrate food evenly.
Model 600-0062-3

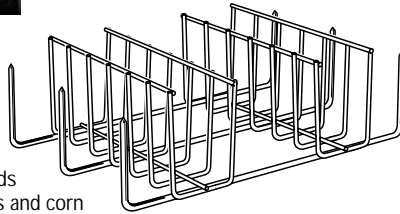

Smoker Basket

The unique basket weave prevents food from falling through the grill while allowing smoke, steam and heat to flow into the food. Great for fish, shrimp, vegetables and hors d'oeuvres. Also, provides a convenient method for lifting food in and out of the smoker. Great for large cuts of meat such as turkeys and roasts.
Model 400-0074-0

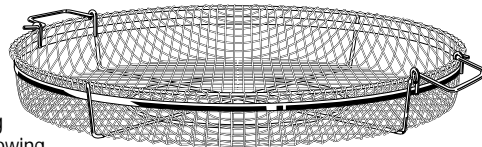

Meatloaf Basket

The unique basket weave prevents meatloaf from falling through the grill while allowing smoke, steam and heat to flow into the food. Also, provides a convenient method for lifting your meatloaf in and out of the smoker.
Model 400-0073-0

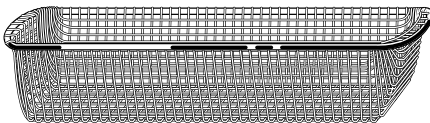

Deluxe Charcoal Starter

The Brinkmann Deluxe Charcoal Starter is the fastest and healthiest way to light charcoal without using lighter fluid. Just place crumpled newspaper under the charcoal starter, fill with charcoal and light. You'll have hot, glowing coals in about 15 minutes with no unpleasant fumes to affect the flavor of your food. Our unique design allows you to pour the hot coals from the top or simply slide the grate out and lift to release hot coals through the bottom of starter into your smoker or grill.
Model 812-4080-0

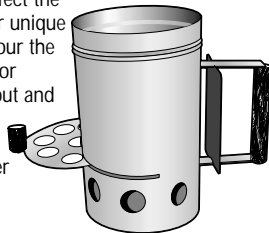

Smoke'N Spice Seasoning

These custom blended spices are a delicious marinade seasoning for smoke cooking and grilling. Contains no MSG. Available in red and white meat varieties in a money-saving 2-pack.
Model 812-3322-0



Metal Grease Bucket

This metal bucket conveniently hangs from the L-bracket on your Cimarron, Professional or Pitmaster horizontal smoker to catch falling grease and ash. Made of aluminum.
Model 812-3105-0

Commercial-Quality Meat Thermometer

An essential tool when cooking all types of meat. Get perfectly smoked roasts, briskets and turkeys without cutting into the meat. Commercial-quality thermostat features an easy-to-read 2 3/4" dial with a 5 1/2" stem. Features Fahrenheit and Centigrade readings and National Livestock and Meat Board recommended temperatures. Also features the newly recommended 170°F internal temperature for fresh pork. Stainless steel construction and dishwasher safe.
Model 812-4100-0

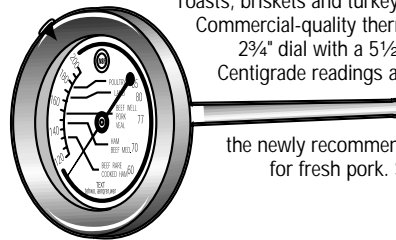

LOOK FOR THESE AND OTHER BRINKMANN ACCESSORIES AT YOUR LOCAL RETAILER WHERE SMOKERS ARE SOLD, OR ORDER DIRECT BY CALLING 1-800-468-5252.

ACCESSORIES

Cimarron Cooking Grill

Heavy-duty steel 15 1/4" x 12 1/16" cooking grill. For use with Cimarron and Cimarron Limited Smoker & Grills.

Model 115-1215-0

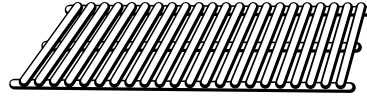
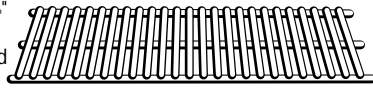

Cimarron Cooking Grill

Heavy-duty steel 15 1/4" x 15" cooking grill. For use with Cimarron and Cimarron Limited Smoker & Grills.

Model 115-1515-0

Smoke'N Pit Horizontal Charcoal Grate

Heavy-duty steel grate 9" x 14 allows airflow around charcoal. For use with Cimarron and Cimarron Limited Smoker & Grills.

Model 115-0914-0

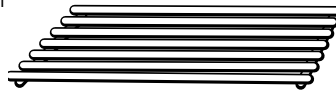

75 YEAR LIMITED WARRANTY

For 75 years from date of purchase, The Brinkmann Corporation warrants the Cimarron or Cimarron Limited against defects due to workmanship or materials to the original purchaser. The Brinkmann Corporation's obligations under this warranty are limited to the following guidelines:

- This warranty does not cover smokers that have been altered or damaged due to: normal wear, rust, abuse, improper maintenance, improper use, disassembly of parts and/or attempted repair by anyone other than an authorized employee of The Brinkmann Corporation.
- This warranty does not cover surface scratches or heat damage to the finish, which is considered normal wear.
- The Brinkmann Corporation may elect to repair or replace damaged parts covered by the terms of this warranty.
- This warranty extends to the original purchaser only and is not transferable or assignable to subsequent purchasers.

The Brinkmann Corporation requires reasonable proof of purchase. Therefore, we strongly recommend that you retain your sales receipt or invoice. To obtain replacement parts for your Cimarron or Cimarron Limited under the terms of this warranty, please call Customer Service Department at 800-527-0717. **A receipt will be required.** The Brinkmann Corporation will not be responsible for any cookers forwarded to us without authorization. Cimarron or Cimarron Limited must be returned to the original place of purchase for replacement of the unit.

EXCEPT AS ABOVE STATED, THE BRINKMANN CORPORATION MAKES NO OTHER EXPRESS WARRANTY.

THE IMPLIED WARRANTIES OF MERCHANTABILITY AND FITNESS FOR A PARTICULAR PURPOSE ARE LIMITED IN DURATION TO 75 YEARS FROM THE DATE OF PURCHASE. SOME STATES DO NOT ALLOW LIMITATIONS ON HOW LONG AN IMPLIED WARRANTY LASTS, SO THE ABOVE LIMITATION MAY NOT APPLY TO YOU.

ANY LIABILITY FOR INDIRECT, INCIDENTAL OR CONSEQUENTIAL DAMAGES ARISING FROM THE FAILURE OF THE CIMARRON OR CIMARRON LIMITED TO COMPLY WITH THIS WARRANTY OR ANY IMPLIED WARRANTY IS EXCLUDED. CUSTOMER ACKNOWLEDGES THAT THE PURCHASE PRICE CHARGED IS BASED UPON THE LIMITATIONS CONTAINED IN THE WARRANTY SET OUT ABOVE. SOME STATES DO NOT ALLOW THE EXCLUSION OR LIMITATION OF INCIDENTAL OR CONSEQUENTIAL DAMAGES, SO THE ABOVE LIMITATION OR EXCLUSION MAY NOT APPLY TO YOU. THIS WARRANTY GIVES YOU SPECIFIC LEGAL RIGHTS, AND YOU MAY ALSO HAVE OTHER RIGHTS WHICH VARY FROM STATE TO STATE.

Free Manuals Download Website

<http://myh66.com>

<http://usermanuals.us>

<http://www.somanuals.com>

<http://www.4manuals.cc>

<http://www.manual-lib.com>

<http://www.404manual.com>

<http://www.luxmanual.com>

<http://aubethermostatmanual.com>

Golf course search by state

<http://golfingnear.com>

Email search by domain

<http://emailbydomain.com>

Auto manuals search

<http://auto.somanuals.com>

TV manuals search

<http://tv.somanuals.com>