

Installation Instructions

MG-2/TT

Express® Lavatory System - MG-Series with TouchTime® Control



Table of Contents

Pre-Installation Information	2
Dimensions	3-4
Installation Instructions	5-12
Cleaning and Maintenance	13
Assembly of Components	14-16
Solenoid Valve Troubleshooting	17-18
Vernatherm™ Valve Maintenance	19-20
Cleaning the Strainer	19-20



IMPORTANT

Read this entire installation manual to ensure proper installation.

Flush all the water supply lines before making connections.

Wall anchors used must have a minimum pull-out rating of 1,000 lbs.

File these instructions with the owner or maintenance department.

Product warranties may be found under "Product Information" on our web site at www.bradleycorp.com.



Pre-Installation Information

Barrier-free and ADA compliant - standard height mounting

The MG-2/TT Express® Lavatory System must have a rim height no higher than 34" above finished floor to be compliant with Americans with Disabilities Act (ADA). When mounted at 34" rim height, the MG-2/TT Express® Lavatory System meets ADA, ANSI and UFAS requirements for barrier-free clearances, reaches and controls. Always check local codes and ordinances for compliance.

Barrier-free and ADA compliant - juvenile height mounting

The MG-2/TT Express® Lavatory System must have a rim height no higher than 30" above finished floor to be compliant with Americans with Disabilities Act (ADA) Accessibility Guidelines for Buildings and Facilities: Building Elements Designed for Children's Use; Final Rule.

Texas Accessibility Standards compliant:

The MG-2/TT Express® Lavatory System meets Texas Accessibility standards (TAS) for barrier-free clearances, reaches and controls. Always check local codes and ordinances for compliance.

TouchTime® switch and solenoid

Each sprayhead is controlled by a TouchTime® switch, enabling each user to activate a single flow of water. Each valve uses less than half the maximum of hot water allowed by the ANSI/ASHRAE/IESNA 90.1-1989 Standard.

Supplies required for installation:

- (8) 3/8" wall anchors, bolts and washers to mount frame and bowl to wall (minimum pull-out rating of 1,000 lbs.)
- 1/2" NPT hot and cold supply piping and 1-1/2" NPT drain piping
- 1/2" NPT street elbow
- 110 volt electrical outlet for 110/24 VAC plug-in transformer (supplied)
- 240/208-volt or 277-volt electrical outlet for optional electric tankless water heater

MG-2/TT Express® Lavatory System Dimensions

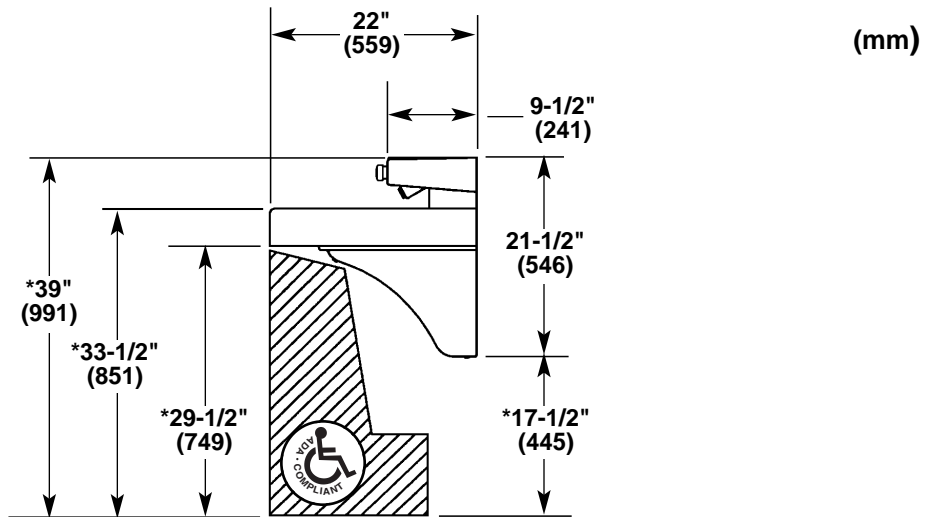
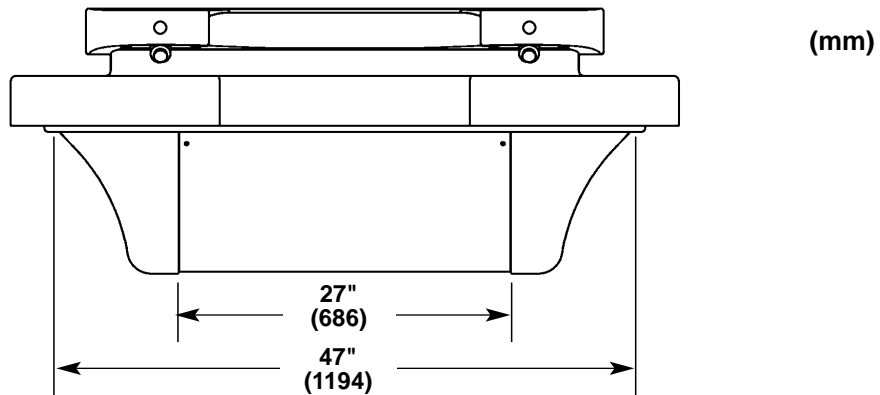
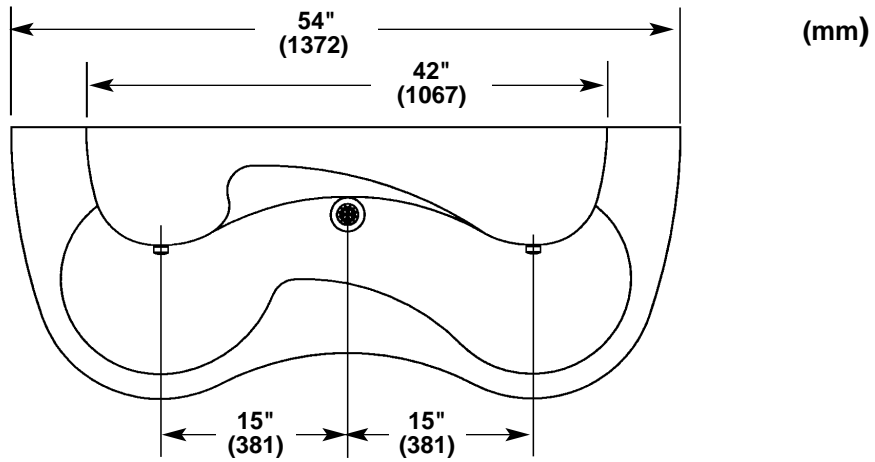

*Subtract 4" from vertical dimensions for compliance with ADA guidelines for children's use.

Dimensions *continued* . . .

TAS Juvenile Height
Grades Pre-K thru 5 or 6

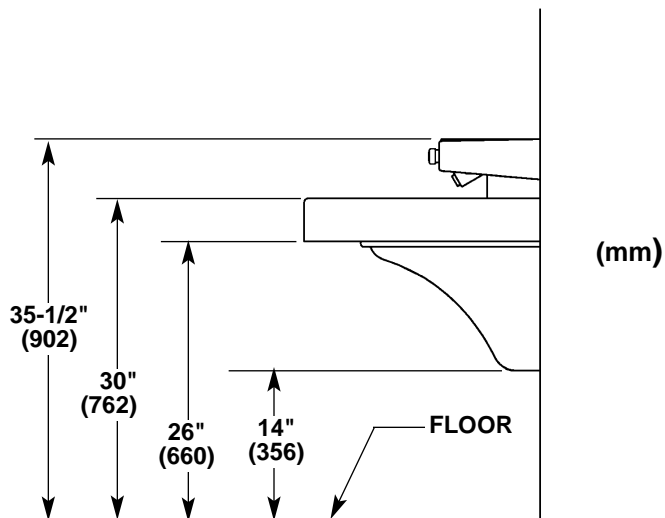

TAS Juvenile Height
Grades 6 thru 8 or 9

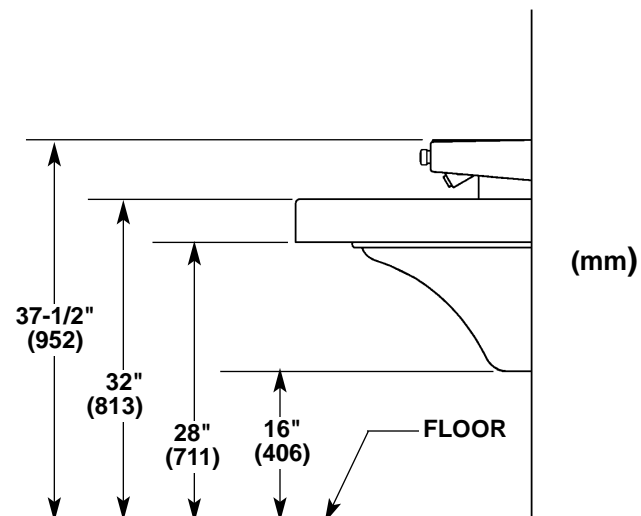

Installation Instructions

Step 1: Rough in supplies and optional hot water heater

NOTE: See Figure 1 (below), 1a, 1b (for TAS on page 6) and Figure 2 (on page 7) when roughing in the MG-2/TT Express®.

- ⚠ IMPORTANT:** Flush the supply lines before making connections. Debris in supply lines will cause the valves to malfunction.
- ⚠ IMPORTANT:** Dimensions shown in Figure 1 are for Standard Height Mounted MG-2/TT Express®.

1. Rough in 1/2" NPT hot and cold supply lines through wall at dimensions shown.
2. Rough in 1-1/2" NPT drain waste connection through wall at dimensions shown.
3. OPTIONAL HOT WATER HEATER: Rough in appropriate electrical supply per local code (recommended 240/208-volt or 277-volt electrical box location shown below).

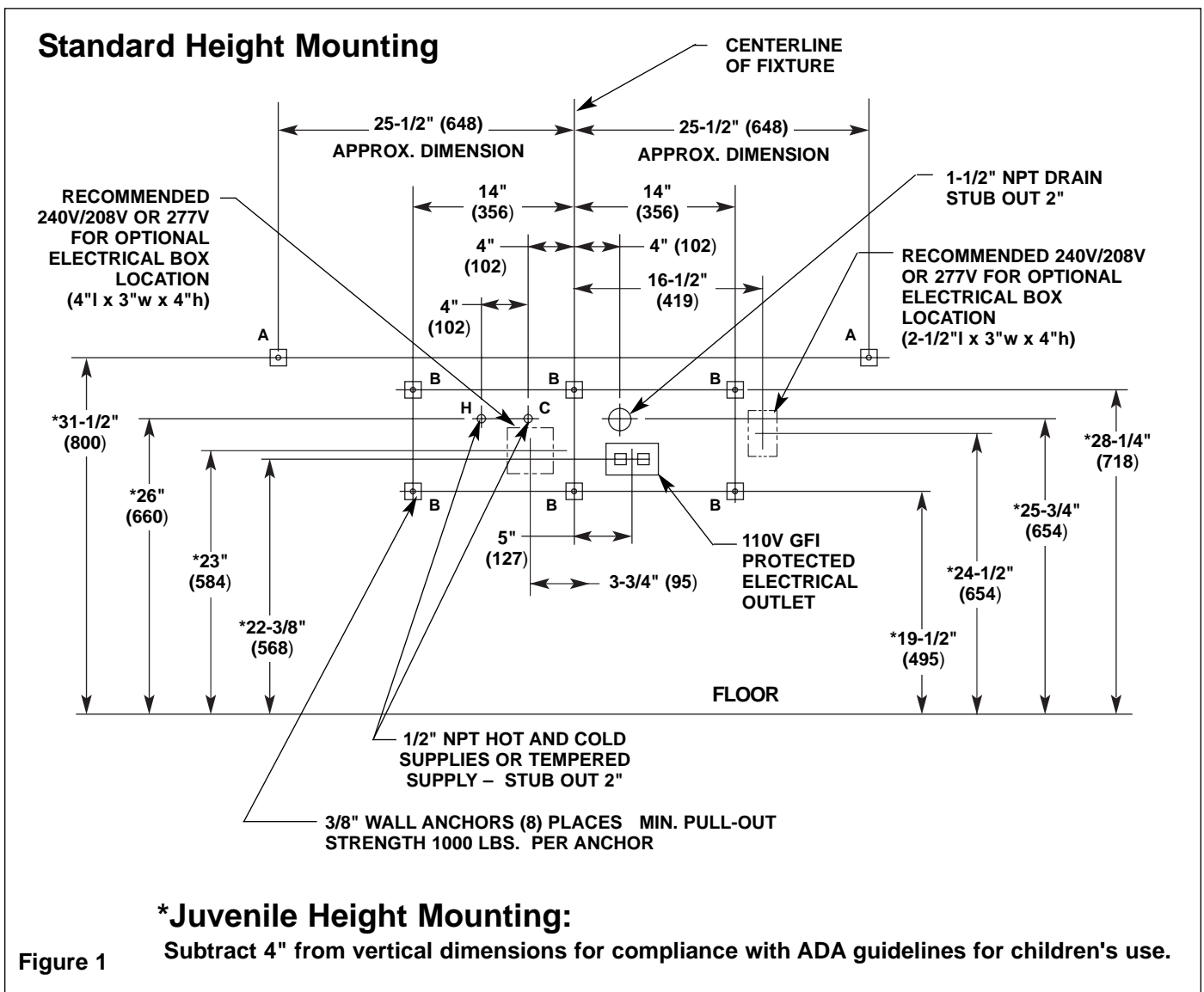

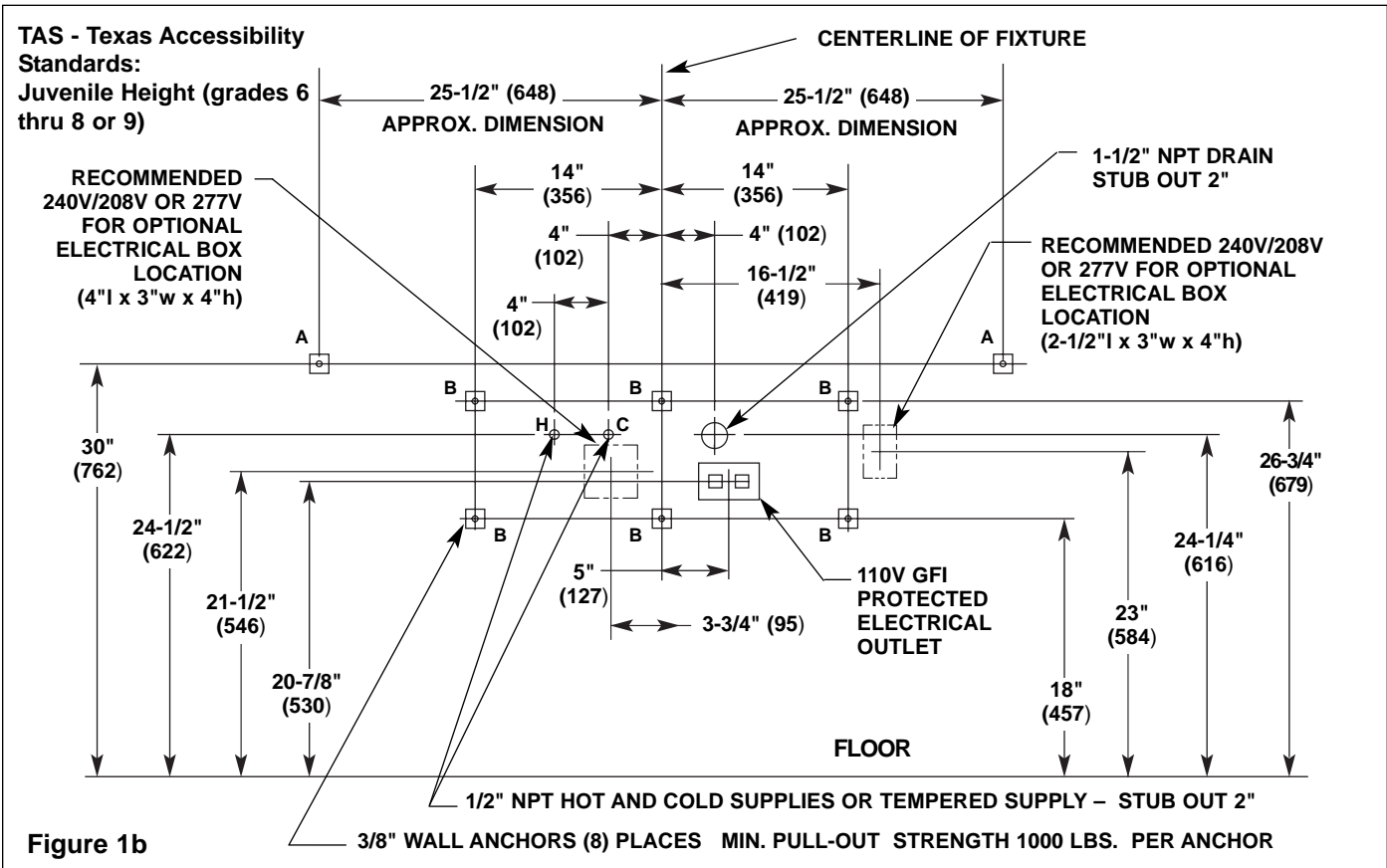
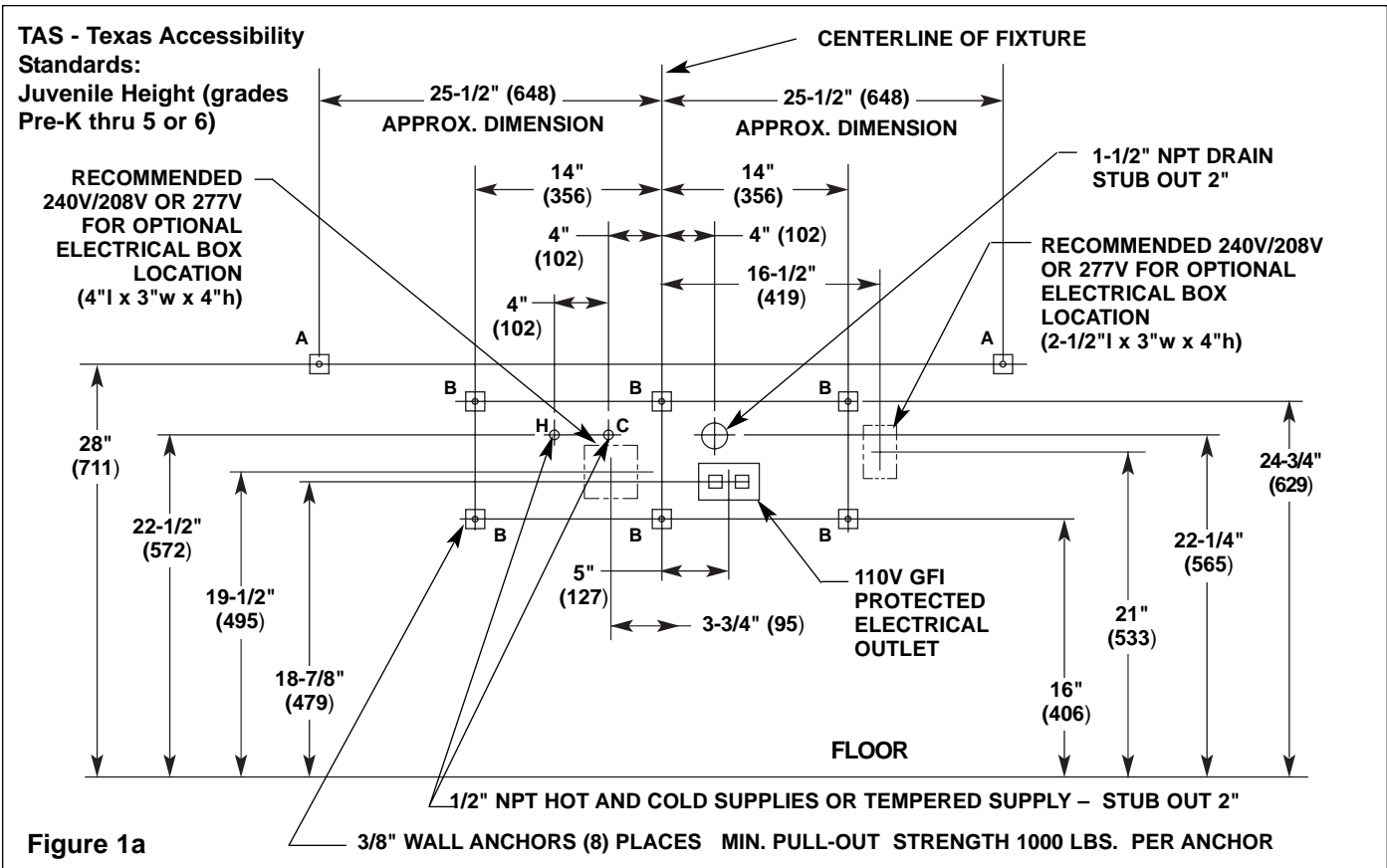

Installation Instructions *continued* . . .

Step 2: Rough in wall anchors and electrical outlet

⚠ IMPORTANT: Turn OFF electrical power to the outlet when installing the Express® Lavatory System.

1. Install a 110 volt GFI protected electrical outlet per local code at the location shown in Figure 2.
2. Install six 3/8" wall anchors with a minimum pull-out rating of 1,000 lbs. (supplied by installer) at the locations marked (ref. location "B" shown in Figure 1, 1a or 1b on pages 5-6).

NOTE: The dimensions for the wall anchors at location "A" are for reference only.

3. On the back of the bowl, measure the distance between the 3/4" bowl mounting holes. Divide this measurement in half. Measure and mark this dimension on the wall to the left of the centerline and to the right of the centerline. Install two 3/8" wall anchors with a minimum pull-out rating of 1,000 lbs. (supplied by installer) at the locations marked (ref. location "A" shown in Figure 1, 1a or 1b on pages 5-6).

NOTE: The anchors will be used to mount the Express® MG-2/IR bowl and frame to the wall.

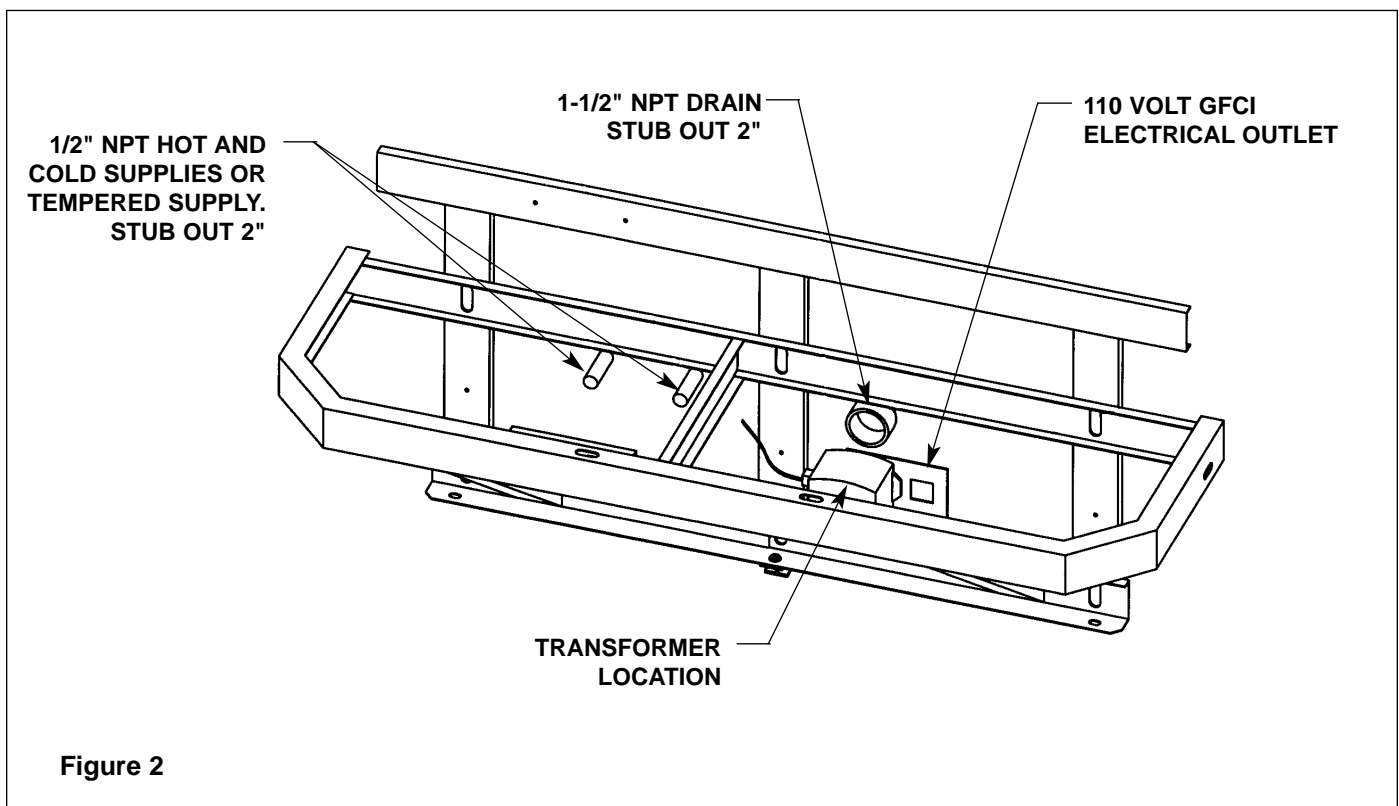

Installation Instructions *continued* . . .

Step 3: Mount frame to wall

1. Loosen, but do not remove the three bottom access panel screws.
2. Remove the two top access panel screws and washers securing the access panel to the frame and remove the access panel (see Figure 3).
3. Position the frame with Terreon® End Caps attached, against the wall, ensuring that it is level.



IMPORTANT: Anchoring the frame to a wall that is *not* flat may cause the frame to bend. If necessary, install shims to compensate for wall distortion.

4. Ensure that the back of the frame is flat against the wall. If wall is not flat, insert shims behind the frame to ensure that it will not bend when anchored.
5. Once you have positioned the frame such that it is level and flat against the wall or shimmed, use the 3/8" bolts and washers to mount the frame to the wall.

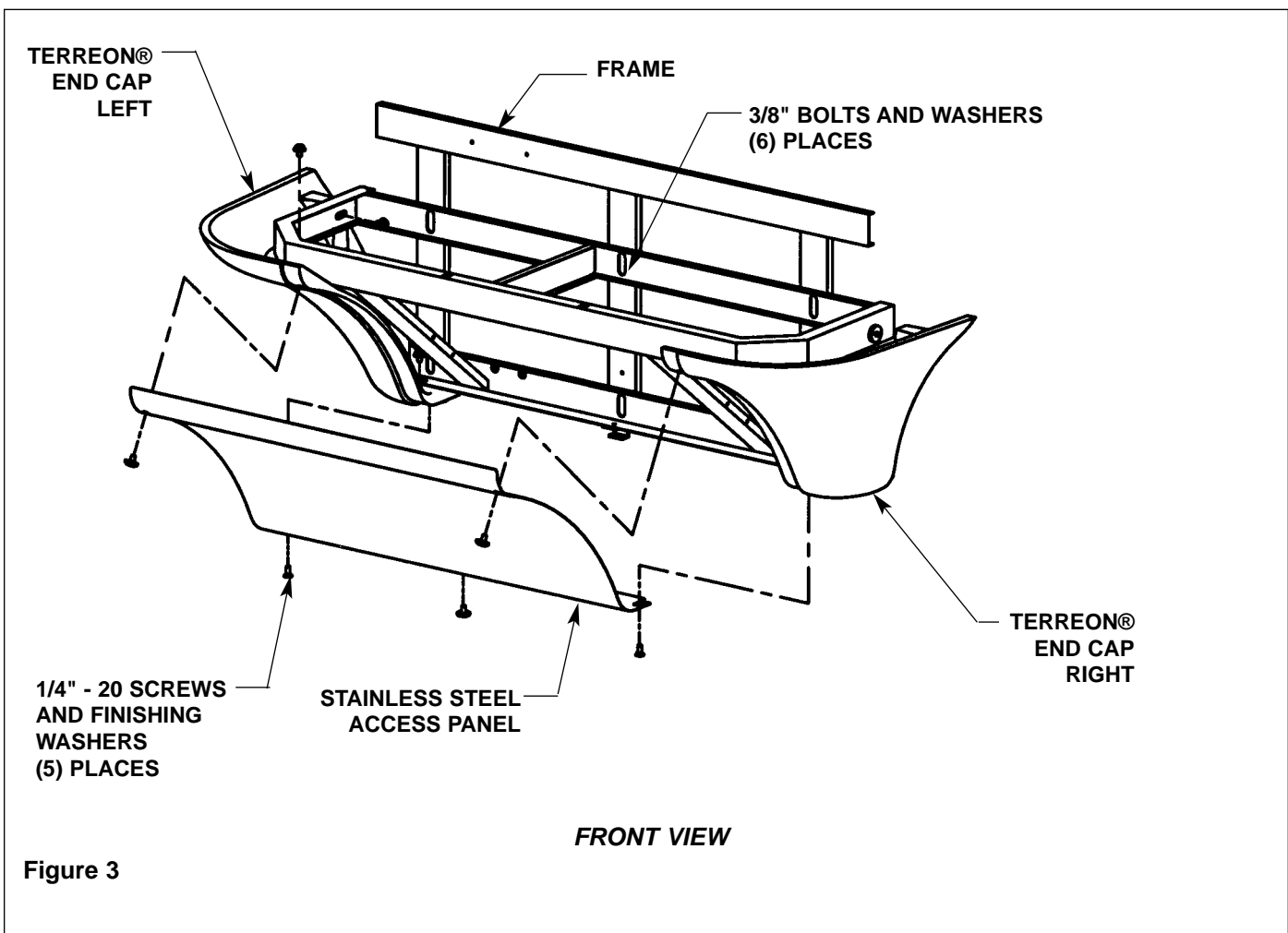

Installation Instructions *continued . . .*

Step 4: Install bowl assembly

⚠ IMPORTANT: See Figure 4 below when installing the bowl assembly. If the fixture has soap option, refer to the soap installation manual 215-1585 before installing the bowl assembly.

1. With someone to assist you, place the bowl assembly squarely onto the frame being careful not to pinch tubing between bowl and frame.
2. Attach the front of the bowl assembly to the frame using the two 1/4-20 x 1/2" pan-head screws and washers provided. **Do not tighten screws at this time.**

⚠ IMPORTANT: When bolting the bowl assembly to the wall, do not overtighten the bolts. Overtightening bolts can damage the Terreon® material.

3. After the bowl assembly is attached to the frame, install the two 3/8" bolts and washers (supplied by the installer) to bolt the bowl to the wall anchors. **Do not overtighten bolts.**
4. Tighten the screws installed in procedure #2 above to secure the bowl assembly to the frame. **Do not overtighten.**
5. If necessary, adjust sprayhead body to fit closely to wall by adjusting sprayhead mounting bolts. See Figure 8 on page 14 for sprayhead mounting bolt locations.

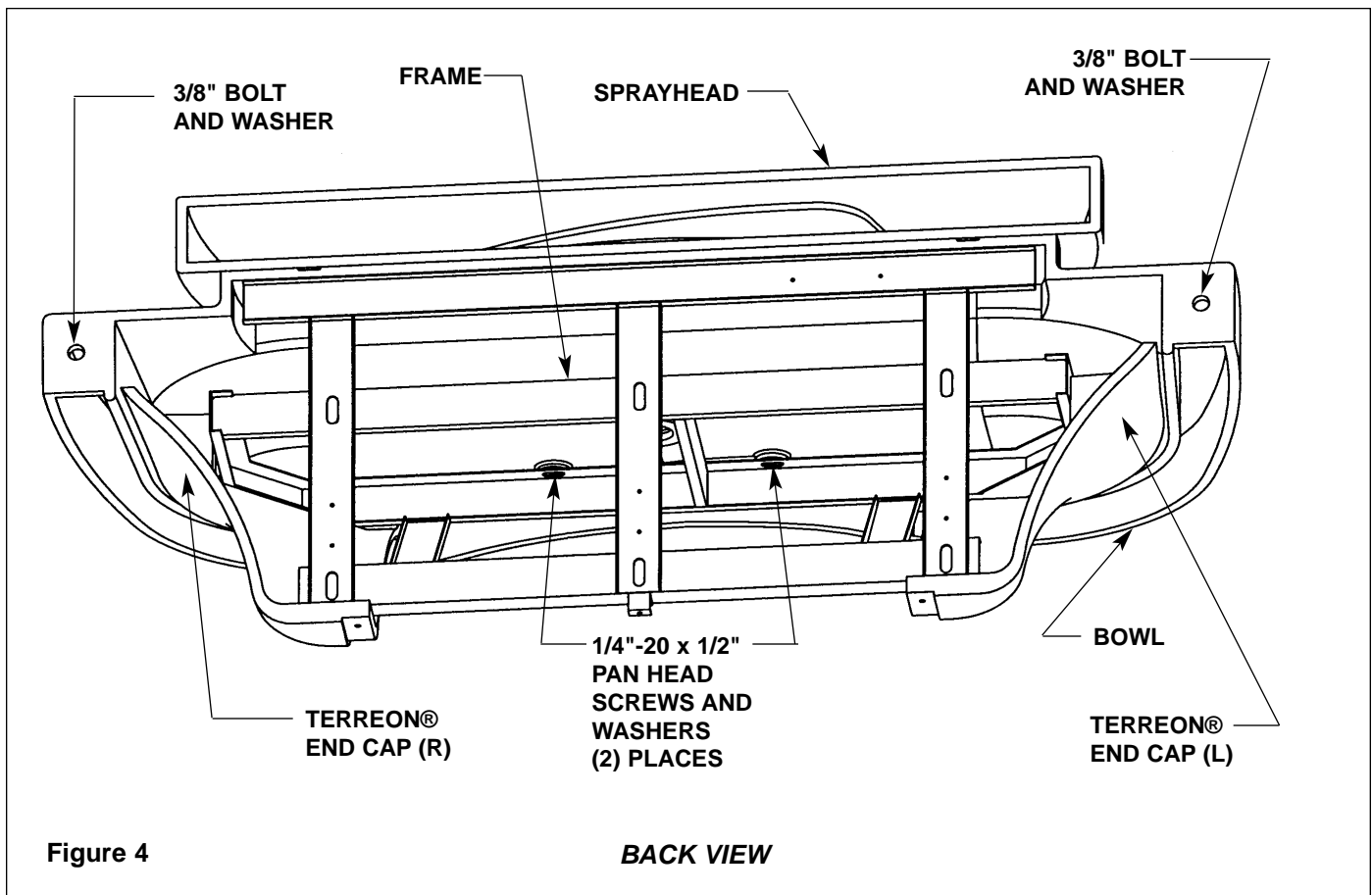

Installation Instructions *continued* . . .

Step 5: Connecting supply

1. Loosen but do not remove the two mounting screws holding the valve bracket to the frame. Slide the valve bracket up until the larger cutout in the frame's slot aligns with the screw head (see Figure 5b). Then lift up to remove the valve bracket from the frame.
2. FOR HOT AND COLD SUPPLY: Attach the stop/check to the hot and cold water supply piping from the wall. Connect the flexible hoses to the Vernatherm™ Mixing Valve and to the check/stops (see Figure 5a).

NOTE: The "H" on Vernatherm™ Mixing Valve indicates hot water supply inlet.

FOR SINGLE TEMPERED SUPPLY: Attach the stop/check to the 1/2" tempered supply line. Connect the stop/check to the tempered line adapter with the flexible supply hose (Figure 5c).

3. Assemble the P-trap by connecting the 1-1/2" tubular pipe to the tailpiece and to the 1-1/2" drain pipe stubbed out of the wall.
4. Install the strainer on the drain plug opening inside the bowl, and push the strainer firmly into place. Secure the strainer with the screw provided.

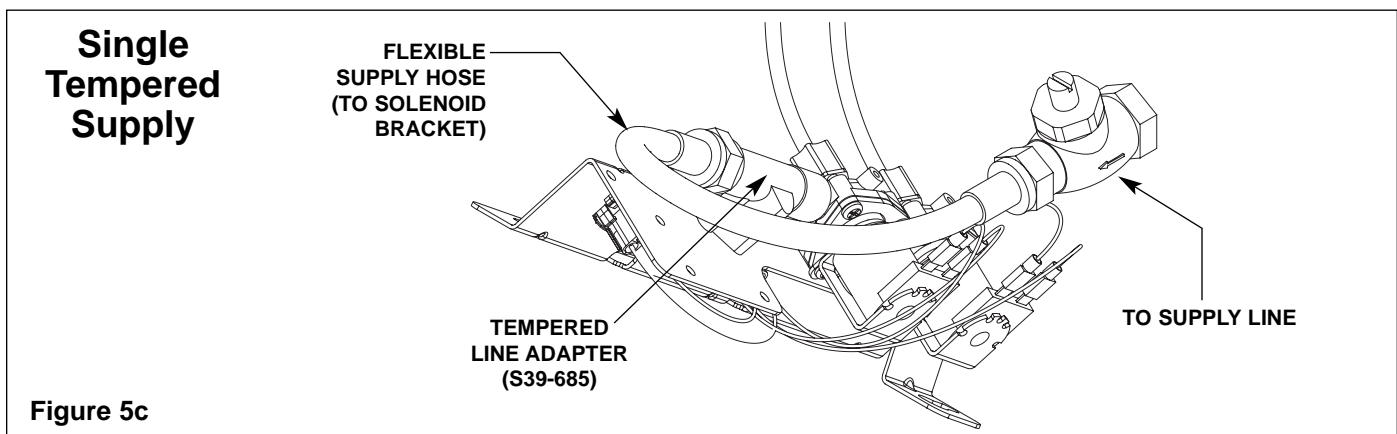
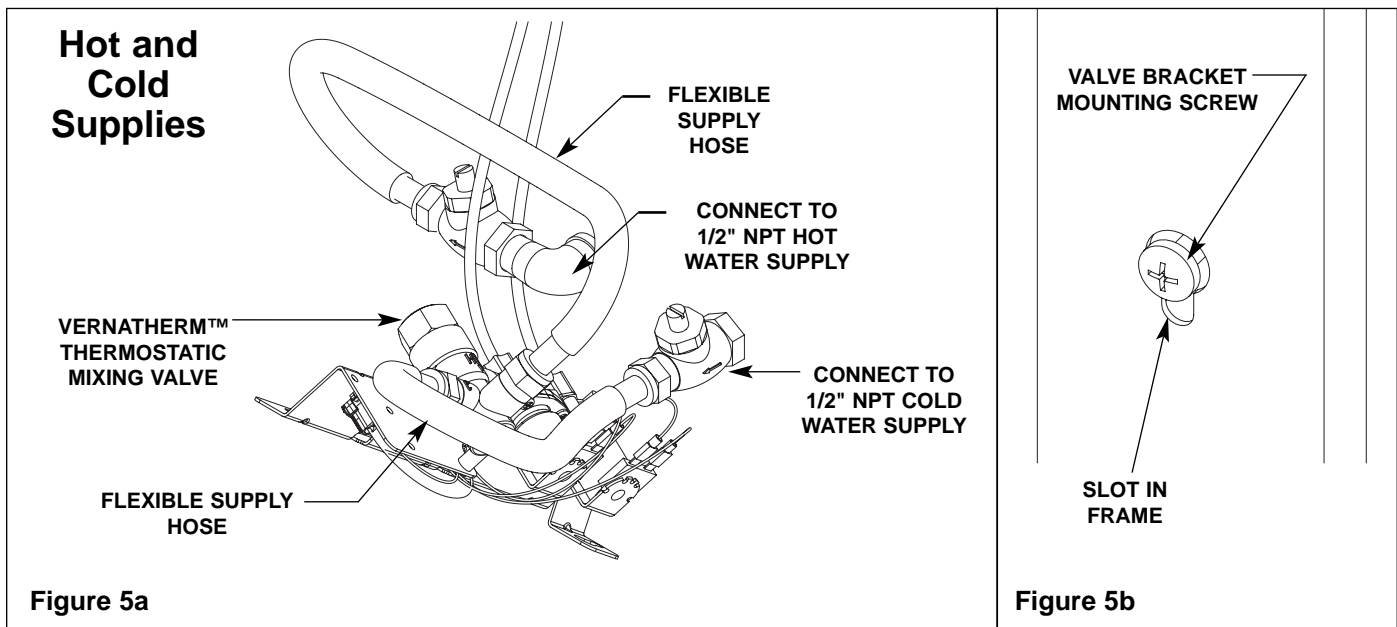

Installation Instructions *continued . . .*

Step 6: Connecting optional hot water heater

NOTE: 240/208 or 277 voltage is required for hot water heater. Refer to the installation manual provided with the hot water heater for further installation information.

1. Remove the two screws from the back of the water heater. Attach the bracket with the screws as shown in Figure 6a.
2. Hang the water heater on the rear frame member to the right of the vertical frame member (see Figure 6b).
3. Connect the 1/2" flexible hose from the cold water supply stub-out to the hot water heater inlet.
4. Connect the 1/2" flexible hose from the hot water heater outlet to the supply inlet on the solenoid valve assembly.

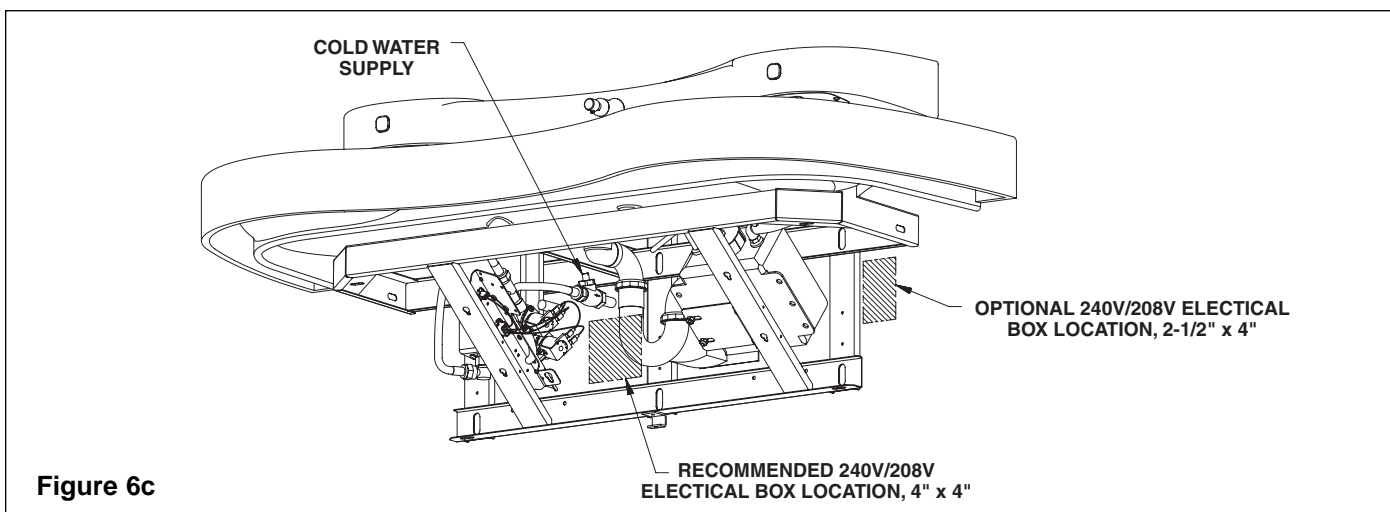
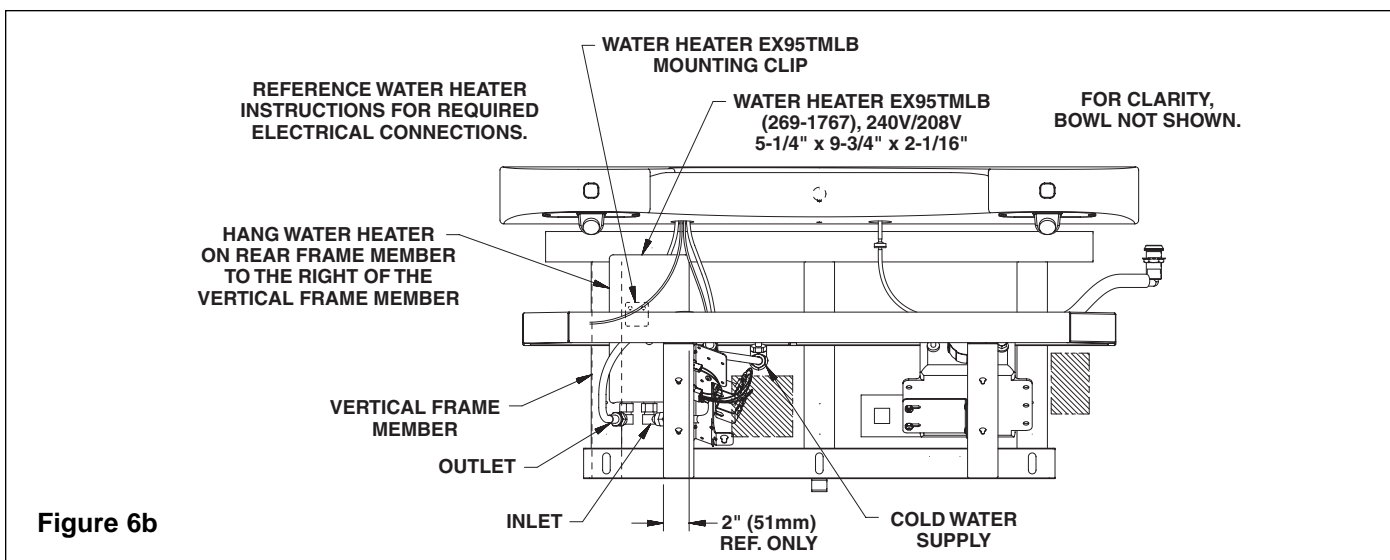
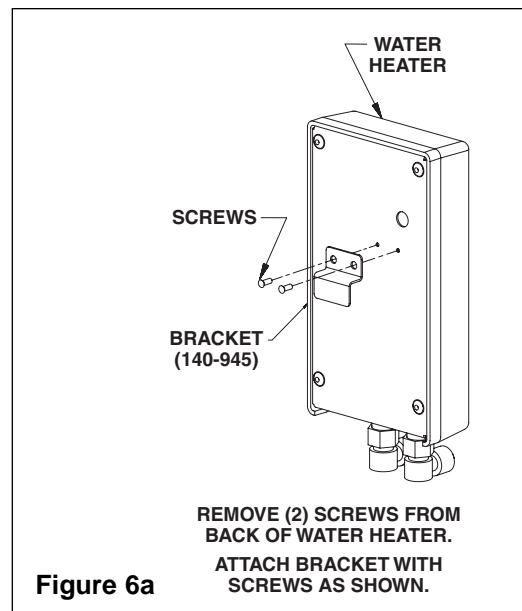

Installation Instructions *continued* . . .

Step 7: Connecting electrical and supply tubing

⚠ WARNING: MG-2/TT must be connected to 24 VAC Class II plug-in transformer provided. Connection to 110 VAC may cause personal injury and/or damage to electronics. Connection of leads other than shown may cause permanent damage to the switch.

1. Insert the two sprayhead supply tubes into the two solenoid tube connectors by loosening the compression nut and firmly pushing the tubing into the connector until the tubes are fully seated, then re-tighten the compression nut (hand-tight plus two full turns with a wrench) (see Figure 7).
2. Connect the wires per the wiring diagram shown below.
3. Align the mounting screws with slots on the frame. Valve bracket slides down to lock into place.
4. Turn on the water supply to the MG-2/TT Express® and check for leaks.
5. Turn on the electrical power, trigger the TouchTime® push buttons and check for proper function (the timing is electronically controlled and set at 15 seconds).

⚠ IMPORTANT: The Vernatherm™ valve is NOT factory-preset. Upon installation, the valve temperature must be checked and adjusted to assure delivery of safe water temperature. Water in excess of 110°F (43°C) may cause scalding.

6. Check the temperature when approximately 1.0 GPM water flow is reached and adjust if necessary (the range of the valve is 95°F–115°F (35°C–43°C). To adjust the temperature, first loosen the temperature locking nut with a wrench. Then using a blade screwdriver, turn the adjustment stem *counterclockwise* to *increase* the temperature or *clockwise* to *decrease* the temperature. Once desired temperature is reached, tighten the nut to prevent temperature change.
7. Reinstall panel to frame with the five Torx-head screws provided (see Figure 3 on page 8).

NOTE: Push button activation takes place only when released, (prevents “hold open” activation).

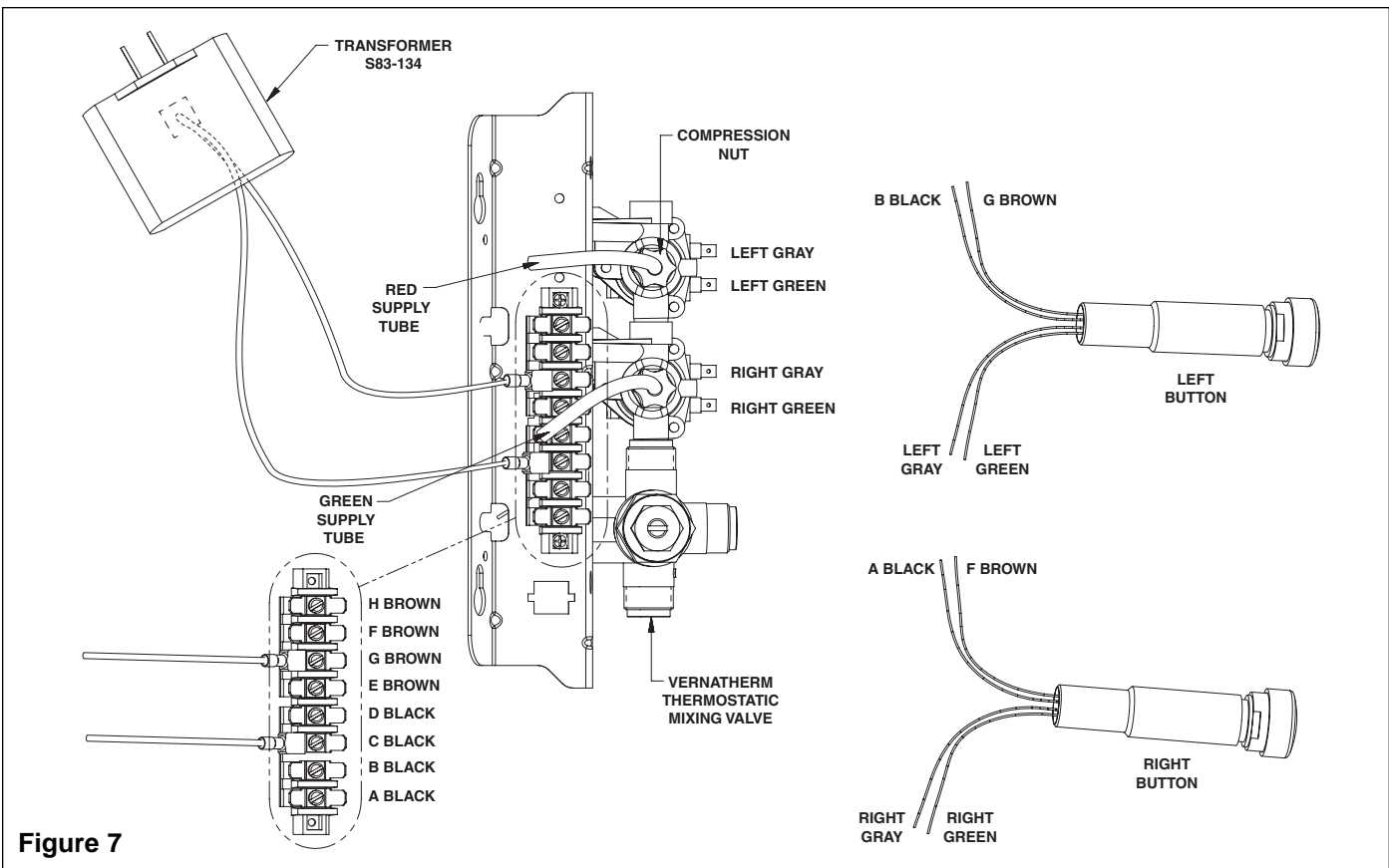

Cleaning and Maintenance Instructions



IMPORTANT: Strong alkaline or acid-based chemicals and cleansers should not be used to clean the MG-2/TT Express®. If these chemicals come in contact with the Terreon® surface, wipe off the surface immediately and flush with soapy water. Avoid unnecessary or prolonged contact with hot pans and objects.

Terreon® and panel maintenance

The bowl, sprayhead and pedestal end caps are made of Terreon®, a solid cast polyester resin material. Terreon® resists chemicals, stains, burns and impact, and is repairable with everyday cleaners or fine-grit abrasives. The panel is made of stainless steel. With regular cleaning, your MG-2/TT Express® will provide years of dependable service.

Stainless Steel Access Panel cleaning

Stainless steel is extremely durable, and maintenance is simple and inexpensive. Proper care, particularly under corrosive conditions, is essential. Ordinary deposits of dirt and grease are quickly removed with soap and water. Whenever possible, the metal should be thoroughly rinsed and dried after washing. To remove tightly adhering deposits, use stainless steel polishing powder. In all cases, rub in the direction of the stainless steel grain.



IMPORTANT: Never use ordinary steel wool or steel brushes on stainless steel. Always use stainless steel wool or stainless steel brushes.

Avoid prolonged contact with chlorides, bromides, thiocyanates, and iodides on stainless steel equipment, especially if acid conditions exist. Do not permit salty solutions to evaporate and dry on stainless steel. The appearance of rust streaks on stainless steel leads to the belief that the stainless steel is rusting. Look for the source of the rust in some iron or steel particles which may be touching, but not actually a part of the stainless steel structure. *NOTE: Strongly acidic or caustic cleaners may attack the steel causing a reddish film to appear. The use of these cleaners should be avoided.*

Terreon® Bowl, Sprayhead and Pedestal End Cap cleaning



IMPORTANT: To sustain original finish, additional care is recommended for dark colored solid surfaces to maintain highest quality color. The original luster can be maintained by periodically applying furniture polish, mineral oil or a solid surface cleaner or polish. For more information on restoring dark colors, see Bradley document #1505. Length of time between applications varies with usage.

- For regular cleaning, use standard commercial or household products such as Formula 409® or Windex®.
- Remove tough stains with Ajax®, Comet® or Soft-Scrub® and a green Scotch-Brite® pad or lightly sand in a circular motion with 240 grit wet/dry sandpaper. The finish can be renewed with a maroon Scotch-Brite® pad.
- Remove scratches with a green Scotch-Brite® pad. The finish can be renewed with a maroon Scotch-Brite® pad. Remove hard water build-up with a mild solution of vinegar and water.
- * Use of brand names is intended to indicate a type of cleaner and does not constitute an endorsement.
- ** It is emphasized that all products should be used in strict accordance with package instructions.
- **Repair kit:** A repair kit is available from Bradley to repair/patch the Terreon® bowl and shelf. Contact your Bradley representative to order a repair kit and be sure to specify color.

Assembly of Components

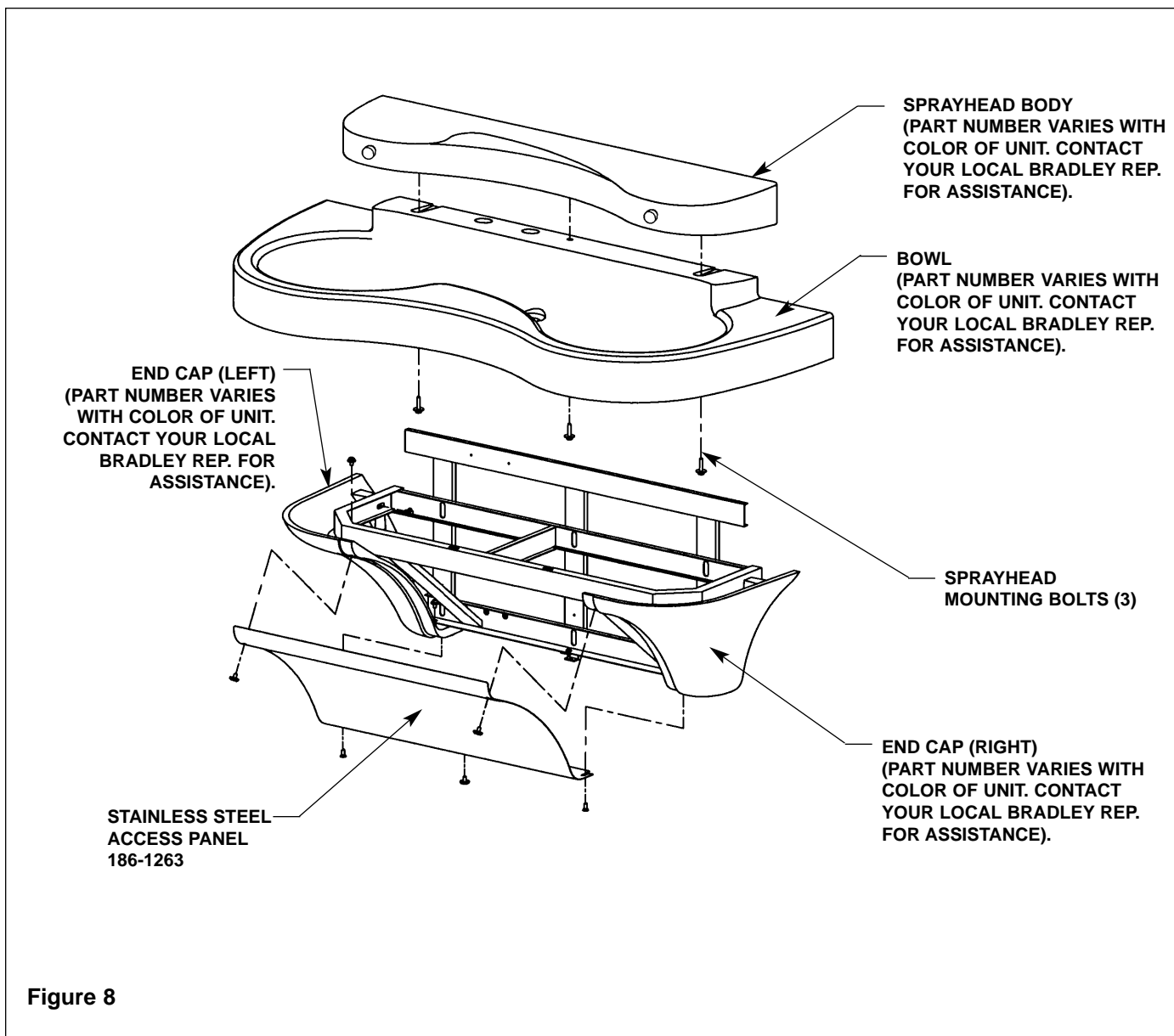

Figure 8

Assembly of Components *continued* . . .

Sensor assembly and solenoid valve access

- **To access solenoids:**

Using a 5/32" Allen socket wrench, loosen, but do not remove the three bottom access panel screws. Remove the two top access panel screws and washers securing the panel to the frame and remove the access panel (see Figure 3 on page 8). Solenoids are located on left side of frame (see Figure 9).

- **To remove sprayhead:**

Remove (3) bolts located underside of bowl neck (see Figures 8 and 10). Carefully remove sprayhead from bowl.

- **To access sprayhead/aerator/lens and sensor assembly:**

Remove (2) screws and washers from the access plate assembly using a 1/8" Allen socket wrench. The access plate assembly is located underneath the sprayhead (2) places (see Figure 11 on page 16), the assembly will drop down to access the lens, sensor, and sensor eyes, housing flow control and tube connector.

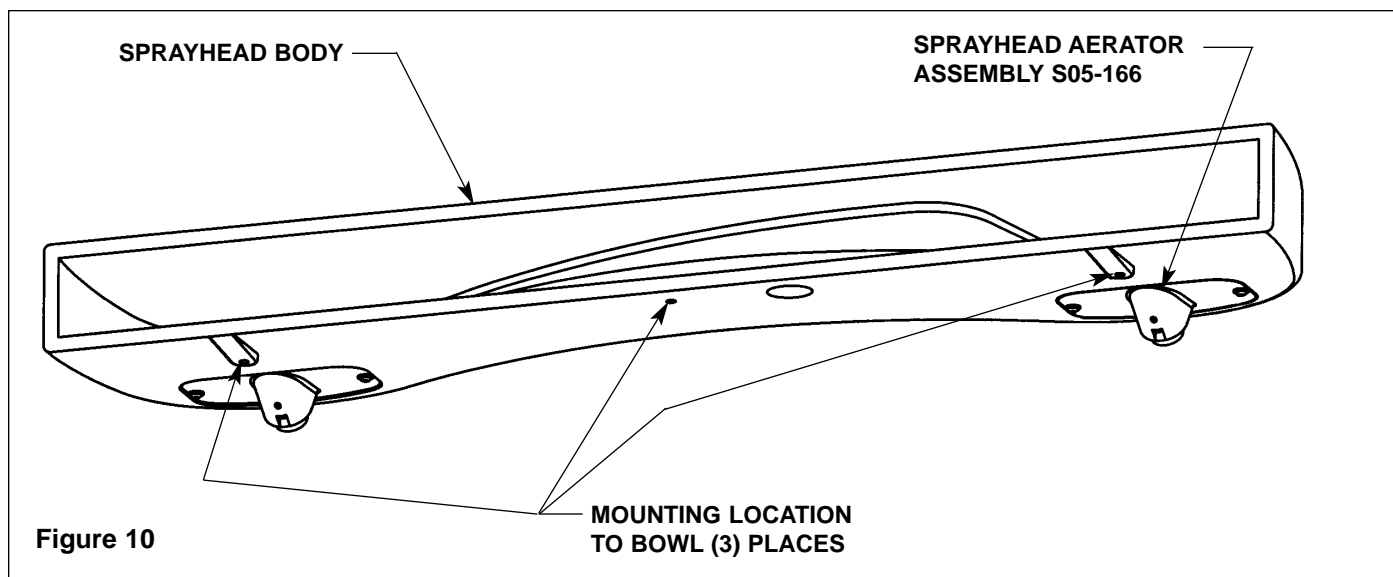
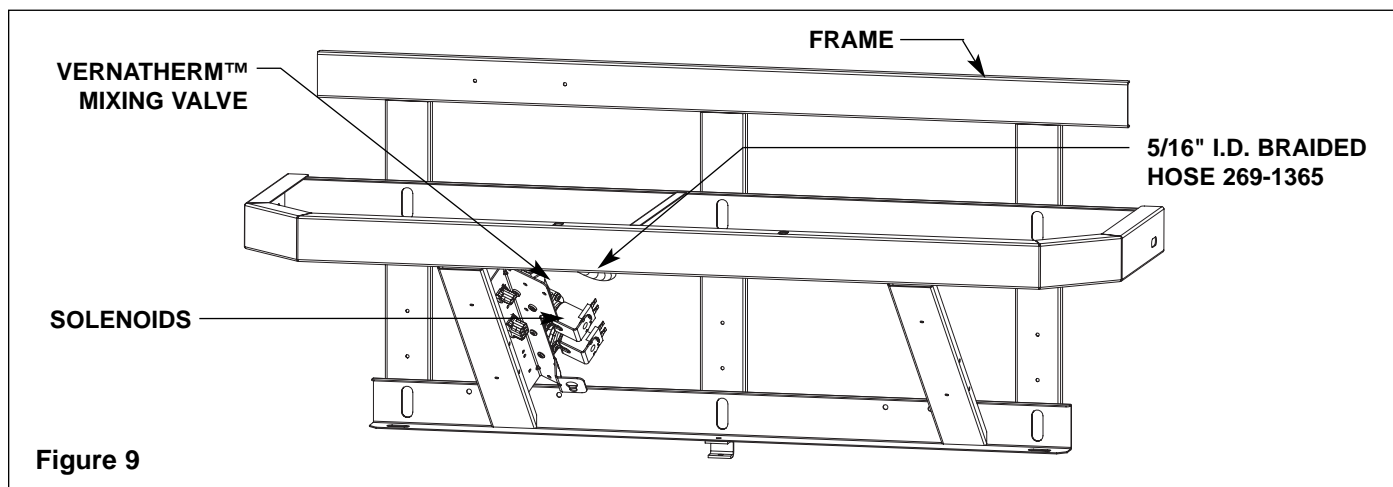

Assembly of Components *continued* . . .

TouchTime® and Aerator/Access Plate Assemblies

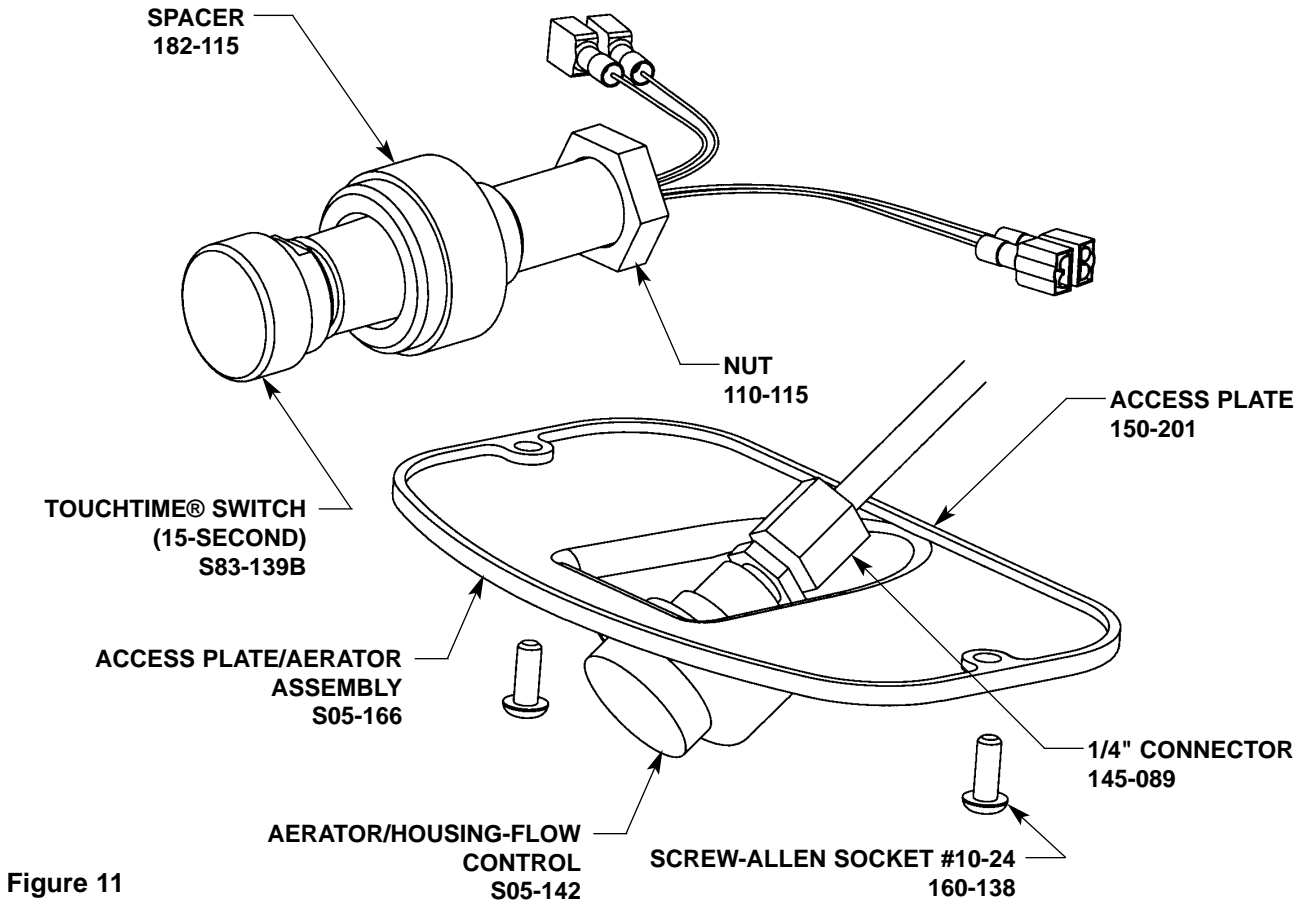
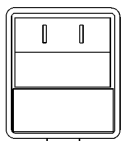

Figure 11

Other replacement parts

BOWL MOUNTING HARDWARE

- (4) 1/4"-20 x 1/2" PAN HEAD SCREW 160-389
- (4) 1/4"-20 WASHER 142-002DB



110-24 VAC CLASS II PLUG-IN TRANSFORMER S83-134

DRAIN ASSEMBLY

- P-TRAP 269-1697 (polypropylene)
- S29-094 (chrome-plated brass)

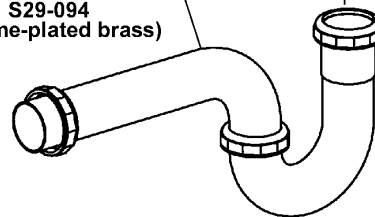

- #8-32 SCREW 160-319
- STRAINER P16-075
- DRAIN PLUG P16-072
- 1/8" RUBBER WASHER 125-001DP

TAILPIECE 129-056

Troubleshooting Solenoid Valve (VAC)



CAUTION: Turn off electrical and water supplies to unit before troubleshooting.

Problem: An individual operating station fails to shut off and drips.

Cause: There is debris trapped between the diaphragm and the valve seat.

Solution: Remove debris between diaphragm and the valve seat.

1. Remove the three #8 Phillips-head screws that hold the solenoid valve assembly together. Be careful not to lose the armature or spring (see Figure 12 on page 18).
2. Remove the diaphragm. Remove any particles that have been trapped between the diaphragm and the valve seat. Rinse off the diaphragm and inspect for damage. Make sure the center orifice and both small side orifices are open.
3. Reassemble in reverse order, being careful not to overtighten the Phillips-head screws or you may crack the plastic valve body. Tighten until the armature plate makes contact with the plastic body.
4. Reconnect the wiring per diagram on page 12.

Problem: An individual operating station fails to turn on.

Cause: A failed coil for the valve or loose electrical connection to the terminal.

Solution: Test the station to determine cause.

1. Disconnect the wires from the coil of an adjacent valve. Disconnect the wires from the problem valve and reconnect to the adjacent valve.
2. Turn on electrical and water supplies to the unit. Pass your hand in front of the sensor of the problem station, and the adjacent station should turn on.

If the adjacent station turns on and cycles normally, replace the coil on the problem valve.

If the adjacent valve fails to turn on, inspect the wires from the sensor cable and do the following:

- make sure there are no breaks and that the fully insulated disconnect terminals are firmly crimped in place;
- turn off the electrical and water supplies;
- reconnect to the adjacent valve and turn on the electrical and water supplies to the unit;
- pass your hand in front of the sensor. If the station still fails to turn on, replace the sensor (see page 18).

Solenoid Valve S07-067 (closed body) and S07-067A (thru body)

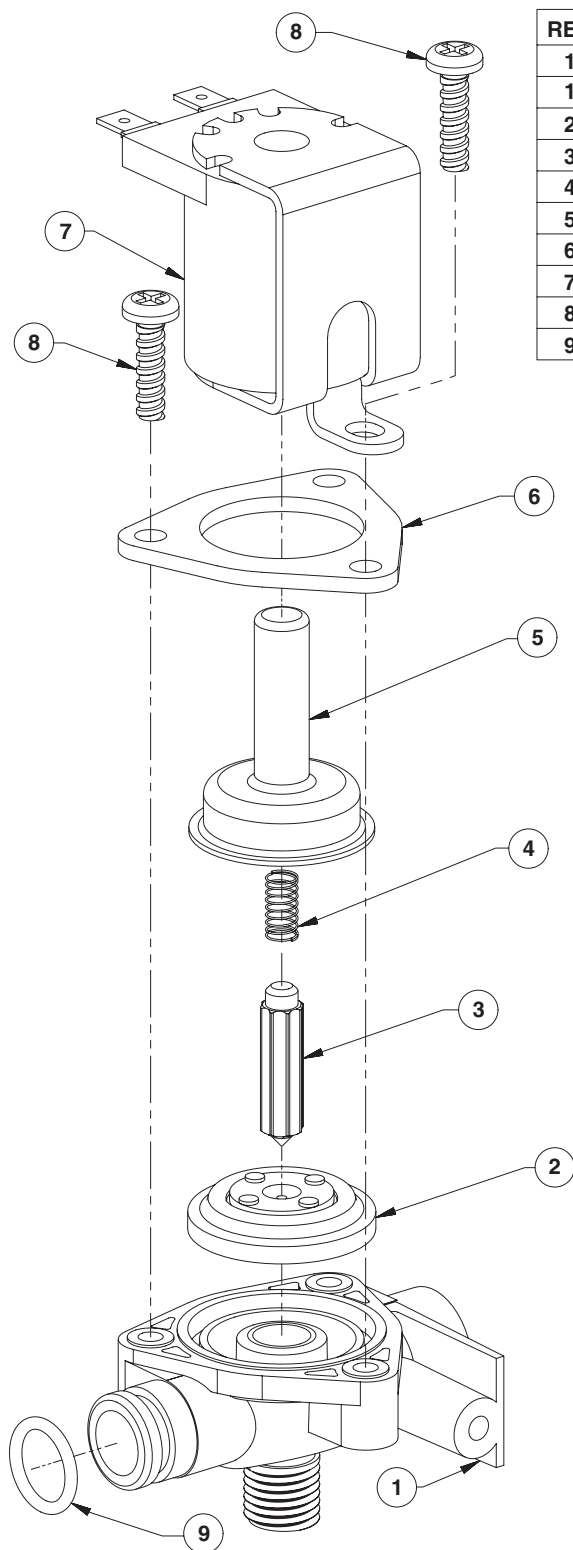

REF.	QTY.	PART NO.	DESCRIPTION
1	1	118-307	VALVE BODY, 1/4" CLOSED
1	1	118-307A	VALVE BODY, 1/4" THRU
2	1	269-983	DIAPHRAGM
3	1	269-577	ARMATURE
4	1	269-578	SPRING
5	1	269-1729	ARMATURE HOUSING
6	1	269-1730	CLAMP, ARMATURE HOUSING
7	1	269-579	COIL, SOLENOID VALVE
8	3	160-447	SCREW, #8 X 5/8
9	1	125-165	O-RING, #2-013

Figure 12

Thermostatic Mixing Valve Maintenance and Troubleshooting

NOTE: Before attempting to troubleshoot the valve or disassemble the components, check for the following conditions:

- *If stop/check valves are used, make sure that they are fully open.*
- *Make sure that the hot and cold inlet pipes are connected properly, and that there are no cross-connections or leaking stop/check valves.*
- *Check the hot water heater output to make sure that it is at least 20° F above the set temperature.*

Be sure to close the appropriate shut-off valves prior to disassembly of the valve and reopen the valves after inspection and repair is complete.

Problem: Limited water flow

Cause: Dirt and debris have built up in the valve or strainer.

1. Remove and clean strainer (see Figure 13 or 14 on page 20). If strainer needs to be replaced, order Bradley part no. 173-028.
2. Check the piston for smooth movement.

To check the valve's piston for free and smooth movement, follow the procedures outlined below:

1. Remove the valve's cap and thermostat (see Figure 13 on page 20).
2. Push down on the piston with your finger (the piston should move freely). If the movement is not as it should be, the piston needs to be cleaned. Follow the method outlined below for cleaning the piston and valve body:
 - Remove the thermostat.
 - Lift the piston out with a needle-nose pliers and remove the spring.
 - Any cleaner suitable for brass and stainless steel may be used (if cleaning with suitable cleaner is not sufficient to remove debris, a 400-grit sandpaper may be used to polish and hone the piston and valve body).
 - Snap spring into piston (will detent) and reassemble into the valve body. Retest the piston.
3. If, after a thorough cleaning, the piston does not move freely, the piston must be replaced. Contact your Bradley representative and ask for Repair Kit (part number S65-259).

Problem: External leaks in the system

Cause: O-rings have been damaged.

Solution: Replace O-rings where necessary. For replacement of the O-rings, contact your Bradley representative and ask for Repair Kit (part number S65-259).

Problem: Improper water temperature or temperature fluctuation

Cause: Thermostat is slowly failing or not working at all.

Solution: Check the thermostat for proper operation.

1. At room temperature (80° F or less) remove cap and thermostat.
2. Place thermostat into container with 115° F water. The pushrod should pop out of the thermostat approximately 1/10".
3. If thermostat pushrod does not pop out, the thermostat must be replaced. Contact your Bradley representative and ask for Repair Kit (part number S65-259).

Cause: Valve temperature is not properly set.

Solution: Adjust the temperature. Using a blade screwdriver, turn the adjustment stem **counterclockwise** to **increase** the temperature or **clockwise** to **decrease** the temperature.

Vernatherm™ Thermostatic Mixing Valve (S01-524)

Repair Kit S65-259

Item	Qty	Description
5	1	Thermostat
7	1	O-Ring
8	1	O-Ring

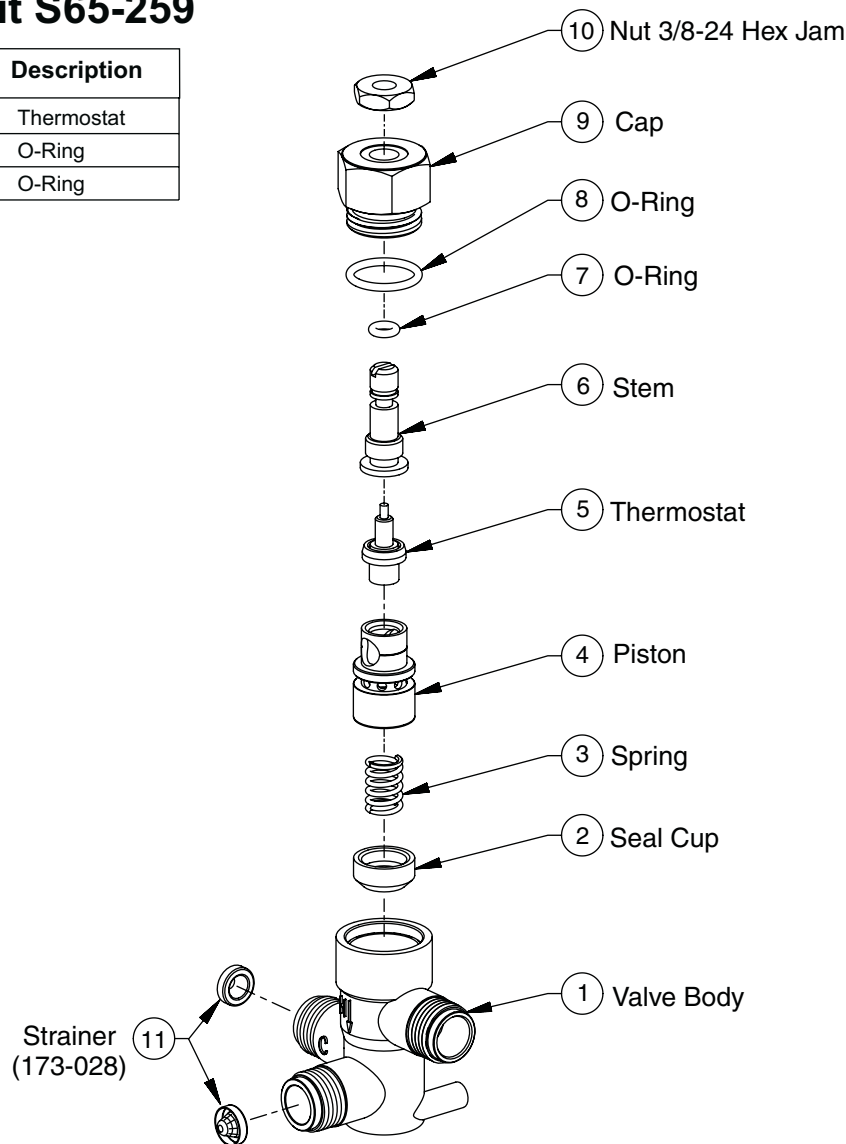
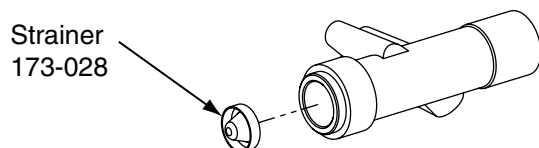

Figure 13

Tempered Line Adapter Assembly (S39-685) Option

Figure 14



Free Manuals Download Website

<http://myh66.com>

<http://usermanuals.us>

<http://www.somanuals.com>

<http://www.4manuals.cc>

<http://www.manual-lib.com>

<http://www.404manual.com>

<http://www.luxmanual.com>

<http://aubethermostatmanual.com>

Golf course search by state

<http://golfingnear.com>

Email search by domain

<http://emailbydomain.com>

Auto manuals search

<http://auto.somanuals.com>

TV manuals search

<http://tv.somanuals.com>