

RMC 7132

1U Rackmount System

User Manual

RMC7132: 1U Rackmount Computer comes with
Intel Xeon 5600/ 5500, 3600/3500, i7 series Processor

ACNODES

661 Brea Canyon Rd., Suite 3
Walnut, CA 91789
tel: 909.598.7388, fax: 909.598.0218

© Copyright 2009 Acnodes, Inc.
All rights reserved. Product description and product specifications
are subject to change without notice. For latest product information,
please visit Acnodes' web site at www.acnodes.com.



RMC 7132

1U Rackmount System

The information in this User's Manual has been carefully reviewed and is believed to be accurate. The vendor assumes no responsibility for any inaccuracies that may be contained in this document, makes no commitment to update or to keep current the information in this manual, or to notify any person or organization of the updates. Please Note: For the most up-to-date version of this manual, please see our web site at www.supermicro.com.

Acnodes Corporation, reserves the right to make changes to the product described in this manual at any time and without notice. This product, including software, if any, and documentation may not, in whole or in part, be copied, photocopied, reproduced, translated or reduced to any medium or machine without prior written consent.

IN NO EVENT WILL SUPERMICRO BE LIABLE FOR DIRECT, INDIRECT, SPECIAL, INCIDENTAL, SPECULATIVE OR CONSEQUENTIAL DAMAGES ARISING FROM THE USE OR INABILITY TO USE THIS PRODUCT OR DOCUMENTATION, EVEN IF ADVISED OF THE POSSIBILITY OF SUCH DAMAGES. IN PARTICULAR, ACNODES SHALL NOT HAVE LIABILITY FOR ANY HARDWARE, SOFTWARE, OR DATA STORED OR USED WITH THE PRODUCT, INCLUDING THE COSTS OF REPAIRING, REPLACING, INTEGRATING, INSTALLING OR RECOVERING SUCH HARDWARE, SOFTWARE, OR DATA.

Any disputes arising between manufacturer and customer shall be governed by the laws of Santa Clara County in the State of California, USA. The State of California, County of Santa Clara shall be the exclusive venue for the resolution of any such disputes. Acnodes's total liability for all claims will not exceed the price paid for the hardware product.

FCC Statement: This equipment has been tested and found to comply with the limits for a Class A digital device pursuant to Part 15 of the FCC Rules. These limits are designed to provide reasonable protection against harmful interference when the equipment is operated in a commercial environment. This equipment generates, uses, and can radiate radio frequency energy and, if not installed and used in accordance with the manufacturer's instruction manual, may cause harmful interference with radio communications. Operation of this equipment in a residential area is likely to cause harmful interference, in which case you will be required to correct the interference at your own expense.

California Best Management Practices Regulations for Perchlorate Materials: This Perchlorate warning applies only to products containing CR (Manganese Dioxide) Lithium coin cells. "Perchlorate Material-special handling may apply. See www.dtsc.ca.gov/hazardouswaste/perchlorate"

WARNING: Handling of lead solder materials used in this product may expose you to lead, a chemical known to the State of California to cause birth defects and other reproductive harm.

Manual Revision 1.0

Release Date: April 26, 2010

Unless you request and receive written permission from Acnodes Corporation., you may not copy any part of this document.

Information in this document is subject to change without notice. Other products and companies referred to herein are trademarks or registered trademarks of their respective companies or mark holders.

Copyright © 2009 by Acnodes Corporation. All rights reserved.

Printed in the United States of America

ACNODES

661 Brea Canyon Rd., Suite 3
Walnut, CA 91789
tel: 909.598.7388, fax: 909.598.0218

© Copyright 2005 Acnodes, Inc.
All rights reserved. Product description and product specifications
are subject to change without notice. For latest product information,
please visit Acnodes' web site at www.acnodes.com.



RMC 7132

1U Rackmount System

Preface

About This Manual

This manual is written for professional system integrators and PC technicians. It provides information for the installation and use of the Acnodes RMC7132. Installation and maintenance should be performed by experienced technicians only.

Manual Organization

Chapter 1: Introduction

The first chapter provides a checklist of the main components included with the server system and describes the main features of the embedded board and the RMC7132 chassis.

Chapter 2: Server Installation

This chapter describes the steps necessary to install the Acnodes RMC7132 into a rack and check out the server configuration prior to powering up the system. If your server was ordered without the processor and memory components, this chapter will refer you to the appropriate sections of the manual for their installation.

Chapter 3: System Interface

Refer to this chapter for details on the system interface, which includes the functions and information provided by the control panel on the chassis as well as other LEDs located throughout the system.

Chapter 4: System Safety

You should thoroughly familiarize yourself with this chapter for a general overview of safety precautions that should be followed when installing and servicing the Acnodes RMC7132.



RMC 7132

1U Rackmount System

Chapter 5: Advanced Motherboard Setup

Chapter 5 provides detailed information on the embedded board, including the locations and functions of connectors, headers and jumpers. Refer to this chapter when adding or removing processors or main memory and when reconfiguring the motherboard.

Chapter 6: Advanced Chassis Setup

Refer to Chapter 6 for detailed information on the RMC7132 1U rackmount server chassis. You should follow the procedures given in this chapter when installing, removing or reconfiguring drives and when replacing system power supply units and cooling fans.

Chapter 7: BIOS

The BIOS chapter includes an introduction to BIOS and provides detailed information on running the CMOS Setup Utility.

Appendix A: POST Error Beep Codes

Appendix B: Installing the Windows OS

Appendix C: System Specifications



RMC 7132

1U Rackmount System

Table of Contents

CHAPTER 1 INTRODUCTION

1-1	Overview	1
1-2	Motherboard Features.....	2
	Processor	2
	Memory	2
	Onboard SATA.....	2
	PCI Expansion Slots	2
	Onboard Controllers/Ports	2
1-3	Server Chassis Features	4
	System Power	4
	SATA Subsystem	4
	Control Panel	4
	Rear I/O Panel	4
	Cooling System	4

CHAPTER 2 INSTALLATION

2-1	Overview.....	5
2-2	Unpacking the System	5
2-3	Preparing for Setup	5
	Choosing a Setup Location.....	5
	Rack Mounting Considerations	7
	Ambient Operating Temperature	7
	Reduced Airflow	7
	Mechanical Loading	7
2-4	Installing the System in to a Rack.....	8
	Installing the Chassis Rails.....	8
	Installing the Rack Rails.....	8



RMC 7132

1U Rackmount System

2-5	Checking the Motherboard Setup	12
-----	--------------------------------------	----

2-6	Checking the Drive Bay Setup.....	14
-----	-----------------------------------	----

CHAPTER 3 System Interface

3-1	Overview	16
-----	----------------	----

3-2	Control Panel Buttons	16
-----	-----------------------------	----

Reset Button	16
--------------------	----

Power	16
-------------	----

3-3	Control Panel LEDs	17
-----	--------------------------	----

Overheat/ Fan FAil.....	17
-------------------------	----

NIC2	17
------------	----

NIC1	17
------------	----

HDD.....	17
----------	----

Power	18
-------------	----

3-4	SerialATA Drive Carrier LEDs.....	19
-----	-----------------------------------	----

CHAPTER 4 SYSTEM SAFETY

4-1	Electrical Safety Precautions	19
-----	-------------------------------------	----

4-2	General Safety Precautions	20
-----	----------------------------------	----

4-3	ESD Precautions	21
-----	-----------------------	----

4-4	Operating Precautions	22
-----	-----------------------------	----

CHAPTER 5 ADVANCED MOTHERBOARD SETUP

5-1	Handling the Motherboard	23
-----	--------------------------------	----

Precautions	23
-------------------	----

Unpacking.....	23
----------------	----

5-2	Serverboard Installation.....	23
-----	-------------------------------	----

5-3	Connecting Cables.....	24
-----	------------------------	----

Connecting Data Cables.....	24
-----------------------------	----

Connecting Power Cables.....	25
------------------------------	----



RMC 7132

1U Rackmount System

	Connecting the Control Panel	25
5-4	I/O Ports	26
5-5	Installing the Processor and Heatsink.....	27
	Installing an LGA1366 Processor.....	27
	Installing a Passive CPU Heatsink.....	28
	Removing the Heatsink.....	29
5-6	Installing Memory Modules.....	30
	Installing & Removing DIMMs.....	30
	Memory Support.....	31
5-7	Adding PCI Expansion Cards	32
5-8	Serverboard Details	33
	X8STi Quick Reference.....	34
5-9	Connector Definitions	35
	Main ATX Power Supply Connector	35
	Processor Power Connector.....	35
	External Power Connector	35
	Power Button	35
	Reset Button.....	35
	Power Fail LED	35
	Overheat/Fan Fail.....	36
	NIC2 (LAN2) LED.....	36
	NIC1 (LAN1) LED.....	36
	HDD LED/ UID Switch.....	36
	Power On LED	36
	NMI Button.....	37
	Fan Headers.....	37
	ATX PS/2 Keyboard and PS/2 Mouse Ports.....	37

RMC 7132

1U Rackmount System

Serial Ports.....	37
Chassis Intrusion	38
Wake-On-LAN.....	38
External Speaker/ Internal Buzzer.....	38
Overheat/ Fan Fail LED.....	38
Onboard Power LED	38
Universal Serial Bus (USB).....	39
SGPIO Headers.....	39
Power Supply SMBus Header.....	39
LAN 1/2 (Ethernet Ports).....	39
Power Supply Fail LED Header.....	40
Alarm Reset.....	40
I-Button.....	40
Unit Identifier Button.....	40
5-10 Jumper Setting.....	41
Explanation of Jumpers.....	41
CMOS Clear.....	41
VGA Enable/Disable.....	41
LAN 1/2 Enable/ Disable.....	42
Watch Dog Enable/ Disable.....	42
USB Wake-up.....	42
SMBus to PCI Slots.....	43
BMC Enable/Disable.....	43
5.11 Onboard Indicators.....	44
LAN1/2 LEDs.....	44
Onboard Power LED (LE1)	44
UID LED	44



RMC 7132

1U Rackmount System

BMC Heartbeat LED	44
5.12 Floppy and SATA Ports.....	46
Floppy Drive Connector	46
SATA Ports	46
5-13 Installaing Software.....	47
Doctor III.....	48

CHAPTER 6 ADVANCED CHASSIS SETUP

6-1 Static-Sensitive Devices.....	50
Precautions	50
Unpacking.....	50
6-2 Control Panel	51
6-3 System Fans	52
System Fan Failure.....	52
6-4 Drive Bay Installation/Removal	53
Accessing the Drive Bays.....	53
Serial ATA Drive Installation.....	55
SATA Power Cables.....	56
DVD-ROM Drive Installation.....	56
Power Supply Failure.....	57

CHAPTER 7 BIOS

7-1 Introduction.....	56
Starting BIOS Setup Utility.....	56
How To Change the Configuration Data	56
Starting the Setup Utility	57
7-2 Main Setup	57
7-3 Advanced Setup Configurations.....	59
7-4 Security Settings	78



7-5 Boot Configuration.....79

7-6 Exit Options80

Appendix A POST Error Beep Codes

Appendix B Installing the Windows OS

Appendix C System Specifications



RMC 7132

1U Rackmount System

CHAPTER 1 INTRODUCTION

1.1 Overview

The Acnodes RMC7132 is a high-end single processor, 1U rack-mount server. The RMC7132 is comprised of two main subsystems: the RMC7132 chassis and the embedded board. Please refer to our web site for information on operating systems that have been certified for use with the RMC7132.

In addition to the mainboard and chassis, various hardware components may have been included with the RMC7132, as listed below.

- o One CPU heatsink
- o Two 10-cm blower fans
- o One air shroud
- o One slim DVD-ROM drive
- o One internal USB cable for DVD-ROM drive
- o One SATA to USB adapter for DVD-ROM drive
- o SATA Accessories:
 - One internal SATA backplane
 - Two sets of SATA cables
 - One SGPIO cable
 - Two 3.5" SATA drive carriers
- o One PCI-E x16 slot riser card
- o Rackmount hardware with screws
- o One CD containing drivers and utilities
- o Acnodes RMC7132 User's Manual

Note: "B" indicates black.



RMC 7132

1U Rackmount System

1-2

Motherboard Features

At the heart of the Acnodes RMC7132 lies the embedded board, a single processor motherboard based upon Intel's X58 chipset. Below are the main features of the embedded board.

Processor

The embedded board supports single Intel® Core™ i7, Core™ i7 Extreme processors and future Intel Nehalem processor families (next generation Intel Xeon® processor). Please refer to the motherboard specifications pages on our web site for updates on supported processors.

Memory

The embedded board has six 240-pin DIMM slots that can support up to 24 GB of unbuffered ECC/non-ECC DDR2-1333/1066/800 SDRAM.

Onboard SATA

A SATA controller is built in to the ICH10R portion of the chipset to provide support for a six port, 3 Gb/sec Serial ATA subsystem. The SATA drive is not hot-swappable units.

PCI Expansion Slots

The embedded board has one PCI-E 2.0 x16 slot for use in the RMC7132 server. The PCI-E slots may be populated with a riser card (included).

Onboard Controllers/Ports

An onboard IDE controller supports one floppy drive. Onboard I/O backpanel ports include one COM port, a VGA port, two USB ports, PS/2 mouse and keyboard ports and four Gigabit LAN (NIC) ports.

Other Features

Other onboard features that promote system health include voltage monitors, a chassis intrusion header, auto-switching voltage regulators, chassis and CPU overheat sensors, virus protection and BIOS rescue.



661 Brea Canyon Rd., Suite 3
Walnut, CA 91789
tel: 909.598.7388, fax: 909.598.0218

© Copyright 2005 Acnodes, Inc.
All rights reserved. Product description and product specifications are subject to change without notice. For latest product information, please visit Acnodes' web site at www.acnodes.com.

RMC 7132

1U Rackmount System

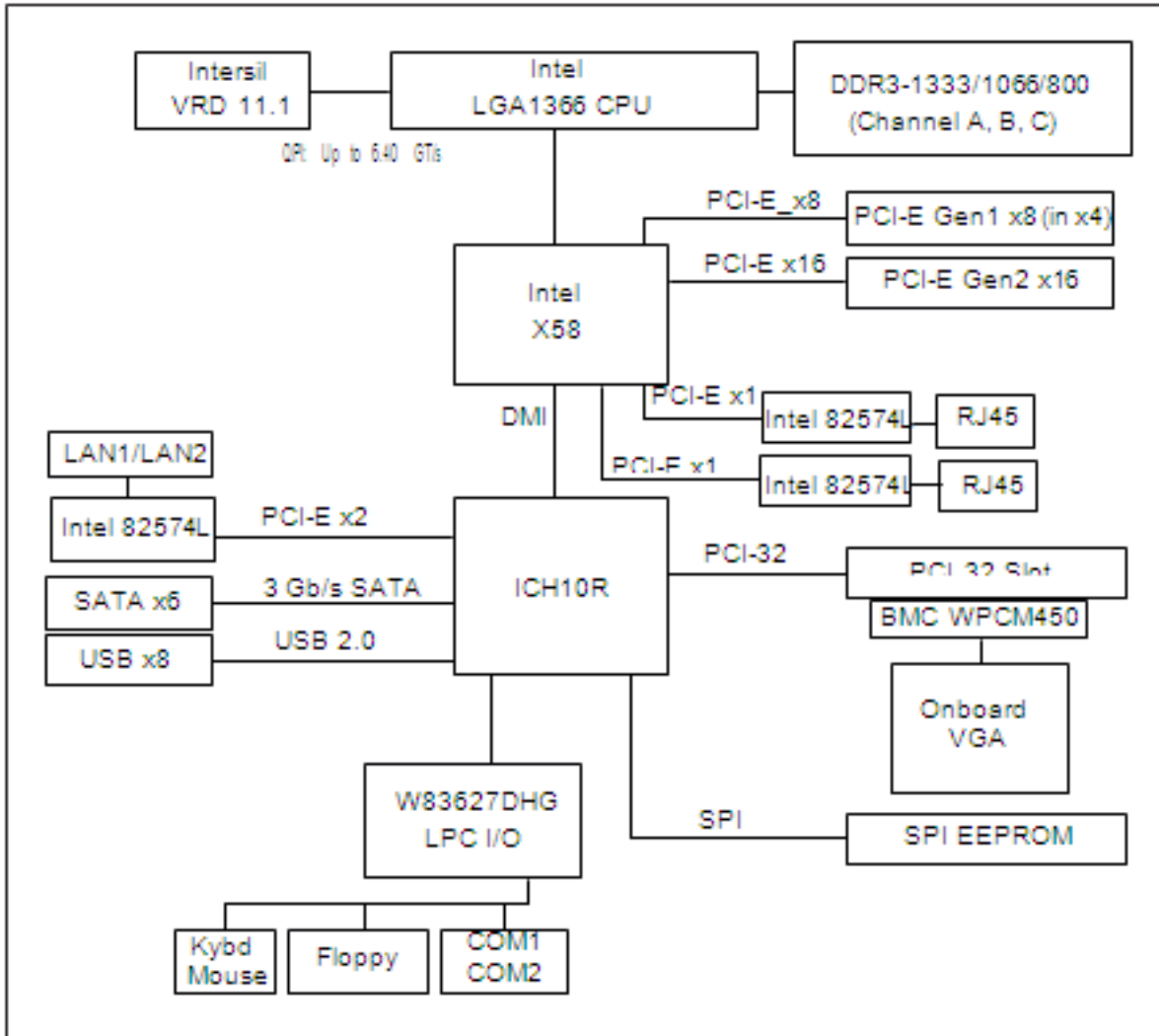

Figure 1-1. Intel Chipset: System Block Diagram

Note: This is a general block diagram. Please see Chapter 5 for details.



RMC 7132

1U Rackmount System

1-3 Server Chassis Features

The following is a general outline of the main features of the RMC7132 chassis.

System Power

The RMC7132 chassis includes a single 280W power supply.

SATA Subsystem

The RMC7132 chassis was designed to support one internal 3.5" Serial ATA hard drive. This SATA drive is not hot-swappable; power must be removed from the system before installing or replacing. ATA/100 IDE drives can be alternately supported.

Note: The operating system you use must have RAID support to enable the hot- swap capability of the SATA drives.

Control Panel

The control panel on the RMC7132 provides important system monitoring and control information. LEDs indicate power on, network activity, hard disk drive activity and system overheat conditions. The control panel also includes a main power button and a system reset button.

Rear I/O Panel

The rear I/O panel on the RMC7132 provides one motherboard expansion slot, one COM port (another is internal), two USB ports, PS/2 mouse and keyboard ports, a graphics port and two Gb Ethernet ports.

Cooling System

The RMC7132 chassis has an innovative cooling design that features one 10-cm blower-type system cooling fan. The blower fan plugs into a chassis fan header on the motherboard and an air shroud channels the airflow to efficiently cool the processor area.

A fan speed control setting in BIOS allows fan speed to be determined by system temperature [the recommended setting is 3-pn (Server)].



RMC 7132

1U Rackmount System

CHAPTER 2 INSTALLATION

2-1 Overview

This chapter provides a quick setup checklist to get your Acnodes RMC7130 and running. Following the steps in the order given should enable you to have the system operational within a minimal amount of time. This quick setup assumes that your RMC7130 system has come to you with the processor and memory preinstalled. If your system is not already fully integrated with a motherboard, processor, system memory etc., please turn to the chapter or section noted in each step for details on installing specific components.

2-2 Unpacking the System

You should inspect the box the Acnodes RMC7130 was shipped in and note if it was damaged in any way. If the server itself shows damage, you should file a damage claim with the carrier who delivered it.

Decide on a suitable location for the rack unit that will hold the Acnodes RMC7130. It should be situated in a clean, dust-free area that is well ventilated. Avoid areas where heat, electrical noise and electromagnetic fields are generated. You will also need it placed near a grounded power outlet. Read the Rack and Server Precautions in the next section.

2-3 Preparing for Setup

The Acnodes RMC7130 does not ship with a rack rail hardware package as the system can be rack mounted without the use of rails. An optional rack rail package is available if you wish to order from Supermicro. Follow the steps in the order given to complete the installation process in a minimal amount of time. Please read this section in its entirety before you begin the installation procedure outlined in the sections that follow.

Choosing a Setup Location

o Leave enough clearance in front of the rack to enable you to open the front door completely (~25 inches) and approximately 30 inches of clearance in the back of the rack to allow for sufficient airflow and ease in servicing. This product is for installation only in a Restricted Access Location (dedicated equipment rooms, service closets, etc.).

o This product is not suitable for use with visual display work place devices according to §2 of the German Ordinance for Work with Visual Display Units.



RMC 7132

1U Rackmount System



Warnings and Precautions!



Rack Precautions

- o Ensure that the leveling jacks on the bottom of the rack are fully extended to the floor with the full weight of the rack resting on them.
- o In a single rack installation, stabilizers should be attached to the rack.
- o In multiple rack installations, the racks should be coupled together.
- o Always make sure the rack is stable before extending a component from the rack.
- o You should extend only one component at a time - extending two or more simultaneously may cause the rack to become unstable.

Server Precautions

- o Review the electrical and general safety precautions in Chapter 4.
- o Determine the placement of each component in the rack before you install the rails.
- o Install the heaviest server components on the bottom of the rack first, and then work up.
- o Use a regulating uninterruptible power supply (UPS) to protect the server from power surges, voltage spikes and to keep your system operating in case of a power failure.
- o Allow the power supply units and hot plug Serial ATA drives to cool before touching them.
- o Always keep the rack's front door and all panels and components on the servers closed when not servicing to maintain proper cooling.



RMC 7132

1U Rackmount System

Rack Mounting Considerations

Ambient Operating Temperature

If installed in a closed or multi-unit rack assembly, the ambient operating temperature of the rack environment may be greater than the ambient temperature of the room. Therefore, consideration should be given to installing the equipment in an environment compatible with the manufacturer's maximum rated ambient temperature (T_{mra}).

Reduced Airflow

Equipment should be mounted into a rack so that the amount of airflow required for safe operation is not compromised.

Mechanical Loading

Equipment should be mounted into a rack so that a hazardous condition does not arise due to uneven mechanical loading.

Circuit Overloading

Consideration should be given to the connection of the equipment to the power supply circuitry and the effect that any possible overloading of circuits might have on overcurrent protection and power supply wiring. Appropriate consideration of equipment nameplate ratings should be used when addressing this concern.

Reliable Ground

A reliable ground must be maintained at all times. To ensure this, the rack itself should be grounded. Particular attention should be given to power supply connections other than the direct connections to the branch circuit (i.e. the use of power strips, etc.).

RMC 7132

1U Rackmount System

2-4 Installing the System into a Rack

This section provides information on installing the Acnodes RMC7132 into a rack unit. If the system has already been mounted into a rack, you can skip ahead to Sections 2-5 and 2-6. There are a variety of rack units on the market, which may mean the assembly procedure will differ slightly. The following is a guideline for installing the unit into a rack with the rack rails provided with the system. You should also refer to the installation instructions that came with the rack unit you are using.

Identifying the Sections of the Rack Rails

You should have received two rack rail assemblies with the Acnodes RMC7132. Each of these assemblies consist of two sections: an inner fixed chassis rail that secures to the unit (A) and an outer fixed rack rail (B) that secures to the rail brackets. A sliding rail guide sandwiched between the two should remain attached to the fixed rack rail (see Figure 2-1). The A and B rails must be detached from each other to install.

To remove the fixed chassis rail (A), pull it out as far as possible - you should hear a "click" sound as a locking tab emerges from inside the rail assembly and locks the inner rail. Then depress the locking tab to pull the inner rail completely out. Do this for both the left and right side rack rail assemblies.

Figure 2-1. Identifying the Sections of the Rack Rails

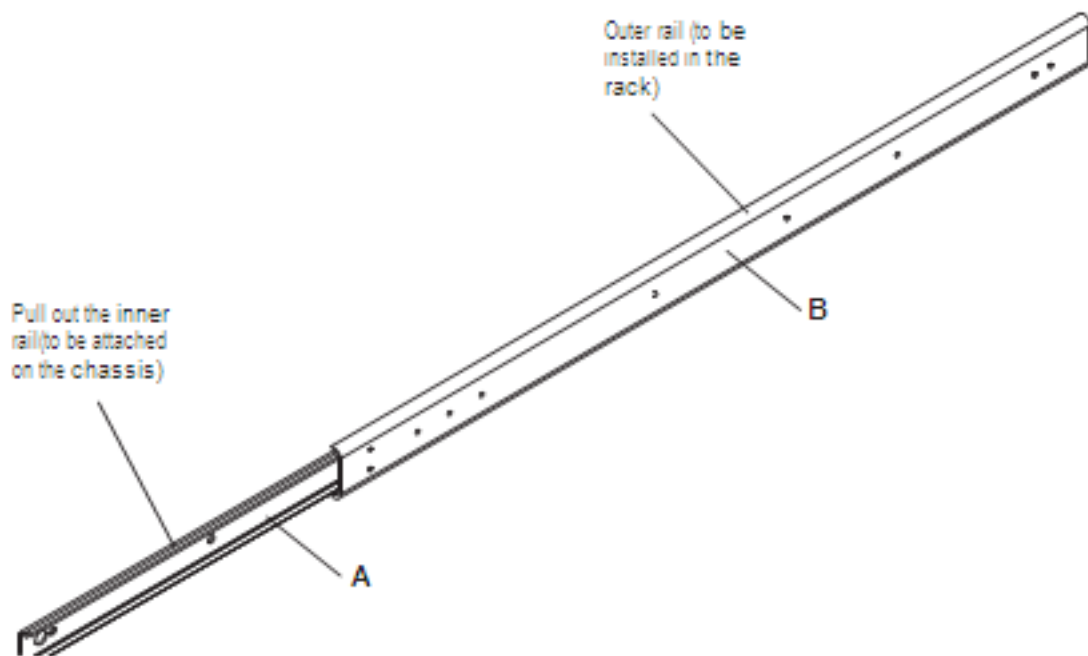

RMC 7132

1U Rackmount System

Installing the Chassis Rails

Position the fixed chassis rail sections you just removed along the side of the chassis making sure the five screw holes line up. Note that these two rails are left/right specific. Screw the rail securely to the side of the chassis (see Figure 2-2). Repeat this procedure for the other rail on the other side of the chassis. You will also need to attach the rail brackets when installing into a telco rack.

Locking Tabs: As you have seen, both chassis rails have a locking tab, which serves two functions. The first is to lock the server into place when installed and pushed fully into the rack, which is its normal position. Secondly, these tabs also lock the server in place when fully extended from the rack. This prevents the server from coming completely out of the rack when you pull it out for servicing.

Figure 2-2. Installing Chassis Rails

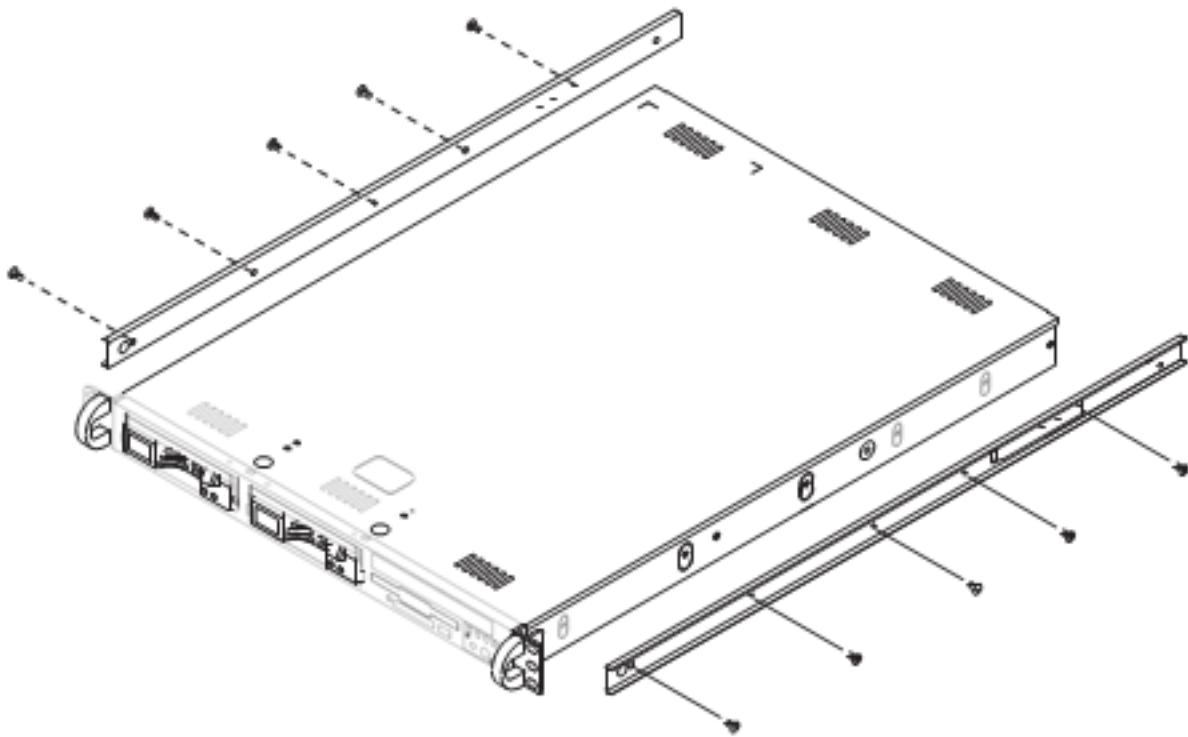

Installing the Rack Rails

Determine where you want to place the server in the rack (see Rack and Server Precautions in Section 2-3). Position the fixed rack rail/sliding rail guide assemblies at the desired location in the rack, keeping the sliding rail guide facing the inside of the rack. Screw the assembly securely to the rack using the brackets provided. Attach the other assembly to the other side of the rack, making sure that both are at the exact same height and with the rail guides facing inward.

ACNODES

661 Brea Canyon Rd., Suite 3
Walnut, CA 91789
tel: 909.598.7388, fax: 909.598.0218

© Copyright 2009 Acnodes, Inc.
All rights reserved. Product description and product specifications
are subject to change without notice. For latest product information,
please visit Acnodes' web site at www.acnodes.com.

RMC 7132

1U Rackmount System

Installing the Server into the Rack

You should now have rails attached to both the chassis and the rack unit. The next step is to install the server into the rack. Do this by lining up the rear of the chassis rails with the front of the rack rails. Slide the chassis rails into the rack rails, keeping the pressure even on both sides (you may have to depress the locking tabs when inserting). See Figure 2-3.

When the server has been pushed completely into the rack, you should hear the locking tabs "click".

Figure 2-3. Installing the Server into a Rack

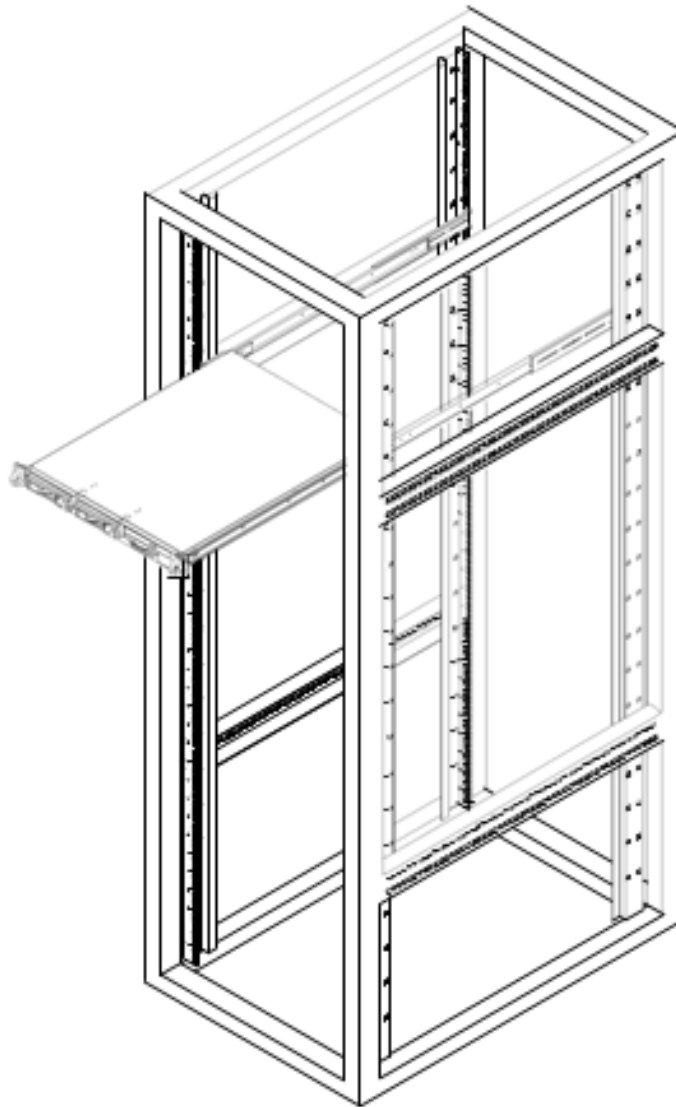

RMC 7132

1U Rackmount System

Installing the Server into a Telco Rack

If you are installing the Acnodes RMC7132 into a Telco type rack, follow the directions given on the previous pages for rack installation. The only difference in the installation procedure will be the positioning of the rack brackets to the rack. They should be spaced apart just enough to accommodate the width of the telco rack.

Figure 2-4. Installing the Server into a Telco Rack

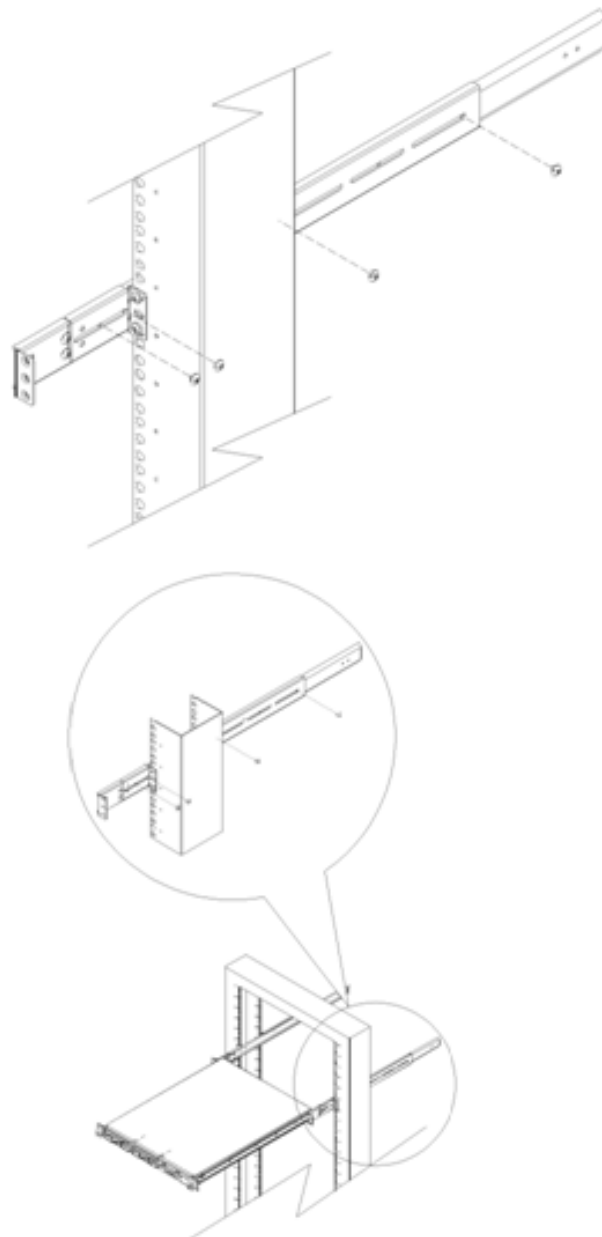

ACNODES

661 Brea Canyon Rd., Suite 3
Walnut, CA 91789
tel: 909.598.7388, fax: 909.598.0218

© Copyright 2009 Acnodes, Inc.
All rights reserved. Product description and product specifications
are subject to change without notice. For latest product information,
please visit Acnodes' web site at www.acnodes.com.

The image shows a blue-tinted photograph of a server rackmount unit. The unit is a 1U rackmount system, as indicated by the text. The background of the image is a dark blue with a lighter blue curved shape on the right side. The text 'RMC 7132' and '1U Rackmount System' is overlaid on the right side of the image.

RMC 7132

1U Rackmount System

2-5 Checking the Motherboard Setup

After you install the RMC7132 in the rack, you will need to open the unit to make sure the serverboard is properly installed and all the connections have been made.

Accessing the Inside of the System (Figure 2-5)

1. First, grasp the two handles on either side and pull the unit straight out until it locks (you will hear a "click").
2. Next, depress the two buttons on the top of the chassis to release the top cover. There is a large rectangular recess in the middle front of the top cover to help you push the cover away from you until it stops.
3. You can then lift the top cover from the chassis to gain full access to the inside of the server.

Checking the Components

1. You may have one or two processors already installed into the system board. Each processor should have its own heatsink attached. See Chapter 5 for instructions on processor and heatsink installation.
2. Your RMC7132 server system may have come with system memory already installed. Make sure all DIMMs are fully seated in their slots. For details on adding system memory, refer to Chapter 5.
3. If desired, you can install an add-on card to the system. See Chapter 5 for details on installing a PCI add-on card.
4. Make sure all power and data cables are properly connected and not blocking the airflow. See Chapter 5 for details on cable connections.
5. Check the air seals for damage. The air seals are located under the blower fan and beneath the frame cross section that separates the drive bay area from the serverboard area of the chassis.

RMC 7132

1U Rackmount System

Figure 2-5. Accessing the Inside of the System

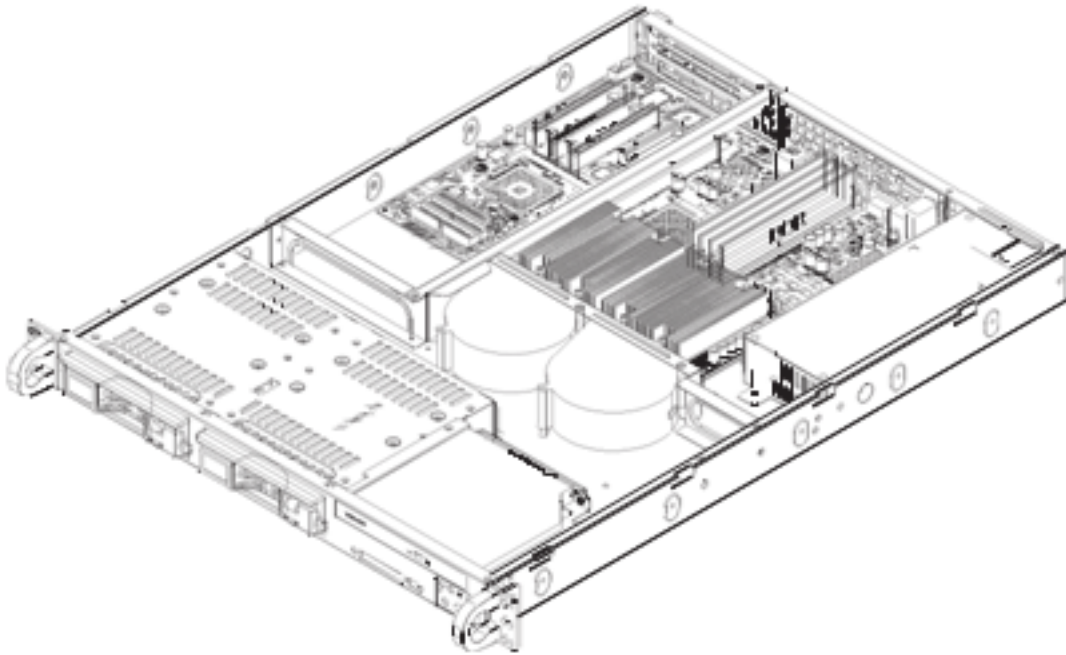

2-6 Checking the Drive Bay Setup

Next, you should check to make sure the peripheral drives and the Serial ATA drives and Serial ATA backplane have been properly installed and all essential connections have been made.

Checking the Drives

1. All drives can be accessed from the front of the server. For servicing the DVD-ROM and floppy drives, you will need to remove the top chassis cover.
2. Refer to Chapter 6 if you need to reinstall a DVD-ROM and/or floppy disk drive to the system.
3. Depending upon your system's configuration, your system may have one or two Serial ATA drives already installed. If you need to install Serial ATA drives, please refer to the appropriate section in Chapter 6.

Checking the Airflow

1. Airflow is provided by two 10-cm input fans. The system component layout was carefully designed to promote sufficient airflow through the small 1U rackmount space.
2. Note that all power and data cables have been routed in such a way that they do not block the airflow generated by the fans.

Providing Power

1. The last thing you must do is to provide input power to the system. Plug the power cord from the power supply unit into a high-quality power strip that offers protection from electrical noise and power surges. It is recommended that you use an uninterruptible power supply (UPS).
2. Finish by depressing the power button on the chassis control panel.

CHAPTER 3 SYSTEM INTERFACE

3-1 Overview

There are several LEDs on the control panel to keep you constantly informed of the overall status of the system as well as the activity and health of specific components. There are also two buttons on the control panel. This chapter explains the meanings of all LED indicators and the appropriate response you may need to take.

3-2 Control Panel Buttons

There are two push buttons located on the front of the chassis: a reset button and a power on/off button.



Reset Button

The reset button reboots the system.



Power

This is the main power button, which is used to apply or turn off the main system power. Turning off system power with this button removes the main power but keeps standby power supplied to the system. If you need to service the system you should unplug the AC power cord after shutting down the server.

3-3 Control Panel LEDs

The control panel located on the front of the chassis has five LEDs. These LEDs provide you with critical information related to different parts of the system. This section explains what each LED indicates when illuminated and any corrective action you may need to take.

RMC 7132

1U Rackmount System



Overheat

When this LED is on it indicates an overheat condition, which may be caused by cables obstructing the airflow in the system or the ambient room temperature being too warm. Check the routing of the cables and make sure all fans are present and operating normally. You should also check to make sure that the chassis covers are installed. Finally, verify that the heatsinks are installed properly (see Chapter 5). This LED will remain on as long as the indicated condition exists.



NIC2

Indicates network activity on LAN2 when flashing .



NIC1

Indicates network activity on LAN1 when flashing.



HDD

Channel activity for all HDDs. This light indicates IDE or SATA drive activity when flashing.

RMC 7132

1U Rackmount System



Power

Indicates power is being supplied to the system's power supply units. This LED should normally be illuminated when the system is operating.

3-4 Serial ATA Drive Carrier LEDs

Each Serial ATA drive has both a green and a red LED.

- o **Green:** Each Serial ATA drive carrier has a green LED. When illuminated, this green LED (on the front of the SATA drive carrier) indicates drive activity. A connection to the SATA backplane enables this LED to blink on and off when that particular drive is being accessed. Please refer to Chapter 6 for instructions on replacing failed SATA drives.

- o **Red:** The red LED to indicate an SATA drive failure. If one of the SATA drives fail, you should be notified by your system management software. Please refer to Chapter 6 for instructions on replacing failed SATA drives.

CHAPTER 4 SYSTEM SAFETY

4-1 Electrical Safety Precautions



Basic electrical safety precautions should be followed to protect yourself from harm and the Acnodes RMC7132 from damage:

- o Be aware of the locations of the power on/off switch on the chassis as well as the room's emergency power-off switch, disconnection switch or electrical outlet. If an electrical accident occurs, you can then quickly remove power from the system.
- o Do not work alone when working with high voltage components.
- o Power should always be disconnected from the system when removing or installing main system components, such as the motherboard, memory modules and floppy drive. When disconnecting power, you should first power down the system with the operating system first and then unplug the power cords of all the power supply units in the system.
- o When working around exposed electrical circuits, another person who is familiar with the power-off controls should be nearby to switch off the power if necessary.
- o Use only one hand when working with powered-on electrical equipment. This is to avoid making a complete circuit, which will cause electrical shock. Use extreme caution when using metal tools, which can easily damage any electrical components or circuit boards they come into contact with.
- o Do not use mats designed to decrease static electrical discharge as protection from electrical shock. Instead, use rubber mats that have been specifically designed as electrical insulators.
- o The power supply power cords must include a grounding plug and must be plugged into grounded electrical outlets.

RMC 7132

1U Rackmount System

- o Motherboard Battery: CAUTION - There is a danger of explosion if the onboard battery is installed upside down, which will reverse its polarities (see Figure 4-1). This battery must be replaced only with the same or an equivalent type recommended by the manufacturer. Dispose of used batteries according to the manufacturer's instructions.
- o DVD-ROM Laser: CAUTION - this server may have come equipped with a DVD-ROM drive. To prevent direct exposure to the laser beam and hazardous radiation exposure, do not open the enclosure or use the unit in any unconventional way.
- o Mainboard replaceable soldered-in fuses: Self-resetting PTC (Positive Temperature Coefficient) fuses on the mainboard must be replaced by trained service technicians only. The new fuse must be the same or equivalent as the one replaced. Contact technical support for details and support.

4-2 General Safety Precautions



Follow these rules to ensure general safety:

- o Keep the area around the RMC7132 clean and free of clutter.
- o The RMC7132 weighs approximately 10 lbs (4.5 kg). When lifting the system, two people at either end should lift slowly with their feet spread out to distribute the weight. Always keep your back straight and lift with your legs.
- o Place the chassis top cover and any system components that have been removed away from the system or on a table so that they won't accidentally be stepped on.
- o While working on the system, do not wear loose clothing such as neckties and unbuttoned shirt sleeves, which can come into contact with electrical circuits or be pulled into a cooling fan.
- o Remove any jewelry or metal objects from your body, which are excellent metal conductors that can create short circuits and harm you if they come into contact with printed circuit boards or areas where power is present.

RMC 7132

1U Rackmount System

o After accessing the inside of the system, close the system back up and secure it to the rack unit with the retention screws after ensuring that all connections have been made.

4-3 ESD Precautions



Electrostatic Discharge (ESD) is generated by two objects with different electrical charges coming into contact with each other. An electrical discharge is created to neutralize this difference, which can damage electronic components and printed circuit boards. The following measures are generally sufficient to neutralize this difference before contact is made to protect your equipment from ESD:

- o Use a grounded wrist strap designed to prevent static discharge.
- o Keep all components and printed circuit boards (PCBs) in their antistatic bags until ready for use.
- o Touch a grounded metal object before removing the board from the antistatic bag.
- o Do not let components or PCBs come into contact with your clothing, which may retain a charge even if you are wearing a wrist strap.
- o Handle a board by its edges only; do not touch its components, peripheral chips, memory modules or contacts.
- o When handling chips or modules, avoid touching their pins.
- o Put the motherboard and peripherals back into their antistatic bags when not in use.
- o For grounding purposes, make sure your computer chassis provides excellent conductivity between the power supply, the case, the mounting fasteners and the motherboard.

RMC 7132

1U Rackmount System

4-4 Operating Precautions



Care must be taken to assure that the chassis cover is in place when the RMC7132 is operating to assure proper cooling. Out of warranty damage to the system can occur if this practice is not strictly followed.

Figure 4-1. Installing the Onboard Battery



Please handle used batteries carefully. Do not damage the battery in any way; a damaged battery may release hazardous materials into the environment. Do not discard a used battery in the garbage or a public landfill. Please comply with the regulations set up by your local hazardous waste management agency to dispose of your used battery properly.

CHAPTER 5

ADVANCED MOTHERBOARD SETUP

This chapter covers the steps required to install the embedded board into the chassis, connect the data and power cables and install add-on cards. All motherboard jumpers and connections are also described. A layout and quick reference chart are included in this chapter for your reference. Remember to completely close the chassis when you have finished working with the motherboard to better cool and protect the system.

5-1 Handling the Motherboard

Electrostatic Discharge (ESD) can damage electronic components. To prevent damage to any printed circuit boards (PCBs), it is important to handle them very carefully (see previous chapter). To prevent the motherboard from bending, keep one hand under the center of the board to support it when handling. The following measures are generally sufficient to protect your equipment from electric static discharge.

Precautions

- o Use a grounded wrist strap designed to prevent Electrostatic Discharge (ESD).
- o Touch a grounded metal object before removing any board from its antistatic bag.
- o Handle a board by its edges only; do not touch its components, peripheral chips, memory modules or gold contacts.
- o When handling chips or modules, avoid touching their pins.
- o Put the motherboard, add-on cards and peripherals back into their antistatic bags when not in use.
- o For grounding purposes, make sure your computer chassis provides excellent conductivity between the power supply, the case, the mounting fasteners and the motherboard.



RMC 7132

1U Rackmount System

Unpacking

The motherboard is shipped in antistatic packaging to avoid electrical static discharge. When unpacking the board, make sure the person handling it is static protected.

5-2 Serverboard Installation

This section explains the first step of physically mounting the embedded board into the RMC7132 chassis. Following the steps in the order given will eliminate the most common problems encountered in such an installation. To remove the motherboard, follow the procedure in reverse order.

Installing to the Chassis

1. Access the inside of the system by removing the screws from the back lip of the top cover of the chassis, then pull the cover off.
2. The embedded board requires a chassis big enough to support a 12" x 9.6" serverboard.
3. Make sure that the I/O ports on the serverboard align properly with their respective holes in the I/O shield at the back of the chassis.
4. Carefully mount the serverboard to the serverboard tray by aligning the board holes with the raised metal standoffs that are visible in the chassis.
5. Insert screws into all the mounting holes on your serverboard that line up with the standoffs and tighten until snug (if you screw them in too tight, you might strip the threads). Metal screws provide an electrical contact to the serverboard ground to provide a continuous ground for the system.
6. Finish by replacing the top cover of the chassis.

Warning: To avoid damaging the motherboard and its components, do not apply any force greater than 8 lbs. per square inch when installing a screw into a mounting hole.



RMC 7132

1U Rackmount System

5-3 Connecting Cables

Now that the motherboard is installed, the next step is to connect the cables to the board. These include the data cables for the peripherals and control panel and the power cables.

Connecting Data Cables

The cables used to transfer data from the peripheral devices have been carefully routed to prevent them from blocking the flow of cooling air that moves through the system from front to back. If you need to disconnect any of these cables, you should take care to keep them routed as they were originally after reconnecting them (make sure the red wires connect to the pin 1 locations). The following data cables (with their locations noted) should be connected. (See the motherboard layout for connector locations.)

- o Control Panel cable (JF1)
- o COM Port cable (COM2)
- o Front USB port cable (USB2/3)
- o SATA drive data cables (SATA0 ~ SATA1)

Important! Make sure the the cables do not come into contact with the fans.

Connecting Power Cables

The embedded board has a 24-pin primary power supply connector (JPW1) for connection to the ATX power supply. In addition, there is an 8-pin processor power connector (JPW2) that must be connected to your power supply. See Section 5-9 for power connector pin definitions.

Connecting the Control Panel

JF1 contains header pins for various front control panel connectors. See Figure 5-1 for the pin locations of the various front control panel buttons and LED indicators.

All JF1 wires have been bundled into a single cable to simplify this connection. Make sure the red wire plugs into pin 1 as marked on the board. The other end connects to the Control Panel PCB board, located just behind the system status LEDs on the chassis. See Chapter 5 for details and pin descriptions.

RMC 7132

1U Rackmount System

Figure 5-1. Control Panel Header Pins

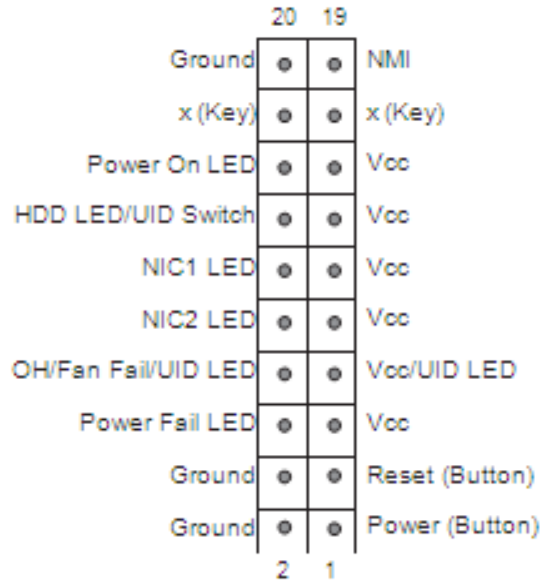

5-4 I/O Ports

The I/O ports are color coded in conformance with the PC 99 specification. See Figure 5-2 below for the colors and locations of the various I/O ports.

Figure 5-2. I/O Ports

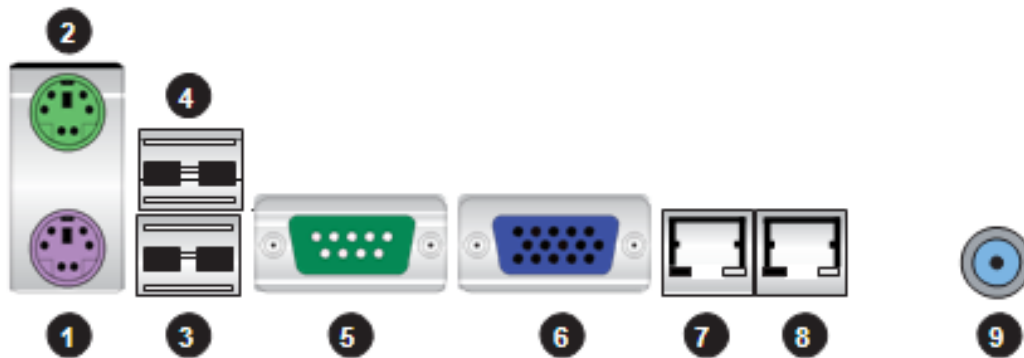

Rear I/O Ports	
1. Keyboard	b. VGA Port
2. PS/2 Mouse	7. LAN1
3. USB0	8. LAN2
4. USB1	9. UID Button
5. COM1	+3.3V

RMC 7132

1U Rackmount System

5-5 Installing the Processor and Heatsink



When handling the processor package, avoid placing direct pressure on the label area of the fan.

Notes:

1. Always connect the power cord last and always remove it before adding, removing or changing any hardware components. Make sure that you install the processor into the CPU socket before you install the CPU heatsink.
2. Intel's boxed processor package contains the CPU fan and heatsink assembly. If you buy a CPU separately, make sure that you use an Intel-certified multi-directional heatsink and fan only.
3. Make sure to install the motherboard into the chassis before you install the CPU heatsink and heatsink fan.
4. When purchasing an LGA1366 processor or when receiving a motherboard with an LGA1366 processor pre-installed, make sure that the plastic CPU cap is in place and none of the CPU pins are bent; otherwise, contact your retailer immediately.
5. Refer to the Supermicro web site for more details on supported CPUs.

Installing an LGA1366 Processor

1. Press the socket clip to release the load plate, which covers the CPU socket, from its locked position.
2. Gently lift the socket clip to open the load plate.
3. Hold the plastic cap at its north and south center edges to remove it from the CPU socket.

Note: The photos on this page and succeeding pages are for illustration purposes only. They do not necessarily reflect the exact product(s) described in this manual.

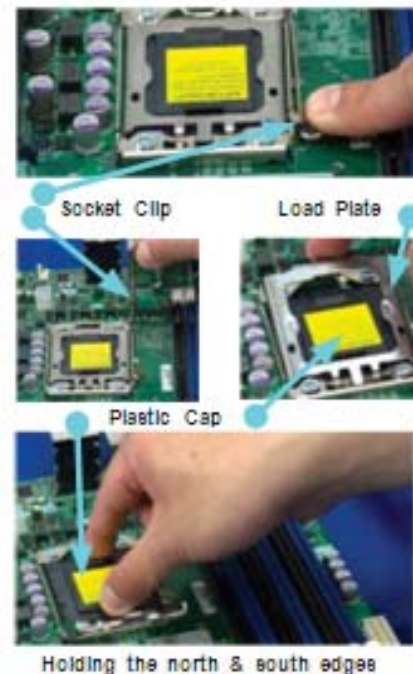

RMC 7132

1U Rackmount System

1. After removing the plastic cap, use your thumb and the index finger to hold the CPU at the north and south center edges.

2. Align the CPU key (the semi-circle cutout) with the socket key (the notch below the gold color dot on the side of the socket).

3. Once the CPU and the socket are aligned, carefully lower the CPU straight down into the socket.

Do not rub the CPU against the surface of the socket or its pins to avoid damaging the CPU or the socket.

4. With the CPU in the socket, inspect the four corners of the CPU to make sure that it sits level and is properly installed.

5. Once the CPU is securely seated in the socket, lower the CPU load plate to the socket.

6. Use your thumb to gently push the socket clip down to the clip lock.

Important! Please save the plastic cap. The motherboard must be shipped with the plastic cap properly installed to protect the CPU socket pins. Shipment without the plastic cap properly installed may cause damage to the socket pins.

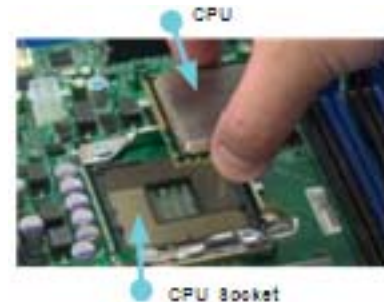

RMC 7132

1U Rackmount System

Installing a Passive CPU Heatsink

Notes: The motherboard comes with a heatsink bracket pre-installed on the reverse side of the board. Do not apply any thermal grease to the heatsink or the CPU die; the required amount has already been applied.

1. Place the heatsink on top of the CPU so that the four mounting holes are aligned with those on the retention mechanism.
2. Install two diagonal screws (i.e. the #1 and the #2 screws) and tighten them until just snug (do not fully tighten the screws to avoid damaging the CPU.)
3. Repeat step 2 with the #3 and #4 screws. Make sure all screws are snug.

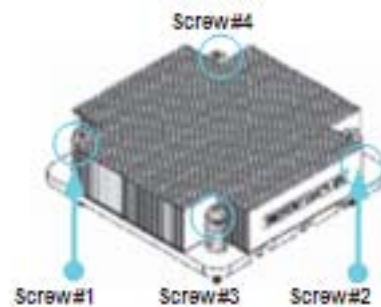

RMC 7132

1U Rackmount System

Removing the Heatsink



Warning: We do not recommend that the CPU or the heatsink be removed. However, if you do need to remove the heatsink, please follow the instructions below prevent damage to the CPU or other components.

1. Power down the system and unplug the power cord from the power supply.
2. Disconnect the heatsink fan's wires from the fan header.
3. Using a screwdriver, loosen and remove the heatsink screws from the motherboard in the sequence as show in the previ- ous section (#1 and #2 followed by #3 and #4.
4. Hold the heatsink as shown in the picture on the right and gently wiggle it to loosen it from the CPU. (Do not use excessive force when doing this.)
5. Once the heatsink is loose, remove it from the CPU socket.
6. To reinstall the heatsink, clean the surface of the CPU and the heatsink to get rid of the old thermal grease. Reapply the proper amount of thermal grease to the surface of the CPU then reinstall the heatsink.

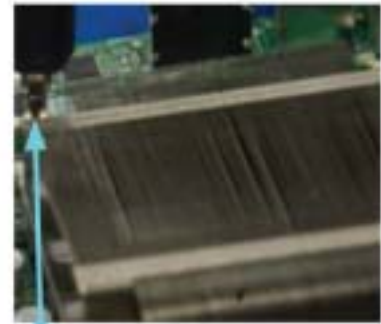

Screw#1



Screw#2



RMC 7132

1U Rackmount System

5-6 Installing Memory Modules

Note: Check the Supermicro web site for recommended memory modules.

CAUTION

Exercise extreme care when installing or removing DIMM modules to prevent any possible damage.

Installing & Removing DIMMs

1. Insert the desired number of DIMMs into the memory slots, starting with DIMM #1A. For best performance, please use the memory modules of the same type and same speed in the same bank. See the DIMM Installation Chart on the following page. 2. Press down the release tabs on the ends of a memory slot. Insert each DIMM module vertically into its slot. Pay attention to the notch along the bottom of the module to prevent inserting the DIMM module incorrectly.
3. Gently press down on the DIMM module until it snaps into place in the slot. Repeat for all modules.
4. Reverse the steps above to remove the DIMM modules from the motherboard.

Press down the release tabs



Insert & press down a DIMM module into the slot



Figure 5-3. DIMM Installation

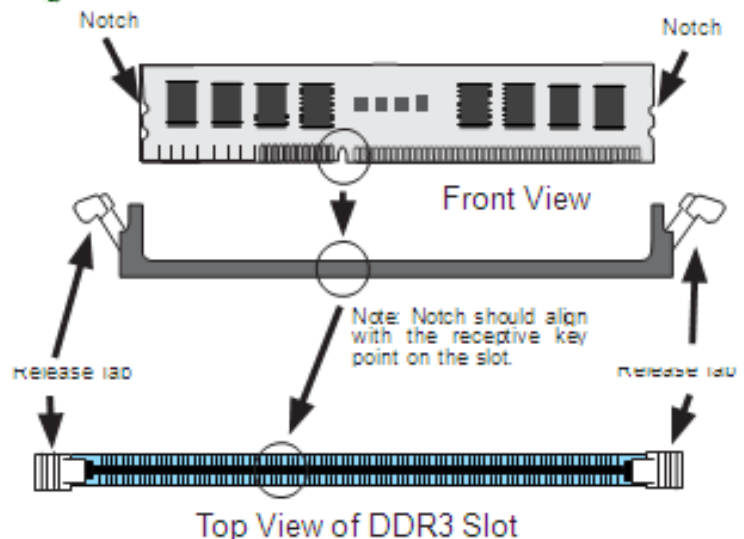

To Install:

Insert module vertically and press down until it snaps into place. Pay attention to the alignment notch at the bottom.

To Remove:

Use your thumbs to gently push the release tabs near both ends of the module. This should release it from the slot.

RMC 7132

1U Rackmount System

Memory Support

The RMC7132 supports up to 24 GB of unbuffered ECC or non-ECC DDR3 1333/1066/800 in 6 DIMM slots. Populating the DIMM slots with a pair (or pairs) of memory modules of the same type and size will result in interleaved memory, which will improve memory performance.

Populating DIMMs

For memory to work properly, follow the table below for memory installation:

Memory Population (UDIMM Only Routing)				
DIMM Slots per Channel	DIMMs Populated per Channel	DIMM Type	POR Speeds (in MHz)	Ranks per DIMM (any combination; SR=Single Rank, DR=Dual Rank)
2	1	Unbuffered DDR3 (with or without ECC)	800,1066,1333	SR, DR
2	2	Unbuffered DDR3 (with or without ECC)	800,1066,	SR, DR

Population Rules: Any combination of x8 and x16 UDIMMs, with 1Gb or 2Gb DRAM density.

Memory Population (UDIMM 3 DIMMs per Channel Routing)				
DIMM Slots per Channel	DIMMs Populated per Channel	DIMM Type	POR Speeds (in MHz)	Ranks per DIMM (any combination; SR=Single Rank, DR=Dual Rank)
3	1	Unbuffered DDR3 (with or without ECC)	800,1066,1333	SR, DR
3	2	Unbuffered DDR3 (with or without ECC)	800,1066,	SR, DR

Population Rules: Any combination of x8 UDIMMs, with 1Gb or 2Gb DRAM density.

Maximum Memory Possible

Single Rank UDIMMs - 12GB (6x 2GB DIMMs), Dual Rank UDIMMs - 24GB (6x 4GB DIMMs)

o Both unbuffered ECC and non-ECC DIMM modules are supported by the motherboard. Using ECC or non-ECC memory on your motherboard depends on the CPU installed.

o Due to OS limitations, some operating systems may not show more than 4 GB of memory.

o Due to memory allocation to system devices, the amount of memory that remains available for operational use will be reduced when 4 GB of RAM is used. The reduction in memory availability is disproportional. Refer to the table below.

RMC 7132

1U Rackmount System

Possible System Memory Allocation & Availability		
System Device	Size	Physical Memory Remaining (4 GB Total System Memory)
Firmware Hub flash memory (System BIOS)	1 MB	3.99
Local APIC	4 KB	3.99
Area Reserved for the chipset	2 MB	3.99
I/O APIC (4 Kbytes)	4 KB	3.99
PCI Enumeration Area 1	256 MB	3.76
PCI Express (256 MB)	256 MB	3.51
PCI Enumeration Area 2 (if needed) -Aligned on 256-MB boundary-	512 MB	3.01
VGA Memory	16 MB	2.85
TSEG	1 MB	2.84
Memory available to System BIOS & OS applications		2.84

5-7 PCI Expansion Cards

The RMC7132 chassis uses a riser card to accommodate one add-on card (CSE- RR1U-E16 for a PCI-E x16 card).

Installing a PCI Expansion Card

1. After powering down the system, remove the PCI slot shield.
2. Fully seat the riser card into the slot, pushing down with your thumbs evenly on both sides of the card.
3. Install the expansion card into the riser card.
4. Finish by using a screw to secure the top of the card shield to the chassis.
5. The PCI slot shield protects the serverboard and its components from EMI and aid in proper ventilation, so make sure it is always in place.

RMC 7132

1U Rackmount System

5-8 Serverboard Details

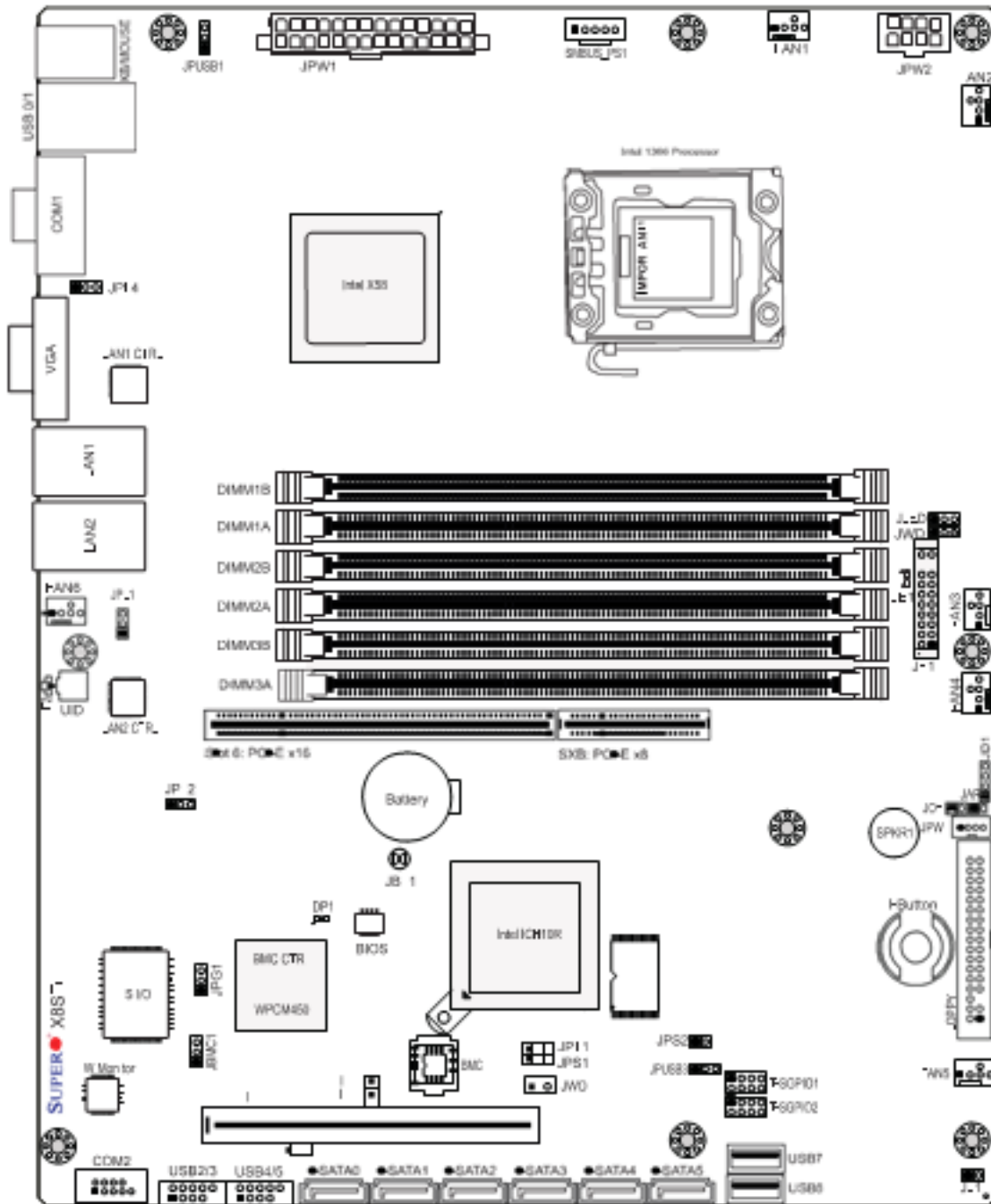

Notes

Jumpers not indicated are for testing purposes only.

RMC 7132

1U Rackmount System

Quick Reference

Jumper	Description	Default Setting
JBMC1	BMC Enable/Disable	Pins 1-2 (Enabled)
JBT1	CMOS Clear	(See Section 5-10)
JPC1/JPC2	SMB to PCI Slots	Closed (Disabled)
JPG1	VGA Enable/Disable	Pins 1-2 (Enabled)
JPL1/JPL2	LAN 1/2 Enable/Disable	Pins 1-2 (Enabled)
JPUSB1	USB0/1 Wake-up	Pins 1-2 (Enabled)
JPUSB2	FP USB 2/3, 4/5 Wake-up	Pins 1-2 (Enabled)
JPUSB3	FP USB 6, 7 Wake-up	Pins 1-2 (Enabled)
JWD	Watch Dog Timer Enable	Pins 1-2 (Reset)

Connector	Description
COM1/COM2	COM1/COM2 Serial Port/Header
FAN 1-6	Chassis/CPU Fan Headers
Floppy	Floppy Disk Drive Connector
I-Button	I-Button Socket (for RAID 5 support)
I-SATA0, I-SATA5	SATA Ports
JAR	Alarm Reset Header
JD1	Speaker Header
JF1	Front Panel Connector
JL1	Chassis Intrusion Header
JLED	Power LED Header
JOH	Overheat LED Header
JPW1	24-pin Main ATX Power Connector
JPW2	+12V 8-pin CPU Power Connector
JPWF	Power Supply Fail LED Header
JWOL	Wake-On-LAN Header
LAN1/2	Gigabit Ethernet (RJ45) Ports
SMB_PS1	PWR supply (IPC) System Management Bus
T-SGPIO-0, T-SGPIO-1	Serial General Purpose Input/Output Headers
UID	Unit Identifier Button
USB0/1	Universal Serial Bus (USB) Ports
USB2/3, USB4/5/6/7	Onboard USB Ports, Headers

See section 5-11 for descriptions of the onboard LEDs.

RMC 7132

1U Rackmount System

5-9 Connector Definitions

Main ATX Power Supply Connector

The 24-pin primary power supply connector (JPW1) meets the SSI EPS 12V specification. The 8 - pin CPU PWR connector (JPW2) is also required for the processor. Refer to the table on the right for the pin definitions.

ATX Power 24-pin Connector Pin Definitions (JPW1)			
Pin#	Definition	Pin #	Definition
13	+3.3V	1	+3.3V
14	-12V	2	+3.3V
15	COM	3	COM
16	PS_ON	4	+5V
17	COM	5	COM
18	COM	6	+5V
19	COM	7	COM
20	Res (NC)	8	PWR_OK
21	+5V	9	5VSB
22	+5V	10	+12V
23	+5V	11	+12V
24	COM	12	+3.3V

Processor Power Connector

JPW2 must also be connected to the power supply to provide power for the processor. See the table on the right for pin definitions.

+12V 8-pin Power Pin Definitions (JPW2)	
Pins	Definition
1 - 4	Ground
5 - 8	+12V

Required Connection

Power Button

The power button (from the computer chassis) connects to pins 1 and 2 of JF1. See the table on the right for pin definitions.

Power Button Pin Definitions (JF1)	
Pin#	Definition
1	Power Signal
2	Ground

Reset Button

The reset button (from the computer chassis) connects to pins 3 and 4 of JF1. See the table on the right for pin definitions.

Reset Button Pin Definitions (JF1)	
Pin#	Definition
3	Reset
4	Ground

Power Fail LED

The Power Fail LED connection is located on pins 5 and 6 of JF1. Refer to the table on the right for pin definitions.

PWR Fail LED Pin Definitions (JF1)	
Pin#	Definition
5	Vcc
6	Ground

RMC 7132

1U Rackmount System

Overheat/Fan Fail/UID LED

Connect an LED to pins 7 and 8 of JF1 to provide UID signals and advanced warning of chassis overheating. Refer to the table on the right for pin definitions.

OH/Fan Fail/UID LED Pin Definitions (JF1)		OH/Fan Fail Indicator Status	
Pin#	Definition	State	Definition
7	Vcc/UID LED	Off	Normal
8	OH/Fan Fail LED	On	Overheat
		Flashing	Fan Fail

NIC2 (LAN2) LED

The LED connections for LAN2 are on pins 9 and 10 of JF1. Attach an LED cable to display network activity. See the table on the right for pin definitions.

NIC2 LED Pin Definitions (JF1)	
Pin#	Definition
9	Vcc
10	Ground

NIC1 (LAN1) LED

The LED connections for LAN1 are on pins 11 and 12 of JF1. Attach an LED cable to display network activity. See the table on the right for pin definitions.

NIC1 LED Pin Definitions (JF1)	
Pin#	Definition
11	Vcc
12	Ground

HDD LED/UID Switch

The HDD LED and UID switch connections are located on pins 13 and 14 of JF1. Attach a cable here to indicate HDD activity or UID (Unit Identification) status. See the table on the right for pin definitions.

HDD LED Pin Definitions (JF1)	
Pin#	Definition
13	Vcc
14	HD Active

Power On LED

The Power On LED connector is located on pins 15 and 16 of JF1 (use JLED for a 3-pin connector). This connection is used to provide LED indication of power being supplied to the system. See the table on the right for pin definitions.

Power LED Pin Definitions (JF1)	
Pin#	Definition
15	5V Stby
16	Control

RMC 7132

1U Rackmount System

NMI Button

The non-maskable interrupt button header is located on pins 19 and 20 of JF1. Refer to the table on the right for pin definitions.

NMI Button Pin Definitions (JF1)	
Pin#	Definition
19	Control
20	Ground

Fan Headers

There are six fan headers on the serverboard, all of which are 4-pin fans (pins 1-3 are backward compatible with traditional 3-pin fans). See the table on the right for pin definitions. The onboard fan speeds are controlled by Thermal Management (via Hardware Monitoring) under the Advanced Section in the BIOS. The default is disabled. Please use all 3-pin fans or all 4-pin fans.

Fan Header Pin Definitions (FAN1-6)	
Pin#	Definition
1	Ground (Black)
2	2.5A/+15V (Red)
3	Tachometer
4	PWM Control

ATX PS/2 Keyboard and PS/2 Mouse Ports

The ATX PS/2 keyboard and the PS/2 mouse are located beside the USB0/1 ports. The mouse port is above the keyboard port. See the table on the right for pin definitions.

PS/2 Keyboard and Mouse Port Pin Definitions	
Pin#	Definition
1	Data
2	NC
3	Ground
4	VCC
5	Clock
6	NC

Serial Ports

Two serial ports are included on the serverboard. COM1 is a backpanel port and COM2 is a header located on the corner of the board near USB2. See the table on the right for pin definitions.

Serial Port Pin Definitions (COM1/COM2)			
Pin#	Definition	Pin#	Definition
1	DCD	6	DSR
2	RXD	7	RTS
3	TXD	8	CTS
4	DTR	9	RI
5	Ground	10	NC

RMC 7132

1U Rackmount System

Chassis Intrusion

The Chassis Intrusion header is designated JL1. Attach an appropriate cable from the chassis to inform you of a chassis intrusion when the chassis is opened

Chassis Intrusion Pin Definitions (JL1)	
Pin#	Definition
1	Intrusion Input
2	Ground

Wake-On-LAN

The Wake-On-LAN header is designated JWOL on the serverboard. See the table on the right for pin definitions. You must also have a LAN card with a Wake-On-LAN connector and cable to use this feature.

Wake-On-LAN Pin Definitions (JWOL)	
Pin#	Definition
1	+5V Standby
2	Ground
3	Wake-up

External Speaker/Internal Buzzer

On the JD1 header, pins 1-4 are for an external speaker and pins 3-4 are for the internal speaker. If you wish to use an external speaker, connect it to pins 1-4 to. If you wish to use the onboard speaker, you should close pins 3-4 with a jumper.

Speaker Connector (JD1)	
Pin Setting	Definition
Pins 3-4	Internal Speaker
Pins 1-4	External Speaker

Overheat/Fan Fail LED

The JOH can be connected to an LED to provide warning of chassis overheat. This LED will also blink to indicate a fan failure. Refer to the table on the right for pin definitions.

Overheat LED Pin Definitions (JOH)	
Pin#	Definition
1	5VDC
2	OH Active

OH/Fan Fail LED Status Indications	
State	Indication
Solid	Overheat
Blinking	Fan Fail

Onboard Power LED

An onboard Power LED header is located at JLED. This header connects to the control panel header (JF1) to indicate the status of system power. See the table on the right for pin definitions.

Onboard PWR LED Pin Definitions (JLED)	
Pin#	Definition
1	VCC
2	No Connection
3	Connection to PWR LED in JF1

RMC 7132

1U Rackmount System

Universal Serial Bus (USB)

There are two Universal Serial Bus ports located on the I/O panel. An additional six USB headers are included on the board, which may be used for front side access (cables not included). USB 6 and USB 7 are "Type A" connectors. See the table on the right for pin definitions.

Universal Serial Bus Pin Definitions (USB)			
USB0/1		USB4/5/6/7	
Pin #	Definition	Pin #	Definition
1	+5V	1	+5V
2	PO-	2	PO-
3	PO+	3	PO+
4	Ground	4	Ground
5	N/A	5	Key

SGPIO Headers

The SGPIO (Serial General Purpose Input/Output) headers are used to communicate with an enclosure management chip on the backplane. The T-SGPIO headers are for SATA and the 3-SGPIO headers (X8STi only) are for SAS configurations. See the table on the right for pin definitions.

SGPIO Header Pin Definitions (T-SGPIO-0/ T-SGPIO-1, 3-TGPIO-0/3-SGPIO-1)			
Pin#	Definition	Pin	Definition
1	NC	2	NC
3	Ground	4	DATA Out
5	Load	6	Ground
7	Clock	8	NC

NC = No Connection

Power Supply SMBus Header

A Power SMB header is located at SMB_PS1. Connect the appropriate cable here to utilize SMB on your system. See the table on the right for pin definitions.

Power Supply SMB Header Pin Definitions (SMB_PS1)	
Pin#	Definition
1	Clock
2	Data
3	PWR Fall
4	Ground
5	+3.3V

LAN1/2 (Ethernet Ports)

The Ethernet ports (LAN1 and LAN2, plus LAN3 and LAN4 on the X8STi- LN4) are located beside the VGA port on the I/O backplane. These ports accept RJ45 type cables.



RMC 7132

1U Rackmount System

Power Supply Fail LED Header

Connect a cable from your power supply to JPWF to provide a warning of power supply failure. This warning signal is passed through the PWR_LED pin to indicate of a power failure on the chassis. See the table on the right for pin definitions.

PWR Supply Fail LED Pin Definitions (JPWF)	
Pin#	Definition
1	PWR 1 Fail
2	PWR 2 Fail
3	PWR 3 Fail
4	Signal: Alarm Reset

Note: This feature is only available when using Supermicro redundant power supplies.

Alarm Reset

If three power supply modules are installed, the system can notify you when any of the three fails. Connect JAR to a micro-switch to enable you to turn off the alarm that is activated when a power module fails. See the table on the right for pin definitions.

Alarm Reset Pin Definitions (JAR)	
Pin Setting	Definition
Pin 1	Ground
Pin 2	Alarm Reset

Note: This feature is only available when using Supermicro redundant power supplies.

I-Button

The I-Button, located near the floppy connector, is a computer chip enclosed in a durable stainless container to enable RAID 5 under Software RAID mode. See the table on the right for pin definitions.

I-Button Pin Definitions	
Pin#	Definition
1	Ground
2	GPIO1
3	Ground

Unit Identifier Button

SW1 is a Unit Identifier (UID) button and is located next to FAN6. There is another UID button located on the control panel. When you push either UID button, both Rear UID and Front Panel UID Indicators will illuminate. Push either button again to turn off both indicators. These UID indicators provide easy identification of a system unit that may be in need of service.

UID Button Pin Definitions	
Pin#	Definition
1	Ground
2	Ground
3	Button In
4	Ground

RMC 7132

1U Rackmount System

5-10 Jumper Settings

Explanation of Jumpers

To modify the operation of the mother-board, jumpers can be used to choose between optional settings. Jumpers create shorts between two pins to change the function of the connector. Pin 1 is identified with a square solder pad on the printed circuit board. See the motherboard layout pages for jumper locations. Note: On a two-pin jumper, "Closed" means the jumper is on both pins and "Open" means the jumper is either on only one pin or completely removed.

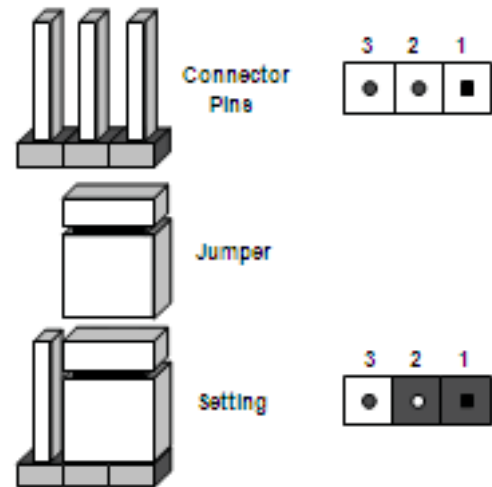

CMOS Clear

JBT1 is used to clear CMOS (which will also clear any passwords). Instead of pins, this jumper consists of contact pads to prevent accidentally clearing the contents of CMOS.

To clear CMOS,

1. First power down the system and unplug the power cord(s).
2. With the power disconnected, short the CMOS pads with a metal object such as a small screwdriver.
3. Remove the screwdriver (or shorting device).
4. Reconnect the power cord(s) and power on the system.

Note: Do not use the PW_ON connector to clear CMOS.

VGA Enable/Disable

JPG1 allows you to enable or disable the VGA port. The default position is on pins 1 and 2 to enable VGA. See the table on the right for jumper settings.

VGA Enable/Disable Jumper Settings (JPG1)	
Jumper Setting	Definition
Pins 1-2	Enabled
Pins 2-3	Disabled

RMC 7132

1U Rackmount System

LAN1/2 Enable/Disable

Change the setting of jumper JPL1 and JPL2 to enable or disable the LAN1 and LAN2 Ethernet ports, respectively. See the table on the right for jumper settings. The default setting is enabled.

LAN1/2 En/Disable Jumper Settings (JPL1/JPL2)	
Jumper Setting	Definition
Pins 1-2	Enabled
Pins 2-3	Disabled

Watch Dog Enable/Disable

JWD controls the Watch Dog function. Watch Dog is a system monitor that can reboot the system when a software application hangs. Jumping pins 1-2 will cause WD to reset the system if an application hangs. Jumping pins 2-3 will generate a non-maskable interrupt signal for the application that hangs. See the table on the right for jumper settings. Watch Dog must also be enabled in BIOS.

Note: When enabled, the user needs to write their own application software in order to disable the Watch Dog Timer.

Watch Dog Jumper Settings (JWD)	
Jumper Setting	Definition
Pins 1-2	Reset
Pins 2-3	NMI
Open	Disabled

USB Wake-Up

These three jumpers allow you to wake up the system by pressing a key on the USB keyboard or by clicking the USB mouse of your system. The jumpers are used together with the USB Wake-Up feature in BIOS and both must be enabled to use this feature. See the table on the right for jumper settings.

Note: The default setting is enabled. Please be sure to remove all other USB devices from the USB ports whose USB jumpers are set to disabled before the system goes into standby mode.

USB Wake-Up Jumper Settings (JUSB1, JUSB2, JUSB3)	
Jumper Setting	Definition
Pins 1-2	Enabled
Pins 2-3	Disabled

Note: JUSB1 is for USB ports #0/1, JUSB2 is for USB2/3 and 4/5 and JUSB3 is for USB 6 and 7.

RMC 7132

1U Rackmount System

SMBus to PCI Slots

Jumpers JI2C1 and JI2C2 allow you to connect the System Management Bus (I2C) to the PCI slot. The default setting is Open (Disabled.) Both jumpers must be set to the same setting (JI2C1 controls the clock and JI2C2 controls the data). See the table on the right for jumper settings.

SMBus to PCI Slots Jumper Settings (JI2C1/JI2C2)		
Jumper Setting	Definition	
JI2C1: Closed	JI2C2: Closed	Enabled
JI2C1: Open	JI2C2: Open	Disabled

BMC Enable/Disable

The JBMC1 jumper allows the user to enable or disable the BMC (Base-board Management Control) chip and the onboard IPMI connections. This jumper is to be used together with the IPMI settings in the BIOS. If this jumper is set to enabled, please also enable IPMI in the BIOS and vice versa. The default position is on pins 1 and 2 to enable BMC. See the table on the right for jumper settings.

BMC Enable/Disable Jumper Settings (JBMC1)	
Settings	Definition
Pins 1-2	Enabled
Pins 2-3	Disabled

Note: the BMC jumper should be left on pins 1-2 - it is recommended you do not change this setting.

5-11 Onboard Indicators

LAN1/2 LEDs

The Ethernet ports (located beside the VGA port) have two LEDs. On each port, one LED indicates activity while the other LED may be green, amber or off to indicate the speed of the connection. See the table on the right for the indication associated with the connection speed LED.

LAN1/2 LED (Connection Speed Indicator)	
LED Color	Definition
Off	NC or 10 Mb/s
Green	100 Mb/s
Amber	1 Gb/s



RMC 7132

1U Rackmount System

Onboard Power LED (LE1)

An Onboard Power LED is located at LE1 on the motherboard. When LE1 is on, the AC power cable is connected. Make sure to disconnect the power cable before removing or installing any component. See the table on the right for more details.

Onboard Power LED Indicator (LE1)	
LED Color	Definition
Off	System Off (power cable not connected)
Green	System on or power cable connected

UID LED

The Unit Identifier LED is designated LE2 on the motherboard. This LED illuminates to easily identify the system in a rack full of servers.

BMC Heartbeat LED

DP1 is a BMC (Baseboard Management Controller) Heartbeat LED. When DP1 blinks, the BMC is functioning properly.

RMC 7132

1U Rackmount System

5-12 Floppy and SATA and SAS Ports

Floppy Drive Connector

The floppy connector is located near the USB2 port and the I-Button. See the table at right for pin definitions.

Floppy Drive Connector Pin Definitions (Floppy)			
Pin#	Definition	Pin #	Definition
1	Ground	2	FOHDIN
3	Ground	4	Reserved
5	Key	6	FOEDIN
7	Ground	8	Index
9	Ground	10	Motor Enable
11	Ground	12	Drive Select B
13	Ground	14	Drive Select B
15	Ground	16	Motor Enable
17	Ground	18	DIR
19	Ground	20	STEP
21	Ground	22	Write Data
23	Ground	24	Write Gate
25	Ground	26	Track 00
27	Ground	28	Write Protect
29	Ground	30	Read Data
31	Ground	32	Slide 1 Select
33	Ground	34	Reserved

SATA Ports

There are no jumpers to configure the onboard SATA ports. See the table on the right for pin definitions.

SATA Port Pin Definitions (I-SATA0 - I-SATA5)			
Pin#	Definition	Pin #	Definition
1	Ground	2	TXP
3	TXN	4	Ground
5	RXN	6	RXP
7	Ground		

RMC 7132

1U Rackmount System

5-13 Installing Software

After the hardware has been installed, you should first install the operating system and then the drivers. The necessary drivers are all included on the CDs that came packaged with your motherboard.



Driver/Tool Installation Display Screen

Note: Click the icons showing a hand writing on paper to view the readme files for each item. Click the computer icons to the right of these items to install each item (from top to the bottom) one at a time. After installing each item, you must re-boot the system before moving on to the next item on the list. The bottom icon with a CD on it allows you to view the entire contents of the CD.

RMC 7132

1U Rackmount System

Doctor III

The Doctor III program is a Web based management tool that supports remote management capability. It includes Remote and Local Management tools. The local management is called SD III Client. The Doctor III program included on the CD-ROM that came with your motherboard allows you to monitor the environment and operations of your system. Doctor III displays crucial system information such as CPU temperature, system voltages and fan status. See the Figure below for a display of the Supero Doctor III interface.

Note: The default User Name and Password for Doctor III is ADMIN / ADMIN.

Note: When Doctor III is first installed, it adopts the temperature threshold settings that have been set in BIOS. Any subsequent changes to these thresholds must be made within Doctor, as the Doctor settings override the BIOS settings. To set the BIOS temperature threshold settings again, you would first need to uninstall Doctor III.

Doctor III Interface Display Screen (Health Information)

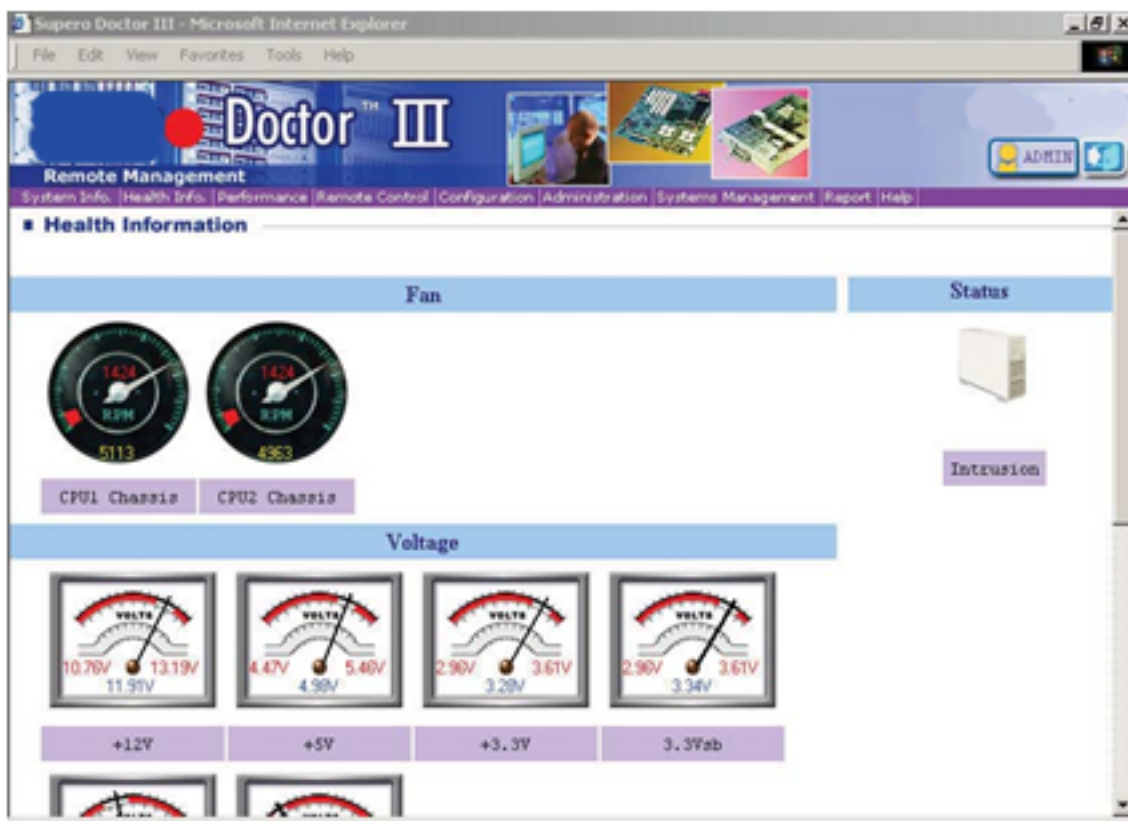

RMC 7132

1U Rackmount System

Doctor III Interface Display Screen (Remote Control)



CHAPTER 6 ADVANCED CHASSIS SETUP

This chapter covers the steps required to install components and perform maintenance on the SC512C-250 chassis. For component installation, follow the steps in the order given to eliminate the most common problems encountered. If a step is unnecessary, skip ahead to the step that follows.

Tools Required

The only tool you will need to install components and perform maintenance is a Philips screwdriver.

6-1 Static-Sensitive Devices

Electrostatic Discharge (ESD) can damage electronic components. To prevent damage to any printed circuit boards (PCBs), it is important to handle them very carefully. The following measures are generally sufficient to protect your equipment from ESD discharge.

Precautions

- o Use a grounded wrist strap designed to prevent static discharge.
- o Touch a grounded metal object before removing any board from its antistatic bag.
- o Handle a board by its edges only; do not touch its components, peripheral chips, memory modules or gold contacts.
- o When handling chips or modules, avoid touching their pins.
- o Put the serverboard, add-on cards and peripherals back into their antistatic bags when not in use.
- o For grounding purposes, make sure your computer chassis provides excellent conductivity between the power supply, the case, the mounting fasteners and the serverboard.

RMC 7132

1U Rackmount System

Figure 6-1. Chassis Front View



Figure 6-2. Chassis Rear View

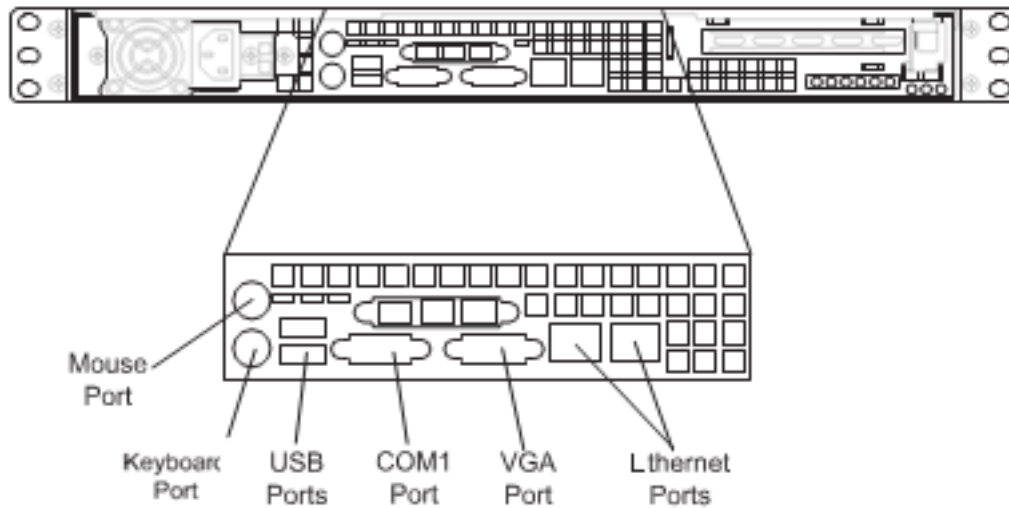

6-2 Control Panel

The control panel (located on the front of the chassis) must be connected to the JF1 connector on the serverboard to provide you with system control buttons and status indicators. These wires have been bundled together in a ribbon cable to simplify the connection.

Connect the cable from JF1 on the serverboard to the Control Panel PCB (printed circuit board). Make sure the red wire plugs into pin 1 on both connectors. Pull all excess cabling out of the airflow path. The LEDs inform you of system status. See Chapter 3 for details on the LEDs and the control panel buttons. Details on JF1 can be found in Chapter 5.



RMC 7132

1U Rackmount System

6-3 System Fans

Two 10-cm blower fans provide the cooling for the Acnodes RMC7132. The chassis includes air seals under the blower fans and at the chassis cross section, which separates the drive bay area from the serverboard area of the chassis to promote better airflow. It is highly important that the air seal is properly installed and making a good seal in order for the cooling air to circulate properly through the chassis.

The fans can adjust their speed according to the heat level sensed in the system, which results in more efficient and quieter fan operation. Fan speed is controlled by a setting in BIOS (see Chapter 7).

System Fan Failure

If a fan fails, the ambient air temperature in the chassis will rise and activate the overheat LED on the control panel. You will need to power down the system to replace this fan with one of the same type (p/n FAN-0038L4). Contact your vendor or Supermicro for information on replacement fans.

Replacing System Cooling Fans

1. Turn off the power to the system and remove the AC power cord.
2. Remove the chassis cover and unplug the fan cable from the serverboard
3. Unscrew the failed blower fan from the chassis and pull it completely out from the serverboard.
4. Replace the failed fan with an identical 10-cm, 12 volt fan. Position the new fan in its proper place and secure it to the chassis with the screws you removed previously.
5. After the new fan has been installed, plug the fan cable back into the same chassis fan header on the serverboard you removed it from.
6. Reconnect the AC power cord and power up the system.
7. Check that the fan is working properly and that the overheat LED on the control panel has turned off.
8. Finish by replacing the top panel of the chassis.

RMC 7132

1U Rackmount System

6-4 Drive Bay Installation/Removal

Accessing the Drive Bays

Serial ATA Drives: Because of their hot-swap capability, you do not need to access the inside of the chassis or power down the system to install or replace Serial ATA drives. Proceed to the next step for instructions.

DVD-ROM Drive: For installing/removing a DVD-ROM drive, you'll need to gain access to the inside of the R,C7132 by removing the top cover of the chassis. Proceed to the "DVD-ROM Drive Installation" section later in this chapter for instructions.

Note: Only a "slim" DVD-ROM drive will fit into the RMC7132.

SATA Drive Installation

The SATA drives are mounted in drive carriers to simplify their installation and removal from the chassis. These carriers also help promote proper airflow for the Serial ATA drive bays. For this reason, even empty carriers without Serial ATA drives installed must remain in the chassis.

The SATA drives are hot-swappable, meaning they can be installed and removed without powering down the system

Figure 6-3. Mounting a Drive in a Carrier

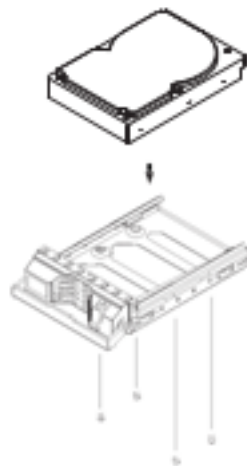

RMC 7132

1U Rackmount System

Mounting a SATA Drive in a Drive Carrier

1. Install a drive into the carrier with the printed circuit board side toward the carrier so that the Mounting holes align with those in the carrier.
2. Secure the drive to the carrier with four screws, as shown in Figure 6-3.

Installing/Removing SATA Drives

1. To remove, first push the release button located beside the drive LEDs
2. Swing the colored handle fully out and use it to pull the unit straight out (see Figure 6-4).
3. To install, simply push the drive carrier into its bay until fully seated.

Figure 6-4. Removing/Installing SATA Drives

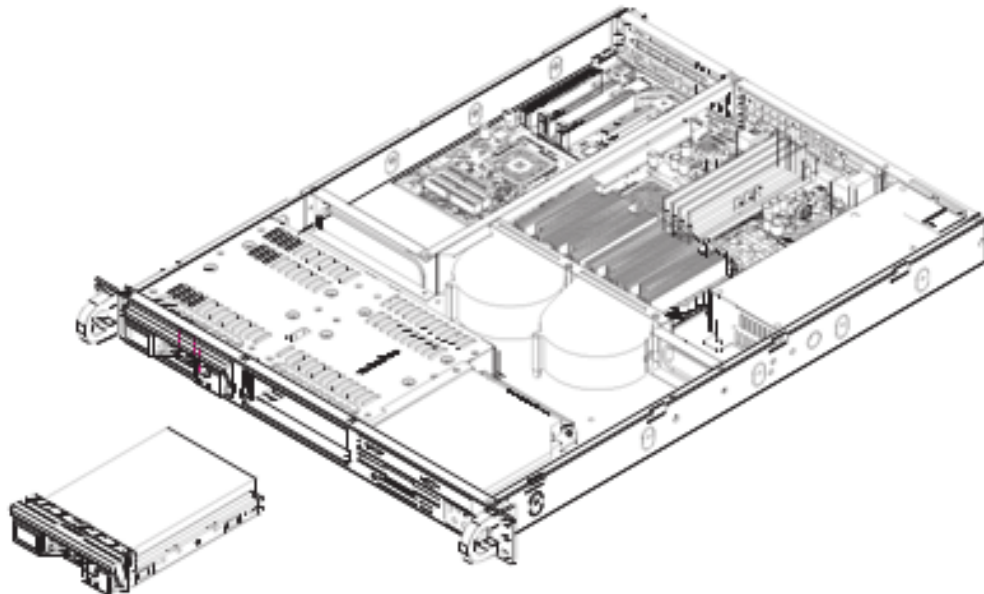

Important: Regardless of how many SATA drives are installed, both drive carriers must remain in the drive bays to maintain proper airflow.



Use caution when working around the SATA backplane. Do not touch the backplane with any metal objects and make sure no ribbon cables touch the backplane or obstruct the holes, which aid in proper airflow.



RMC 7132

1U Rackmount System

SATA Power Cables

SATA power cables should be routed so that they do not block the airflow through the chassis. See the serverboard layout diagram for the location of the cable connections.

DVD-ROM Drive Installation

The top cover of the chassis must be opened to gain full access to the DVD-ROM drive bay. The DVD-ROM drive must have a "slim" profile to fit into the RMC7132.

Installing a DVD-ROM Drive

1. Turn off the power to the system and remove the AC power cord.
2. Release the retention screws that secure the unit to the rack.
3. Grasp the two handles on either side and pull the unit straight out until it locks (you will hear a "click").
4. Depress the two buttons on the top of the chassis to release the top cover and at the same time, push the cover away from you until it stops.
5. Lift the top cover from the chassis to gain full access to the inside of the server.
6. Disconnect the power and data cables from the drive to other chassis components including the motherboard and backplane.
7. Remove the old drive by depressing the release tab, then pulling the drive out of the chassis.
8. Insert the new drive unit in the slot until the tab locks into place.
9. Connect the data and power cables to the backplane and motherboard.
10. Replace the chassis cover, reconnect the AC power cord and power up the system.



RMC 7132

1U Rackmount System

6-5 Power Supply

The Acnodes RMC7132 has a single 200 watt power supply. This power supply has the capability of operating at 100 - 240 input volts. Power down the system and then unplug the AC power cord to completely remove power from the system before removing the power supply.

Power Supply Failure

If the power supply unit fails, the system will shut down and you will need to replace the power supply unit. Replacement units can be ordered directly from Acnodes(PWS-201-1H - see contact information in Chapter 1).

Replacing the Power Supply

1. Power down the system (if on) and unplug the power cord.
2. Grasp the two handles on either side and pull the unit straight out until it locks (you will hear a "click").
3. Depress the two buttons on the top of the chassis to release the top cover and push it away from you. You can then lift the top cover from the chassis to gain full access to the inside of the server.
4. To remove the failed power unit, remove the two screws on the back of the power supply and a third from the front of the power supply, which secures it to the bottom of the chassis. You can then lift the unit straight out of the chassis.
5. Replace the failed unit with another unit of the same wattage. It is highly recommended to replace it with the exact same power supply.
6. Carefully insert the new unit into position in the chassis and secure it with the two screws at the rear of the unit and the third at the front.
7. Reconnect the power cord, replace the chassis top cover and push the unit back into the rack.
8. Finish by depressing the power button on the front of the system

CHAPTER 7 BIOS

7-1 Introduction

This chapter describes the AMI BIOS Setup Utility for the RMC7132. The AMI ROM BIOS is stored in a Flash EEPROM and can be easily updated. This chapter describes the basic navigation of the AMI BIOS Setup Utility setup screens.

Starting BIOS Setup Utility

To enter the AMI BIOS Setup Utility screens, press the <Delete> key while the system is booting up.

Note: In most cases, the <Delete> key is used to invoke the AMI BIOS setup screen. There are a few cases when other keys are used, such as <F1>, <F2>, etc.

Each main BIOS menu option is described in this manual. The Main BIOS setup menu screen has two main frames. The left frame displays all the options that can be configured. Grayed-out options cannot be configured. Options in blue can be configured by the user. The right frame displays the key legend. Above the key legend is an area reserved for a text message. When an option is selected in the left frame, it is highlighted in white. Often a text message will accompany it. (Note: the AMI BIOS has default text messages built in. Supermicro retains the option to include, omit, or change any of these text messages.)

The AMI BIOS Setup Utility uses a key-based navigation system called hot keys. Most of the AMI BIOS setup utility hot keys can be used at any time during the setup navigation process. These keys include <F1>, <F10>, <Enter>, <ESC>, arrow keys, etc.

Note: Options printed in Bold are default settings.

How To Change the Configuration Data

The configuration data that determines the system parameters may be changed by entering the AMI BIOS Setup utility. This Setup utility can be accessed by pressing during system boot.

RMC 7132

1U Rackmount System

Starting the Setup Utility

Normally, the only visible POST (Power On Self Test) routine is the memory test. As the memory is being tested, press the <Delete> key to enter the main menu of the AMI BIOS Setup Utility. From the main menu, you can access the other setup screens. An AMI BIOS identification string is displayed at the left bottom corner of the screen, below the copyright message.



Warning!! Do not upgrade the BIOS unless your system has a BIOS-related issue. Flashing the wrong BIOS can cause irreparable damage to the system. In no event shall Supermicro be liable for direct, indirect, special, incidental, or consequential damages arising from a BIOS update. If you have to update the BIOS, do not shut down or reset the system while the BIOS is updating. This is to avoid possible boot failure.

7-2 Main Setup

When you first enter the AMI BIOS Setup Utility, you will enter the Main setup screen. You can always return to the Main setup screen by selecting the Main tab on the top of the screen. The Main BIOS Setup screen is shown below.



RMC 7132

1U Rackmount System

System Overview: The following BIOS information will be displayed:

System Time/System Date

Use this option to change the system time and date. Highlight System Time or System Date using the arrow keys. Enter new values through the keyboard. Press the

<Tab> key or the arrow keys to move between fields. The date must be entered in Day MM/DD/YY format. The time is entered in HH:MM:SS format. (Note: The time is in the 24-hour format. For example, 5:30 P.M. appears as 17:30:00.)

AMIBIOS Version Build Date

Processor

The AMI BIOS will automatically display the status of processor as shown below: Type of Processor

Speed

Physical Count

Logical Count

System Memory

This displays the size of memory available in the system: Populated Size

Available Size

RMC 7132

1U Rackmount System

7-3 Advanced Setup Configurations

Use the arrow keys to select Boot Setup and hit <Enter> to access the submenu items:

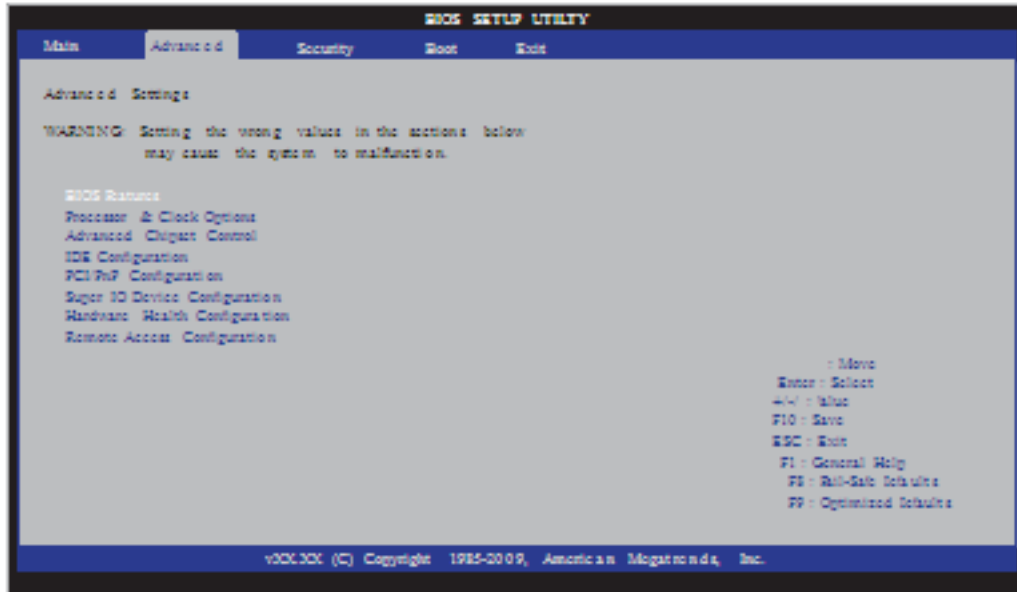

XBIOS Features

Quick Boot

If Enabled, this option will skip certain tests during POST to reduce the time needed for system boot. The options are Enabled and Disabled.

Quiet Boot

This option allows the bootup screen options to be modified between POST messages or the OEM logo. Select Disabled to display the POST messages. Select Enabled to display the OEM logo instead of the normal POST messages. The options are Enabled and Disabled.

AddOn ROM Display Mode

This sets the display mode for Option ROM. The options are Force BIOS and Keep Current.

Bootup Num-Lock

This feature selects the Power-on state for Numlock key. The options are Off and On.



RMC 7132

1U Rackmount System

PS/2 Mouse Support

This feature enables support for the PS/2 mouse. The options are Disabled, Enabled and Auto.

Wait For 'F1' If Error

This forces the system to wait until the 'F1' key is pressed if an error occurs. The options are Disabled and Enabled.

Hit 'Del' Message Display

This feature displays "Press DEL to run Setup" during POST. The options are Enabled and Disabled.

Watch Dog Function

If enabled, the Watch Dog Timer will allow the system to reboot when it is inactive for more than 5 minutes. The options are Enabled and Disabled.

Power Button Function

This setting allows you to decide if the power button will turn off the system instantly or wait for 4 seconds when it is pressed. The options are Instant Off and 4 Seconds Override.

Restore on AC Power Loss

Use this feature to set the power state after a power outage. Select Power-Off for the system power to remain off after a power loss. Select Power-On for the system power to be turned on after a power loss. Select Last State to allow the system to resume its last state before a power loss. The options are Power-On, Power-Off and Last State.

Interrupt 19 Capture

Interrupt 19 is the software interrupt that handles the boot disk function. When this item is set to Enabled, the ROM BIOS of the host adaptors will "capture" Interrupt

19 at boot and allow the drives that are attached to these host adaptors to function as bootable disks. If this item is set to Disabled, the ROM BIOS of the host adaptors will not capture Interrupt 19, and the drives attached to these adaptors will not function as bootable devices. The options are Enabled and Disabled.



RMC 7132

1U Rackmount System

XProcessor & Clock Options



Warning: Take Caution when changing the Advanced settings. An incorrect value, a very high DRAM frequency or incorrect DRAM timing may cause system to become unstable. When this occurs, revert to the default setting.

CPU Ratio

This feature allows the user to use the CPU clock multiplier to multiply CPU speed in order to enhance performance. Select Manual to Manually set the multiplier setting. Select Auto for the BIOS to automatically select the CPU multiplier setting for your system. The options are Auto and Manual.

Ratio CMOS Setting

This option allows the user to set the ratio between the CPU Core Clock and the FSB Frequency. (Note: if an invalid ratio is entered, the AMI BIOS will restore the setting to the previous state.) The default setting depends on the type of CPU is installed. The default setting for the Intel® Core i7™ 965 is [24].

Clock Spread Spectrum

Select Enable to use the feature of Clock Spectrum, which will allow the BIOS to monitor and attempt to reduce the level of Electromagnetic Interference caused by the components whenever needed. Select Disabled to enhance system stability. The options are Disabled and Enabled.

Hardware Prefetcher (Available when supported by the CPU)

If set to Enabled, the hardware pre fetcher will pre fetch streams of data and instructions from the main memory to the L2 cache in the forward or backward manner to improve CPU performance. The options are Disabled and Enabled.

Adjacent Cache Line Prefetch (Available when supported by the CPU)

The CPU fetches the cache line for 64 bytes if this option is set to Disabled. The CPU fetches both cache lines for 128 bytes as comprised if Enabled.



RMC 7132

1U Rackmount System

Intel® Virtualization Technology (Available when supported by the CPU)

Select Enabled to use the feature of Virtualization Technology to allow one platform to run multiple operating systems and applications in independent partitions, creating multiple "virtual" systems in one physical computer. The options are Enabled and Disabled. Note: If there is any change to this setting, you will need to power off and restart the system for the change to take effect. Please refer to Intel's web site for detailed information.

Execute-Disable Bit Capability (Available when supported by the OS and the CPU)

Set to Enabled to enable the Execute Disable Bit which will allow the processor to designate areas in the system memory where an application code can execute and where it cannot, thus preventing a worm or a virus from flooding illegal codes to overwhelm the processor or damage the system during an attack. The default is Enabled. (Refer to Intel and Microsoft Web Sites for more information.)

Simultaneous Multi-Threading (Available when supported by the CPU)

Set to Enabled to use the Hyper-Threading Technology, which will result in increased CPU performance. The options are Disabled and Enabled. **Active Processor Cores**

Set to Enabled to use a processor's Second Core and beyond. (Please refer to Intel's web site for more information.) The options are All, 1 and 2.

Intel® EIST Technology

EIST (Enhanced Intel SpeedStep Technology) allows the system to automatically adjust processor voltage and core frequency in an effort to reduce power consumption and heat dissipation. Please refer to Intel's web site for detailed information.

The options are Disable: Disable GV3 and Enable: Enable GV3.

Intel® TurboMode Tech (Available if Intel® EIST technology is Enabled)

This feature allows processor cores to run faster than marked frequency in specific conditions. The options are Disabled and Enabled.



RMC 7132

1U Rackmount System

Intel Turbo Boost Configuration

Turbo Ratio Limit Program

Select Enabled to set the processor's clock ratio in relation to the bus speed. The options are Enabled and Disabled. The default value depends on the type of CPU installed. (For example, the values shown below indicate that an Intel® Core™ i7 processor 965 Extreme Edition is installed.)

1 - Core Ratio Limit

This increases (multiplies) the processor's core 1 clock speed in relation to the bus speed. The default setting is 26. Press "+" or "-" on your keyboard to change this value.

2 ~ 3 - Core Ratio Limit

This increases the processor's core 2~3 clock speeds in relation to the bus speed. The default setting is 25. Press "+" or "-" on your keyboard to change this value.

TDC Limit Override

This option will override the system's default electrical current setting for the processor. The options are Enabled and Disabled.

TDC Limit Value

This option sets the processor's electrical current value. The default setting is 880. Press "+" or "-" on your keyboard to change this value.

TDP Limit Override

Select Enabled to override the default power setting for the processor. The options are Enabled and Disabled.

TDP Limit Value

Use this option to set the processor's power value. The default setting is 1040. Press "+" or "-" on your keyboard to change this value.

C1E Support

Select Enabled to use the "Enhanced Halt State" feature. C1E significantly reduces the CPU's power consumption by reducing the CPU's clock cycle and voltage during a "Halt State." The options are Disabled and Enabled.

The header image features a blue background with a glowing, abstract pattern of light blue and white dots and lines, resembling a circuit board or data flow. The text 'RMC 7132' is prominently displayed in white, with '1U Rackmount System' below it in a smaller white font.

RMC 7132

1U Rackmount System

C-STATE Tech

If enabled, C-State is set by the system automatically to either C2, C3 or C4 state. The options are Disabled and Enabled.

C-State package limit setting

If set to Auto, the AMI BIOS will automatically set the limit on the C-State package register. The options are Auto, C1, C3, C6 and C7.

C1 Auto Demotion

When enabled, the CPU will conditionally demote C3, C6 or C7 requests to C1 based on un-core auto-demote information. The options are Disabled and Enabled.

C3 Auto Demotion

When enabled, the CPU will conditionally demote C6 or C7 requests to C3 based on un-core auto-demote information. The options are Disabled and Enabled.

DCA Technology

This feature accelerates the performance of TOE devices. Note: A TOE device is a specialized, dedicated processor that is installed on an add-on card or a network card to handle some or all packet processing of this add-on card. For this motherboard, the TOE device is built inside the ESB 2 South Bridge chip. This feature is supported only by some types of processors (i.e., Intel Nehalem-WS 1S). The options are Enabled and Disabled.

DCA Prefetch Delay

A DCA Prefetch is used with TOE components to prefetch data in order to shorten execution cycles and maximize data processing efficiency. Prefetching too frequently can saturate the cache directory and delay necessary cache accesses. This feature reduces or increases the frequency the system prefetches data. The options are [8], [16], [32], [40], [48], [56], [64], [72], [80], [88], [96], [104], [112], [120]

XAdvanced Chipset Control

The items included in the Advanced Settings submenu are listed below:

QPI Links Speed

Use this feature to select QPI data transfer speed. The options are Slow-mode, and Full Speed.

QPI Frequency

Use this option to set the QPI frequency. The options are Auto, 4.800 GT, 5.866 GT, and 6.400 GT.



661 Brea Canyon Rd., Suite 3
Walnut, CA 91789
tel: 909.598.7388, fax: 909.598.0218

© Copyright 2005 Acnodes, Inc.
All rights reserved. Product description and product specifications
are subject to change without notice. For latest product information,
please visit Acnodes' web site at www.acnodes.com.



RMC 7132

1U Rackmount System

QPI L0s and L1

Select Enabled to lower the QPI power state. L0s and L1 are automatically selected by the motherboard. The options are Disabled and Enabled.

Memory Frequency

Use this option to force the system memory to run at a different frequency than the default frequency. The available options are Auto, Force DDR-800, Force DDR-1066, and Force DDR-1333.

Memory Mode

The options are Independent, Channel Mirror, Lockstep and Sparing. Independent - All DIMMs are available to the operating system.

Channel Mirror - The motherboard maintains two identical copies of all data in memory for redundancy.

Lockstep - The motherboard uses two areas of memory to run the same set of operations in parallel.

Sparing - A preset threshold of correctable errors is used to trigger fail-over. The spare memory is put online and used as active memory in place of the failed memory.

Demand Scrubbing

Demand Scrubbing is a process that allows the North Bridge to correct correctable memory errors found on a memory module. When the CPU or I/O issues a demand- read command, and the read data from memory turns out to be a correctable error, the error is corrected and sent to the requestor (the original source). Memory is updated as well. Select Enabled to use Demand Scrubbing for ECC memory correction. The options are Enabled and Disabled.

Patrol Scrubbing

Patrol Scrubbing is a process that allows the North Bridge to correct correctable memory errors detected on a memory module and send the correction to the requestor (the original source). When this item is set to Enabled, the North Bridge will read and write back one cache line every 16K cycles, if there is no delay caused by internal processing. By using this method, roughly 64 GB of memory behind the North Bridge will be scrubbed every day. The options are Enabled and Disabled.

Throttling - Open Loop

If set to Enabled, Throttling - Open Loop will be activated when the projected memory temperature exceeds a predefined trip-point. This process can effectively improve memory thermal performance. The options are Disabled and Enabled.



RMC 7132

1U Rackmount System

Inlet Temperature

This is the temperature detected at the chassis inlet. Each step is in 0.5oC increment. The default is [070]. Press "+" or "-" on your keyboard to change this value.

Temperature Rise

This item allows the user to define the temperature rise parameter of a memory module to be used to improve memory power management. Each setting is in

0.5oC increments. The default setting is [020]. Press "+" or "-" on your keyboard

to change this value.

Air Flow

This item allows the user to set the desired speed of air flow to the DIMM modules. Each increment is one mm/sec. The default is [1500]. Press "+" or "-" on your keyboard to change this value.

Altitude

This item allows the user to specify the altitude of the location where the computer is used. For Tylersburg-EP platforms, system memory thermal solution is derated up to 900m. To comply with CPU specifications, BIOS will attempt to adjust and correct DIMM velocity based on the altitude where the system is located in order to improve DIMM thermal performance. Altitude is defined as the number of feet above the sea level where the computer is located. The options are Sea Level or Below, 1~300 (above-), 301~600 (above-), 601~900 (above-),

901~1200 (above-), 1201~1500 (above-), 1501~1800 (above-), 1801~2100 (above-), 2101~2400 (above-), 2401~2700 (above-), and 2701~3000 (above-) the sea level.

DIMM Pitch

Use this feature to specify the distance of physical space between each DIMM module. Each step is in 1/1000 of an inch. The default is [400]. Press "+" or "-" on your keyboard to change this value.

High Performance Event Timer

Select Enabled to activate the High Performance Event Timer (HPET) that produces periodic interrupts at a much higher frequency than a Real-time Clock (RTC) does in synchronizing multimedia streams, providing smooth playback and reducing the dependency on other timestamp calculation devices, such as an x86 RDTSC Instruction embedded in the CPU. The High Performance Event Timer is used to replace the 8254 Programmable Interval Timer. The options are Enabled and Disabled.



RMC 7132

1U Rackmount System

Intel VT-d

Select Enabled to enable Intel's Virtualization Technology support for Direct I/O VT-d by reporting the I/O device assignments to VMM through the DMAR ACPI Tables. This feature offers fully-protected I/O resource-sharing across the Intel platforms, providing the user with greater reliability, security and availability in networking and data-sharing. The settings are Enabled and Disabled.

Intel I/OAT

The Intel I/OAT (I/O Acceleration Technology) significantly reduces CPU overhead by leveraging CPU architectural improvements, freeing resources for more other tasks. Available options are Disabled and Enabled.

Active State Power Management

Select Enabled to start Active-State Power Management for signal transactions between L0 and L1 Links on the PCI Express Bus. This maximizes power-saving and transaction speed. The options are Enabled and Disabled.

USB Functions

This feature allows the user to decide the number of onboard USB ports to be enabled. The Options are: Disabled, 2 USB ports, 4 USB ports, 6 USB ports, and 8 USB ports.

USB 2.0 Controller

Select Enabled to activate the onboard USB 2.0 controller. The options are Enabled and Disabled.

Legacy USB Support

Select Enabled to use Legacy USB devices. If this item is set to Auto, Legacy USB support will be automatically enabled if a legacy USB device is installed on the motherboard, and vice versa. The settings are Disabled, Enabled and Auto.



RMC 7132

1U Rackmount System

XIDE / Floppy Configuration

When this submenu is selected, the AMI BIOS automatically detects the presence of the IDE Devices and displays the following items:

Floppy A

This feature allows the user to select the type of floppy drive connected to the system. The options are Disabled, 360KB 5 1/4", 1.2MB 5 1/4", 720KB 3 1/2", 1.44MB 3 1/2" and 2.88MB 3 1/2".

SATA#1 Configuration

If Compatible is selected, it sets SATA#1 to legacy compatibility mode, while selecting Enhanced sets SATA#1 to native SATA mode. The options are Disabled, Compatible, Enhanced.

Configure SATA#1 as

This feature allows the user to select the drive type for SATA#1. The options are IDE, RAID and AHCI.

ICH RAID CodeBase (Available if RAID is selected above)

Select Intel to enable the Intel SATA Host RAID Utility. Select Adaptec to use the Adaptec Host RAID Utility. The options are Intel and Adaptec.

Max Ports on SATA#1 (Available if either RAID or AHCI is enabled under "Configure SATA#1 as" above)

This feature specifies how many ports are active on SATA #1. The options are 4 Ports and 6 Ports.

SATA#2 Configuration (Available if IDE is enabled under "Configure SATA#1 as" above)

Selecting Enhanced will set SATA#2 to native SATA mode. The options are Disabled, Enhanced

IDE Detect Timeout (sec)

Use this feature to set the time-out value for the BIOS to detect the ATA, ATAPI devices installed in the system. The options are 0 (sec), 5, 10, 15, 20, 25, 30, and 35.

Primary IDE Master/Slave, Secondary IDE Master/Slave, Third IDE Master, and Fourth IDE Master

These settings allow the user to set the parameters of Primary IDE Master/Slave, Secondary IDE Master/Slave, Third and Fourth IDE Master slots. Hit <Enter> to





RMC 7132

1U Rackmount System

activate the following submenu screen for detailed options of these items. Set the correct configurations accordingly. The items included in the submenu are:

Type

Select the type of device connected to the system. The options are Not Installed, Auto, CD/DVD and ARMD.

LBA/Large Mode

LBA (Logical Block Addressing) is a method of addressing data on a disk drive. In the LBA mode, the maximum drive capacity is 137 GB. For drive capacities over 137 GB, your system must be equipped with a 48-bit LBA mode addressing. If not, contact your manufacturer or install an ATA/133 IDE controller card that supports 48-bit LBA mode. The options are Disabled and Auto.

Block (Multi-Sector Transfer)

Block Mode boosts the IDE drive performance by increasing the amount of data transferred. Only 512 bytes of data can be transferred per interrupt if Block Mode is not used. Block Mode allows transfers of up to 64 KB per interrupt. Select Disabled to allow data to be transferred from and to the device one sector at a time. Select Auto to allow data transfer from and to the device occur multiple sectors at a time if the device supports it. The options are Auto and Disabled.

PIO Mode

The IDE PIO (Programmable I/O) Mode programs timing cycles between the IDE drive and the programmable IDE controller. As the PIO mode increases, the cycle time decreases. The options are Auto, 0, 1, 2, 3, and 4.

Select Auto to allow the AMI BIOS to automatically detect the PIO mode. Use this value if the IDE disk drive support cannot be determined.

Select 0 to allow the AMI BIOS to use PIO mode 0. It has a data transfer rate of 3.3 MBs.

Select 1 to allow the AMI BIOS to use PIO mode 1. It has a data transfer rate of 5.2 MBs.

Select 2 to allow the AMI BIOS to use PIO mode 2. It has a data transfer rate of 8.3 MBs.

Select 3 to allow the AMI BIOS to use PIO mode 3. It has a data transfer rate of 11.1 MBs.

Select 4 to allow the AMI BIOS to use PIO mode 4. It has a data transfer bandwidth of 32-Bits. Select Enabled to enable 32-Bit data transfer.



RMC 7132

1U Rackmount System

DMA Mode

Select Auto to allow the BIOS to automatically detect IDE DMA mode when the IDE disk drive support cannot be determined.

Select SWDMA0 to allow the BIOS to use Single Word DMA mode 0. It has a data transfer rate of 2.1 MBs.

Select SWDMA1 to allow the BIOS to use Single Word DMA mode 1. It has a data transfer rate of 4.2 MBs.

Select SWDMA2 to allow the BIOS to use Single Word DMA mode 2. It has a data transfer rate of 8.3 MBs.

Select MWDMA0 to allow the BIOS to use Multi Word DMA mode 0. It has a data transfer rate of 4.2 MBs.

Select MWDMA1 to allow the BIOS to use Multi Word DMA mode 1. It has a data transfer rate of 13.3 MBs.

Select MWDMA2 to allow the BIOS to use Multi-Word DMA mode 2. It has a data transfer rate of 16.6 MBs.

Select UDMA0 to allow the BIOS to use Ultra DMA mode 0. It has a data transfer rate of 16.6 MBs. It has the same transfer rate as PIO mode 4 and Multi Word DMA mode 2.

Select UDMA1 to allow the BIOS to use Ultra DMA mode 1. It has a data transfer rate of 25 MBs.

Select UDMA2 to allow the BIOS to use Ultra DMA mode 2. It has a data transfer rate of 33.3 MBs.

Select UDMA3 to allow the BIOS to use Ultra DMA mode 3. It has a data transfer rate of 66.6 MBs.

Select UDMA4 to allow the BIOS to use Ultra DMA mode 4. It has a data transfer rate of 100 MBs.

The options are Auto, SWDMA_n, MWDMA_n, and UDMA_n.

S.M.A.R.T. For Hard disk drives

Self-Monitoring Analysis and Reporting Technology (SMART) can help predict impending drive failures. Select Auto to allow the AMI BIOS to automatically detect hard disk drive support. Select Disabled to prevent the AMI BIOS from using the S.M.A.R.T. Select Enabled to allow the AMI BIOS to use the S.M.A.R.T. to support hard drive disk. The options are Disabled, Enabled, and Auto.

32Bit Data Transfer

Select Enable to enable the function of 32-bit IDE data transfer. The options are Enabled and Disabled.



RMC 7132

1U Rackmount System

XPCI/PnP Configuration

This feature allows the user to set the PCI/PnP configurations for the following items:

Clear NVRAM

This feature clears the NVRAM during system boot. The options are No and Yes.

Plug & Play OS

Selecting Yes allows the OS to configure Plug & Play devices. (This is not required for system boot if your system has an OS that supports Plug & Play.) Select No to allow the AMI BIOS to configure all devices in the system.

PCI Latency Timer

This feature sets the latency Timer of each PCI device installed on a PCI bus. Select 64 to set the PCI latency to 64 PCI clock cycles. The options are 32, 64, 96, 128, 160, 192, 224 and 248.

PCI IDE Bus Master

When enabled, the BIOS uses PCI bus mastering for reading/writing to IDE drives. The options are Disabled and Enabled.

PCIE Width

This feature selects the bus width of the motherboard's PCIE slots. The options are X8X8X8X8 and X16X8X8.

PCI Slot 1 ~ PCI Slot 4

Use this feature to enable or disable a PCI slot. The options are Disabled and Enabled.

Load Onboard LAN1 Option ROM, Load Onboard LAN2 Option ROM

This feature is to enable LAN OPROM for PXE. This is to boot computers using a network interface. The options are Disabled and Enabled.

Load SAS Option ROM

This feature is to load the Serial Attached SCSI (SAS) option ROM, if available. The options are Disabled and Enabled.



RMC 7132

1U Rackmount System

XSuper IO Device Configuration

Serial Port1 Address/ Serial Port2 Address

This option specifies the base I/O port address and the Interrupt Request address of Serial Port 1 and Serial Port 2. Select Disabled to prevent the serial port from accessing any system resources. When this option is set to Disabled, the serial port physically becomes unavailable. Select 3F8/IRQ4 to allow the serial port to use 3F8 as its I/O port address and IRQ 4 for the interrupt address. The options for Serial Port1 are Disabled, 3F8/IRQ4, 2E8/IRQ3. The options for Serial Port2 are Disabled, 2F8/IRQ3, and 2E8/IRQ3.

Serial Port 2 Mode

Use this feature to configure Serial Port 2 mode. The options are Normal, IrDA and ASK IR. IrDA (Infra-Red Data) is an industry standard for remote control devices. ASK IR (Amplitude Shifted Keying Infra-Red) is a protocol compatible with Sharp® branded PDAs and other infra-red devices.

Floppy Controller

Select Enabled to enable the onboard Floppy Controller. The options are Enabled and Disabled.

XRemote Access Configuration

Remote Access

This allows the user to enable the Remote Access feature. The options are Disabled and Enabled. If Remote Access is set to Enabled, the following items will display:

Serial Port Number

This feature allows the user decide which serial port to be used for Console Redirection. The options are COM 1 and COM 2. An additional option, Onboard IPMI is featured on the X8STi-F/X8STi-3F motherboard only and becomes the default.

Serial Port Mode

This feature allows the user to set the serial port mode for Console Redirection. The options are 115200 8, n 1; 57600 8, n, 1; 38400 8, n, 1; 19200 8, n, 1; and 9600 8, n, 1.

Flow Control

This feature allows the user to set the flow control for Console Redirection. The options are None, Hardware, and Software.





RMC 7132

1U Rackmount System

Redirection After BIOS POST

Select Disabled to turn off Console Redirection after Power-On Self-Test (POST). Select Always to keep Console Redirection active all the time after POST. (Note: This setting may not be supported by some operating systems.) Select Boot Loader to keep Console Redirection active during POST and Boot Loader. The options are Disabled, Boot Loader, and Always.

Terminal Type

This feature allows the user to select the target terminal type for Console Redirection. The options are ANSI, VT100, and VT-UTF8.

VT-UTF8 Combo Key Support

A terminal keyboard definition that provides a way to send commands from a remote console. Available options are Enabled and Disabled.

Sredir Memory Display Delay

This feature defines the length of time in seconds to display memory information. The options are No Delay, Delay 1 Sec, Delay 2 Sec, and Delay 4 Sec.

XHardware Health Configuration

This feature allows the user to monitor Hardware Health of the system and review the status of each item when displayed.

CPU Overheat Alarm

This option allows the user to select the CPU Overheat Alarm setting which determines when the CPU OH alarm will be activated to provide warning of possible CPU overheat.

The options are:

Warning: Any temperature that exceeds the CPU threshold temperature predefined by the CPU manufacturer may result in CPU overheat or system instability. When the CPU temperature reaches this predefined threshold, the CPU and system cooling fans will run at full speed.

o The Early Alarm: Select this setting if you want the CPU overheat alarm (including the LED and the buzzer) to be triggered as soon as the CPU temperature reaches the CPU overheat threshold as predefined by the CPU manufacturer.

o The Default Alarm: Select this setting if you want the CPU overheat alarm (including the LED and the buzzer) to be triggered when the CPU temperature reaches about 5oC above the threshold temperature as predefined by the CPU manufacturer to give the CPU and system fans additional time needed for CPU and system cooling. In both the alarms above, please take immediate action as shown below.



RMC 7132

1U Rackmount System

CPU Temperature

The CPU Temperature feature will display the CPU temperature status as detected by the BIOS.

System Temperature

The item displays the absolute temperature as detected by the BIOS.

CPU Temperature

The item displays the level of CPU temperature (High, Medium, Low) as detected by the BIOS. The information shown in the screen is for your reference only. (See the notes below for more information on PECEI and TControl.)

- o CPU Temperature Setting - Low:

When CPU PECEI (Platform Environment Control Interface) count is below or equal to TControl-100 C. (PECEI Count<=TControl-100 C.)

- o CPU Temperature Setting - Medium: When CPU PECEI count is greater than TControl - 100 C but below TControl. (TControl-100C<PECEI Count<=TControl)

- o CPU Temperature Setting - High: When CPU PECEI count is greater than TControl (TControl<PECEI Count).

Notes:

1. According to Intel's specifications, PECEI and TControl are defined as follows:

- o PECEI (Platform Environmental Control Interface): PECEI is a bus interface that provides a communication channel between Intel processor/chipset components to external thermal monitoring devices. It sends readings from the Digital Thermal Sensor (DTS) located in the processor to an external device for fan control purposes. PECEI replaces the thermal diode available in the older versions of processors.

- o TControl: TControl is a temperature reading from the Digital Thermal Sensor (DTS) in the CPU used for fan speed control mechanisms. It can be referred to as a trigger point to trigger a CPU Overheat/Fan Control alarm.

2. The information provided above is for your reference only. For more information on thermal management, please refer to Intel's Web site at www.Intel.com.



RMC 7132

1U Rackmount System

Fan Speed Control Modes

This feature allows the user to decide how the system controls the speeds of the onboard fans. The CPU temperature and the fan speed are correlative. When the CPU on-die temperature increases, the fan speed will also increase, and vice versa. Select Workstation if your system is used as a Workstation. Select Server if your system is used as a Server. Select "Disabled, (Full Speed @12V)" to disable the fan speed control function and allow the onboard fans to constantly run at the full speed (12V). The Options are: Disabled, 4-pin (Server), 4-pin (Super Quiet) and 4-pin (Workstation).

Fan1 ~ Fan 5 Reading

This feature displays the fan speed readings from fan interfaces Fan1 through Fan5.

Vcore, 3.3Vcc, 12V, V_DIMM, 5V, -12V, 3.3VSB, and VBAT

XACPI Configuration

Use this feature to configure Advanced Configuration and Power Interface (ACPI) power management settings for your system.

USB Device WakeUp

This feature is used to awaken from Standby mode by a Universal Serial Bus (USB) device (such as, a USB mouse or USB keyboard). The options are Enabled and Disabled.

PS/2 KB/MS WakeUp

This feature is used to awaken from Standby mode by a PS/2 mouse or PS/2 keyboard. The options are Enabled and Disabled.

ACPI Aware O/S

Enable ACPI support if it is supported by the OS to control ACPI through the Operating System. Otherwise, disable this feature. The options are Yes and No.

Headless Mode

This feature is used to enable system to function without a keyboard, monitor or mouse attached. The options are Enabled and Disabled.

ACPI Version Features

The options are ACPI v1.0, ACPI v2.0 and ACPI v3.0. Please refer to ACPI's website for further explanation: <http://www.acpi.info/>



RMC 7132

1U Rackmount System

XTrusted Computing

TCG/TPM Support

Select Yes on this item and enable the TPM jumper on the motherboard to enable TCG (TPM 1.1/1.2)/TPM support in order to improve data integrity and network security. The options are No and Yes.

If this feature is set to Yes, the following items will display:

Execute TPM Command

Select Enabled to allow the user to change executable TPM commands and TPM settings. Select Don't Change to keep the current TPM settings. The options are Don't Change, Enabled, and Disabled.

TPM Enable/Disable Status

This item displays the status of TPM Enabled/Disabled state.

TPM Owner Status

This item displays the status of TPM Ownership.

XIPMI Configuration

Intelligent Platform Management Interface (IPMI) is a set of common interfaces that IT administrators can use to monitor system health and to manage the system as a whole. For more information on the IPMI specifications, please visit Intel's website at www.intel.com.

Status of BMC

Baseboard Management Controller (BMC) manages the interface between system management software and platform hardware. This is an informational feature which returns the status code of the BMC micro controller.

IPMI Function

Select Enabled to turn on this motherboard's IPMI capability. The options are Disabled and Enabled.

View BMC System Event Log

This feature is used to view any BMC events. It shows the total number of entries and will allow the viewing of each event by scrolling down on an Entry Number and pressing Enter.



RMC 7132

1U Rackmount System

Clear BMC System Event Log

This feature is used to clear the System Event Log. Caution: Any cleared information is unrecoverable. Make absolutely sure you no longer need any data stored in the log before clearing the BMC Event Log.

Set LAN Configuration

Set this feature to configure the IPMI LAN adapter with a network address.

Channel Number - Enter the channel number for the SET LAN Config command. This is initially set to [1]. Press "+" or "-" on your keyboard to change the Channel Number.

Channel Number Status - This feature returns the channel status for the Channel Number selected above: "Channel Number is OK" or "Wrong Channel Number".

IP Address - Enter the IP address for this machine. This should be in decimal and in dotted quad form (i.e., 192.168.10.253). The value of each three-digit number separated by dots should not exceed 255.

MAC Address - The BIOS will automatically enter the MAC address of this machine, however it may be over-riden. MAC addresses are 6 two-digit hexadecimal numbers (Base 16, 0 ~ 9, A, B, C, D, E, F) separated by dots. (i.e.,

00.30.48.D0.D4.60)

Subnet Mask - Subnet masks tell the network which subnet this machine belongs to. The value of each three-digit number separated by dots should not exceed 255.

Set PEF Configuration

Set this feature to configure the Platform Event Filter (PEF). PEF interprets BMC events and performs actions based on pre-determined settings or 'traps' under IPMI 1.5 specifications. For example, powering the system down or sending an alert when a triggering event is detected.

The following will appear if PEF Support is set to Enabled. The default is Disabled.

PEF Action Global Control - These are the different actions based on BMC events. The options are Alert, Power Down, Reset System, Power Cycle, OEM Action, Diagnostic Interface.

Alert Startup Delay - This feature inserts a delay during startup for PEF alerts. The options are Enabled and Disabled.

PEF Alert Startup Delay - This sets the pre-determined time to delay PEF alerts after system power-ups and resets. Refer to Table 24.6 of the IPMI 1.5 Specification for more information at www.intel.com. The options are No Delay, 30 sec, 60 sec, 1.5 min, 2.0 min.



RMC 7132

1U Rackmount System

Startup Delay - This feature enables or disables startup delay. The options are Enabled and Disabled.

PEF Startup Delay - This sets the pre-determined time to delay PEF after system power-ups and resets. Refer to Table 24.6 of the IPMI 1.5 Specification for more information at www.intel.com. The options are No Delay, 30 sec, 60 sec, 1.5 min, 2.0 min.

Event Message for PEF Action - This enables or disables Event Messages for PEF action. Refer to Table 24.6 of the IPMI 1.5 Specification for more information at www.intel.com. The options are Disabled and Enabled.

BMC Watch Dog Timer Action

Allows the BMC to reset or power down the system if the operating system hangs or crashes. The options are Disabled, Reset System, Power Down, Power Cycle.

BMC WatchDog TimeOut [Min:Sec]

This option appears if BMC Watch Dog Timer Action (above) is enabled. This is a timed delay in minutes or seconds, before a system power down or reset after an operating system failure is detected. The options are [5 Min], [1 Min], [30 Sec], and [10 Sec].

XEvent Log Configuration

View Event Log

Use this option to view the System Event Log.

Mark all events as read

This option marks all events as read. The options are OK and Cancel.

Clear event log

This option clears the Event Log memory of all messages. The options are OK and Cancel.

RMC 7132

1U Rackmount System

7-4 Security Settings

The AMI BIOS provides a Supervisor and a User password. If you use both passwords, the Supervisor password must be set first.



Supervisor Password

This item indicates if a supervisor password has been entered for the system. Clear means such a password has not been used and Set means a supervisor password has been entered for the system.

User Password:

This item indicates if a user password has been entered for the system. Clear means such a password has not been used and Set means a user password has been entered for the system.

Change Supervisor Password

Select this feature and press <Enter> to access the submenu, and then type in a new Supervisor Password.

User Access Level (Available when Supervisor Password is set as above)

Available options are Full Access: grants full User read and write access to the Setup Utility, View Only: allows access to the Setup Utility but the fields cannot be changed, Limited: allows only limited fields to be changed such as Date and Time, No Access: prevents User access to the Setup Utility.



RMC 7132

1U Rackmount System

Change User Password

Select this feature and press <Enter> to access the submenu , and then type in a new User Password.

Clear User Password (Available only if User Password has been set) Password Check

Available options are Setup and Always.

Boot Sector Virus Protection

When Enabled, the AMI BOIS displays a warning when any program (or virus) issues a Disk Format command or attempts to write to the boot sector of the hard disk drive. The options are Enabled and Disabled.

RMC 7132

1U Rackmount System

7-5 Boot Settings

Use this feature to configure Boot Settings:



XBoot Device Priority

This feature allows the user to specify the sequence of priority for the Boot Device. The settings are 1st boot device, 2nd boot device, 3rd boot device, 4th boot device, 5th boot device and Disabled.

- o 1st Boot Device - 1st Floppy Drive
- o 2nd Boot Device - [USB: XXXXXXXXXXX]
- o 3rd Boot Device - [SATA: XXXXXXXXXXX]
- o 4th Boot Device - [Network: XXXXXXXXXXX]

XHard Disk Drives

This feature allows the user to specify the sequence of priority from the available Hard Drives.

- o 1st Drive [SATA: XXXXXXXXXXX]
- o 2nd Drive [SATA: XXXXXXXXXXX]

RMC 7132

1U Rackmount System

XRemovable Drives

This feature allows the user to specify the boot sequence from available Removable Drives. The settings are 1st boot device, 2nd boot device, and Disabled.

- o 1st Drive
- o 2nd Drive - [USB: XXXXXXXXXX]\

XCD/DVD Drives

This feature allows the user to specify the boot sequence from available CD/DVD Drives (i.e., 1st Drive, 2nd Drive, etc).

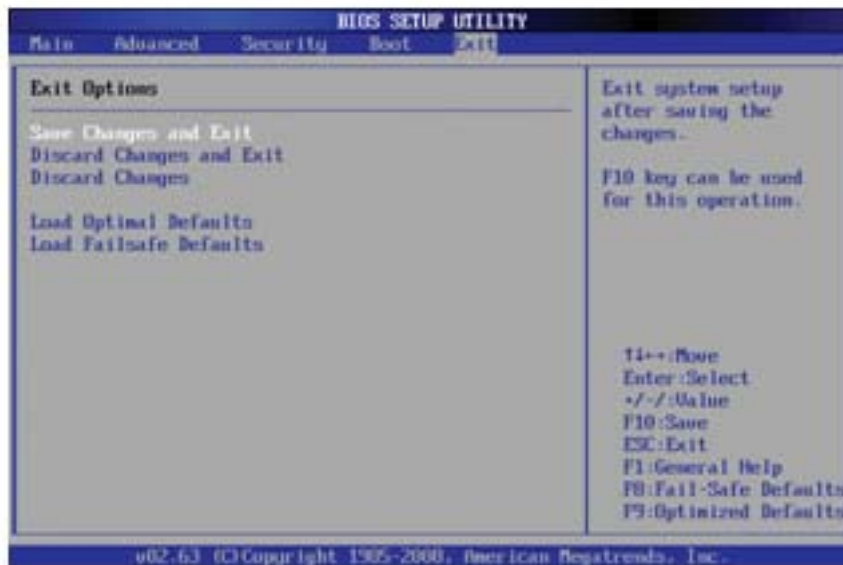

7-6 Exit Options

Select the Exit tab from the AMI BIOS Setup Utility screen to enter the Exit BIOS Setup screen.

Save Changes and Exit

When you have completed the system configuration changes, select this option to leave the BIOS Setup Utility and reboot the computer, so the new system configuration parameters can take effect. Select Save Changes and Exit from the Exit menu and press <Enter>.



RMC 7132

1U Rackmount System

Discard Changes and Exit

Select this option to quit the BIOS Setup without making any permanent changes to the system configuration, and reboot the computer. Select Discard Changes and Exit from the Exit menu and press <Enter>.

Discard Changes

Select this option and press <Enter> to discard all the changes and return to the AMI BIOS Utility Program.

Load Optimal Defaults

To set this feature, select Load Optimal Defaults from the Exit menu and press <Enter>. Then, select OK to allow the AMI BIOS to automatically load Optimal Defaults to the BIOS Settings. The Optimal settings are designed for maximum system performance, but may not work best for all computer applications.

Load Fail-Safe Defaults

To set this feature, select Load Fail-Safe Defaults from the Exit menu and press <Enter>. The Fail-Safe settings are designed for maximum system stability, but not for maximum performance.

Appendix A POST Error Beep Codes

This section lists POST (Power On Self Test) error beep codes for the AMI BIOS. POST error beep codes are divided into two categories: recoverable and terminal. This section lists Beep Codes for recoverable POST errors.

Recoverable POST Error Beep Codes

When a recoverable type of error occurs during POST, BIOS will display a POST code that describes the problem. BIOS may also issue one of the following beep codes:

1 long and two short beeps - video configuration error

1 repetitive long beep - no memory detected

1 continuous beep with the front panel Overheat LED on - system overheat

8 short beeps - display memory read/write error

Appendix B Installing the Windows OS

After all hardware components have been installed, you must first configure Intel South Bridge RAID Settings before you install the Windows OS and other software drivers. To configure RAID settings, please refer to RAID Configuration User Guides posted on our website at www.supermicro.com/support/manuals.

Please note that the Intel ICH10R South Bridge used on this motherboard does not support HostRAID settings.

B-1 Installing Windows on RAID Systems

1. Insert Microsoft's Windows XP/2003 Setup CD in the CD drive and the system will start booting up from CD.
2. Press the <F6> key when the message "Press F6 if you need to install a third party SCSI or RAID driver" displays.
3. When the Windows XP/2003 Setup screen appears, press "S" to specify additional device(s).
4. Insert the driver diskette "Intel AA RAID XP/2003 Driver for ICH10R" into Drive A: and press the <Enter> key.
5. Choose the Intel(R) ICH10R SATA RAID Controller from the list indicated in the XP/2003 Setup Screen and press the <Enter> key.
6. Press the <Enter> key to continue the installation process. (If you need to specify any additional devices to be installed, do it at this time.) Once all devices are specified, press the <Enter> key to continue with the installation.
7. From the Windows XP/2003 Setup screen, press the <Enter> key. The XP/2003 Setup will automatically load all device files and then continue installing Windows.
8. After the Windows XP/2003 OS installation is complete, the system will automatically reboot.



RMC 7132

1U Rackmount System

B-2 Installing Windows on Non-RAID Systems

1. Insert Microsoft's Windows XP/2003 Setup CD in the CD drive and the system will start booting up from the CD.
2. Press the <F6> key when the message "Press F6 if you need to install a third party SCSI or RAID driver" displays.
3. When the Windows XP/2003 Setup screen appears, press "S" to specify additional device(s).
4. Insert the driver diskette you want to install into Drive A: and press the <Enter> key.
5. Press the <Enter> key to proceed with the installation process. (If you need to specify any additional devices to be installed, do it at this time.) Once all devices are specified, press the <Enter> key to continue with the installation.
6. From the Windows XP/2003 Setup screen, press the <Enter> key. The XP/2003 Setup will automatically load all device files and then continue with the Windows XP/2003 installation.
7. After the Windows XP/2003 OS installation is complete, the system will automatically reboot.
8. Insert the Supermicro Setup CD that came with your system into the CD drive during system boot, and the main screen shown on page 5-26 will display. Follow the instructions given to complete the installation.



RMC 7132

1U Rackmount System

Appendix C Specifications

Processors

Single Intel® Core™ i7, Core™ i7 Extreme processors and future Intel Nehalem processor families (next generation Intel Xeon® processor)

Note: Please refer to the motherboard specifications pages on our web site for updates on supported processors.

Chipset

Intel X58/ICH10R chipset

BIOS

4 Mb AMI SPI Flash ROM

Memory Capacity

Six 240-pin DIMM slots that can support up to 24 GB of unbuffered ECC/non- ECC DDR2-1333/1066/800 SDRAM

Note: See the memory section in Chapter 5 for details.

SATA Controller

On-chip (ICH10R) 3 Gb/s Intel SATA controller

Drive Bays

One internal fixed drive bay for one (1) 3.5" hard drive

PCI Expansion Slots

One PCI-E 2.0 x16 slot

Motherboard

Model: X7STi /X7STi-LN4

Form Factor: ATX

Dimensions: 12 x 9.6 in (305 x 244 mm)

Chassis

Model: SC811TS-280 (1U Rackmount)

Dimensions (both): (WxHxD) 17.2 x 1.7 x 22.6 in. (437 x 43 x 574 mm)

ACNODES

661 Brea Canyon Rd., Suite 3
Walnut, CA 91789
tel: 909.598.7388, fax: 909.598.0218

© Copyright 2009 Acnodes, Inc.
All rights reserved. Product description and product specifications
are subject to change without notice. For latest product information,
please visit Acnodes' web site at www.acnodes.com.



RMC 7132

1U Rackmount System

Weight

Gross Weight: 30 lbs. (13.6 kg.)

System Input Requirements

AC Input Voltage: 100-240 VAC (auto-range)

Rated Input Current: 5A max (100-240V)

Rated Input Frequency: 50 to 60 Hz

Power Supply

Rated Output Power: 280W

Rated Output Voltages: +3.3V (16A), +5V (20A), +12V (16A), -12V (0.5A), +5Vsb (2A)

Operating Environment

Operating Temperature: 10° to 35° C (50° to 95° F)

Non-operating Temperature: -40° to 70° C (-40° to 158° F)

Operating Relative Humidity: 8% to 90% (non-condensing)

Non-operating Relative Humidity: 5 to 95% (non-condensing)

Regulatory Compliance

Electromagnetic Emissions: FCC Class A, EN 55022 Class A, EN 61000-3-2/-3-3, CISPR 22 Class A

Electromagnetic Immunity: EN 55024/CISPR 24, (EN 61000-4-2, EN 61000-4-3, EN 61000-4-4, EN 61000-4-5, EN 61000-4-6, EN 61000-4-8, EN 61000-4-11)

Safety: CSA/EN/IEC/UL 60950-1 Compliant, UL or CSA Listed (USA and Canada), CE Marking (Europe)

California Best Management Practices Regulations for Perchlorate Materials: This Perchlorate warning applies only to products containing CR (Manganese Dioxide) Lithium coin cells. "Perchlorate Material-special handling may apply. See www.dtsc.ca.gov/hazardouswaste/perchlorate"



661 Brea Canyon Rd., Suite 3
Walnut, CA 91789
tel: 909.598.7388, fax: 909.598.0218

© Copyright 2005 Acnodes, Inc.
All rights reserved. Product description and product specifications are subject to change without notice. For latest product information, please visit Acnodes' web site at www.acnodes.com.

Free Manuals Download Website

<http://myh66.com>

<http://usermanuals.us>

<http://www.somanuals.com>

<http://www.4manuals.cc>

<http://www.manual-lib.com>

<http://www.404manual.com>

<http://www.luxmanual.com>

<http://aubethermostatmanual.com>

Golf course search by state

<http://golfingnear.com>

Email search by domain

<http://emailbydomain.com>

Auto manuals search

<http://auto.somanuals.com>

TV manuals search

<http://tv.somanuals.com>