

FIELD-READY



ZX STATION

USER MANUAL



ZMicrosystems

Regulatory

FCC INFORMATION



WARNING



TO PREVENT FIRE OR SHOCK HAZARDS, DO NOT EXPOSE THIS UNIT TO RAIN OR MOISTURE. ALSO, DO NOT USE THIS UNIT'S POLARIZED AC PLUG WITH AN EXTENSION CORD RECEPTACLE OR OTHER OUTLETS UNLESS ALL THREE PRONGS CAN BE FULLY INSERTED.

1. Use the power and video cables supplied with this equipment to help prevent interference with radio and television reception. The use of cables and adapters may cause interference with electronic equipment in the vicinity of this unit.



2. This equipment has been tested and found to comply with the limits for Class "A" digital devices, pursuant to certain limits imposed

could void user's authority to operate the equipment

by Part 15 of the FCC rules. These limits are designed to provide reasonable protection against harmful interference when equipment is operated in commercial environments. This equipment generates, uses and can radiate radio frequency energy, and, if not installed and used in accordance with the instruction manual, may cause harmful interference to radio communications.

3. Operation of this equipment in a residential area is likely to cause interference in which case the user will be required to correct the interference at his own expense. Changes or modifications not expressly approved by Z Microsystems



CAUTION



RISK OF ELECTRIC SHOCK - DO NOT OPEN

CAUTION: TO REDUCE THE RISK OF ELECTRIC SHOCK, DO NOT REMOVE COVER (OR BACK OF UNIT). NO USER SERVICEABLE PARTS INSIDE. REFER SERVICING TO QUALIFIED PERSONNEL.



This symbol warns the user that insulated voltage within the unit may have sufficient magnitude to cause electric shock. Therefore, it is dangerous to make any kind of contact with any part inside this unit.



This symbol alerts the user that important literature concerning the operation and maintenance of this unit has been included. Therefore it should be read carefully in order to avoid any problems.

Contents

STARTING POINT	4	INTERNAL ACCESS	24
Shipment Contents	4	Opening The ZX Station	24
User Manual	4	Closing The ZX Station	24
Product Description	5	MAINTENANCE	25
Drawing of Slide Installation	6	Clean Front Panel	25
Tools Required	7	TROUBLESHOOTING	26
Precautions	7	Front Panel	26
INSTALL SLIDES	8	ZX Station Configuration	26
Slide Removal	8	SPECIFICATIONS	27
Install The Slides In Rack Frame	9	APPENDIX	28
INSTALL ZX STATION	10	Warranty	28
Install The ZX Station In Rack		Y2K Compliance	31
Frame	10	SUPPORT	32
Installation Test	10	Further Help	32
Final Adjustments	11	Replacing Parts	33
Securing ZX Station In Rack Frame	11	Providing Feedback	33
Installing Cables	12		
OPERATION	13		
Powering Up	13		
Controls And Displays	13		
TranzPak 6	14		
TranzPak 6 Front Panel	15		
Function Switch	16		
Disk Module Handle	16		
Front Panel Functioning	17		
Installing Disk Module	18		
Powering Up The Hard Disk	19		
Setting The SCSI ID	19		
Function Switch Electrical			
Description	20		
Function Switch Versions	20		
Locking The Disk Module And			
Hard Disk	20		
Operating The Disk Module	22		
Powering Down The Hard Disk	22		
Removing The Disk Module	22		
Carrying The Disk Module	23		
Installing YourOwn Hard Disk			
Drive	23		

Starting Point

Congratulations on selecting a rugged field-ready ZX Station -- the ultimate processing powerhouse available.

SHIPMENT CONTENTS USER MANUAL

The ZX Station shipping box contains the following:

- The ZX Station
- AC Power Cable
- User Manual

Remember to save your original shipping container and packing material to transport or ship the ZX Station.

The User Manual comes in two formats: printed hardcopy or CD-ROM. This Manual is also available on the Z Microsystems website (www.zmicro.com).

We recommend you read this manual as follows:

Carefully follow the instructions in the Installation chapter for hookup and initial control settings. Refer to the Operation chapter for a complete description of all the user controls, and the Maintenance and Troubleshooting chapters for care and correcting any unforeseen problems with the system. The Appendix chapters are provided for quickly finding technical information about the ZX Station.

Starting Point

PRODUCT DESCRIPTION



The ZX Station, with its rugged removable hard drive, is the ultimate processing system powerhouse available. This rugged workstation and server is designed to be rack mounted in a 19" RETMA rack enclosure.



At only 7" high (4U), the ZX Station is as rugged as it looks sharp. The ZX Station is built with the powerful Intel or Sun processor.



The ZX Station is built of light-weight aluminum construction with trouble-free dust filtration for easy maintenance in racks or fielded transit cases.

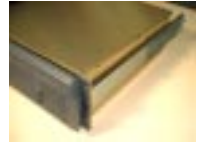

Expansion room is available inside the ZX Station to add other computer components. The fold-down front allows easy access to panel-mounted components.

Designed to be deployed in transit cases, shelters, vehicles, airplanes, ships and military command centers, the ZX Station offers the latest in processor and components.

The ZX Station

offers fixed and removable SCSI peripherals in an environmentally protected enclosure for easy maintenance.

The ZX Station is designed to work with a large selection of other Z Microsystems

FIELD-READY equipment ---flat panel displays, storage devices and accessories.

The ZX Station brings unmatched reliability, manageability and expandability to tactical environments.

Starting Point

1. 4 Screws #10-32 x .75 Oval Hd Phil
2. 4 Washer, Finishing, #10 SS
3. 4 Washer # 10, Nylon, 82 Deg
4. 8 Screws #10-32 x .375 Low Hd
5. 8 Screws #10-32 x .75 Pan Hd SEM

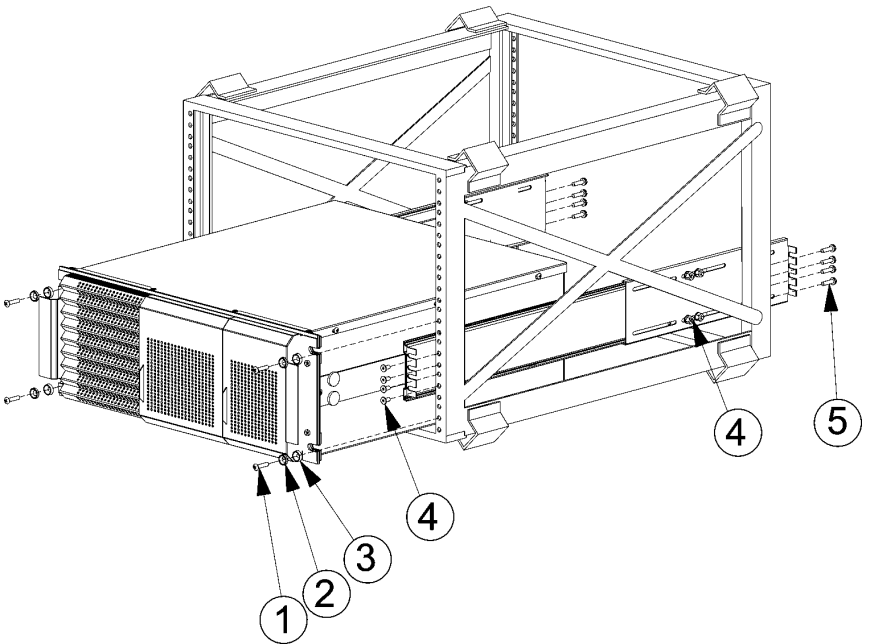

Starting Point

TOOLS REQUIRED



DANGER: To avoid shock hazard:

- *Do not connect or disconnect the ZX Station during an electrical storm.*
- *The power cord plug must be connected to a properly wired and grounded power outlet.*
- *Any equipment to which the ZX Station will be attached must also be connected to properly wired and grounded power outlets.*

Required Tools and Equipment

- Phillips screwdriver with about 10" shaft.
- Adjustable wrench or box wrenches

PRECAUTIONS



NOTE: For the fastest and easiest installation of the ZX Station, follow these steps in the sequence they are presented.

In preparation to install the ZX Station, take the following precautionary steps:

Verify the ZX Station power switch is off. If the power is off, the light on the front panel will not be illuminated.

Install Slides

SLIDE REMOVAL



Lay the ZX Station on a workbench.



The slide rail will reach a stop about half way out.

This is a safety stop to prevent the ZX Station from sliding out too far while mounted to the rack.

Simultaneously press in the safety catches on each slide rail and remove the slide rails all the way off the back of the ZX Station.



The slides should now be separated from the ZX Station.

Install Slides

INSTALL THE SLIDES IN CABINET FRAME



Use the proper screws (from left to right).

Pancakehead Phillips screw to install the front of the slider rail and top of lid.

Panhead Phillips screw and washer to install the back of the slider rail.

Ovalhead Phillips screw, stainless steel and nylon receptacle washers to install the front panel.



On the front of the RETMA Rail, use three pancakehead Phillips screws per side to secure the right and left slider rails.

DO NOT tighten these screws to allow for adjustment of the ZX Station within the cabinet frame.



On the rear of the RETMA Rail, use three panhead Phillips screws with washers per side to loosely secure the right and left rear slider mount to the RETMA Rail.

DO NOT tighten these screws fully at this time.



On the slide rails, using a Phillips screwdriver, loosen the screws on each side.

An adjustable wrench or box wrench may be used to hold the nut on the other side of the slide rail.



Tighten the slide mount to the cabinet frame on the back of the cabinet frame.

Make sure to hold the slide mounts hard against the rack rail.

Install ZX Station

INSTALL THE ZX STATION IN CABINET FRAME

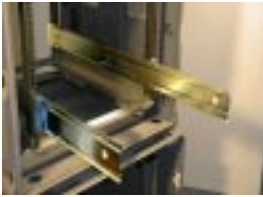

Pull the two ZX Station slides out until they lock.



Hold the ZX Station by each side, with the front towards you.

Guide the ZX Station into the slide rails and slide the ZX Station in until it stops. If the ZX Station binds, the rollers are not properly in the slide rails.



Simultaneously press in the catches on each slide and push the ZX Station all the way into the cabinet frame.

The ZX Station should slide in and out easily.

INSTALLATION TEST



Slide the ZX Station in and out several times. The ZX Station should easily close completely.



To be sure the slide and mount assembly are aligned properly, slide the ZX Station in and out several times.

If the ZX Station binds during sliding, do the following:

Install ZX Station

FINAL ADJUSTMENTS



Slide the ZX Station partially out.

Lift the ZX Station while tightening the pancakehead Phillips screws in the front slider bracket.



Go to the rear of the cabinet to tighten the slider rail screws. If there is not enough room to work at the back of the cabinet, the ZX Station may need to be removed to tighten the rail screws.

The ZX Station should now slide in and out smoothly. If not, repeat these steps.



The ZX Station should slide in and out easily. If not, repeat these adjustment steps.

SECURING ZX STATION IN CABINET FRAME



Use four ovalhead Phillips screws, stainless steel and nylon receptacle washers to secure the front panel of the ZX Station to the front of the cabinet frame.

Install ZX Station

INSTALLING CABLES



WARNING: *Be sure all electrical power to the cabinet is off before connecting any of the cables.*



WARNING: *There is a key guide for alignment on all the cables. Be sure the cable plug and receptacles are aligned properly using the key guide. Misalignment can cause short circuiting.*

Several cables connect the back of the ZX Station to other equipment, depending upon the ZX Station internal configuration.

- Power cable
- Video cable
- Printer cable
- Keyboard cable
- Mouse cable
- and others



The power cable coming out of the back of the ZX Station should be connected to an appropriately grounded 110 VAC supply.

After connecting the power cable, turn the power switch next to the power cable in the back to the on position (circle down) and leave it on until disconnect the power cable.

POWERING UP



Switch the ZX Station on by pushing and releasing the power switch located on the right of the center front panel.

CONTROLS AND DISPLAYS



Peripheral options from left to right, top to bottom:

- Empty slot front cover.
- CD-ROM.
- Power light.
- Power switch. Press down and release for on.



On the right panel of the ZX Station, from left to right, top to bottom:

- 3-1/2 inch floppy drive.
- Handle for TranzPak 6 removable memory drive.
- Power Light.
- Active Light.
- SCSI ID Set Switch
- Read-only light.
- SCSI ID.
- Removable memory drive security lock. Push drive all way in and rotate security lock clockwise to lock drive in place.

Operation

TRANZPAK 6



The rugged TranzPak 6 is a removable mass storage system.

TranzPak 6 provides 4.5GB to 36.4GB of archiving power, a wide range of security logistics and flexibility in media selection.



Ultra rugged TranzPak 6 multipurpose storage modules house any 3.5" or 5.25" peripheral devices.



The high life-cycle connectors are designed to last in excess of 25,000 cycles.



These rugged high-performance modules withstand daily insertion and removal.



Aluminum housing hold drives that float in precision engineered vibration dampening elastomeric gel to withstand punishing MIL-810E 515V vibration test.



TranzPaks can be locked in to or out of the SmartStor system.

TRANZPAK 6

FRONT PANEL

The front panel of the TranzPak 6 contains three LEDs, a SCSI ID indicator, a push-switch to set the SCSI ID and a function switch.

The top LED indicates power to the hard disk drive. The middle LED indicates an active state when the computer is accessing the TranzPak 6. The bottom LED indicates a read only state.

The SCSI ID Indicator shows a number, which is the setting for the disk module.

The SCSI ID Set Switch is a push-to-set switch that advances the SCSI ID Indicator by one number with each push.

The Function Switch has four positions.

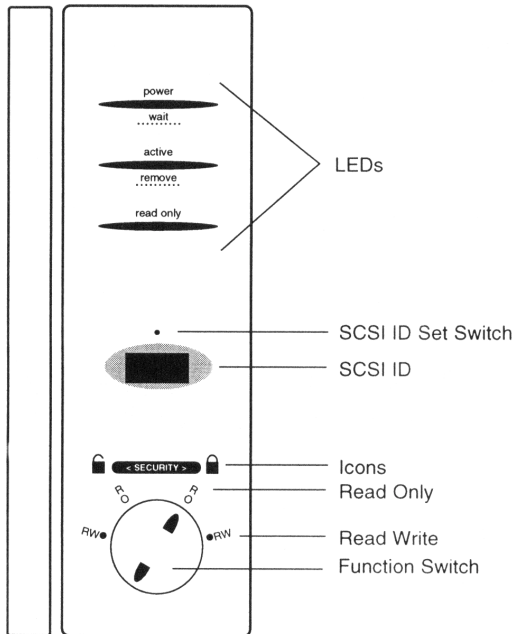





Operation

TRANZPAK 6

FUNCTION SWITCH

The function switch has multiple features and is used for a variety of tasks in operating a disk module and its internal disk drive.

 <p>Switch Position Left RW (read-write)</p> <p>Handle Mode Unlocked</p> <p>Purpose Disk in RW state (unlocked)</p>	 <p>Switch Position Left RO (read only)</p> <p>Handle Mode Unlocked</p> <p>Purpose Disk in RO state (unlocked)</p>	 <p>Switch Position Right RO (read only)</p> <p>Handle Mode Locked</p> <p>Purpose Lock disk in RO state</p>	 <p>Switch Position Right RW (read-write)</p> <p>Handle Mode Locked</p> <p>Purpose Lock disk in RW state</p>
---	--	---	--

DISK MODULE HANDLE

The handle serves several functions: (1) it is an on/off power switch for the internal hard disk drive, (2) it is a mechanical lock, and (3) it disengages the module latch to allow removal of the disk module from the docking

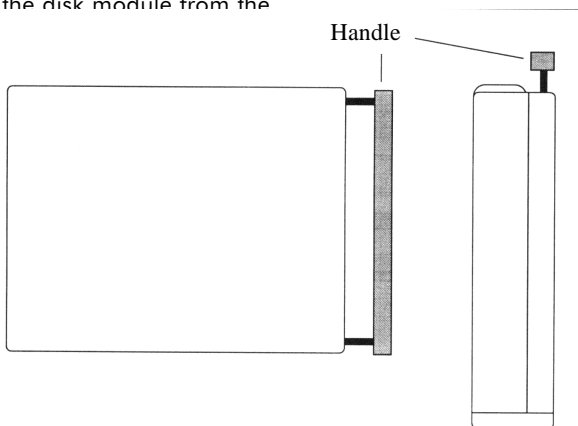

Handle used in disk module insertion.

Handle used to carry disk module.

FRONT PANEL FUNCTIONING

The following Table describes the functioning of the TranzPak 6 disk module's front panel during various functions.

Function	Handle Position	Power LED	Active LED	Read Only	Switch Position
Installing Module	Any	Off	Off	Off	Left RW or RO
Module Installed No Disk Power	2, 3 or 4	Off	Blinking Green	Off	Either RW
				On **	Either RO
Powering Up Disk	1	Steady Green	Steady Green*	Off	Either RW
				On **	Either RO
Disk Unlocked Powered Up	1	Steady Green	Off	Off	Left RW
				On **	Left RO
Disk Locked Powered Up	1	Steady Green	Off	Off	Right RW
				On **	Right RO
Accessing Disk (I/O)	1	Steady Green	Flickers When In/Out*	Off	Either RW
				On **	Either RO
Powering Down Disk	2	Flashing Red Then Off	Off; Then Blinking Green	Off	Left RW
				On **	Left RO
Disk Locked Power Down	3 (Locked)	Off	Blinking Green	Off	Right RW
				On **	Right RO
Module Ready for Removal	4	Off	Blinking Green	Off	Left RW
				On **	Left RO
Removing Module	5	Off	Goes Off	Goes Off	Left RW or RO

Handle Positions

1. **Fully In—Disk Powered** (locked when function switch is on right RW or RO position)
2. **In** (but not against front panel)
3. **Locked—Disk Not Powered** (switch in right RW or RO)
4. **Out** (stopped by spring)
5. **Fully Out** (handle fully extended)

*** Note:** The light sequence of the **active** LED depends on the installed disk and may be different than this table.

**** Note:** The **read only** LED turns on when the switch is in either RO position. Your disk may or may not be Read-Only, depending on whether the disk manufacturer requires a power shut-down to change from Read/Write to Read-Only.

Operation

INSTALLING DISK MODULE



NOTE: The disk module can be installed with the disk module handle in any of its five positions and the function switch in any of its four positions. However, it is recommended that the handle be pulled out and that the function switch be in an unlocked mode. If the disk module is plugged into the docking base with its handle in Position 1, the hard disk will immediately start to spin up.

Although the handle does not have to be used for supporting the module during installation, it is designed as an installation aid by holding the entire weight of a loaded disk module in any position.

It allows the disk module to be held with one hand so that it can be guided into the docking base with the other hand.

With the handle extended from the disk module, grasp the handle and guide it into the docking base.

Push firmly on the disk module front panel until the disk module is fully seated.

You will hear a snap or a click that indicates the module latch locking mechanism is engaged.

The center active light (green LED) on the front panel will blink, indicating that there is power going to the disk module.



NOTE: Refer to the TranzPak 6 User Manual for details about system operations.

POWERING UP THE HARD DISK

The disk module handle is the on/off power switch for the hard disk drive. When the handle is pushed fully in, power is applied to the hard disk drive inside the disk module.

The hard disk will spin and the light green power LED will illuminate, staying illuminated as long as the handle is fully in.

SETTING THE SCSI ID



NOTE: It is important that each disk module be given an ID (from 0 through 6) that is not used by any other Z Microsystems' disk module on the same bus, or any other device, such as a tape drive or CD-ROM that may already be on the bus.



NOTE: Depending on the computer of the host computer, the choice of ID number for the TranzPak 6 disk module may be limited. Some operating systems reserve certain ID numbers for disk drives. Consult the computer's User Guide if the initial ID setting is not recognized by the host operating system.



NOTE: The host computer may or may not recognize the addition of a device on the SCSI bus. The computer may have to be rebooted after adding a new device. Refer to the operating system manual.



NOTE: Refer to the TranzPak 6 User Manual for details about system operations.

When there is power going to the disk module, the SCSI Identification (ID) number appears in a window above the function switch on the disk module front panel.

At the top of that window is a small hole in the panel. To set or change the SCSI ID, use a small blunt-end probe and gently but firmly press the switch that is behind the panel. Each push (click) advances the ID by one number.

Operation

FUNCTION SWITCH ELECTRICAL DESCRIPTION



NOTE: Some disk manufacturers require that the power to the disk be cycled after setting it to a write-protect mode in order to use the write-protect feature. The only way to determine if the disk requires power-down to change to Read-Only is to turn the function switch to a RO position, then try to write to the disk.

The function switch has four positions:

- Two Read/Write (RW). The hard disk can be fully accessed by the host computer. There is no front panel LED to indicate this position.
- Two Read-Only (RO). The orange Read-Only LED will be lit.

FUNCTION SWITCH VERSIONS

The function switch has two modes:

- Handle locked
- Handle unlocked

The function switch also has two versions:

- Knob
- Key lock

The switch functions identically in both versions. The only difference is that with the key lock version, a key is required to be inserted into a lock in order to change the position of the switch.

LOCKING THE DISK MODULE AND HARD DISK

On the disk module front panel on each side of the word SECURITY there are small padlock icons.

The left icon indicates an unlocked-handle mode when the function switch is in one of its two left positions (either RW or RO). The right icon indicates a locked-handle mode when the function switch is in one of its two right positions (either RW or RO).



NOTE: Refer to the TranzPak 6 User Manual for details about system operations.

Operation

LOCKING THE DISK MODULE AND HARD DISK

When the function switch knob is in either the left two disk accessing positions, the disk module handle can be moved freely from being Fully In to power the hard disk, to being Fully Out to remove power from the hard disk drive and to remove the module from the docking base.

When the function switch knob is in either of the right two positions, the disk module handle is locked and cannot be moved. The disk module is locked in the docking base, and the hard disk is locked in either a powered or unpowered state (depending on the position of the module handle).

In either a Read/Write or Read-Only disk accessing state (depending on the position of the function switch).

The main reasons for using a locked position are to prevent unauthorized reading and/or writing to the hard disk, and unauthorized removal of the disk module.

Depending on the module handle position, the hard disk drive can be locked with or without power.

Both the knob and key lock version of the function switch operate in the same way. The only difference is that with the key lock version, a key is needed to change all positions of the function switch. When the key is removed, the function switch position cannot be changed.



WARNING: Be sure to return the function switch to the unlocked mode before attempting to remove the disk module.



NOTE: Refer to the TranzPak 6 User Manual for details about system operations.

Operation

OPERATING THE DISK MODULE



NOTE: Refer to the operating system User Manual for the operation of the specific hard disk drive.



NOTE: Depending on the host operating system, the computer may or may not have to be rebooted after adding a new device. Refer to the operating system User Manual.

Once the hard disk is operational and set to the desired mode, it is ready to be used on the SCSI bus.

POWERING DOWN THE HARD DISK



WARNING: Do not attempt to pull the handle further out while the red wait LED flashes. Movement of the disk module could cause physical damage to the hard disk.

Before the disk can be powered down, the disk module handle must be moved from the Fully In position to the In position.

The Power/Wait LED changes color from green to red and begins to flash indicating wait. There is also a single short tone, which is an audible acknowledgment that power was removed from the hard disk drive.

The flashing red light will remain for about 15 seconds, which is the time-down or spin-down period. The light then will go out

REMOVING THE DISK MODULE



NOTE: Refer to the TranzPak 6 User Manual for details about system operations.

When the red Power/Wait LED extinguishes, the green center Active/Remove LED will start to blink, indicating that the disk module can be safely removed from the docking base. Pull the handle Fully Out.

The handle is designed to require a firm pull in order to prevent accidental removal of the disk module. The module will disengage from the docking base and can now be removed.

CARRYING THE DISK MODULE

The handle can be used to carry the disk module. No special precautions are needed.

INSTALLING YOUR OWN HARD DISK DRIVE

Refer to the TranzPak 6 User Manual for detailed instructions on installing your own hard disk drive into the ZX Station.

Subjects covered include:

- Open the Module
- Remove the Shock Mounts
- Install the Shock Mounts Onto Disk Drive
- Install the SCSI ID Harness Onto Disk Drive
- Install the DC Power Harness Onto Disk Drive
- Install the SCSI Interface Harness Onto Disk Drive
- Mount the Disk Drive in Disk Module
- Reinstall SCSI ID Harness in Disk Module
- Secure Harness Cables in Disk Module
- Install Disk Module Cover



NOTE: Refer to the TranzPak 6 User Manual for details about system operations.

Internal Access

OPENING THE ZX STATION

One of the many design features of the ZX Station is the ease of access to the inside of the processing unit. To open the ZX Station in the rack, perform the following steps:



Be sure the power switches on the front and back are off. Disconnect all the cables from the back of the ZX Station to their respective units.



Remove the four ovalhead Phillips screws on the corners of the front panel and sliding the ZX Station all the way out.



Slide the ZX Station out until reaching the safety stop.



Remove the four pancakehead Phillips screws on the bottom of the ZX Station (upper two and lower right two).



Remove the six panhead Phillips screws on the sides of the top lid.



Remove the two pancakehead Phillips screws on the top front of the ZX Station lid.



Disconnect cables to components inside ZX Station.



Carefully lower the front panel.



The entire inside and back of the front panel of the ZX Station is now accessible.

CLOSING THE ZX STATION

To close the ZX Station, reverse the above steps:

Maintenance

CLEAN FRONT PANEL



WARNING: Be sure to turn off the power before performing any maintenance on the ZX Station

- Gently wipe the front panel of the ZX Station with a soft cloth.
- Remove finger marks and grease with a damp cloth and mild detergent. DO NOT use solvents or abrasives.
- Never use flammable cleaning material to clean the front panel of the ZX Station or other electrical apparatus.

Troubleshooting

FRONT PANEL

- Power light does not illuminate
- Check that power cable is properly connected to 110 vac power supply.
- Check that front panel power switch is on
- Check that power switch on back of ZX Station next to power plug is on.

ZX STATION CONFIGURATION

Because of the many configurations that the ZX Station can have with various combinations of components, visit the Z Microsystems Website for the latest Troubleshooting guidance.

www.zmicro.com

Specifications

The exact specifications may vary, depending on the combination of components ordered for the ZX Station.

Dimensions	7.00" H x 17.5" W x 19.0" D
Weight	24 lbs.
Power	90 - 132 vac or 180 - 264 VAC (switchable) 250 watts max. 175 watts typical
Operating temperature	10° C to 35° C (50 to 95° F)
Non-operating temperature	-20° C to +60° C (-4° F to 140° F)
Operating humidity	40% to 80% noncondensing
Non-operating humidity	30% to 90% noncondensing
Shock	TBD
Vibration	TBD
Electrical	UL 1950
EMI	FCC Class A
Mil-Spec	Additional extended range environmental military specifications can be met with optional enhancements.

Peripherals

Fixed Slot #1	Standard SCSI CD-ROM
Fixed Slot #2	Optional - choice of 5.25" Half-Height SCSI tape/disk
Fixed Slot #3	Standard -- 1.44 MB 3.5" Floppy Disk
Removable Slot	Optional - choice of Removable TranzPak disks/tapes

Appendix

WARRANTY

1 Year Extended Warranty

Extent of Limited Warranty

1. Z Microsystems, Inc. (Z Micro) warrants to the end-user that Z Micro products will be free from defects in materials and workmanship for a specified time after the date of purchase. The duration of this limited warranty is stated above. Certain additional conditions and limitations of Z Micro's warranty are stated in the User Guide. Those conditions and limitations include: For software products, the warranty applies only to the media upon which the product is recorded; and Z Micro does not warrant the operation of any product to be uninterrupted or error free.
2. Z Micro's limited warranty covers only those defects which arise as a result of normal use of the product, and do not apply to any: Improper or inadequate maintenance; Hardware add-in boards, software, or interfacing not supplied by Z Micro; Unauthorized modification or misuse; Operation outside the product's environmental specifications; or improper maintenance.
3. If Z Micro receives, during the applicable warranty period, notice of a defect in a hardware product which is covered by Z Micro's warranty, Z Micro shall either repair or replace the product, at its option. Any replacement product may be either new or like new, provided that it has functionality at least equal to that of the product being replaced.
4. If Z Micro is unable to repair or replace, as applicable, a defective product which is covered by Z Micro's warranty, Z Micro shall, within a reasonable time after being notified of the defect, refund the purchase price for the product, provided the product is returned.
5. This Limited Warranty Statement gives the customer specific legal rights. You may also have other rights which vary from state to state in the United States, from province to province in Canada, and from country to country elsewhere in the world.

Limitations of Warranty

1. NEITHER Z MICRO NOR ANY OF ITS THIRD PARTY SUPPLIERS MAKES ANY OTHER WARRANTY OF ANY KIND, WHETHER Z MICRO AND ITS THIRD PARTY SUPPLIERS SPECIFICALLY DISCLAIM THE IMPLIED WARRANTIES OF MERCHANTABILITY AND FITNESS FOR A PARTICULAR PURPOSE.
2. To the extent that this Limited Warranty Statement is inconsistent with the law of the locality where the customer uses the Z Micro product, this Limited Warranty Statement shall be deemed modified to be consistent with such local law. Under such local law, certain limitations of this Limited Warranty Statement may not apply to the customer. For example, some states in the

WARRANTY

United States, as well as some governments outside the United States (including provinces in Canada), may: Preclude the disclaimers and limitations in this Warranty Statement from limiting the statutory rights of a consumer (for example, Australia and the United Kingdom); Otherwise restrict the ability of a manufacturer to make such disclaimers or impose such limitations; Grant the customer additional warranty rights, specify the duration of implied warranties which the manufacturer cannot disclaim, or not allow limitations on how long an implied warranty lasts.

3. To the extent allowed by local law, the remedies provided in this Warranty Statement are the customer's sole and exclusive remedies.

Limitations of Liability

1. EXCEPT FOR THE OBLIGATIONS SPECIFICALLY SET FORTH IN THIS WARRANTY STATEMENT, IN NO EVENT SHALL Z MICRO BE LIABLE FOR ANY DIRECT, INDIRECT, SPECIAL, INCIDENTAL, OR CONSEQUENTIAL DAMAGES, WHETHER BASED ON CONTRACT, TORT, OR ANY OTHER LEGAL THEORY AND WHETHER ADVISED OF THE POSSIBILITY OF SUCH DAMAGES.

FAQ's --- Frequently Asked Questions

What equipment is covered?

Schedule A attached to the warranty statement that comes with the equipment lists the equipment covered.

What failures are covered?

Any type of workmanship or equipment **hardware failures** arising from **normal use** of the equipment is covered. Excluded are for problems related to abuse, acts of god, or acts of war. Software problems are not covered.

Who do I call?

Telephone or fax the Customer Service Dept. at Z Microsystems: **(858) 657-1000 x2 voice (858) 657-1001 fax** Please have the equipment serial number and a description of the problem ready when you call. It is also handy to know the version of the operating system you are using.

Appendix

WARRANTY

How long does it take?

Your equipment should be returned to you within 30 days of its receipt at the factory. In many cases it will be less (our goal is to have your equipment on its way back within 5 days). However, if the damaged equipment has to be serviced by the original manufacturer (Seagate, NEC, for example), it may take longer.

Are there any extra costs?

The only per incident cost you will incur is **Freight In** to return the equipment to the factory. Your extended warranty covers all of the costs associated with the repair and the return shipment of the covered equipment.

What about classified data?

Do not send any data storage equipment that contains classified material. There are no provisions for handling classified material.

Y2K COMPLIANCE

Z Microsystems has achieved full Y2K Compliance.

In late 1997, the company's senior management assigned a Y2K Project Team that consists of a cross-functional representation from information technology, procurement, manufacturing, test and development, finance, general affairs, engineering, marketing and facilities organizations to address the Year 2000 issues.

The Assessment/Rectification Phase of the Year 2000 efforts and full compliance for all mission critical internal systems were accomplished as scheduled by the end of Q1, 1999. Contingency development and validation of the company's overall Year 2000 readiness will continue through 1999.

The following strategically important categories have been assessed for Year 2000 readiness:

Suppliers and Service Providers Readiness.

All major strategic suppliers are assessed to be Year 2000 compliant. Most of the company's service providers' compliance efforts will continue through 1999. Major concerns and efforts will be focused on the company's shipping companies in 1999.

Z Microsystems Internal Systems

All mission critical internal systems are determined to be fully Year 2000 Compliant. A few minor Year 2000 related issues need to be addressed in 1999.

Z Microsystems Products

All Z Microsystems products are in full compliance.

The company's MIS has taken the lead and worked with the Finance Department to develop comprehensive Year 2000 Contingency Plans for the company's mission critical application systems to assure the continuity of daily business.

Support

FURTHER HELP

If you are unable to correct any problem yourself, contact:

Z Microsystems at:
(858) 657-1000
Fax: (858) 657-1001
Website: www.zmicro.com

Before calling, please have available as much of the following information as possible:

1. Model and serial number from the label on the monitor.
2. Purchase P.O.
3. Description of problem.
4. Computer type and model.
5. System configuration (hardware fitted, etc.).
6. System BIOS version number.
7. Operating System and version number.
8. Display driver version number.
9. Video Adapter type.



NOTE: If possible, stay by the computer. The Z Microsystems Technical Support Representative may wish to go through the problem over the telephone.



NOTE: More help, late-breaking news and details of the latest accessories for these products may be found on the worldwide web at: <http://www.zmicro.com>

REPLACING PARTS

If the Z Microsystems Technical Support Engineer determines that the product needs to be replaced, a Customer Service Representative will issue a Return Material Authorization (RMA) number and return address.

A RMA number is required to return a product to Z Microsystems, regardless of the reason for the return.

The following information is required when returning Z Microsystems products:

1. Model number
2. Serial number
3. Date of purchase
4. Proof of purchase (use the invoice or packing slip)
5. Customer ship-to address and any special shipping requirements
6. Specific and detailed description of the problem

PROVIDING FEEDBACK

We value your feedback on our products, their performance, any problems and constructive suggestions. Please send such productive information in writing to:

Customer Service
Z Microsystems
5945 Pacific Center Blvd., Suite 509
San Diego, CA 92121-4309
or www.zmicro.com



Z Microsystems, Inc.

5945 Pacific Center Blvd., Suite 509

San Diego, CA 92121

Phone: (858) 657-1000

Fax: (858) 657-1001

Website: www.zmicro.com

Copyright 1999 Z Microsystems, Inc. All Rights Reserved

Free Manuals Download Website

<http://myh66.com>

<http://usermanuals.us>

<http://www.somanuals.com>

<http://www.4manuals.cc>

<http://www.manual-lib.com>

<http://www.404manual.com>

<http://www.luxmanual.com>

<http://aubethermostatmanual.com>

Golf course search by state

<http://golfingnear.com>

Email search by domain

<http://emailbydomain.com>

Auto manuals search

<http://auto.somanuals.com>

TV manuals search

<http://tv.somanuals.com>