



WD Sentinel™ DX4000

Small Office Storage Server

Administrator's Guide



WD[®] Service and Support

Should you encounter any problem, please give us an opportunity to address it before returning this product. Most technical support questions can be answered through our knowledge base or email support service at <http://support.wdc.com>. If the answer is not available or if you prefer, please contact WD at the best telephone number shown below.

WD Guardian™ Services premium Technical Support and Extended Warranty services are also available for Small Business Customers. Contact WD Technical support at <http://support.wdc.com> for information about this extra level of support and how to obtain it.

Your product includes 30 days of free telephone support during the 3-year standard limited warranty period. This 30-day period starts on the date of your first telephone contact with WD Technical Support. Email support is free for the entire warranty period and our extensive knowledge base is available 24/7. To help us keep you informed of new features and services, remember to register your product on the Registration page on the user interface or online at <http://register.wdc.com>.

Accessing Online Support

Visit our product support website at <http://support.wdc.com> and choose from these topics:

- **Downloads** - Download drivers, software, and updates for your WD product.
- **Registration** - Register your WD product to get the latest updates and special offers.
- **Warranty & RMA Services** - Get Warranty, Product Replacement (RMA), RMA Status, and Data Recovery Information.
- **Knowledge Base** - Enter keyword, phrase, answer ID, or PID.
- **Installation** - Get manuals, installation guides, and documentation for your WD product.
- **WD Community** - Share your thoughts and connect with other WD users.

Contacting WD Technical Support

When contacting WD for support, have your WD product serial number, system hardware, and system software versions available.

North America		Europe (toll free)*	00 800 211 02110
English	855.556.5117		
Spanish	855.556.5117	Europe	+31 880062100
		Middle East	+31 880062100
Mexico	001 8002754932	Isreal	014 800 211 02110
		Africa	+31 880062100
		South Africa	00 800 211 02110
South America		Asia Pacific	
Chile	1230 020 5871	Australia	+1 800 42 9861
Venezuela	0800 100 2855	China	+ 00 800 211 02110
Peru	0800-54003	Hong Kong	+001 800 6008 6008
Uruguay	000 413 598 3787	India	+1 800 200 5789
Argentina	0800 4440839	Indonesia	+ 803 852 9439
Brazil	0021 0800 211 02110	Japan	001 800 211 02110 / 0033 800 211 02110 / 0061 800 211 02110
Columbia	009 800 211 02110	Korea	001 800 211 02110 / 002 800 211 02110
		Malaysia	+00 800 211 02110
		Philippines	00 800 211 02110
		Singapore	+ 00 800 211 02110
		Taiwan	+ 00 800 211 02110
		Thailand	+ 001 800 211 02110

* Toll free number available in the following countries: Austria, Belgium, Cyprus, Czech Republic, Denmark, Finland, France, Germany, Greece, Hungary, Iceland, Ireland, Italy, Luxemburg, Netherlands, Norway, Poland, Portugal, Slovenia, Spain, Sweden, Switzerland, United Kingdom.

Registering Your WD Product

Register your WD product to get the latest updates and special offers. You can easily register your product on the user interface of the product software or online at <http://register.wdc.com>.

Table of Contents

WD® Service and Support	ii
1 Important User Information	1
Important Safety Instructions	1
Handling Precautions	2
Recording Your WD Product Information	2
About This Guide	2
2 Product Overview	3
Getting to Know Your WD Sentinel DX4000 Server	3
Key Features	4
System Requirements and Compatibility Information	7
Technical Specifications	8
Product Views	9
Indicators	11
Where to Find Help	13
3 User Roles and Responsibilities	14
Types of WD Sentinel DX4000 Users	14
How the WD Sentinel DX4000 Fits into Your Office	15
4 Managing the WD Sentinel Server (Dashboard)	16
Setting up WD Sentinel Server & Connecting Computers	16
Accessing the Dashboard	16
Performing Dashboard Tasks	18
Using the Home Page	18
Managing User Accounts	20
Managing Computers and Backups	20
Managing Server Folders and Hard Drives	20
Monitoring Add-ins	21
Monitoring System Health and Alerts	21
Updating Software	24
Managing Server Settings	25
Shutting Down the Server	28
5 Managing Storage on the WD Sentinel Server	29
WD Sentinel Server RAID Storage	29
Using USB Storage	30

Replacing a Failed Drive	31
Adding Capacity by Adding a Drive	33
6 Using the WD Sentinel Server's Features	34
Using the Launchpad (Internal Users)	34
Accessing Shared Folders Over Your Network	40
Accessing Computers and Shared Folders Remotely	41
Backing up (Windows PC)	42
Backing up with Time Machine (Mac)	45
Recovering/Restoring (Windows PC)	48
Recovering/Restoring (Mac)	49
Recovering the WD Sentinel Server	50
7 Best Practices	60
Setting up the WD Sentinel DX4000	60
Setting up Client Computers	60
Using the WD Sentinel DX4000 Efficiently	60
Replacing Drives	61
Sharing Files with External Users	61
Shutting Down	61
8 Troubleshooting	62
First Steps Checklist	62
Specific Problems and Corrective Actions	62
9 Regulatory and Warranty Information	64
Regulatory Compliance	64
Limited Warranty	66
GNU General Public License ("GPL")	66
10 Appendix	67
Managing iSCSI Storage on the WD Sentinel Server	67
11 Glossary	72
12 Index	75

1

Important User Information

[Important Safety Instructions](#)
[Handling Precautions](#)
[Recording Your WD Product Information](#)
[About This Guide](#)

Important Safety Instructions

This device is designed and manufactured to assure personal safety. Improper use can result in electric shock or fire hazard. The safeguards incorporated into this unit will protect you if you observe the following procedures for installation, use, and servicing.

- Follow all warnings and instructions marked on the product.
- Unplug this product from the wall outlet before cleaning. Do not use liquid cleaners or aerosol cleaners. Use a damp cloth for cleaning.
- Do not use this product near any liquids.
- Do not place this product on an unstable surface. The product may fall, causing serious damage to the product.
- Do not drop the product.
- Do not block the slots and openings on the back or bottom side of the chassis; to ensure proper ventilation and reliable operation of the product and to protect it from overheating, these openings must not be blocked or covered. Making sure the server is standing upright also helps prevent overheating.
- Operate this product only from the type of power indicated on the marking label. If you are not sure of the type of power available, consult your dealer or local power company.
- Do not allow anything to rest on the power cord. Do not locate this product where persons will walk on the cord.
- If an extension cord is used with this product, make sure that the total ampere rating of the equipment plugged into the extension cord does not exceed the extension cord ampere rating. Also, make sure that the total rating of all products plugged into the wall outlet does not exceed the fuse rating.
- Never push objects of any kind into this product through the chassis slots as they may touch dangerous voltage points or short out parts that could result in a fire or electric shock.
- Unplug this product from the wall outlet and refer servicing to qualified service personnel under the following conditions:
 - When the power cord or plug is damaged or frayed.
 - If liquid has been spilled on the product.
 - If the product has been exposed to rain or water.
 - If the product does not operate normally when the operating instructions are followed. Adjust only those controls that are covered by the operating instructions since improper adjustment may result in damage and require extensive work by a qualified technician to return the product to normal condition.
 - If the product has been dropped or the chassis has been damaged.

- If the product exhibits a distinct change in performance, contact WD Customer Support at <http://support.wdc.com>.

WARNING! The WD Sentinel Server uses a lithium battery, type CR2032. There is danger of an explosion if the battery is incorrectly replaced. Replace only with the same or equivalent battery type recommended by the manufacturer. Dispose of used batteries according to the manufacturer's instructions.

Handling Precautions

WD products are precision instruments and must be handled with care during unpacking and installation. The WD Sentinel server may be damaged by rough handling, shock, or vibration. Be aware of the following precautions when unpacking and installing your external storage product:

- Do not drop or jolt the WD Sentinel server.
- Do not move the unit while it is powered on.
- Do not use this product as a portable drive.

Recording Your WD Product Information

Remember to write down the following WD product information, which is used for setup and technical support. Your WD product information is found on the label on the bottom of the device.

- Serial Number
- Model Number
- Purchase Date
- System and Software Notes

About This Guide

This Administrator's Guide provides detailed instructions and information for WD-specific interface elements and functions. Unless otherwise noted, refer to *Microsoft Online Help* for standard interface elements and functions.

This guide uses the following conventions:

Convention	Used for ...
Bold font	Names of items on a page such as menus, buttons, option names, fields, and tabs that the user must click or complete and keys the user must press.
Note:	Extra, but not vital, information
Important:	Essential Information to know or to prevent problems when using the WD Sentinel server
WARNING!	Vital information for operating the WD Sentinel server or to prevent damage to the server or your computer.

2

Product Overview

- [Getting to Know Your WD Sentinel DX4000 Server](#)
- [Key Features](#)
- [System Requirements and Compatibility Information](#)
- [Technical Specifications](#)
- [Product Views](#)
- [Indicators](#)
- [Where to Find Help](#)

Getting to Know Your WD Sentinel DX4000 Server

Congratulations on your purchase of the WD Sentinel DX4000 Small Office Storage Server.

Designed specifically for small business environments, WD Sentinel DX4000 is an easy-to-set-up Small Office Storage Server that provides secure centralized storage, complete data protection, and data access for your employees, clients, and vendors while in the office or working remotely from anywhere with an Internet connection. Featuring hardware and software from industry leaders, WD Sentinel DX4000 delivers a high performance, reliable, cost effective, and easy-to-manage storage server for your office network.

Offering complete data protection for your business, WD Sentinel DX4000 includes hard drives optimized for quality, reliability, and performance, support for RAID levels 1 or 5, backup and restore software for up to 25 computers, integrated block level data de-duplication for computer backups, dual Gigabit Ethernet ports, and an optional second power supply for high reliability and availability.

Note: RAID stands for Redundant Array of Independent Disks. RAID is a storage technology that provides increased reliability and data protection through redundancy.

The WD Sentinel server offers a full range of powerful features to put you in control to manage and protect your business data. It not only provides a central repository for all of your company information, but also as a backup server for up to 25 computers in your office network, without ever needing to purchase additional backup software licenses.

With its built-in secure Remote Web Access, your employees, local or working remotely, can collaborate with each other and securely access files and customer information, thereby improving productivity and efficiency.

Featuring four hot-swappable tray-less drive bays, WD Sentinel DX4000 provides a wide range of storage capacities, from 4 TB (2 TB usable in RAID 1 configuration) up to 16 TB (12 TB usable in RAID 5 configuration).

Key Features

Plug-and-play installation: The easy set up process allows you to integrate WD Sentinel into your office network like a pro. The administration dashboard quickly guides you through the process including adding users, setting up data access, creating shared folders, and scheduling backups.

Easy maintenance: Replacing one of the pre-installed drives, or adding a new drive, is as easy as changing a light bulb. Just open the door and swap out the drives. WD Sentinel does the rest. It seamlessly migrates the server to the appropriate RAID level

and automatically expands the server's storage capacity. Your users can still access your business data while the drive is being integrated. No data loss. No down time.

Comprehensive data protection for your entire office has never been easier.

- **The drives inside:** Pre-configured with hard drives optimized for reliability, quality and performance.
- **RAID:** Featuring levels 1 or 5 for data protection and speed.
- **Automatic backup and restore:** The software saves time and space by performing a full backup the first time and then automatically backing up only the data that has changed since the previous backup. In the event of a drive failure, WD Sentinel's easy restore function finds your files, restores them to their previous location and gets you up and running again quickly. The backup software also includes full metal backup.
- **Dual Ethernet ports:** Comes configured in Adaptive Fault Tolerance, which keeps your network available by automatically switching to the second Ethernet port if the first one should fail.
- **Optional dual power supply:** WD Sentinel DX4000 offers the small business owner the option of adding a second power supply that will take over should a power surge or other failure damage the first power supply. With the optional second power supply you have the added peace of mind knowing that your system will remain operational.

Secure remote access: WD Sentinel is perfect for businesses with employees working in satellite or home offices because you have the security of knowing all your business files are safely stored in one place and remote employees can access them from any computer with an Internet connection. WD Sentinel also performs automatic daily backups so all of the files on all the computers in your network are backed up and protected.

Leading-edge performance: With dual Gigabit Ethernet connectivity, WD Sentinel DX4000 delivers read/write speeds up to 100 MB/s through the Gigabit Ethernet interface. That's three times faster than most network drives in this category today. For maximum flexibility there is also a SuperSpeed USB 3.0 port to allow you to connect additional storage devices and experience up to 5Gb/s transfer rates.

A total solution with industry-leading technology partners

We combined hardware and software from industry leaders to deliver a reliable, secure and easy-to-manage storage server designed specifically for small office environments. WD Sentinel features:

- **Best-in-class hard drives** – Equipped with hard drives (2 TB, 3 TB, and 4 TB) that feature high capacity storage, peak performance and best-in-class reliability.
- **Intel® Atom® processor** - Built with the latest Intel Atom dual core processor inside, WD Sentinel DX4000 can easily handle your small business's day-to-day computing and file storage demands.

- **Windows® Storage Server 2008 R2 Essentials** –The tested Microsoft Windows Storage Server 2008 R2 Essentials operating system provides the cost effective, reliable, and scalable storage solution your small business needs to quickly and efficiently organize, protect, and share your critical business data using the familiar Windows user experience. With enterprise class, server-based, block level de-dupe backup capability you can be confident that your data is well protected.

LCD display panel readily offers critical information: The LCD display panel on the front of the device allows you to monitor the system status and critical alerts.

Real-time system status through the administration dashboard: View real-time updates for the system, RAID, and network status through WD Sentinel's dashboard, which includes easy-to-use task wizards to help you set backup schedules, administer user accounts, and manage public and private shares.

Compatible with multiple operating systems: Offers connector software support for Windows XP, Windows Vista®, and Windows 7. Also compatible with Mac OS X® Leopard®, Mac OS X® Snow Leopard®, Mac OS® X Lion*, or Mac OS® X Mountain Lion*. This cross-platform compatibility enables file sharing among Windows, Mac, and Unix/Linux operating systems.

Stream digital media anywhere in your network: With the built-in DLNA server your employees can access any shared media libraries on the network rather than maintaining copies on their individual computers. You can also stream digital content like videos, music, or digital signage for employees, vendors or clients using remote web access.

WD Guardian™ Services: When you need a little help from an expert, we'll take care of you! WD Guardian™ Services offers flexible, affordable and hassle-free technical support and extended warranty plans with a variety of benefits. Choose the plan that works best for your business. Visit www.wd.com for details.

Why WD?: Western Digital has been making hard drives for over 40 years. We know how to build drives to store and protect your data because we understand that your company's data is paramount to your business success.

Package Contents

- Small Office Storage Server
- 1 RJ-45 Ethernet cable
- AC adapter with power cord
- 2nd AC adapter with power cord(s) (with 16 TB model) available on some models
- Quick Install Guide

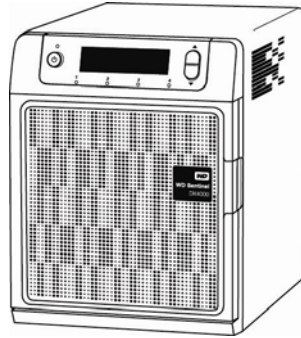

WD Sentinel DX4000

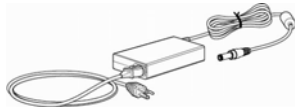

AC adapter
(2nd AC adapter for 16 TB Models)

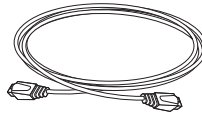

Ethernet cable



Quick Install Guide

For information on additional accessories, for example, a drive, additional power adapter, or Ethernet cable visit:

US	www.shopwd.com or www.wdstore.com
Canada	www.shopwd.ca or www.wdstore.ca
Europe	www.shopwd.eu or www.wdstore.eu
All others	Contact WD Technical Support in your region. For a list of Technical Support contacts, visit http://support.wdc.com and see Knowledge Base Answer ID 1048.

System Requirements and Compatibility Information

Requirement	Description
Client Operating System Compatibility	<p>Windows 7</p> <ul style="list-style-type: none"> • Home Basic (x86 and x64) • Home Premium (x86 and x64) • Professional (x86 and x64) • Ultimate (x86 and x64) • Enterprise (x86 and x64) • Starter (x86) <p>Windows Vista</p> <ul style="list-style-type: none"> • Home Basic with Service Pack 2 (SP2) (x86 x64) • Home Premium with SP2 (x86 and x64) • Business with SP2 (x86 and x64) • Ultimate with SP2 (x86 and x64) • Enterprise with SP2 (x86 and x64) • Starter with SP2 (x86) <p>Windows XP</p> <ul style="list-style-type: none"> • Home with Service Pack 3 (SP3) • Professional with SP3 • Media Center 2005 with SP3 <p>Mac OS X</p> <ul style="list-style-type: none"> • Leopard® • Snow Leopard® • Lion™ * • Mountain Lion™ * <p>* For Mac OS X Lion and Mountain Lion, ensure that your WD Sentinel server has the latest software updates from Microsoft and Western Digital.</p>
Local Network	<ul style="list-style-type: none"> • Router/switch (Gigabit Ethernet recommended to maximize performance) • DHCP enabled
Broadband Access	Required for remote access outside the LAN

Technical Specifications

Specification	Description
Interfaces	<ul style="list-style-type: none"> High performance (10/100/1000) Gigabit Ethernet connection 2 ports of powered USB 3.0
I/O ports	<ul style="list-style-type: none"> 2 Ethernet (RJ-45 Ports) 2 USB 3.0 Ports
Supported protocols	CIFS/SMB, NFS, HTTP, HTTPS, WebDAV
Internal hard drives	<p>2-4 WD 3.5-inch SATA RAID Edition hard drives with RAID-specific time-limited error recovery (TLER) Pioneered by WD, this feature prevents drive fallout caused by the extended hard drive error-recovery processes common to desktop drives.</p> <p>Improved rotary vibration tolerance Optimized drive mechanics, system characterization, and process validation yield unmatched performance in high vibration environments.</p> <p>Approved Drive Models For a complete list of approved drive models, search for Answer ID 9443 in the WD Knowledge Base at http://support.wdc.com.</p>
CPU	Intel Atom Dual Core 1.80 Ghz
Memory	2 GBytes SODIMM DDR3-800
Drive bays	<ul style="list-style-type: none"> 4 3.5 inch hard drive bays Hot swap capable Trayless design
RAID level	<ul style="list-style-type: none"> RAID 1 (2 drives only) and RAID 5 (3-4 drives) Automatic migration and capacity expansion
Physical dimensions	<ul style="list-style-type: none"> Length: 6.3 inch (160 mm) Width: 8.8 inch (224 mm) Height: 8.1 inch (206 mm)
Weight	<ul style="list-style-type: none"> 4 TB and 6 TB: 10.76 lb (4.88 kg) 8 TB and 12 TB: 14.0 lb (6.35 kg) 16 TB: 13.51lb (6.13 kg) 16 TB (EMEA): 14.51 lb (6.58 kg)
Capacities	4 TB, 6 TB, 8 TB, 12 TB, 16 TB
Power	<ul style="list-style-type: none"> 2 external power ports Redundant failover
Power supply	<ul style="list-style-type: none"> Input voltage: 100 to 240 V AC Input frequency: 50 to 60 Hz Output voltage: 19V DC, up to 6.32A
Temperature	<ul style="list-style-type: none"> Operating temperature: 5 to 35 °C (41 to 95 °F) Non-operating temperature: -20 to 65°C (-4 to 149 °F)
Switches	<ul style="list-style-type: none"> Power Buttons for scrolling through messages on LCD

Specification	Description
LEDs	<p>1 Power LED</p> <ul style="list-style-type: none"> Flashing blue indicates boot status Flashings red indicates a fault condition Solid blue once booted, and there are no pending fault conditions, indicates a good operational state <p>4 Drive Bay LEDs</p> <ul style="list-style-type: none"> Flashing blue or solid blue indicates drive activity Solid RED indicates drive fault. (Drive must be replaced)
LCD panel	2 lines of 16 characters for status and alerts
Operating System	Windows Storage Server 2008 R2 Essentials
Backups	25-client computer support for backup (server based)
Recovery	<ul style="list-style-type: none"> Bare metal restore File/folder level restore

Product Views

Front View

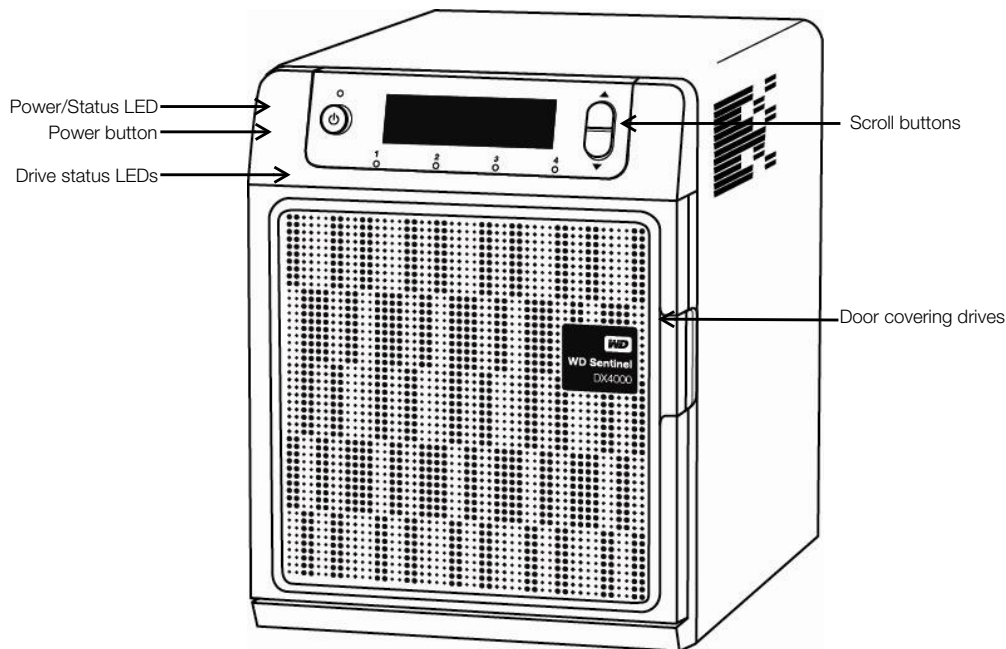

Back View

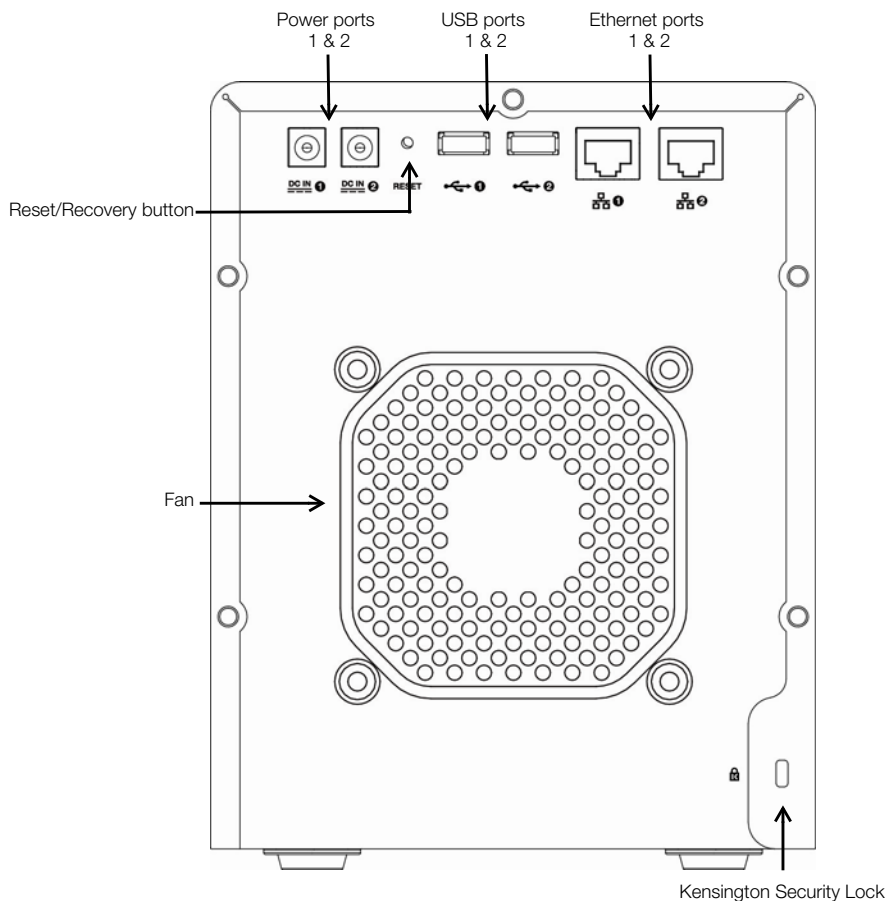

Component	Icon	Description
Ethernet ports		Connect the device to a local network.
Power ports		Connects the device to an AC adapter and the power outlet.
Reset /Recovery button		Button on the back of the server recovers the server (including the operating system) while using a USB drive in an event of an OS corruption.
USB ports		Connects with USB 2.0 or 3.0 devices such as a USB storage or a UPS.

Indicators

LCD

The Liquid Crystal Display (LCD) on the front of the WD Sentinel server is a portal into its status. Normally, the LCD displays the name of the WD Sentinel server that the administrator assigned during initial setup along with its IP address. You can use either of these to discover and communicate with the server. (See the Quick Install Guide for Administrators.)

Use the scroll buttons to the right of the LCD to display:

- Number of drives that are installed
- Available capacity
- Status

If an alert occurs, or the WD Sentinel server is performing certain operations, the following status displays in the LCD:

Alert	Description
Backup Failed	The server failed to back up a computer. Go to the Dashboard and examine the alerts to discover which computer backup failed and why.
Capacity Low	Available storage capacity of the WD Sentinel server is low.
Drive Overtemp	The temperature of one of the drives is too high.
Ethernet 1 Disconnected	WD Sentinel server has detected that Ethernet 1 has lost connection.
Ethernet 2 Disconnected	WD Sentinel server has detected that Ethernet 2 has lost connection.
Fan Failed	WD Sentinel server has detected that the fan is no longer operational.
Imminent Drive Failure	One of the drives is demonstrating imminent failure (discovered through Self-Monitoring Analysis and Reporting Technology S.M.A.R.T). Replace the drive as soon as possible.
Initializing	The RAID system is initializing the storage; this is similar to Verifying.
Invalid Drive	A drive that is not approved for use in the WD Sentinel server has been inserted.
Invalid Drive Capacity	A drive with incompatible size was inserted and migration/rebuild could not proceed.
Migrating ... %	RAID system is migrating to a larger capacity due to the addition of a drive.
Network Disconnected	The server is not connected to the network.
Power Supply 1 Failed	Power supply 1 has failed or been disconnected.
Power Supply 2 Failed	Power supply 2 has failed or been disconnected.
Reboot	WD Sentinel server will reboot.
Repairing ... %	RAID system is being repaired to full RAID protection.
Shutting Down	WD Sentinel server is shutting down.
Software Update Available	A WD Sentinel server update is available. Using the Dashboard, apply the update.
Storage Degraded	RAID protection is no longer in place, and a drive needs to be replaced.
Temperature High	WD Sentinel server has exceed acceptable temperature and will shut down.
Verifying ... %	RAID system was shut down inadvertently. It is validating and correcting the integrity of the RAID array.

LEDs

The LEDs on the Sentinel work in conjunction with the LCD display to further identify the status of the unit.

LED	Color	State	Description
Power LED	Blue	Flashing	WD Sentinel server is currently booting the software.
	Blue	Solid	WD Sentinel server has successfully booted the software and is operational.
	Red	Flashing	Indicates that a serious fault has occurred and needs immediate attention. The LCD displays the fault condition.
Drive LEDs	Black	Off	If the LED is off while other drive LEDs are on, no drive is installed in the bay.
	Blue	Flashing	Drive is currently active. Note that all lights in a RAID system are active at the same time by design.
	Red	Solid	Indicates drive failure. The LCD also displays "Storage Degraded." Replace this drive as soon as possible. The system is no longer RAID protected until the drive is replaced and the RAID structure is repaired.
Ethernet Port Left LED (on back of server)	Green/Amber	Solid	The left LED indicates the connection speed of the network connection: <ul style="list-style-type: none"> Green indicates a 1000 Mb connection Amber indicates a 100 Mb connection
Ethernet Port Right LED (on back of server)	Green	Blinking	Indicates link activity.

Where to Find Help

This manual provides step-by-step instructions and other important information regarding your WD product. It is meant for the person serving as the administrator of the WD Sentinel DX4000. You can download translated versions and updates to this manual from <http://products.wdc.com/updates>. For more information and news about this product, visit our website at <http://www.wdc.com/>.

Additional Reference	Description
Quick Install Guide for Administrators	Included in the product box or available at http://products.wdc.com/WDSentinel/ ; helps you install the WD Sentinel server and gets you started using it.
WD Online Help	Specific descriptions and instructions accessed on WD-specific (Monitor) pages on the Dashboard.
Microsoft Online Help	<ul style="list-style-type: none"> • Access detailed explanations and instructions for a particular page by clicking the Help button  at the top right of the Dashboard. • Search for help on a specific topic or term by entering it in the Microsoft Online Help search field at the top right of the page. • Access the entire Microsoft Online Help system by clicking Microsoft Online Help.

Important: Not all Microsoft Online Help is applicable to the WD Sentinel DX4000. The WD Online Help and this Administrator's Guide take precedence over the Microsoft Online Help.

3

User Roles and Responsibilities

[Types of WD Sentinel DX4000 Users](#)

[How the WD Sentinel DX4000 Fits into Your Office](#)

This chapter reviews how the WD Sentinel server fits into your office and delineates the tasks for which the Administrator and Users have responsibilities.

Types of WD Sentinel DX4000 Users

At a high level there are two categories of users who need to access one or more features of your WD Sentinel server.

- **Administrator**—This is the person who performs the setup and routine management tasks on the WD Sentinel server. This person is also the holder of the Administrator password of your WD Sentinel server.
- **Users**—You can have up to 25 user accounts on your WD Sentinel server. These can be:
 - **Internal Users** – The internal users are typically the employees (including the Administrator) in your office, working locally or occasionally from a remote location (e.g. Sales Staff), who need to access business data and server resources.
 - **External Users** – The external users are the customers and business partners with whom you need to exchange business data.

The WD Sentinel server offers different paradigms for each type of user. The table below provides a view into the usage model and tasks for each category of users.

Administrator (e.g., Business Owner)	Internal Users (e.g., Employees)	External Users (e.g., Clients or Business Partners)
Primary Setup Tasks <ul style="list-style-type: none"> • Physically connects the WD Sentinel server to the network. • Configures the WD Sentinel server itself. This is a one-time procedure. • Connects a Windows PC to the WD Sentinel server by installing Connector software on it. 	Primary Setup Tasks <ul style="list-style-type: none"> • None 	Primary Setup Tasks <ul style="list-style-type: none"> • None
Primary User Interface <ul style="list-style-type: none"> • Dashboard - Signs in using the Administrator password (no username required). 	Primary Interface <ul style="list-style-type: none"> • Launchpad - Signs in using the assigned user name and password. Secondary Interface <ul style="list-style-type: none"> • Remote Web Access - While accessing remotely, signs in using the assigned user name and password. 	Primary Interface <ul style="list-style-type: none"> • Remote Web Access - Signs in using the assigned user name and password.

Administrator (e.g., Business Owner)	Internal Users (e.g., Employees)	External Users (e.g., Clients or Business Partners)
<p>Dashboard Task Examples</p> <ul style="list-style-type: none"> • Sets up user accounts and assigns permissions. • Manages shared folders. • Sets up and manages automatic backup schedule. • Manages WD Sentinel server settings, resolves any alerts, and monitors server performance. • Sets up Remote Web Access. • Manages updates. • Creates and manages iSCSI targets. 	<p>Launchpad Task Examples</p> <ul style="list-style-type: none"> • Accesses data on shared storage. • Starts manual backups. • Launches Remote Web Access. <p>Remote Web Access Task Examples</p> <ul style="list-style-type: none"> • Accesses data on shared storage. • Connects to the PCs in the office remotely. • Accesses media library. 	<p>Remote Web Access Task Examples</p> <ul style="list-style-type: none"> • Accesses data on shared storage. • Accesses media library.
<p><i>Note:</i> For each user account, the WD Sentinel server enables the Administrator to set granular permissions for various shared folders as well as server resources, such as Remote Web Access. At all times, the users are only able to access the data on the server and other server resources for which they have permissions.</p>		

How the WD Sentinel DX4000 Fits into Your Office

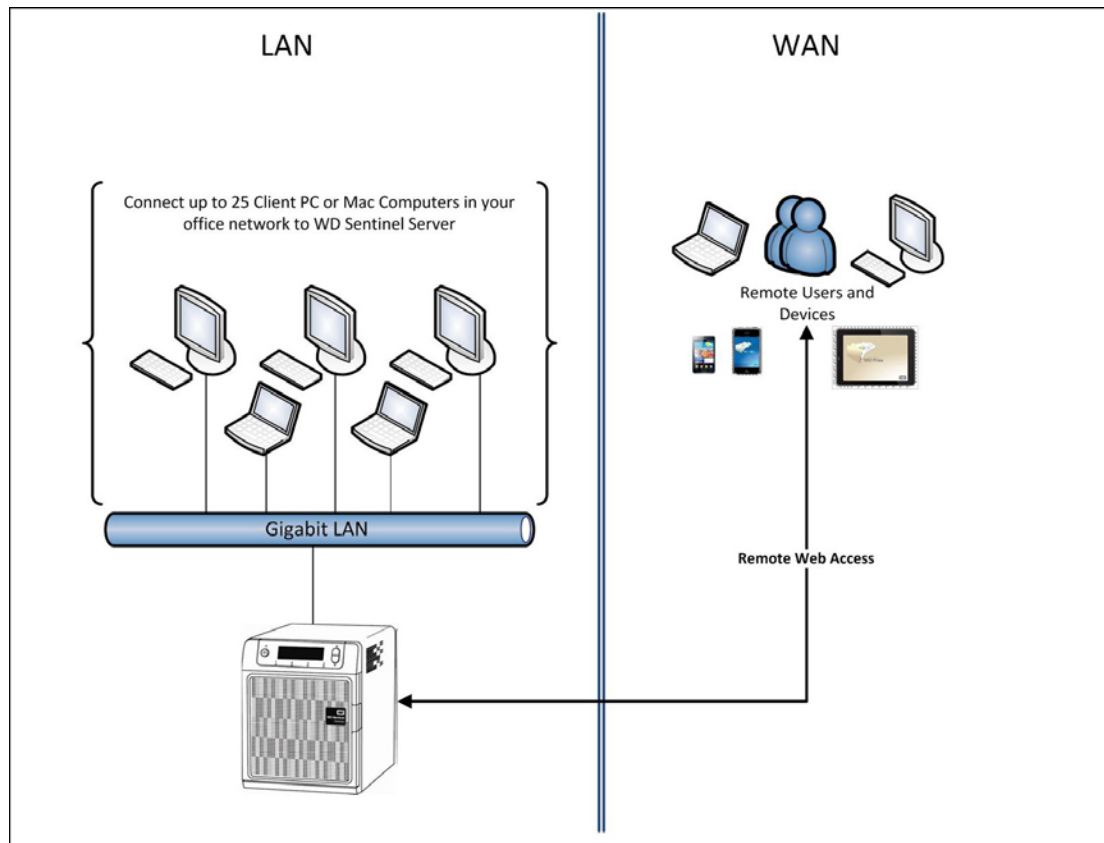

4

Managing the WD Sentinel Server (Dashboard)

- Setting up WD Sentinel Server & Connecting Computers
- Accessing the Dashboard
- Performing Dashboard Tasks
- Using the Home Page
- Managing User Accounts
- Managing Computers and Backups
- Managing Server Folders and Hard Drives
- Monitoring Add-ins
- Monitoring System Health and Alerts
- Updating Software
- Managing Server Settings

Setting up WD Sentinel Server & Connecting Computers

This chapter assumes you have followed the Administrator's Quick Install Guide to initialize the WD Sentinel server and connect computers, and that you are familiar with the Dashboard and Launchpad. To review the setup steps, please see the hard copy guide that came in the box, or access the soft copy at <http://products.wdc.com/wdsentinel>.

Accessing the Dashboard

To access the Dashboard (Windows):

1. Click **Start** or  > **(All)Program(s) >Windows Storage Server 2008 R2>Windows Storage Server 2008 R2 Dashboard**.
2. On the Dashboard Sign in page, enter the Administrator password (created during setup) and click the **right arrow**:



To access the Dashboard (Mac):

1. In the Application folder, select **Windows Server Dashboard**.

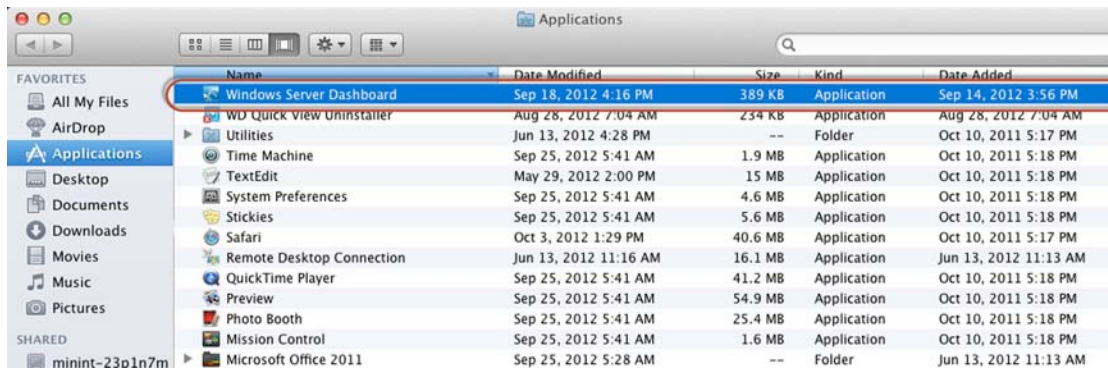

2. For first time sign-in, enter the server IP address (found on the LED display of your server) and the Administrator password (created during setup).
3. Enter the following information on the Remote Desktop Connection screen:
 - **User Name:** Enter **Administrator**.
 - **Administrator Password:** The password you created during setup.
 - **Computer Name:** The server name you created during setup.

The Dashboard appears:

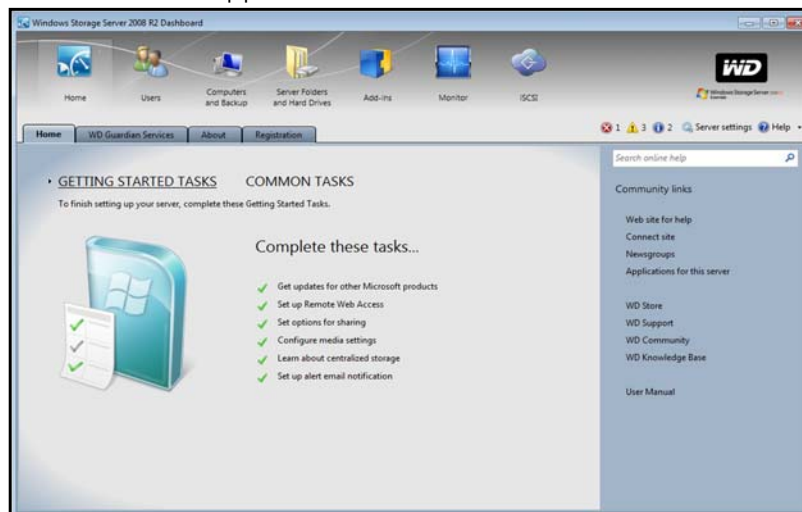

The Dashboard Home page displays:

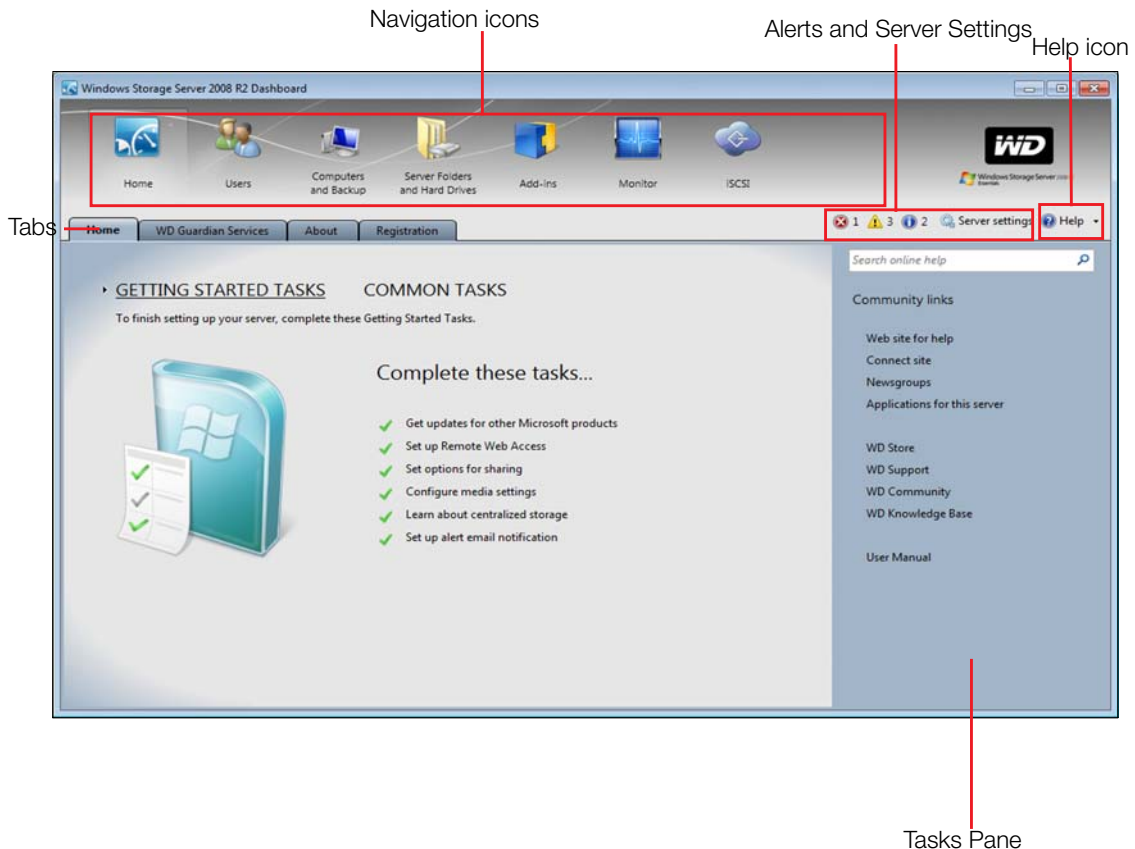

Performing Dashboard Tasks

The Administrator uses the Dashboard to perform administrative tasks such as creating user accounts, setting up access privileges to shared folders and other server resources, managing shared folders, and monitoring the WD Sentinel server.

For information about an additional task, backing up a computer to the WD Sentinel server, see “Backing up (Windows PC)” on page 42.

Using the Home Page

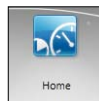

The main part of the Home page lists some of the recommended tasks to perform the first time you sign in to the Dashboard. To perform these tasks from the Home page, just click the relevant links. The panel on the right offers easy access to the WD Sentinel DX4000 community and to WD resources. The rest of this chapter discusses the tasks the Administrator can perform on the Dashboard.

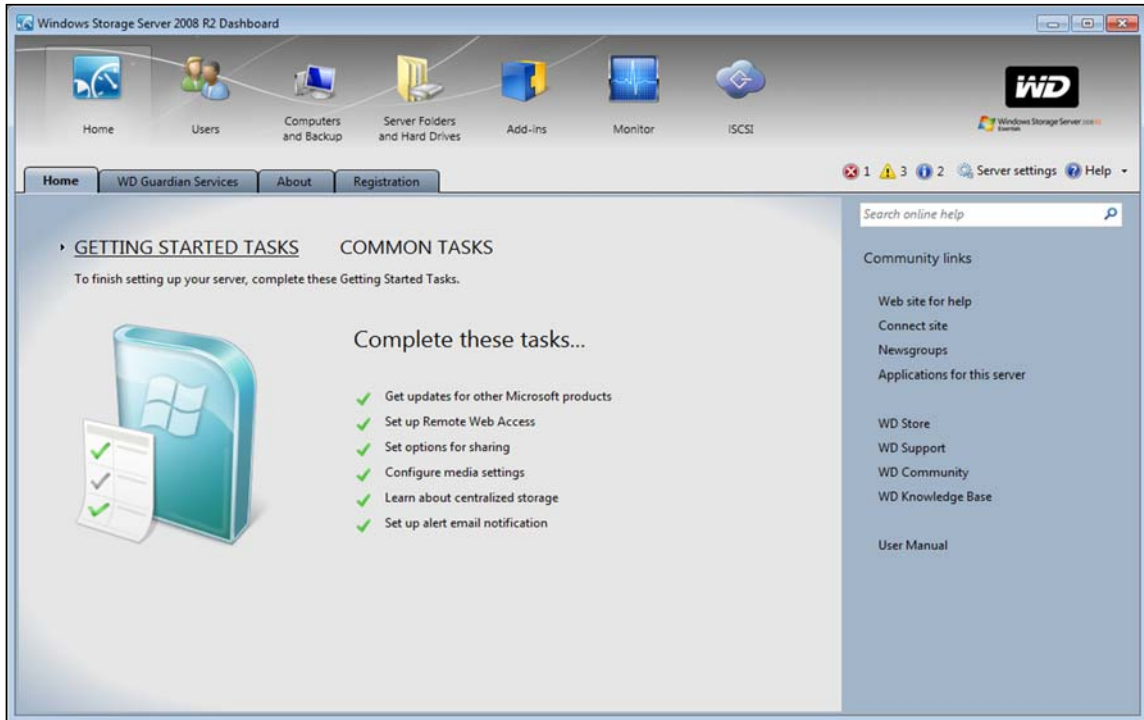

For a full description of the typical components of a page, including the Critical, Warning, and Informational Alert icons, see the [Microsoft Online Help](#).

Home Page Tabs

The Home page contains four tabs, summarized below:

Tab	Description
<p>Home</p>	<p>Complete basic tasks that will get you started with the WD Sentinel server. For information about these tasks, see the Microsoft Online Help.</p> <p>Best Practices:</p> <ul style="list-style-type: none"> • Complete the Getting Started tasks on the Home page of the Dashboard. • Create at least one active user account the first time you access the Dashboard.
<p>WD Guardian Services</p>	<p>Western Digital offers WD Guardian Services for Small Business customers. Choose from various technical support plans and extended warranty services that work best for your business. For more information, visit http://www.wdc.com.</p>
<p>About</p>	<p>Displays basic information such as product serial number, IP address, and software version.</p>
<p>Registration</p>	<p>Allows you to register your server with WD. Once registered you will receive notifications of product and firmware updates, newsletter, information about new product, and services as well as periodic special offers from WD. Enter the required information and click Register. Optionally, enter the Partner ID of the WD Partner who helped you purchase or install your WD Sentinel server.</p>

Home Page Tasks Panel

In the panel on the right of the Home page displays links to useful WD websites and resources to make the best of your WD Sentinel server.



Managing User Accounts

On the navigation bar, click the **Users** icon. You can now:

- View, add, manage, delete, and activate/deactivate user accounts.
- Use the guest account
- Manage domain user accounts
- Manage passwords
- Manage Remote Web Access
- Assign user access privileges to shared folders and server resources

For detailed instructions on performing any of these tasks, consult [Microsoft Online Help](#).



Managing Computers and Backups

After you've connect your computers to the Windows Storage Server 2008 R2 Essentials network, you can manage the computers from a central location in the Computers and Backup section of the Dashboard including.

- Viewing a list of computers connected to your server.
- Viewing computer properties and health alerts for each connected computer.
- Setting up and managing computer backups.
- Restoring files and folders to computers.

For detailed instructions on performing any of these tasks, consult [Microsoft Online Help](#).



Managing Server Folders and Hard Drives

The WD Sentinel DX4000 contains two tabs:

- The **Server** tab allows you to view and manage the properties of the shared folders on your server including:
 - Managing your company's shared folders
 - Accessing shared folders locally or remotely
 - Uploading or download files locally or remotely
- The **Hard Drives** tab allows you to view and check the health of the drives that are attached to your server.

For detailed instructions on performing any of these tasks, consult [Microsoft Online Help](#).



Monitoring Add-ins

The Add-ins section of the Windows Storage Server 2008 R2 Essentials Dashboard includes tasks that help you view and manage the Add-ins that are installed on the server.

For detailed instructions on monitoring add-ins, consult [Microsoft Online Help](#).



Monitoring System Health and Alerts

The Monitor module of the Dashboard includes tasks that help you view and manage the WD Sentinel server storage system. To open the Monitor module, click the **Monitor** icon on the navigation bar. The Monitor module includes two tabs, **Health** and **Software Update**, and related tasks in the panel on the right.

Health Tab

The **Health** tab and related tasks enable you to monitor the status of the storage drives, RAID configuration, power supplies, temperatures, fans, CPU, and network connections.

To open the **Health** tab, click the **Monitor** icon on the navigation bar:

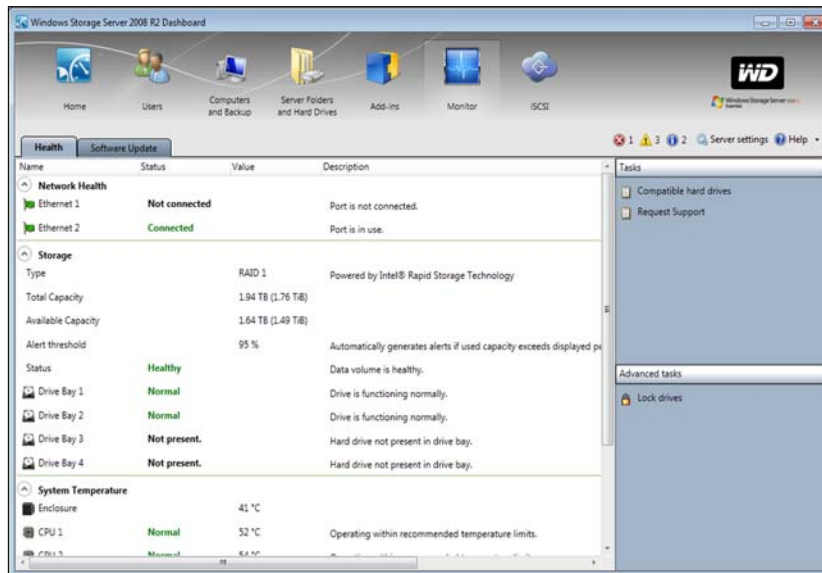

Settings	Description
Network Health Ethernet 1 & 2	Displays the status (Connected or Not connected) of the server's network connection(s). If you use both Ethernet ports and one fails, the other takes over, allowing the WD Sentinel server to remain operational over the network.

Settings	Description
Storage	<p>Displays storage information associated with the WD Sentinel server. The WD Sentinel server holds up to four of WD's hard drives optimized for quality, reliability and performance and features RAID levels 1 or 5 to enhance performance and data protection.</p> <p>RAID is an acronym for Redundant Array of Independent Disks. With two drives installed, the WD Sentinel server uses RAID 1 (mirror). With three or four drives installed, the server uses RAID 5, which offers fast performance by striping data across all drives. This arrangement protects data by dedicating a quarter of each drive to fault tolerance, leaving three quarters of the system capacity available for data storage.</p> <p>Type: RAID level</p> <p>Total Capacity: Maximum amount of storage space (TB) available.</p> <p>Available Capacity: Amount of storage (TB) left available for use.</p> <p>Alert Threshold: The percentage of storage capacity used above which you receive alert notifications that the storage is approaching maximum threshold.</p> <p>Status: The status of the server storage may be:</p> <ul style="list-style-type: none"> • Healthy–All drives are in the optimal state. • Degraded–A single drive failed; data is protected, but performance is degraded. (A failed drive must be replaced with a healthy drive as soon as possible to fully protect your server and data.) <p>Status of drives 1-4: The status of a drive may be:</p> <ul style="list-style-type: none"> • Normal • Failed!: Visit WD Store to replace. <p>CAUTION: Imminent failure detected. Please replace this hard drive immediately.</p>
System Temperature	<p>Enclosure: The temperature within the server enclosure.</p> <p>CPUs 1 & 2: The Temperature, status, and status description for each CPU. (The server does not have two physical CPUs but instead uses a dual core CPU. CPU 1 and CPU 2 represent the details for each core.) The status may be:</p> <ul style="list-style-type: none"> • Normal • Warm • Hot
Cooling Fans	<p>The status of the server's cooling fan may be:</p> <ul style="list-style-type: none"> • Active • Inactive <p>Speed of revolutions in RPMs.</p>
Power Supplies 1 & 2	<p>The server has two power supplies. If you use both and one fails, the other takes over and the WD Sentinel server remains operational. The status may be:</p> <ul style="list-style-type: none"> • Active • Inactive

Health Tasks

Find compatible hard drives

To view a list of WD drives that can be used in the WD Sentinel server:

1. Click **Compatible Hard Drives** in the Task pane. A pop-up screen lists each drive with its model number, description, and maximum capacity.
2. If desired, click the **WD Store** button to view or buy additional drives.
3. To exit, click **OK**.

Request Support

The Request Support function collects information about your WD Sentinel and sends a diagnostic report to the WD Support server. It then opens the WD Support website, where you can enter a few details regarding the problem to route it to the appropriate support team.

Note: If you do not want to submit the diagnostic logs, use the regular WD Support page at <http://support.wdc.com>.

To access WD Customer Support automatically:

1. Click **Request Support** in the Tasks pane. The Request Support window displays.
2. After reading the information on the screen, click the "I agree and would like to proceed." checkbox, then click Proceed. The WD Support Ask a Question page displays.

Note: The first time you do this, an Internet Explorer Security Screen displays. Clear the check box and click **Close**.

3. Complete the online form and click **Submit Question**. A diagnostic report of the WD Sentinel server is automatically attaches to the form. Your request is added to the WD Support queue and assigned a confirmation number. You will receive an email from WD Support regarding your question.

Important: For faster service/phone service, call WD Support. For the latest phone numbers and contact information in your region, see "Contacting WD Technical Support" on page ii or <http://support.wdc.com>. Have your confirmation ready when you call.

Lock/Unlock

For security reasons, you can lock or unlock the drives. You cannot lock or unlock an individual drive; you either lock them all or unlock them all, using a password you create here. This password may be but does not have to be the same as the WD Sentinel server Administrator password.

Important: Store your password in a secure place. If the password is lost, there is no way to get it back or unlock the drives, and all of its data may be lost.

To lock the drives:

1. Click **Lock drives**.
2. In the New Password field, Enter your password.
3. In the Confirm Password field, confirm your password,
4. In the Password Hint field, enter a hint to remind you of the password.
5. Click **OK**.

To unlock drives:

1. Click **Unlock drives**.
2. In the Old Password field, enter your password.
3. Click **Unlock drives**.

To change the password:

1. Click **Unlock drives**.
2. In the Old Password field, enter the current password.
3. In the New Password field, enter your new Password.
4. In the Confirm Password field, confirm your new password
5. In the Password Hint field, enter a hint to remind you of the password.
6. Click **OK**.

Updating Software

Periodically, WD issues software updates for your WD Sentinel DX4000 server. When a software update is available, the LCD on your WD Sentinel displays the following message: **Software updates available**. The Software Update tab within the Monitor module allows you to update WD Sentinel DX4000 software automatically or manually. Please note that this tab only allows you to apply software updates issued by WD. To manage or apply Microsoft software updates, go to **Server Settings** on the Dashboard.

Manual Updates of WD Software

To check for software updates and update the software:

1. Click the **Software Updates** tab.

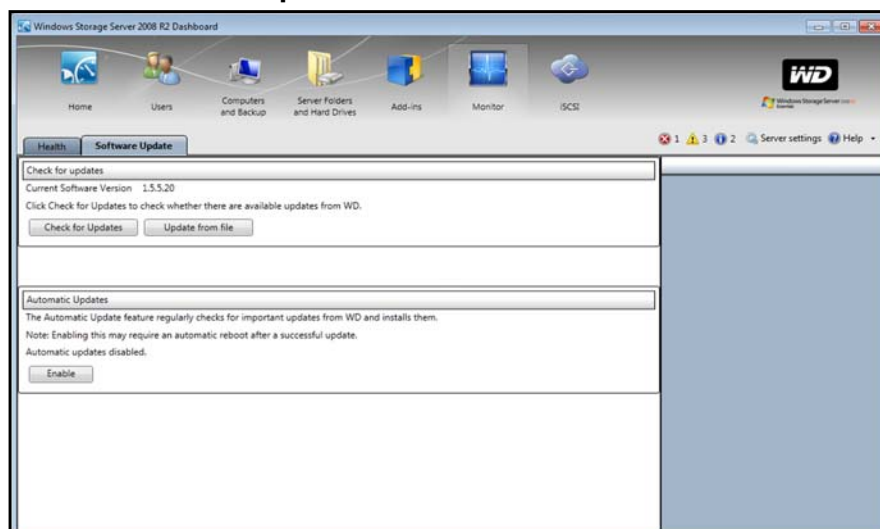

2. You have two options. You may check for updates online or update from a file:

To use the online update:

- a. Click **Check for Updates**.
- b. If an update is available, click **Download** and **Install** to update your WD Sentinel server.

To update from a file:

- a. The software update files can also be downloaded from the WD Support site at <http://support.wdc.com>. Once you download the available firmware updates for the WD Sentinel DX4000 server, copy the file to a shared folder such as the Documents share on the server and select the file to update.
- b. Click **Update from file** and then locate and select the update file you copied to your server.
- c. Click **Open**. The system applies the software update. The system automatically restarts the server if a reboot is required to complete the software update.

Automatic Updates of WD Software

Enabling **Automatic Updates** on your WD Sentinel server causes the server to check for available software updates from WD on a scheduled basis and apply the updates automatically.

To set a schedule for automatic updates:

1. In the **Automatic Updates** section, click **Enable**.



2. Click the **Change** link and select the day and time you want the WD Sentinel server to check for updates every week, and if an update is available, install it. (Example: every Sunday at 3:00 AM)
3. Click **Apply**.

Updating Microsoft Software

You can update the Microsoft software for the WD Sentinel DX4000 using the Server Settings page. See “Managing Server Settings,” below.

Managing Server Settings

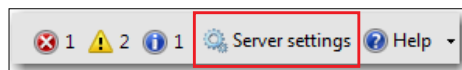

Important: Unless otherwise noted, [Microsoft Online Help](#) provides complete instructions for using these pages.

1. Click **Server Settings** on the icon bar to enable, set up, and control WD Sentinel server settings.

2. The General page displays. The left panel contains links to the rest of the Server Settings pages.

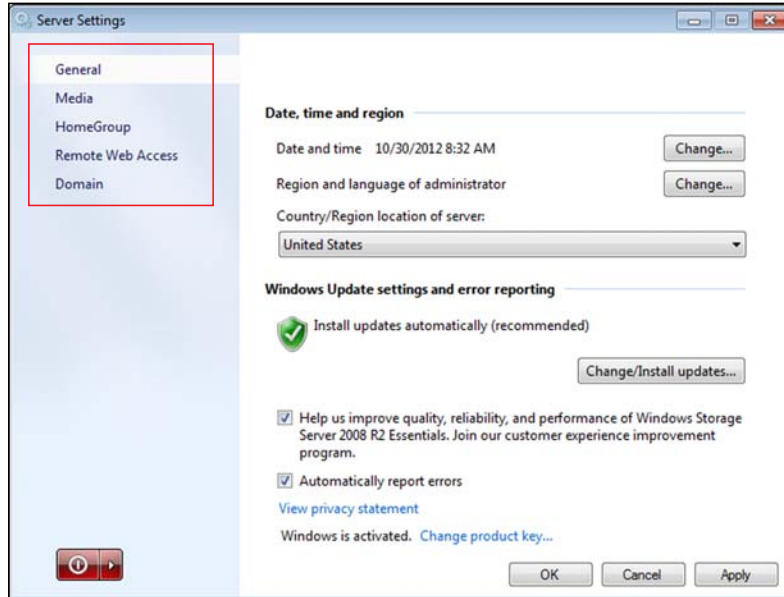

Following is a summary of the purpose of each of the Server Settings pages.

General

- **Shutdown or restart the server**—This is the safest method to shut down or restart the server. It insures that the RAID system shuts down cleanly. See “” on page 27 for instructions.
- **Change the date, time, and location of the server**—You can change the settings you established at initialization.
- **Change the behavior of the Microsoft update**—You can change the settings for updating the Microsoft software.

Media

Enable or disable media (DLNA) services, set the video streaming quality, and define the folders to be used for the media. By default, media service is enabled, and the default Picture, Music, and Video folders are set to distribute the media.

HomeGroup

When creating a HomeGroup, establish which folders are to be shared through the HomeGroup. Note that HomeGroup is only available for Windows 7 clients.

Remote Web Access

With Remote Web Access enabled, you can access the WD Sentinel server from any device using a web browser, such as Internet Explorer, from anywhere with Internet access. You can access shared folders and files (that you have permission for) on the server as well as on your networked computer.

Enabling Remote Web Access

Enable or disable Remote Web Access on the Server Settings page. Remote Web Access is turned off by default.

Note: The Home page provides a Getting Started task for enabling Remote Web Access by clicking link to the process.

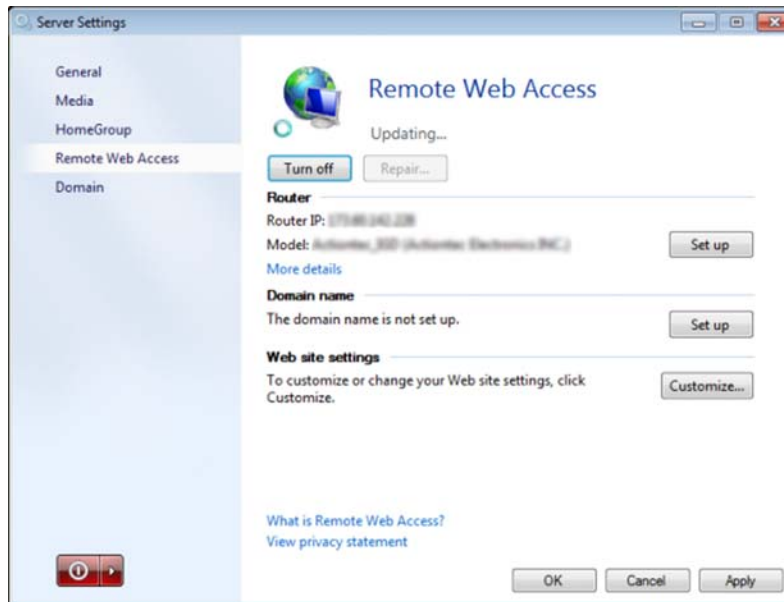

1. Under **Server Settings**, click **Remote Web Access** in the panel on the left.
2. Click **Turn on** and complete the wizard to set up your router, set a domain name, and change Internet settings.
3. Grant Remote Web Access privileges if you want a user to access the WD Sentinel server, shared folders, computers, media, Home page links, and the Dashboard (administrators only) when you create or update a user account.

To view a user's current privileges, click the **Users** icon in the Navigation bar.

Note: The Guest account cannot have Remote Web Access.

Note: Refer to [Microsoft Online Help](#) for detailed information about setting up remote web access and for troubleshooting connection issues.

Domain

This option is available for networks that have an Active Domain server for user control. A domain is a group of computers under the control of a server known as the domain controller. In the case of the Sentinel DX4000, it enhances security by allowing only users with necessary permissions to access the server. Refer to [Microsoft Online Help](#) for detailed information. For information on acceptable domains, go to <http://support.wdc.com> and search for Knowledge Base Answer ID 8549.

Shutting Down the Server

The WD Sentinel server is intended to be on at all times, providing shared data and backup services. A best practice is to avoid turning the unit off. However, if it does become necessary (for example, moving the server to a different location), then follow the procedures below.

It is very important that the WD Sentinel server be shut down or restarted in a clean and graceful manner. There are two ways to do this:

- Through the **Server Settings** section in the Dashboard
- Through the power switch on the front panel of the server.

WARNING! To avoid a potentially unclean shutdown that could corrupt the RAID configuration, shut down the server through the Dashboard rather than the front panel.

To shut down or restart using the Dashboard (Preferred method):

1. Click **Server Settings** in the icon bar.
2. To shut down, right-click the red button in the lower left corner of the page and select **Shut down**.

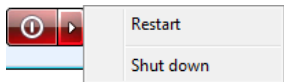

3. To restart, right-click the arrow and select **Restart**.
4. When the confirmation message appears, click **Yes**.

To perform a clean shutdown using the front panel:

1. Press the power button for approximately ½ sec. (You may have to press it twice quickly.) The LCD displays “SHUTTING DOWN.”

Note: In the event that the two methods above fail and you must force the unit off, hold down the power button for more than 3 seconds. The server powers off. When you turn it back on, the server executes a verification background task of the entire RAID system. This process may take a long time and degrade the performance. The unit is operational under this condition.

5

Managing Storage on the WD Sentinel Server

[WD Sentinel Server RAID Storage](#)
[Using USB Storage](#)
[Replacing a Failed Drive](#)
[Adding Capacity by Adding a Drive](#)

WD Sentinel Server RAID Storage

RAID is the acronym for Redundant Array of Independent Disks. The WD Sentinel server provides automatic RAID service to assure the integrity of the storage system. For redundancy, a minimum of two drives must be active. The operating system and all data are protected by the RAID structure. The server automates the management of the RAID.

With two drives installed into the system, RAID 1 (mirror) is employed. With three or four drives installed, RAID 5 offers fast performance by striping data across all drives. These RAID levels provide the system with both redundancy and optimum capacity.

	2 TB Drives	3 TB Drives
RAID Level 1 (2 Drives)	2 TB Capacity	3 TB Capacity
RAID Level 5 (3 Drives)	4 TB Capacity	6 TB Capacity
RAID Level 5 (4 Drives)	6 TB Capacity	9 TB Capacity

If a drive in the array fails, the data and operating system are still intact, and the WD Sentinel server continues to provide service.

Important: If you have one bad drive, the server operates normally. However, if a second drive fails, the server will no longer operate. You will need to recover the server and/or replace the failed drive(s). A best practice is to have a replacement drive readily available.

The WD Sentinel server lets you know when a drive fails in the following ways:

- The message "STORAGE DEGRADED" appears on the WD Sentinel server LCD.
- The LED above the bad drive is solid red.
- The Power LED on the WD Sentinel server flashes red, indicating a serious fault.
- An email Alert is posted if you have set it up to do so. (See "Monitoring System Health and Alerts" on page 21.)

To recover from a failed drive, simply replace the drive (the one with the red LED over the bay door) with an approved drive for the WD Sentinel server (see "Find compatible hard drives" on page 23). The WD Sentinel server validates the replaced drive and automatically integrates it into the RAID array. This operation takes many hours to accomplish. Progress of this operation appears on the display as well as on the Dashboard. It is not necessary to power off or disengage the WD Sentinel server to perform this operation. While the server is verifying the RAID array, your data continues to be available although the performance may be impacted.

The WD Sentinel server RAID system has no downgrade options. Once available capacity has been increased, the Administrator cannot decide to subsequently reduce capacity by removing a drive. The removal of a drive degrades the RAID and makes it vulnerable to single drive failure.

Using USB Storage

On the back of the WD Sentinel server are two USB 3.0 ports that can connect to external USB 2.0 or USB 3.0 storage devices or to a UPS device for power outage conditions. For example, WD Passport or WD Essentials may be used to connect to the WD Sentinel server. You can share this data on your USB drive with other users connected to the server by using the Dashboard, which treats the USB drive as a share. You can set user privileges just as you do with shared folders on the WD Sentinel server's drives. The server manages UPS capability through a USB port for communication and to ensure an orderly shut down.

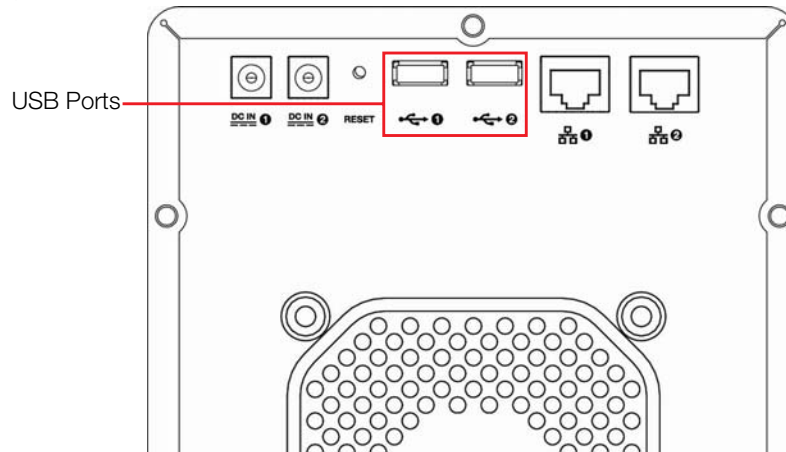

To share data on a USB drive:

1. Connect a USB drive to either of the two USB ports.
2. On the Dashboard, click the **Servers Folders and Hard Drives** icon.
3. Click the **Server Folders** tab.
4. In the Task bar, click **Add a folder**.

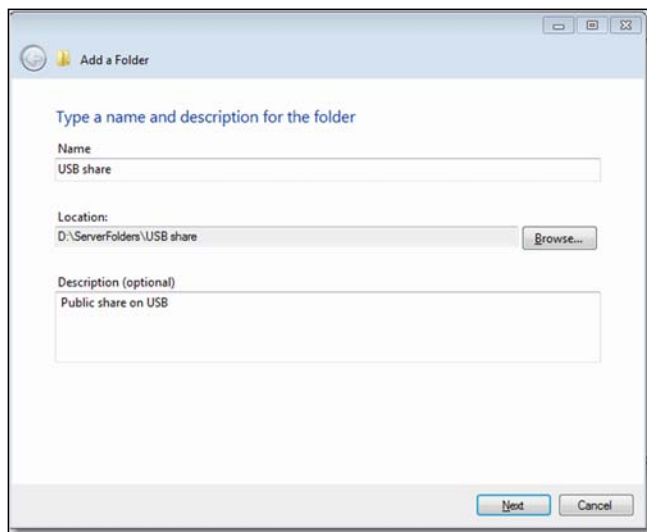

5. Enter a name for the folder.

- Click **Browse** and select a folder on the USB drive. Note that a shared folder cannot be created at the root of the USB drive.

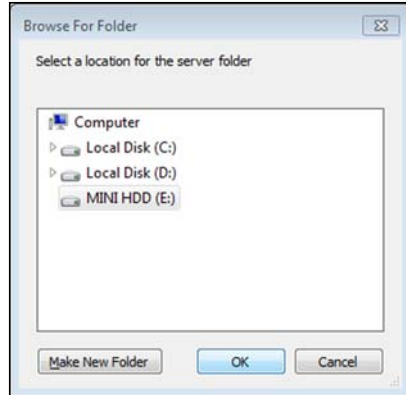

- Click **OK** and follow the instructions on the screen.

To stop sharing data on a USB drive:

- On the Dashboard, click the **Servers Folders and Hard Drives** icon.
- Click the **Server Folders** tab, then select the folder you want to stop sharing.
- On the Task bar, click **Stop sharing the folder**.

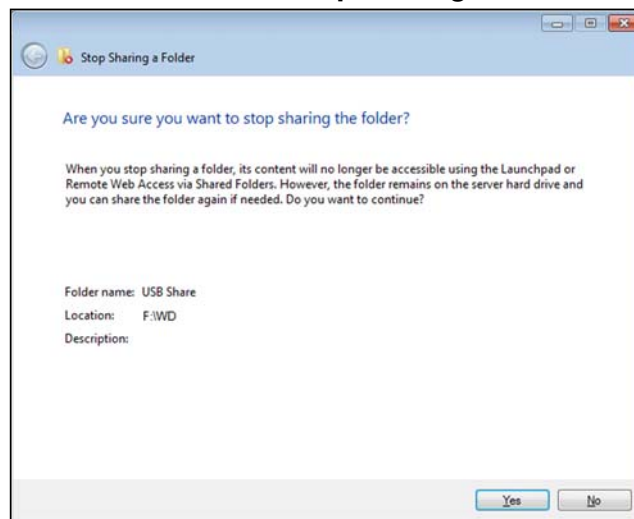

- Click **Yes**, then click **Close**.

Replacing a Failed Drive

It is simple to replace a failed drive in your WD Sentinel server. First, make sure to go to the WD Store to purchase a compatible replacement drive. For a complete list of approved drive models, search for Answer ID 9443 in the WD Knowledge Base at <http://support.wdc.com>.

The drives in the WD Sentinel server are “hot swappable.” This means that the WD Sentinel server can remain powered on while you replace the drive. Once you replace the drive, the WD Sentinel server automatically reconfigures the RAID. (See “Find compatible hard drives” on page 23.)

Use the following steps to replace a failed drive in your WD Sentinel server.

- Verify that the LED for the bad drive is solid red.

2. Open the door on the front of the server.

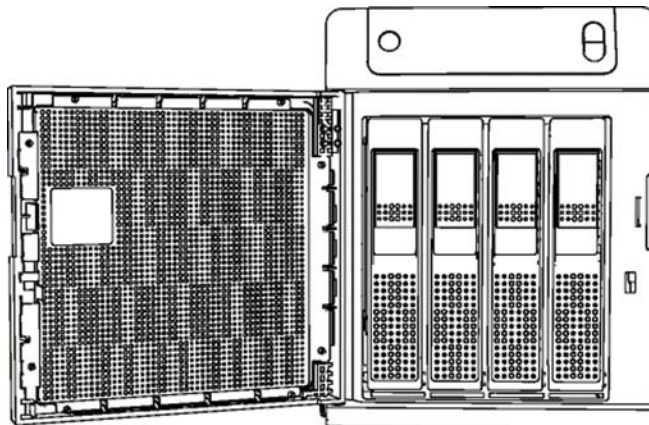

3. Unlatch the handle on the front of the drive.
4. When it snaps open, pull out the drive.

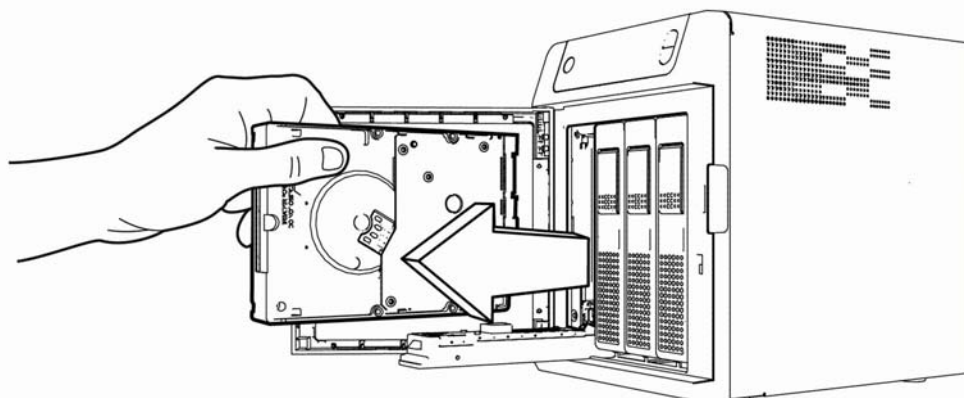

5. Slide the replacement drive into the drive bay, making sure it is seated properly, and that it is facing the right way.
6. Using some force, snap the handle shut.

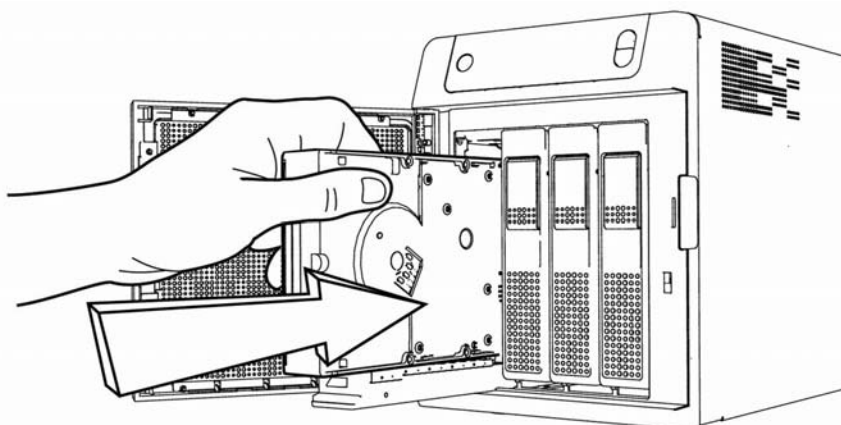

7. Close the door on the front of the server, making sure it snaps shut. The LED remains blank until the rebuild is complete. The rebuild percentage displays on the LCD.

Adding Capacity by Adding a Drive

To increase capacity, simply insert an additional drive into the system. The system does not have to be turned off or disengaged from its work to do this. The WD Sentinel server automatically recognizes the drive, checks to see if the drive is approved for use in the WD Sentinel server, and reconfigures the RAID to accept the new drive. At the completion of this reconfiguration, the additional capacity is automatically available to the system. No further operation is required.

Note: The additional drive must have a minimum available capacity of the smallest drive in the array. For example, a 3 TB drive may be added to an array made up of 2 TB drives, but a 2 TB drive may not be added to an array composed of 3 TB drives.

Use the following steps to add a drive to your WD Sentinel server.

1. Open the door on the front of the server.
2. Unlock the handle on the empty drive bay and insert the drive into the bay, making sure it is facing the right way and is seated properly.
3. Using some force, snap the handle shut.

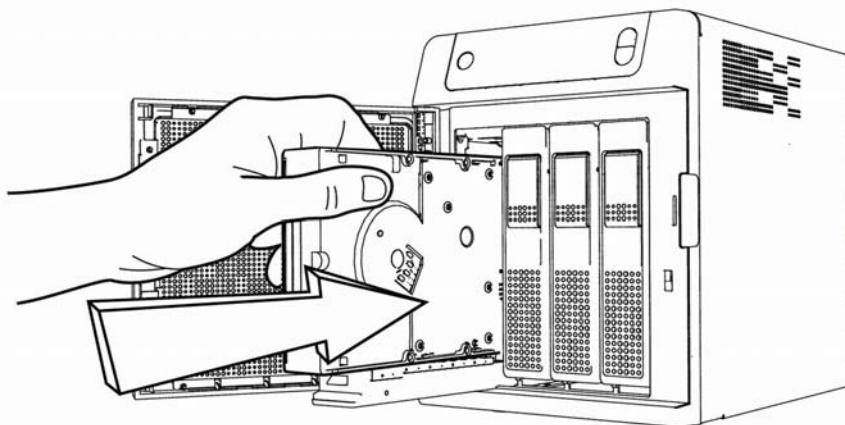

4. Close the door.

6

Using the WD Sentinel Server's Features

[Using the Launchpad \(Internal Users\)](#)
[Accessing Shared Folders Over Your Network](#)
[Accessing Computers and Shared Folders Remotely](#)
[Backing up \(Windows PC\)](#)
[Recovering/Restoring \(Windows PC\)](#)
[Recovering/Restoring \(Windows PC\)](#)
[Recovering the WD Sentinel Server](#)

This chapter describes the routine tasks that both the Administrator and permitted users perform on the WD Sentinel server.



Using the Launchpad (Internal Users)

After you, the Administrator, use the Dashboard to set up users with a user name, password, and permissions, they can access the Launchpad Sign-in page using one of the following methods:

Best Practice: Ideally, you set up a user name and password for yourself and given it all access privileges so you too can use the Launchpad shortcuts.

Accessing the Launchpad

To access the Launchpad (Windows):

- Do one of the following:
 - Click **Start () > (All) Program(s) > Windows Storage Server 2008 R2 > Windows Storage Server 2008 R2 Launchpad.**
 - Double-click the Launchpad icon .
 - Right-click the Launchpad icon  in your system tray and select **Open Launchpad.**

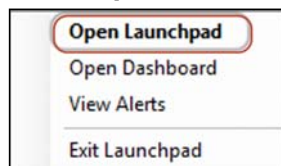

2. Enter your user name and password.



3. Click the **right arrow** to display the Launchpad, which lists four tasks that authorized users can perform: **Backup**, **Remote Web Access**, **Shared Folders** and **Dashboard**.

Note: The **Dashboard** option is only useful to a user with Administrative privileges and knowledge of the Administrator password.



To access the Launchpad (Mac):

1. Do one of the following:
 - Double-click the Launchpad icon on your Mac Toolbar.

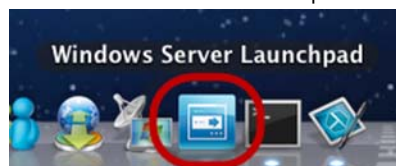

- Select **Finder>Applications>Windows Server Launchpad**

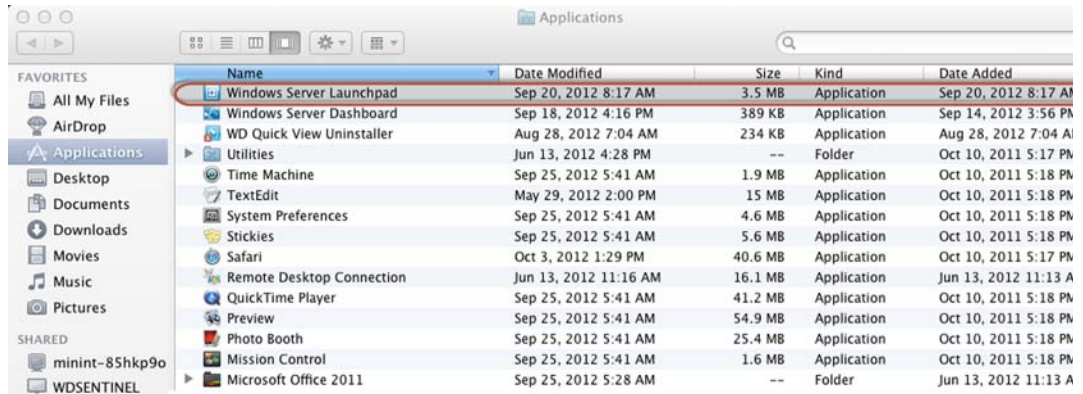

Once you've accessed the LaunchPad Sign In screen, use the following steps to sign in and use the Launchpad.

1. Enter your user name and password.



2. Click the arrow to display the Launchpad. It lists four tasks: **Backup**, **Remote Web Access**, **Shared Folders**, and **Add-ins**.



Selecting Launchpad Options (Windows PC or Mac Computer)

To select Launchpad options:

IF you want to . . .	THEN . . .	AND ...
Back up your Windows PC to the WD Sentinel server manually	Click Backup	Continue to “Backing up (Windows PC)” on page 42.
Back up your Mac to the WD Sentinel Server using Time Machine.	Click Backup	Continue to “Backing up with Time Machine (Mac)” on page 45.
Use Remote Web Access: <ul style="list-style-type: none"> • Enable remote web access for users with Remote Access Privileges. • Access the server from a remote location (all users) • Change a user password (by the user) 	Click Remote Web Access	Continue to “Remote Web Access” on page 26 and “Accessing Computers and Shared Folders Remotely” on page 41.
Access shared folders on the server	Click Shared Folders	Continue to “Accessing Shared Folders Over Your Network” on page 40.
Manage the server (Windows PCs and Administrators only)	Click Dashboard	Enter the Administrator password and continue to “Managing the WD Sentinel Server (Dashboard)” on page 16.
Manage the server (Mac and Administrators only)	Click Add In , then click Dashboard .	Enter User Name (Administrator) and Password (The password you created at setup), then continue to “Managing the WD Sentinel Server (Dashboard)” on page 16.

Managing the Launchpad

To disable the Launchpad after signing in (Windows):

1. Sign in to the Launchpad.
2. Click the menu **arrow** at the top right and select **Settings** from the drop-down menu.



3. Clear the **Automatically run the Launchpad when I log on to Windows** check box, and click **OK**.

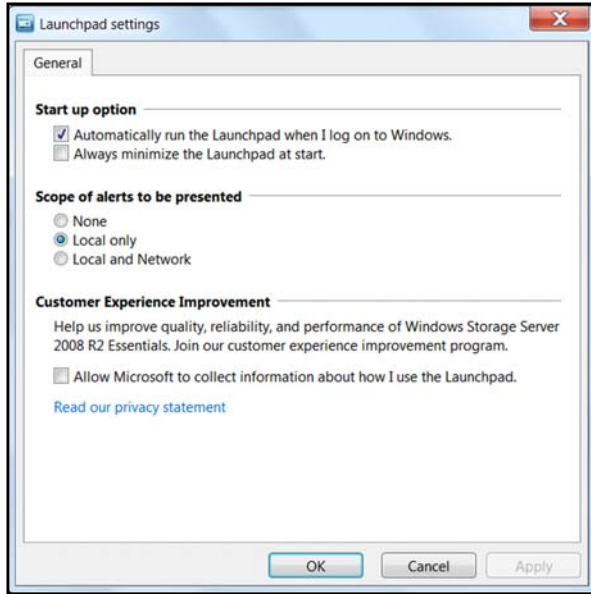

Note: You can also change the type of alerts that display on the Launchpad and select whether to allow Microsoft to send you information about it in this window.

To disable the Launchpad after signing in (Mac):

1. Sign in to the Launchpad.
2. Click the menu **arrow** at the top right and select **Settings** from the drop-down menu.



3. Clear the **Automatically run Windows Server Launchpad when I log in** check box, and click the Close button .

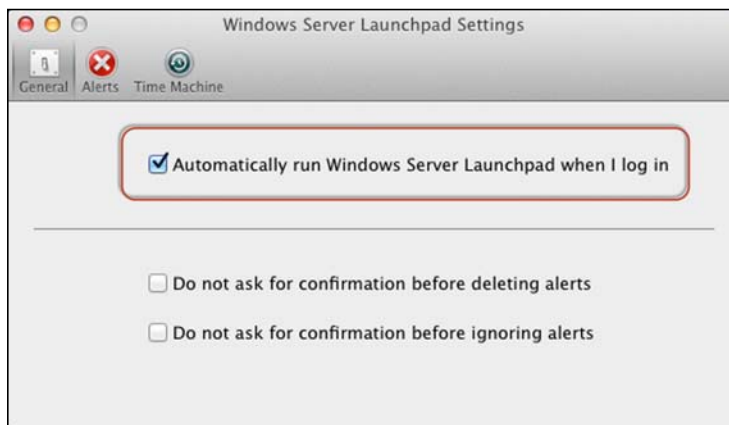

You can also change the type of alerts that display on the Launchpad selecting whether to allow Microsoft to send you information about it in this window, and setup your Time Machine backups.

To uninstall the Launchpad (Connector Software) on a Windows PC:

Note: When you uninstall Launchpad, you also uninstall Dashboard. They can not be uninstalled separately.

1. Click **Start**, click **Control Panel**, and in the Programs section, click **Uninstall a Program**.
2. From the list, select **Windows Storage Server 2008 R2 Connector**.
3. Click **Uninstall**.
 - If the User Account Control window displays, click **Allow**.
 - If the Windows Storage Server 2008 R2 Essentials Connector page displays suggesting that you close the Launchpad, click **OK**.

Note: You must reboot the computer before installing another Connector.

To uninstall the Launchpad (Connector Software) on a Mac:

You must uninstall Launchpad from three Macintosh HD folders: Users, Applications, and Library.

1. Quit the Launchpad.
2. In the Finder pane, click **Applications**. Drag and drop **Windows Server Launchpad** into the **Trash** icon. The Launchpad icon no longer appears in the dock.
3. Click **Finder>Devices>Macintosh HD**.

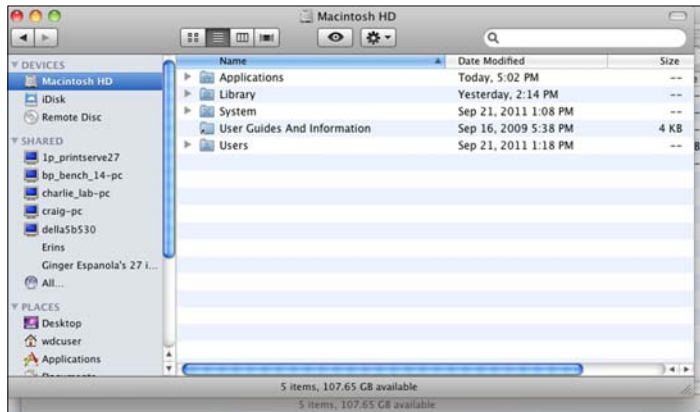

4. Click **Library>Application Support>Microsoft**. Drag and drop **Launchpad** into the **Trash** icon.
5. Click **Library>Preferences**. Drag and drop "**com.microsoft.launchpad.plist**" into the **Trash** icon.
6. Right-click the Trash icon and select

Accessing Shared Folders Over Your Network

Launchpad (Windows)

1. On the Launchpad, click **Shared Folders**. A set of folders similar to the one below displays:

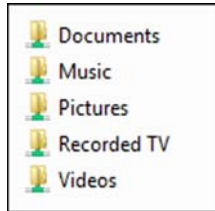

2. Double-click a folder to open it, then click the file you want to access. Your access (as a general user) depends on the permissions assigned to you by the Administrator.

Launchpad (Mac)

1. On the Launchpad, click **Shared Folders**.
2. Select the shared folder you'd like to mount on your mac, then click **OK**.

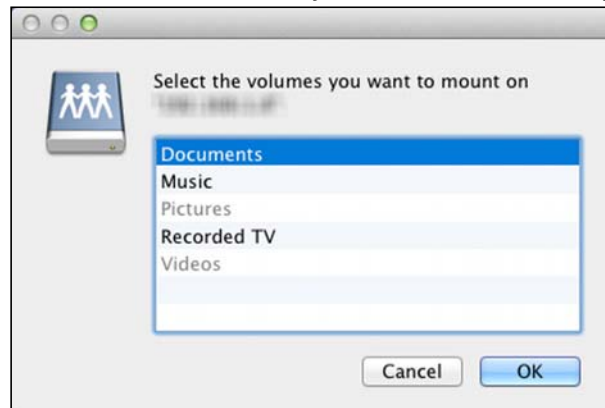

- If all shared folders are mounted on your Mac, click **Cancel**, then open Finder. Click the IP Address of your WD Sentinel under Shared to display your Shared Folders.
3. The selected shared folder displays on your desktop.

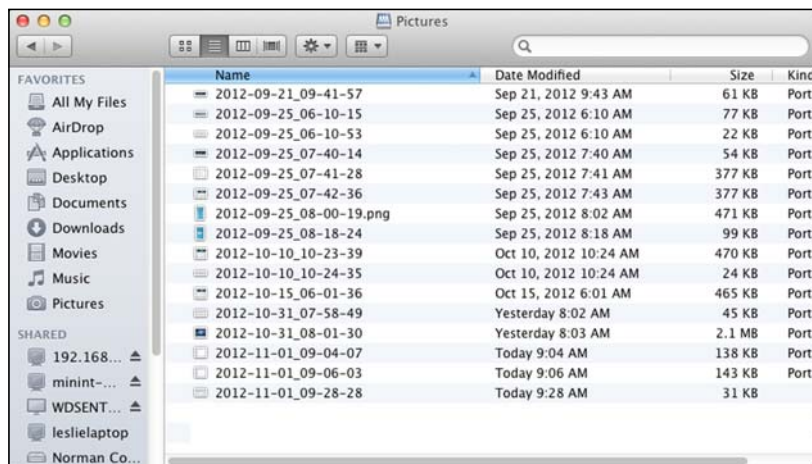

Accessing Computers and Shared Folders Remotely

This section assumes that the Administrator has completed the setup and configuration for Remote Web Access through the Dashboard.

You can access files stored on the WD Sentinel DX4000 anywhere, as long as you have access to the Internet.

Note: You must use Internet Explorer 8 or 9 to access a PC using the Remote Web Access feature. See "Specific Problems and Corrective Actions" on page 62.

Logging In

1. On the Launchpad, click **Remote Web Access** or on a web browser, enter the domain address for your WD Sentinel server. This is the domain address the Administrator configured while setting up Remote Web Access on your WD Sentinel server. The following web page displays in your browser.

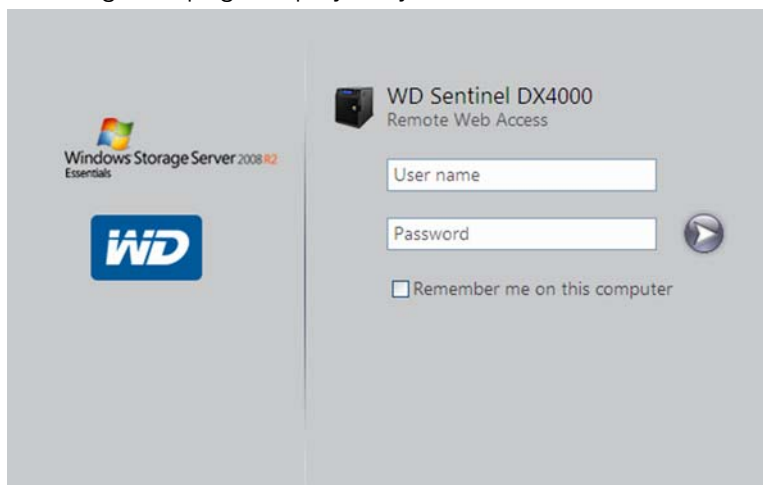

2. Enter your WD Sentinel server user name and password, then click the **arrow** to display the Remote Web Access: Home for User window:

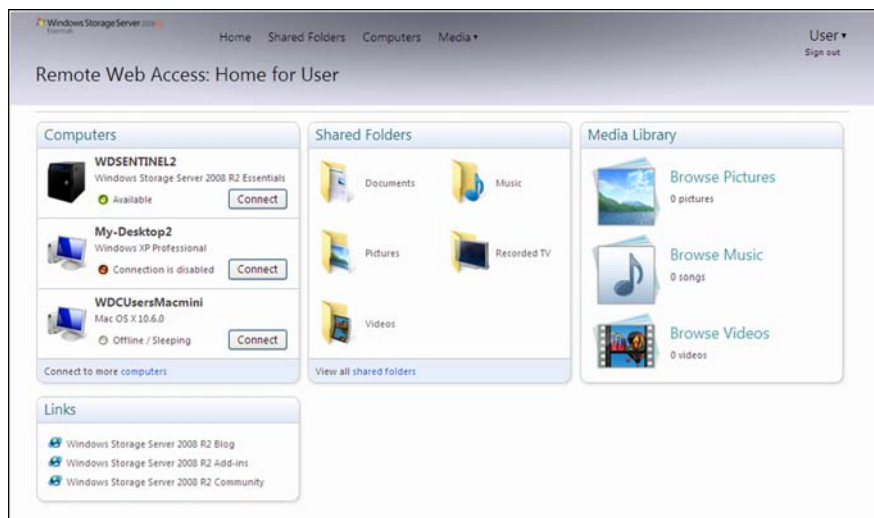

Remote Web Access Home Page

The Remote window includes the following sections:

Note: You can also use the navigation links at the top of the window to view these sections.

Computers

Note: Connecting to computers or the WD Sentinel server using Remote Web Access requires the Internet Explorer browser.

- Click **Connect** to connect to your WD Sentinel server or to a computer on your network.
 - If the Internet Explorer you are using does not have Active X Client, click **OK** to install it, then complete the wizard.

Shared Folders

Access shared folders on the WD Sentinel server. The folders may include Documents, Pictures, Music, Video, Recorded TV, and any additional shared folders the Administrator may create using the Dashboard. A user with "Read & Write" access to a particular shared folder is able to modify the contents of the existing files, upload new files, or delete files from the folder.

Note: Only the folders for which the user has permissions are displayed under Shared Folders on Remote Web Access.

Media Library

Browse through your pictures, music, videos, and recorded videos. The WD Sentinel server automatically discovers the media files and adds them to your media library. The built-in media capabilities allow you to view your pictures in a slideshow, stream digital music, or stream videos over the web.

Backing up (Windows PC)

The WD Sentinel server backup is based upon block level de-duplication, a process that backs up data without unnecessarily backing up the same data more than once. This powerful process uses less network traffic for execution, provides a full back-up at each backup time (although it behaves as if it is incremental), and by executing de-duplication across all client computers, the storage capacity requirements are significantly reduced. Backup becomes an automatic process for a computer once you install Connector software on it. With Connector software installed, all volumes and all NTFS data on that computer are backed up.

Note: For information on backing up your Mac using Time Machine, See "Backing up with Time Machine (Mac)" on page 45.

Scheduling Automatic Backups (Dashboard only)

To set a schedule for future backups:

1. Access the Dashboard.
2. Click the **Computers and Backups** icon on the navigation bar to display a list of computers and servers on your network:

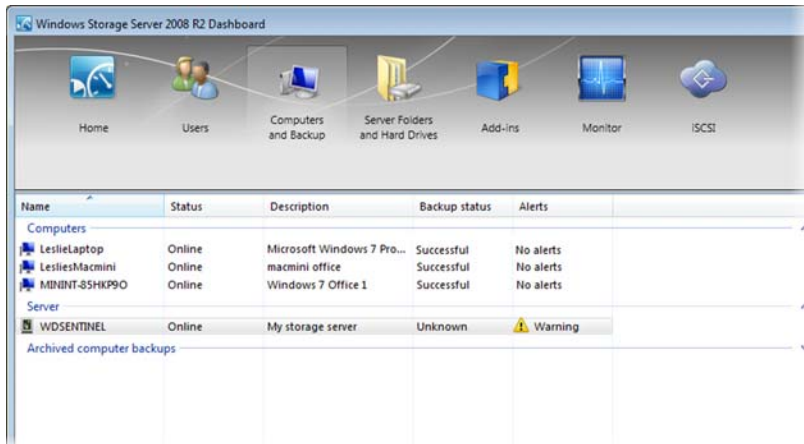

3. Click **Additional client computer backup tasks** in the task panel.

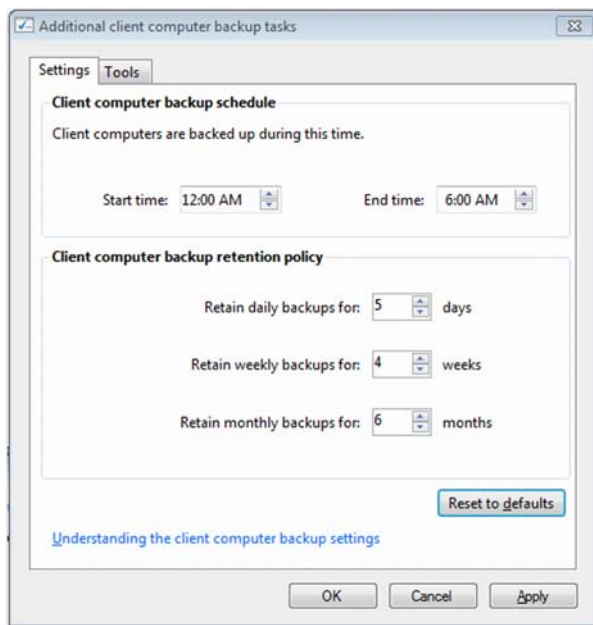

4. Enter the **Start time** and **End time** for daily backups and click **OK**.



Initiating Backups

By default, backups are performed at night for up to 25 client computers in a sequential order. If the client computer is asleep or hibernating at that time, the backup software can be enabled to wake up the client computer, back it up, and put it back to sleep.

You may start a backup either through the **Launchpad** on the computer being backed up or through the Dashboard.

Backup Using the Launchpad

Note: For information on accessing the Launchpad, see “Using the Launchpad (Internal Users)” on page 34).

1. On the Launchpad, click **Backup**. The Backup Properties page displays:

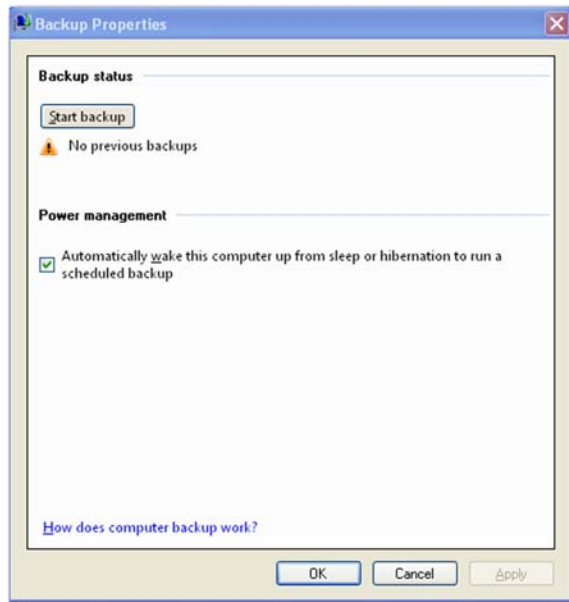

2. Click **Start backup**.
3. Enter a name for the backup and click **OK**:

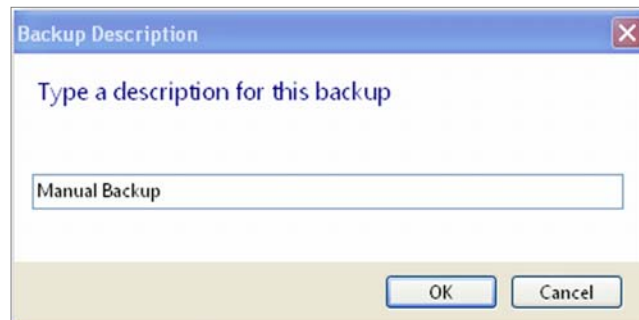

The Backup Properties page re-displays and tracks the progress of the backup.

Note: If you want the computer to automatically wake up for scheduled backups, select the check box.

4. Click **OK** to apply the change, close the page, and return to the Launchpad while the backup continues.

The message that the backup was successful displays on the page and on the Dashboard. For more information about the backup process, see [Microsoft Online Help](#).

Backup Using the Dashboard

1. Click the **Computers and Backups** icon on the navigation bar to display a list of computers and servers on your network:



2. Select the computer you want to back up.
3. Click **Start a Backup for the Computer** in the Task pane. For further instructions, see [Microsoft Online Help](#).

Backing up with Time Machine (Mac)

For Mac users, Time Machine allows you to backup data to your WD Sentinel server. Time Machine automatically backs up your entire Mac, including system files, applications, accounts, preferences, email messages, music, photos, movies, and documents.

Note: Time Machine keeps hourly backups for the past 24 hours, daily backups for the past month, and weekly backups until your backup drive is full.

For additional information on Time Machine, consult your Apple documentation.

Note: For information on backing up your PC, See "Backing up (Windows PC)" on page 42.

Scheduling Automatic Backups (Time Machine)

To set up and schedule Time Machine to back up files to your WD Sentinel server:

1. Use one of the following methods to open Time Machine.
 - Click the Time Machine icon in the Dock:

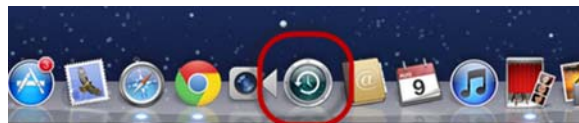

- Click the **Apple menu**  > **System Preferences** and select **Time Machine**.
- Click **Go > Applications** and select **Time Machine**.

2. If this is your first time creating a backup, the following screen displays:



3. Click **Set Up Time Machine** to display the Time Machine Preferences screen:



4. Click **Select Disk** and select the WD Sentinel server for your backups:

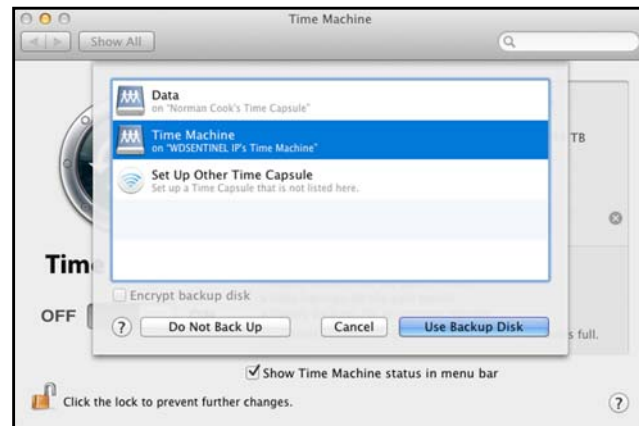

5. Click **Use Backup Disk**. A screen prompts for your user name and password.
6. Select **Registered User**.

7. Enter your assigned WD Sentinel User Name and Password in the Name and Password fields:



8. Click **Connect**. The Preferences screen returns.
9. To start automatic backups, move the slider to **ON**.

Time Machine begins backing up your files. The first backup may take some time, but subsequent backups are faster because Time Machine only backs up new or changed items.

Time Machine backs up your computer every hour and keeps the following backup sets:

- Every hour for 24 hours
- Every day for the past month
- Weekly until the WD Sentinel drive is full.

Note: If a backup is interrupted, for example, if the computer goes into sleep mode, it will resume automatically once the computer is available.

To see information such as available capacity and the date and time of the oldest, latest, and next backup, select **Open Time Machine Preferences** on the Time Machine drop-down menu:



Recovering/Restoring (Windows PC)

The WD Sentinel server provides two options for recovering lost or corrupted data:

- **Restore a Computer**—Restores all the data and settings of a Windows PC computer or a storage device connected to the WD Sentinel server.
- **Recover File/Folders** —Recovers individual files or folders.

Note: For information on recovering/restoring data on your Mac using Time Machine, See “Recovering/Restoring (Mac)” on page 49.

Restoring Windows PC Computers (Bare Metal Restore)

This feature restores a Windows PC connected to your WD Sentinel server. Should your computer experience an unfavorable event such as a hard drive crash, the Recovery feature reinstalls the operating system, software applications, and all the data. This type of recovery is known as a bare-metal restore; it recovers everything that was on the computer when it was backed up.

Best Practice: You may need some network drivers. Save them to a USB flash drive.

To restore a Windows PC that has been backed up:

1. Click **Computers and Backups**  on the navigation bar.
2. Select the computer that was backed up.
3. Insert a USB flash device into one of the WD Sentinel server's USB ports.
4. In the panel on the right, click **Additional Client Computer Backup Tasks** and then **Tools:**

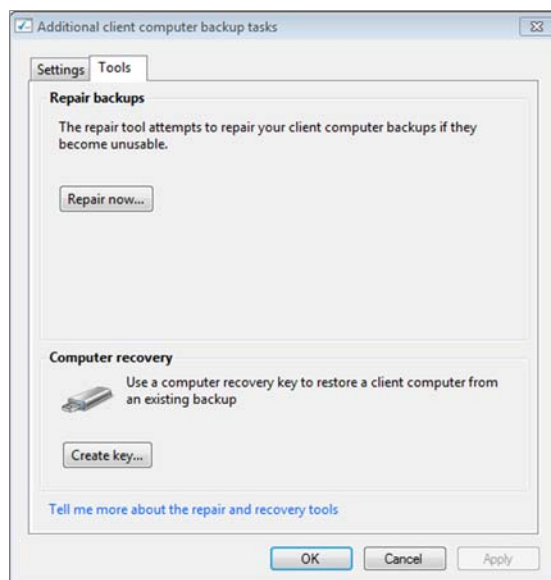

5. Click **Create Key** to generate a bootable USB flash key (configuration file) on the connected USB flash drive. You will use the key to boot the PC and download the backed-up system. Follow the wizard to complete the process.
6. Remove the USB flash drive from the WD Sentinel server and connect it to the computer you want to restore.

7. Boot the Windows PC from the USB flash drive:
 - a. Start the computer.
 - b. Depending on your computer, press **F12** or another key that displays boot options.
 - c. From the Boot menu, select **USB Device**.
 - d. On the Windows Boot Manager, select a Windows operating system for a full-system restore. The Full System Restore wizard Welcome screen displays.
 - If a message indicates that you do not have the correct network card driver, insert the USB flash drive with the driver into another USB port on the Windows PC, and follow the steps in the wizard to restore the computer.
 - If you do have the correct driver, click **Continue** and complete the steps in the wizard to restore the computer.

Note: Refer to [Microsoft Online Help](#) for additional information.

To recover individual files and folders:

1. Click the **Computers and Backups** icon and select the computer from which you would like to recover the backup files.

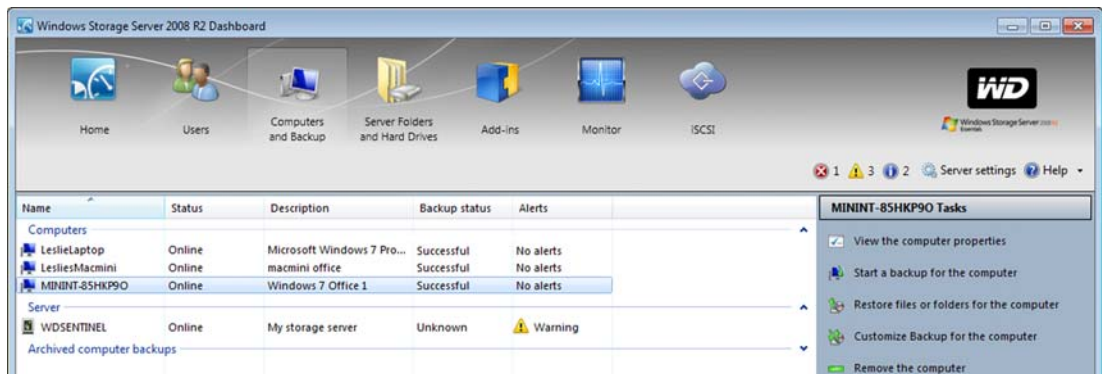

2. In the Task panel, click **Restore Files or Folders for the Computer**. The server displays a list of your backups.
3. Select the backup that has the files and folders you want to restore and click **Next**.
4. Follow the wizard to select the files and folders and recover them to your computer. See [Microsoft Online Help](#) for additional information.

Recovering/Restoring (Mac)

Time Machine allows you to restore files, versions of files, or your entire system. For additional information on recovering or restoring your system files, consult your Apple documentation.

Note: For information on recovering/restoring data on your PC, See “Recovering/Restoring (Windows PC)” on page 48.

1. On the Launchpad, click **Backup**. Your Time Machine backups display.

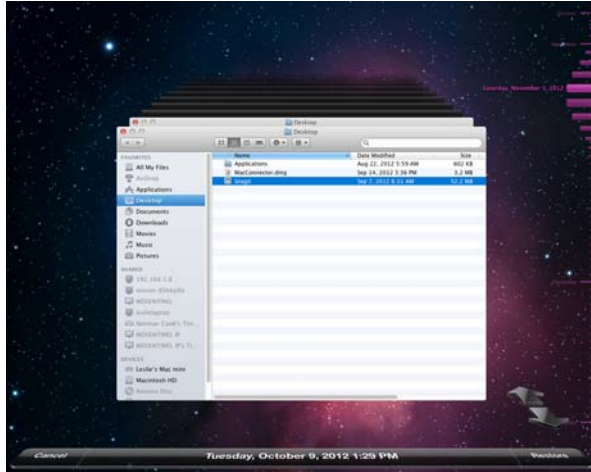

2. Select the date you'd like to restore to from the time line on the right of the screen.
3. Click **Restore** in the bottom right-hand side of your screen.

Recovering the WD Sentinel Server

This feature recovers your WD Sentinel server, a process that may be necessary in case the server has a virus that cannot be deleted, bad or corrupted server configuration settings prevent you from starting the server, or the system drive(s) failed.

Best Practice: You may lose some of your data, depending on the type of recovery you perform.

Requirements

- Virtual DVD software

Note: Free virtual DVD software is available on the internet. See “Create a Virtual DVD” on page 50.
- USB flash drive, 16 GB or larger
- Windows PC
- DVD burner or DVD emulation software

Note: Free DVD emulation software is available on the Internet. For more information on emulation software, see Knowledge Base Answer ID 8561.

Create a Virtual DVD

WARNING! **WD does not assist in the installation of third party programs such as a Virtual DVD. The information provided below is to assist customers with the creation of a recovery disk for a WD Sentinel DX4000. Western Digital is not responsible for any damage to your computer or data resulting from using third party software.**

1. Download the [Server Recovery ISO](#) file and save it to a preferred location on your computer.

2. Download and install a virtual DVD software program. Available virtual DVD programs include:
 - PowerISO (<http://www.poweriso.com/>)
 - Virtual CloneDrive (<http://www.slysoft.com>)
3. Following your third-party software instructions, mount the Server Recovery ISO to a virtual DVD.

Run the Virtual DVD

1. Mount the Recovery DVD into your computer following the instructions for your virtual DVD software.
 - If you are running Windows Vista/Windows 7, click **Run Setup.exe** on the window that displays:



- If you are running on a Windows XP computer, by clicking **Setup.exe** under **My Computer**.
2. After the application runs, a Server Recovery Utility window appears with three options:
 - Unlock my drives
 - Recreate my storage
 - Perform a recovery

These options are explained below.

Unlock my drives

Unlock my drives unlocks the WD Sentinel server's drives if they are locked. (See "Lock/Unlock" on page 23.) Before starting any recovery process, unlock the drives with an unlock key.

To create an unlock key:

1. On the Server Recovery Utilities window, click **Unlock my drives**.

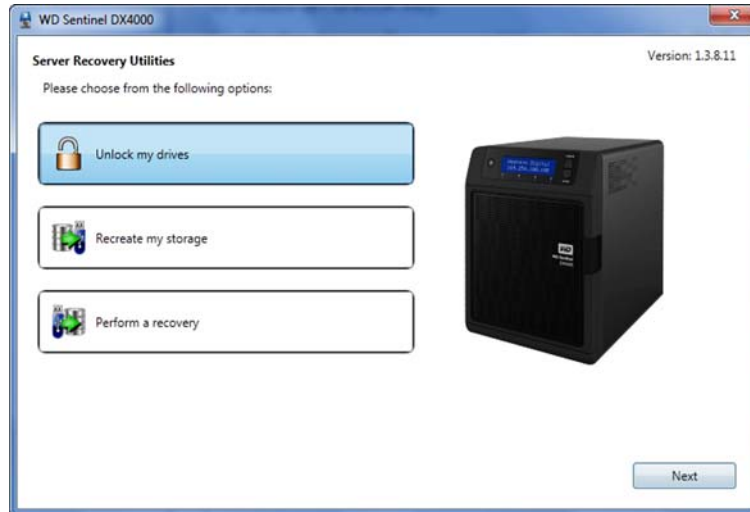

2. Click **Next** and enter the password previously set to lock the drives. Keep in mind that this password is not the WD Sentinel server's Administrator password. It is the locked drives password (see "Lock/Unlock" on page 23). If the Administrator password was used to lock the drives, enter it here.



3. Insert the USB flash drive into the Windows PC USB port. The USB flash drive should appear in the **Select USB flash drive** drop-down list.

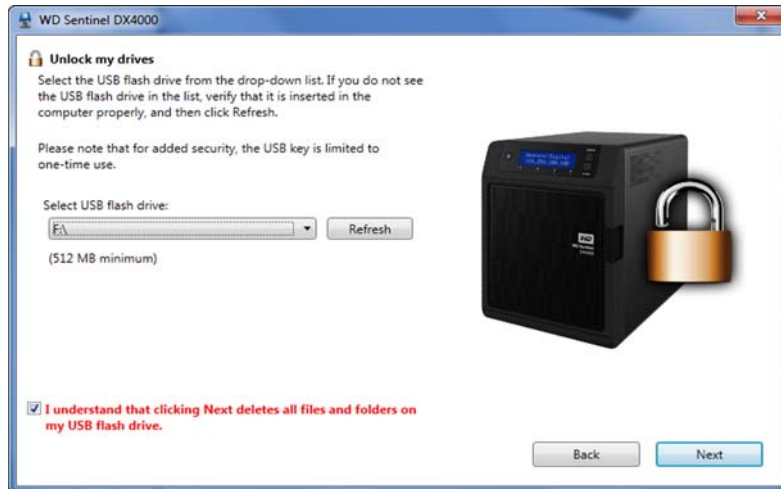

4. If the USB flash drive is not on the list, click **Refresh** and search for it.
5. After locating the USB flash drive, click the **"I understand..."** check box to indicate that you know the process will delete all files and folders on your USB flash drive.
6. Click **Next** to display the "Congratulations and Next Steps" page.

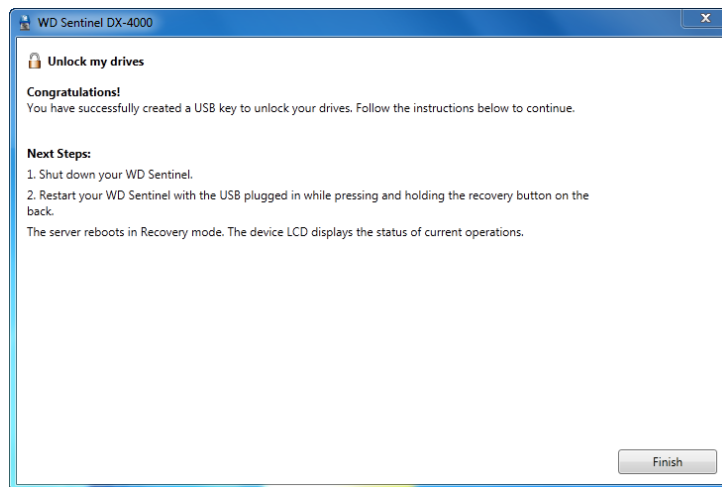

7. Follow the steps listed on this page:
 - a. Shut down the WD Sentinel server.
 - b. Insert the USB flash drive into one of the server's USB ports.
 - c. Restart your server while pressing and holding the **Recovery** button on the back of the server.
 - d. Continue to hold the **Recovery** button until the LCD displays "INITIALIZING OK. LOADING RECOVERY." Release the **Recovery** button.
 - e. Allow the recovery process to complete. When it is done, the LCD displays "UNLOCK DRIVES SUCCESS."

Recreating the storage

The “Recreate my storage” option recreates the storage partition and RAID for your WD Sentinel server.

WARNING! Only use this option if you are replacing all drives or if the partition or RAID is corrupted. This option may delete user data.

1. On the Server Recovery Utilities page, click **Recreate my storage**.

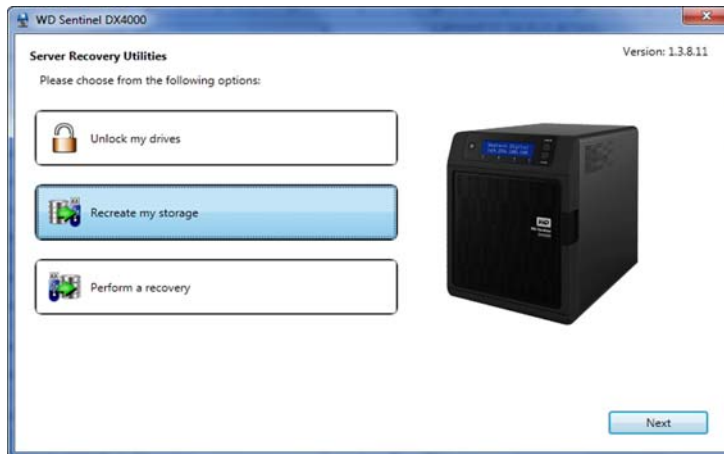

2. Click **Next**. The Recreate Storage page displays:

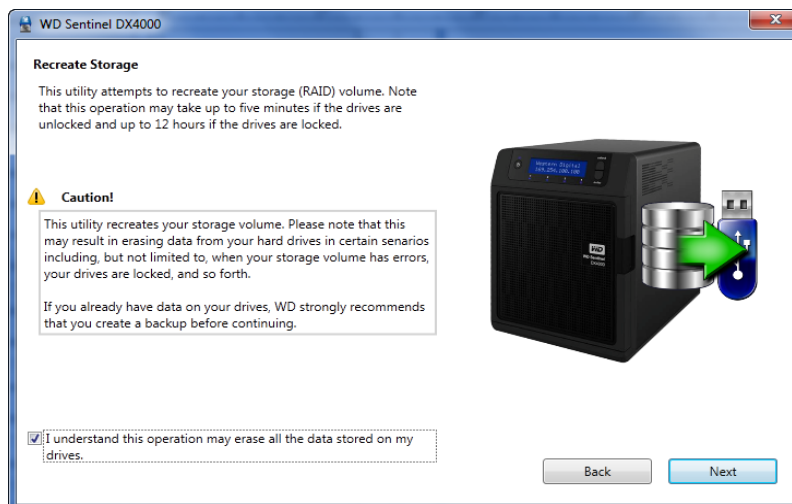

3. Read the caution and click the check box to indicate you know the process may erase the data on the WD Sentinel server's drives while it recreates the server's configuration.

4. Insert the USB flash drive into the USB port of the Windows PC, and click **Next** to display the following page for using the USB key:

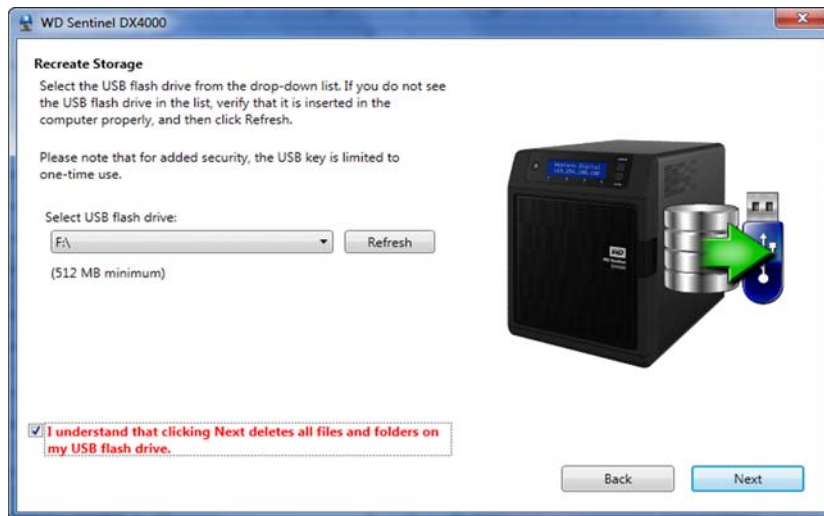

5. The USB flash drive should appear in the **Select USB flash drive** drop-down list. If the USB flash drive is not on the list, click **Refresh** and search for it.
6. After locating the USB flash drive, click the check box acknowledging that you know that when you click **Next**, all files and folders on the USB flash drive will be deleted.
7. Click **Next**. A progress bar displays while the USB flash drive is being prepared.

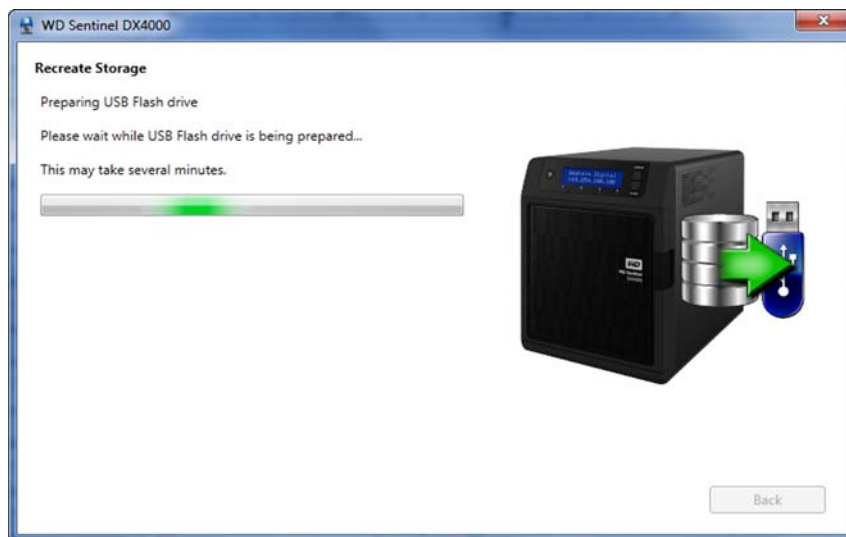

8. Upon completion of the process, the Recreate Storage page displays:

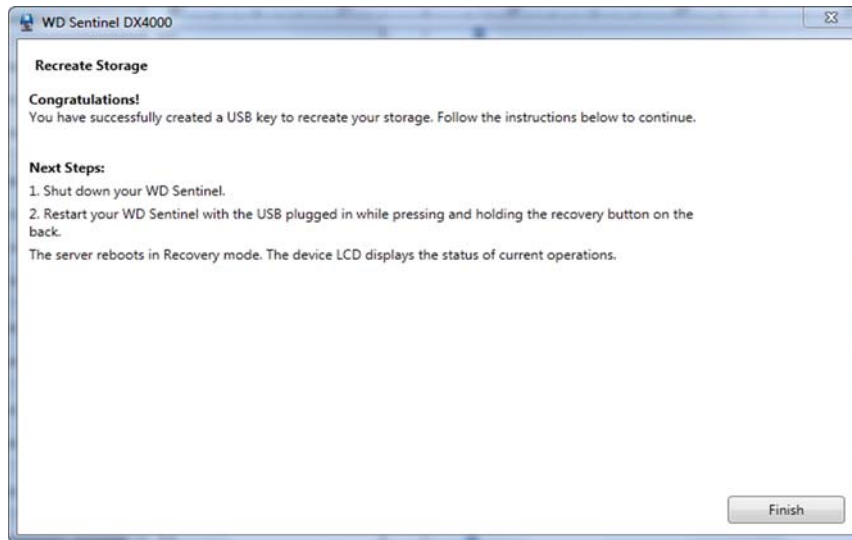

9. Follow the instructions under **Next Steps**:
- Shut down the WD Sentinel server.
 - Insert the USB flash drive into one of the server's USB ports.
 - Restart your server while pressing and holding the **Recovery** button on the back of the server.
 - Continue to hold the **Recovery** button until the LCD displays "INITIALIZING OK. LOADING RECOVERY." Release the **Recovery** button.
 - Allow the recovery process to complete. When it is done, the LCD displays "STORAGE OK."
10. When the process is done, the server's LCD displays "STORAGE OK." Click **Finish**.

Performing a Recovery

This option enables the Administrator to restore the server to factory defaults with or without deleting all contents stored on the WD Sentinel server.

1. On the Server Recovery Utilities window, click **Perform a recovery**:

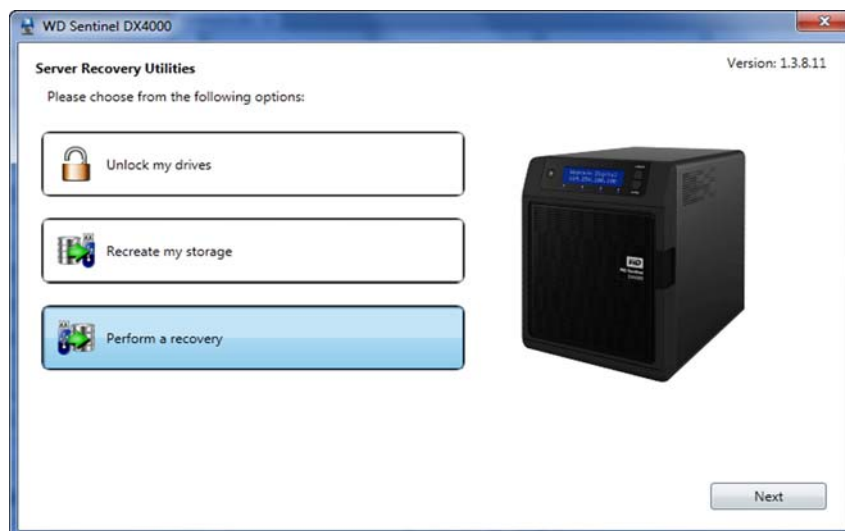

2. Click **Next**. The Getting Started page displays:

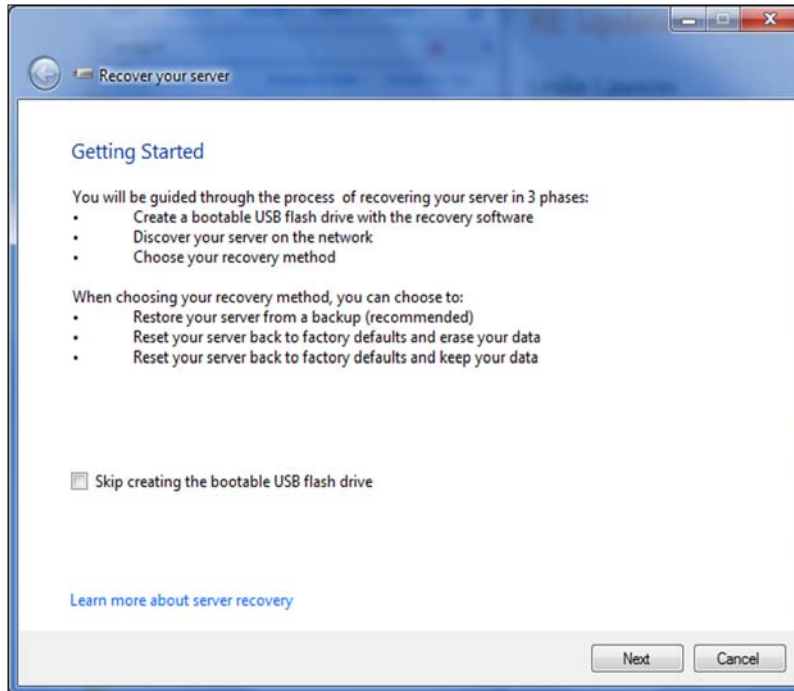

3. Read the information on the screen.

- If you have previously created a bootable recovery USB flash drive, click the **Skip creating the bootable USB flash drive** check box and continue to Step 9.

Click **Next**. The Create a bootable USB flash drive for server recovery screen displays:

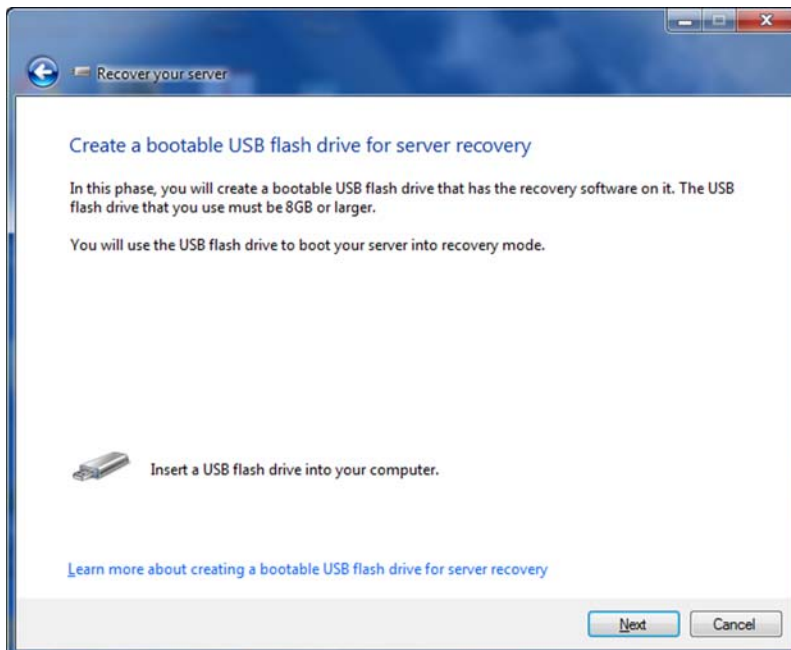

4. Insert the USB flash drive into the USB port of the Windows PC, and click **Next**. The Prepare the USB flash drive for server recovery screen displays.

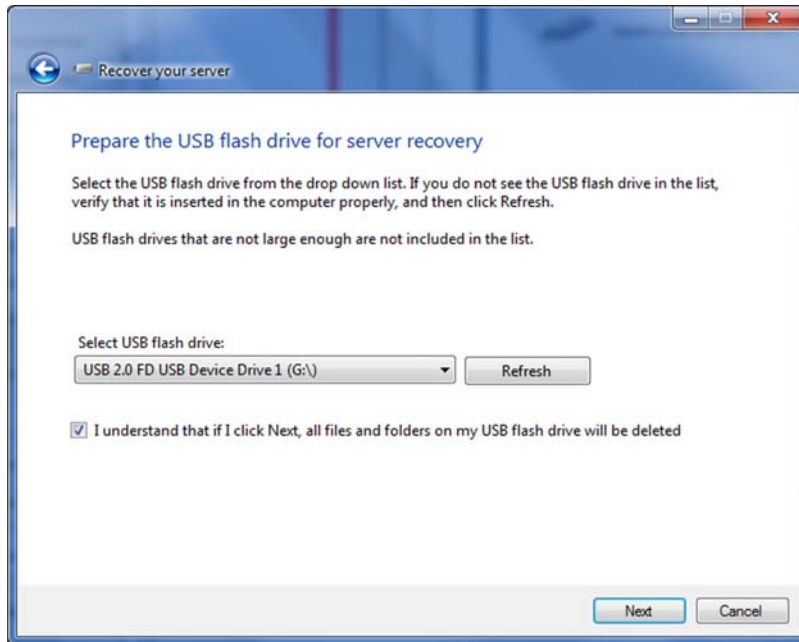

5. The USB flash drive should appear in the Select USB flash drive drop-down list. If it is not on the list, click **Refresh** and search for it.
6. After locating the USB drive, click the check box to acknowledge that you know clicking **Next** will delete all files and folders on the USB flash drive.
7. Click **Next**. The Preparing the USB flash drive for server recovery screen displays.
8. The recovery application on the DVD prepares the USB drive. This process can take up to 15 minutes to complete. After the USB drive preparation is done, the Start your server in recovery mode screen displays.



9. Follow the additional instructions that appear on the screen to guide you through the recovery process:

- a. Shut down the WD Sentinel server.
 - b. Insert the USB flash drive into one of the server's USB ports.
 - c. Restart your server while pressing and holding the **Recovery** button on the back of the server.
 - d. Continue to hold the **Recovery** button until the LCD displays "INITIALIZING OK. LOADING RECOVERY." Release the **Recovery** button.
 - e. Wait until the LCD displays "RECOVERY STARTED."
10. Return to the PC and follow the instructions by clicking **Next**. Make sure the PC is on the same network as the WD Sentinel server. The application searches for the WD Sentinel server and performs the final recovery. When the recovery is done, the default display (WDSentinel and IP address) appears on the LCD. For more information, see [Microsoft Online Help](#).

7

Best Practices

- Setting up the WD Sentinel DX4000
- Setting up Client Computers
- Using the WD Sentinel DX4000 Efficiently
- Replacing Drives
- Shutting Down

The following practices help you use the WD Sentinel DX4000 and protect your data efficiently and safely.

Setting up the WD Sentinel DX4000

- Change the default name of WD Sentinel to something unique. This avoids conflicts when another WD Sentinel server is added to your network in the future.
- Make sure Ethernet 1 and Ethernet 2 are on the same network subnet.
- Add the server to your domain. This allows users to use the same login and password for both the Launchpad and their computer.
- If you decide to lock the drives, make sure the password is stored in a safe place.
- Set user password policy to at least medium security.
- Enable Microsoft Automatic Updates to find and apply the latest Microsoft software update.
- Enable WD Automatic Updates to find and apply the latest WD software update.
- Set up Automatic Alert Notification for real-time notifications of any problems with the WD Sentinel server.
- Set up Remote Web Access using Ports 443 and Port 80. If your router or IP provider blocks these ports, you may need to consult with your IP provider for assistance.
- **Do not remove the Windows page file!** Some critical functions use the system's paging file. Removing the page file can potentially leave your system unusable with the possibility of data loss. To maintain the reliability of your system and its redundant resources, do not modify the paging file whatsoever.

Setting up Client Computers

- Before loading the Connector software to add a computer to the WD Sentinel server for backup, be sure that the computer's operating system is fully up-to-date.
- When adding client computers to the WD Sentinel server, it is best not to have any backups active.

Using the WD Sentinel DX4000 Efficiently

- The WD Sentinel server has many jobs to perform. Share data during business hours, and back up the computers during hours of inactivity. Keep the server powered on 24/7 to do its work.

Replacing Drives

- The online removal of a drive forces a rebuild when the drive is replaced. Until the rebuild is complete, the RAID system is degraded and unrecoverable failure will occur should another drive be removed. Only remove one drive at a time between rebuilds.
- Avoid pulling a drive out unless there is a failure.
- When a drive needs replacement, the WD Sentinel server is still functional but subject to a second drive failure that would result in the loss of data. To minimize this vulnerable time, a good practice is to have another drive ready to replace the failed drive.

Sharing Files with External Users

- Create Employee-Specific Private Folders/Assign Permissions—Depending on the nature of your business and organizational structure, you may want to create a shared folder for each employee and give the respective employee Read/Write permissions for that folder.
- Create Shares for Vendors or Clients/Access Remotely—The built-in Remote Web Access feature enables collaboration on files and data not only among your employees but also with your clients and vendors.

As a best practice, create a unique user account for each client and vendor you want to exchange data with and create a dedicated Shared Folder for each such external user. To prevent giving external users access to your sensitive data, make sure that the user accounts you create have the appropriate permissions for only the folders you have created for them.

To start collaborating with your external users, just provide them with the domain address of your WD Sentinel server and their user name and password.

Shutting Down

- Unclean shutdowns are hard on RAIDed systems. The WD Sentinel server recognizes an unclean shut down and upon the reapplication of power, begins a long sequence of examining the RAID for errors and bringing the RAID configuration back into alignment. This sequence can take many hours. To avoid this situation and to assure that the unit always experiences clean shutdowns and the best data integrity, use an Uninterruptible Power Supply (UPS).

Note: Performance is affected during a RAID rebuild and verification.

- Before shutting down the server, stop any backups currently running.
- To avoid possible corruption, do not unplug the power from the unit while it is running.

8

Troubleshooting

First Steps Checklist Specific Problems and Corrective Actions

For any issue, first ensure that you are using the latest firmware for the WD Sentinel server. See “Updating Software” on page 24 for instructions.

First Steps Checklist

- Is the power supply plugged in to the wall outlet and the drive?
- Are all cables correctly connected and secured?
- Is the power on? If not, see “LEDs” on page 12.

Specific Problems and Corrective Actions

The following section contains specific problems that may arise during the use of the WD Sentinel server and provides possible solutions.

LEDs do not light up

1. Make sure the power cord is connected correctly.
2. Make sure that the wall outlet has power. Test it by plugging in another device.
3. Confirm the network cable is properly connected to the WD Sentinel server and the network switch or router.
4. Make sure the network switch or router has power.
5. Use a different network cable and port on the network switch or router. Temporarily swapping the WD Sentinel’s cable port with a working network device may identify any failing cables and ports.

Connecting to Shared Folders on a WD Sentinel server from a Windows PC on which Launchpad is not installed

1. Right-click **(My) Computer** and select **Map Network Drive**.

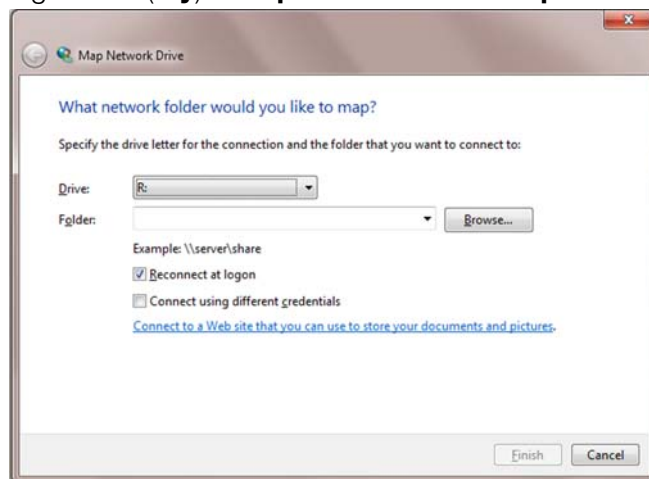

2. From the **Drive** drop-down list, choose the letter that you want the WD Sentinel server to have in **(My) Computer**.

3. Click **Browse** to find the folder that you want to map, or type the path to the server using the format \\ServerName\FolderName. For example, if the share is called Documents, and your server is called MyServer, you would enter \\MyServer\Documents.
4. If you want the drive to reconnect whenever the computer is rebooted, click the **Reconnect at logon** check box.
5. Click **Finish**.

Cannot access Windows PCs via Remote Access

Internet Explorer 8 or 9 is required to access a Windows PC using the Remote Web Access feature of the WD Sentinel server. There is an Active X Client requirement that comes standard with these browsers. For more information, see *Knowledge Base Answer ID 8578*.

9

Regulatory and Warranty Information

Regulatory Compliance
Obtaining Service
Limited Warranty

Regulatory Compliance

FCC Class B Information

This device has been tested and found to comply with the limits of a Class B digital device, pursuant to Part 15 of the FCC Rules. These limits are designed to provide reasonable protection against harmful interference in a residential installation. This unit generates, uses, and can radiate radio frequency energy and, if not installed and used in accordance with the instructions, may cause harmful interference to radio or television reception. However, there is no guarantee that interference will not occur in a particular installation. Any changes or modifications not expressly approved by WD could void the user's authority to operate this equipment.

The following booklet, prepared by the Federal Communications Commission, may be helpful: *How to Identify and Resolve Radio/TV Interference Problems*. This booklet is Stock No. 004-000-00345-4 available from the US Government Printing Office, Washington, DC 20402.

The provided Ethernet cable must be used between the unit and network connection to comply with FCC Part 15 Class B and EN-55022 Class B.

ICES/NMB-003 Compliance

Cet appareil de la classe B est conforme à la norme NMB-003 du Canada.

This device complies with Canadian ICES-003 Class B.

Safety Compliance

Approved for US and Canada. CAN/CSA-C22.2 No. 60950-1, UL 60950-1-07: Safety of Information Technology Equipment.

Approuvé pour les Etats-Unis et le Canada. CAN/CSA-C22.2 No. 60950-1-07 : Sécurité d'équipement de technologie de l'information.

This product is intended to be supplied by a listed limited power source, double insulated, or direct plug-in power unit marked "Class 2."

CE Compliance for Europe

Verified to comply with EN55022 for RF emission; EN-55024 for Generic Immunity, as applicable; and EN-60950-1 for Safety.

KC Notice (Republic of Korea only)

기종별	사용자 안내문
B 급기기 (가정용방송통신기자재)	이 기기는 가정용 (B 급) 전자파적합 기기로서 주로 가정에서 사용하는 것을 목적으로 하며, 모든 지역에서 사용할 수 있습니다.

Class B Device 1. Please note that this device has been approved for non-business purposes and may be used in any environment, including residential areas.

Environmental Compliance (China)

部件编号	铅 (Pb)	水银 (Hg)	镉 (Cd)	六价铬 (Cr(VI))	多溴联苯 (PBB)
PCBA	X	○	○	○	○
适配器	X	○	○	○	○
RJ45 电缆	○	○	○	○	○
螺丝	○	○	○	○	○
橡胶垫	○	○	○	○	○
金属	○	○	○	○	○
塑料	○	○	○	○	○

○ : 表示部件中不包含相应的物质, 或者含量没有超出 SJ/T 11363-2006 法规中规定的同类物质的最大允许水平。
X : 表示部件中相应物质的含量超出 SJ/T 11363-2006 法规中规定的限度

Obtaining Service

WD values your business and always attempts to provide you the very best of service. If this Product requires maintenance, either contact the dealer from whom you originally purchased the Product or visit our product support website at <http://support.wdc.com> for information on how to obtain service or a Return Material Authorization (RMA). If it is determined that the Product may be defective, you will be given an RMA number and instructions for Product return. An unauthorized return (i.e., one for which an RMA number has not been issued) will be returned to you at your expense. Authorized returns must be shipped in an approved shipping container, prepaid and insured, to the address provided on your return paperwork. Your original box and packaging materials should be kept for storing or shipping your WD product. To conclusively establish the period of warranty, check the warranty expiration (serial number required) via <http://support.wdc.com>. WD shall have no liability for lost data regardless of the cause, recovery of lost data, or data contained in any Product placed in its possession.

Limited Warranty

WD warrants that the Product, in the course of its normal use, will for the term defined below, be free from defects in material and workmanship and will conform to WD's specification therefor. The term of your limited warranty depends on the country in which your Product was purchased. The term of your limited warranty is for 3 years in the North, South and Central America region, 3 years in the Europe, the Middle East and Africa region, and 3 years in the Asia Pacific region, unless otherwise required by law. The term of your limited warranty period shall commence on the purchase date appearing on your purchase receipt. WD may at its discretion make extended warranties available for purchase. WD shall have no liability for any Product returned if WD determines that the Product was stolen from WD or that the asserted defect a) is not present, b) cannot reasonably be rectified because of damage occurring before WD receives the Product, or c) is attributable to misuse, improper installation, alteration (including removing or obliterating labels and opening or removing external enclosures, including the mounting frame, unless the product is on the list of limited user-serviceable products and the specific alteration is within the scope of the applicable instructions, as found at <http://support.wdc.com>), accident or mishandling while in the possession of someone other than WD. Subject to the limitations specified above, your sole and exclusive warranty shall be, during the period of warranty specified above and at WD's option, the repair or replacement of the Product with an equivalent or better Product. The foregoing warranty of WD shall extend to repaired or replaced Products for the balance of the applicable period of the original warranty or ninety (90) days from the date of shipment of a repaired or replaced Product, whichever is longer. The foregoing limited warranty is WD's sole warranty and is applicable only to products sold as new. The remedies provided herein are in lieu of a) any and all other remedies and warranties, whether expressed, implied or statutory, including but not limited to, any implied warranty of merchantability or fitness for a particular purpose, and b) any and all obligations and liabilities of WD for damages including, but not limited to accidental, consequential, or special damages, or any financial loss, lost profits or expenses, or lost data arising out of or in connection with the purchase, use, or performance of the Product, even if WD has been advised of the possibility of such damages. In the United States, some states do not allow exclusion or limitations of incidental or consequential damages, so the limitations above may not apply to you. This warranty gives you specific legal rights, and you may also have other rights which vary from state to state.

GNU General Public License ("GPL")

Firmware incorporated into this product may include third party copyrighted software licensed under the GPL or Lesser General Public License ("LGPL") (collectively, "GPL Software") and not Western Digital's End User License Agreement. In accordance with the GPL, if applicable: 1) the source code for the GPL Software may be downloaded at no charge from <http://support.wdc.com/download/gpl> or obtained on CD for a nominal charge from <http://support.wdc.com/download/gpl> or by calling Customer Support within three years of the date of purchase; 2) you may re-use, re-distribute, and modify the GPL Software; 3) with respect solely to the GPL Software, no warranty is provided, to the extent permitted by applicable law; and 4) a copy of the GPL is included herewith, may be obtained at <http://www.gnu.org>, and may also be found at <http://support.wdc.com/download/gpl>.

Modification of or tampering with the Software, including but not limited to any Open Source Software, is solely at your own risk. Western Digital is not responsible for any such modification or tampering. Western Digital will not support any product in which you have or have attempted to modify the Software supplied by Western Digital.

10

Appendix

Managing iSCSI Storage on the WD Sentinel Server

iSCSI Overview

Internet SCSI (iSCSI) is an industry standard developed to enable transmission of SCSI block storage commands and data over an existing IP network by using the TCP/IP protocol. The encapsulated SCSI commands and data can be transmitted over a local area network (LAN) or a wide area network (WAN). As with traditional SCSI, an iSCSI storage solution requires at least one “initiator” residing on the client computer and at least one “target” residing on the storage server.

Once the connection is established between the iSCSI initiator and the iSCSI target, the operating system on the iSCSI initiator sees the storage as a local storage device that can be formatted, read and written in the usual manner.

Your WD Sentinel server allows you to create and manage iSCSI targets. The iSCSI target provides storage, similar to a local hard disk drive, but is accessed over a network rather than locally. The iSCSI target is protected by the underlying RAID structure of the WD Sentinel server.

iSCSI Roles

Initiator: A client computer that accesses storage devices using SCSI commands over an IP network.

Target: A network-attached storage device that provides access to logical disks (which can be created on the WD Sentinel server).

Managing iSCSI Targets

Click the **iSCSI** icon to open the iSCSI page:

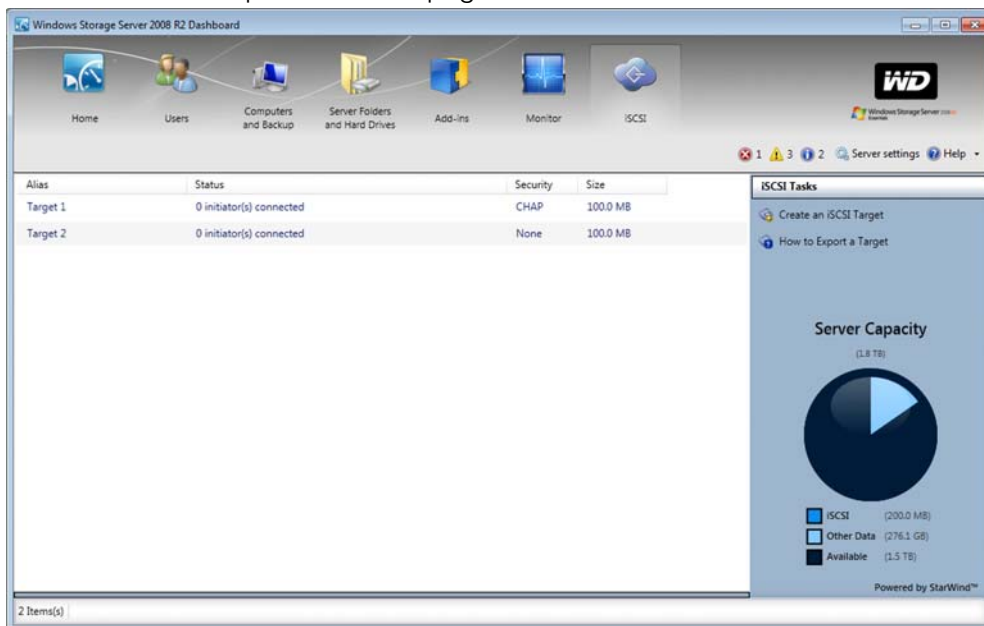

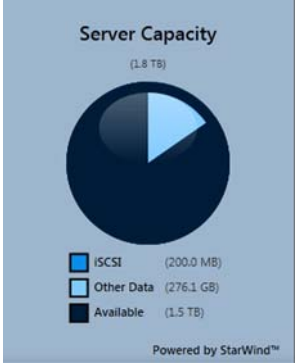
Setting	Description
Alias	The user-friendly name used as an additional descriptive name for the target.
Status	The status of your target. <ul style="list-style-type: none"> • xx initiators connected. • Disabled
Security	The assigned security for the target. <ul style="list-style-type: none"> • None: No security has been assigned to this target • CHAP: Challenge Handshake Authentication Protocol (CHAP) security has been assigned to the target.
Size	The size of the target (e.g., 4, GB, 1 TB)
Server Capacity	Displays the total amount of space on your server and how it is distributed (i.e., available server space; used server space). <div style="text-align: center;">  <p>Server Capacity (1.5 TB)</p> <ul style="list-style-type: none"> iSCSI (200.0 MB) Other Data (276.1 GB) Available (1.5 TB) <p>Powered by StarWind™</p> </div>

Create an iSCSI Target

To create an iSCSI Target that can be used in the WD Sentinel DX4000 server:

1. Click **Create an iSCSI Target** in the iSCSI Tasks pane. The New iSCSI Target window appears.

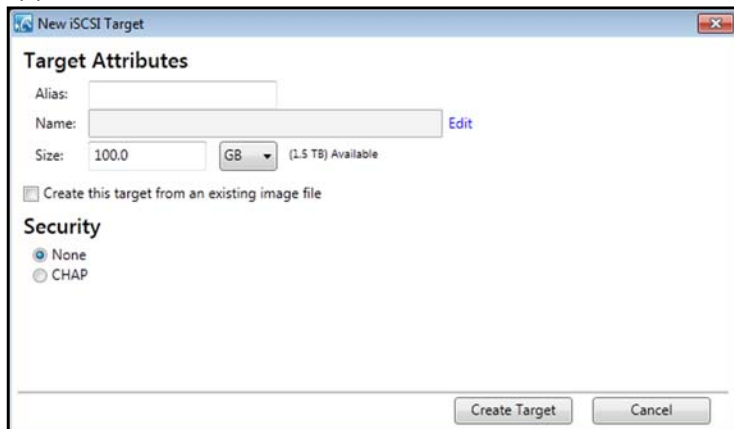

2. In the Alias field, enter an alias for your target. The alias should be a descriptive name for your target.
3. In the Size field, enter the size of your target, then select the unit of information (e.g. KB, MB, GB, TB) from the pull-down menu.

Note: Available space displays to the right of this field.

- Click **Create this target from an existing image file** to create a target from an existing image file.

Note: Use this step only if you have an existing iSCSI target image file.

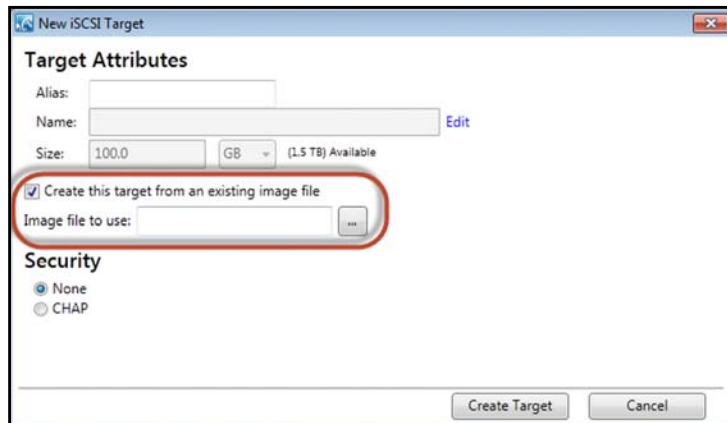

- Select the ... button.
 - On the “Image file to use:” window, navigate to the location of your target image file, then click **Open**.
- Select the security type for your target.

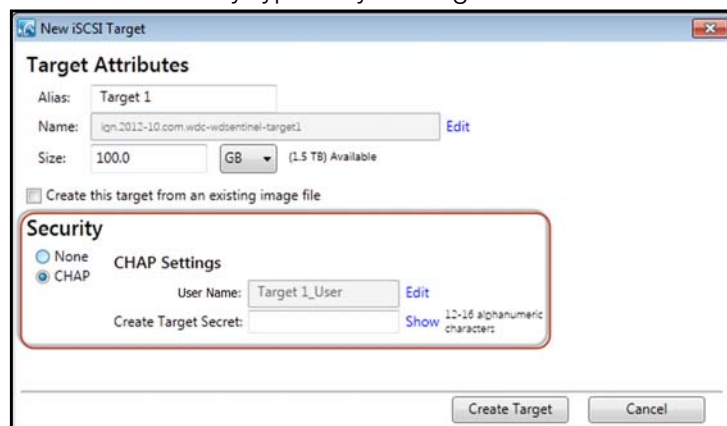

- **None:** Does not assign security for your target.
 - **CHAP:** Assigns Challenge Handshake Authentication Protocol (CHAP) security to your target.
 - If you'd like to change your User Name, click **Edit**. Note that the name must match your initiator CHAP name.
 - Enter your Target Secret. The Target Secret is a security key that must be between 12 to 16 alphanumeric characters.
- Click **Create Target**.

Edit an iSCSI Target

- On the iSCSI Tasks pane, click **Edit Target Settings**.
- Modify the required and optional settings as desired.
- Click **Modify Target**.

Disable an iSCSI Target

Note: Disabling your iSCSI Target temporarily suspends the target, but does not remove it. If you'd like to permanently remove the target, See "Deleting an iSCSI Target" on page 70.

1. In the iSCSI tab, select the target you'd like to disable.
2. In the iSCSI Tasks pane, click **Disable Target**. The Disable a Target message appears.



3. Click **Disable Target**. Disabled now displays in the Status column.

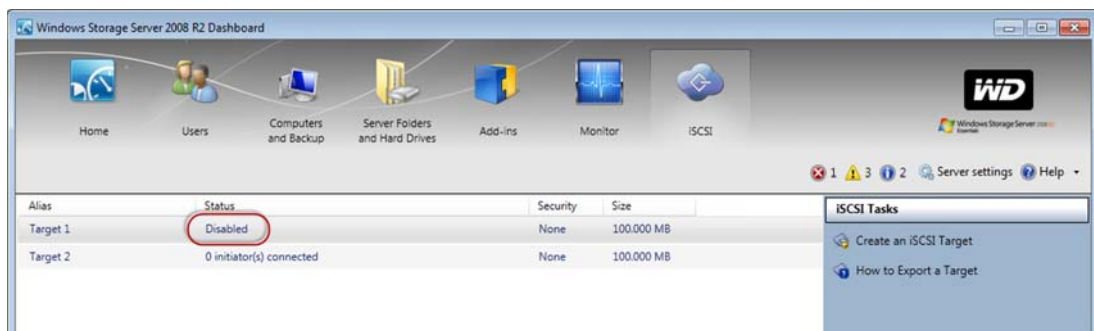

Enabling an iSCSI Target

1. In the iSCSI tab, select the disabled Target you'd like to enable.
2. In the iSCSI Task pane, click **Enable Target**. Your target is now enabled.

Deleting an iSCSI Target

WARNING! Deleting your iSCSI Target completely removes the target. If you'd like to temporarily disable the target, See "Disable an iSCSI Target" on page 70.

1. In the iSCSI tab, select the target you'd like to delete.

- In the Task Pane, click **Delete Target**. The Delete a Target message displays.

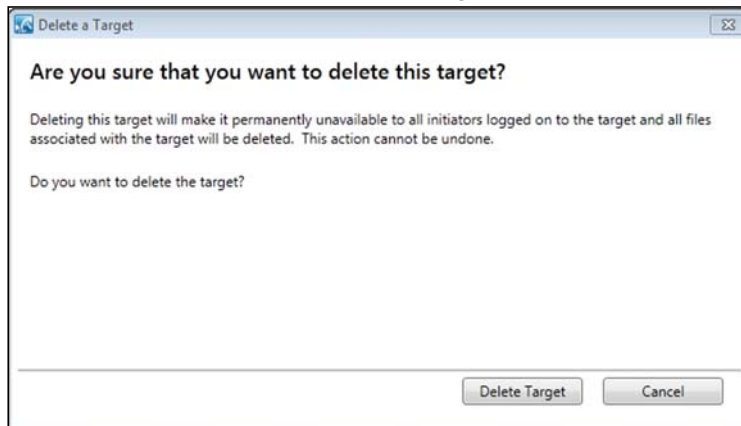

- Click **Delete Target**. Your Target is deleted and removed from the iSCSI target list.

Exporting an iSCSI Target

- On your desktop, open Windows Explorer.
- Under Network, select your WD Sentinel device.
- Select the folder to which you've saved your iSCSI Target image files (usually the Server>TargetImageFiles folder).
- Right-click the target you'd like to export and select **Copy** from the menu.
- Navigate to a different folder.
- Right-click in the folder and select **Paste**. Your iSCSI Target image file is now "exported" to a different folder.

Note: The target image files will have the same name as the iSCSI target you just copied and will have a ".img" file extension.

Importing an iSCSI Target

To import an iSCSI Target into your WD Sentinel, follow the steps outlined in "Create an iSCSI Target" on page 68, following step 4 (selecting the Create this target from an existing image file checkbox) to import your iSCSI target.

Glossary

CIFS—Common Internet File System. The recommended file sharing protocol for Windows platform allows users to access shares through My Network Places. Mac OS X or later also supports the CIFS protocol. See also Protocol.

CLIENT COMPUTER—A computer that accesses services made available by a server computer.

DHCP—Dynamic Host Configuration Protocol. A protocol for assigning IP addresses to devices on a network. With dynamic addressing, a device can have a different IP address each time it connects to the network. In some systems, the device's IP address even changes while it is still connected. DHCP also supports a mix of static and dynamic IP addresses. See also Protocol.

DLNA—Digital Living Network Alliance. The group of consumer electronics, computing industry, and mobile device companies that sets standards for product compatibility, thus enabling users to share content in their home.

DMA— Digital Media Adapter. A device that gives home entertainment devices the ability to transfer media such as music, photos, videos to and from other devices over the network.

DNS—Domain Name Service. A system that allows a network name server to translate text host names into numeric IP addresses used to uniquely identify any device connected to the Internet.

ESD—Electrostatic discharge.

Ethernet—A standard method of connecting computers to a Local Area Network (LAN).

File Transfer Protocol (FTP)—A network protocol used to transfer data from one computer to another through a network. FTP is a popular choice for exchanging files independent of the operating systems involved.

GreenPower™ Technology—Engineering technology developed by WD to bring more energy-efficient hard drive options to our customers. WD hard drives with GreenPower technology yield average power savings of 4-5 watts over competitors' drives while maintaining solid performance.

Host—The computer to which other computers and peripherals connect.

Host Interface—The point at which a host and a drive are connected to each other.

Host Transfer Rate—The speed at which a host computer can transfer data across an interface.

HTTP—Hypertext Transfer Protocol. Protocol used by the World Wide Web to transfer information between servers and browsers. See also Protocol.

HTTPS—Hypertext Transfer Protocol over Secure Socket Layer. A protocol that provides a more secure means of configuring your device than HTTP, but may affect the responsiveness of the user interface. All traffic between the managing computer and the WD Sentinel server is encrypted. See also Protocol.

Hub—In a network, a device joining communication lines at a central location, providing a common connection to all devices on the network.

Interface—A hardware or software protocol to manage the exchange of data between a device and a computer; the most common ones are EIDE (also known as PATA), SATA, and SCSI. See also Protocol.

IP—Internet Protocol. A system that controls how data messages are separated into packets, routed from the sender, and reassembled at the destination. See also Protocol.

IP Address—A 32-bit, binary number that uniquely identifies a computer connected to the Internet.

iSCSI —Internet Small Computer System Interface. iSCSI is an IP-based storage networking standard for linking data storage facilities.

iTunes—An audio playback program used to import songs and other media files from your hard drive or WD Sentinel server drive.

LAN— Local Area Network. A system in which computer users in the same company or organization are linked to each other and often to centrally-stored collections of data in LAN servers.

LED—Light-emitting Diode. An electronic device that lights up when electricity is passed through it.

Media Server—Device that stores and shares media files (digital audio, digital video, and digital photos).

Media Storage—Device that stores media files (digital audio, digital video, and digital photos).

Multi-user—A system in information technology that enables more than one user to access data at the same time.

NAS—Network Attached Storage. Hard disk storage that is set up with its own network address rather than being attached to the computer that is serving network workstation users.

Network Computer—A computer that communicates with a central data storage facility such as a server or RAID system.

NFS—Network File System. A network file system protocol that allows a user on a client computer to access files over a network as easily as if the network devices were attached to its local disks. Normally associated with UNIX systems. See also Protocol.

NTP—Network Time Protocol. A protocol for synchronizing the clocks of computers and equipment over a network. See also Protocol.

Operating System—Software that allows users and programs installed on your system to communicate with computer hardware such as a hard drive.

Partition—A logical division on a hard drive that the operating system treats as a separate hard drive. Each partition is assigned a unique drive letter.

Port (Hardware)—A specialized outlet on a device for connecting to other devices using a cable or a plug. Ethernet ports, power ports, and USB ports are examples.

Protocol— A convention of data transmission that defines timing, control format, and data representation.

RAID—Redundant Array of Independent Disks. A grouping of hard drives in a single system to provide greater performance and data integrity.

RAID 1 — RAID protocol in which two copies of the data are instantaneously recorded: each on separate hard drives. RAID 1 ensures the protection of users' data because in the event that one of the hard drives fails, the other hard drive(s) will continue to read and write data until the faulty hard drive is replaced and rebuilt to once again safely mirror the data. See also Mirroring.

RAID 5— For systems with three or more drives, RAID 5 offers fast performance by striping data across all drives. It protects data by dedicating a quarter of each drive to fault tolerance, leaving three quarters of the system capacity available for data storage.

RAM—Random Access Memory. Memory that allows any storage location to be accessed randomly, as opposed to sequential access devices such as tape drives.

ROM—Read-Only Memory. An integrated circuit memory chip containing programs and data that the computer or host can read but cannot modify. A computer can read instructions from ROM but cannot store data in ROM.

Share—An area, similar to a folder or directory, set up to organize files and access them on your network. Shares can be Public, shared with everyone on your network, or Private, shared with only selected users on your network.

SMB—Server Message Block. File-sharing protocol for Windows platform that allows users to access shares through My Network Places. Mac OS X or later also supports the CIFS protocol. See also Protocol.

SMTP—Simple Mail Transfer Protocol. Standard for transferring email across the Internet. See also Protocol.

Streaming Media—Media such as audio, video, and photos that are constantly received while being delivered by a streaming provider.

Striping—The spread of data over multiple hard drives to improve performance. See also RAID 0.

TCP/IP—Transmission Control Protocol/Internet Protocol. A set of protocols for communication over interconnected networks. The standard for data transmission over networks. See also Protocol.

UPnP—Universal Plug n Play. A set of computer network protocols that simplify the implementation of networks in the home by allowing devices to connect seamlessly. See also Protocol.

WAN—Wide Area Network. A computer network that crosses metropolitan, regional, or national boundaries.

Index

A

- About tab 19
- accessing Dashboard 16
- accessing Launchpad
 - Mac computer 35
 - Windows PC 34
- accessing shared folders
 - via network 40
 - via Remote Web Access 41
- accessories 6
- adding storage capacity 33
- Administrator's tasks 14
- alert icons 19
- alerts 21
- automatic backups 43, 48
- automatically updating WD software 25

B

- back view 9
- backing up
 - using Dashboard 45
 - using Launchpad 44
 - Windows PC 42, 44, 45
 - with Time Machine 45
- backups
 - automatic 43, 48
- bare metal restore 48
- basic product information 19
- best practices
 - getting started 19
 - replacing drives 61
 - setting up client computers 60
 - setting up WD Sentinel DX4000 60
 - using efficiently 60
- box contents 5

C

- China RoHS 65
- compliance 64
 - regulatory 64
 - safety 64
- computers
 - connecting 16
 - Remote Web Access 41
- Computers and Backups 20
- Computers and Backups icon 43
- connecting Windows PC to shared folders
 - without Launchpad 62

- cooling fan 21
- Customer Support
 - automatic request 23
 - contacts ii

D

- Dashboard
 - accessing 16
 - tabs 18
 - tasks 18
- description of WD Sentinel DX4000 3
- document conventions 2
- drives
 - compatible 23
 - lock/unlock 23

E

- enabling Remote Web Access 26
- environmental compliance (China) 65
- external users' tasks 14

F

- FCC Class B information 64
- files and folders
 - recovering 48, 49
- front view 9

G

- GNU general public license 66

H

- Health tab 21
- help
 - where to find 13
- Help icon 18
- Home page 18
 - tabs 19
 - tasks 20

I

- ICES/NMB-003 compliance 64
- icon
 - Add-ins 21
 - alerts 19
 - Computer and Backups 20
 - Computers and Backups 43
 - Help 18
 - Launchpad 34
 - Monitor 21
 - navigation 18
 - Server Folders and Hard Drives 20
 - Trash 39
 - User 20

- increasing storage capacity 33
- internal users' tasks 14
- L**
- Launchpad
 - accessing on a PC 34
 - backing up 44
 - icon 34
 - managing 37
 - options 37
 - starting a backup 44
 - uninstalling on a Mac computer 39
 - uninstalling on Windows PC 39
- lock password, changing 24
- M**
- Mac
 - backing up 45
- Mac computer, accessing Launchpad 35
- managing the Launchpad 37
- media library, accessing remotely 42
- Microsoft software
 - updating 25
- Monitor icon 21
- monitoring system health 21
- N**
- navigation icons 18
- network connection health 21
- O**
- office uses 15
- online product registration ii
- operating system requirements 7
- P**
- package contents 5
- password
 - Administrator 14
 - lock/unlock 23
- password and user name 14
- power supplies 21
- product registration ii
- R**
- RAID storage 29, 67
- recovering data
 - PC 48
- recovering the WD Sentinel server 50
- reference resources 12
- registration, online ii
- regulatory compliance 64
- Remote Web Access 26
 - accessing computers and shared folders 41
 - media library 42
 - replacement drives 23
 - replacing a drive 31
 - requirements
 - operating systems 7
 - server recovery 50
 - restore
 - backed up Windows PC data 48
 - restoring data and settings 48, 49
 - RoHS 65
- S**
- safe shutdown 27
- safety compliance 64
- scheduling Automatic Backups
 - Dashboard 43
 - PC 43
 - Time Machine 45
- scheduling WD software updates 25
- server
 - setting up 16
- server folders 20
- server recovery 50
 - requirements 50
- server settings
 - general 26
 - homegroup 26
 - managing 25
 - media 26
- service
 - obtaining 65
- shared folders
 - accessing over the network 40
 - accessing remotely 41
 - Remote Web Access 41
- shutting down safely 27
- specifications 8
- storage 21
 - managing 29, 67
 - RAID 29, 67
 - USB 30, 67
- system health 21
- system temperature 21
- T**
- tabs
 - Home page 19
 - Updating Software 24
- tasks
 - Dashboard 18

- Health 21, 67
- Home page 19
- tasks pane 18
- technical specifications 8
- Technical Support contacts list ii
- temperature 21
- Time Machine
 - backing up using Time Machine 45
- Trash icon 39
- troubleshooting
 - cannot access Windows PCs via Remote Access 63
 - checklist 62
 - drive not connecting to network 62
 - LEDs do not light up 62

U

- Underwriters Laboratories Inc. (UL) 64
- updating Microsoft software 25
- updating WD Software 24
- USB
 - sharing files and folders 30
 - storage 30, 67
- user accounts 14, 20
- user assistance 12
- users
 - external 14
 - internal 14
- Using 34

W

- warning
 - lithium battery 2, 50, 54, 70
 - unclean shutdown 28
- WD Guardian Services 19
- WD limited warranty 66
- WD Sentinel DX4000
 - components 10
 - using locally and remotely 15
- WD Service 65
- WD software
 - automatic updates 25
 - manual updates 24
 - updating 24
- Windows PC
 - backing up 42
 - backing up via Dashboard 45
 - backing up via Launchpad 44
 - restoring 48

Information furnished by WD is believed to be accurate and reliable; however, no responsibility is assumed by WD for its use nor for any infringement of patents or other rights of third parties which may result from its use. No license is granted by implication or otherwise under any patent or patent rights of WD. WD reserves the right to change specifications at any time without notice.

Western Digital, WD, and the WD logo are registered trademarks in the U.S. and other countries; and WD Sentinel and WD Guardian are trademarks of Western Digital Technologies, Inc. Other marks may be mentioned herein that belong to other companies.

© 2012 Western Digital Technologies, Inc. All rights reserved.

Western Digital Corporation
3355 Michelson Drive, Suite 100
Irvine, California 92612 U.S.A.

4779-705064-A03 December 2012

Free Manuals Download Website

<http://myh66.com>

<http://usermanuals.us>

<http://www.somanuals.com>

<http://www.4manuals.cc>

<http://www.manual-lib.com>

<http://www.404manual.com>

<http://www.luxmanual.com>

<http://aubethermostatmanual.com>

Golf course search by state

<http://golfingnear.com>

Email search by domain

<http://emailbydomain.com>

Auto manuals search

<http://auto.somanuals.com>

TV manuals search

<http://tv.somanuals.com>