

INSTALLATION INSTRUCTIONS AND OWNER'S MANUAL



idrive **PRO**™

FOR TORQUEMASTER TECHNOLOGY

for TORQUEMASTER®/
TORQUEMASTER® PLUS
Models: 3790/3790-Z
Installation Instructions
and Owner's Manual



WARNING PHOTOELECTRIC EYES ARE NOT REQUIRED ON WAYNE-DALTON SERIES 9000 AND MODEL 5120 AND 5140 DOORS. ALL OTHER DOORS, WHICH DO NOT HAVE PINCH-RESISTANT SECTION JOINTS, REQUIRE PHOTOELECTRIC EYES TO PREVENT POSSIBLE SEVERE OR FATAL INJURY.

USE OF THIS MANUAL

WHEN INSTALLING A NEW DOOR WITH AN IDRIVE®:

If you just finished installing a new garage door along with an *idrive*® opener, then proceed with these instructions beginning with Step 14 on page 21. If you were referred to these instructions as part of a new door installation, then proceed with these instructions beginning with Step 1 on page 7.

Integrated Z-Wave® technology
Ready for your home
control network
On select models

IMPORTANT NOTICE!

To avoid possible injury, read the enclosed instructions carefully before installing/operating this garage door opener. Pay close attention to all warnings and notes. This manual **MUST** be attached to the wall in close proximity to the garage door opener.

**Wayne®
Dalton**
GARAGE DOORS & OPENERS

Package Contents

NOTE: Depending on the opener model purchased, some accessories listed will not be supplied.

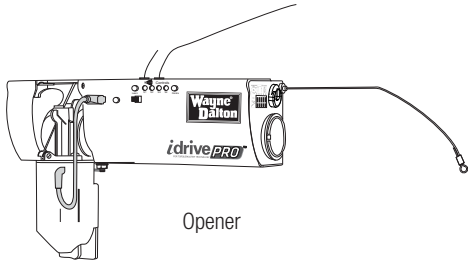

Opener

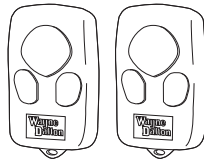

Key chain/Visor Transmitter (2)

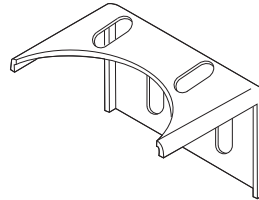

Mounting Bracket

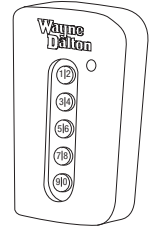

5 Button Wireless Keyless Entry

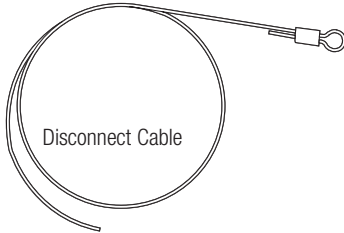

Disconnect Cable



Deluxe Multi-function Wireless Wall Station



Disconnect Handle



"S" Hook



Cable Clips (4)



Jumper
(Optional for Safety Sensors)



Owner's Manual

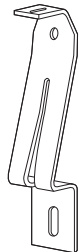

Disconnect Handle Bracket

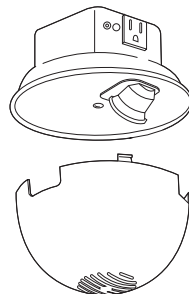

Security Light with Diffuser
(Not available with model #3790-Z)

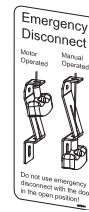

Emergency Disconnect Label



Entrapment Label

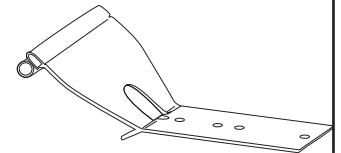

Lock Arm Assembly

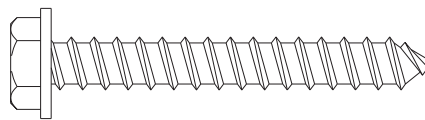

1/4" x 2" Hex Head Lag Screws (2)

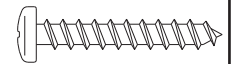

#6 x 7/8" Phillips Pan Head Screws (4)

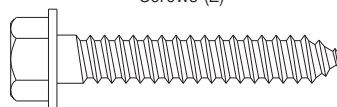

1/4" x 1-1/2" Hex Head Lag Screws (4)

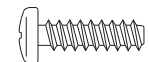

#6-20 x 1/2" Phillips Pan Head Screw (1)



Installation DVD

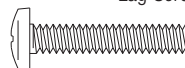

#6-32 x 3/4" Phillips Pan Head Screw (1)
(For Light Fixture)

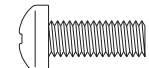

5mm x .8mm x 12mm Phillips Pan Head Screw (1)
(For Lock Arm)

Please Do Not Return This Product To The Store. Call Us Directly! Our Trained Technicians Will Answer Your Questions and/or Ship Any Parts You May Need. You can reach us Toll Free at **1-888-827-3667** for Consumer Assistance or online at **www.wayne-dalton.com**

PRE-INSTALLATION INSPECTION OF YOUR GARAGE DOOR **PRIOR TO TORQUEMASTER® IDRIVE® INSTALLATION**

Congratulations, you have just purchased one of the world's safest garage door openers! By design, this opener will detect obstructions and reverse rather than force the door through obstructions. **To ensure your new *idrive*® opener works as intended, your garage door must be installed and balanced properly.**

WHEN INSTALLING A NEW DOOR WITH AN IDRIVE®:

If you just finished installing a new garage door along with an *idrive*® opener, then proceed with these instructions beginning with Step 14 on page 21. If you were referred to these instructions as part of a new door installation, then proceed with these instructions beginning with Step 1 on page 7.

WHEN INSTALLING AN IDRIVE® ON AN EXISTING DOOR WITH TORQUEMASTER® OR TORQUEMASTER® PLUS:

Before installing the *idrive*® opener, open and close you door manually to ensure that it operates smoothly from top to bottom. A properly balanced door should not take a lot of effort to open or close by hand. The door should stay in the open and in the closed position without drifting down or creeping up. If a door opens fast going up, the door may need spring tension reduced. If the door drops fast going down, the door may need spring tension increased.

If the operation of the door does not meet these criteria, you need to adjust the spring balance per your door's Installation Instructions and Owner's Manual or call a professional installer to make adjustments before installing *idrive*®.

If the door operates properly, check and record your Torquemaster® counterbalance spring settings (for Torquemaster Plus spring settings, see warning tag(s) attached to the end brackets or refer to your door Installation Instructions and Owner's manual). Then proceed with unwinding of the spring(s) for installation of your *idrive*®, carefully following the instructions in the appropriate STEP R1 of your *idrive*® Installation Instructions and Owner's Manual. After the *idrive*® is installed on the Torquemaster® tube, rewind the Torquemaster® or Torquemaster® Plus to the previously recorded settings.

Instruction manuals are available for download on **www.wayne-dalton.com**. Use the web site to also find the location of your nearest professional dealer.

Check out the new *idrive*® installation video at www.wayne-dalton.com

***idrive*® for Torquemaster®**

http://www.wayne-dalton.com/idrive_TorqueMaster.asp

Look for this symbol.



PRE-INSTALLATION INSPECTION

CAUTION! Do not install this opener on your door unless the following requirements are met.

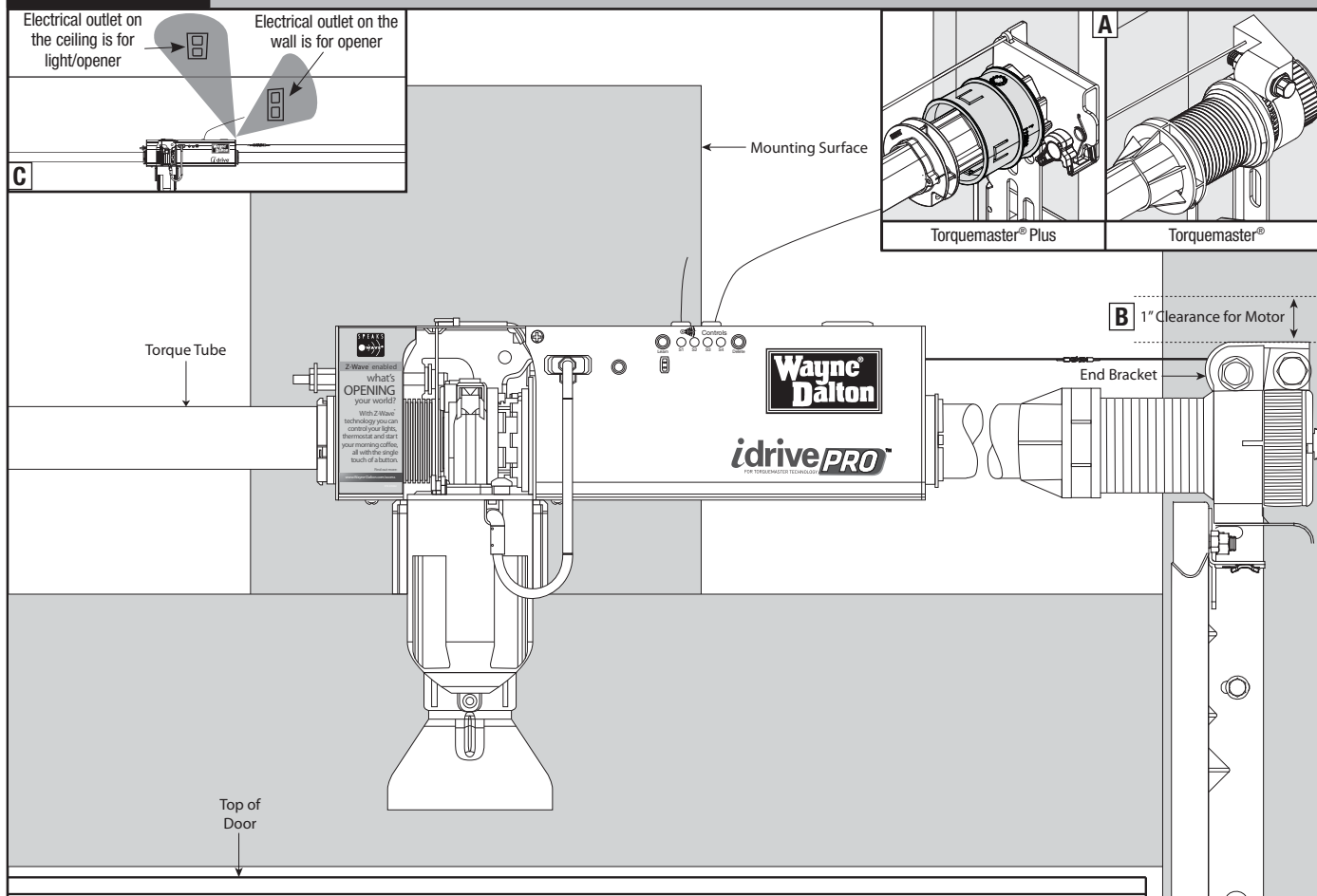

Pre-Installation Inspection

WARNING PHOTOELECTRIC EYES ARE NOT REQUIRED ON WAYNE-DALTON SERIES 9000 AND MODEL 5120 AND 5140 DOORS. ALL OTHER DOORS, WHICH DO NOT HAVE PINCH-RESISTANT SECTION JOINTS, REQUIRE PHOTOELECTRIC EYES TO PREVENT POSSIBLE SEVERE OR FATAL INJURY.

CAUTION: DO NOT INSTALL THIS OPENER ON YOUR DOOR UNLESS THE FOLLOWING REQUIREMENTS ARE MET. USE THE ILLUSTRATION ABOVE AS A VISUAL AID.

- A.** You must have a Wayne-Dalton Torquemaster® or Torquemaster® Plus counterbalance system to install this opener (see A above).
- B.** The motor requires 1" of clearance above the top of the end bracket for Torquemaster and 1-1/4" of clearance above the top of the end bracket for Torquemaster plus.
- C.** Two electrical outlets are recommended for the iDrive® installation. One of these outlets needs to be located less than 6' from the opener. The second outlet, for the light, can be located at a position of your choice.

If, in the event that an electrical outlet is not located within 6' of the opener, contact a local electrician for further options. As a convenience, an electrical outlet is provided on the light fixture. The 6' opener cord can be used with this outlet.
- D.** Your door must not exceed 8' in height.
- E.** The iDrive® opener will only work on sectional doors. Do not install on one-piece doors.
- F.** Your garage door must be properly balanced (door must not be heavy to lift, nor lift by itself).
- G.** Horizontal tracks should be raised 1" above level at rear of Track.
- H.** We do not recommend installing the iDrive® opener on Model 9700 door widths of 16' - 18'.
- I.** Maximum door weight (without spring tension) must not exceed 304 lb.

System Requirements

CAUTION TO REDUCE THE RISK OF INJURY, USE THIS OPENER ONLY WITH THE FOLLOWING DOOR MODELS:

WAYNE-DALTON DOOR MODEL	WAYNE-DALTON SPRING SYSTEM	TRACK (RADIUS)	PHOTOELECTRIC SAFETY SENSORS	LOW HEAD ROOM KIT
9000 SERIES, 5120 & 5140	Torquemaster® Torquemaster® Plus	10",12",14",15"	Not Required	Not Required
9000 SERIES, 5120 & 5140	Torquemaster® Torquemaster® Plus	6" Low Head Room	Not Required	P/N 302883 Required
<u>Door Models below require the use of photo eyes.</u>				
8000 SERIES or other doors	Torquemaster® Torquemaster® Plus	10",12",14",15"	P/N's 252118 or 301674 Required	Not Required
8000 SERIES or other doors	Torquemaster® Torquemaster® Plus	6" Low Head Room	P/N's 252118 or 301674 Required	P/N 302883 Required

Tools Needed

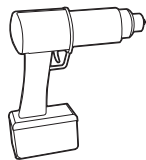

Power Drill

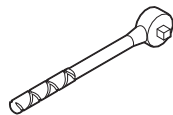

Ratchet Wrench

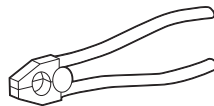

Pliers/Wire Cutters

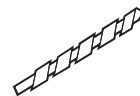

3/32" Drill Bit

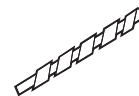

3/16" Drill Bit

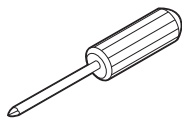

Phillips Head Screwdriver



7/16" Socket

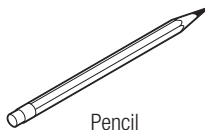

Pencil

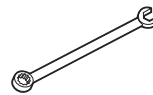

7/16" Wrench



1/8" Drill Bit



5/64" Drill Bit

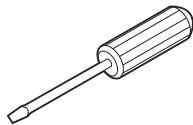

Flat Tip Screwdriver

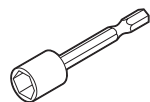

7/16" Socket Driver

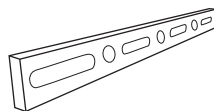

Level

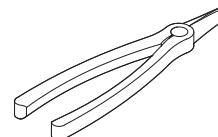

Needle Nose Pliers

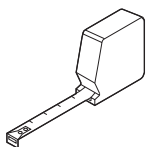

Tape Measure

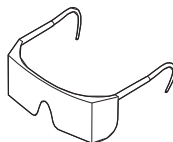

Safety Glasses

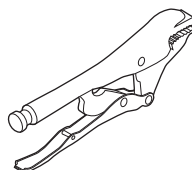

Locking Pliers

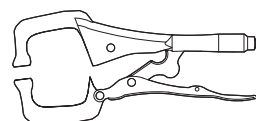

Vice Clamps

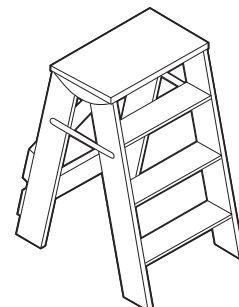

Step Ladder

Please Do Not Return This Product To The Store. Call Us Directly! Our Trained Technicians Will Answer Your Questions and/or Ship Any Parts You May Need. IV
You can reach us Toll Free at **1-888-827-3667** for Consumer Assistance or online at **www.wayne-dalton.com**

Table of Contents

Package Contents	I.
Pre-Installation Inspection	II, III
Tools Needed	IV.
Important Safety Instructions	V.
Retro-Fit Installations	1-6.
<i>zdrive</i> [®] for Torquemaster [®] Installation	7-21.
Pre-Operation	21-32.
Operation	33-38.
Maintenance	38.
Power Connection- Permanent Wiring Option	39.
Programming Wireless Wall Station(s) or Transmitter(s) to Opener	40.
Troubleshooting	41-42.
Warranty	43.
Customer Service Number	44.
Drill Template	44.

Definition of key words used in this manual:

WARNING

INDICATES A POTENTIALLY HAZARDOUS SITUATION WHICH, IF NOT AVOIDED, COULD RESULT IN SEVERE OR FATAL INJURY.

CAUTION: PROPERTY DAMAGE OR INJURY CAN RESULT FROM FAILURE TO FOLLOW INSTRUCTIONS.

IMPORTANT: REQUIRED STEP FOR SAFE AND PROPER DOOR OPERATION.

NOTE: Information assuring proper installation of the door.

WARNING

INCORRECT INSTALLATION CAN LEAD TO SEVERE OR FATAL INJURY. FOLLOW THESE INSTRUCTIONS CAREFULLY.

IMPORTANT SAFETY INSTRUCTIONS

1. READ AND FOLLOW ALL INSTALLATION INSTRUCTIONS.

- Do not connect the opener to electrical power until instructed to do so.
- Install the entrapment warning label next to the wall station in a prominent location. Install the emergency disconnect label next to the emergency disconnect.
- Remove all ropes and remove, or make inoperative in the unlocked position, all locks connected to the garage door before installing the opener.
- Do not wear rings, watches or loose clothing when installing or servicing a garage door system.
- It is important that you install all the components supplied with the *zdrive*[®] opener, i.e., wall stations, safety sensors, etc. Use of parts not supplied by Wayne-Dalton Corp. may cause the opener to malfunction and create unsafe conditions.
- Wear safety glasses for eye protection when installing or servicing the opener or door.
- Install opener on a properly balanced and operating garage door. Have a qualified service person make adjustments/repairs to cables, spring assemblies, and other hardware before installing the opener. An improperly balanced door could cause severe injury.
- Where possible, install the opener seven feet or more above the floor. Mount the emergency disconnect six feet above the floor.
- Locate the wall station: (a) within sight of door, (b) at a minimum height of five feet, so small children cannot reach it, and (c) away from all moving parts of the door.
- After installing the opener, the door must reverse when it contacts a 1-1/2" high object (or 2 x 4 board laid flat) on the floor.
- Installation and wiring must comply with local building and electrical codes. Connect the power cord to a properly grounded outlet. Do not remove the ground pin from power cord.

AFTER INSTALLATION IS COMPLETE, FASTEN THIS MANUAL NEAR GARAGE DOOR. PERFORM MONTHLY OBSTRUCTION TEST AND MAINTENANCE AS RECOMMENDED. SEE PAGES 31, 32 AND 38.

INSTALLATION NOTICE: If installing the *idrive*® opener on a door currently installed with Torquemaster® Plus counterbalance system, start the installation with Step: R1 below. For Torquemaster® counterbalance system, start the installation with Step R1 on page 3.

Retro-Fit TorqueMaster® Plus

R1

Retro-Fit Installation Drum Wrap & End Bracket Removal

Tools Needed:
Step Ladder
Flat Blade
Screwdriver

IMPORTANT! RIGHT AND LEFT HAND IS ALWAYS DETERMINED FROM INSIDE THE BUILDING LOOKING OUT.
NOTE: Warning tag removed for illustration clarity.
Starting on the right hand side, unlock the drum wraps from the cable drums. Un-snap hinged latch. PULL COUNTERBALANCE CABLE SLIGHTLY OUTWARD FROM THE JAMB to allow hinged latch to pass to the left of the cable. Pry radially outward with a small screwdriver on the three tabs (one at a time) while maintaining pressure on drum wrap in direction shown to remove. Repeat drum wrap removal for left side.

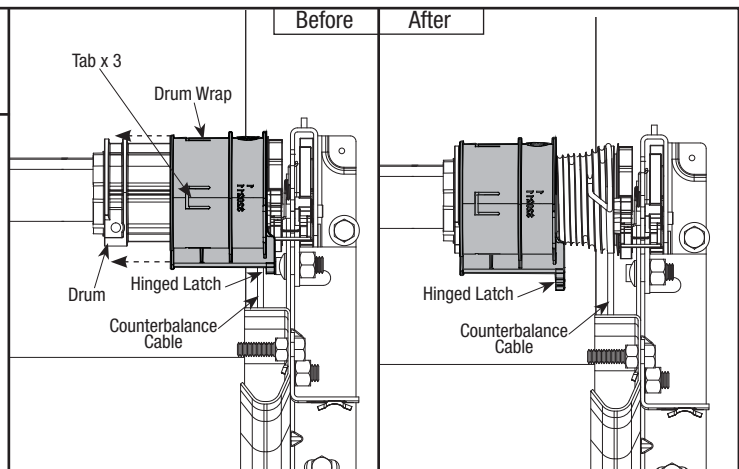

R2

Spring Tension Removal

Tools Needed:
Ratchet Wrench
5/8" Socket
3" Extension
Gloves
Step Ladder

Counterbalance spring tension must be relieved before removing any hardware.

⚠ WARNING

A POWERFUL SPRING RELEASING ITS ENERGY SUDDENLY CAN CAUSE SEVERE INJURY.

Starting with the right hand side, ensure pawl knob is in upper position. Place a ratchet with a 5/8" socket on the winding shaft.

NOTE: A 3" extension is also recommended for added clearance from the horizontal angle.

To remove spring tension, ensure the ratchet and socket is set so that it will add tension (counter clockwise) on the right hand side and (clockwise) on the left hand side. Rotate ratchet to relieve pressure between the pawl and the ratchet wheel. Push in on the pawl to allow the ratchet wheel teeth to pass by.

NOTE: In the event of a broken spring, it might not be necessary to unwind spring(s).

IMPORTANT! BE PREPARED TO HOLD THE FULL TENSION OF THE SPRING.

Gently let the ratchet rotate upward, while watching the number of teeth on the ratchet wheel pass by the pawl. Remove 3/10 of a turn (watch the 3 teeth of the ratchet wheel pass the pawl). Release the pawl to allow it to engage with the ratchet wheel. Repeat this process until all spring tension has been removed from spring(s). Cables should be loose and the torque tube should be free to rotate in either direction.

IMPORTANT! SPRING(S) ARE FULLY UNWOUND WHEN COUNTERBALANCE CABLES HAVE NO TENSION.

IMPORTANT! DO NOT USE AN IMPACT GUN TO UNWIND THE SPRINGS.

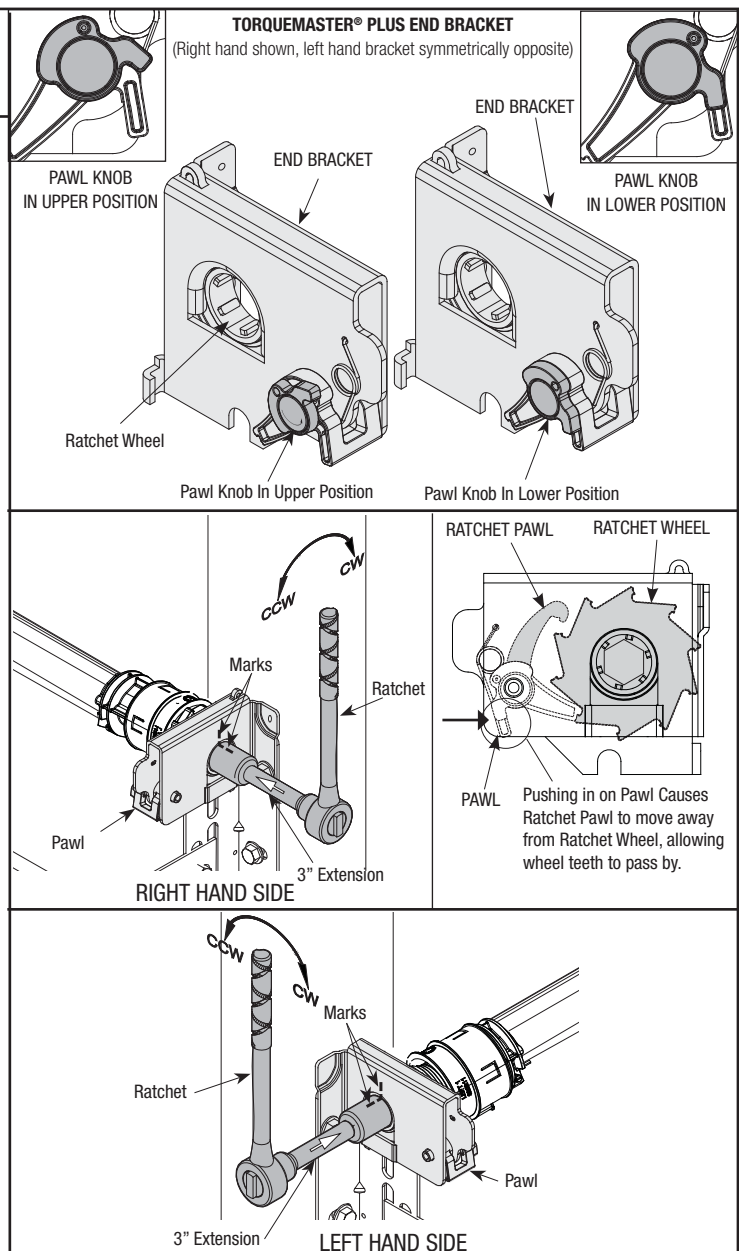

R3

End Bracket Removal

Tools Needed:

Power Drill
7/16" Socket Driver
1/2" Wrench
Step Ladder

To remove end brackets, start with the right hand end bracket and remove the lower lag screw and carriage bolt.

Repeat for left hand end bracket.

CAUTION: THE WINDING SHAFT MAY ROTATE WHEN REMOVING THE END BRACKET AND GEAR.

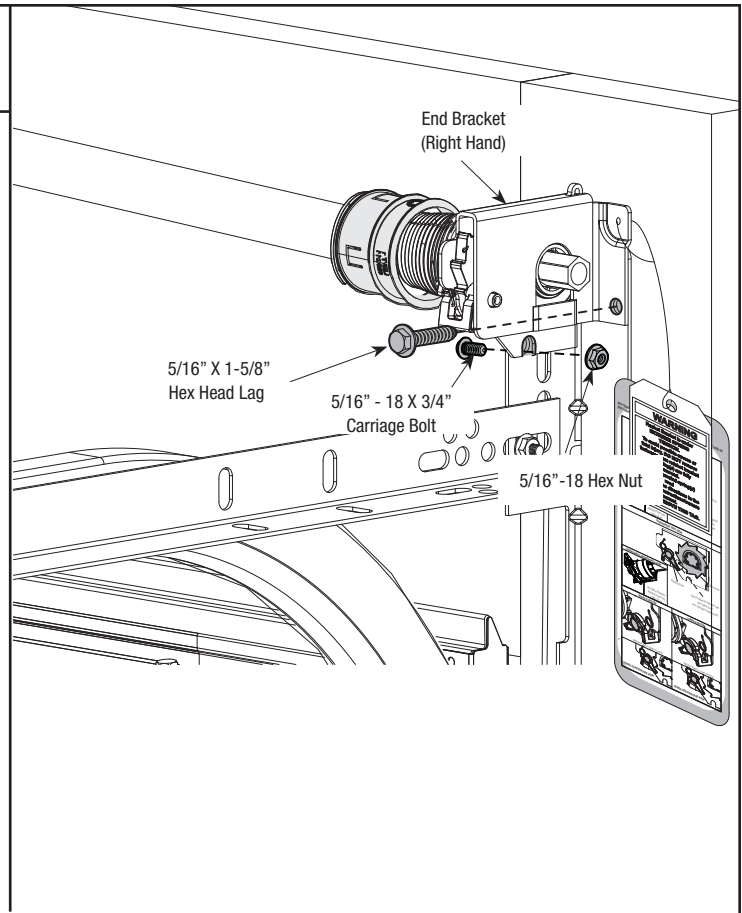

R4

Center Bracket & Cable Drum Removal

Tools Needed:

Power Drill
7/16" Socket Driver
Step Ladder

To remove the cable drum/center bracket, follow the steps below:

a. Remove the two 1/4" lag screws from the center bracket. slide center bracket to the right side of the torque tube.

Lift the right side of the torque tube up and slide the cable drum and center bracket off the end of the torque tube. discard the center bracket.

b. Drape the cable drum over the flagangle by the counterbalance cable and re-align the groove in the winding shaft with the round notch in the flagangle.

Once aligned, lower the winding shaft and torque tube onto the flagangle.

Repeat cable drum removal for left side.

After completing this step, continue with Step R5 on page 5.

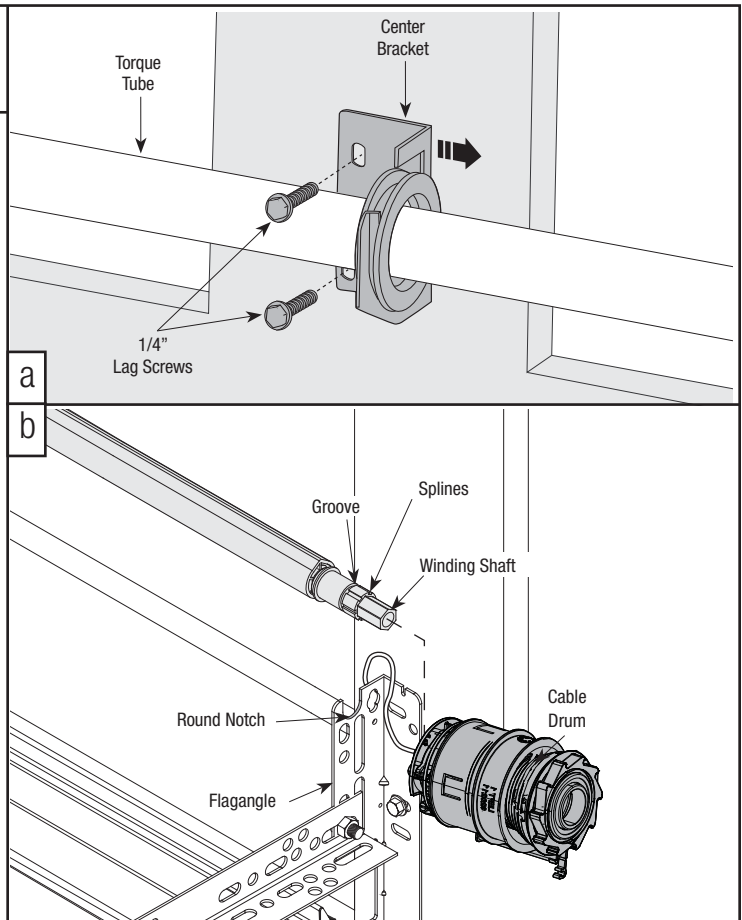

R1

Retro-Fit Installation Spring Tension Removal

Tools Needed:
7/16" Wrench
Power Drill
7/16"
Socket Driver
Step Ladder

Counterbalance spring tension must be relieved before removing any hardware.

⚠ WARNING

A POWERFUL SPRING RELEASING ITS ENERGY SUDDENLY CAN CAUSE SEVERE, EVEN FATAL INJURY.

NOTE: Warning tag removed for illustration clarity.

Place door in the fully closed position and remove drum wraps from cable drums (if installed).

Using a 7/16" wrench, loosen lock nut on the back of the end bracket. Using a power drill (high torque/gear reduced to 1300 RPM preferred), with a 7/16" socket driver, unwind the right hand winding bolt counter clockwise until the counter cover shows "0" (zero). If the door has two springs, repeat this process for the left hand side.

NOTE: A door with only one spring will not have a counter assembly on the left hand side.

NOTE: Spring(s) is/are fully unwound when counterbalance cables have no tension.

CAUTION: DO NOT USE AN IMPACT GUN TO UNWIND THE SPRINGS!

NOTE: It is recommended that cable drums and end bracket assemblies get updated to current designs for optimal performance. current end brackets are made of metal instead of plastic, and counter cover and worm gears are made of grey plastic, instead of black and white plastic. If new parts are required, contact Wayne-Dalton customer service.

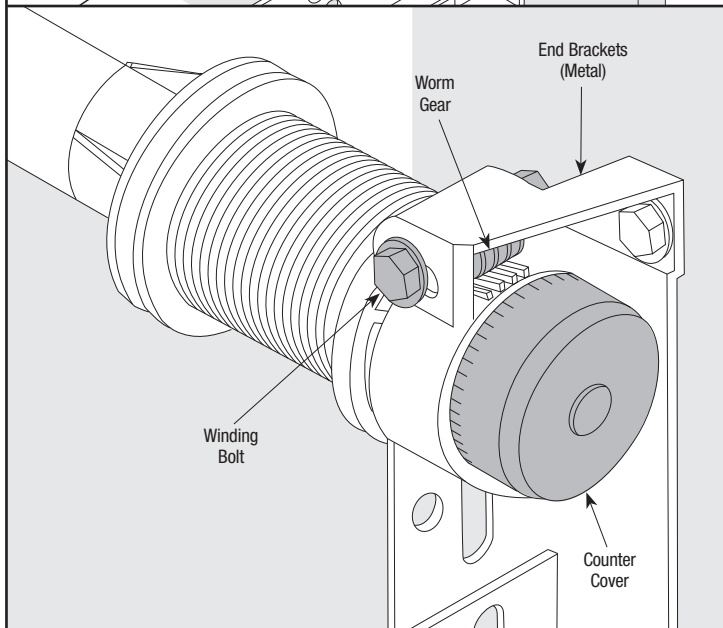
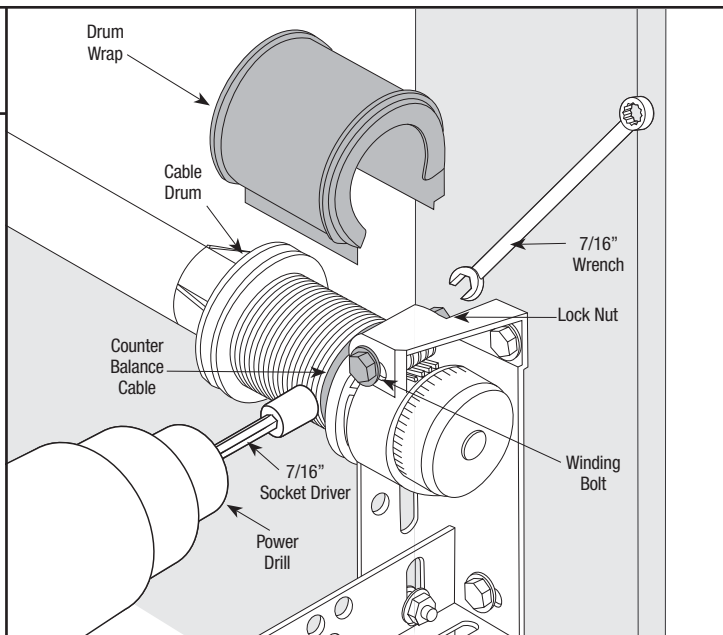

R2

Right Hand Counter Removal

Tools Needed:
Flat Tip
Screwdriver
Step Ladder

IMPORTANT! RIGHT AND LEFT HAND IS ALWAYS DETERMINED FROM INSIDE THE GARAGE LOOKING OUT.

Remove the counter cover. Slide a flat tip screwdriver between the end bracket and the counter gear.

Gently pull the counter gear away from the end bracket. If the door has two springs, repeat this process for the opposite side.

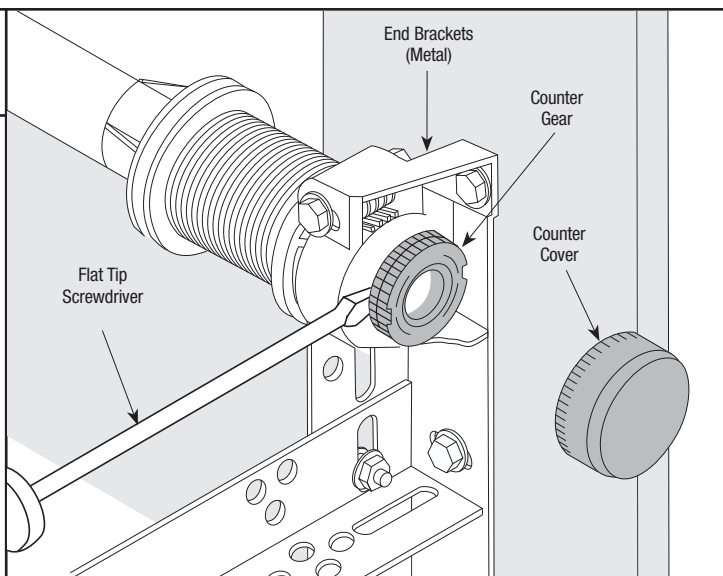

R3

End Bracket Removal

Tools Needed:
Locking Pliers
Phillips Head Screwdriver
Flat Tip Screwdriver
Power Drill
7/16" Socket Driver
Step Ladder

To remove the end brackets, follow the steps below starting with the right hand end bracket first:

- Remove the upper lag screw from the end bracket.
- Attach a pair of locking pliers to the upper portion of the end bracket and hold the end bracket steady while removing the lower lag screw. If present, remove and save the #10 phillips head screw.
- Holding the end bracket with the locking pliers, carefully pry the end bracket from the cable drum with a flat tip screwdriver.

Repeat for left hand end bracket.

CAUTION: THE WINDING SHAFT MAY ROTATE WHEN REMOVING THE END BRACKET AND GEAR.

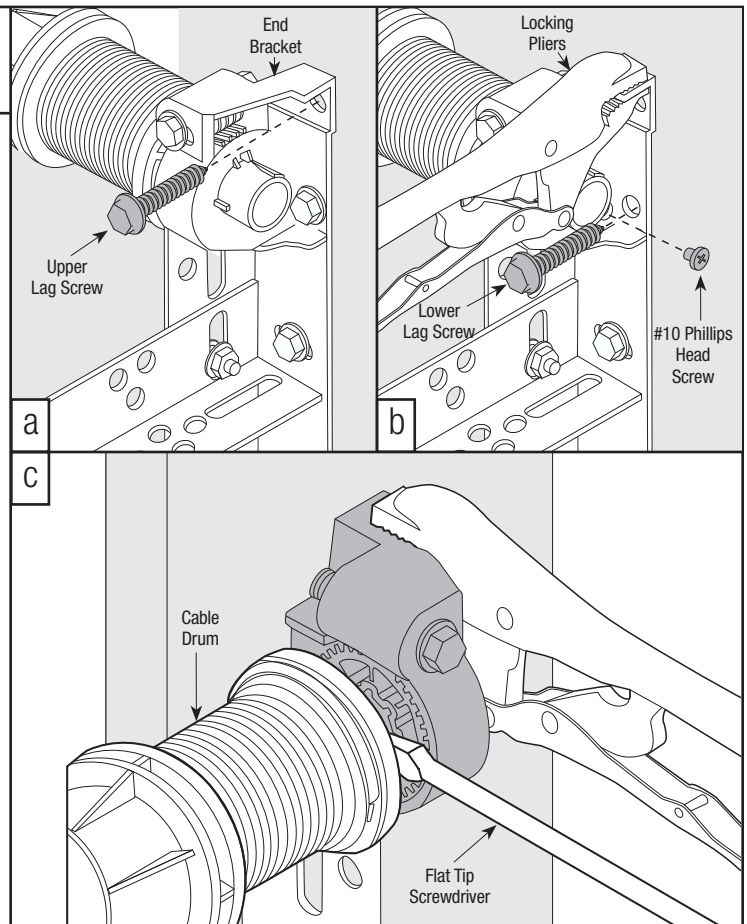

R4

Center Bracket & Cable Drum Removal

Tools Needed:
Power Drill
7/16" Socket Driver
Step Ladder

To remove the cable drum/center bracket, follow the steps below:

- Remove the two 1/4" lag screws from the center bracket. Slide center bracket to the right side of the torque tube.

Lift the right side of the torque tube up and slide the cable drum and center bracket off the end of the torque tube. Discard the center bracket.

- Drape the cable drum over the flagangle by the counterbalance cable and re-align the groove in the winding shaft with the round notch in the flagangle.

Once aligned, lower the winding shaft and torque tube onto the flagangle.

Repeat cable drum removal for left side.

After completing this step, continue with Step R5 on page 5.

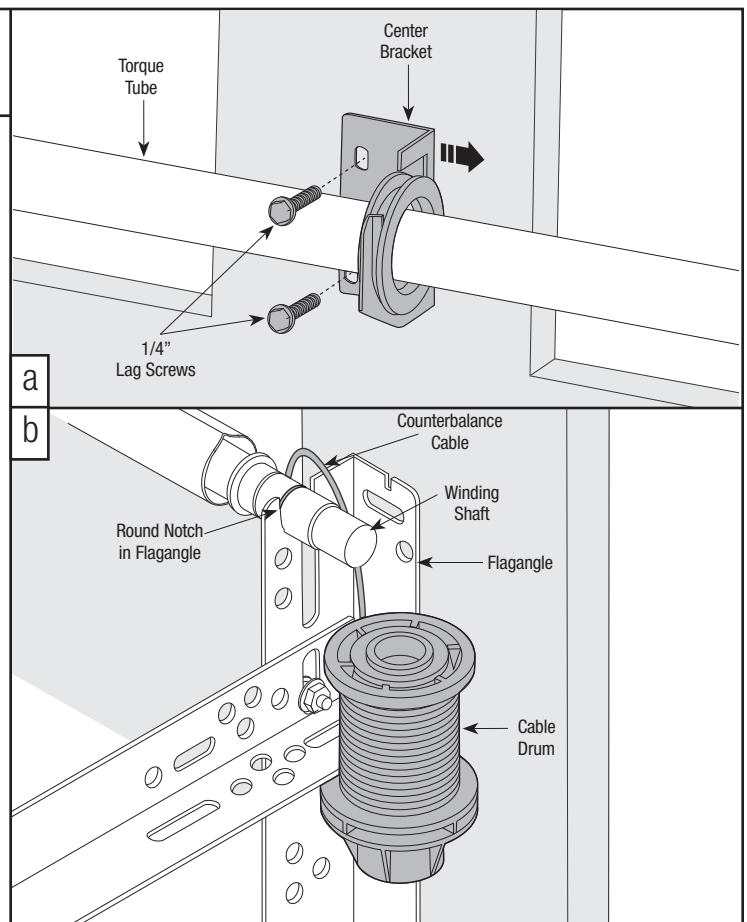

R5

9100 Top Bracket Re-Install (If Necessary)

Tools Needed:
 Power Drill
 7/16" Socket Driver
 Step Ladder

If installing an iDrive® opener on an installed 9100 door, the top bracket and roller location will have to be adjusted for the opener to work properly.

Loosen the (2) 1/4"-20 nuts from the top bracket slide.

Remove the (4) 1/4"-14 x 5/8" self-tapping screws from the top bracket.

Raise the top bracket to align the bottom slots with the second set of holes in the end cap.

Re-attach top bracket to the end cap with the (4) 1/4"-14 x 5/8" self-tapping screws.

Re-align the top roller in the horizontal track by moving the top bracket slide out to force the door section against the weather seal.

Tighten (2) 1/4"-20 Nuts.

Repeat for the opposite side.

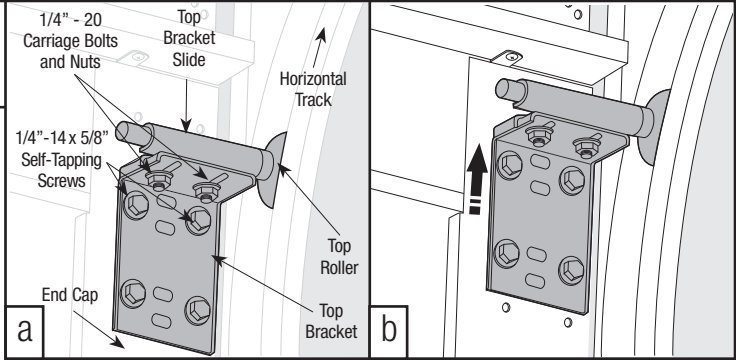

NOTE: The 9100 doors have a painted steel face, foam insulation and white paper backing. If your door does not match this description you may skip this step.

CAUTION: TO AVOID THE TOP PANEL FROM FALLING, COMPLETE RE-INSTALLATION ON ONE SIDE BEFORE BEGINNING THE OTHER.

R6

8000/8100/8200 Track Vertical Track Height Adjustment (If Required)

Tools Needed:
 Power Drill
 7/16" Socket Drive
 Pencil
 Tape Measure
 Step Ladder

NOTE: The door must be in the fully closed position.

If installing an iDrive® opener on an 8000/8100/8200 door, the top roller location and track height will have to be modified for the opener to work properly. Perform the following steps:

NOTE: The bottom edge of the track needs to be spaced 1" above the floor. If the track is already spaced off the floor 1", skip this step.

Fasten a nail in the door jamb, between the door and the track at the ends of each section. Bend the nail over each section to hold them in place.

Remove the lag screws from the flagangle and each jamb bracket. Using a 7/16" socket driver, loosen the flange nut on the Top bracket slide. Place a mark 1" up from one of the tops of one of the jamb brackets. Raise the track up and align the jamb bracket with this line. With the track relocated, re-attach the flagangle, end bracket, and jamb brackets to the header and/or door jamb. Make certain to maintain spacing between edge of door and vertical track.

NOTE: Pilot drill all lag screw locations.

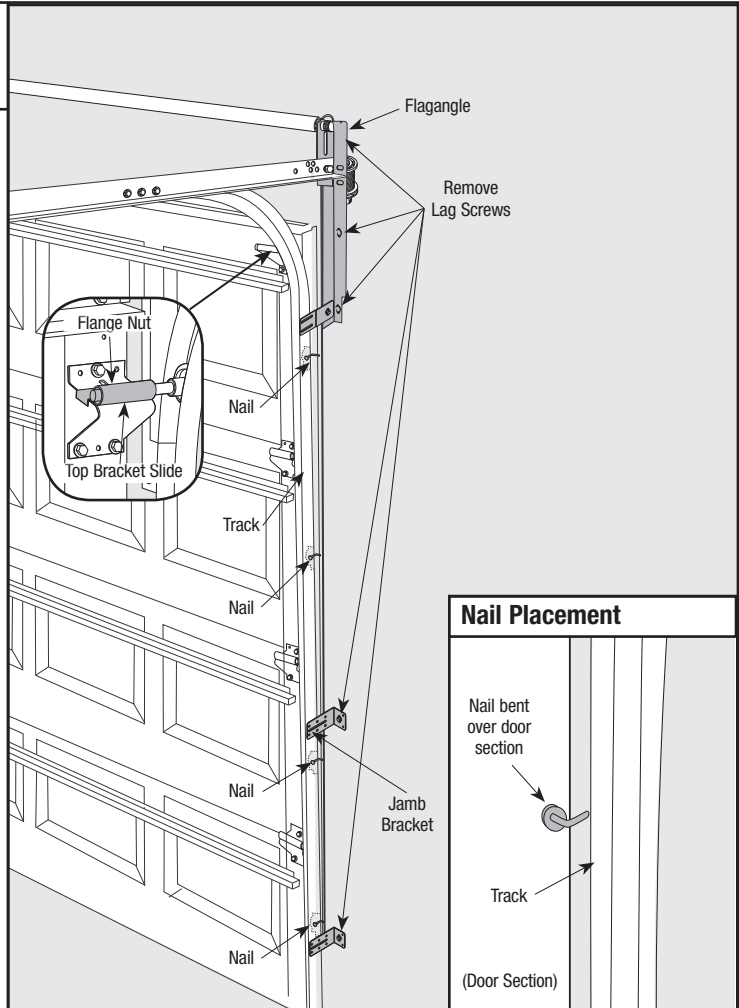

R7

8000/8100/8200 Track Horizontal Track Height Adjustment (If Required)

Tools Needed:

Level
1/2" Wrench
Step Ladder

⚠ WARNING

FAILURE TO RE-ATTACH HORIZONTAL TRACKS TO THE SUPPORT BEFORE OPENING DOOR CAN CAUSE DOOR TO FALL FROM OVERHEAD POSITION, POSSIBLY CAUSING SEVERE OR FATAL INJURY.

NOTE: Door must be in the fully closed position.

If the vertical track was raised then the horizontal track will need to be adjusted.

Remove bolt securing back of horizontal track to the perforated angle and reposition horizontal track UP 1" (25mm) from it's original position.

Re-attach the horizontal track to the perforated angle with the same bolt and nut.

Assemble bolt and nut from the direction shown so bolt will extend inside of track.

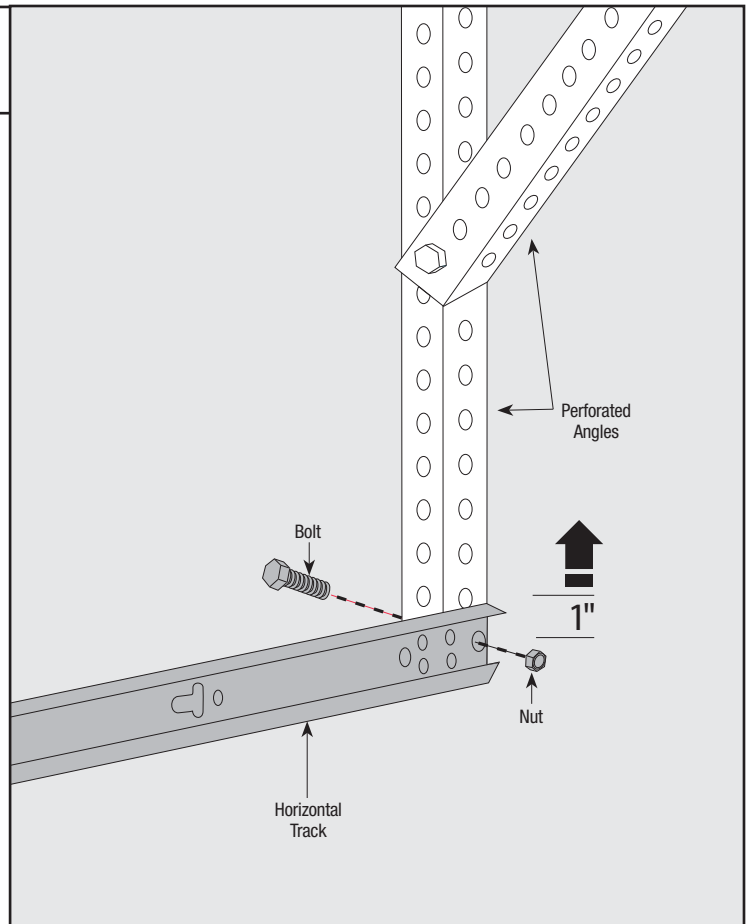

R8

8000/8100/8200 Track Top Roller Adjustment (If Necessary)

Tools Needed:

Power Drill
7/16" Socket
Driver
Step Ladder

Remove the (3) self-tapping screws from the top bracket.

Align the top hole of the top bracket with the #2 hole in the end cap and re-attach the top bracket to the end cap with the same three self-tapping screws. It may be necessary to relocate the top strut (if installed) to correctly place the top bracket in its new location.

Re-align the top roller in the track by moving top bracket slide out until door section is straight up and down. Tighten the flange nut.

Repeat for opposite side.

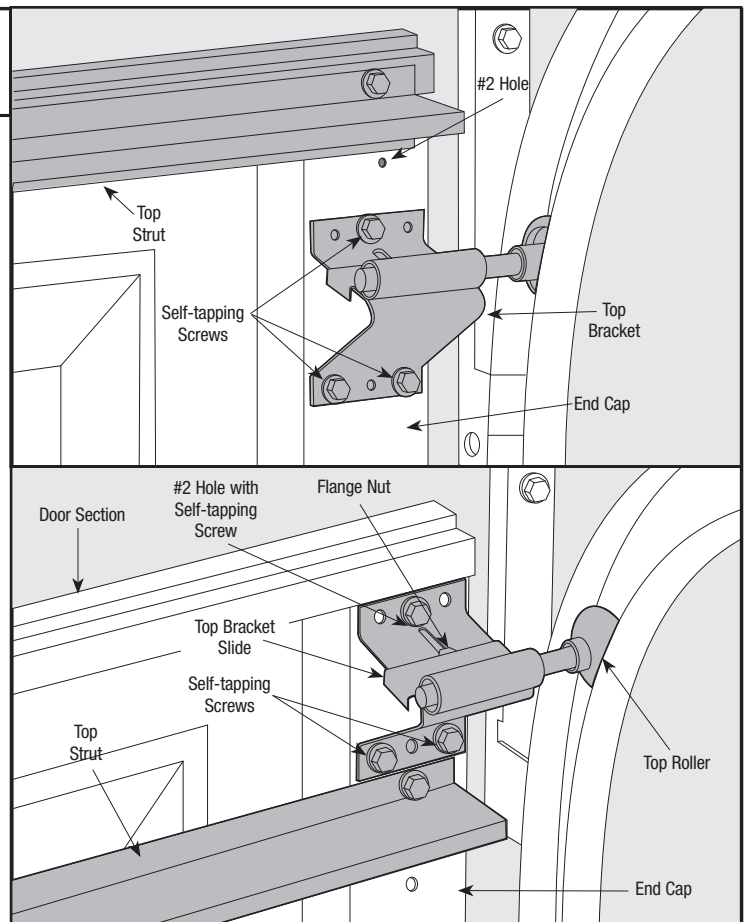

1

iDrive® for Torquemaster® Installation Assembling Opener

Tools Needed:
None

IMPORTANT! RIGHT AND LEFT HAND IS ALWAYS DETERMINED FROM INSIDE THE GARAGE LOOKING OUT.

NOTE: Older versions of the torque tube have a label applied on the right side that the opener will not slide over. Check the location of the label on the torque tube. If your torque tube has the label located on the right side, document the information on the label, then remove it completely using an adhesive remover or mineral spirits. If your torque tube has the label located on the left side, proceed with the following instructions.

Lay the torque tube on the floor (inside garage) in front of the door with the labeled end to the left.

Look into the opener's left side to ensure the left hand bearing and the internal (black) sleeve are aligned with the torque tube profile.

IMPORTANT! HOLD OPENER BY THE MAIN BODY. DO NOT HOLD BY THE MOTOR.

Once aligned, slide the opener onto the right hand end of the torque tube. As the right end of the torque tube enters the internal (black) sleeve, rotate the opener back and forth slightly to help aid alignment.

Continue sliding the opener onto the torque tube. Align the right hand bearing with the torque tube and slide the opener completely onto the torque tube until the torque tube exits the opener right hand bearing.

NOTE: Do not force the opener onto the torque tube if misalignment occurs.

Continue sliding the opener to the center of the torque tube.

Plug the motor power cord into the opener.

After completing this step, continue with Step 2 on page 8 for Torquemaster® Plus; Step 2 on page 10 for Torquemaster®.

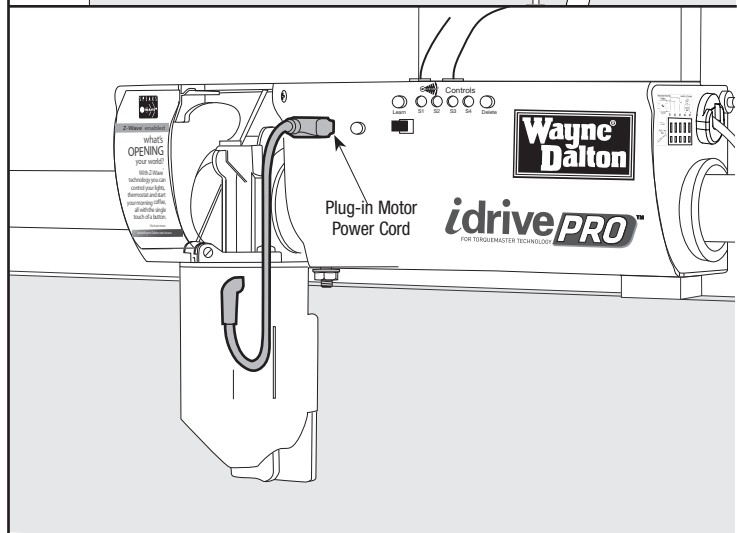
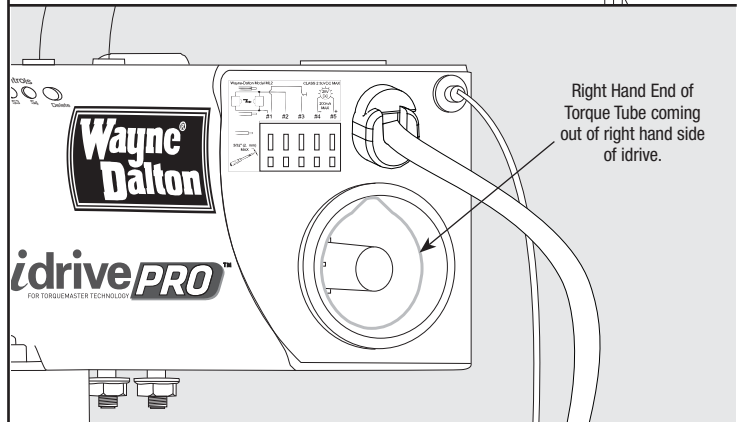
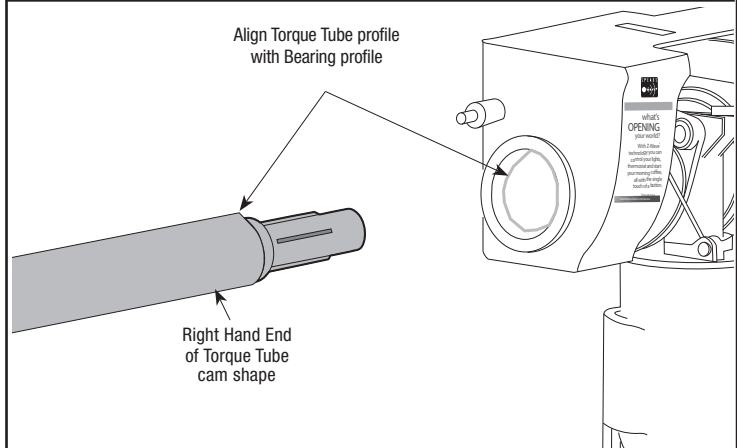
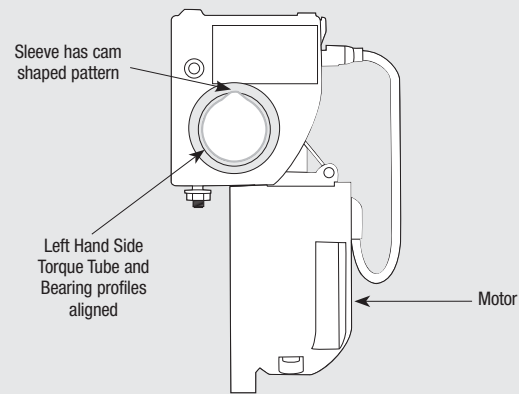

2

Cable Drums

Tools Needed:
Tape Measure
Step Ladder

NOTE: If you have a Torquemaster® counterbalance, skip this step and continue with Step 2 on page 10. If you have a Torquemaster® Plus counterbalance system, complete Steps 2-3 on pages 8 and 9.

IMPORTANT! RIGHT AND LEFT HAND IS ALWAYS DETERMINED FROM INSIDE THE GARAGE LOOKING OUT.

Shake the Torquemaster® spring tube assembly gently to extend the winding shafts out about 5" on each side. For single spring applications, there will be no left hand spring in the Torquemaster® spring tube assembly.

Lift the Torquemaster® spring tube assembly and rest it on the top of the flagangles.

NOTE: Cable drums are marked right and left hand. Cable drums and Torquemaster® spring tube assembly are cam shaped to fit together only one way.

Pre-wrap the Torquemaster® Plus cable drum with the counter balance cable 1-1/2 wraps (see illustrations).

To install the cable drum, slide the correct cable drum over the winding shaft until the cable drum seats against the Torquemaster® spring tube assembly.

The winding shaft must extend past the cable drum far enough to expose the splines and the groove. Align the winding shaft groove with the round notch in the flagangle.

For double spring applications, repeat for opposite side.

For single spring applications, pre-wrap the left hand Torquemaster® Plus cable drum with counter balance cable 1-1/2 wraps and insert the loose winding shaft into the cable drum prior to sliding the cable drum over the Torquemaster® spring tube assembly.

NOTE: On single spring applications, take care in handling the loose winding shaft (left side) so that it does not slide back into the Torquemaster® spring tube assembly.

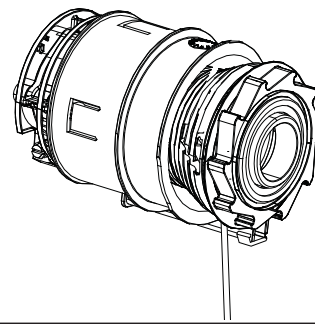

Drums come with drum wraps pre-installed on them.

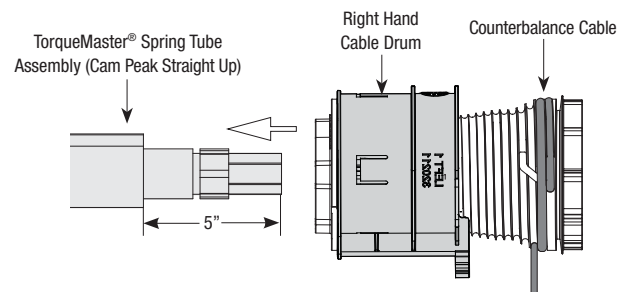

1-1/2 Wrap

(Right hand cable drum shown, left hand cable drum is symmetrically opposite)

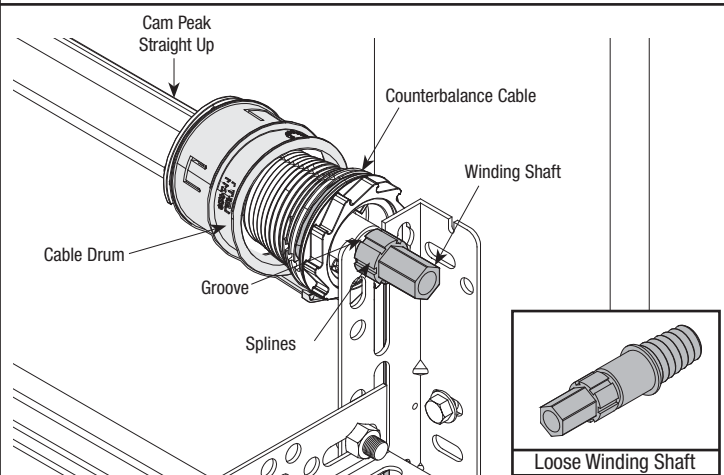
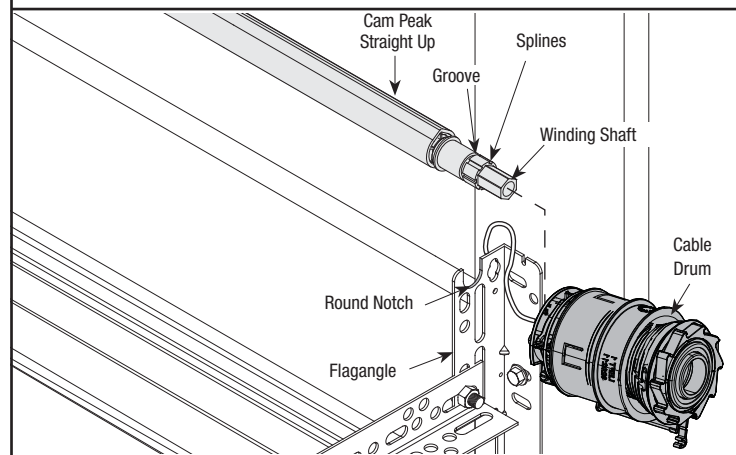

3

End Brackets

Tools Needed:

Power Drill

7/16" Socket Driver

1/2" Wrench

Step Ladder

IMPORTANT! WARNING TAGS MUST BE SECURELY ATTACHED TO BOTH END BRACKETS.

End brackets are right and left hand. You can identify the right hand end bracket by the disconnect cable guide hole in the top of the bracket.

Beginning with either side, slide the end bracket onto the winding shaft so that the grooves in the ratchet wheel fit onto the winding shaft splines.

Secure end bracket to the flag angle using (1) 5/16"-18 x 3/4" carriage bolt, 3/4" washer and hex nut; then secure to the jamb with 5/16" x 1-5/8" hex head lag screw.

Repeat for other end bracket.

NOTE: No ratchet wheel is required on the left hand side for single spring applications. Only an end bracket is needed.

After completing this step, continue with Step 4 on page 12.

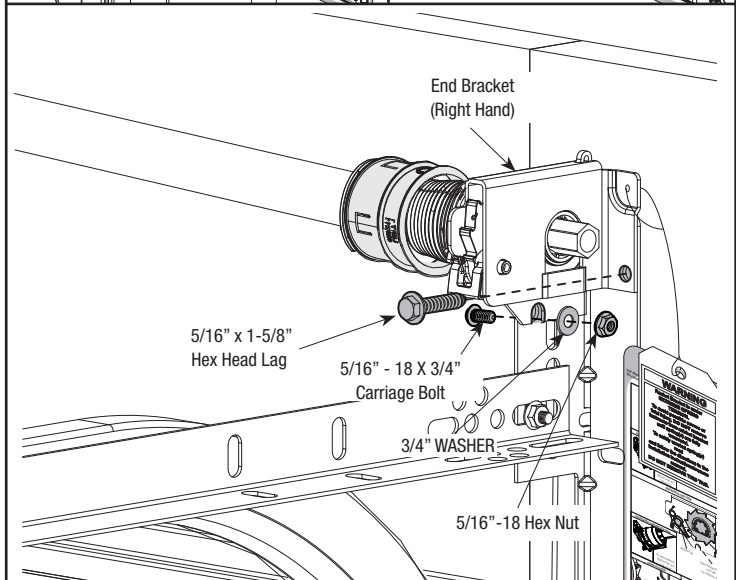
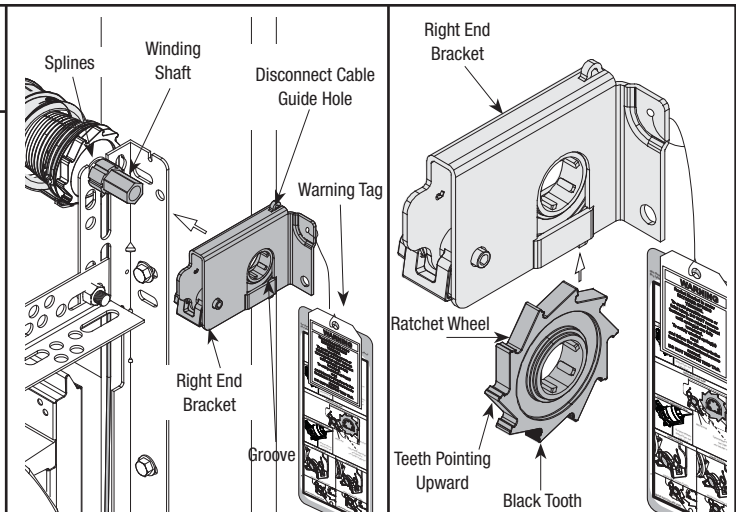

2

Cable Drum/ Drive Gear Installation

Tools Needed:
Step Ladder

NOTE: If you just installed the Torquemaster® Plus counterbalance, continue with Step 4 on page 12. If you have the Torquemaster® counterbalance system, complete Steps 2-3 on pages 10 and 11.

Shake the torque tube gently to extend the winding shafts out about 5" on each side. For single spring applications, there will be no left hand spring in the torque tube.

Lift the torque tube and rest it on the top of the flagangles. Orient torque tube so that back of opener is flat against header/ mounting surface.

NOTE: Cable drums and torque tube are cam shaped to fit together only one way.

Pre-wrap the Torquemaster® cable drum with the counter balance cable 1/2 wrap (see illustrations).

To install the cable drum, slide the cable drum over the winding shaft until the cable drum seats against the torque tube. The winding shaft must extend past the cable drum far enough to expose the splines and the groove.

Align the winding shaft groove with the round notch in the flagangle.

For double spring applications, repeat for opposite side.

For single spring applications, pre-wrap the left hand Torquemaster® cable drum with counter balance cable 1/2 wrap and insert loose winding shaft into the cable drum prior to sliding the cable drum over the torque tube.

NOTE: On single spring applications, take care in handling the loose winding shaft (left side) so that it does not slide back into the torque tube.

Beginning with the right hand side, lubricate entire circumference of the drive gear with lubricating oil. Slide the drive gear onto the winding shaft splines until it touches the flagangle.

NOTE: On single spring applications, no drive gear is required on the left side.

NOTE: If additional lubricating oil is required "Dura-Lube Engine Oil Treatment" is recommended.

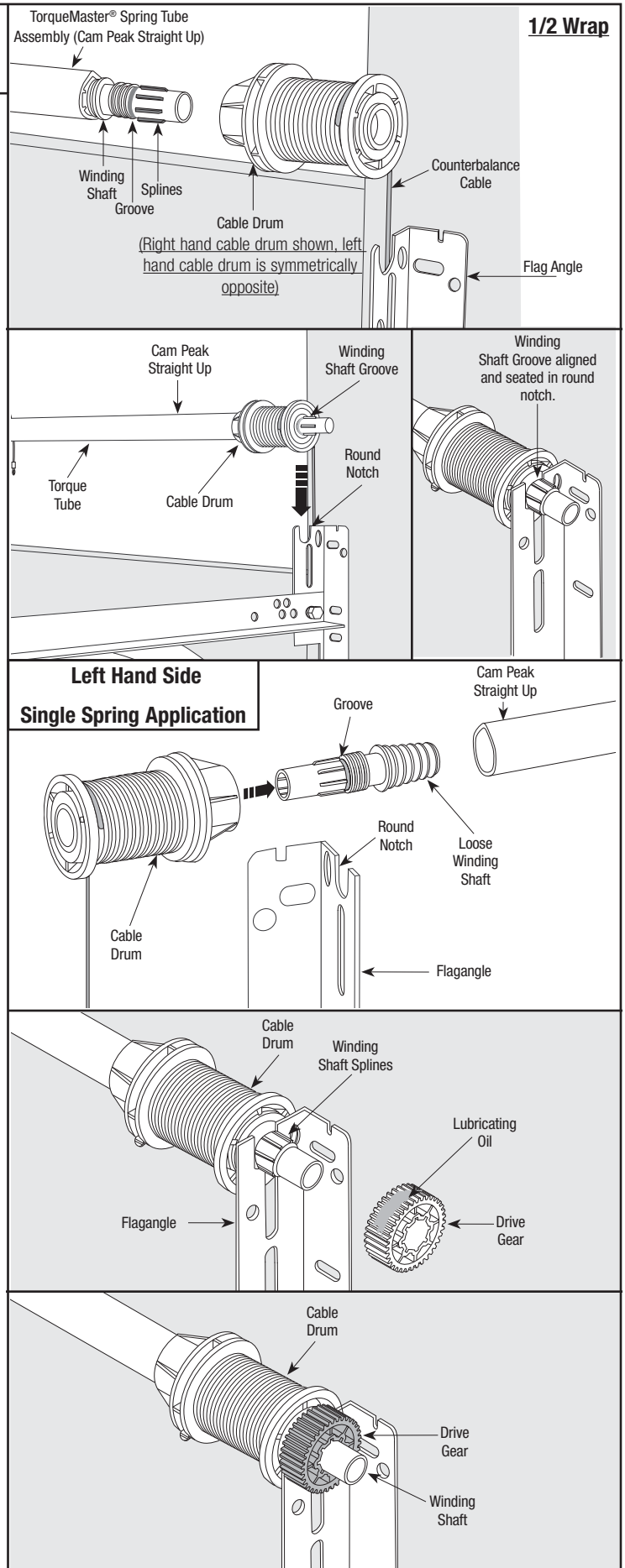

3

End Bracket Installation

Tools Needed:

Power Drill
3/32" Drill Bit
7/16"
Socket Driver
Phillips Head
Screwdriver
Step Ladder

IMPORTANT! WARNING TAGS MUST BE SECURELY ATTACHED TO BOTH END BRACKETS.

Slide the right hand end bracket over the drive gear. Replace #10 phillips head screw that was removed in Step R3. Secure end bracket and the flagangle to the jamb using (2) 5/16" x 1-5/8" lag screws.

NOTE: Older end brackets may not have a hole needed for the opener's emergency disconnect cable. If the right hand end bracket does not have a hole for the disconnect cable, drill a 3/32" (3mm) hole as shown prior to installing the end bracket.

Install the right side counter gear, with the missing tooth toward the outside and away from the end bracket. Press the counter gear onto the end bracket until snaps engage.

Select the right hand counter cover and align the hex of the counter cam with the end of the winding shaft. Also, align the "0" on the counter cover with the raised rib on the end bracket. Press the counter cover against the counter gear until it locks into place.

Repeat for left hand side for double spring applications.

NOTE: No drive gear, counter gear or counter cover is required on left hand side for single spring applications. Only an end bracket is needed.

IMPORTANT! AT THIS TIME DO NOT WIND COUNTERBALANCE SPRINGS!

After completing this step, continue with Step 4 on page 12.

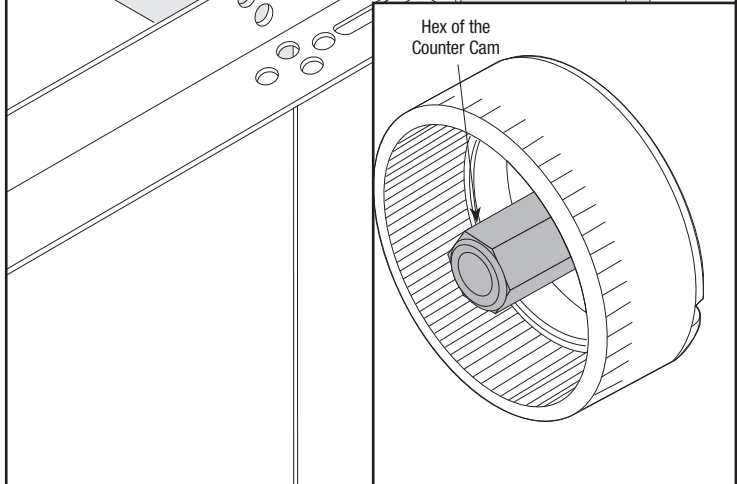
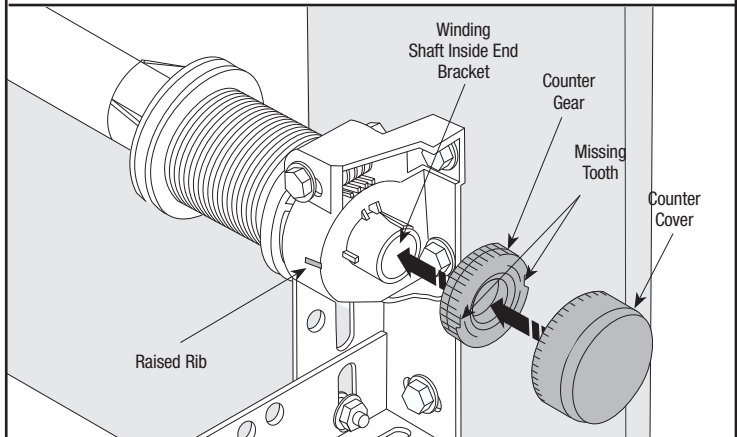
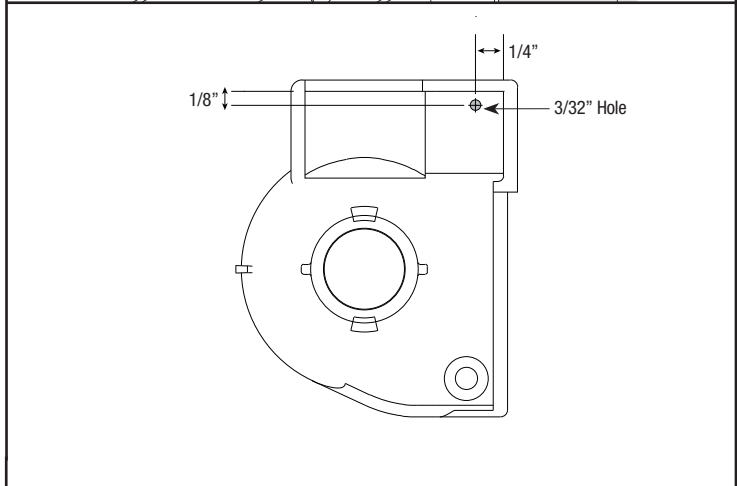
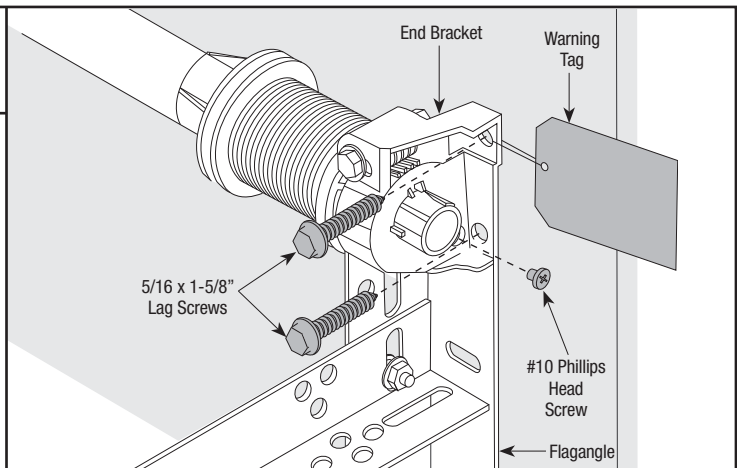

4

Positioning Support Bracket

Tools Needed:

- Power Drill
- 1/8" Drill Bit
- 7/16" Socket Driver
- Tape Measure
- Step Ladder

NOTE: *idrive*® must be installed on a solid mounting surface.

Locate the mounting surface. The mounting surface is a vertical board running directly above the center of the door. Remove (2) 1/4"-20 flange nuts from bottom of opener.

NOTE: Do not discard flange nuts.

Place the support bracket underneath opener, to the right side of motor, centered on mounting surface.

Using a tape measure, maintain equal measurements between torque tube and top of door at both ends and in center to ensure torque tube is level. Once torque tube is level, with *idrive* resting on support bracket, drill 1/8" pilot holes for the lag screws.

Now secure support bracket to the mounting surface with (2) 1/4" x 1-1/2" lag screws.

NOTE: If wood mounting surface is covered with dry wall, use 1/4" x 2" lag screws.

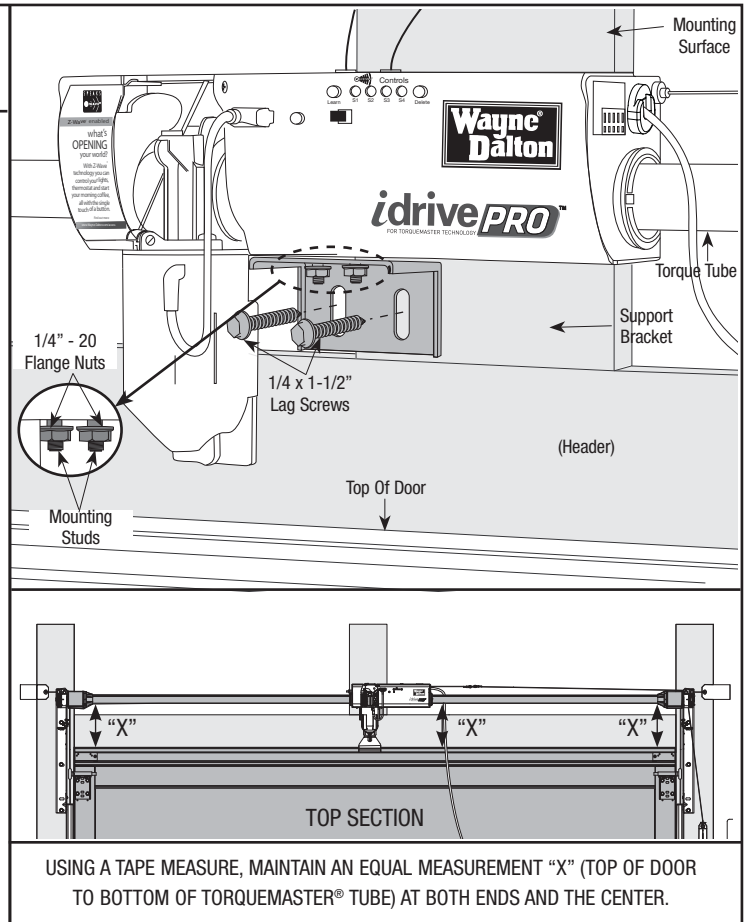

5

Attaching Opener To Support Bracket

Tools Needed:

- Step Ladder

Lift and slide the opener over the support bracket, aligning the mounting studs with the bracket slots. Loosely fasten to mounting studs with the (2) 1/4"-20 flange nuts.

Alternately, the disconnect cable can be pulled to allow motor to pivot up. This will enable assembly of the support bracket to the opener first, followed by leveling of the torque tube and then attachment of support bracket to mounting surface.

NOTE: Do not tighten 1/4"-20 flange nuts to opener studs at this time.

Remove the orange label holding the antenna wire. Straighten antenna wire and angle it 45 degrees to the right.

NOTE: Do not coil the antenna wire. This will reduce the radio signal range.

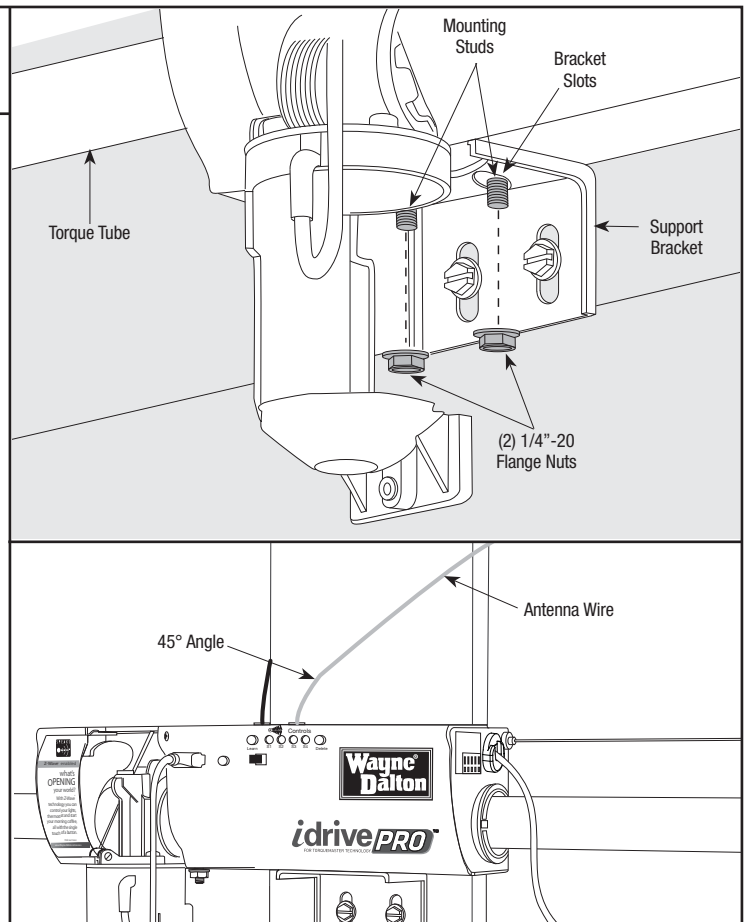

6

Attaching Disconnect Cable

Tools Needed:
Step Ladder
Pliers

Attach the loose disconnect cable (located in opener hardware bag) to the opener with the "S" hook. Close both ends of the "S" hook with pliers, to lock assembly together with pliers.

Thread the disconnect cable (behind the counterbalance cable) through the hole in the right hand end bracket, and remove all slack between opener and right end bracket.

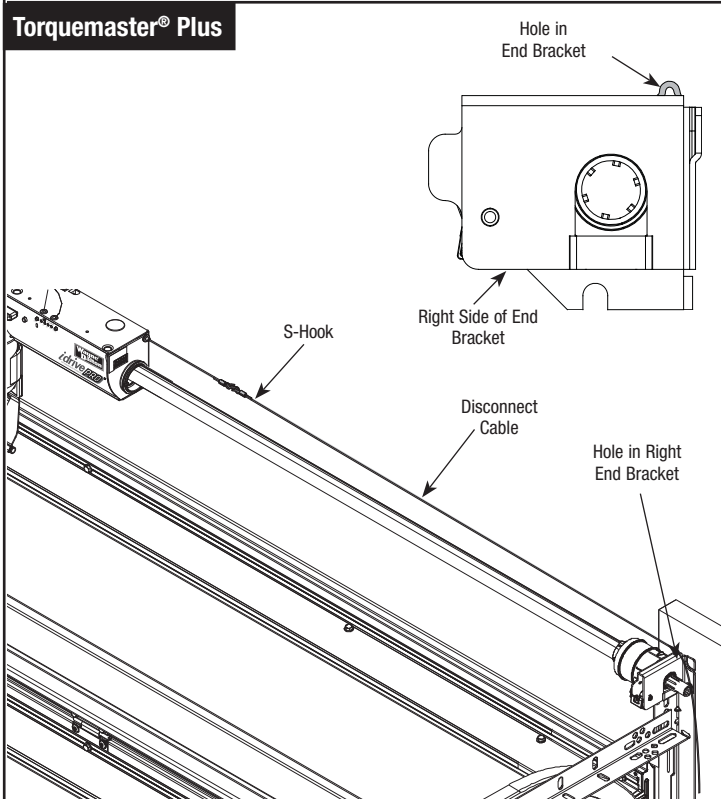
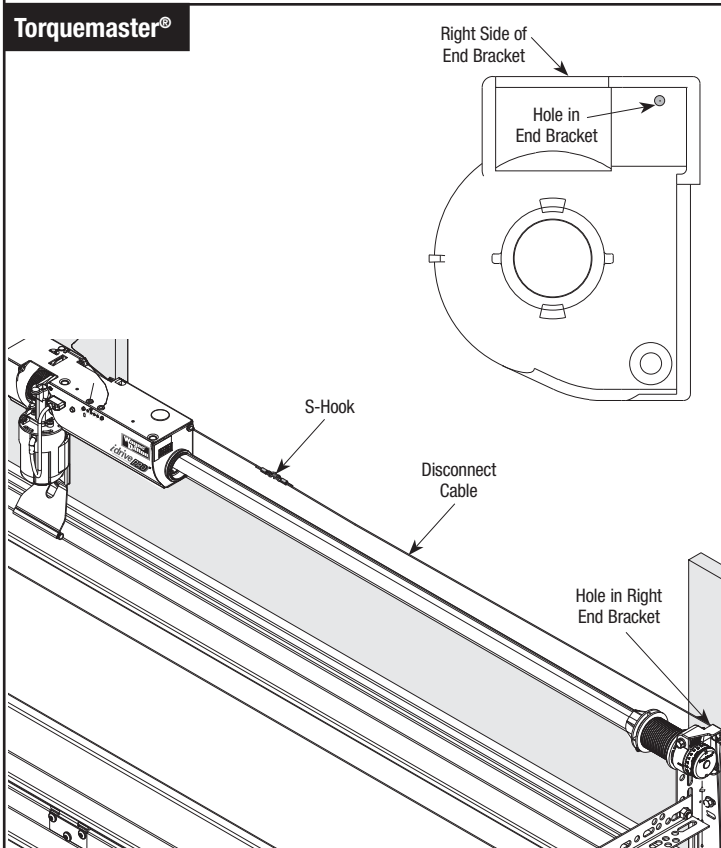
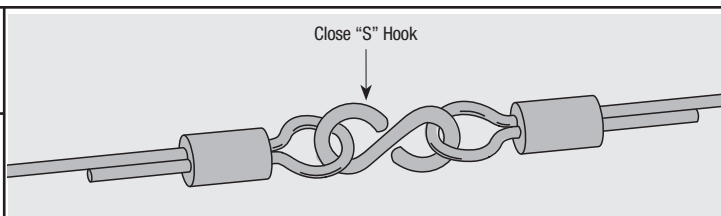

7

Mounting Disconnect Handle Bracket

Tools Needed:

- Pencil
- Tape Measure
- Power Drill
- 1/8" Drill Bit
- 7/16" Socket Driver

Mark a location on the right jamb, 6 feet above the floor to mount the disconnect handle bracket.

Pilot drill lag screw location using 1/8" drill bit.

Align top of the bracket with the mark.
Fasten bracket to the jamb with (2) 1/4" x 1-1/2" lag screws.

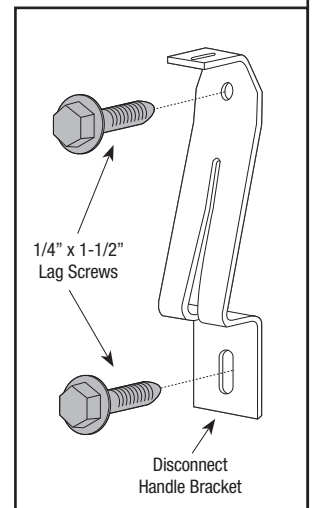
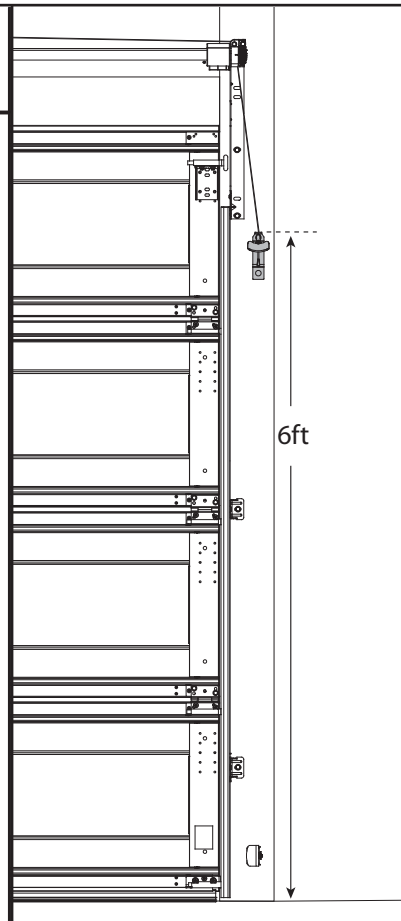

8

Attaching Disconnect Handle

Tools Needed:

- Phillips Head Screwdriver
- Wire Cutters
- Flat Blade Screwdriver

NOTE: The motor must be in the fully down position before setting handle position on cable. Bring motor to the down position by pulling the disconnect cable while pushing the motor down. Insure opener disconnect teeth are engaged before installing disconnect handle. If motor is not fully down when teeth are engaged, turn motor shaft with screwdriver at back of motor counter clockwise until motor is fully down.

NOTE: Do not use power drill to assemble set screw to handle.

Start the #6-20 x 1/2" screw into the disconnect handle. Thread the disconnect cable through the top of the disconnect handle bracket and then the disconnect handle.

Locate the disconnect handle in full upper position of disconnect handle bracket.

Remove all disconnect cable slack between the opener and the top of the disconnect handle bracket. Tighten #6-20 x 1/2" screw into the disconnect handle until snug, and then tighten screw an additional 1 to 1-1/2 turns to secure disconnect cable to the disconnect handle. Trim off excess cable from bottom of the disconnect handle.

CAUTION: PULL CABLE ONLY TAUT ENOUGH TO REMOVE THE CABLE SLACK. PULLING THE CABLE MORE COULD CAUSE OPENER TO DISCONNECT FROM THE TORQUE TUBE AND CAUSE FAILURE OF THE DISCONNECT.

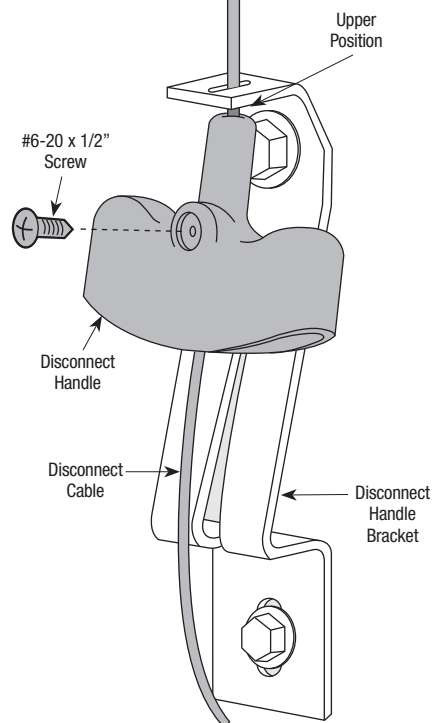

9

Disconnect Handle Usage

Tools Needed:

None

Apply emergency disconnect label next to the mounted bracket. Use mechanical fasteners if adhesive will not adhere.

Using the emergency disconnect, pull down on disconnect handle and place it in the manual door operated position (use disconnect label for reference). Motor will be rotated 90° from its packaged position.

If motor does not pivot 90°, see troubleshooting section in this manual.

Manual operated position

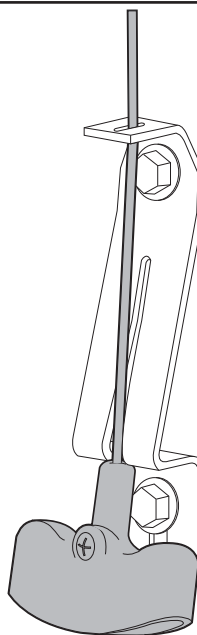

Motor operated position

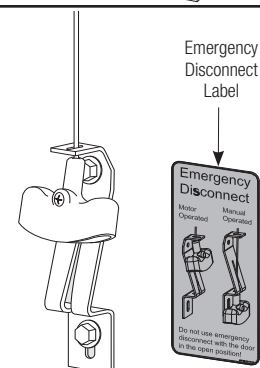
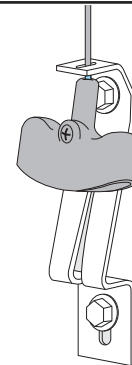

10

Cable Adjustments

Tools Needed:

Pliers/Wire
Cutter

Flat Tip
Screwdriver

Locking Pliers

Step Ladder

Starting on the right hand side, rotate the cable drum until the set screw faces directly away from the header. Torque tube cam peak should be pointing straight up.

NOTE: Illustrations show the right hand cable drum, left hand cable drum is symmetrically opposite.

NOTE: Cable tension is set during the initial door installation. If there is slack between the counterbalance cable and the cable drum or unequal tension between the right and left hand counterbalance cables, the counterbalance cables will have to be readjusted. If there is no slack and cable tension is equal, proceed to Step 11. Loosen the set screw no more than 1/2 turn. Using locking pliers, pull on the end of the cable to remove all cable slack. Check to ensure the cable is aligned and seated in the appropriate groove(s) of the cable drum. Snug the set screw, and then tighten an additional 1-1/2 turns. Left side will be adjusted in Step 12.

IMPORTANT! ENSURE THE CABLE IS ALIGNED AND SEATED IN THE APPROPRIATE GROOVE(S) OF THE CABLE DRUM PRIOR TO WINDING SPRINGS.

Measure approximately 6" of cable, cut off excess cable, tuck end into cable drum (Torquemaster®) or insert end in hole of cable drum (Torquemaster® Plus).

Torquemaster®

1/2 Wrap

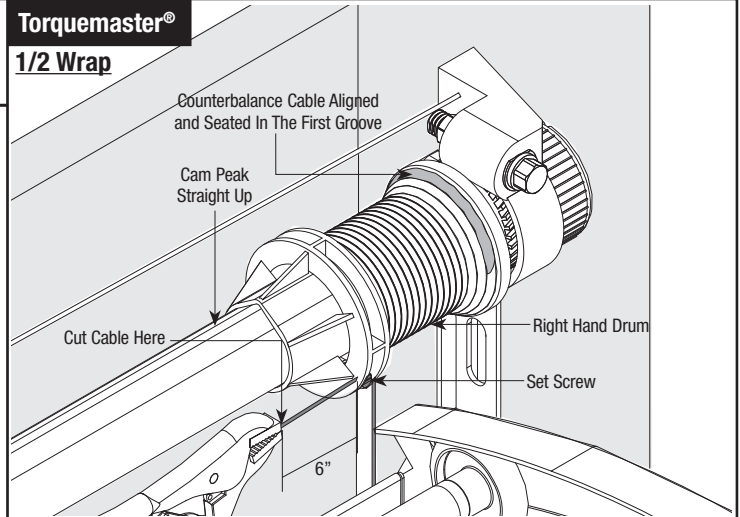

Torquemaster® Plus

1-1/2 Wrap

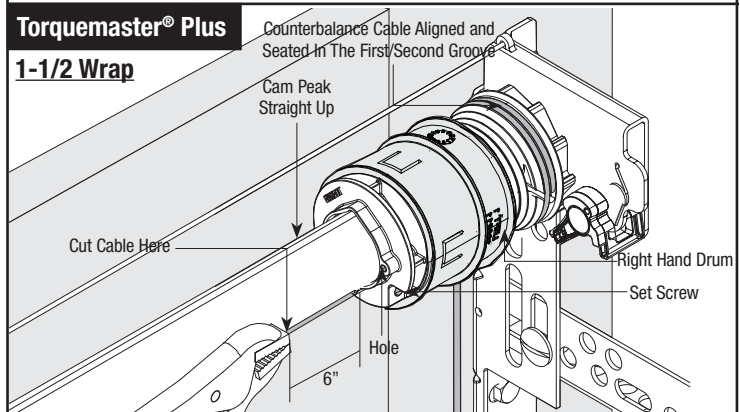

11

Securing Door for Spring Winding

Tools Needed:
(2) Vice Clamps

Place vice clamps onto both vertical tracks just above the third roller. This is to prevent the garage door from raising while winding the springs.

WARNING

FAILURE TO CLAMP TRACK CAN ALLOW DOOR TO RAISE UNEXPECTEDLY, RESULTING IN SEVERE OR FATAL INJURY.

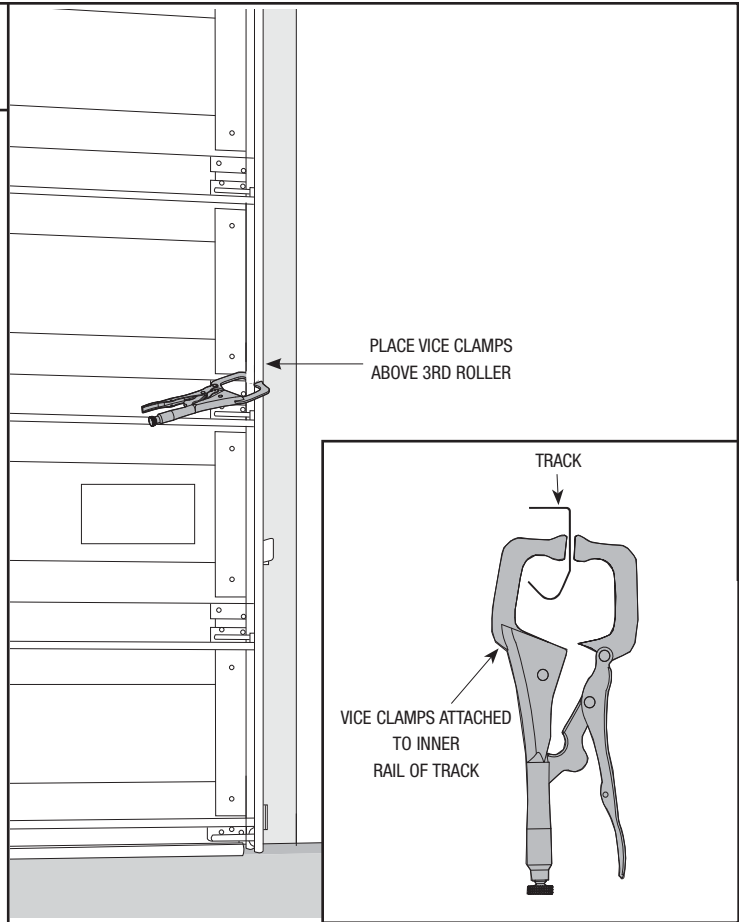

Winding Spring(s)

Tools Needed:
5/8" Socket
Ratchet Wrench
3" Extension
Step Ladder

NOTE: If you have a Torquemaster® counterbalance, skip this step and continue with Step 12 on page 20.

NOTE: It is recommended that leather gloves be worn while winding the TorqueMaster® Plus springs.

⚠ WARNING

FAILURE TO WEAR GLOVES MAY CAUSE INJURY TO HANDS.

See chart on page 19 for proper spring tension setting.

Double check to ensure the counterbalance cable is aligned in the first and second groove of the cable drum, as shown in Step 10.

There are two methods for counting the spring turns as you wind. One method is to identify the black tooth on the ratchet wheel inside of the end bracket. When the wheel makes one revolution and the tooth returns to its starting point, one turn has been made. The other method is to make a mark on the winding shaft (or socket) and end bracket, and count your turns in this manner.

IMPORTANT! PAWL KNOB MUST BE IN UPPER POSITION TO ADD/ REMOVE SPRING TURNS. AFTER ADDING / REMOVING SPRING TURNS, PAWL KNOB MUST BE PLACED BACK IN LOWER POSITION.

Beginning with the right side, place a mark on winding shaft (or socket) and end bracket. Turn pawl knob on the end bracket to the upper position. Using a ratchet with a 5/8" socket, wind the spring by rotating the winding shaft counter clockwise, while watching the mark on the winding shaft.

NOTE: A 3" extension is also recommended for added clearance from the horizontal angle.

After 2-3 turns, remove the ratchet and adjust the cable on the left side. Ensure the cable is in the first and second groove of the cable drums as shown in Step 10 and clear of any obstructions.

NOTE: Single spring applications require no spring winding on left hand side, but need cable tension adjusted.

IMPORTANT! ENSURE COUNTERBALANCE CABLE TENSION IS EQUAL FOR BOTH SIDES PRIOR TO FULLY WINDING SPRING(S) TO APPROPRIATE NUMBER OF TURNS. IF CABLE TENSION IS UNEQUAL, REFER TO STEP 10.

See the **Spring Turn** chart.

For **SINGLE SPRING** applications, return to the right hand side and continue winding the spring to the required number of turns for your door or the number record during the Pre-Installation Inspection on page II. Place pawl knob in lower position.

For **DOUBLE SPRING** applications, place a mark on the left hand winding shaft and end bracket. Place the ratchet with 5/8" socket onto the left hand winding shaft end.

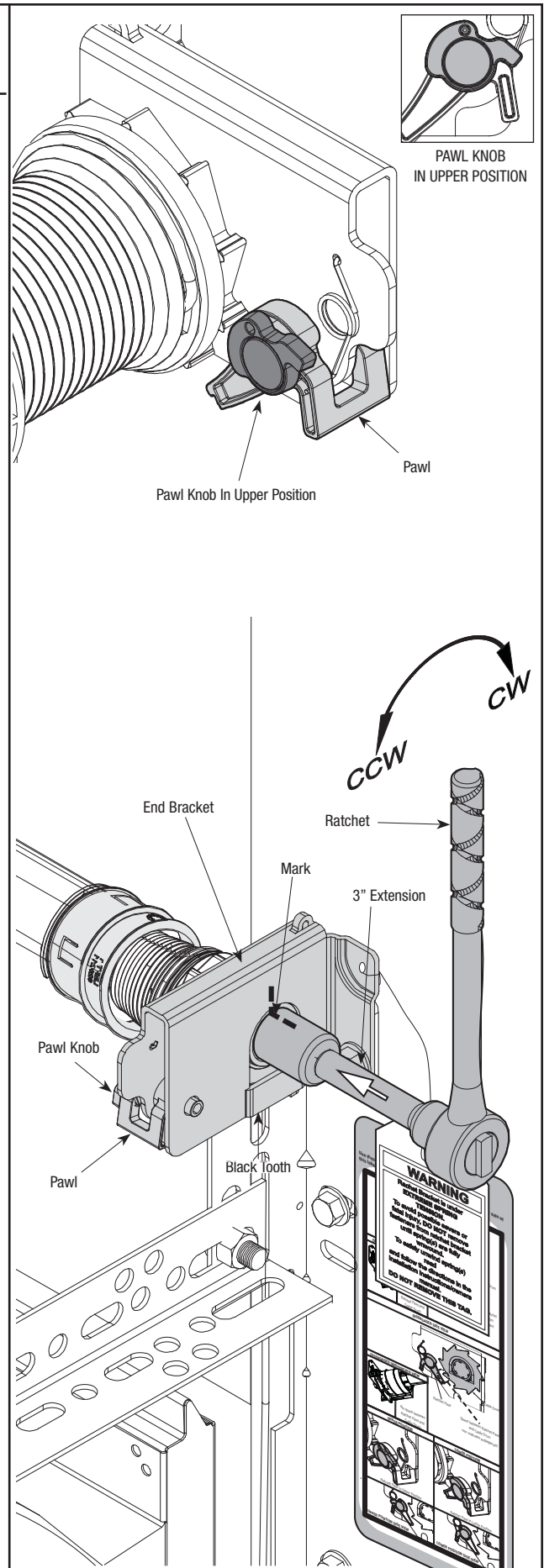

Winding Spring(s) (Continued)

Tools Needed:

To wind the spring, rotate the winding shaft clockwise, while watching the mark on the winding shaft (or socket). Rotate the winding shaft to the required number of turns for your door or the number recorded during the Pre-Installation Inspection on page II. Place ratchet pawl in lower position. Then return to the right hand side and wind the right hand spring to the required number of turns or the number recorded during the Pre-Installation Inspection on page II. Place ratchet pawl in lower position.

IMPORTANT! DO NOT OVERWIND SPRINGS.

NOTE: Since total turns to balance door can deviate from spring turn chart values by $\pm 1/2$ turns, adjustments to the recommended number of spring turns may be required AFTER rear hangers assembly is completed.

IMPORTANT! CAUTIOUSLY REMOVE VICE CLAMPS FROM VERTICAL TRACKS. ADJUSTMENTS TO THE RECOMMENDED NUMBER OF TURNS MAY BE REQUIRED. IF DOOR RAISES OFF THE FLOOR UNDER SPRING TENSION ALONE, THEN REDUCE SPRING TENSION UNTIL DOOR RESTS ON THE FLOOR. IF THE DOOR IS HARD TO RAISE OR DRIFTS DOWN ON ITS OWN, THEN ADD SPRING TENSION. AN UNBALANCED DOOR CAN CAUSE IDRIVE® OPERATION PROBLEMS.

IMPORTANT! IF YOU ARE INSTALLING THE IDRIVE® OPENER ON A NEW GARAGE DOOR, REAR SUPPORTS WILL NEED TO BE FABRICATED/ INSTALLED TO SUPPORT THE HORIZONTAL TRACKS. REAR SUPPORTS ARE CONSTRUCTED USING PERFORATED ANGLES, HEX HEAD BOLTS/NUTS AND THEN THE MUST BE SECURELY ATTACHED TO SOUND FRAMING MEMBERS WITH LAG SCREWS. FOR DETAILED INFORMATION ON CONSTRUCTING/ SUPPORTING THE REAR SUPPORTS, REFER TO YOUR DOORS INSTALLATION INSTRUCTIONS AND OWNER'S MANUAL.

RECOMMENDED SPRING TURNS

Door Height	Spring Turns
6'-0"	14
6'-3"	14-1/2
6'-5"	15
6'-6"	15
6'-8"	15-1/2
6'-9"	15-1/2
7'-0"	16
7'-3"	16-1/2
7'-6"	17
7'-9"	17-1/2
8'-0"	18

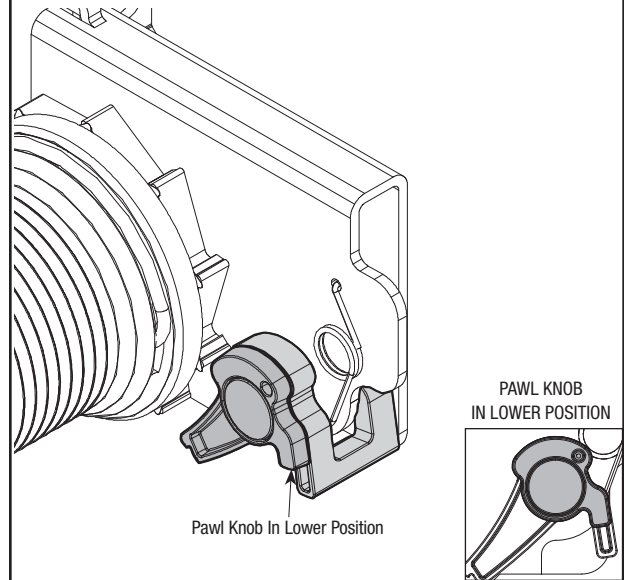

13

Drum Wrap Installation

Tools Needed:
Step Ladder

Un-snap the drum wrap hinged latch and rotate down.

IMPORTANT: Pull the counterbalance cable away from the header to clear the latch. Simultaneously slide the drum wrap against the last rib of the drum until the 3 tabs engage the third rib

Re-engage the hinged latch by rotating upward until a distinct snap is felt.

Confirm the catch is fully engaged by lightly tugging on it.

Repeat for the left hand side.

After completing this Step, continue with Step 14 on page 21.

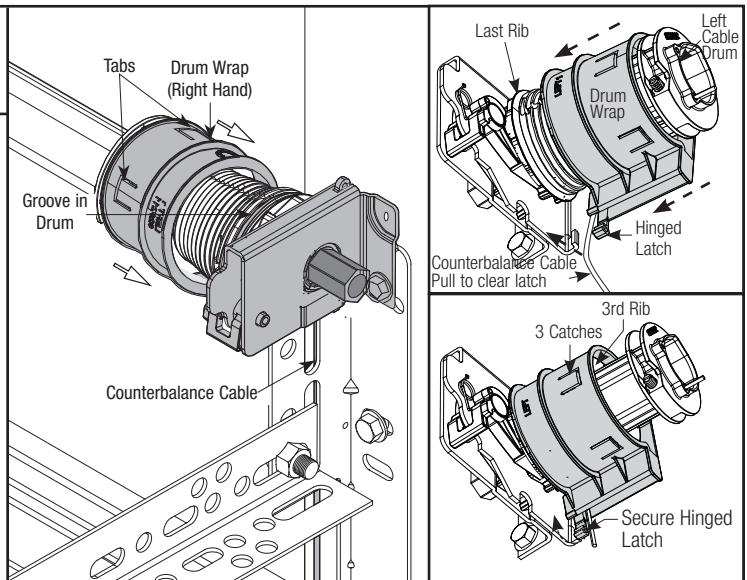

Setting Spring Tension

Tools Needed:

- Power Drill
- 7/16" Socket Driver
- 7/16" Wrench
- Step Ladder

See chart below for proper spring tension setting.

Beginning with the right hand side, ensure the counterbalance cable is in the first groove of the cable drum. **NOTE:** Apply light pressure to the canoe clip on counter while winding springs.

Using a power drill (high torque/gear reduced to 1300 RPM preferred) with a 7/16" socket driver, carefully rotate right hand winding bolt clockwise, until counter shows 2-3 turns. This will keep the counterbalance cable taut while adjusting the left hand side counterbalance cable.

Adjust left hand counterbalance cable tension (Refer to step 10).

NOTE: Single spring applications require no spring winding on left hand side, but need cable tension adjusted.

IMPORTANT! Ensure counterbalance cable tension is equal for both sides prior to fully winding spring(s) to appropriate number of turns. If cable tension is unequal, refer to Step 10.

See the **Spring Turn** chart.

For SINGLE SPRING applications, return to the right hand side and carefully rotate the winding bolt head clockwise until the counter shows the correct number of turns for your door or the number record during the Pre-Installation Inspection on page II.

For DOUBLE SPRING applications, remain on the left hand side and carefully rotate the winding bolt head clockwise until the counter shows the correct number of turns for your door or the number record during the Pre-Installation Inspection on page II. Then return to the right hand side and wind the right hand spring to the required number of turns for your door or the number recorded during the Pre-Installation inspection on page II.

IMPORTANT! DO NOT OVERWIND.

After spring is wound, hold the lock nut (in back of end bracket) stationary with a 7/16" wrench while rotating the winding bolt clockwise until snug. Tightening of the lock nut prevents spring from unwinding. Repeat for opposite side on double spring Torquemaster® systems.

IMPORTANT! CAUTIOUSLY REMOVE VICE CLAMPS FROM VERTICAL TRACKS. ADJUSTMENTS TO THE RECOMMENDED NUMBER OF TURNS MAY BE REQUIRED. IF DOOR RAISES OFF THE FLOOR UNDER SPRING TENSION ALONE, THEN REDUCE SPRING TENSION UNTIL DOOR RESTS ON THE FLOOR. IF THE DOOR IS HARD TO RAISE OR DRIFTS DOWN ON ITS OWN, THEN ADD SPRING TENSION. AN UNBALANCED DOOR CAN CAUSE IDRIVE® OPERATION PROBLEMS.

IMPORTANT! IF YOU ARE INSTALLING THE IDRIVE® OPENER ON A NEW GARAGE DOOR, REAR SUPPORTS WILL NEED TO BE FABRICATED/ INSTALLED TO SUPPORT THE HORIZONTAL TRACKS. REAR SUPPORTS ARE CONSTRUCTED USING PERFORATED ANGLES, HEX HEAD BOLTS/NUTS AND THEN THE MUST BE SECURELY ATTACHED TO SOUND FRAMING MEMBERS WITH LAG SCREWS. FOR DETAILED INFORMATION ON CONSTRUCTING/ SUPPORTING THE REAR SUPPORTS, REFER TO YOUR DOORS INSTALLATION INSTRUCTIONS AND OWNER'S MANUAL.

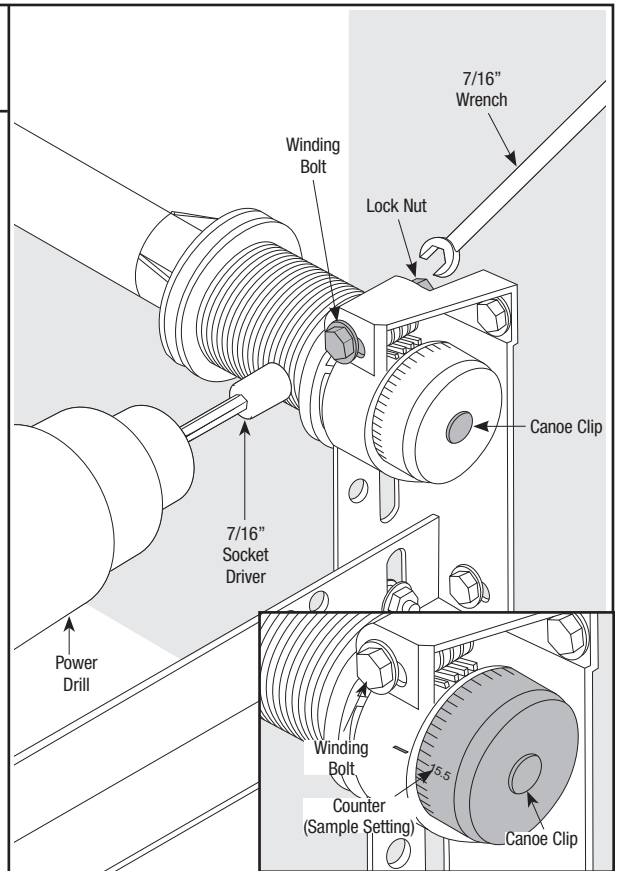

NOTE: For 7' high doors, 8', 9', 10', 16' or 18' wide with windows, the recommended number of spring turns is 15.

RECOMMENDED SPRING TURNS		
Door Height	Doors 11'-11" Wide or Less	Doors 12' Wide or Greater
6'-0"	13-1/2	14
6'-3"	14	14-1/2
6'-5"	14-1/2	15
6'-6"	14-1/2	15
6'-8"	15	15-1/2
6'-9"	15	15-1/2
7'-0"	15-1/2	16
7'-3"	16	16-1/2
7'-6"	16-1/2	17
7'-9"	17	17-1/2
8'-0"	17-1/2	18

13

Drum Wrap Installation

Tools Needed:
Step Ladder

Drum wraps (supplied with Torquemaster® counterbalance systems) are identified as right and left.

To install, place the drum wrap over the cable drum and under the *idrive*® disconnect cable. Align the outside flange over the outside edge of the cable drum and push the drum wrap down onto the cable drum.

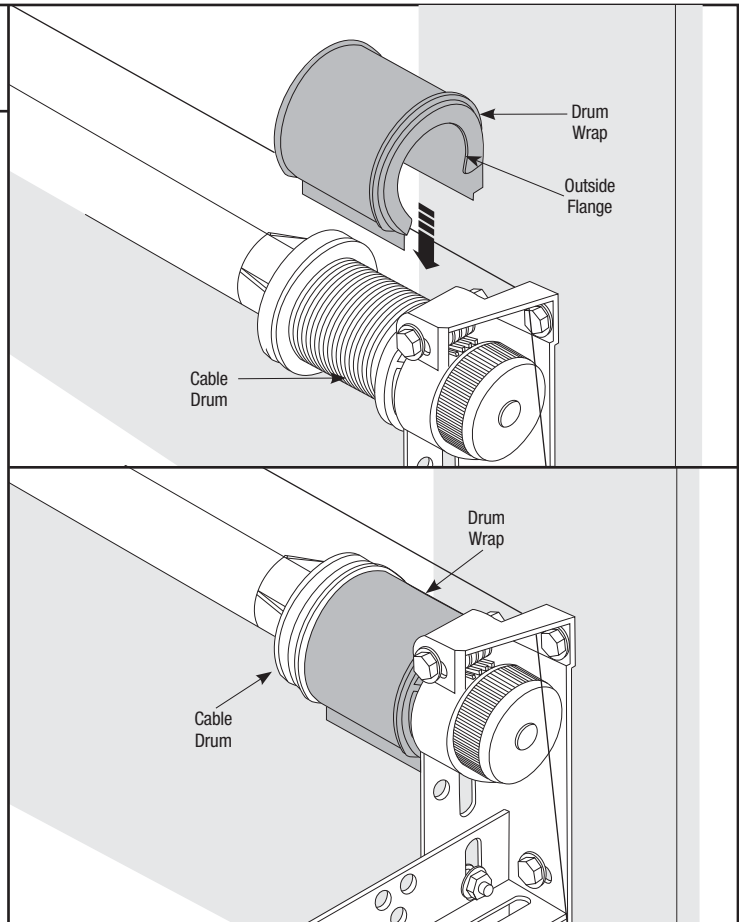

14

Mounting Wall Station

Tools Needed:
Tape Measure
Power Drill
3/16" or
3/32" Drill Bit
Phillips Head
Screwdriver

⚠ WARNING

TO PREVENT POSSIBLE INJURY, INSTALL WALL STATION OUT OF THE REACH OF CHILDREN AND IN A LOCATION WHERE THE DOOR CAN BE SEEN WHEN THE OPENER IS ACTIVATED. DO NOT MOUNT WALL STATION NEAR OR NEXT TO GARAGE DOOR.

NOTE: For proper operation, mount the wall station on a flat surface.

The wall station can be mounted to a NEMA standard electrical device box or directly to any wall surface. No wiring is required.

Select appropriate place to mount wall station. To keep wall station out of the reach of children, locate it at least five feet up from the floor.

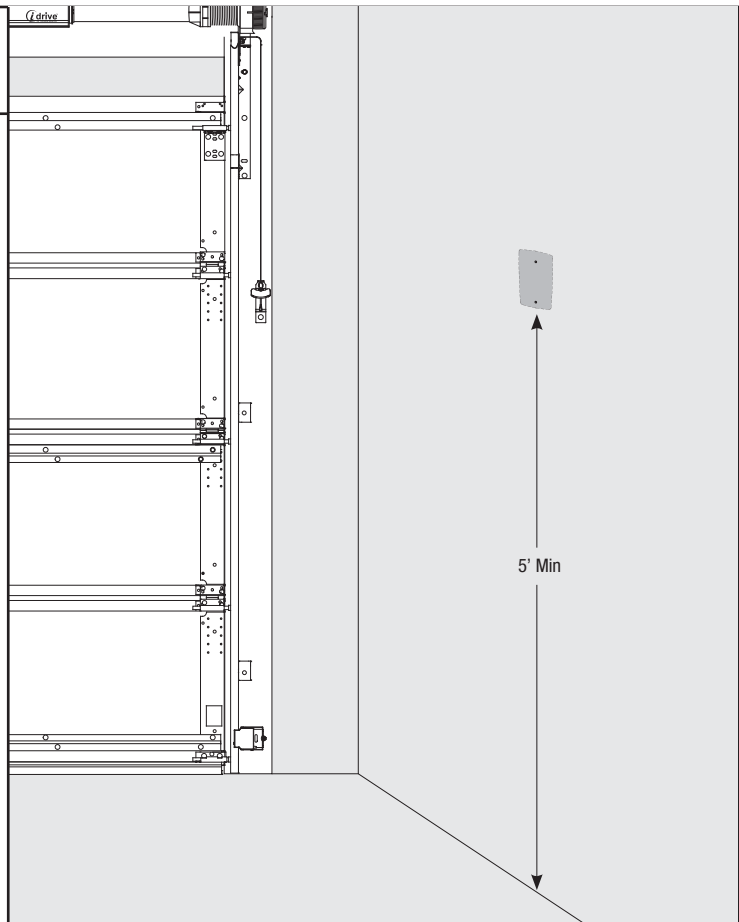

16

Installing the Light Fixture (If Included)

Tools Needed:

Phillips Head
Screwdriver

Flat Tip
Screwdriver

Step Ladder

⚠️ WARNING

TO AVOID ELECTRICAL SHOCK DISCONNECT POWER TO THE RECEPTACLE AT THE FUSE/BREAKER BOX, BEFORE PROCEEDING WITH THE INSTALLATION OF THE LIGHT FIXTURE.

IMPORTANT! THIS LIGHT FIXTURE HAS A GROUNDING TYPE PLUG WITH A THIRD (GROUNDING) PIN. THIS PLUG WILL ONLY FIT INTO A GROUNDING-TYPE OUTLET. IF THE PLUG DOES NOT FIT INTO YOUR OUTLET, CONTACT A QUALIFIED ELECTRICIAN TO INSTALL THE PROPER GROUNDING TYPE OUTLET. DO NOT ALTER THE PLUG IN ANY WAY.

⚠️ WARNING

TO AVOID ELECTRICAL SHOCK/FIRE, DO NOT MOUNT THE LIGHT FIXTURE TO A RECEPTACLE WITH A METAL FACE PLATE.

IMPORTANT! GARAGE DOOR MUST CLEAR LIGHT FIXTURE WHEN THE DOOR IS IN THE OPEN POSITION.

The light fixture is designed to mount directly to a standard 120V duplex receptacle.

Remove the screw in the receptacle cover. Holding receptacle cover in place, insert light fixture into the receptacle that has the ground hole farthest from screw hole.

Secure light fixture to receptacle with a #6-32 x 3/4" phillips pan head screw.

Install hole plug into the screw hole in the light fixture.

NOTE: For temperature protection, the hole plug must be in place prior to using the light fixture.

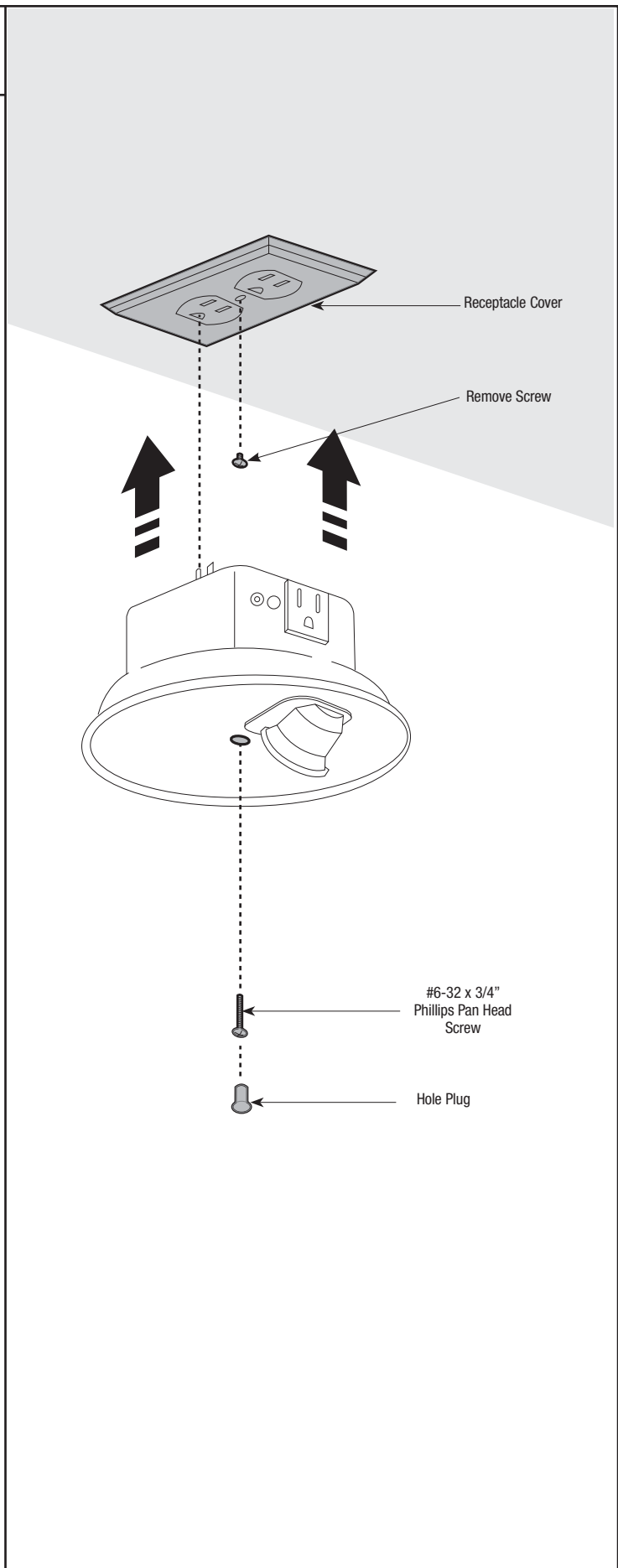

17

Attaching Diffuser (If Included)

Tools Needed:
Step Ladder

Screw a 75W (maximum) light bulb into light socket and snap diffuser into light fixture.

When assembling diffuser, make sure all three snap tabs are aligned and fully snapped into the three mating slots of the light fixture.

Turn receptacle power back on at fuse/breaker box. The light should blink one time when the power is turned back on.

NOTE: An accessory power outlet receptacle (600 Watt Maximum) is provided as part of the light fixture.

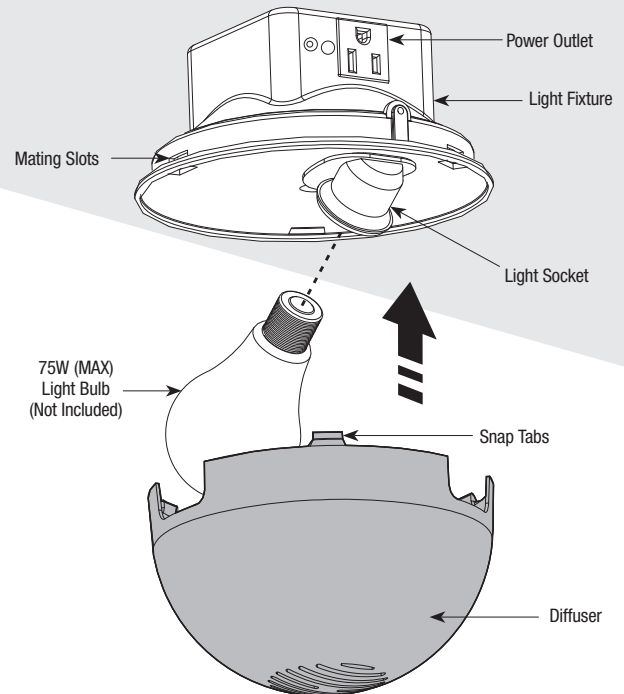

18

Connecting Opener Power Cord

Tools Needed:
Phillips Head
Screwdriver
Step Ladder

⚠ WARNING

TO REDUCE THE RISK OF ELECTRICAL SHOCK, DO NOT CHANGE THE POWER CORD PLUG IN ANYWAY.

The opener can be permanently wired. To permanently wire the unit, see Permanent Wiring option on page 39.

Plug the end of the power cord into the closest grounding type receptacle. Otherwise, contact a service person for further options. Excess power cord length must be routed and contained safely away from any moving parts.

As soon as power is applied to the opener, it should beep two times.

NOTE: Do not permanently attach power cord to building!

NOTE: Use only the flexible cable clips supplied with the opener.

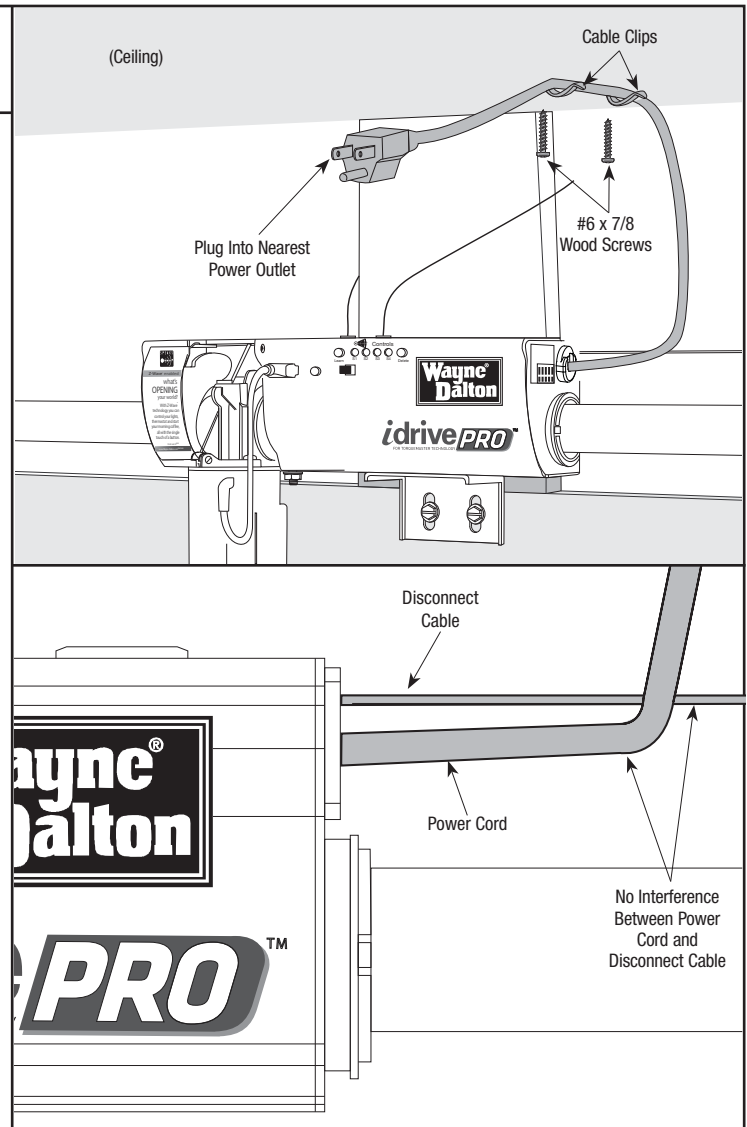

19

Safety Sensors Installation

8000 Series Doors (Required) (Not Required On 9000, 5120 & 5140 Series Doors)

Tools Needed:
Tape Measure
Power Drill
3/16" Bit
7/16" Socket Driver
7/16" Wrench
Pencil

NOTE (Per UL): Safety sensors are required if opener is installed on a non-pinch resistant door. If your door is a Wayne-Dalton 9000 series, 5120 or 5140 pinch resistant door, skip this step and proceed with Step 22.

WARNING

PHOTOELECTRIC EYES ARE NOT REQUIRED ON WAYNE-DALTON SERIES 9000 AND MODEL 5120 AND 5140 DOORS. ALL OTHER DOORS, WHICH DO NOT HAVE PINCH-RESISTANT SECTION JOINTS, REQUIRE PHOTOELECTRIC EYES TO PREVENT POSSIBLE SEVERE OR FATAL INJURY.

- a. Select and mark with a pencil, a suitable mounting location no more than **5 inches** above the floor to the center line of wall mounting bracket. The safety sensors should be mounted as close to the door track or inside edge of the door as possible to offer maximum entrapment protection. It is very important that both wall mounting brackets be mounted at the same height for proper alignment.

IMPORTANT! BOTH WALL BRACKETS MUST BE MOUNTED AT THE SAME HEIGHT FOR PROPER ALIGNMENT.

- b. Drill pilot holes, using a 3/16" drill bit. Using two 5/16" x 1-1/2" lag screws, permanently mount the wall mounting brackets to both door jambs. In some installations it may be necessary to attach a wooden spacer to the wall to achieve the required alignment.

Attach the "U" brackets to the wall mounting brackets with 1/4"-20 x 1/2" carriage bolts, washers and nuts. Insert the bolts from the inside of the "U" bracket and hand-tighten.

- c. Attach the sending and receiving safety sensors to the "U" brackets by inserting all three tabs into the respective holes.

IMPORTANT! IDENTIFY WHICH SIDE OF THE GARAGE DOOR IS EXPOSED TO THE MOST SUNLIGHT. MOUNT THE SENDING UNIT (UNIT WITHOUT LED) ON THE SIDE WHICH IS EXPOSED TO THE MOST SUN. SUNLIGHT MAY AFFECT THE SAFETY SENSORS, AND THIS POSITIONING WILL HELP REDUCE THE ADVERSE EFFECT SUNLIGHT MAY HAVE ON THE SENSOR UNIT.

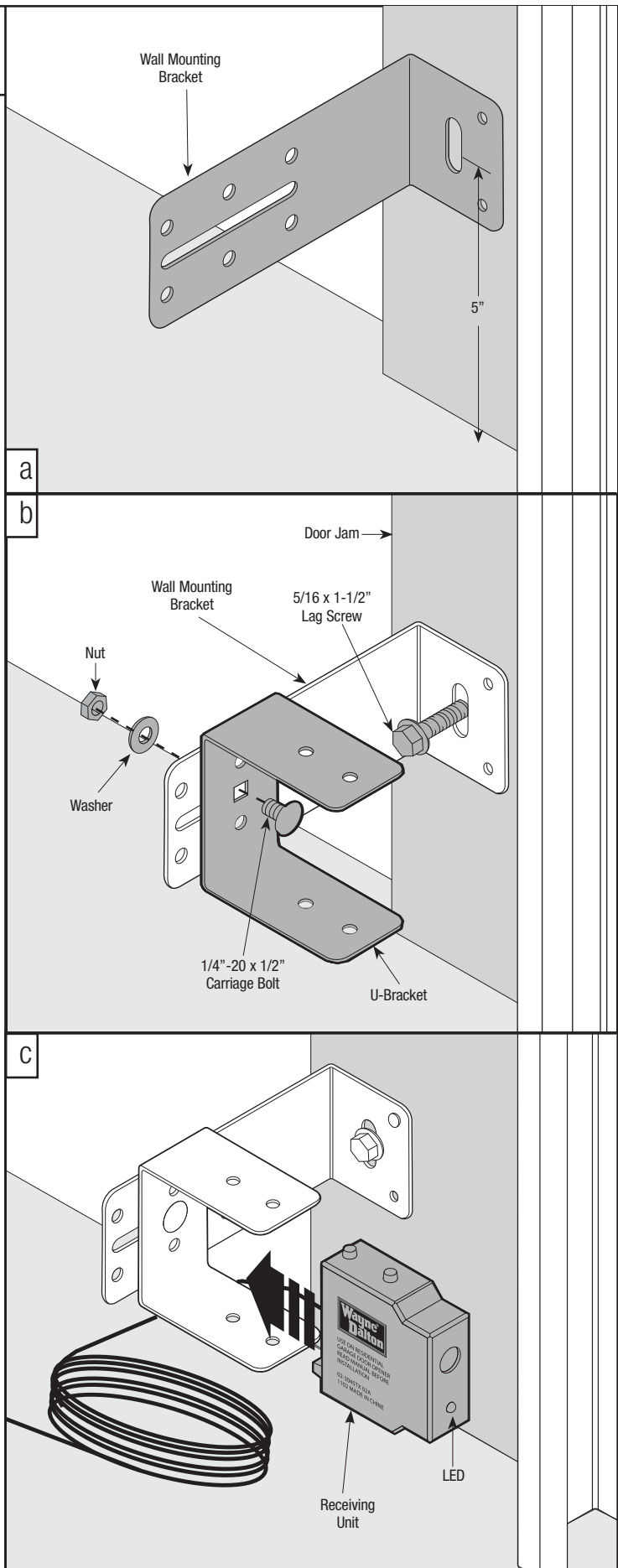

20

Sensor Wire Installation (Required on all 8000 Series and other Non Pinch Resistant Doors)

Tools Needed:

Flat Tip
Screwdriver
Pliers/Wire
Cutters

Uncoil wires from photoelectric sensors and route wires up garage wall and along door header towards the right side of the opener.

Route wires behind torque tube and tack wires in place with insulated staples (not supplied). Take care to run wires in a location where they will not interfere with the operation of the door.

Do Not Staple Through Wire.

NOTE: If wires must be lengthened or spliced use wire nuts or suitable connectors.

NOTE: Take care to run wires in a location where they will not interfere with the operation of the door and do not staple through wire.

Connect photoelectric sensors to the opener terminal block on right side of the opener. Separate wire ends and strip about 1/2" of insulation off each of the wire ends.

Insert a 3/32" (2.5mm) max. width flatblade screwdriver into the lower hole #1 of the terminal block. Twist screwdriver to open wire clamp in upper hole #1 of terminal block. Insert both sender and receiver solid white wires into upper hole #1 until the wires bottom out and release screwdriver tension. Insert and twist screwdriver in lower hole #2 and insert both sender and receiver wires (white with black stripe) into upper hole #2 until wires bottom out and release screwdriver tension. Be sure to observe polarity.

Once wires are connected, install jumper through the front opener cover on to the pins labeled PE.

IMPORTANT! KEEP SENDER/RECEIVER WIRES AWAY FROM MOVING COMPONENTS.

Lightly pull on external wires to test for secure connection. Check that the wires are stapled in place and staples have not cut wire insulation.

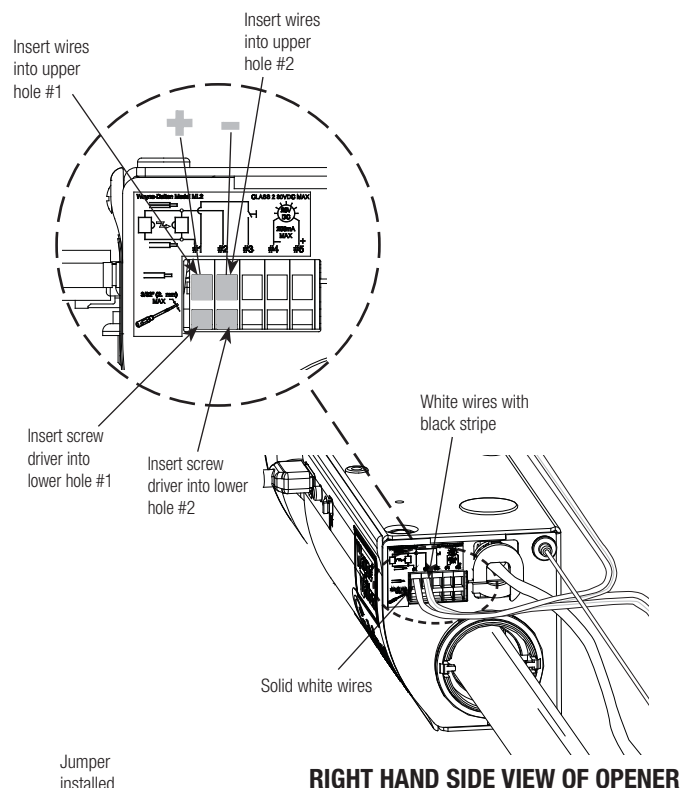
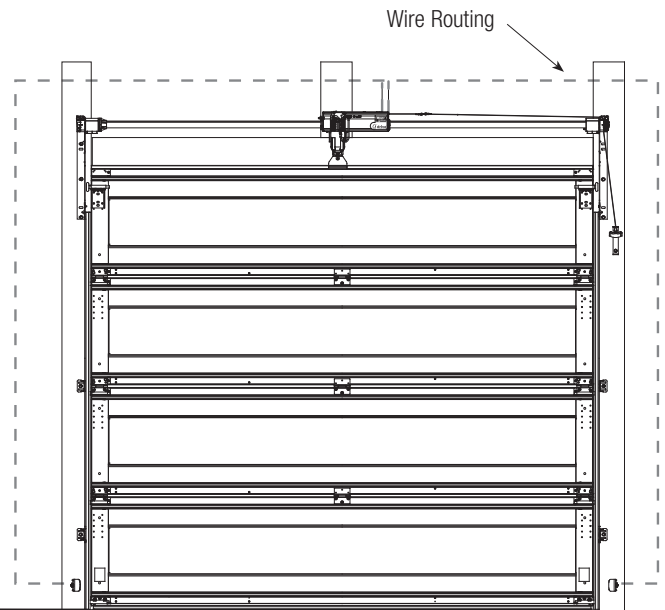

RIGHT HAND SIDE VIEW OF OPENER

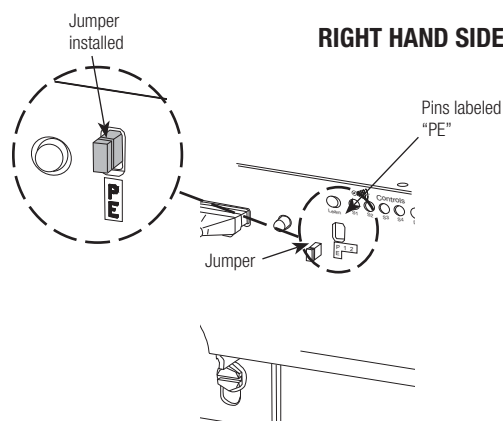

VIEW OF THE OPENER FROM THE FRONT

21

Safety Sensor Alignment

Tools Needed:
Pliers

Align the safety sensors by moving the sending and receiving units in or out until the alignment light on the receiving unit comes on. The 1/4"-20 carriage bolt can be loosened to move the safety sensor in or out, as required. If you have difficulty aligning the beams, check that both mounting brackets are mounted at the same height and remount if necessary. Additional minor adjustments can be made by slightly bending the mounting brackets.

Once the alignment light comes on, tighten all bolts and mounting screws. Finish securing all wires making sure not to break or open any of the conductors. Loop and secure any excess wire.

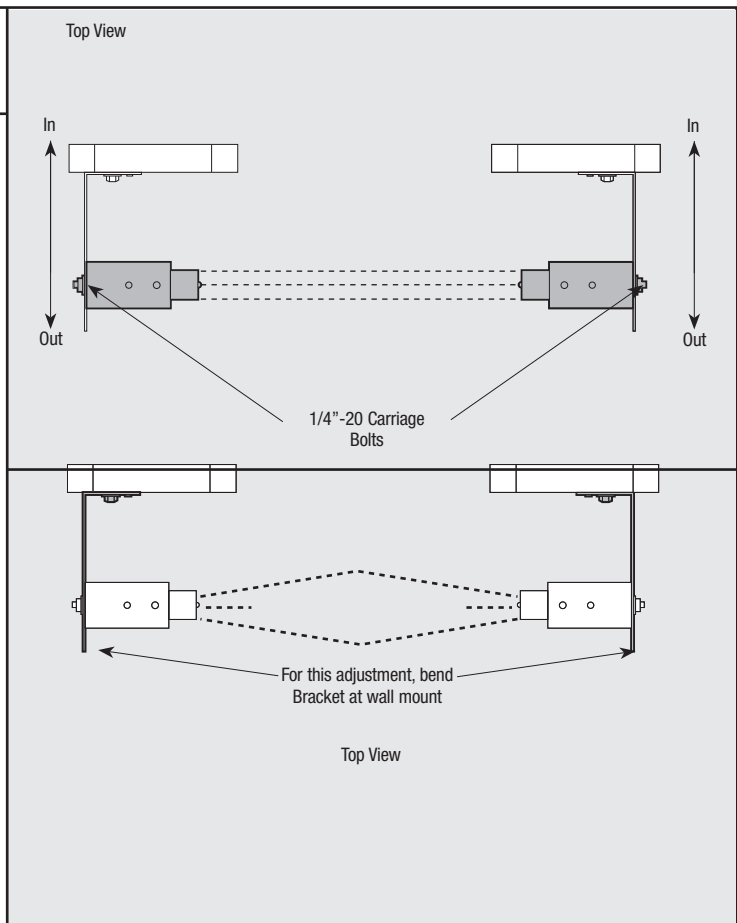

22

Securing the Opener and Checking for Obstructions

Tools Needed:
7/16" Wrench
Step Ladder

With the emergency disconnect still in the manual door operated position, manually raise the door to the fully open position. Then, manually lower the door to the fully closed position verifying freedom of movement and good door balance.

Tighten both 1/4"-20 flange nuts, securing the opener to the support bracket.

NOTE: Good door balance and freedom of movement are essential for proper opener performance. If door is heavy to lift, hard to close or if door sticks or binds in the track, make proper adjustments now.

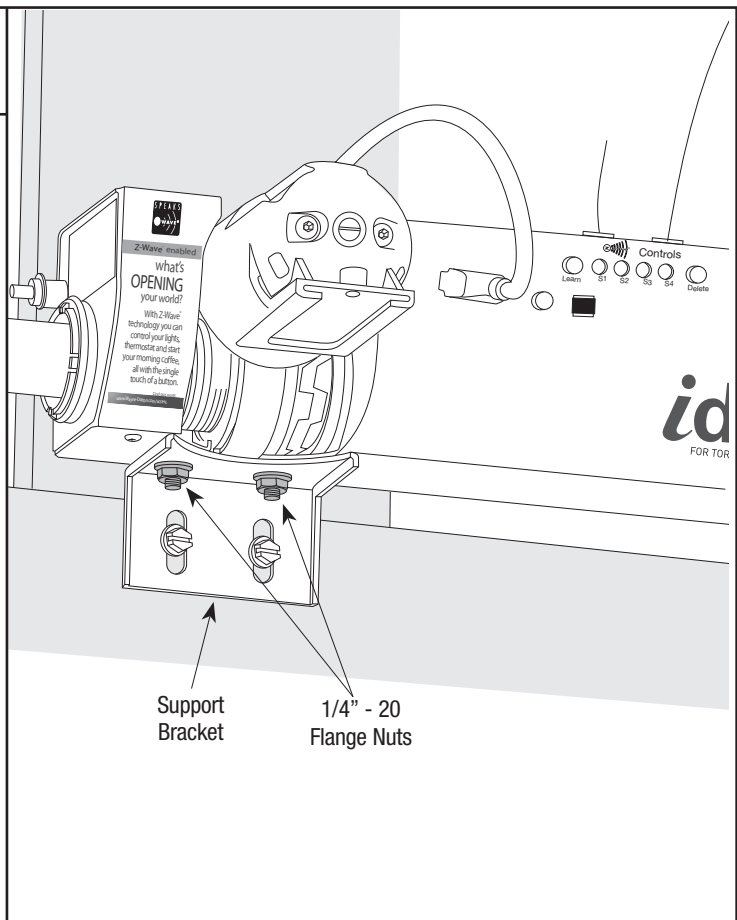

23

Programming Light Fixture (If Included)

Tools Needed:
Step Ladder

Press the red program button on the light fixture. The LED on the light fixture will turn on and remain on for 30 seconds or until a opener is learned to the light fixture. The incandescent lamp will also turn on when program button is pushed.

Press the light button on the wall station. This must be done within 30 seconds of pressing the program button on the light fixture. The light fixture lamp and LED will blink three times to indicate successful programming. The light fixture can now be turned on and off from this wall station.

NOTE: In order to program the opener to the light fixture, the installer must have the wall station already programmed to the opener.

Program Button LED

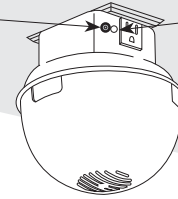

Light Button



24

Profile Routine (Standard Upper Limit)

Tools Needed:
None

⚠ WARNING

TO AVOID INJURY, NO ONE SHOULD CROSS THE PATH OF A MOVING DOOR!

The profile routine automatically sets the door open and close limits and calibrates obstruction sensing. During the profile routine, the door will move up and down twice.

NOTE: If an object such as a ceiling beam obstructs the door from opening completely, skip this step. Set a Custom Upper Limit, see Step 25.

NOTE: The door must be in its fully closed position and the disconnect handle must be in the motor operated position (upper position) to initiate the profile routine.

NOTE: Profile routine will not run if safety sensors are not aligned (only if required installation).

Press and hold the profile button for five (5) seconds. The opener will beep twice, release the profile button, indicating the activation of the profile routine. The door will now move to the fully open position and stop, beep twice and then the door will close completely.

Next, the door will go through one more up/down cycle. Once this is complete, the door limits are set and the profile is complete.

NOTE: Upon successful completion proceed to Step 26.

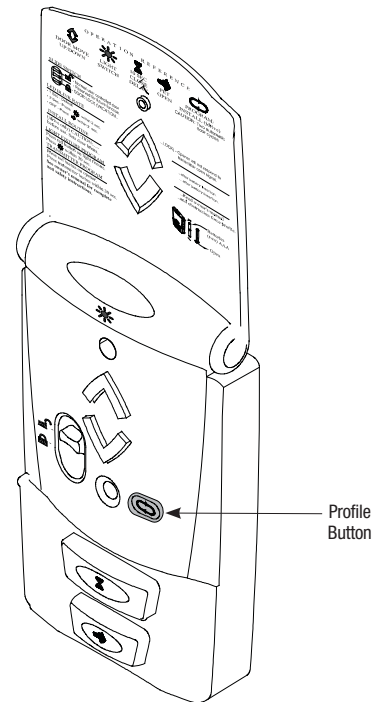

Profile Button

25

Profile Routine (Custom Upper Limit)

Tools Needed:
None

⚠️ WARNING

TO AVOID INJURY, NO ONE SHOULD CROSS THE PATH OF A MOVING DOOR!

NOTE: If no obstruction interferes with a standard upper limit, skip this step.

NOTE: The door must be in its fully closed position and the disconnect handle must be in the motor operated position (upper position) to initiate the profile routine.

NOTE: Install profile will not run if safety sensors are not aligned (Only if required for your door).

Press and hold the profile button for five (5) seconds. The opener will beep twice, release the profile button, indicating the activation of the profile routine.

When the door moves to the desired upper limit, press and hold the Up/Down button on the wall station until the door stops. Next, the door will close completely. The Up/Down button (when door is closed) can be activated by pressing center of flip cover.

Next, the door will go through one more Up/Down cycle. Once this is complete, the door limits are set and the profile is complete.

Alternately, once a profile routine has been successfully completed, disconnect door and manually move to desired upper limit. Re-connect door and **press and hold the profile button for five (5) seconds.** The door will close, open and close to complete the profile routine with the new custom upper limit.

NOTE: For a more precise location of the custom upper limit, see "Customizing the Settings" on page 37.

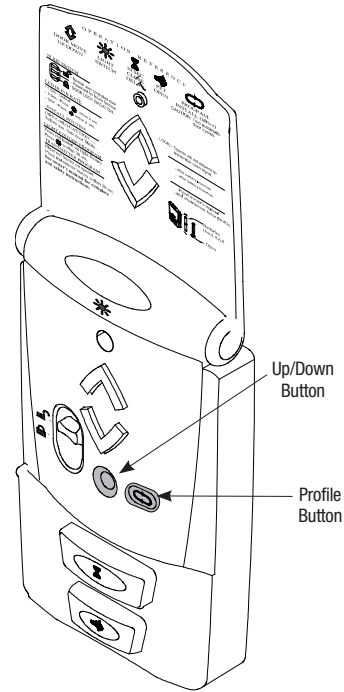

26

Adjusting Detent

Tools Needed:
Flat Tip
Screwdriver
Step Ladder

The amount of pressure the opener uses to pivot the motor downward is preset at the factory via the detent pin adjustment screw.

Due to variations in door installations, a detent pin adjustment may need to be made in order to insure proper pivoting of the motor.

IMPORTANT! FOR SYSTEM SECURITY: THE MOTOR IS DESIGNED TO PIVOT DOWN AFTER THE DOOR CLOSES COMPLETELY. IF THE MOTOR DOES NOT PIVOT OR PIVOTS TOO SOON, THE DETENT PIN ADJUSTMENT SCREW MAY NEED TO BE ADJUSTED IN ORDER FOR THE DOOR LOCK FEATURE TO WORK PROPERLY.

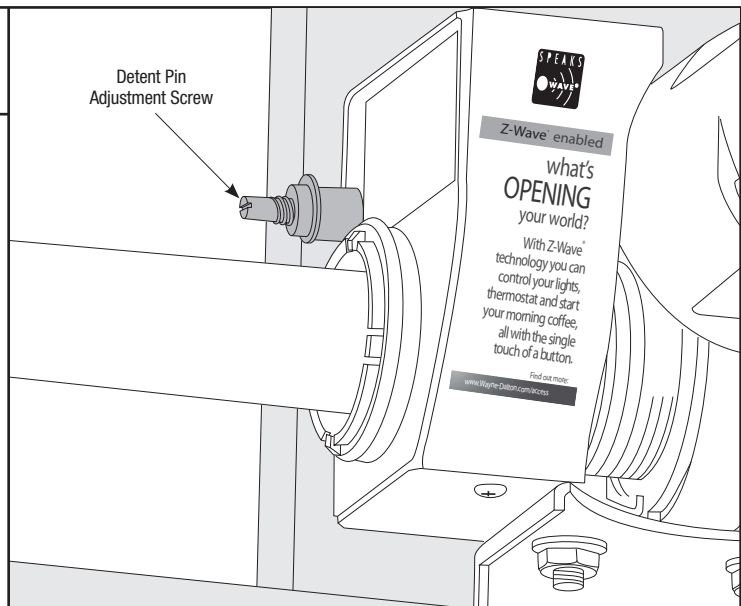

PRE-OPERATION

Adjusting Detent (Continued)

- a.** If the motor does not pivot down, or only pivots down partially, the detent pin is set too hard.
- Using a flat tip screwdriver, turn the detent pin counterclockwise in 1/8 turn increments.
- Operate the door to confirm adjustment.
- Repeat procedure until motor pivots to full down position when the door is completely closed.
- b.** If the motor pivots down prematurely (before the door is completely closed) or if the motor is “slapping” too aggressively against the top of the door, the detent pin is set too soft.
- Using a flat tip screwdriver, turn the detent pin clockwise in 1/8 turn increments.
- Operate the door to confirm adjustment.
- Repeat procedure until motor pivots to full down position when the door is completely closed.

a
b

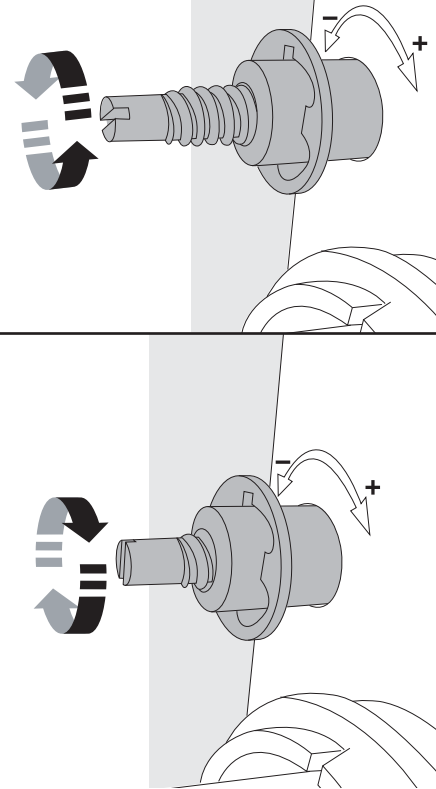

27

Lock Arm Installation

Tools Needed:
Tape Measure
Step Ladder

NOTE: If you have a low headroom double track system, skip this step and continue with Step 28.

Place the emergency disconnect in the manual operated position, Motor will pivot to the up position (see Step 9).

Insert the lock arm into the motor groove and align with the proper hole depending on your track radius. To determine the Wayne-Dalton track radius being used, measure the length of the flagangle and Torquemaster® end bracket and compare to the diagram on the right (all Portland tracks are stamped with radius on the side of the track).

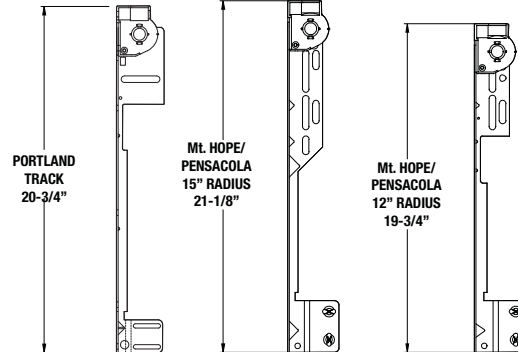
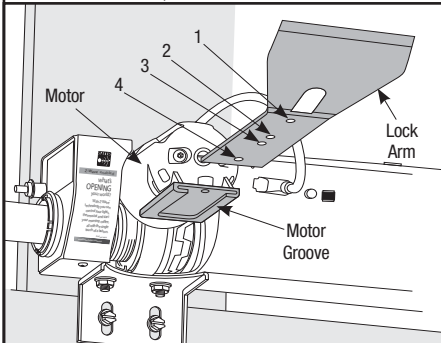

Lock Arm Position	Track Type WD - Mt. Hope & Pensacola PO - Portland	Track Radius	Door Model
1	WD	15" (380mm)	9700
	WD	12" (305mm)	8000, 9000
	PO	12"	9000 Series
	PO	10"	8000, 9000
2	PO	12"	8000 Series
3	WD	15" (308mm)	8000, 9000
	PO	14"	9000 Series
4	PO	14"	8000 Series

Lock Arm Installation (Continued)

Once track radius has been determined, secure the lock arm to the motor with (1) 5mm x .8mm phillips pan head screw.

NOTE: If unsure of track radius, begin with lock arm in position 1.

After assembly of the lock arm, manually raise and lower the door and verify that the lock arm does not interfere with the door. If there is interference between the door and the lock arm, see Page 42 for lock arm troubleshooting.

NOTE: Do not operate the door or opener if there is interference between the lock arm and the door.

Reconnect the door to the motor operated position. Activate a motor operated up/down cycle to confirm clearance.

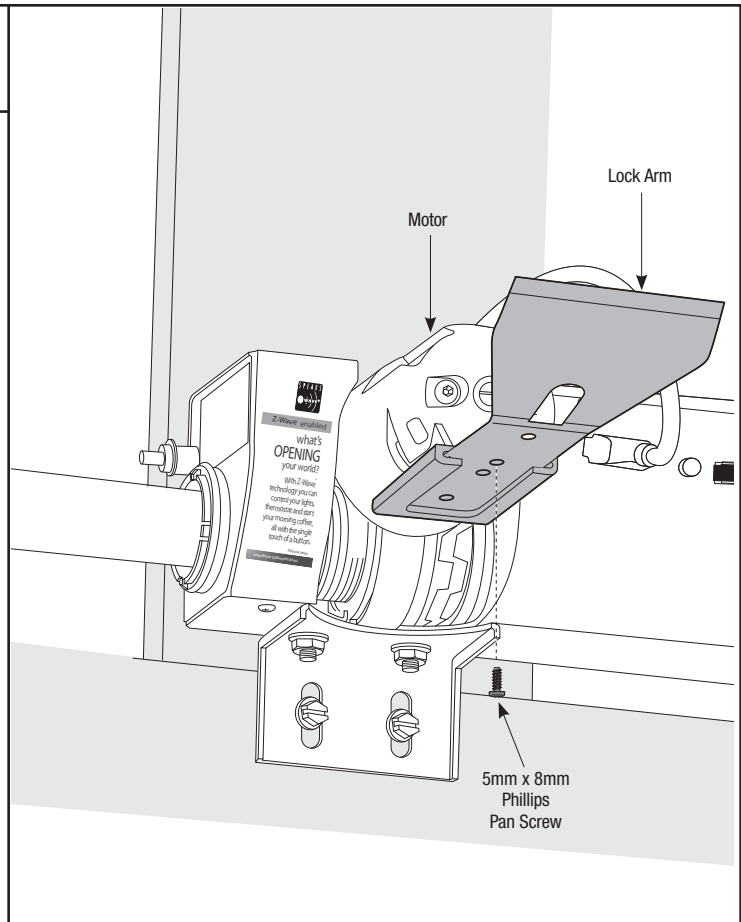

28

Contact Obstruction Test

Tools Needed:
2 x 4 Board

After installing the opener, the door must reverse when it contacts a 1-1/2" high object (or a 2 x 4 board laid flat) on the garage floor.

Using the wall station, activate the door to the fully open position.

Place a 2 x 4 board flat on the garage floor, under the door path.

Activate the door to the closed position with the wall station. Upon contacting the 2 x 4 board, the door should stop, then reverse direction within two seconds and travel to the full open position.

If the door does not respond to the required tests, repeat profile routine Step 24 or 25, making sure the door is in the fully closed position prior to activation.

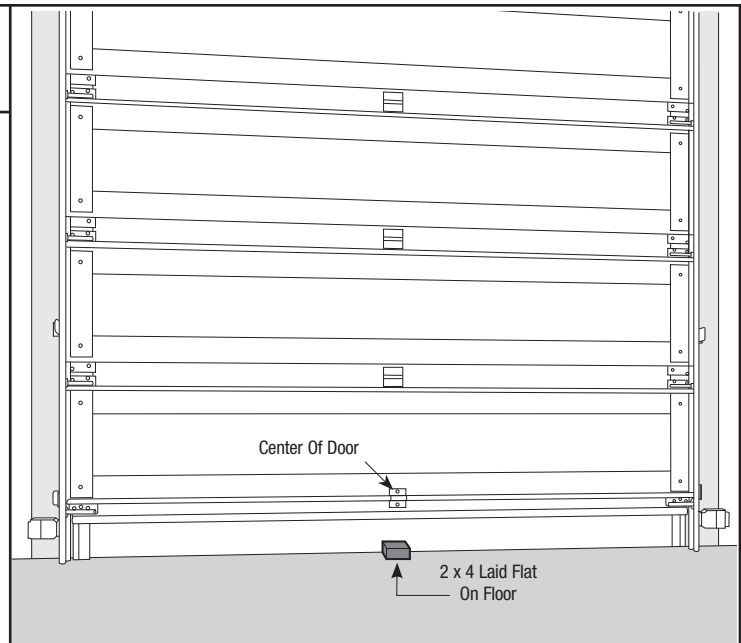

WARNING

IF OPENER DOES NOT RESPOND PROPERLY TO THESE TESTS (STEPS 28 AND 29), DO NOT USE DOOR UNTIL A QUALIFIED SERVICE PERSON HAS MADE NECESSARY ADJUSTMENTS/REPAIRS, OR SEVERE OR FATAL INJURY COULD RESULT FROM OPERATING THE DOOR/OPENER.

PRE-OPERATION

30

Testing the Safety Sensors (If Installed)

Tools Needed:
6" Height Object

⚠ WARNING

WHEN PERFORMING THIS PART OF THE TEST, DO NOT PLACE YOURSELF UNDER DESCENDING DOOR, OR SEVERE OR FATAL INJURY MAY RESULT.

Starting with the door fully open, place a 6" high object on the floor, in line with sensors, one foot from the left side of the door.

Activation of the opener with the wall station Up/Down button should cause the door to move no more than one foot, stop and then reverse to fully open position.

Repeat this test with the 6" high object placed at the center of the door and then one foot from the right side of the door.

The 6" high object, when placed on the floor in line with sensors, while door is closing, should also cause the door to reverse.

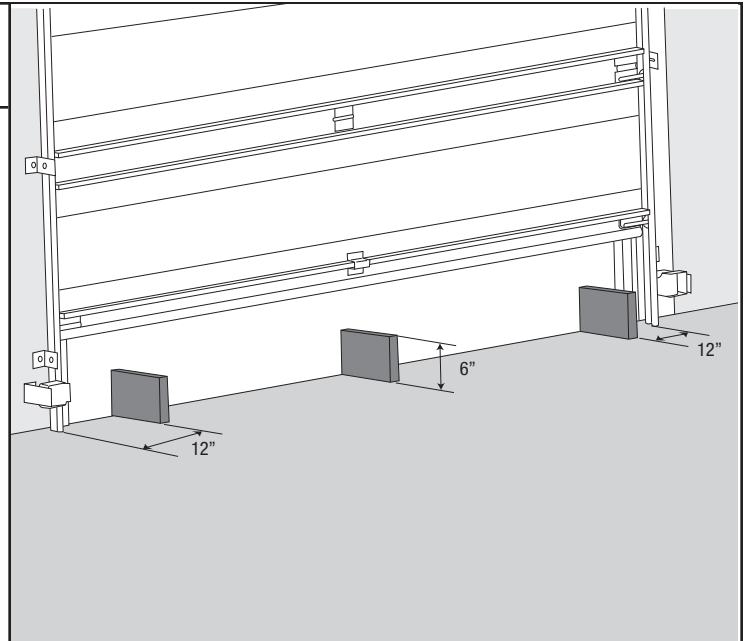

⚠ WARNING

IF OPENER DOES NOT RESPOND PROPERLY TO THESE TESTS (STEPS 28 AND 29), DO NOT USE DOOR UNTIL A QUALIFIED SERVICE PERSON HAS MADE NECESSARY ADJUSTMENTS/REPAIRS, OR SEVERE OR FATAL INJURY COULD RESULT FROM OPERATING THE DOOR/OPENER.



IMPORTANT SAFETY INSTRUCTIONS

⚠ WARNING TO REDUCE THE RISK OF SEVERE INJURY OR DEATH:

- 1. READ AND FOLLOW ALL INSTRUCTIONS.**
- Never let children operate or play with the door controls. Keep remote controls away from children.
- Always keep a moving door in sight and keep people and objects away until it is completely closed. NO ONE SHOULD CROSS THE PATH OF A MOVING DOOR.
- NEVER GO UNDER A STOPPED, PARTIALLY OPEN DOOR.
- Test the Door/Opener monthly. The garage door MUST reverse on contact with a 1-1/2" high object (or a 2 x 4 board laid flat) on the floor. The door MUST also reverse when a 6" high object is placed on the floor in line with safety sensors. If Door/Opener fails these tests, have adjustments/repairs made immediately. Failure to make adjustments/repairs may cause severe or fatal injury.
- When possible, use the Emergency Disconnect only when the door is in the closed position. Be very cautious using the Emergency Disconnect when the door is open. Weak or broken spring(s) may allow the door to fall rapidly, causing a severe or fatal injury.
- KEEP THE GARAGE DOOR PROPERLY BALANCED. See the owner's manual included with the door. An improperly balanced door could cause a severe or fatal injury. Have a qualified service person make repairs to the cables, spring assemblies, and other hardware.
- 8. SAVE THESE INSTRUCTIONS.**

Door activation:

Upon activation by either the Wall Station Up/Down Button or Transmitter, the door will move in the following manner:

- If closed, the door will open. If open completely, the door will close. If partially open, the door will close.
- If closing, the door will stop, reverse, and return to the open position. Next activation will close the door.
- If opening, the door will stop. Next activation will close the door.
- If an obstruction is encountered or an out-of-balance condition is detected while the door is closing, the door will reverse, return to the open position, and the opener will beep 3 or 4 times. The next activation will close the door.
- If an obstruction is encountered or an out-of-balance condition is detected while opening the door, the door will stop. The next activation will close the door.
- When door is in motion any button on the wall station functions the same as the Up/Down button.

⚠ WARNING

ALWAYS KEEP MOVING DOOR IN SIGHT AND KEEP PEOPLE AND OBJECTS AWAY UNTIL IT IS COMPLETELY CLOSED. TO PREVENT A SEVERE OR FATAL INJURY, AVOID STANDING IN A OPEN DOOR WAY OR WALKING THROUGH THE DOORWAY WHILE THE DOOR IS MOVING.

⚠ WARNING

NEVER LET CHILDREN OPERATE DOOR OR PLAY WITH THE DOOR CONTROLS. KEEP REMOTE CONTROLS AWAY FROM CHILDREN. FATAL INJURY COULD RESULT SHOULD A CHILD BECOME TRAPPED BETWEEN THE DOOR AND FLOOR.

⚠ WARNING

KEEP THE GARAGE DOOR PROPERLY BALANCED. AN IMPROPERLY BALANCED DOOR COULD CAUSE SEVERE OR FATAL INJURY. HAVE A QUALIFIED SERVICE PERSON MAKE ADJUSTMENTS/REPAIRS TO CABLES, SPRING ASSEMBLIES, AND OTHER HARDWARE.

Emergency Disconnect:

⚠ WARNING

THE EMERGENCY DISCONNECT SHOULD ONLY BE USED WHEN DOOR IS CLOSED. USE EXTREME CAUTION IF OPERATING THE EMERGENCY DISCONNECT ON AN OPEN DOOR. WEAK OR BROKEN SPRING(S) MAY ALLOW THE DOOR TO FALL RAPIDLY, CAUSING SEVERE OR FATAL INJURY.

The opener is equipped with an emergency disconnect that allows the door to be moved manually and independently from the opener.

With the door closed, pull down on the disconnect handle and place the handle under the lower section of the handle bracket. This motion causes the motor on the opener to pivot upwards and the opener to disconnect from the torque tube.

Releasing the disconnect handle from the lower section on the handle bracket and returning the handle to its original position will reconnect the opener to the torque tube.

NOTE: The motor will not pivot down completely when the handle is released. After one motorized up/down door cycle, the motor will once again pivot down, and all cable slack will be taken up. The garage door is not secured from forced entry until the motor is back in the down position.

Disconnect Label: The label is located next to the disconnect handle. The label shows the handle in both the motor operated and manual operated positions. View on the left side of the label shows the handle position when the opener is engaged to the torque tube. The view on the right side of the label shows the handle when the opener is disconnected from the torque tube.



Operating the Wireless Wall Station

Up/Down Button:

Momentarily pressing the Up/Down button activates the door. If an out-of-balance condition causes the door to stop while opening or reverses the door while closing, apply constant pressure to the Up/Down button until the door is fully open or closed. This will allow the opener to move the door in an out of balance condition, until the problem is corrected (see Troubleshooting). The Up/Down button (when unit is closed) can be activated by pressing flip cover.

⚠ WARNING

THE SEVERE OUT-OF-BALANCE CONDITION MUST BE CORRECTED IMMEDIATELY. FAILURE TO MAKE ADJUSTMENTS/REPAIRS, COULD RESULT IN SEVERE OR FATAL INJURY.

Light Button:

Momentarily pressing the Light Button turns on the light fixture. The light fixture will remain on until either the Light Button is pressed again or the door is activated. The light fixture automatically turns on with a door activation and remains on for five minutes. Pressing the light fixture button before the five minutes has elapsed will turn off the light fixture. While the door is in motion, the Light Button functions identically as the Up/Down button, stopping or reversing the door immediately.

Timer Button:

Momentarily pressing the Timer Button causes a delayed activation of a stationary fully open door. The opener will signal seven beeps (approx. 8 seconds) then beep constantly for two seconds prior to closing the door, allowing time to exit the garage when the opener is in the timer mode. Pressing any button, except for the profile button while the opener is beeping cancels the timer mode.

NOTE: The Timer feature will only function with the door in the full open position. Pressing the Timer Button with a stationary door in any other position will cause the opener to beep four times and the door will not be activated.

While the door is in motion, the Timer Button functions identically as the Up/Down button, stopping or reversing the door immediately.

Slide Switch:

The Slide Switch has two positions: Normal, and Door lock.

Normal position: 

Move the Slide Switch to normal position for all normal functions of the opener. The normal position will cancel the door lock feature.

NOTE: When the Slide Switch is moved to the unlocked position the opener will beep once.

Door Lock position: 

If the door is stopped (fully open, fully closed or partially open) move the Slide Switch to the door lock position to suspend all normal functions of the opener. The opener will remain completely disabled and non-operational in this mode. All wall stations, transmitters and keyless entry units are ignored until the Slide Switch is moved to the normal position. If the door is moving when the Slide Switch is moved to the door lock position, the door lock mode is not activated and all functions of the opener remain active.

NOTE: When the Slide Switch is moved to the locked position the opener will beep twice.

Backlit LED Light:

The red LED blinks intermittently to help you locate the wall station in a dark garage. This blink rate can be changed for longer battery life or can be turned off. The default blink rate is one blink every 3 seconds. For longer battery life the blink rate can be changed to blink once every 6 seconds. To change the blink rate, remove the battery cover and remove one battery. Re-install the battery and within 2 seconds, press the Light button. Re-install the battery cover.

For longest battery life, the blink can be turned off. To turn off the blink, remove the battery cover and remove one battery.

Re-install the battery and within 2 seconds, press the pet button. Re-install the battery cover.

NOTE: The wall stations red LED will light while any wall station button remains pressed.

Pet Position:

Pressing the Pet button opens a closed door to a preset position between eight and thirty inches above the floor, allowing pets to enter and exit the garage without the door being fully open. The door must be fully closed to activate the pet open feature. Pressing the Pet button with a stationary door in the pet open position will cause the door to close. Pressing the Up/Down button while the door is in the pet position will cause the door to open. While the door is in motion, the pet button functions identically to the Up/Down button, stopping or reversing the door immediately. The pet feature allows for custom setting of the pet position door height. See Customizing the Settings on page 37.

NOTE: A door in the "pet position" (open 8-30 inches) is not locked and should not be used as a secured door position.

Profile Routine:

Press and hold the Profile button for 5 seconds to initiate the "Profile Routine". See Customizing the Settings on page 37.

NOTE: The wall stations red LED will light while any wall station button remains pressed. See Maintenance section for battery replacement.

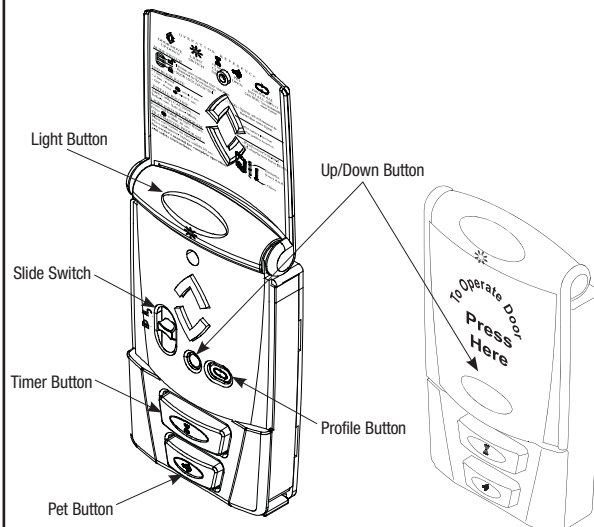



Programming HomeLink® System to the Torquemaster® iDrive® (Primary)

NOTE: This step can only be done on automobiles equipped with the HomeLink® system.

NOTE: Programming HomeLink® requires a Wayne-Dalton Transmitter that is programmed to the opener (the wallstation and transmitter(s) supplied with the opener, come pre-programmed from the factory). Any additional wallstation(s) or transmitter(s) will need to be programmed to the opener, see page 40.

IMPORTANT! Use the programming instructions provided with your vehicle first. Follow these instructions if the HomeLink® unit does not learn the transmitter, when using the vehicle's instructions.

NOTE: If Primary programming does not work then use the Alternate procedure on next page.

NOTE: Vehicle may need to be in accessory position when programming. Check car owner's manual.

NOTE: HomeLink® is a registered trademark of Johnson Controls.

Programming/Training HomeLink® Unit

⚠ WARNING

GARAGE DOOR MAY OPERATE DURING PROGRAMMING. TO AVOID POSSIBLE SEVERE OR FATAL INJURY, PLACE THE EMERGENCY DISCONNECT HANDLE IN THE MANUAL OPERATED POSITION.

1. Pull the manual disconnect to put the opener in the disengaged position.
2. Verify the HomeLink® unit has an empty channel – press the desired HomeLink® button and observe the LED – if it flashes slowly, the channel is empty and ready for programming. If pressing the desired channel/button causes the LED to blink rapidly, or come on without blinking this channel is already programmed. You either need to choose a different channel/button on the HomeLink®, or perform Step 3 below.
3. **OPTIONAL** – To completely clear all channels on the HomeLink® unit, press and hold the two outside buttons on the HomeLink® unit until the HomeLink® LED light begins to flash rapidly (approx. 20 seconds), then release both buttons. (Do not perform this step to train additional hand-held transmitters.) **NOTE:** This operation erases all previously learned transmitters and you will need to re-teach any other transmitters to your HomeLink® unit.
4. Hold the end of the Wayne Dalton hand-held transmitter approximately 1 to 3 inches away from the HomeLink® surface – keeping the HomeLink® indicator light in view.
5. Simultaneously press and hold the Wayne Dalton transmitter large button and desired button on the HomeLink® module, continue to hold both buttons. In less than 10 seconds the LED on the HomeLink® module will either go solid or give a single quick flash, release both buttons when either occur.

NOTE: If this procedure is unsuccessful, perform Alternate procedure on next page.

Teaching HomeLink® to the iDrive® opener

6. Press and release the red program button on the iDrive® opener. The iDrive® unit will beep once, indicating that it is ready to learn.

NOTE: The iDrive® will remain in the learn mode for 30 seconds.

7. Press the HomeLink® button used in Step 5 above for 1 to 3 seconds. The iDrive® will beep indicating a successful learn.
8. Return the manual disconnect to the engaged position.
9. Press the HomeLink® button once more to operate the door.

NOTE: The first transmitter command after programming will only move the door through a six inch up/down cycle. Normal door operations will occur on the second use of the transmitter.



Programming HomeLink® System to the Torquemaster® *idrive*® (Alternate)

NOTE: This Step can only be done on automobiles equipped with the HomeLink® system.

NOTE: Programming HomeLink® requires a Wayne-Dalton Transmitter that is programmed to the opener (the wallstation and transmitter(s) supplied with the opener, come pre-programmed from the factory). Any additional wallstation(s) or transmitter(s) will need to be programmed to the opener, see page 40.

IMPORTANT! Use the programming instructions provided with your vehicle first. Follow these instructions if the HomeLink® unit does not learn the transmitter, when using the vehicle's instructions.

NOTE: Vehicle may need to be in accessory position when programming. Check car owner's manual.

NOTE: HomeLink® is a registered trademark of Johnson Controls.

Programming/Training HomeLink® Unit

WARNING

GARAGE DOOR MAY OPERATE DURING PROGRAMMING. TO AVOID POSSIBLE SEVERE OR FATAL INJURY, PLACE THE EMERGENCY DISCONNECT HANDLE IN THE MANUAL OPERATED POSITION.

1. Pull the manual disconnect to put the opener in the disengaged position.
2. Press and hold the two outside buttons on the HomeLink® unit until the HomeLink® light begins to flash rapidly (approx. 20 seconds), then release both buttons. (Do not perform this step to train additional hand-held transmitters.) **NOTE:** This operation erases all previously learned transmitters and that you need to re-teach any other transmitters to your HomeLink® unit by repeating steps 3 - 6 below.
3. Hold the end of the Wayne®Dalton hand-held transmitter approximately 1 to 3 inches away from the HomeLink® surface – keeping the HomeLink® indicator light in view.
4. Use the large button on the Wayne Dalton transmitter. Simultaneously press and hold desired Homelink® button and the Wayne Dalton transmitter large button. Continue to press both buttons counting LED flashes on the HomeLink® module; between 50 to 60 LED flashes the LED will either come on solid or do one “quick flash”; when either of these occur release both Wayne Dalton transmitter and HomeLink® buttons.

Teaching HomeLink® to the *idrive*® Opener

5. Press and release the red program button on the *idrive*® opener. The *idrive*® unit will beep, indicating that it is ready to learn.
- NOTE:** The *idrive*® will remain in the learn mode for 30 seconds.
6. Press the HomeLink® button used in Step 4 above for 1 to 3 seconds. The *idrive*® will beep indicating a successful learn.
 7. Return the manual disconnect to the engaged position.
 8. Press the HomeLink® button once more to operate the door.

NOTE: The first transmitter command after programming will only move the door through a six inch up/down cycle. Normal door operations will occur on the second use of the transmitter.



Customizing the Settings

Custom pet position:

Normal install routine sets the pet position to approximately 8 inches above the ground. The pet opening height may be changed to open anywhere between 8" and 30" above the ground. To change the automatic pet opening height refer to the following procedure:

- a. After completion of the normal install routine, with the door in the closed position, place the disconnect handle in the manual operated position.

Manually position the door to the desired pet opening height (between 8" and 30" above ground) and return disconnect handle to the motor operated position.

- b. Move the slide switch from the NORMAL (Unlock) position to the DOOR LOCK (Lock) position and then back to the NORMAL (Unlock) position. The opener will beep once. The pet button is now programmed to automatically open the door to this custom height.

NOTE: The opener will NOT accept programmed pet lock position if door is below 8" or higher than 30".

NOTE: Activation of the normal install routine will reset the pet position to the default 8" target height. For use of the pet button see operation section.

Multi-Door Programming:

Momentarily pressing the button programmed in the transmitter programming step activates the door. Other buttons can also be programmed to activate different doors, for multi-door installations. Each button or a combination of two buttons pressed simultaneously can be programmed to activate a different door. Only one button at a time can be programmed to activate a specific opener.

Custom Upper Limits

Disconnect door and manually move it to the desired upper limit.

NOTE: The door must be positioned more than halfway open. Reconnect door.

Press and hold the profile button for 5 seconds. The opener will beep twice, indicating the activation of the profile routine. The door will now move to the closed position. Then, the door will open to the new upper limit.

Next, the door will go down to the closed position. Once this is complete, the door limits are set and the installation is complete.

For more profile options go to page 28 and 29.

NOTE: Before performing custom upper limit, first profile must be done from closed position.

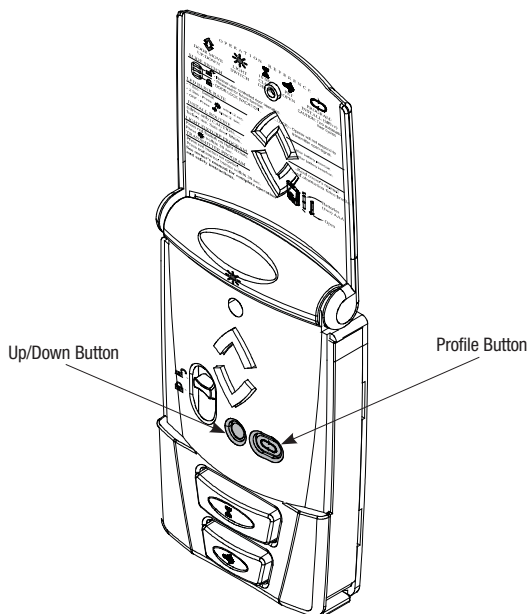
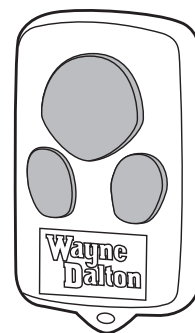
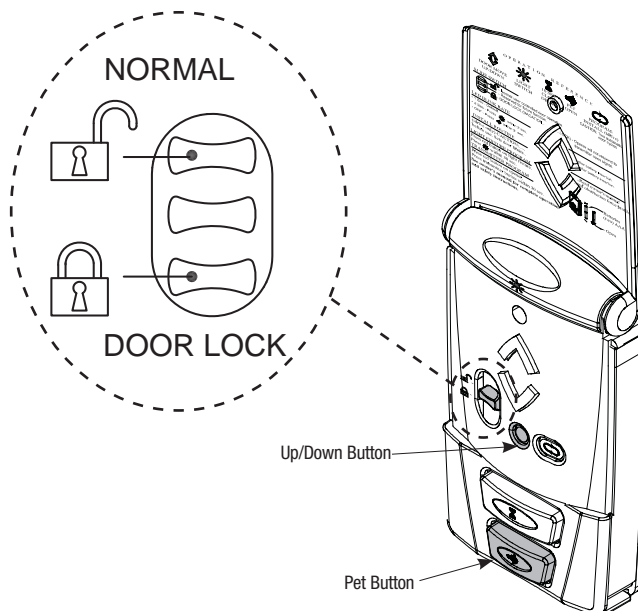



Customizing the Settings (Continued)

Erasing Remote Controls:

CAUTION: MANUALLY DISCONNECT THE DOOR FROM OPENER USING THE EMERGENCY DISCONNECT HANDLE PRIOR TO ERASING REMOTE CONTROLS.

To clear programming of all remote control devices, press and hold the opener's red program button for approximately 10 seconds. When the opener beeps 3 times, all remote controls are erased.

Multi Opener Light Control:

A single light fixture can be controlled by up to 6 openers. Follow the procedure outlined on Step 23 to program additional openers.

Erasing Light Fixtures:

To clear programming of all openers from a light fixture, press and hold the light fixture program button for approximately 10 seconds. When the light fixture lamp and LED flash 3 times, all openers are erased.

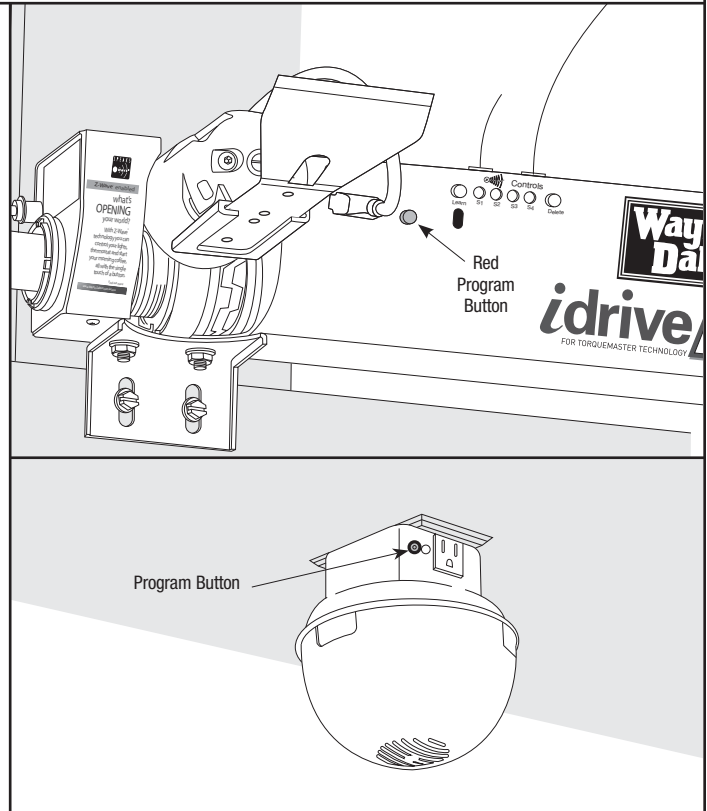

Maintenance

Monthly Maintenance:

1. Lubricate hinges and rollers of garage door.
2. Inspect the door for loose fasteners, worn or frayed counterbalance cables and the presences of legible safety labels/ tags. Have repairs made by a qualified service person. Contact customer assistance for safety labels/ tags.
3. With door fully closed, move the emergency disconnect to the manual door operated position and manually operate door. If the door feels unbalanced or binds, have a qualified service person make necessary adjustments or repairs to the door.
4. Perform the contact/obstruction tests. See Steps 28 and 29 for the contact/obstruction test instructions. If Door/Opener fails Contact/Obstruction test run profile routine Steps 24 or 25 making sure door is completely closed prior to activation. If opener still fails, have a qualified service person make adjustments/repairs or this could result in severe or fatal injury.
5. Failure of Door/Opener to respond to transmitter or wall station may be due to a weak or dead battery. Replace the battery.

Battery replacement for Wall Station:

Remove the battery cover completely (right-hand side of wall station) by disengaging the battery cover's lower clip. Install two AAA batteries into the wall station observing the polarity, (+) and (-), of both batteries. After a few seconds, the red LED will begin to blink every three seconds. If it is desired to slow the red LED blink rate refer to the wall station operation section on page 34 "Backlit LED Light". Re-install the battery cover by first inserting its top into the wall station then inserting and securing its bottom.

Note: Use only 2 AAA batteries.

Battery replacement for Transmitter:

Insert a coin in the coin slot of the transmitter and twist coin to access the dead battery. Replace the battery, being careful to match the positive (+) symbols on the circuit boards with the battery.

Note: Use (1) CR2016 or equivalent battery.

Note: Dispose of dead battery properly.



Power Connection — Permanent Wiring Option

If required by local codes, the opener can be permanently wired. Services of a licensed electrician should be obtained, to permanently wire the Unit. Disconnect electrical power at fuse/breaker box.

⚠ WARNING

TO AVOID ELECTRICAL SHOCK, DISCONNECT POWER AT FUSE/ BREAKER BOX BEFORE PROCEEDING.

- a. Using a phillips head screwdriver, remove the two screws from the right hand cover and unplug motor power cable. Remove right hand cover from the opener to expose electronics and wiring.
- b. Remove potentiometer gear. Unsnap the circuit board from the chassis stand-offs and lower the circuit board as shown.

NOTE: Do not disconnect the two ground wires (A & B) from the circuit board or the chassis.

- c. Using pliers, compress 3 snaps of the strain relief fitting inside the chassis and push fitting out of the chassis. Cut opener power cord to a length that will leave 6" inside of the junction box.

- d. Route opener power cable through the conduit. Strip 2 to 3 inches of outer jacket off power cable, insuring individual wire insulation is not nicked or cut. Strip approximately 3/4" of insulation off each individual wire. Using wire nuts, splice each conduit wire with the corresponding wire inside the opener as follows: opener black (line), opener white (neutral), and opener yellow and green (ground).

NOTE: Select 1/2" conduit fitting/ J-box that will not interfere with the opener disconnect cable fittings when disconnect is pulled.

- e. Reinstall the circuit board back into the opener chassis and snap the board back into the chassis stand-offs.

NOTE: Make sure antenna wire is routed through the chassis grommet and angled 45 degrees to right when board is installed.

- f. Confirm pot nut position* shown below.

- g. Reinstall the potentiometer gear, right hand cover, and screws.

- h. Reconnect Power

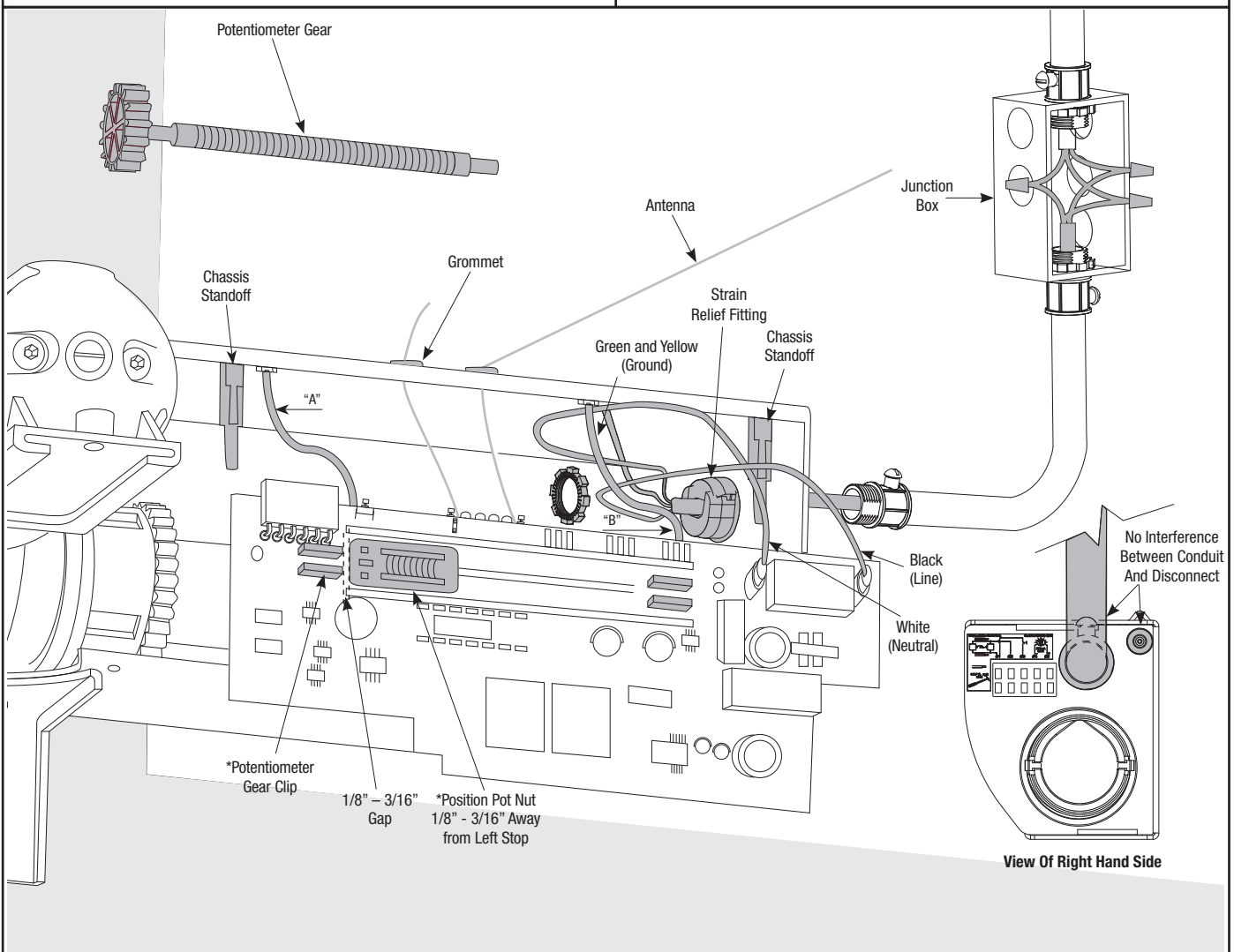



Programming Wireless Wall Station(s) or Transmitter(s) to Opener

Tools Needed:
None

⚠ WARNING

TO AVOID POSSIBLE SEVERE OR FATAL INJURY, MANUALLY DISCONNECT THE OPENER, USING THE EMERGENCY DISCONNECT HANDLE PRIOR TO PROGRAMMING REMOTE CONTROLS.

NOTE: The opener can be activated by up to six remote control devices (including Wall Station, Transmitter, and Keyless Entry Devices). If a seventh control is programmed, the first of the program controls will be overwritten and will no longer activate the opener.

- Pull the emergency disconnect handle to the manual door operated position (lower position).
- On the front cover of the opener, press and release the red program button; the opener will beep once, indicating activation of the program mode. The opener will remain in program mode for 30 seconds. If at the end of 30 seconds the opener has not learned an RF device, the opener will beep once, indicating the learn mode is no longer active.

- Press and hold the desired transmitter button or wall station light button until the opener beeps once. The transmitter or wall station is now programmed.

No beeping response from the opener during the transmitter or wall station programming indicates a programming failure. Repeat programming Steps a-c.

- Return the emergency disconnect handle to the motor operated position (upper position).

NOTE: The first transmitter command after programming will only move the door through a six inch up/down cycle. Normal door operations will occur on the second use of the transmitter or wall station.

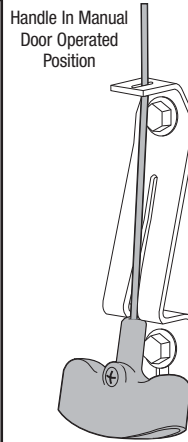

a

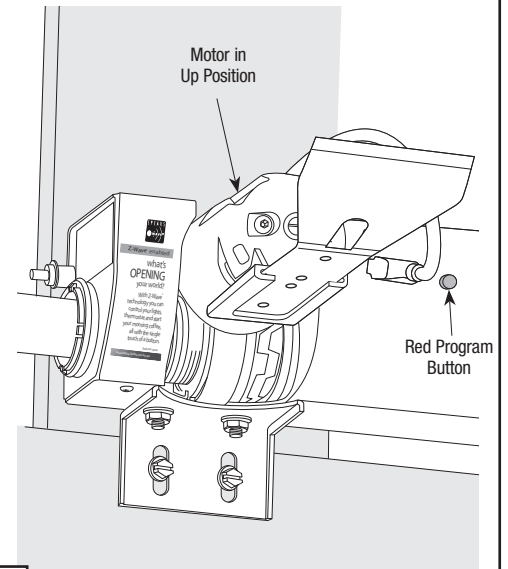

b

c

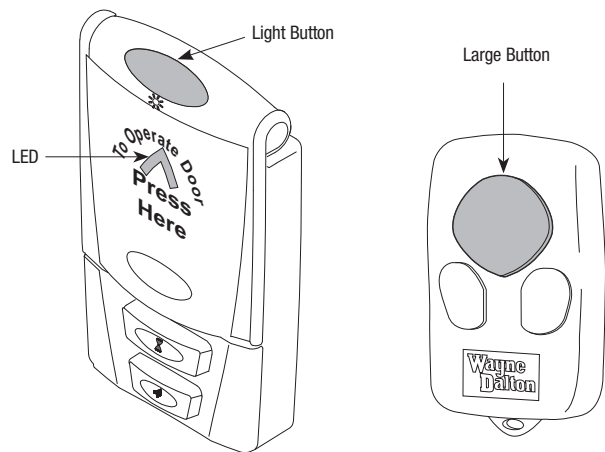

d

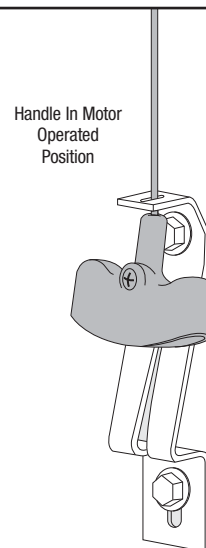



Troubleshooting

Symptom	Probable Cause	Corrective Action
Opener does not respond to the Wall Station or Transmitter.	No power to the Opener. Controls are not programmed.	Check the Opener Power Cord to outlet connection. See Activation and Programming section.
Opener works from the Wall Station but not from the Transmitter.	Transmitter is not programmed. Weak or dead Transmitter battery.	See Activation and Programming section. See Maintenance section for battery replacement.
Opener works from the Transmitter but not from the Wall Station.	Wall Station is not programmed. Weak or dead Wall Station battery.	See Activation and Programming section. See Maintenance section for battery replacement.
Door does not move and the Opener beeps two times.	The profile routine has not been performed.	Perform the profile routine Step 24 or 25.
Door does not move with a Wall Station or Transmitter command and no beeps come from the Opener.	Blown fuse or tripped circuit breaker. No power to the Opener.	Reset the circuit breaker or contact a qualified service person for fuse information. Check Power Cord connection.
Door does not move with a Wall Station or Transmitter and Opener beeps one time.	Possible loose Motor connection.	Check Motor plug connection.
Door stops or reverses, and the Opener beeps three or four times.	Obstruction encountered. Safety Sensor misalignment (if applicable). Out-of-balance condition detected.	Clear the door path. Re-align Safety Sensors Step 21. Run new Profile Routine Steps 24 or 25
Door does not close properly.	Counterbalance Cables are not on the Cable Drums properly.	Apply constant pressure to the Wall Station's Up/Down Button to close the door.
Door will not close.	Thermal delay: The door has cycled eight times in a five-minute period. Safety Sensor misalignment (if applicable). Contact obstruction test failure.	Door will operate after a one-minute waiting period. Re-align Safety Sensors Step 21. Apply constant pressure to Wall Station Up/Down Button until door is closed Repeat the profile routine Steps 24 or 25 or contact a qualified service person.
Door does not travel to the full open or full close position.	Door is out of balance. Door limits are set improperly.	Adjust the springs to correct the balance or call a qualified service person. Repeat the profile routine Steps 24 or 25.
Door is not sealing to the floor.	Bottom door limit is set too high. Outside door seal is set too tightly against the face of the door.	Disconnect the Opener and force the door to the floor. Reconnect the Opener and activate the profile routine Steps 24 or 25. Adjust weather seal position.
Motor does not pivot up fully when door is opening.	Counterbalance springs have too much tension.	Adjust the springs to correct the balance or call a qualified service person. Profile routine may have to be rerun. Steps 24 or 25.
Door is reversing at or near the floor.	Outside door seal is too tight against the face of the door. Counterbalance springs have too much tension (torsion). Vertical Track is spaced too close to the bottom door section, causing the door to bind.	Reinstall the door seal so as to be not so tight against the face of the door. Adjust Track away from the door until binding is removed. Contact a qualified service person.

Please Do Not Return This Product To The Store. Call Us Directly! Our Trained Technicians Will Answer Your Questions and/or Ship Any Parts You May Need. You can reach us Toll Free at **1-888-827-3667** for Consumer Assistance or online at **www.wayne-dalton.com**



Troubleshooting (Continued)

Symptom	Probable Cause	Corrective Action
Light fixture will not light during the door operation or by pressing the Wall Station light button.	Faulty light bulb. No power to receptacle. Opener not programmed to light.	Install new bulb (75W Max). Check circuit breakers. Program per Step 23.
Motor does not pull fully up when using the Emergency Disconnect.	Disconnect Cable has slipped inside of Handle.	Re-install Handle per instructions in Step 8.
Motor starts but the door will not move.	Opener is disconnected from the Torque Tube.	Ensure Disconnect Handle is in the Motor Operated Position. Re-install Handle per instructions in Step 8.
Motor does not pivot down. Motor pivots partially after the door closes.	Detent Pin is set too hard.	Using a Flat Tip Screwdriver, rotate the Detent Pin counter-clockwise in 1/8 turn increments until the Motor fully pivots down after the door closes see Steps 26.
Motor pivots down prematurely (before the door closes completely).	Detent Pin is set too soft.	Using a Flat Tip Screwdriver, rotate Detent Pin clockwise in 1/8 turn increments until Motor fully pivots down after door closes, and Opener immediately shuts off Steps 26.
Light Kit will work with light control but Wall Station will not move the door when Up/Down Button is pressed and the overhead light blinks three times.	Opener is in the vacation mode.	Move wall switch to the "Lock" position, wait 5 seconds return slide switch to "Normal" (Unlock) position to unlock vacation mode. Opener will emit one beep. Opener will now move the door. If not, try again. If Opener now emits two beeps when commanded then Opener needs to be profiled. See Opener profiling page 28 or 29.
Wall Station not operational.	Wall Station mounted incorrectly. Low battery.	Ensure Wall Station is mounted on a flat surface. Change battery see page 38.



Lock Arm Troubleshooting

Symptom	Probable Cause	Corrective Action
The door interferes with the Lock Arm when manually verifying clearance.	Lock Arm is set too far out. The Torque Tube is not level (Opener needs to be raised). The door top brackets and/or track configuration are not set correctly (Set top brackets higher). Motor not fully rotated up to Detent Pin engaged position.	Ensure the Lock Arm is mounted using the correct hole location stated in Step 27. Remount the Opener per Steps 4 and 5 , ensuring the Opener and Torque Tube are level prior to fastening. For new door and Opener installations, refer back to the instructions included with the door for top bracket and/or track configurations. For retro-fit installations on current doors, refer back to the section of this manual titled: Retro fit installation for iDrive, for top bracket and/or track configurations. Remount the Disconnect Handle per Step 7, ensuring proper Cable tension between the Opener and the Handle.



Lifetime Limited Warranty

i drive® for TorqueMaster® and TorqueMaster® Plus

Subject to the terms and conditions contained in this Lifetime Limited Warranty, Wayne-Dalton Corp. ("Manufacturer") warrants the opener, including electronic components (Batteries are not warranted), which is described at the top of this page, for a period of **FIVE (5) YEARS** from the date of installation against:

- (i) Any defects in material or workmanship.

The Manufacturer provides a Lifetime Limited Warranty on the motor only, against defects in material and workmanship.

After a period of **TWENTY(20) YEARS**, from time of installation, replacement of Lifetime Limited Warranty materials will be pro-rated at 50 per cent of Manufacturer's published list pricing at time of claim, and you must pay this amount.

This Limited Warranty is extended only to the person who purchased the product and continues to own the premises (where the opener is installed) as his/her primary residence ("Buyer"). This Limited Warranty does not apply to residences other than primary, or to commercial or industrial installations, or to installations on rental property (even when used by a tenant as a residence). This Limited Warranty is not transferable to any other person (even when the premises is sold), nor does it extend benefits to any other person. As a result this Limited Warranty does NOT apply to any person who purchases the product from someone other than an authorized Wayne-Dalton dealer or distributor.

The Manufacturer will not be responsible for any damage attributable to improper storage, improper installation, or any alteration of the opener or its components, abuse, damage from corrosive fumes or substances, salt spray or saltwater air, fire, Acts of God, failure to properly maintain the opener, or attempt to use the opener, its components or related products for other than its intended purpose and its customary usage. This Limited Warranty does not cover ordinary wear.

THIS LIMITED WARRANTY COVERS A CONSUMER PRODUCT AS DEFINED BY THE MAGNUSON-MOSS ACT. NO WARRANTIES, EXPRESS OR IMPLIED (INCLUDING BUT NOT LIMITED TO THE WARRANTY OF MERCHANTABILITY OR FITNESS FOR A PARTICULAR PURPOSE) WILL EXTEND BEYOND THE TIME PERIOD SET FORTH IN **UNDERScoreD BOLD FACE TYPE** IN THIS LIMITED WARRANTY, ABOVE.

- Some States do not allow limitations on how long an implied warranty lasts, so the above limitations may not apply to you.

Any claim under this Limited Warranty must be made in writing, within the applicable warranty period, to the dealer from which the product was purchased. Unless the dealer is no longer in business, a written claim to the Manufacturer will be the same as if no claim had been made at all.

At the Manufacturer's option, a service representative may inspect the product on site, or Buyer may be required to return the product to the Manufacturer at Buyer's expense. Buyer agrees to cooperate with any representative of the Manufacturer and to give such representative full access to the product with the claimed defect and full access to the location of its installation.

If the Manufacturer determines that the claim is valid under the terms of this Limited Warranty, the Manufacturer will repair or replace the defective product. The decision about the manner in which the defect will be remedied will be at the discretion of the Manufacturer, subject to applicable law. **THE REMEDY WILL COVER ONLY MATERIAL. THIS LIMITED WARRANTY DOES NOT COVER OTHER CHARGES, SUCH AS FIELD SERVICE LABOR FOR REMOVAL, INSTALLATION, SHIPPING, ETC.**

Any repairs or replacements arranged by Manufacturer will be covered by (and subject to) the terms, conditions, limitations and exceptions of this Limited Warranty; provided, however, that the installation date for the repaired or replaced product will be deemed to be the date the original product was installed, and this Limited Warranty will expire at the same time as if there had been no defect. If a claim under this Limited Warranty is resolved in a manner other than described in the immediately preceding paragraph, then neither this Limited Warranty nor any other warranty from the Manufacturer will cover the repaired or replaced portion of the product.

THE REMEDIES FOR THE BUYER DESCRIBED IN THIS LIMITED WARRANTY ARE EXCLUSIVE and take the place of any other remedy. The liability of the Manufacturer, whether in contract or tort, under warranty, product liability, or otherwise, will not go beyond the Manufacturer's obligation to repair or replace, at its option, as described above. **THE MANUFACTURER WILL NOT UNDER ANY**

CIRCUMSTANCES BE LIABLE FOR SPECIAL, INCIDENTAL, OR CONSEQUENTIAL DAMAGES, including (but not limited to) damage or loss of other property or equipment, personal injury, loss of profits or revenues, business or service interruptions, cost of capital, cost of purchase or replacement of other goods, or claims of third parties for any of the foregoing.

- Some States do not allow the exclusion or limitation of incidental or consequential damages, so the above limitation or exclusion may not apply to you.

No employee, distributor, dealer, representative, or other person has the authority to modify any term or condition contained in this Limited Warranty or to grant any other warranty on behalf of or binding on the Manufacturer, and anyone's attempt to do so will be null and void.

Buyer should be prepared to verify the date of installation to the satisfaction of the Manufacturer.

The rights and obligations of the Manufacturer and Buyer under this Limited Warranty will be governed by the laws of the State of Ohio, USA, to the extent permitted by law.

- This Limited Warranty gives you specific legal rights and you may also have other rights, which may vary from State to State.



Cut-Out Template to Aid Installation

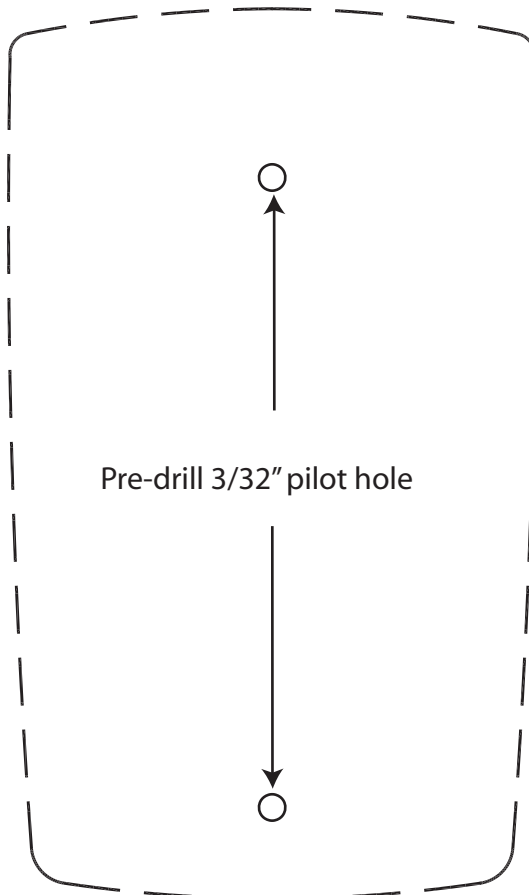

Wall Station Template

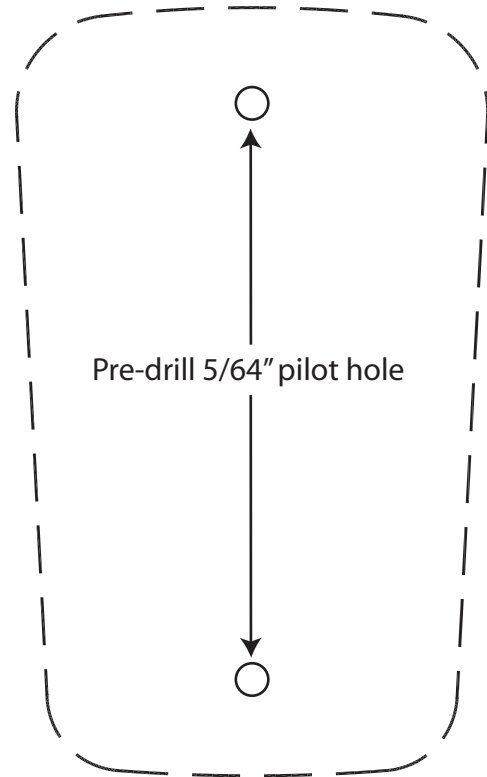

Keyless Entry Template

Please Do Not Return This Product To The Store

Call Us Directly! Our Trained Technicians Will Answer Your Questions and /or Ship Any Parts You May Need

Call Us Toll-Free:
(888) 827-3667

Thank you for your purchase

www.wayne-dalton.com

Patent Information

Models: 3790/3790-Z

Made under the following US patents and methods D413,579; D466,141; D472,568; D472,910; D473,573; D473,574; D474,215; D505,393; D517,580; CA 2,348,784; 5,929,580; 6,078,249; 6,145,570; 6,164,014; 6,253,824; 6,263,947; 6,325,134; 6,326,751; 6,326,754; 6,401,792; 6,561,255; 6,561,256; 6,568,454; 6,588,156; 6,605,910; 6,667,591; 6,739,372; 6,845,804; 6,851,465; 6,873,127; 6,880,609; 6,903,650; 7,053,571; 7,061,197; 7,075,256; 7,109,677; 7,123,128; 7,143,804; 7,173,389; 7,173,514; 7,173,516; 7,183,732; 7,190,266; 7,193,502; 7,207,142; 7,211,975; 7,246,647; 7,280,031; 7,327,107; 7,327,108; 7,327,249; 7,358,480; 7,367,160; 7,375,484; 7,375,612; 7,376,401; 7,397,342. Other US and Foreign Patents pending.

FCC and IC Statement

FCC Regulatory Information:

This device complies with Part 15 of the FCC Rules. Operation is subject to the following two conditions: (1) this device may not cause harmful interference, and (2) this device must accept any interference received, including interference that may cause undesired operation.

IC Regulatory Information:

Operation is subject to the following two conditions: (1) this device may not cause interference, and (2) this device must accept any interference, including interference that may cause undesired operation of the device.

NOTE: This equipment has been tested and found to comply with limits for a Class B digital device, pursuant to Part 15 of FCC Rules. These limits are designed to provide reasonable protection against harmful interference in a residential installation. This equipment generates, uses and can radiate radio frequency energy and, if not installed and used in accordance with these instructions, may cause harmful interference to radio communication; however, there is no guarantee that interference will not occur in a particular installation. If this equipment does cause harmful interference to radio or television reception, which can be determined by turning equipment off and on, user is encouraged to try to correct interference by one or more of the following measures: Reorient or relocate receiving antenna. Increase separation between equipment and receiver. Connect equipment into an outlet on a circuit different from that which receiver is connected. Consult your dealer or/and experienced radio/television technician for help.

WARNING: Changes or modifications to this unit not expressly approved by party responsible for compliance could void user's authority to operate this equipment.

Free Manuals Download Website

<http://myh66.com>

<http://usermanuals.us>

<http://www.somanuals.com>

<http://www.4manuals.cc>

<http://www.manual-lib.com>

<http://www.404manual.com>

<http://www.luxmanual.com>

<http://aubethermostatmanual.com>

Golf course search by state

<http://golfingnear.com>

Email search by domain

<http://emailbydomain.com>

Auto manuals search

<http://auto.somanuals.com>

TV manuals search

<http://tv.somanuals.com>