

# Walker Rider Lawnmowers

## OWNER'S MANUAL

Safety, Assembly, Operating, and Maintenance Instructions

## and ILLUSTRATED PARTS MANUAL

Model SB36 Single-Stage Snowblower

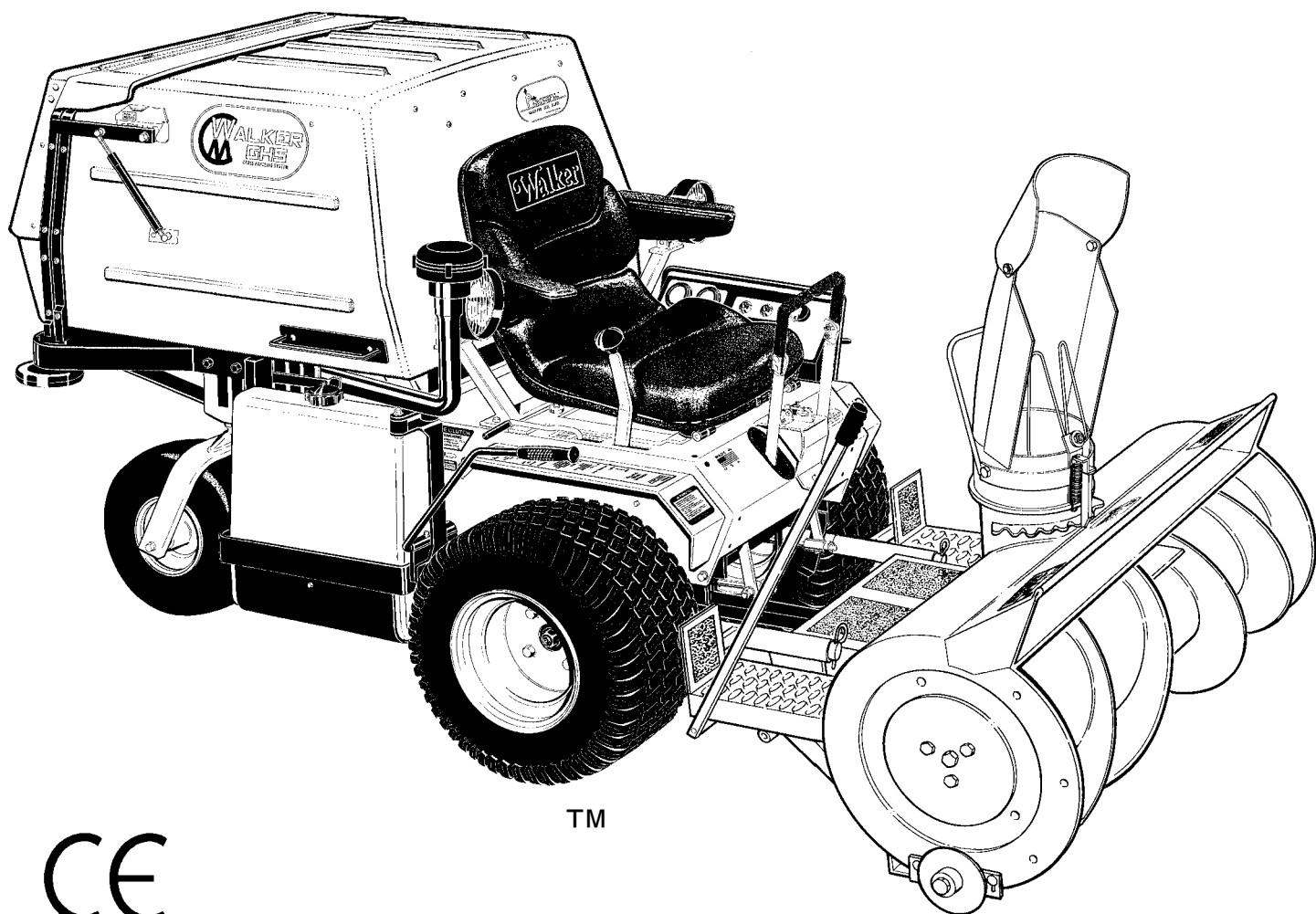

TM

CE

**Please Read and Save These Instructions**

For Safety, Read All Safety and Operation  
Instructions Prior to Operating Machine

Effective Date: 04-01-99

P/N 5600-1

Price \$5.00



## Foreword

**Thank you.** . .for purchasing a Walker snowblower. Every effort has been made to provide you with the most reliable product on the market, and we are sure you will be among our many satisfied customers. If for any reason this product does not perform to your expectations, please contact us at (970) 221-5614. Every customer is important to us. Your satisfaction is our goal.

**Please.** . .read this manual thoroughly! This manual is to be used in conjunction with the mower owner's manual and the engine manufacturer's manual for the specific engine on the mower model you are using. Before you operate your new snowblower, please read this entire manual. Some of the information is crucial for proper operation and maintenance of this product - it will help protect your investment and ensure that the snowblower performs to your satisfaction. Some of the information is important to your safety and must be read and understood to help prevent possible injury to the operator or others. If anything in this manual is confusing or hard to understand, please call our service department, at (970) 221-5614, for clarification before operating or servicing this product.

This manual covers the Model SB36 Single-Stage Snowblower.

**All shields and guards must be in place for the proper and safe operation of this snowblower.** Where they are shown removed in this manual, it is for illustration purposes only. **Do not operate this product unless all shields and guards are in place.**

Specifications given are based on the latest information available at the time this manual was produced.

Walker Mfg. Co. is continually striving to improve the design and performance of its products. We reserve the right to make changes in specifications and design without thereby incurring any obligation relative to previously manufactured products.

Sincerely,  
WALKER MANUFACTURING COMPANY

A handwritten signature in cursive script that reads "Bob Walker". The signature is written in dark ink and is positioned above the printed name.

Bob Walker, President

# Table of Contents

## Owner's Manual

<b>General Information</b> _____	1
HIGHLIGHTED INFORMATION _____	1
GLOSSARY _____	1
IDENTIFYING NUMBER LOCATIONS _____	1
SERVICING OF DRIVETRAIN GEARBOX _____	2
UNIT DESCRIPTION _____	2
<b>Specifications</b> _____	3
GROUND CLEARANCE IN RAISED POSITION _____	3
DIMENSIONS _____	3
BLOWER SPOUT _____	3
AUGER DIMENSIONS _____	3
WEIGHT _____	3
DRIVE SYSTEM _____	3
SCRAPER _____	3
TRACTOR COUNTERWEIGHT _____	3
<b>Component Identification</b> _____	4
<b>Safety Instructions</b> _____	6
BEFORE OPERATING _____	6
OPERATING _____	7
MAINTENANCE _____	8
SAFETY, CONTROL, AND INSTRUCTION DECALS _____	9
<b>Assembly Instructions</b> _____	10
SETUP AND INSTALLATION _____	10
PREOPERATING CHECKLIST _____	14
<b>Operating Instructions</b> _____	15
CONTROL IDENTIFICATION, LOCATION, AND FUNCTION _____	15
Tractor Controls _____	15
Lift Handle _____	15
Foot Trigger _____	16
Spout Position Control Handle _____	16
Deflector Position Control Handle _____	16
STARTING THE MACHINE _____	16
ENGAGING THE SNOWBLOWER _____	16
STOPPING THE MACHINE _____	17
RECOMMENDATIONS FOR SNOWBLOWING _____	18
REMOVING SNOW _____	18
Throw Snow to One Side _____	18
Throw Snow to Both Sides _____	19
CLOGGING CHECKLIST _____	19

<b>Operator's Notes</b> _____	20
-------------------------------	----

## Maintenance Instructions \_\_\_\_\_ 21

MAINTENANCE SCHEDULE CHART _____	21
LUBRICATION _____	22
Grease Fitting and Oil Point Lubrication _____	22
PTO U-Joint _____	22
Gearbox Lubrication _____	22
Drive Chain Lubrication _____	23
REPLACING/REPAIRING _____	26
Gearbox Replacement _____	26
Drive Chain _____	27
Sprockets _____	28
Drive Shaft Sprocket Replacement _____	28
Auger Sprocket Replacement _____	29
Scraper Blade _____	31
Flexible Coupling Spider _____	31
U-Joint Shear Pin _____	31
ADJUSTMENTS _____	31
Drive Chain Tension _____	31
Gauge Wheels or Skid Shoes _____	32

## Removal and Storage Instructions \_\_\_\_\_ 33

REMOVAL _____	33
END OF SEASON STORAGE _____	33

## Illustrated Parts Manual

MAIN BODY COMPONENTS _____	34
AUGER AND DRIVETRAIN COMPONENTS _____	36
KEY TO ABBREVIATIONS USED IN ILLUSTRATED PARTS LIST _____	38

<b>Warranty</b> _____	39
-----------------------	----

# General Information

## HIGHLIGHTED INFORMATION

Walker Manufacturing recommends that any service requiring special training or tools be performed by an authorized Walker Mower Dealer. There are several general practices to be aware of in the area of safety. Most accidents associated with the operation or maintenance of a Walker product are caused by disregarding basic safety precautions or specific warnings. Such accidents, in most cases, can be prevented by being aware of the dangers present.

Information of special importance has been highlighted in bold type in this manual. Refer to **Safety Instructions** for the meanings of **DANGER**, **WARNING**, **CAUTION**, **IMPORTANT**, and **NOTE**.

## GLOSSARY

There are many terms that are either unique to this equipment or that are used as acronyms. The following terms and their definitions will help while using this manual.

- **FORWARD SPEED CONTROL (FSC)** controls the maximum forward speed of the tractor; functioning as a cruise control.
- **LEFT HAND (LH)** refers to the left-hand side of the tractor when the operator is seated facing forward in the tractor seat.
- **MACHINE** consists of the snowblower installed on the tractor, functioning as a single unit.
- **POWER TAKE-OFF (PTO)** transmits engine power to run the snowblower.
- **RIGHT HAND (RH)** refers to the right-hand side of the tractor when the operator is seated facing forward in the tractor seat.
- **TRACTOR** is the prime mover, including the engine, drivetrain, operator seat, and controls to operate the snowblower.

## IDENTIFYING NUMBER LOCATIONS

The snowblower serial number is stamped on the right side of the frame between the mounting tube and the foot trigger.

Model and serial numbers are helpful when obtaining replacement parts and maintenance assistance. For ready reference, please record these numbers in the space provided.

Snowblower Model No.	_____ SB36 _____
Snowblower Serial No.	_____
Date of Purchase	_____

Fill In By Purchaser

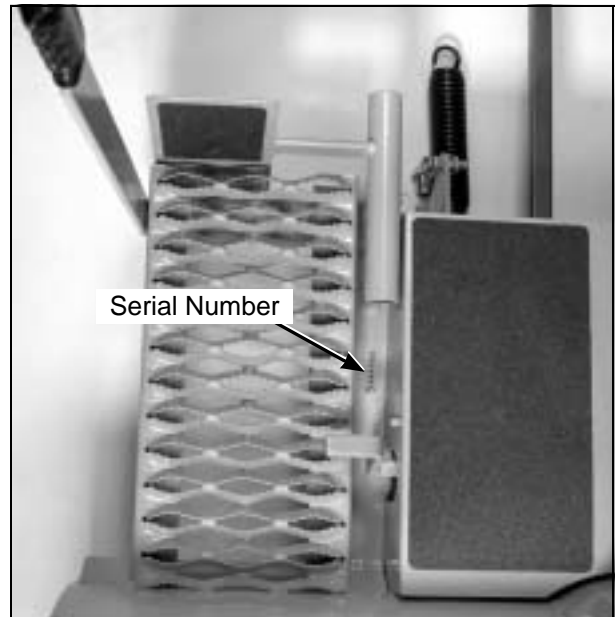

**Snowblower Serial Number Location  
(Top View)**

# General Information

## SERVICING OF DRIVETRAIN GEARBOX

Detailed servicing and repair of the gearbox used on the snowblower drivetrain is not covered in this manual. Only routine maintenance and general service instructions are provided. For the service of the gearbox during the limited warranty period, it is important to find a local, authorized servicing agent of the component manufacturer. **Any unauthorized work done on this component during the warranty period may void the warranty.** If you have any difficulty finding an authorized outlet or obtaining warranty service, please contact our Service Department for assistance:

**Walker Manufacturing Company**

5925 E. Harmony Road  
Fort Collins, CO 80528  
1-970-221-5614

A service manual is available for the gearbox from:

**Tecumseh Products Co.**

900 North Street  
Grafton, WI 53024

## UNIT DESCRIPTION

The SB36 is a 36-inch (91.4 cm), single-stage snowblower that attaches to any of the Walker tractors. The SB36 throws snow up to 20 ft (6 m). It is raised and lowered manually with a lever and a foot trigger. The blower spout is controlled with a simple position control handle. The SB36 is powered by the tractor PTO through the PTO shaft, right angle gearbox and chain final drive to auger. Tire chains and a soft cab are available as optional equipment.

# Specifications

<b>MODEL</b>	<b>SB36</b>
<b>GROUND CLEARANCE IN RAISED POSITION</b>	4-1/2 in. (11 cm)

## **DIMENSIONS**

Height	38 in. (97 cm)
Width	40-1/2 in. (103 cm)
Length (Excluding PTO Shaft)	32-3/4 in. (83 cm)
Overall Length Installed on Tractor (Model MC/MS)	89 in. (226 cm)

<b>BLOWER SPOUT</b>	6 in. (15 cm)
Spout Position Adjustment	180° (Side-to-Side)

## **AUGER DIMENSIONS**

Diameter	16 in. (41 cm)
Blade Depth	3-1/2 in. (9 cm)
Flighting Thickness	13 gauge (2 mm)

<b>WEIGHT</b>	185 lb (84 kg)
---------------	----------------

## **DRIVE SYSTEM**

Gearbox	Peerless Right Angle
Final Drive	#40 Roller Chain
Maximum Auger Speed	825 RPM
Maximum PTO Speed	2900 RPM

## **SCRAPER**

Scraper Blade	1/8 in. (3 mm) Hardened Steel Blade, Replaceable
Scraper Height	Adjustable Steel Gauge Wheels or Optional Skid Shoes

<b>TRACTOR COUNTERWEIGHT</b>	80 lb (36 kg) on Rear
------------------------------	-----------------------

**NOTE:** The manufacturer reserves the right to make changes in specifications shown herein at any time without notice or obligation.

# Component Identification

**NOTE:** Control Identification shown in **Operating Instructions** section and in **Illustrated Parts Manual**.

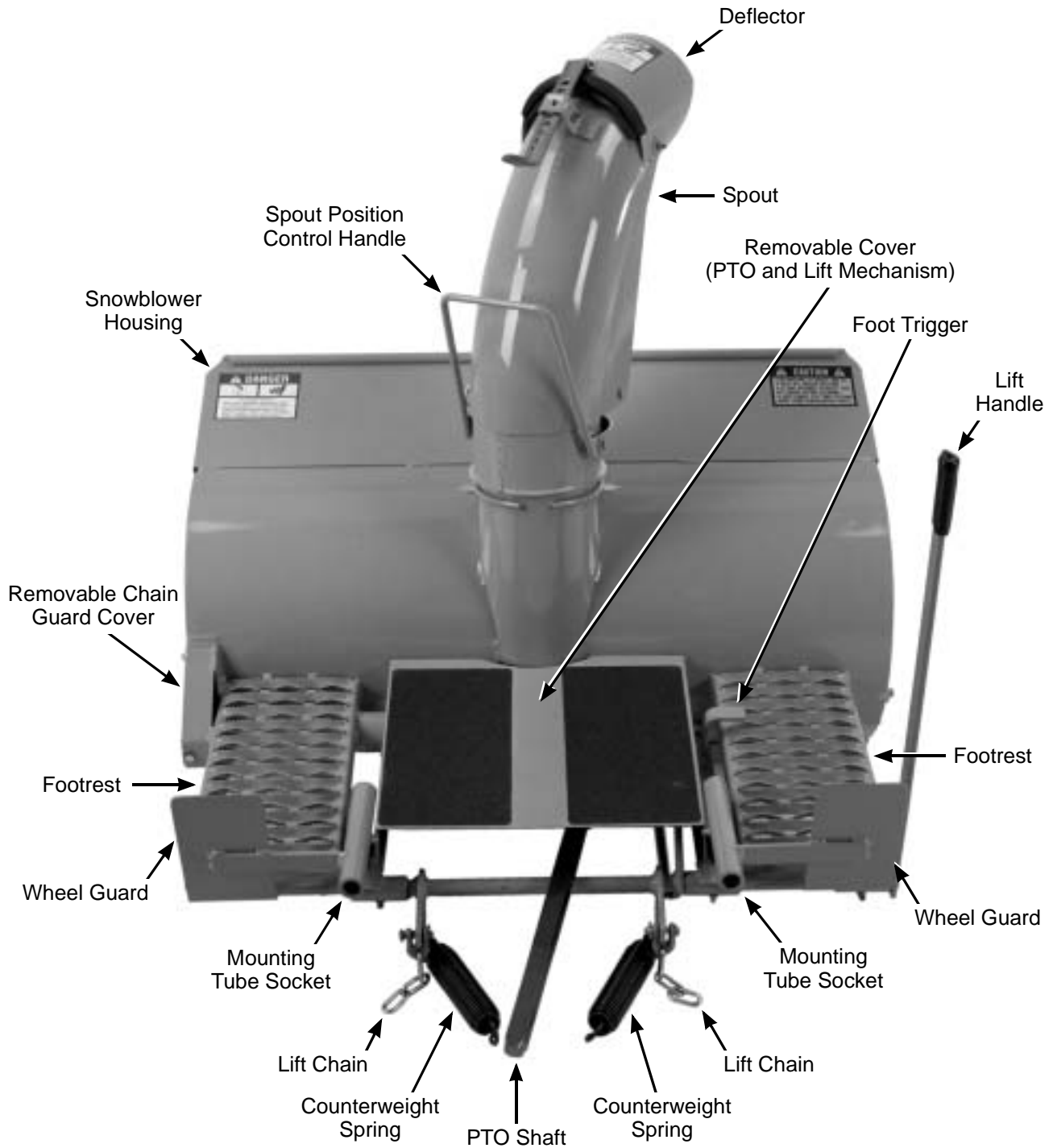

**Rear View (Not Installed)**

# Component Identification

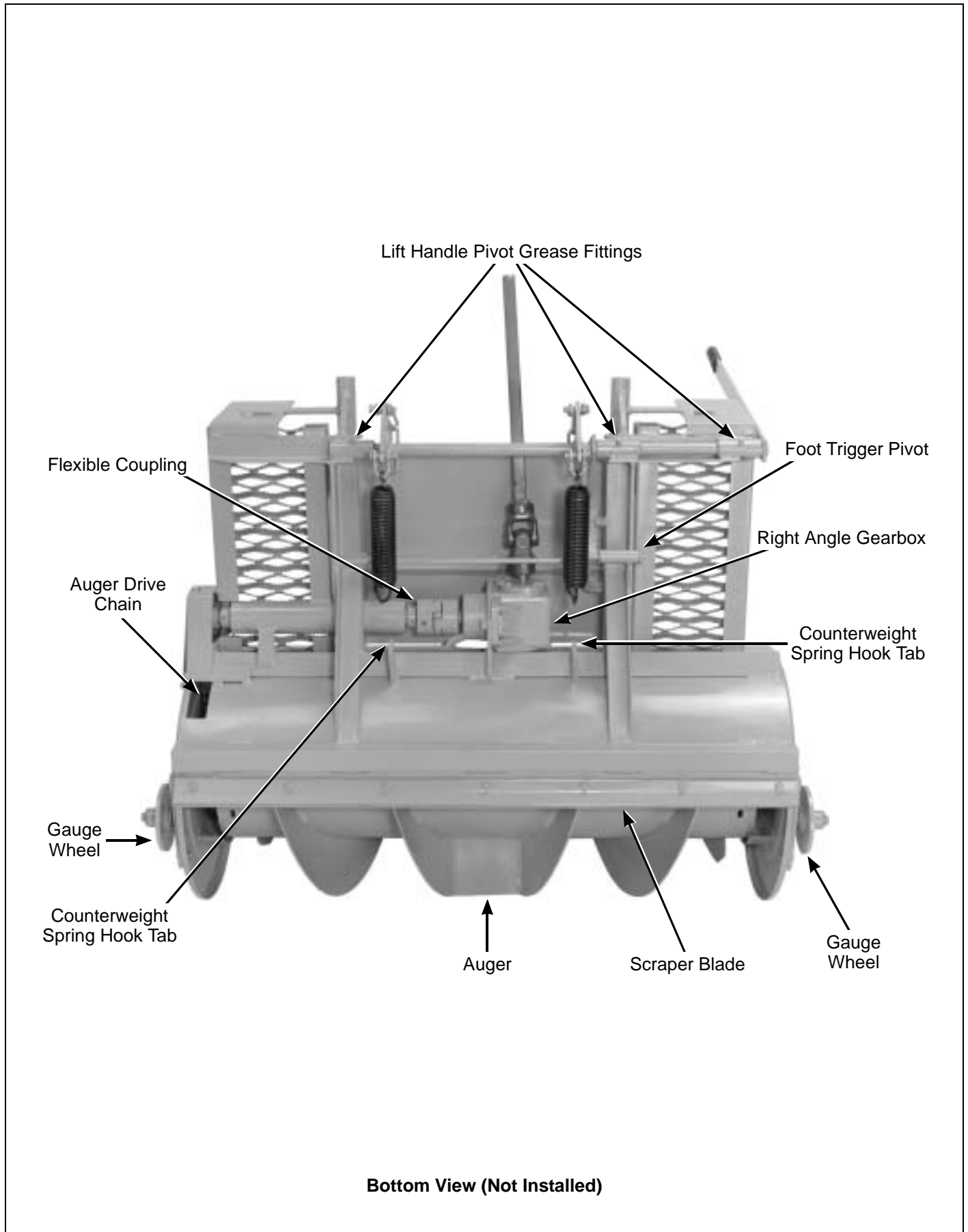



# Safety Instructions

Pay particular attention to any information labeled **DANGER**, **WARNING**, **CAUTION**, **IMPORTANT**, and **NOTE** in this manual.

When you see the Safety Alert Symbol (  ), read, understand, and follow the instructions. Failure to comply with safety instructions may result in personal injury.

The seriousness or degree of importance of each type of information is defined as follows:

## **DANGER**

An **IMMEDIATE** hazard that **WILL** result in severe personal injury or **DEATH**, if warning is ignored and proper safety precautions are not taken.

## **WARNING**

A **POTENTIAL** hazard that **COULD** result in severe personal injury or **DEATH**, if warning is ignored and proper safety precautions are not taken.

## **CAUTION**

Possible hazards or unsafe practices that **MAY** result in **MODERATE** personal injury or property damage, or machine damage, if warning is ignored and proper safety precautions are not taken.

**IMPORTANT:** Identifies mechanical information demanding special attention, since it deals with the possibility of damaging a part or parts of the machine.

**NOTE:** Identifies information worthy of special attention.

Walker Manufacturing cannot predict every potentially dangerous situation. Therefore, items labeled as such in this manual do not cover all conceivable situations. Any person using procedures, tools, or control techniques not recommended by Walker Manufacturing must take full responsibility for safety.

The Walker Tractor and Snowblower attachment have been designed with many safety features to protect the operator from personal harm or injury. However, it is necessary for the operator to use safe operating procedures at all times. **Failure to follow safety instructions contained in this manual may result in personal injury or damage to equipment or property.**

If you have any questions concerning setup, operation, maintenance, or safety, please contact your authorized Walker Mower Dealer or call Walker Manufacturing Company at (970) 221-5614.

### **BEFORE OPERATING**

1. **Read and understand the contents of this OWNER'S MANUAL before operating the snowblower.** Become thoroughly familiar with all controls and how to stop the machine and disengage the controls quickly. Replacement Owner's Manuals are available by sending the Model and Serial Number to:

**Walker Manufacturing Company**  
5925 East Harmony Road  
Fort Collins, CO 80528

2. **Never allow children to operate or give rides on the machine.** Do not allow adults to operate without proper instruction.
3. Do not allow anyone other than the operator on the machine.
4. Keep everyone, especially children and pets, a safe distance away from the area being cleaned. **Do not blow snow with bystanders in the area.**
5. Do not operate the machine wearing sneakers, tennis shoes, or similar lightweight footwear. **Wear substantial protective footwear that will improve footing on slippery surfaces.**
6. The snow can sometimes hide objects that might clog the chute, or otherwise cause damage. Clear the area of doormats, sleds, boards, wires and other debris.

# Safety Instructions

7. Do not wear loose fitting clothing that could get caught in moving parts. **Always wear adequate protective clothing** including long pants. Wearing safety glasses, safety shoes, and a helmet is advisable and required by some local ordinances and insurance regulations.
8. Prolonged exposure to loud noise can cause impairment or loss of hearing. **Operator hearing protection is recommended.** Wear a suitable hearing protective device, such as earmuffs or earplugs.
9. **Keep all protective shields and safety devices in place.** If a protective shield, safety device, or decal is damaged, unusable, or missing, repair or replace it before operating the machine.
10. **Be sure any interlock switches are functioning correctly** so the engine cannot be started unless the Forward Speed Control lever is in the **NEUTRAL** position and the PTO clutch is in the **DISENGAGED** position. Also, the engine should stop if the operator lifts off the seat with the PTO clutch in the **ENGAGED** position.
11. **Never attempt to make any adjustments while the engine is running**, except where specifically instructed to do so.
12. **Handle gasoline or diesel fuel with care.** Gasoline is highly flammable and its vapors are explosive:
  - a. Use an approved fuel container.
  - b. Never add fuel to a running engine or hot engine (allow hot engine to cool several minutes).
  - c. Keep matches, cigarettes, cigars, pipes, open flames, or sparks away from the fuel tank and fuel container.
  - d. Always fill the fuel tank outdoors using care. Fill to about one inch from the top of the tank. Use a funnel or spout to prevent spilling.
  - e. Replace the machine fuel cap and container cap securely and clean up any spilled fuel before starting the engine.

## OPERATING

**NOTE:** Refer to the **Walker Rider Lawnmowers OWNER'S MANUAL** for safety instructions for operating the tractor.

1. Operate the machine only in daylight or in good artificial light with good visibility of areas being cleaned.
2. Sit on the seat when starting the engine and operating the machine. Keep feet on footrests at all times when the tractor is moving and/or the auger is operating.
3. An inexperienced operator should **learn to steer (maneuver) the tractor with a slow engine speed before attempting any snowblowing.** Be aware that, with the front mounted snowblower configuration, the back of the machine swings to the outside during turns.
4. Remember, for an emergency stop, the forward motion of the tractor can always be stopped by pulling the Forward Speed Control (FSC) into the **NEUTRAL-PARK** position.
5. Disengage the PTO clutch and put the FSC in the **NEUTRAL-PARK** position before starting the engine (an ignition interlock switch normally prevents starting of the tractor if these controls are in the **OPERATING** position).
6. **Do not run the engine in a confined area without adequate ventilation.** Exhaust fumes are hazardous and can be deadly.
7. **Do not carry passengers** - maximum seating capacity is one (1) person.
8. Make sure the auger is clear of snow or ice before engaging the PTO clutch.
9. Be careful never to throw snow towards people or cars, and never allow anyone in front of the snowblower.
10. Watch out for hazards hidden under snow.
11. **Avoid sudden starts or stops.** Before backing the machine up, look to the rear to be sure no one is behind the machine. Watch carefully for traffic when crossing or working near roadways.
12. Disengage the PTO clutch when transporting the machine.

# Safety Instructions

13. Do not clear snow across the face of slopes. Use extreme caution when changing direction on slopes. Do not attempt to clear steep slopes.

14. **Never adjust gauge wheels or skid shoes with the engine running.** Before adjusting height or servicing, disengage the PTO clutch, stop the engine, and remove the ignition key. Wait for all movement to stop before getting off the seat.

**NOTE:** The PTO brake should normally stop drive line rotation within 5 seconds of disengaging the PTO clutch.

15. Do not operate the snowblower with the blower spout assembly removed.

16. If snowblower clogs:

a. Disengage the PTO clutch, stop the engine, and remove the ignition key before leaving the seat.

b. **LOOK** to make sure PTO shaft and auger movement has stopped before trying to unclog the snowblower.

c. Disconnect the fuel solenoid wire [diesel engines] or spark plug wire(s) [gas engines].

d. **Do not use hands or feet to unclog** the snowblower - use a stick or similar tool.

17. If the auger strikes a solid object or the machine begins to vibrate abnormally, **immediately disengage the PTO clutch, stop the engine, and wait for all moving parts to stop.** Disconnect the fuel solenoid wire [diesel engines] or the spark plug wire(s) [gas engines] to prevent accidental starting. Thoroughly inspect the snowblower and repair any damage before restarting the engine and operating the machine. Make sure auger blades are in good condition and all bolts are tight.

18. **Do not touch the engine or muffler while the engine is running** or immediately after stopping the engine. These areas may be hot enough to cause serious burns.

19. When leaving the machine unattended, disengage the PTO clutch, stop the engine, and remove the ignition key.

## MAINTENANCE

**NOTE:** Refer to the **Walker Rider Lawnmowers OWNER'S MANUAL** for proper tractor maintenance procedures.

1. **To prevent accidental starting of the engine** when servicing or adjusting the machine, remove the key from the ignition switch and disconnect the fuel solenoid wire [diesel engines] or the spark plug wire(s) [gas engines].

2. **To reduce fire hazards**, keep the engine free of grass, leaves, excessive grease, and dirt.

3. Keep all nuts, bolts, and screws tight **to ensure the machine is in a safe, working condition.**

4. **Perform only maintenance instructions described in this manual.** Unauthorized maintenance operations or machine modifications may result in unsafe operating conditions.

5. If the engine must be running to perform a maintenance adjustment, **keep hands, feet, and clothing away from moving parts. Do not wear jewelry or loose clothing.**

6. **Always use proper engine service manuals when working on the engine.** Unauthorized maintenance operations or modifications to the engine may result in unsafe operating conditions.

7. Altering the machine in any manner which adversely affects its operation, performance, durability, or use will **VOID the warranty** and may cause hazardous conditions.

8. Never attempt to disconnect any safety devices or defeat the purpose of these safety devices.

9. Do not change the engine governor settings or overspeed the engine. The governor has been factory-set for maximum-safe engine operating speed.

10. **Use genuine factory replacement parts.** Substitute parts may result in product malfunction and possible injury to the operator and/or others.

**IMPORTANT:** Keep all applicable manuals immediately accessible to anyone who may operate or service this machine.

# Safety Instructions

## SAFETY, CONTROL, AND INSTRUCTION DECALS

Safety, Control, and Instruction Decals are installed on the machine;  
If any are missing, illegible, or damaged, a replacement should be ordered and installed before putting the machine into operation. The Decal Part Number is listed below and in the Parts Manual.



**Two Places: Housing, Top LH Side (5685-1)  
Blower Spout Deflector (5685-1)**

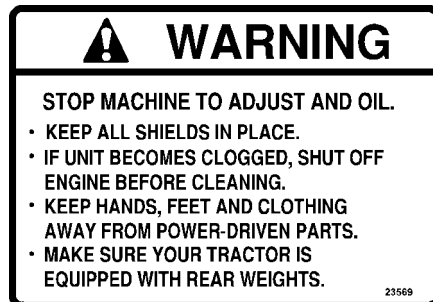

**Housing, Top RH Side (5685-2)**

# Assembly Instructions

## SETUP AND INSTALLATION

1. Remove the mower deck from the tractor if necessary. Refer to the appropriate Tractor Owner's Manual.
2. Attach each of the lift brackets to the predrilled holes on the front chassis cross bar with a 5/16-18 x 1 in. bolt and a Whiz locknut. The locknuts should be **on the front sides of the lift brackets**. Refer to **Lift Bracket Installation** illustration. The RH bracket is attached using the existing battery pan mount bolt on newer models. On earlier models, obtain the 5/16-18 x 1 in. bolt and nut locally to attach the RH bracket.

**NOTE:** Predrilled holes exist only on Walker tractors built after 1984. For earlier models, drill two 5/16 in. (8 mm) holes in the front chassis cross bar at the positions indicated in the **Lift Bracket Installation** illustration.

**IMPORTANT:** For all 1980 to 1984 tractors, **remove the battery before drilling the RH hole**. Reinstall the battery after the lift brackets have been installed. Refer to the appropriate Tractor Owner's Manual for battery removal and installation procedures.

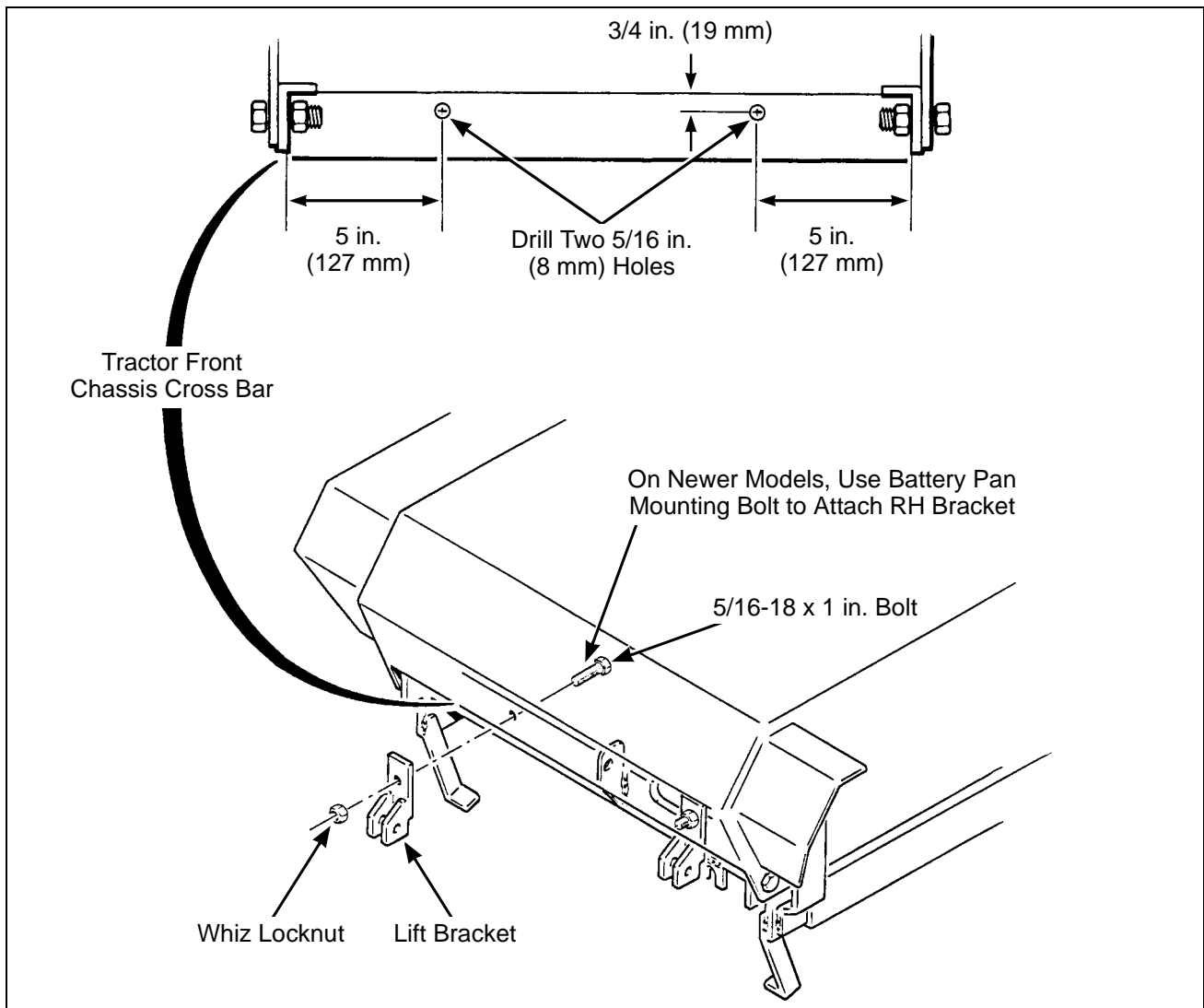

**Lift Bracket Installation**

# Assembly Instructions

3. Remove the PTO cover (between the footrests). Remove the shipping wire from the counterweight springs, place the lift handle in the **UP** (back) position, and hook the counterweight springs onto the hook tabs on the frame. The tabs are located below the right angle gearbox and drive shaft (refer to **Counterweight Spring Hook Tab Locations** photo).

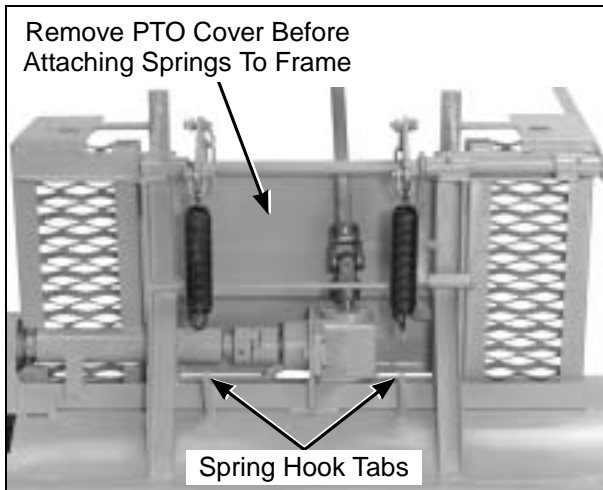

**Counterweight Spring Hook Tab Locations (bottom view)**

4. Install the spout assembly.
  - a. Remove the center bolt and nut mounting the spout discharge guard.

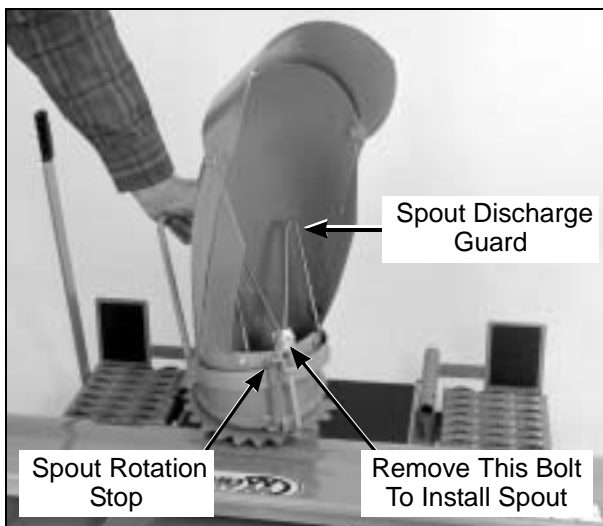

**Install Spout Assembly**

- b. Lightly grease spout mounting neck and pivot area on the housing.
  - c. Slide spout onto housing neck with spout point backwards (opposite normal direction) and then rotate to normal position.
  - d. Reinstall the bolt in the spout discharge guard along with the **spout rotation stop** as shown in the parts illustration (spout rotation stop included in hardware packet).

5. Lightly grease the tractor support arms.
6. Engage the snowblower mounting tubes on the tractor support arms.

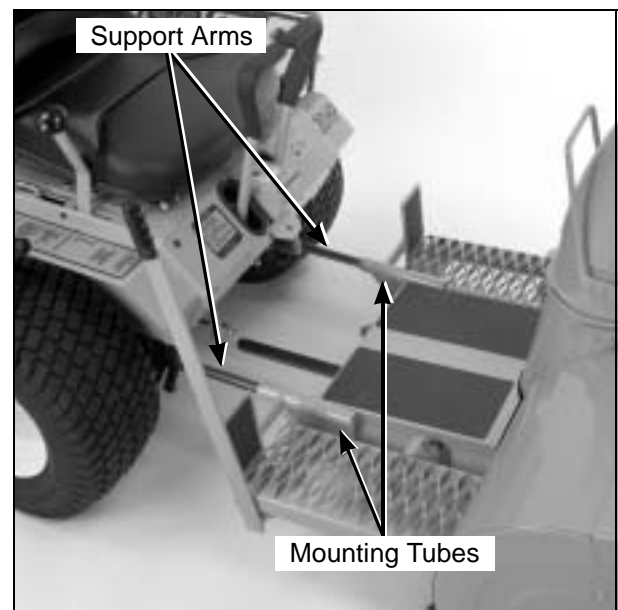

**Engage Snowblower Mounting Tubes with Tractor Support Arms**

7. Slide the snowblower onto the tractor support arms and connect the snowblower PTO shaft to the tractor with the PTO quick coupler as follows:

**NOTE:** Model MS and earlier Model MC do not have the PTO quick coupler. Use sliding joint to connect tractor to snowblower PTO.

- a. Place the pilot end of the snowblower PTO shaft into the socket of the PTO quick coupler and rotate the PTO shaft until it is aligned correctly with the socket in the PTO quick coupler, then slide together. Use arrows on the shaft and tube for correct alignment.

# Assembly Instructions

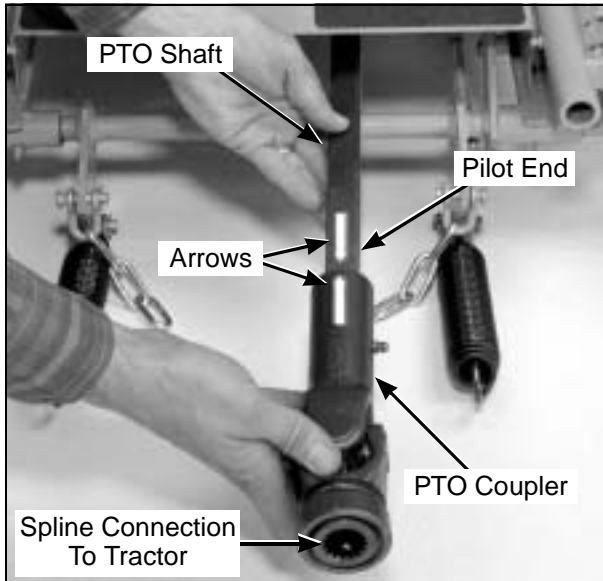

**Align PTO Shaft and PTO Coupler (shown before engaging snowblower mounting tubes with tractor support arms)**

- b. Slide snowblower assembly onto tractor. Reaching under the tractor, pull the ring back on the PTO quick coupler, slide the coupler onto the tractor spline shaft, and release the coupler ring.

**IMPORTANT:** To prevent damage to the machine, make sure the PTO quick coupler is securely locked on the tractor, with the locking balls fully seated in the groove and the ring in the full forward position (refer to the **Coupler Ring "Locked" Position** photo). After installation, pull on the shaft to check for security.

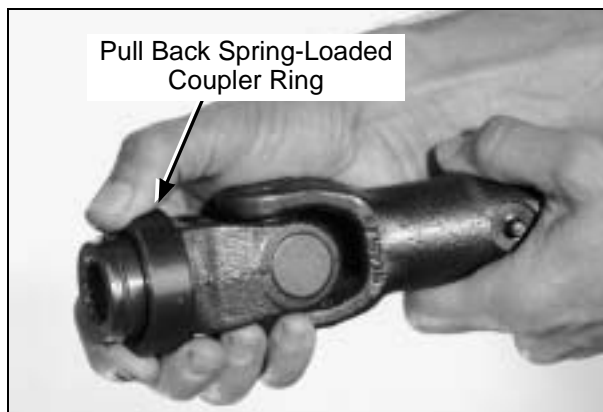

**Installing PTO Quick Coupler**



**Coupler Ring "Locked" Position**

8. Insert the hitch pins in the ends of the tractor support arms.
  9. Pull the lift handle back, press the foot trigger, and push the snowblower lift handle forward against the spring pressure into the **DOWN** (forward) position. Attach each of the lift chains to the lift brackets with a 5/16-18 x 1-1/4 in. bolt and an ESNA nut.
- NOTE:** Use a bungee cord or strap to secure lift handle in forward position while connecting lift chains to tractor.
10. Reinstall the PTO cover.

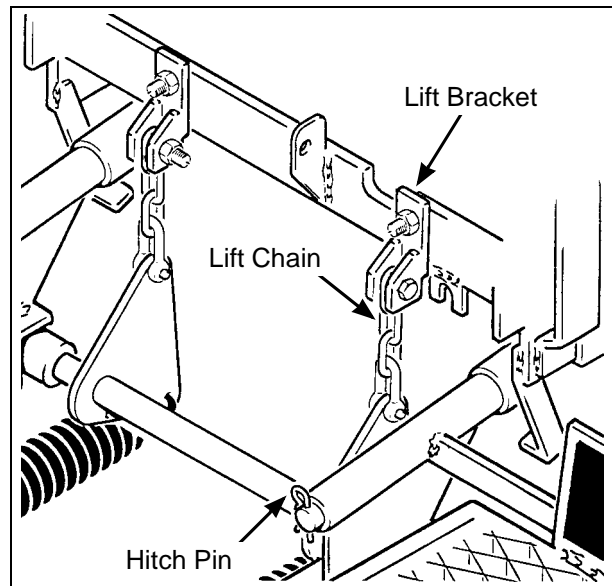

**Attach Lift Chains to Lift Brackets**

# Assembly Instructions

11. Pull the lift handle back to raise the snowblower to the **UP** position.



**Snowblower in UP (Raised) Position**

12. Pull the lift handle back, press the foot trigger, and **hold on to the lift handle while letting it move forward** to lower the snowblower to the **DOWN** position.



## **CAUTION**

**DO NOT** release the lift handle before releasing the foot trigger or before the snowblower has reached the **DOWN** position.



**Snowblower in DOWN (Lowered) Position**

13. Raise and lower the snowblower a few times to check the operation and make sure it moves smoothly. If not, grease the lift handle pivot grease fittings located on the three tubes that support the lift handle pivot. Refer to **LUBRICATION** of *Lift Handle Pivot* in **Maintenance Instructions**.

14. Adjust the gauge wheels or skid shoes. Refer to **ADJUSTMENTS** of *Gauge Wheels or Skid Shoes* in **Maintenance Instructions**.

15. To install the optional tire chains:

- Remove the tractor wheels.
- Attach the tire chains to the wheels.
- Place the wheel spacer plates on the lug bolts. The wheel spacer plates provide clearance for the chains between the tires and the tractor body.
- Place the wheels back on the tractor.
- Reinstall and tighten the lug bolts.

16. For GHS (Grass Handling System) equipped Walker tractors, install a blower intake cover in the blower intake tube. The cover "unloads" the blower and seals the intake to effectively eliminate power loss and noise when the blower is not being used.

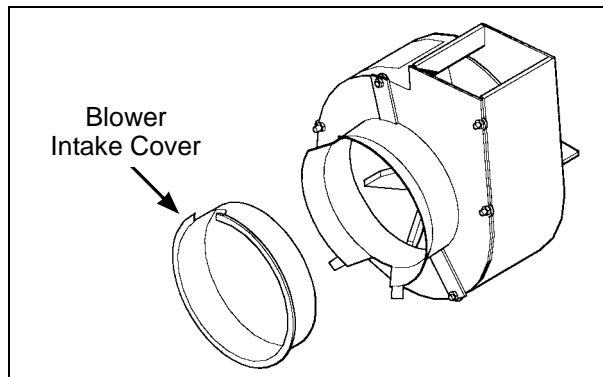

**GHS Blower Intake Cover**

17. For stability of the tractor when transporting with the snowblower raised position, approximately 80 lb (36 kg) of counterweight should be installed on the tail of the tractor. Optional tail weights for the various tractor models are available from your Walker dealer or a sandbag or similar weight may be used.



# Assembly Instructions

## PREOPERATING CHECKLIST

Before operating the snowblower for the first time, and as a routine before daily operations, it is important to make sure the snowblower is properly prepared and ready for operation. The following is a list of items to be checked. (For a snowblower with frequent operation, some of these items will not need to be checked every day, but the operator should be aware of the condition of each.)

### CHECK TRACTOR PREOPERATING CHECKLIST

Refer to the appropriate Tractor Owner's Manual.

### CHECK AUGER

- Make sure the auger is clear of snow and/or ice.
- Make sure the auger is free to rotate.
- Check that the auger flighting and paddle blades are in good condition and not bent.

### CHECK GEARBOX

Refer to **LUBRICATION** of **Gearbox** in **Maintenance Instructions**.

### CHECK DRIVE CHAIN

- Refer to **ADJUSTMENTS** of **Drive Chain** in **Maintenance Instructions**.
- Refer to **LUBRICATION** of **Drive Chain** in **Maintenance Instructions**.

### CHECK LIFT HANDLE AND FOOT TRIGGER OPERATION

Raise and lower the snowblower to make sure the lift handle and foot trigger operate properly.

### CHECK BLOWER SPOUT

- Make sure the blower spout is not clogged with snow and/or ice.
- Pull back on the spout position control handle and rotate the blower spout. The blower spout should rotate freely and should lock in place when the spout position control handle is released.
- Use the deflector position control handle and raise and lower the deflector. The deflector should move freely.

### CHECK GAUGE WHEEL OR SKID SHOE ADJUSTMENT

Refer to **ADJUSTMENTS** of **Gauge Wheels or Skid Shoes** in **Maintenance Instructions**.

### CHECK OPTIONAL TIRE CHAINS

Tire chains should always be used when operating the machine in icy conditions. If the tractor is equipped with the optional tire chains, make sure the chains are in good condition and are installed properly.

### CHECK TRACTOR TAILWEIGHT

Make sure 80 lb (36 kg) weight has been installed on rear of tractor.

# Operating Instructions

## CONTROL IDENTIFICATION, LOCATION, AND FUNCTION

### **WARNING**

Before operating the snowblower, become familiar with the location and function of all operator controls. Knowing the location, function, and operation of these controls is important for safe and efficient operation of the snowblower.

## Tractor Controls

Refer to the appropriate Tractor Owner's Manual for complete information about tractor operating controls.

## Lift Handle

The lift handle is located to the right of the operator at the back of the snowblower right footrest. The lift handle is used to raise and lower the snowblower. Moving the lift handle **forward lowers** the snowblower; moving it **backward raises** the snowblower.

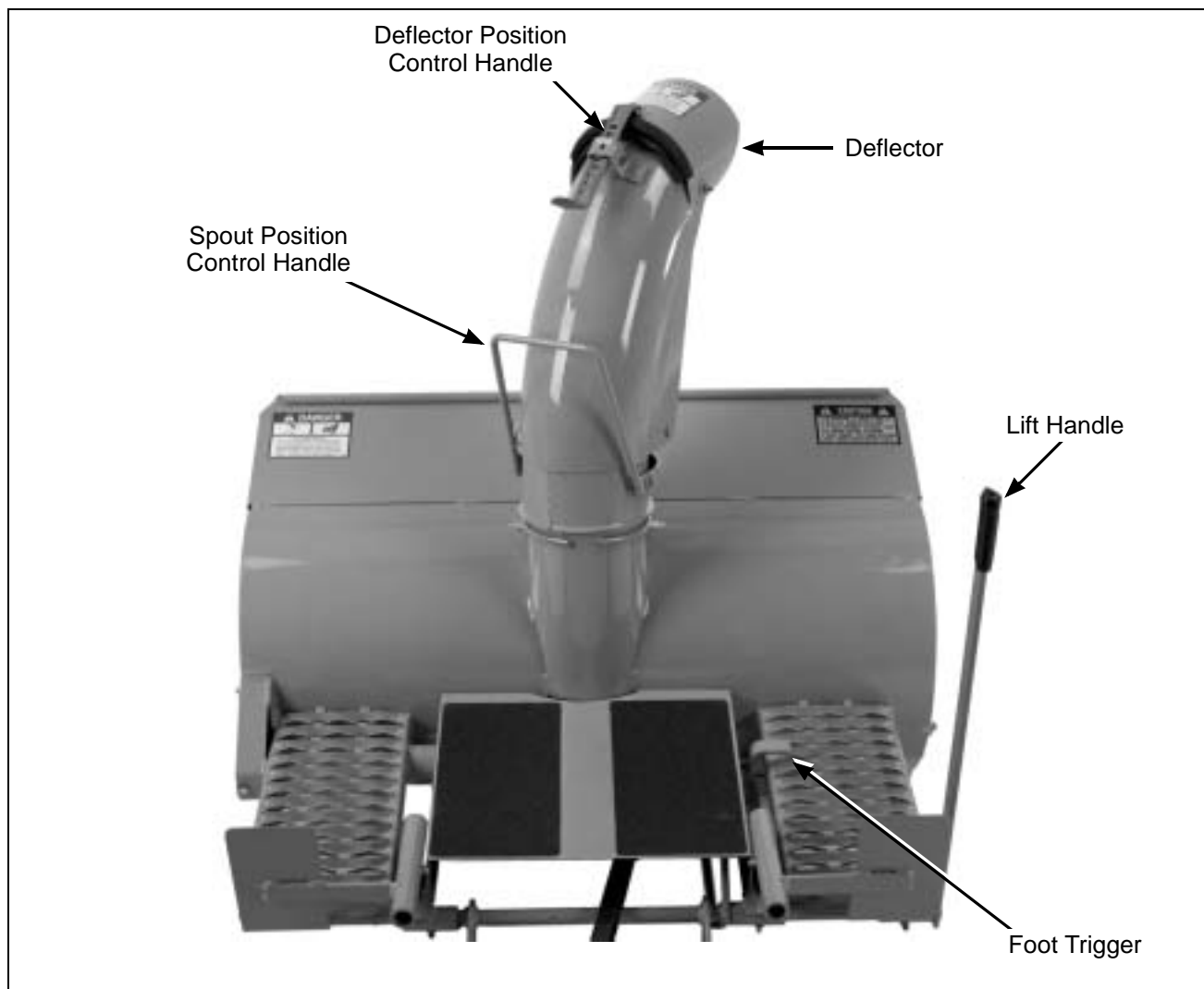

**Snowblower Operating Controls**

# Operating Instructions

## Foot Trigger

The foot trigger is located on the right footrest. The foot trigger and lift handle are used together to lower the snowblower. Pull the lift handle back, press the foot trigger, and **hold on to the lift handle while letting it move forward** to lower the snowblower.

**IMPORTANT:** To avoid the snowblower dropping down with force, **DO NOT release the lift handle while depressing the foot trigger or before the snowblower has reached the DOWN position.**

## Spout Position Control Handle

The spout position control handle is located on the back of the blower spout. The control handle is used to position the blower spout so snow is thrown in the intended direction. Pull back on the control handle and rotate the blower spout to the chosen position. Release the control handle to lock the blower spout into position.

## Deflector Position Control Handle

The deflector position control handle is located on the back of the blower spout and deflector. The control handle, which slides through a spring-loaded bracket, is used to position the deflector and control the angle and distance snow is thrown. The spring-loaded bracket holds the control handle and deflector in position.

Sliding the control handle **down raises** the deflector and throws snow a **higher, longer distance**; sliding the control handle **up lowers** the deflector and throws snow a **lower, shorter distance**.

**NOTE:** If the deflector cannot be moved, loosen the bolts that fasten it to the blower spout.

## STARTING THE MACHINE



**ALWAYS disengage the PTO clutch and put the FSC in the NEUTRAL-PARK position before starting the engine.**

Refer to the appropriate Tractor Owner's Manual for tractor starting and operating procedures.

**NOTE:** For cold weather operation, follow the proper operating procedures in the appropriate Tractor Owner's Manual. Allow sufficient time for the tractor engine to warm up before engaging the snowblower.

## ENGAGING THE SNOWBLOWER



**Before operating the snowblower, read and understand all Safety Instructions and Operating Instructions.**

1. Set the engine throttle at about 1/3 speed. **DO NOT attempt to engage the PTO clutch at high engine speeds.** This will drastically shorten drive belt life. Use only **moderate engine speed** when engaging the PTO clutch.
2. Pull the PTO clutch lever **SLOWLY** to engage the snowblower.

**NOTE:** For cold weather operation, allow sufficient time for the snowblower components (i.e., gearbox oil) to warm up before beginning to blow snow.



**A safety interlock switch (seat switch) will cause the engine to stop if the PTO clutch is engaged and the operator is not in the seat. The function of this switch should be checked by the operator raising off the seat and engaging the PTO clutch; the engine should stop. If the switch is not working, it should be repaired or replaced before operating the snowblower. DO NOT disconnect the safety switches; they are for the operator's protection.**

**IMPORTANT:** **DO NOT** engage the PTO clutch when transporting the machine. **DO NOT engage the PTO clutch with the PTO shaft disconnected** (the snowblower removed from the tractor).

# Operating Instructions

## CAUTION

If the auger strikes a solid object or the machine begins to vibrate abnormally, immediately disengage the PTO clutch, stop the engine, and wait for all moving parts to stop. Disconnect the fuel solenoid wire [diesel engines] or the spark plug wire(s) [gasoline engines] to prevent accidental starting. Thoroughly inspect the snowblower and repair any damage before restarting the engine and operating the machine. Make sure auger blades are in good condition and all bolts are tight.



PTO Clutch Engaged (Model MD Shown)



PTO Clutch Disengaged (Model MD Shown)

## STOPPING THE MACHINE

1. Slow the engine to idle; put the throttle in the **IDLE** position.
2. Pull the steering levers to the **NEUTRAL** position and then move the FSC lever backward to the **NEUTRAL-PARK** position.
3. Disengage the PTO clutch.

**IMPORTANT: DO NOT** disengage the PTO clutch with high engine speed (above 1/2 throttle) since the brake action on the PTO drive will cause premature wear of the brake band.

## WARNING

A brake stops the auger from freewheeling within five (5) seconds after disengaging the PTO clutch. If the brake system malfunctions and the auger does not stop within five (5) seconds, the brake should be adjusted or repaired before operating the snowblower. Refer to the appropriate Tractor Owner's Manual for adjustment procedures.

4. Turn the ignition switch **OFF**.

## WARNING

Remove the key from the ignition switch when leaving the machine unattended. This will prevent children and inexperienced operators from starting the engine.

5. Engage the parking brake.

**IMPORTANT:** The hydrostatic transmissions lock to prevent the machine from rolling freely with the engine stopped. However, if the machine is parked on a slope, it is necessary to **ENGAGE** the parking **BRAKE** to prevent the machine from creeping. This is due to a small amount of slippage in the hydrostatic transmissions, especially when transmission fluid is warm.

# Operating Instructions

## RECOMMENDATIONS FOR SNOWBLOWING

**IMPORTANT:** Operate the engine at **full speed** when snowblowing, to allow the engine to produce full horsepower and to increase efficiency of the engine cooling system.

- When operating on a slope, **reduce speed and use caution** to start, stop, and maneuver. Avoid sharp turns or sudden changes in direction.
- When blowing through deep snow drifts, let the snowblower work its way through the drifts. For best results, raise the snowblower and remove a top layer of snow, then pass through the area a second time to remove the remaining snow.
- When snowblowing, operate the engine at or near **full throttle** for the best snowblowing action. The engine is **designed to be operated at full speed**.
- Use optional tire chains or optional all-terrain tires to improve traction.
- Disengage the PTO clutch to stop the snowblower when driving the machine but not blowing snow.
- Avoid damage to property and extra snowblowing work by **carefully choosing the direction** to move the snow. Orient the blower away from people and property due to the possibility of thrown objects.
- To momentarily increase traction in case the drive wheels are slipping, use the lift handle to raise the snowblower slightly and transfer extra weight on the drive wheels.

## REMOVING SNOW



**DANGER**

**DO NOT** blow snow with bystanders in the area (especially children or pets).

A definite operating pattern is required to thoroughly clean snow from an area. Each pattern described below clears all the snow in one pass (of the pattern) and prevents throwing snow in unwanted places.

**IMPORTANT: DO NOT** use the snowblower as a dozer blade to push snow. Let the snowblower work its way through deep snow. If the tractor is driven forward into snow **too fast, the snowblower may become overloaded and clog.**

## Throw Snow to One Side

Use the following pattern where snow can be thrown only to one side. Start **on the side farthest from where the snow will be thrown**. At the end of the first pass, **rotate the blower spout 180 degrees for the return pass**. At the end of each following pass, rotate the spout 180 degrees to keep throwing snow in the same direction.

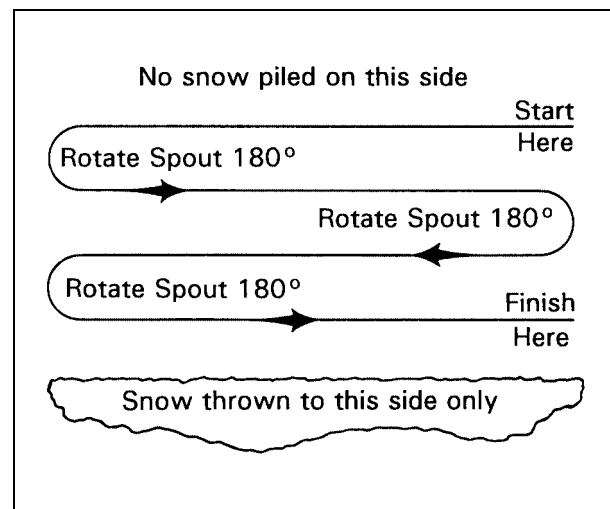

## Throw Snow to One Side

## Throw Snow to Both Sides

Use the following pattern where snow can be thrown to both sides. Start **in the middle with the blower spout directed to either the right or left**. Drive from one end to the other in an **outward spiral, without changing the position of the blower spout** to throw snow to both sides.

# Operating Instructions

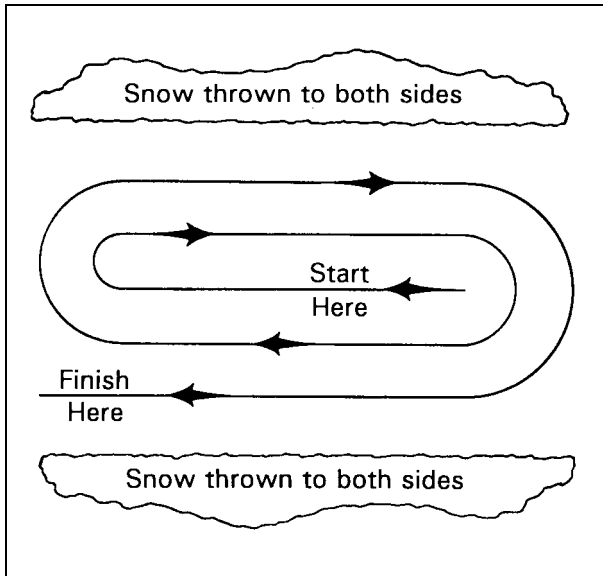

**Throw Snow to Both Sides**

## CLOGGING CHECKLIST

In case of clogging, the snow throwing action will decrease and finally stop. When this occurs, disengage the PTO clutch, stop the engine, disconnect the fuel solenoid wire [diesel engines] or spark plug wire(s) [gasoline engines], and remove the ignition key. **Make sure all movement has stopped before attempting to unclog.**

### **DANGER**

**DO NOT** attempt to unclog the snowblower or make any adjustments with the tractor engine running. Disengage the PTO clutch, stop the engine, and remove the ignition key.

### **DANGER**

**NEVER** place hands in the blower spout. **DO NOT** use hands or feet to unclog the snowblower. Use a short stick or similar tool to remove any clogged material.

The following list of items should be checked if a pattern of clogging begins to develop. All of these items are capable of causing clogging.

- Check that the inside of the snowblower housing is **clean and free of snow and/or ice buildup**.
- Check that the auger is in good condition and not bent, both the auger flighting and the center paddles.
- Check the inside of the blower spout for **smoothness and freedom of obstruction**.

Remember, anything that restricts airflow or material flow along the entire path from the auger to the blower spout can cause clogging.

# Operator's Notes

A large, empty rectangular box with a thin black border, intended for the operator to write notes. It occupies the majority of the page's vertical space.

# Maintenance Instructions



## CAUTION

Maintenance procedures requiring special training or tools should be performed by a trained technician.

### MAINTENANCE SCHEDULE CHART - RECOMMENDED SERVICE INTERVALS - SB36 SNOWBLOWER

Service Item	Daily	25 Hours	Yearly	Reference Page
Check Auger Condition	X			14
Check Lift Handle and Foot Trigger Function	X			14
Check Spout Position Control Handle	X			16
Check Deflector Position Control Handle	X			16
Check Gauge Wheel or Skid Shoe	X			32
Check Scraper Blade	X			31
Check Tire Chains (Optional)	X			14
Check/Adjust Chain Drive		X		27
Lubricate Grease Fittings and Oil Points		X		22
Lubricate Drive Chain		X		23
Check PTO Gearbox Oil Seals		X		22
Check Flexible Coupling		X		31
Repaint Components/Parts			X	33

**Refer to the appropriate Tractor Owner's Manual for complete information about tractor Maintenance Items**



## LUBRICATION

### **WARNING**

**DO NOT** attempt to lubricate the machine with the tractor engine running. Disengage the PTO clutch, shut off the machine, and remove the ignition key.

Proper lubrication is an important maintenance procedure. It reduces wear and makes the machine quieter and easier to operate.

### Grease Fitting and Oil Point Lubrication

Lubricate the grease fittings and oil points **after every 25 hours** of operation. Use SAE general purpose lithium or molybdenum base grease for grease fittings and light machine oil (SAE 10) to lubricate oil points. **Lubricate the locations shown in the Snowblower Lubrication Points illustration.**

### PTO U-Joint

Lubricate the grease fitting for the PTO U-joint **every 8 hours** with SAE general purpose lithium or molybdenum base grease.

The PTO U-joint is accessed by removing the gearbox cover. Two (2) bolts (one on each side) fasten the gearbox cover to mounting tabs on the snowblower frame (refer to **Snowblower with Gearbox Cover Removed** photo).

### Gearbox Lubrication

The gearbox is permanently lubricated (oil filled) and sealed requiring no scheduled lubrication. However, the gearbox oil seal(s) should be checked **every 25 hours** for indication of an oil leak. If an oil leak is noted, replace the oil seal and relubricate the gearbox as follows:

1. Remove the gearbox following the procedure described in **Gearbox Replacement** in **REPLACING/REPAIRING**.

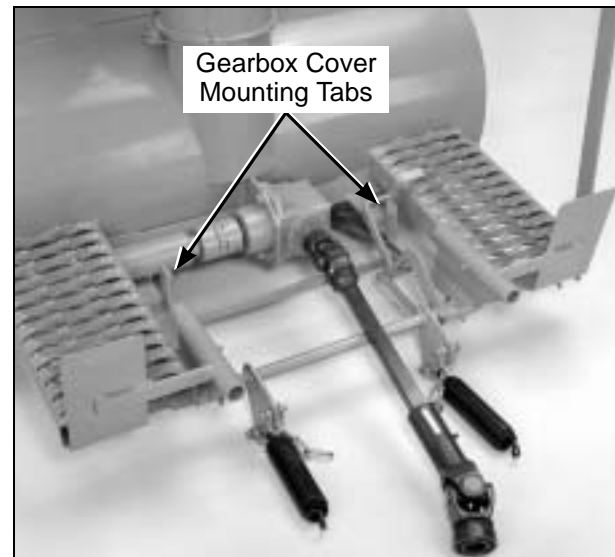

**Snowblower with Gearbox Cover Removed**

2. Clean the area around the gearbox cover plate to prevent contaminants from entering the gearcase.
3. Remove the screws securing the cover plate on the gearbox.
4. Check the level of lubricant in the gearbox. If the lubricant is low, add SAE E.P. (Extreme Pressure) 90W oil until the oil level is up to (submerges) the horizontal shaft in the gearbox (shaft parallel to cover plate).

**NOTE:** In case the gearbox is completely drained of oil, approximately 5 fl. oz. (15 cl) of oil is required to refill the gearbox.

**IMPORTANT: DO NOT** overfill the gearbox. The gearbox assembly is not vented, and overfilling with oil will cause excessive pressure and result in oil leaks.

5. Check the condition of the cover gasket and replace if worn or damaged. Reinstall gearbox cover plate; torque screws to 24 in-lb (2.7 N-m).
6. Reinstall the gearbox cover by reversing the removal procedures.

## Drive Chain Lubrication

Lubricate the drive chain **every 25 hours**. A light penetrating oil or special purpose chain oil is recommended. Lubricate the drive chain as follows:

1. Remove the three (3) screws fastening the removable chain guard cover to the snowblower housing and remove the cover.

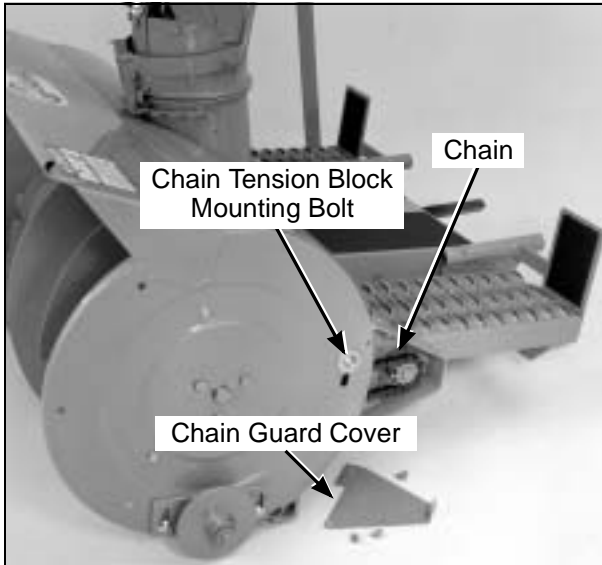

### Remove Chain Guard Cover

2. Apply oil to the drive chain.
3. Adjust the chain if necessary. Refer to **ADJUSTMENTS** of **Drive Chain** in this section.
4. Reinstall chain guard cover by reversing the removal procedures.

Ident No.	Location	Lubrication Type	No. Places	Ident No.	Location	Lubrication Type	No. Places
1	Spout Deflector Pivot	Oil	2				
2	Spout Position Control Handle Pivot	Oil	2				
3	Foot Trigger Latch (Grease Slide Area)	Grease	1				
4	Mounting Tube Sockets	Grease	2				
5	Lift Handle Pivot	Grease	3				
6	Spout Deflector Slide Area	Grease	1				
7	Counterweight Spring and Lift Chain Clevis Pins	Oil	4				
8	Universal Joint Shaft Assembly	Grease*	1				
9	Foot Trigger Pivot	Oil	1				
10	Right Angle Gearbox	Oil**	1				
11	Gauge Wheel Axle (If equipped)	Grease	2				
12	Drive Chain	Oil	1				

<p>* Grease every eight (8) hours.</p> <p>** Gearboxes are permanently lubricated and sealed requiring no scheduled lubrication. Oil level should be checked only when an oil leak is noted. Refer to <b>Gearbox Lubrication</b> in this section.</p> <p><b>NOTE:</b> Tractor Lubrication Points are not shown here. For Tractor Lubrication Points, Refer to the appropriate Tractor <b>OWNER'S MANUAL</b> or <b>ILLUSTRATED PARTS MANUAL</b>.</p>
---

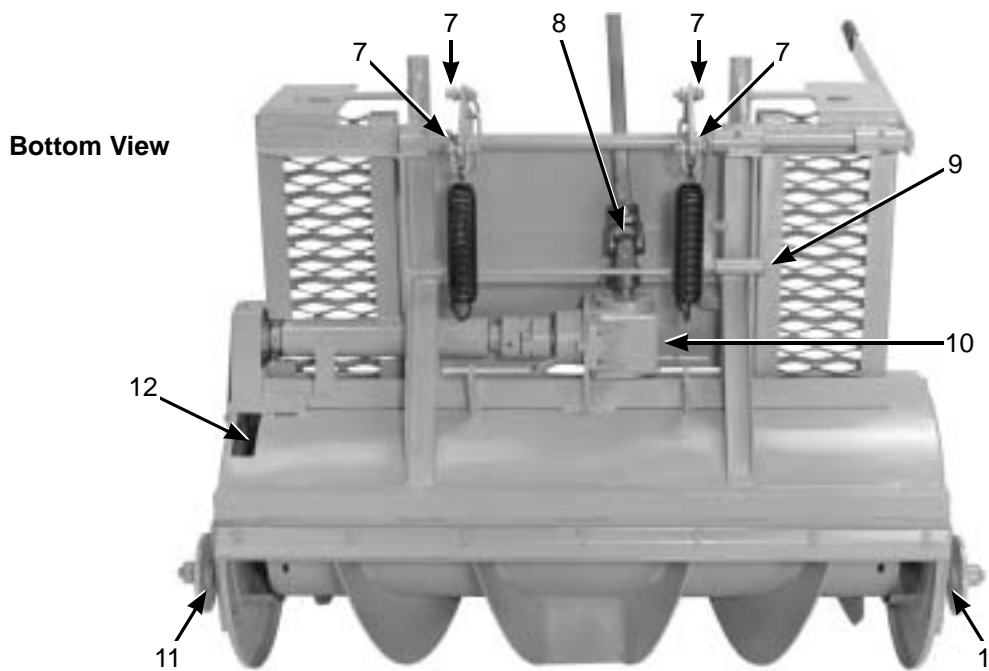
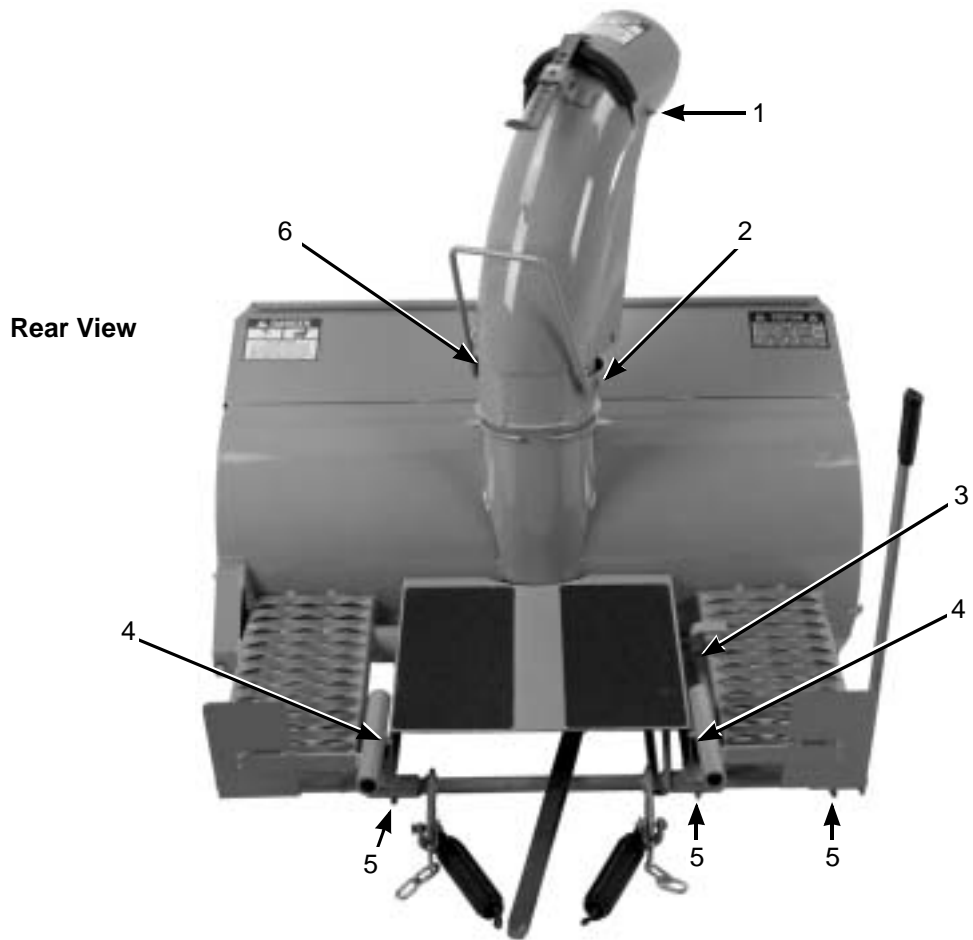

Snowblower Lubrication Points

## REPLACING/REPAIRING

### **WARNING**

To prevent accidental engine starting when replacing parts or repairing the machine, remove the key from the ignition switch and disconnect the fuel solenoid wire [diesel engines] or the spark plug wire(s) [gasoline engines].

### **CAUTION**

ALWAYS use genuine factory replacement parts. Substitute parts CAN result in product malfunction and possible injury to the operator and/or others.

## Gearbox Replacement

Remove and replace the gearbox as follows:

1. Remove the gearbox cover. Two (2) bolts (one on each side) fasten the cover to mounting tabs on the frame.
2. Loosen the set screw fastening the PTO U-joint to the gearbox shaft and slide the PTO shaft off the gearbox shaft.
3. Remove the two (2) bolts, oblong washers, and Keps nuts that fasten the gearbox to the snowblower frame.
4. Remove the gearbox from the snowblower frame.

**NOTE:** The flexible coupling spider will be loose; be sure to keep track of it. A good way to do this is to tape it in place on the flexible coupling half that is attached to the drive shaft.

5. Replace the gearbox by reversing the removal procedures.

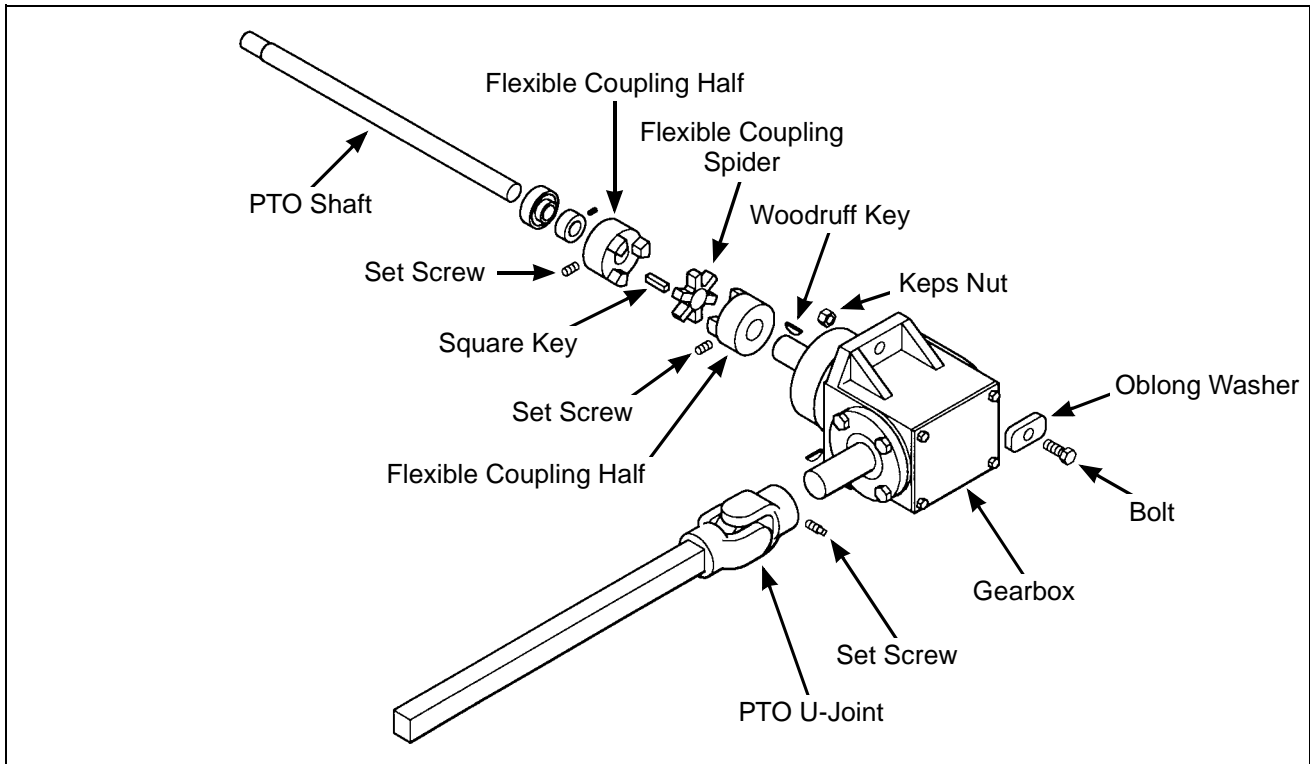

**Replace Gearbox**

### Drive Chain

The drive chain should be replaced if, when adjusted properly, it can be pulled away from the front of the auger sprocket **more than 1/2 of the height of a tooth on the sprocket**. Running the snowblower with a worn chain **increases wear on the sprockets**.

1. Remove the chain guard cover and the LH auger guard. Refer to **LUBRICATION of Drive Chain** in this section for removing chain guard cover.
2. Loosen the chain tension block mounting nut and bolt. Position the chain tension block so the chain has as much slack as possible. Tighten the chain tension block mounting nut and bolt slightly to hold the chain tension block in this position.

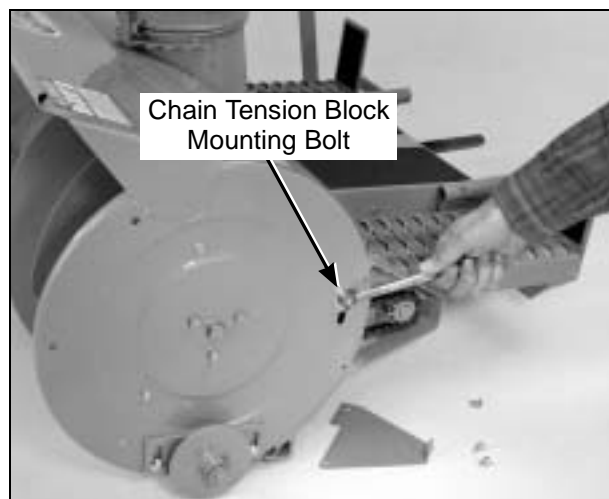

**Loosen Chain Tension**

3. Turn the auger until the master link for the chain is accessible.
4. Remove the master link from the chain and remove the chain from the sprockets.

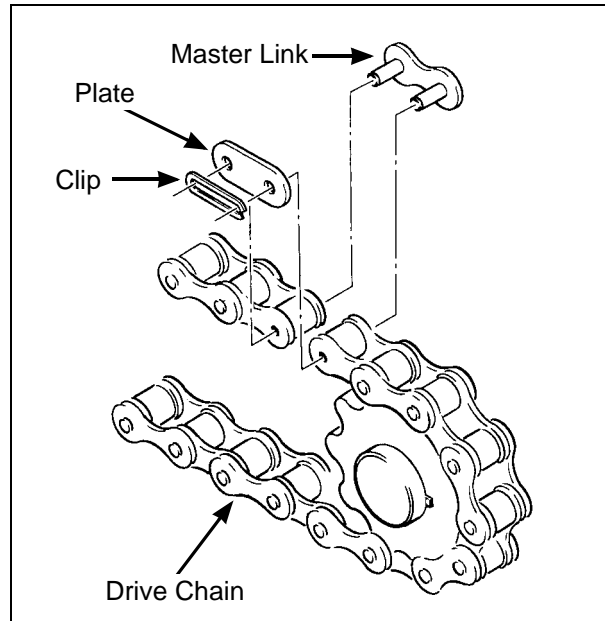

**Remove Master Link**

5. Place the new chain on the sprockets and install the master link. Be sure to install the clip on the master link properly. The **closed end of the clip** should point in the **direction of chain travel**.

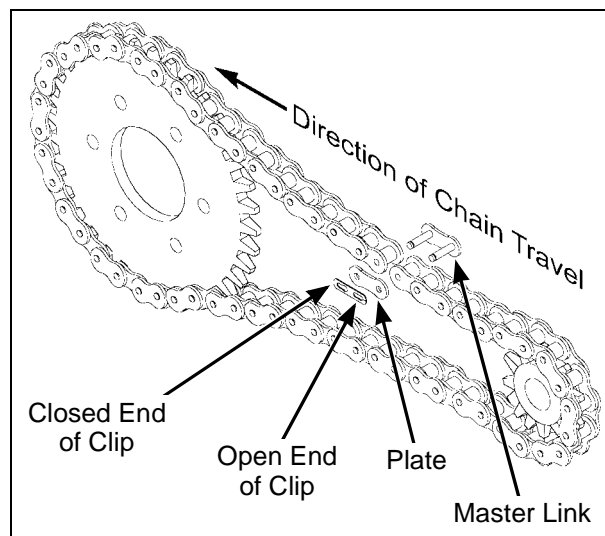

**Proper Master Link Clip Installation**

6. Adjust the chain. Refer to **ADJUSTMENTS of Drive Chain** in this section.
7. Reinstall the auger guard and the chain guard by reversing the removal procedures.

### Sprockets

A sprocket should be replaced **when the teeth become asymmetric** (when the front side of a tooth is a different shape than the back side of the tooth).

**NOTE:** Generally; a small sprocket wears faster than a large sprocket.

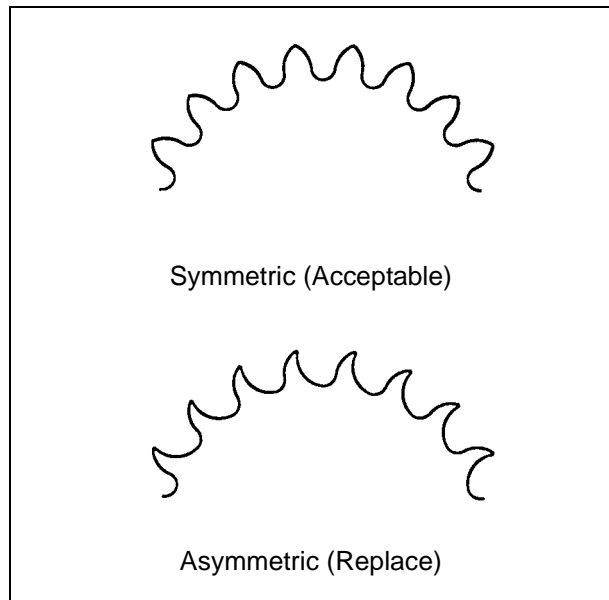

### Sprocket Wear

#### Drive Shaft Sprocket Replacement

1. Remove the chain guard cover, auger guard, and drive chain. Refer to **REPLACING/REPAIRING of Drive Chain** in this section.
2. Loosen the set screw that fastens the sprocket to the drive shaft.
3. Slide the sprocket off the drive shaft. Use a puller if necessary.
4. If necessary, clean the end of the drive shaft with an emery cloth or a wire brush.
5. Place the Woodruff key in the keyway on the drive shaft.
6. Align the slot in the new sprocket with the Woodruff key and slide the sprocket onto the drive shaft. Make sure the Woodruff key is in place between the driveshaft and sprocket.

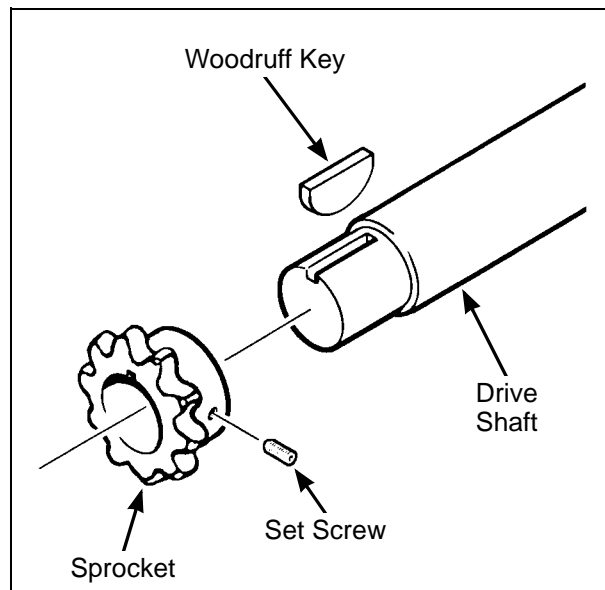

### Remove and Replace Sprocket

7. Position the sprocket on the drive shaft so it is aligned with the auger sprocket. To check alignment, look at the drive shaft sprocket, over the top of the auger sprocket, from the front of the snowblower.

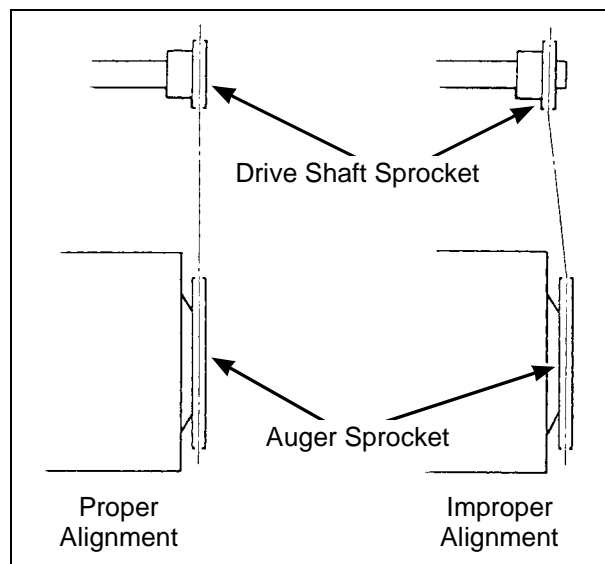

### Align Sprockets

8. When the sprockets are aligned properly, tighten the set screw in the drive shaft sprocket.
9. Reinstall and adjust the drive chain by reversing the removal procedures. Refer to **ADJUSTMENTS of Drive Chain** in this section.
10. Recheck the sprocket alignment with the chain installed.

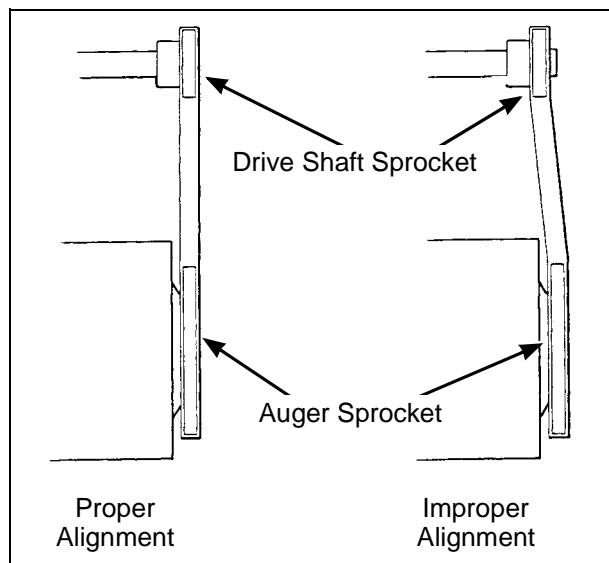

### Check Sprocket Alignment with Chain Installed

11. Lubricate the drive chain. Refer to **LUBRICATION of Drive Chain** in this section.
12. Reinstall the auger guard and chain guard by reversing the removal procedures.

### Auger Sprocket Replacement

1. Remove the chain guard cover, both auger guards, and the drive chain. Refer to **REPLACING/REPAIRING of Drive Chain** in this section.
2. Place blocks under the ends of the auger to support it when the bolts are removed from the ends of the auger shaft.
3. Remove the three (3) bolts that fasten the auger shaft key plate to the drive chain side of the snowblower housing.
4. Remove the two (2) bolts that fasten the auger shaft at each side of the snowblower housing.

5. Remove the auger from the snowblower housing. There is a spacer washer on each end of the auger shaft.
6. Remove the six (6) bolts that fasten the sprocket to the auger and remove the sprocket.
7. Install the new sprocket.
8. Reinstall and tighten the sprocket bolts.
9. Make sure the spacer washers are **on the ends of the auger shaft**.
10. Place the auger back in the snowblower housing.
11. Reinstall the bolts in both ends of the snowblower housing and auger shaft, but **do not tighten**.
12. Slide the auger shaft key plate into position on the end of the auger shaft between the spacer washer and the snowblower housing.
13. Rotate the auger shaft as necessary to align the auger shaft key plate with the three (3) mounting bolt holes.
14. Reinstall and tighten the three (3) mounting bolts for the auger shaft key plate.
15. Make sure that **both spacer washers are on the auger shaft** - not between the end of the auger shaft and the snowblower housing.
16. Retighten the bolts on both sides of the snowblower housing and auger shaft.
17. Reinstall and adjust the drive chain by reversing the removal procedures. Refer to **ADJUSTMENTS of Drive Chain** in this section.
18. Check sprocket alignment after the drive chain is installed. If the sprockets are not aligned:
  - a. Loosen the set screw in the drive shaft sprocket.
  - b. Align the drive shaft sprocket with the auger sprocket.
  - c. Tighten the set screw in the drive shaft sprocket.



19. Lubricate the drive chain. Refer to **LUBRICATION of Drive Chain** in this section.

20. Reinstall the auger guards and the chain guard cover by reversing the removal procedures.

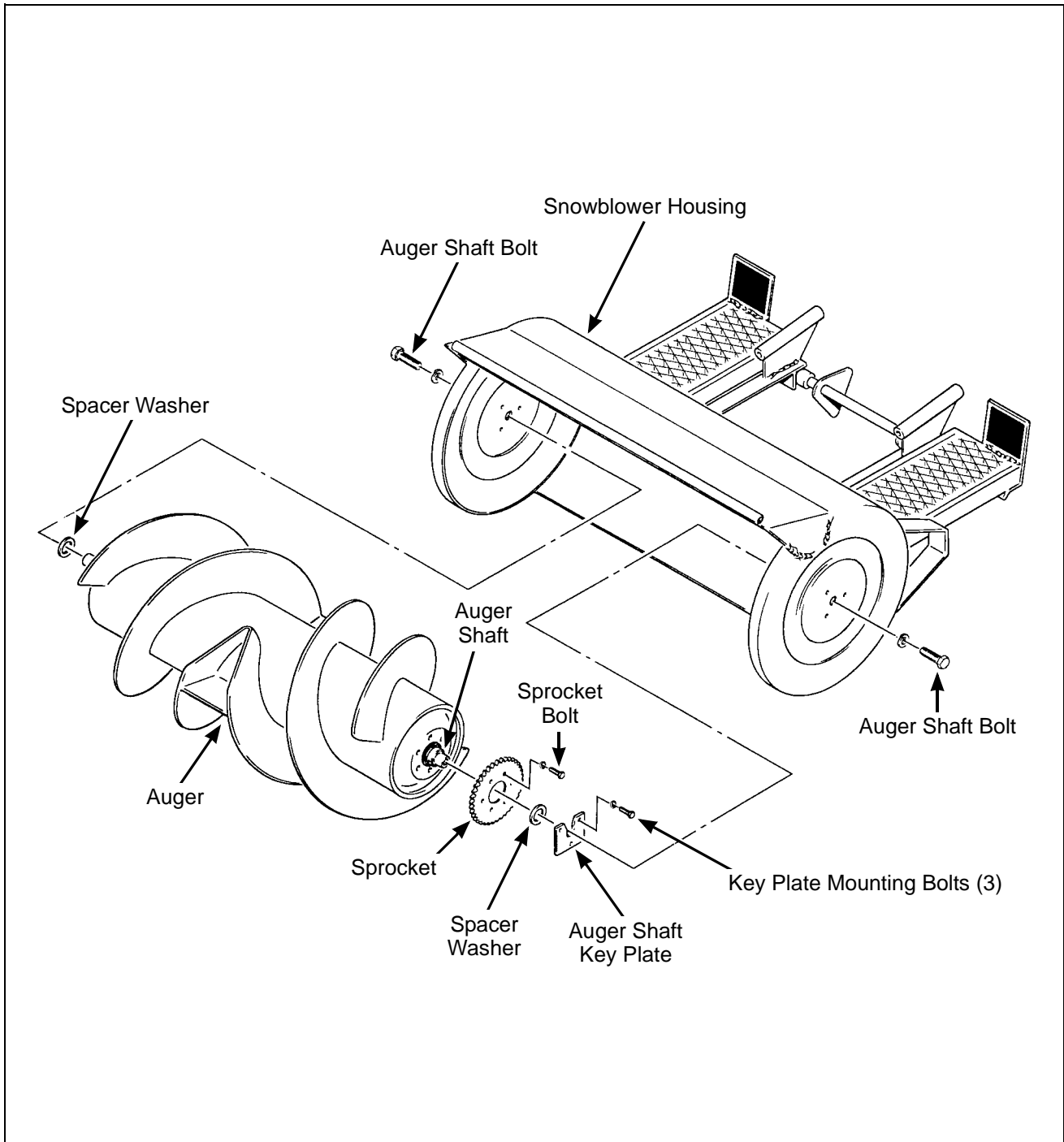

**Auger Components**

### Scraper Blade

Inspect the scraper blade for wear or damage **before each use**. The blade is hardened and if the gauge wheels (or skid shoes) are properly adjusted, the blade should give a reasonable amount of service before replacement. The blade should be replaced **before** it has worn down to the point where the blade mount on the housing is dragging and wearing.

**IMPORTANT:** Continued operation with a worn out scraper blade and/or improperly adjusted gauge wheels will result in severe damage to the lower portion of the snowblower housing.

The scraper blade is replaced by removing seven (7) 1/4-20 x 3/4 carriage bolts and nuts.

### Flexible Coupling Spider

Inspect the flexible coupling spider after **every 25 hours** of operation. If the elastomeric media shows signs of **wear, cracking or deterioration**, the spider should be replaced. Refer to **Gearbox Replacement** in this section for removing and replacing the spider.

### U-Joint Shear Pin (After S/N 99-1042)

In case of sudden stoppage of the auger, the PTO U-joint connection to the gearbox has a shear pin to provide **shock load protection** to the drivetrain. When the PTO pin has sheared, use the following procedure to replace it:

1. Remove the gearbox cover. Two (2) bolts (one on each side) fasten the cover.
2. Rotate U-joint on shaft to align the shear pin hole with the hole (and shear pin fragment) in the shaft. Use a punch to drive the remaining portion of the old shear pin out.
3. Install new shear pin and secure with cotter pin.

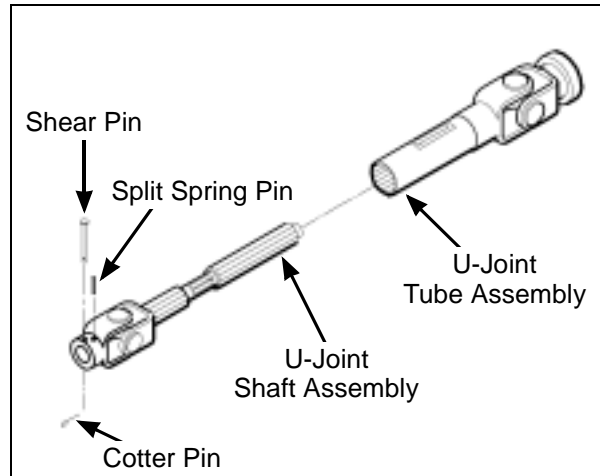

**PTO Shear Pin**

**IMPORTANT:** Use only Walker P/N 8067-10 shear pins for replacement to provide proper shock protection -- these pins are hardened to shear under a specific amount of load.

4. Reinstall the gearbox cover.

Before operating the blower after the shear pin has been replaced, inspect the auger flighting and paddle blades for damage. Also inspect the gearbox and chain drive for any damage. Make sure the auger turns smoothly and freely before resuming operation.

### ADJUSTMENTS

#### **WARNING**

**DO NOT attempt to make any adjustments with the tractor engine running. Disengage the PTO clutch, stop the engine, and remove the ignition key. Wait for all movement to stop before getting off the seat.**

### Drive Chain Tension

The drive chain should have 1/4 to 1/2 in. (6 to 13 mm) of slack at midspan. Remove the chain guard cover to check slack. Adjust the drive chain as follows:

1. Loosen the chain tension block mounting nut and bolt.

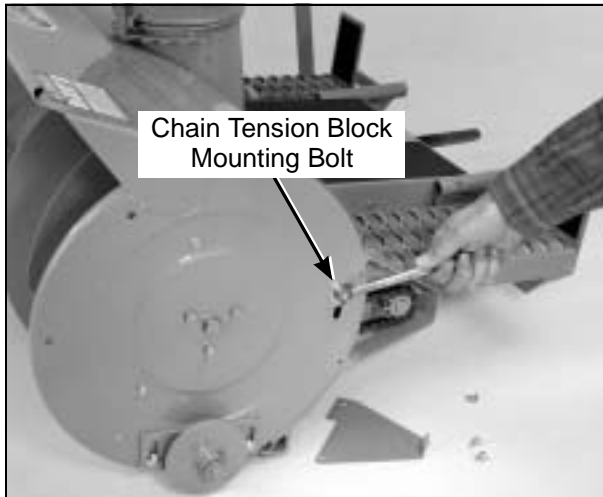

### Loosen Chain Tension Block Mounting Bolt

2. Position the chain tension block so the chain has 1/4 to 1/2 in. (6 to 13 mm) of slack.
3. Retighten the chain tension block mounting nut and bolt.
4. Recheck the drive chain tension.

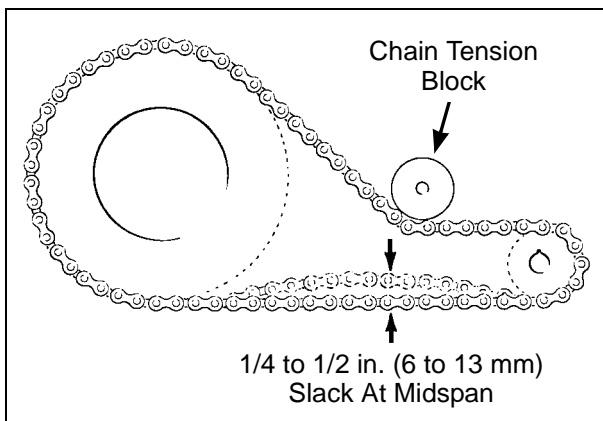

### Proper Chain Tension

#### Gauge Wheels or Skid Shoes

Inspect for paper adjustment of the gauge wheels or skid shoes **before each use**.

**IMPORTANT:** Failure to maintain proper adjustment of the gauge wheels or skid shoes can result in accelerated wear of the scraper blade.

Optional skid shoes can be used instead of the gauge wheels to operate the snowblower on soft surfaces. Adjust the gauge wheels or optional skid shoes as follows:

1. Park the tractor on a level surface and lower the snowblower.
2. Loosen the bolts that fasten the gauge wheels (or skid shoes) to the snowblower.

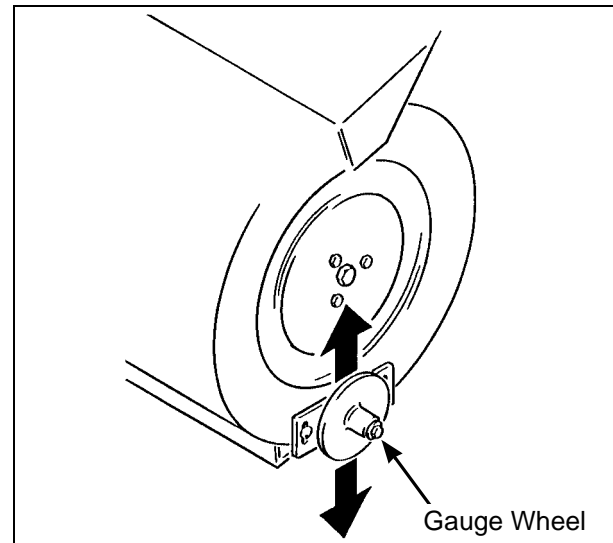

### Adjust Gauge Wheels

3. Position the gauge wheels (or skid shoes) so that the snowblower is level and the scraper blade has **light contact or slight clearance** with the surface.
4. Retighten the bolts that fasten the gauge wheels (or skid shoes) to the snowblower.

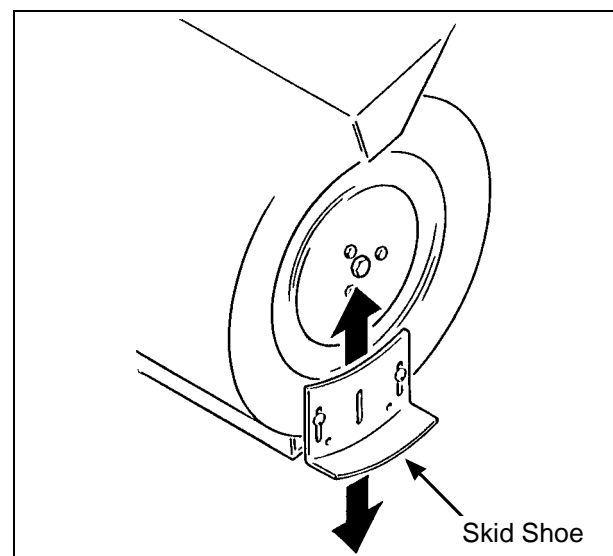

### Adjust Skid Shoes

# Removal and Storage Instructions

## REMOVAL

1. Park the tractor on a level surface and lower the snowblower.



### **WARNING**

**DO NOT attempt to remove the snowblower with the tractor engine running. Disengage the PTO clutch, stop the engine, and remove the ignition key. Wait for all movement to stop before getting off the seat.**

**To prevent accidental engine starting, disconnect the fuel solenoid wire [diesel engines] or the spark plug wire(s) [gasoline engines].**

2. Remove the hitch pins from the ends of the support arms.
3. Slide the PTO shaft out of the PTO coupler while sliding the snowblower off the tractor support arms.

## END OF SEASON STORAGE

1. Clean the snowblower thoroughly.
2. Repaint all parts where paint has worn.

**NOTE:** Rustproofing or painting **every year** will prolong the life of the snowblower components and moving parts.

3. When the snowblower is dry, lubricate all moving parts. Apply lubricant liberally to all surfaces to protect against rust.
4. Store the snowblower in a dry place.

# MAIN BODY COMPONENTS

ITEM NO.	PART NO.	DESCRIPTION	NO. REQ'D	ITEM NO.	PART NO.	DESCRIPTION	NO. REQ'D
<b>Spout/Deflector Assembly</b>				<b>Fasteners</b>			
1	5640	Grommet (1/4 x 3/8)	1	F004		1/4-20 Keps Nut	7
2	5641	Handle, Deflector Position Control	1	F005		1/4-20 ESNA Nut	3
3	5685-1	Decal, Danger (#23555)	2	F009		5/16-18 Whiz Locknut	6***
4	5604	Spout Deflector (Includes Item # 2)	1	F020		5/16-18 ESNA Nut	6
5	5639	Deflector Gasket	1	F029		1/4-20 x 1/2 Hex Bolt	4
6	5617-1	Spout Discharge Guard	1	F031		1/4-20 x 5/8 Hex Bolt	2
7	5603-2	Spout	1	F032		1/4-20 x 3/4 Hex Bolt	2
	5603-6	Spout Assembly (Includes Items # 1-12, F005, F020, F029, F032, F034, F049, F050, F061, F091, F177, F178, F236 & F310)	*	F034		5/16-18 x 3/4 Hex Bolt	5
				F035		5/16-18 x 1-1/4 Hex Bolt	2
				F049		5/16 SAE Washer	4
				F050		1/4 SAE Washer	1
				F061		1/4 Internal Star Lock Washer	5
8	5618	Spout Rotation Stop	1	F069		3/32 x 1/2 Cotter Pin	4
9	5229	Extension Spring (1/2 x 2-1/4)	1	F091		5/16-18 x 5/8 Hex Bolt	1
10	5616	Handle, Spout Position Control	1	F093		5/16-18 x 1 Hex Bolt	2
11	5642	Spring, Deflector Handle	1	F111		1/8 x 3/4 Cotter Pin	1
12	5643	Plastic Tip, Handle	1	F134		AN960816L Washer	4♦♦
				F168		5/16 Split Lock Washer	2
				F169		5/16-18 x 1 Carriage Bolt	6***
				F170		5/16 x 1 x 7/64 Washer	2
				F172		1/4-20 x 3/4 Carriage Bolt	7
				F173		5/16-18 x 3/4 Carriage Bolt	4
				F176		#14 x 1/2" Sheet Metal Screw	6
				F177		5/16 x 1-1/2 Fender Washer	2
				F178		1/4 x 1 Fender Washer	6
				F209		.765 x 1.312 x .032 Washer	4
				F236		1/4-20 x 1-3/4 Hex Bolt	1
				F310		5/16 x 1-1/8 x 3/16 Washer	1
<b>Housing/Frame Assembly</b>				* Service Part Only			
13	5747-5	Safety Tread (6 x 11-1/2)	2	** May be purchased as a factory-installed option or as a kit for dealer installation. Contact your Walker dealer. Kit Replaces Part 5629-2, and Includes Items # F009 & F169.			
14	5607	Cover (Includes Item # 13)	1	*** Six (6) F009 furnished with Standard Assembly. Installation of Skid Shoe Kit includes an additional six (6) F009 and six (6) F169.			
15	5850-1	Handle Grip	1	♦ Housing and Frame shown only for models prior to S/N 99-1042. For models with S/N 99-1042 and later, refer to detail shown in <b>AUGER AND DRIVETRAIN COMPONENTS</b> (Page 36).			
16	5800	Decal, Walker Mower (4 x 7-1/2)	1	♦♦ Average of four (4) F134 used per assembly. Adjust as required.			
17	5685-2	Decal, Warning (#23569)	1				
18	5610	Scraper Blade (Includes Items # F004 & F172)	1				
19	5605	Auger Guard	2				
20	5611	Skid Shoe (Heat Treated)	*				
	5611-1	Skid Shoe Kit (Optional) (Includes Items # 20, F009 & F169)	1** ***				
21	5629-2	Gauge Wheel	2				
	5629	Snowblower Gauge Wheel Assembly (Includes Items # 21, 22, 23, F034, F168, F170 & F209)	2				
22	5830	Grease Fitting	7				
23	5629-1	Wheel Bracket	2				
24	5743-2	Extension Spring (1-1/2 x 7-3/4)	2				
25	5653	Chain Shackle (5/16) (Includes Item # F069)	4				
26	5655	Lift Chain (4-1/2)	2				
27	5628-2	Lift Bracket	2				
28	5747-4	Safety Tread (3-1/4 x 4-1/2)	2				
29	5606	Chain Guard	1				
30	NS	Housing & Frame (Includes Items # 3, 16, 17 & 28)	1♦				
31	5654	Lift Trigger	1				
32	5227-1	Extension Spring (1/2 x 4)	1				

Use only genuine **Walker** replacement parts.

Effective Date 04-01-99

# MAIN BODY COMPONENTS

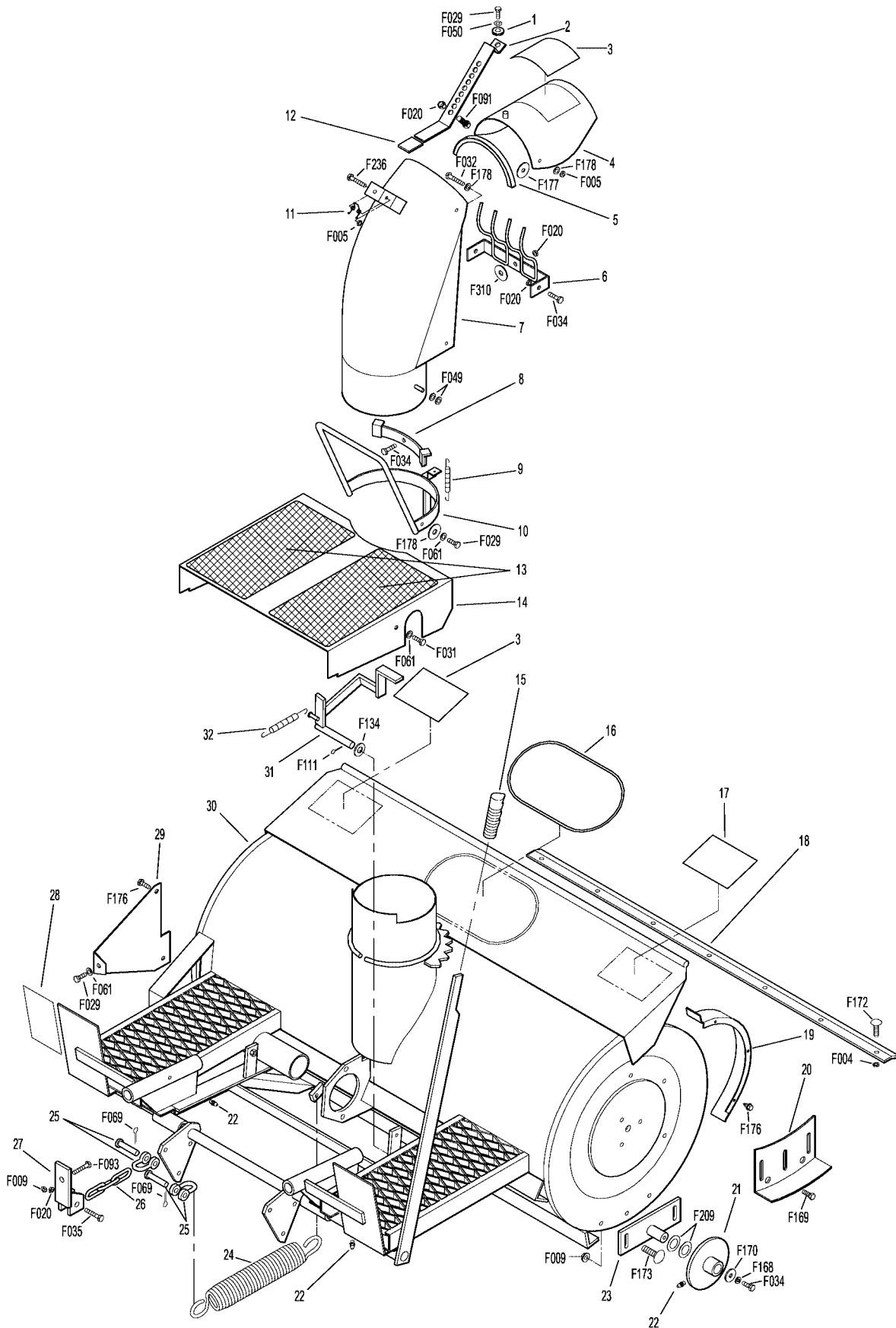

Effective Date 04-01-99

Use only genuine Walker replacement parts.

# AUGER AND DRIVETRAIN COMPONENTS

ITEM NO.	PART NO.	DESCRIPTION	NO. REQ'D	ITEM NO.	PART NO.	DESCRIPTION	NO. REQ'D
<b>Auger Assembly</b>				<b>Fasteners</b>			
1	5602	Auger	1	F009		5/16-18 Whiz Locknut	1
	5602-4	Auger Assembly (Includes Items # 1, 4, 5, 6, 7, F034 & F168)	*	F012		3/8-16 Keps Nut	2
2	5615	Key Plate, Auger Shaft	1	F034		5/16-18 x 3/4 Hex Bolt	9
3	5613	1-1/16 x 1-1/2 x .155 Washer	2	F039		3/8-16 x 1-1/4 Hex Bolt	2
4	5614	Drive Sprocket, Auger (41-35T)	1	F064		1/8 x 1/2 Woodruff Key (#3)	1
5	5609	Spindle Bearing & Collar (Includes Item # F309)	2	F065		3/16 x 3/4 Woodruff Key (#9)	2
6	5608	Auger Shaft (1 x 35-1/2)	1	F067		3/16 x 3/16 x 1 Key	1
7	5612	Bearing Retainer Plate	1	F069		3/32 x 1/2 Cotter Pin	1♦
<b>Drivetrain Components</b>				F074		1/4-20 x 3/8 Set Screw	3
8	5052-3	1.375 x .750 x .187 Washer, Oblong	2	F076		3/8-16 x 5/8 SQH Set Screw	1
9	5050-1	Right Angle Gearbox	1**	F091		5/16-18 x 5/8 Hex Bolt	3
10	5631	Flex Coupling Half (7/8 Bore) (Includes Item # F110)	1	F110		5/16-18 x 1/2 Set Screw	2
11	5624	PTO Shaft (Includes Item # F076)	1**	F168		5/16 Split Lock Washer	12
12	5632	Spider, Flexible Coupling	1	F174		1/2-13 x 1-1/4 Hex Bolt	2
13	5630	Flex Coupling Half (3/4 Bore) (Includes Item # F110)	1	F175		1/2 Split Lock Washer	2
14	5268	Bearing (3/4), Includes Locking Collar	2	F208		5/16-18 x 2-1/4 Hex Bolt	1
15	5595-2	Intake Cover (10" Blower)	1***	F295		3/16 x 1-1/2 Split Spring Pin	1♦
16	5635	Drive Shaft (3/4 x 14-1/8)	1	F309		1/4-28 x 1/4 Set Screw	2
17	5841	Retainer Washer	2	* Service Part Only ** Used only on models prior to S/N 99-1042. *** Plugs blower when GHS is not in use. Furnished only with Mulching Decks, SD Decks used on a GHS Tractor, Rotary Broom Attachment and Snowblower Attachment. ♦ Used only on models with S/N 99-1042 and later. (Item # 24 is sold as Service Part Only.)			
18	5626-2	Chain Tension Block	1				
19	5233	Transmission Sprocket (41-10T)	1				
20	5843-2	Clutch Spacer Washer	1				
21	5622	Drive Chain (#420 x 66)	1				
22	5050-10	Right Angle Gearbox	1♦				
23	5624-15	PTO Shaft (Includes Items # 24 & F295)	1♦				
24	8067-10	Shear Pin w/Cotter (Set of 5) (Includes Item # F069)	♦				

Use only genuine **Walker** replacement parts.

Effective Date 04-01-99





# KEY TO ABBREVIATIONS USED IN ILLUSTRATED PARTS LIST

<i>Abbreviation</i>	<i>What it Represents</i>
AT.....	All-Terrain
CCW.....	Counter-clockwise
Conn.....	Connector
CW.....	Clockwise
DGHS.....	Deck, Grass Handling System (number refers to size in inches)
DML.....	Deck, Mulching (number refers to size in inches)
DSD.....	Deck, Side Discharge (number refers to size in inches)
ESNA (Fastener).....	Nylon Insert Locknut
FSC.....	Forward Speed Control
GA.....	Gauge
gal.....	gallon
GHS.....	Grass Handling System
GR (Fastener).....	Grade
ID.....	Inside Diameter
" or in. (Dimension).....	inches
LH.....	Left Hand (orientated with operator on seat)
mm (Dimension).....	millimeters
MS (Fastener).....	Machine Screw
NPT.....	National Pipe Thread
NS (as part number).....	Item is not sold by Walker Manufacturing
OAL.....	Overall Length
OD.....	Outside Diameter
oz.....	ounce
PFHMS (Fastener).....	Phillips Flat Head Machine Screw
P/N.....	Part Number
PPHMS (Fastener).....	Phillips Pan Head Machine Screw
PPHSM (Fastener).....	Phillips Pan Head Sheet Metal (Screw)
PPHST (Fastener).....	Phillips Pan Head Self-Tapping (Screw)
PTHMS (Fastener).....	Phillips Truss Head Machine Screw
PTO.....	Power Take-Off
QKS.....	Quick Slide
qt.....	quart
RH.....	Right Hand (orientated with operator on seat)
SAE (Fastener).....	Society of Automotive Engineers
SB36.....	36 Inch Snowblower
SBH (Fastener).....	Socket Button Head (Bolt)
SD.....	Side Discharge
SFH (Fastener).....	Slotted Flat Head
SHC (Fastener).....	Socket Head Cap
SHL (Fastener).....	Shoulder (Bolt)
S/N.....	Serial Number
Spg.....	Spring
SQH (Fastener).....	Square Head
SS (Fastener).....	Stainless Steel
Term.....	Terminal

Use only genuine **Walker** replacement parts.

Effective Date 04-01-99

# **LIMITED WARRANTY FOR WALKER MODEL SB36 SINGLE-STAGE SNOWBLOWER**

## **1. WHAT THIS WARRANTY COVERS, AND FOR HOW LONG:**

Walker Manufacturing company will, at its option, repair or replace, without charge, any part covered by this warranty which is found to be defective in material and/or workmanship within one (1) year after date of sale to the original retail purchaser unless the product is used for rental purposes, in which case this warranty is limited to ninety (90) days. At Walker's request, customer will make the defective part available for inspection by Walker and/or return the defective part to Walker, transportation charges prepaid. All parts and components of the Walker Model SB36 Snowblower are covered by this warranty **except** the following components which are warranted separately by their respective manufacturers:

Peerless Gearboxes

The available warranties covering these items are furnished with each snowblower. Walker does not assume any warranty obligation, liability or modification for these items, which are covered exclusively by the stated warranty of the respective manufacturers noted above.

## **2. WHAT THIS WARRANTY DOES NOT COVER:**

- A. This warranty does not cover defects caused by depreciation or damage caused by normal wear, accidents, improper maintenance, improper use or abuse of the product, alterations, or failure to follow the instructions contained in the Owner's Manual for operation and maintenance.
- B. The customer shall pay any charges for making service calls and/or for transporting the snowblower to and from the place where the inspection and/or warranty work is performed.

## **3. HOW TO OBTAIN SERVICE UNDER THIS WARRANTY:**

Warranty service can be arranged by contacting the dealer where you purchased the snowblower or by contacting Walker Manufacturing Company, 5925 East Harmony Road, Ft. Collins, CO 80528. Proof of the date of purchase may be required to verify warranty coverage.

## **4. WARRANTY LIMITATION:**

- A. **THERE IS NO OTHER EXPRESS WARRANTY. ANY WARRANTY THAT MAY BE IMPLIED FROM THIS PURCHASE INCLUDING MERCHANTABILITY AND FITNESS FOR A PARTICULAR PURPOSE IS HEREBY LIMITED TO THE DURATION OF THIS WARRANTY AND TO THE EXTENT PERMITTED BY LAW ANY AND ALL IMPLIED WARRANTIES ARE EXCLUDED.** Some states do not allow limitations on how long an implied warranty lasts, so the above limitations may not apply to you.
- B. **WALKER WILL NOT BE LIABLE FOR ANY INCIDENTAL, CONSEQUENTIAL, OR SPECIAL DAMAGES AND/OR EXPENSES IN CONNECTION WITH THE PURCHASE OR USE OF THE SNOWBLOWER.** Some states do not allow the exclusion or limitation of incidental or consequential damages, so the above limitation(s) or exclusion(s) may not apply to you.
- C. Only the warranty expressed in this limited warranty shall apply and no dealer, distributor, or individual is authorized to amend, modify, or extend this warranty in any way. Accordingly, additional statements such as dealer advertising or presentations, whether oral or written, do not constitute warranties by Walker, and should not be relied upon.
- D. This warranty gives you specific legal rights, and you may also have other rights which vary from state to state.

# WALKER MOWERS™

WALKER MFG. CO. • 5925 E. HARMONY ROAD, FORT COLLINS, CO 80528 • (970) 221-5614  
FORM NO. 050399 PRINTED IN USA ©1999 WALKER MFG. CO

## Free Manuals Download Website

<http://myh66.com>

<http://usermanuals.us>

<http://www.somanuals.com>

<http://www.4manuals.cc>

<http://www.manual-lib.com>

<http://www.404manual.com>

<http://www.luxmanual.com>

<http://aubethermostatmanual.com>

Golf course search by state

<http://golfingnear.com>

Email search by domain

<http://emailbydomain.com>

Auto manuals search

<http://auto.somanuals.com>

TV manuals search

<http://tv.somanuals.com>