

SUPERO®

SUPERSERVER

5017C-MTF
5017C-MTRF

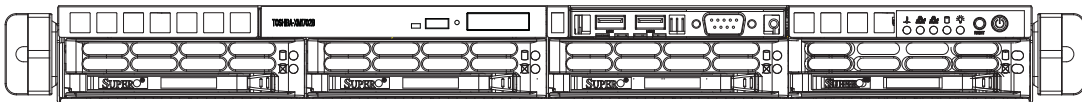

USER'S MANUAL

1.0c

The information in this User's Manual has been carefully reviewed and is believed to be accurate. The vendor assumes no responsibility for any inaccuracies that may be contained in this document, makes no commitment to update or to keep current the information in this manual, or to notify any person or organization of the updates. **Please Note: For the most up-to-date version of this manual, please see our web site at www.supermicro.com.**

Super Micro Computer, Inc. ("Supermicro") reserves the right to make changes to the product described in this manual at any time and without notice. This product, including software and documentation, is the property of Supermicro and/or its licensors, and is supplied only under a license. Any use or reproduction of this product is not allowed, except as expressly permitted by the terms of said license.

IN NO EVENT WILL SUPERMICRO BE LIABLE FOR DIRECT, INDIRECT, SPECIAL, INCIDENTAL, SPECULATIVE OR CONSEQUENTIAL DAMAGES ARISING FROM THE USE OR INABILITY TO USE THIS PRODUCT OR DOCUMENTATION, EVEN IF ADVISED OF THE POSSIBILITY OF SUCH DAMAGES. IN PARTICULAR, SUPERMICRO SHALL NOT HAVE LIABILITY FOR ANY HARDWARE, SOFTWARE, OR DATA STORED OR USED WITH THE PRODUCT, INCLUDING THE COSTS OF REPAIRING, REPLACING, INTEGRATING, INSTALLING OR RECOVERING SUCH HARDWARE, SOFTWARE, OR DATA.

Any disputes arising between manufacturer and customer shall be governed by the laws of Santa Clara County in the State of California, USA. The State of California, County of Santa Clara shall be the exclusive venue for the resolution of any such disputes. Super Micro's total liability for all claims will not exceed the price paid for the hardware product.

FCC Statement: This equipment has been tested and found to comply with the limits for a Class A digital device pursuant to Part 15 of the FCC Rules. These limits are designed to provide reasonable protection against harmful interference when the equipment is operated in a commercial environment. This equipment generates, uses, and can radiate radio frequency energy and, if not installed and used in accordance with the manufacturer's instruction manual, may cause harmful interference with radio communications. Operation of this equipment in a residential area is likely to cause harmful interference, in which case you will be required to correct the interference at your own expense.

California Best Management Practices Regulations for Perchlorate Materials: This Perchlorate warning applies only to products containing CR (Manganese Dioxide) Lithium coin cells. "Perchlorate Material-special handling may apply. See www.dtsc.ca.gov/hazardouswaste/perchlorate"

WARNING: Handling of lead solder materials used in this product may expose you to lead, a chemical known to the State of California to cause birth defects and other reproductive harm.

Manual Revision 1.0c
Release Date: January 2, 2012

Unless you request and receive written permission from Super Micro Computer, Inc., you may not copy any part of this document.

Information in this document is subject to change without notice. Other products and companies referred to herein are trademarks or registered trademarks of their respective companies or mark holders.

Copyright © 2012 by Super Micro Computer, Inc.
All rights reserved.

Printed in the United States of America

Preface

About This Manual

This manual is written for professional system integrators and PC technicians. It provides information for the installation and use of the SuperServer 5017C-MTF/5017C-MTRF. Installation and maintenance should be performed by experienced technicians only.

The SuperServer 5017C-MTF/5017C-MTRF is a high-end server based on the SC-813MTQ-350B/SC813MTQ-R400B 1U rackmount chassis and the Super X9SCL-F single processor serverboard.

Manual Organization

Chapter 1: Introduction

The first chapter provides a checklist of the main components included with the server system and describes the main features of the X9SCL-F serverboard and the SC813MTQ chassis.

Chapter 2: Server Installation

This chapter describes the steps necessary to install the SuperServer 5017C-MTF/5017C-MTRF into a rack and check out the server configuration prior to powering up the system. If your server was ordered without processor and memory components, this chapter will refer you to the appropriate sections of the manual for their installation.

Chapter 3: System Interface

Refer here for details on the system interface, which includes the functions and information provided by the control panel on the chassis as well as other LEDs located throughout the system.

Chapter 4: System Safety

You should thoroughly familiarize yourself with this chapter for a general overview of safety precautions that should be followed when installing and servicing the SuperServer 5017C-MTF/5017C-MTRF.

Chapter 5: Advanced Serverboard Setup

Chapter 5 provides detailed information on the X9SCL-F serverboard, including the locations and functions of connections, headers and jumpers. Refer to this chapter when adding or removing processors or main memory and when reconfiguring the serverboard.

Chapter 6: Advanced Chassis Setup

Refer to Chapter 6 for detailed information on the SC813MTQ server chassis. You should follow the procedures given in this chapter when installing, removing or reconfiguring SATA or peripheral drives and when replacing system power supply modules and cooling fans.

Chapter 7: BIOS

The BIOS chapter includes an introduction to BIOS and provides detailed information on running the CMOS Setup Utility.

Appendix A: BIOS Error Beep Codes

Appendix B: System Specifications

Notes

Table of Contents

Chapter 1 Introduction

1-1	Overview	1-1
1-2	Motherboard Features.....	1-2
	Processors	1-2
	Memory	1-2
	Serial ATA.....	1-2
	I/O Ports	1-2
	Graphics Controller	1-2
1-3	Server Chassis Features	1-3
	System Power	1-3
	SATA Subsystem.....	1-3
	Control Panel	1-3
	Rear I/O Panel	1-3
	Cooling System	1-3
1-4	Contacting Supermicro.....	1-5

Chapter 2 Server Installation

2-1	Overview	2-1
2-2	Unpacking the System	2-1
2-3	Preparing for Setup.....	2-1
	Choosing a Setup Location.....	2-1
	Rack Precautions	2-2
	Server Precautions.....	2-2
	Rack Mounting Considerations	2-3
	Ambient Operating Temperature	2-3
	Reduced Airflow	2-3
	Mechanical Loading	2-3
	Circuit Overloading.....	2-3
	Reliable Ground	2-3
2-4	Installing the System into a Rack	2-4
	Identifying the Sections of the Rack Rails	2-4
	Installing the Rear Inner Rails	2-4
	Installing the Rack Rails	2-5
	Installing the Server into the Rack.....	2-6
	Installing the Server into a Telco Rack.....	2-7
2-5	Checking the Motherboard Setup	2-8
2-6	Checking the Drive Bay Setup.....	2-9

Chapter 3 System Interface

3-1	Overview	3-1
3-2	Control Panel Buttons	3-1
	Reset	3-1
	Power	3-1
3-3	Control Panel LEDs	3-2
	Overheat/Fan Fail	3-2
	NIC2	3-2
	NIC1	3-2
	HDD.....	3-2
	Power	3-3
3-4	Hard Drive Carrier LEDs.....	3-3

Chapter 4 System Safety

4-1	Electrical Safety Precautions	4-1
4-2	General Safety Precautions	4-2
4-3	ESD Precautions.....	4-3
4-4	Operating Precautions	4-4

Chapter 5 Advanced Motherboard Setup

5-1	Handling the Motherboard	5-1
	Precautions	5-1
	Unpacking	5-1
5-2	Processor and Heatsink Installation.....	5-2
	Installing the LGA1155 Processor	5-2
	Installing a Passive CPU Heatsink	5-4
	Removing the Heatsink.....	5-4
5-3	Connecting Cables.....	5-6
	Connecting Data Cables	5-6
	Connecting Power Cables	5-6
	Connecting the Control Panel.....	5-6
5-4	I/O Ports	5-7
5-5	Installing Memory	5-8
5-6	Adding PCI Cards	5-10
5-7	Motherboard Details.....	5-11
5-8	Connector Definitions	5-13
5-9	Jumper Settings	5-19
5-10	Onboard Indicators.....	5-21
5-11	SATA Drive Connections	5-22
5-12	Installing Drivers.....	5-23

Supero Doctor III..... 5-24

Chapter 6 Advanced Chassis Setup

6-1 Static-Sensitive Devices..... 6-1
 Precautions 6-1
 Unpacking 6-1
 6-2 Control Panel 6-2
 6-3 System Fans 6-3
 6-4 Drive Bay Installation/Removal 6-3
 Removing the Front Bezel 6-3
 SATA Drive Installation..... 6-4
 Accessing the Drive Bays 6-4
 SATA Backplane..... 6-5
 6-5 Power Supply 6-7
 Power Supply Failure..... 6-7

Chapter 7 BIOS

7-1 Introduction..... 7-1
 7-2 Main Setup 7-2
 7-3 Advanced Setup Configurations..... 7-4
 7-4 Event Logs 7-15
 7-5 IPMI Configuration 7-16
 7-6 Boot Settings 7-18
 7-7 Security Settings 7-19
 7-8 Exit Options..... 7-20

Appendix A BIOS Error Beep Codes

Appendix B System Specifications

Chapter 1

Introduction

1-1 Overview

The SuperServer 5017C-MTF/5017C-MTRF is a high-end server comprised of two main subsystems: the SC813MTQ-350B/SC813MTQ-R400B 1U server chassis and the X9SCL-F single processor motherboard. Please refer to our web site for information on operating systems that have been certified for use with the system (www.supermicro.com).

In addition to the motherboard and chassis, various hardware components have been included with the 5017C-MTF/5017C-MTRF, as listed below:

- Four sets of 4-cm counter-rotating fans (FAN-0065L4)
- One passive CPU heatsink (SNK-P0046P)
- One RSC-RR1U-E8 riser card for one PCI-E 2.0 x8 add-on card
- SATA Accessories
 - One SATA backplane (BPN-SAS-815TQ)
 - Four 2.5" hard drive carriers (CSE-PT39-B0)
 - One SATA cable (CBL-0186L)
- One rackmount kit (MCP-290-00050-0N)
- One CD containing drivers and utilities
- SuperServer 5017C-MTF/5017C-MTRF User's Manual

1-2 Motherboard Features

At the heart of the SuperServer 5017C-MTF/5017C-MTRF lies the X9SCL-F, a single processor motherboard based on Intel's C202 chipset. Below are the main features of the X9SCL-F (see Figure 1-1 for a block diagram of the chipset).

Processors

The X9SCL-F supports a single Intel® Xeon® E3-1200 Series processor or a Core™ i3-2100 Series processor in an LGA1155 socket. Please refer to the motherboard description pages on our web site for a complete listing of supported processors.

Memory

The X9SCL-F has four DIMM sockets that can support up to 32 GB of unbuffered DDR3-1333/1066 memory. Please refer to Chapter 5 for installing memory.

Serial ATA

An on-chip SATA controller is integrated into the X9SCL-F to provide a six-port, 3 Gb/sec Serial ATA subsystem, which is RAID 0, 1, 5 and 10 supported (RAID 5 supported with Windows OS only). The SATA drives are hot-swappable units. Note: The operating system you use must have RAID support to enable the hot-swap capability and RAID function of the SATA drives. Documentation on RAID setup guidelines can be found on our web site.

I/O Ports

The color-coded I/O ports include one COM port, a VGA (monitor) port, two USB 2.0 ports, PS/2 mouse and keyboard ports and two gigabit Ethernet ports. A dedicated IPMI LAN port is also included.

Graphics Controller

The X9SCL-F features an integrated ATI video controller based on the Matrox G200eW graphics chip, which has 16 MB of DDR2 memory.

1-3 Server Chassis Features

The following is a general outline of the main features of the SC813MTQ chassis.

System Power

When configured as a SuperServer 5017C-MTF, the SC813MTQ chassis includes a single 350W power supply. When configured as a SuperServer 5017C-MTRF, the SC813MTQ chassis includes a redundant 400W power supply.

SATA Subsystem

For the 5017C-MTF/5017C-MTRF, the SC813MTQ chassis was designed to support four SATA hard drives, which are hot-swappable units.

Note: The operating system you use must have RAID support to enable the hot-swap capability of the SATA drives (system-based RAID is not available for SATA).

Control Panel

The SC813MTQ's control panel provides important system monitoring and control information. LEDs indicate power on, network activity, hard disk drive activity and system overheat conditions. The control panel also includes a main power button and a system reset button. The front of the SC813MTQ also includes a COM port and two USB serial ports for easy access.

Rear I/O Panel

The SC813MTQ is a 1U rackmount chassis. Its I/O panel provides one PCI motherboard expansion slot, one COM port (another is internal), two USB ports, a parallel (printer) port, PS/2 mouse and keyboard ports, a VGA port and two Gb Ethernet ports.

Cooling System

The SC813MTQ chassis has an innovative cooling design that features four 4-cm high-performance system cooling fans. Each of these fans plug into a chassis fan header on the motherboard.

A fan speed control setting in BIOS allows fan speed to be determined by system temperature [the recommended setting is 3-pin (Server)].

**Figure 1-1. Intel C200 Chipset:
System Block Diagram**

Note: This is a general block diagram. Please see Chapter 5 for details.

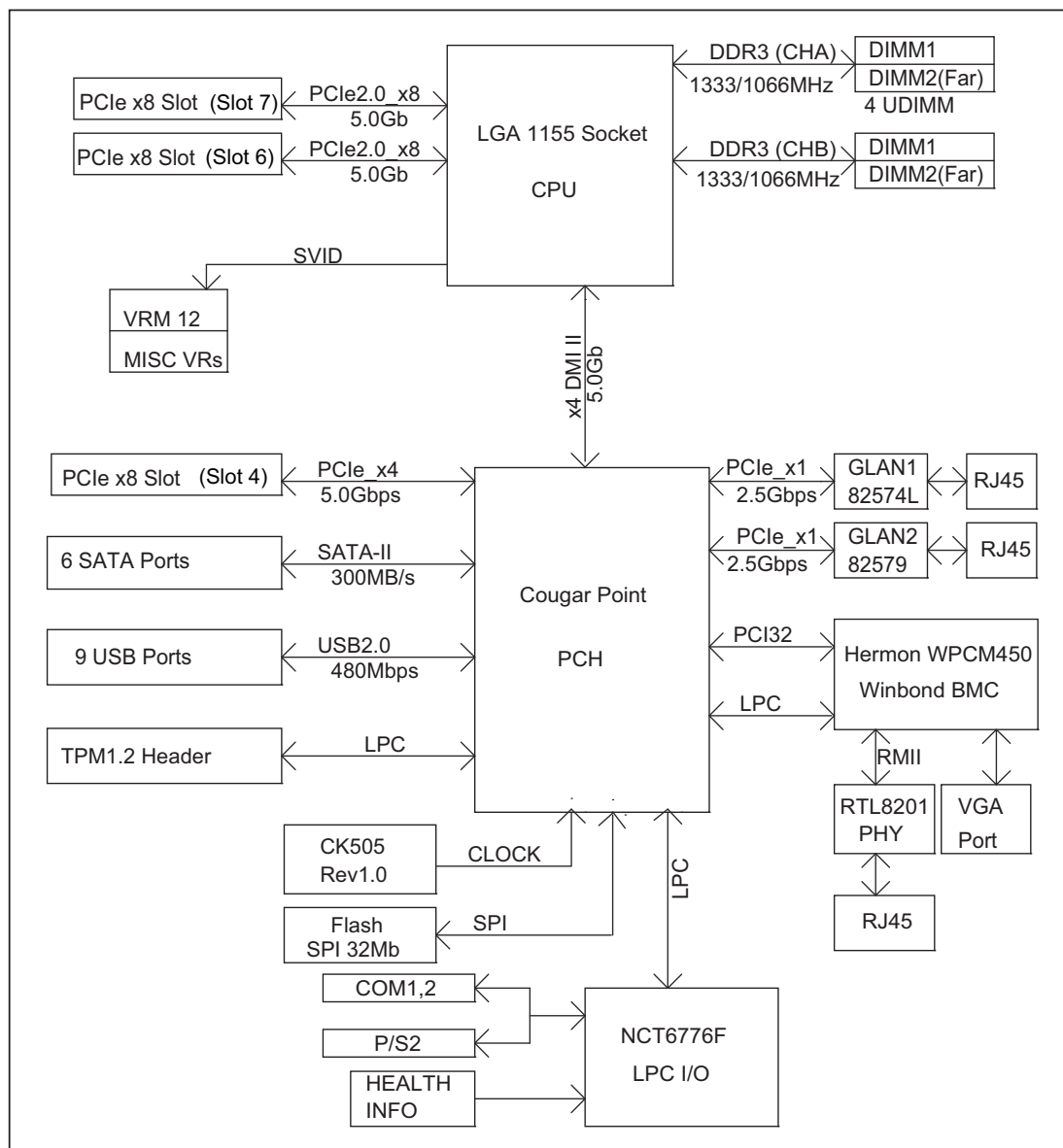

1-4 Contacting Supermicro

Headquarters

Address: Super Micro Computer, Inc.
980 Rock Ave.
San Jose, CA 95131 U.S.A.

Tel: +1 (408) 503-8000

Fax: +1 (408) 503-8008

Email: marketing@supermicro.com (General Information)
support@supermicro.com (Technical Support)

Web Site: www.supermicro.com

Europe

Address: Super Micro Computer B.V.
Het Sterrenbeeld 28, 5215 ML
's-Hertogenbosch, The Netherlands

Tel: +31 (0) 73-6400390

Fax: +31 (0) 73-6416525

Email: sales@supermicro.nl (General Information)
support@supermicro.nl (Technical Support)
rma@supermicro.nl (Customer Support)

Asia-Pacific

Address: Super Micro Computer, Inc.
4F, No. 232-1, Liancheng Rd.
Chung-Ho 235, Taipei County
Taiwan, R.O.C.

Tel: +886-(2) 8226-3990

Fax: +886-(2) 8226-3991

Web Site: www.supermicro.com.tw

Technical Support:

Email: support@supermicro.com.tw

Tel: 866-2-8226-5990

Notes

Chapter 2

Server Installation

2-1 Overview

This chapter provides a quick setup checklist to get your SuperServer 5017C-MTF/5017C-MTRF up and running. Following the steps in the order given should enable you to have the system operational within a minimal amount of time. This quick setup assumes that your 5017C-MTF/5017C-MTRF system has come to you with the processor and memory preinstalled. If your system is not already fully integrated with a motherboard, processor, system memory etc., please turn to the chapter or section noted in each step for details on installing specific components.

2-2 Unpacking the System

You should inspect the box the SuperServer 5017C-MTF/5017C-MTRF was shipped in and note if it was damaged in any way. If the server itself shows damage, you should file a damage claim with the carrier who delivered it.

Decide on a suitable location for the rack unit that will hold the SuperServer 5017C-MTF/5017C-MTRF. It should be situated in a clean, dust-free area that is well ventilated. Avoid areas where heat, electrical noise and electromagnetic fields are generated. You will also need it placed near a grounded power outlet. Read the Rack and Server Precautions in the next section.

2-3 Preparing for Setup

The box the SuperServer 5017C-MTF/5017C-MTRF was shipped in should include two sets of rail assemblies, six rail mounting brackets and the mounting screws you will need to install the system into the rack. Follow the steps in the order given to complete the installation process in a minimal amount of time. Please read this section in its entirety before you begin the installation procedure outlined in the sections that follow.

Choosing a Setup Location

- Leave enough clearance in front of the rack to enable you to open the front door completely (~25 inches) and approximately 30 inches of clearance in the back of the rack to allow for sufficient airflow and ease in servicing. This product is for

installation only in a Restricted Access Location (dedicated equipment rooms, service closets and the like).

- This product is not suitable for use with visual display work place devices according to §2 of the the German Ordinance for Work with Visual Display Units.



Warnings and Precautions!



Rack Precautions

- Ensure that the leveling jacks on the bottom of the rack are fully extended to the floor with the full weight of the rack resting on them.
- In single rack installation, stabilizers should be attached to the rack. In multiple rack installations, the racks should be coupled together.
- Always make sure the rack is stable before extending a component from the rack.
- You should extend only one component at a time - extending two or more simultaneously may cause the rack to become unstable.

Server Precautions

- Review the electrical and general safety precautions in Chapter 4.
- Determine the placement of each component in the rack *before* you install the rails.
- Install the heaviest server components on the bottom of the rack first, and then work up.
- Use a regulating uninterruptible power supply (UPS) to protect the server from power surges, voltage spikes and to keep your system operating in case of a power failure.
- Allow the hot plug SATA drives and power supply modules to cool before touching them.
- Always keep the rack's front door and all panels and components on the servers closed when not servicing to maintain proper cooling.

Rack Mounting Considerations

Ambient Operating Temperature

If installed in a closed or multi-unit rack assembly, the ambient operating temperature of the rack environment may be greater than the ambient temperature of the room. Therefore, consideration should be given to installing the equipment in an environment compatible with the manufacturer's maximum rated ambient temperature (T_{mra}).

Reduced Airflow

Equipment should be mounted into a rack so that the amount of airflow required for safe operation is not compromised.

Mechanical Loading

Equipment should be mounted into a rack so that a hazardous condition does not arise due to uneven mechanical loading.

Circuit Overloading

Consideration should be given to the connection of the equipment to the power supply circuitry and the effect that any possible overloading of circuits might have on overcurrent protection and power supply wiring. Appropriate consideration of equipment nameplate ratings should be used when addressing this concern.

Reliable Ground

A reliable ground must be maintained at all times. To ensure this, the rack itself should be grounded. Particular attention should be given to power supply connections other than the direct connections to the branch circuit (i.e. the use of power strips, etc.).

2-4 Installing the System into a Rack

This section provides information on installing the SuperServer 5017C-MTF/5017C-MTRF into a rack unit with the rack rails provided. If the server has already been mounted into a rack, you can skip ahead to Sections 2-5 and 2-6.

There are a variety of rack units on the market, which may mean the assembly procedure will differ slightly. You should also refer to the installation instructions that came with the rack unit you are using.

Identifying the Sections of the Rack Rails

You may have received rack rail hardware with the SuperServer 5017C-MTF/5017C-MTRF. (Two front inner rails should already be attached to the chassis.) This hardware consists of two rear inner rails that secure to the chassis, one on each side just behind the preinstalled front inner rails. Note that these two rails are left/right specific.

Installing the Rear Inner Rails

First, locate the right rear inner rail (the rail that will be used on the right side of the chassis when you face the front of the chassis). Align the two square holes on the rail against the hooks on the right side of the chassis. Securely attach the rail to the chassis with M4 flat head screws. Repeat these steps to install the left rear inner rail to the left side of the chassis (see Figure 2-1). You will also need to attach the rail brackets when installing into a telco rack.

Locking Tabs: Both chassis rails have a locking tab, which serves two functions. The first is to lock the server into place when installed and pushed fully into the rack, which is its normal position. Secondly, these tabs also lock the server in place when fully extended from the rack. This prevents the server from coming completely out of the rack when you pull it out for servicing.

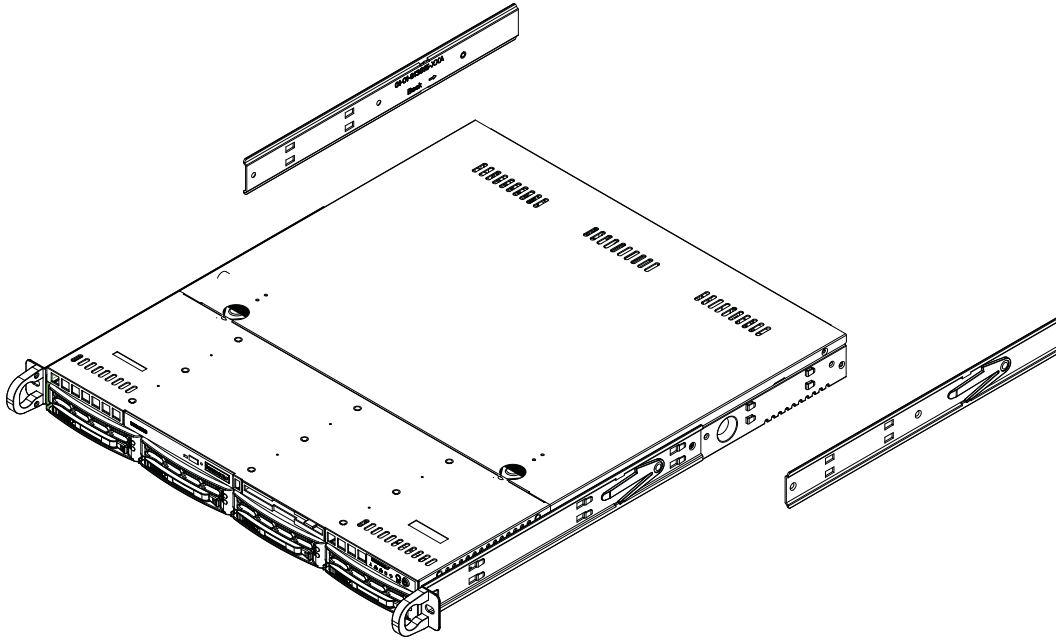
Figure 2-1. Installing Rear Inner Chassis Rails

Installing the Rack Rails

Determine where you want to place the SuperServer 5017C-MTF/5017C-MTRF in the rack ([see Rack and Server Precautions in Section 2-3](#)). Position the chassis rail guides at the desired location in the rack, keeping the sliding rail guide facing the inside of the rack. Screw the assembly securely to the rack using the brackets provided. Attach the other assembly to the other side of the rack, making sure that both are at the exact same height and with the rail guides facing inward.

Installing the Server into the Rack

You should now have rails attached to both the chassis and the rack unit. The next step is to install the server into the rack. Do this by lining up the rear of the chassis rails with the front of the rack rails. Slide the chassis rails into the rack rails, keeping the pressure even on both sides (you may have to depress the locking tabs when inserting). See Figure 2-2.

When the server has been pushed completely into the rack, you should hear the locking tabs "click".

**Figure 2-2. Installing the Server into a Rack
(with optional front bezel shown)**

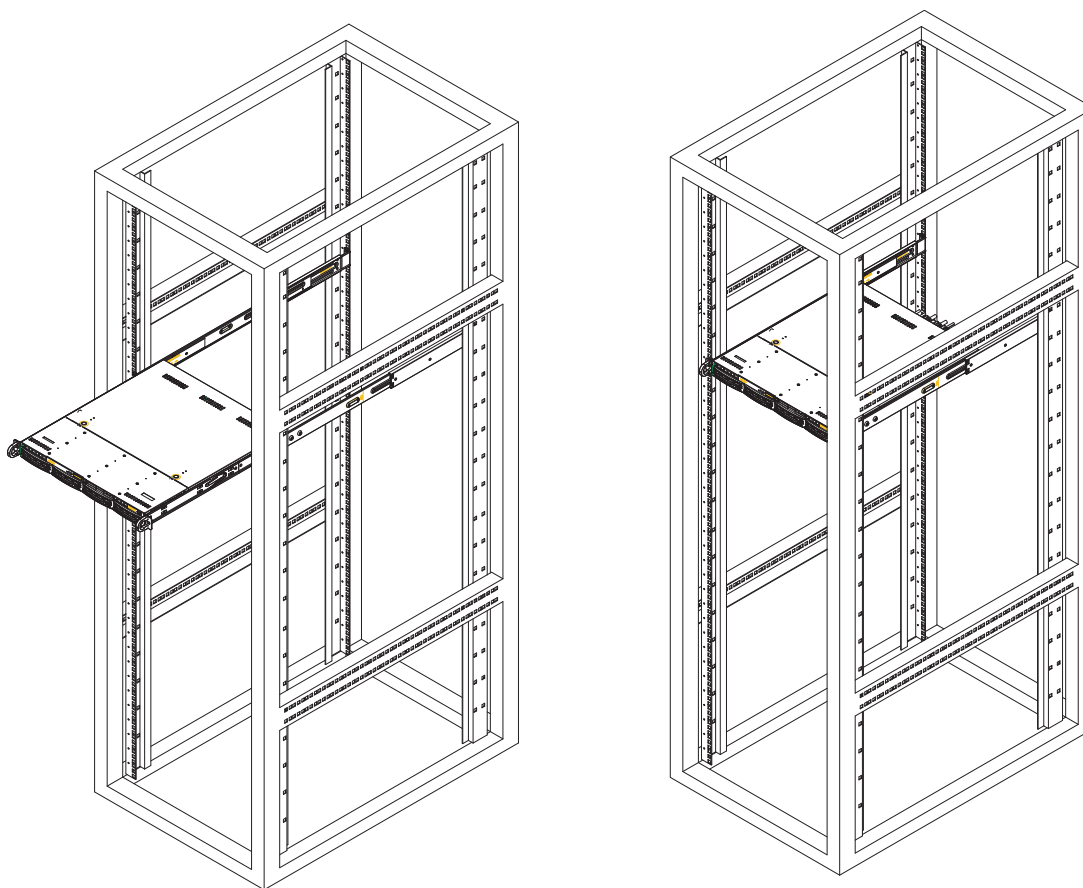

Installing the Server into a Telco Rack

To install the SuperServer 5017C-MTF/5017C-MTRF into a Telco type rack, use two L-shaped brackets on either side of the chassis (four total). First, determine how far the server will extend out the front of the rack. Larger chassis should be positioned to balance the weight between front and back. If a bezel is included on your server, remove it. Then attach the two front brackets to each side of the chassis, then the two rear brackets positioned with just enough space to accommodate the width of the rack. Finish by sliding the chassis into the rack and tightening the brackets to the rack.

**Figure 2-3. Installing the Server into a Telco Rack
(with optional front bezel shown)**

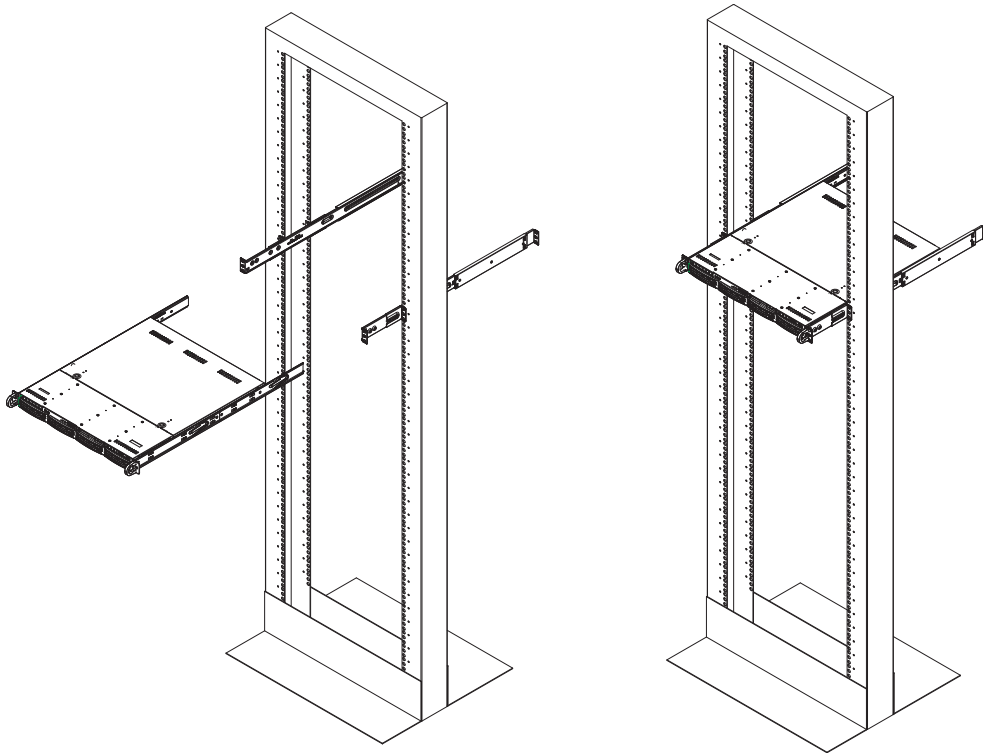

2-5 Checking the Motherboard Setup

After you install the 5017C-MTF/5017C-MTRF in the rack, you will need to open the unit to make sure the motherboard is properly installed and all the connections have been made.

Accessing the Inside of the System

1. Grasp the two handles on either side and pull the unit straight out until it locks (you will hear a "click").
2. Depress the two buttons on the top of the chassis to release the top cover. Push the cover away from you until it stops.
3. Lift the top cover from the chassis to gain full access to the inside of the server. See Figure 2-4.

Checking the Components

1. You may have the processor already installed into the system board. The processor should have its own heatsink attached. See Chapter 5 for instructions on processor installation.
2. Your 5017C-MTF/5017C-MTRF server system may have come with system memory already installed. Make sure all DIMMs are fully seated in their slots. For details on adding system memory, refer to Chapter 5.
3. If desired, you can install an add-on card to the system. See Chapter 5 for details on installing a PCI add-on card.
4. Make sure all power and data cables are properly connected and not blocking the airflow. See Chapter 5 for details on cable connections.

Figure 2-4.
Accessing the Inside of the System

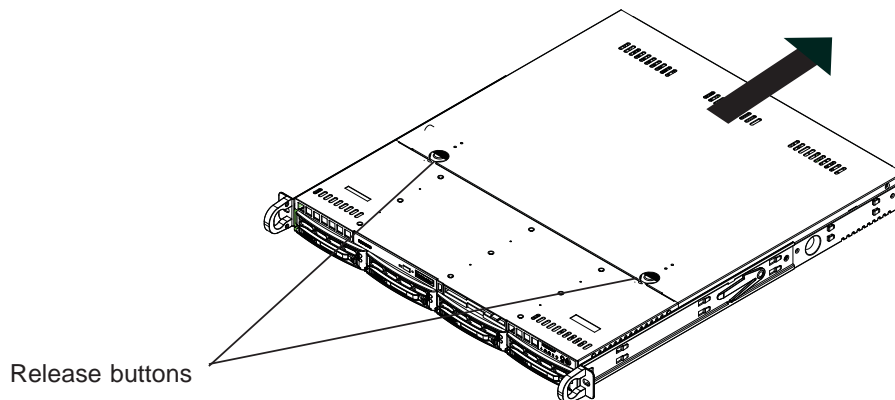

2-6 Checking the Drive Bay Setup

Next, you should check to make sure the peripheral drives and the SATA drives and their backplane have been properly installed and all essential connections have been made.

Checking the Drives

1. The SATA disk drives can be installed and removed from the front of the chassis without removing the top chassis cover.
2. Depending upon your system's configuration, your system may have one or more drives already installed. If you need to install drives, please refer to the appropriate section in Chapter 6.

Checking the Airflow

1. Airflow is provided by four high-performance 4-cm input fans. The system component layout was carefully designed to promote sufficient airflow through the small 1U rackmount space.
2. Also note that all power and data cables have been routed in such a way that they do not block the airflow generated by the fans.

Providing Power

1. Plug the power cord from the power supply unit into a high-quality power strip that offers protection from electrical noise and power surges. It is recommended that you use an uninterruptible power supply (UPS).
2. Depress the power button on the front of the chassis to power up the system.

Chapter 3

System Interface

3-1 Overview

There are several LEDs on the control panel as well as others on the hard drive carriers to keep you constantly informed of the overall status of the system as well as the activity and health of specific components. There are also two buttons on the chassis control panel and an on/off switch on the power supply. This chapter explains the meanings of all LED indicators and the appropriate response you may need to take.

3-2 Control Panel Buttons

There are two push-buttons located on the front of the chassis: a reset button and a power on/off button.



Reset

The reset button reboots the system.



Power

This is the main power button, which is used to apply or turn off the main system power. Turning off system power with this button removes the main power but keeps standby power supplied to the system.

3-3 Control Panel LEDs

The control panel located on the front of the SC813MTQ chassis has five LEDs. These LEDs provide you with critical information related to different parts of the system. This section explains what each LED indicates when illuminated and any corrective action you may need to take.



Overheat/Fan Fail

When this LED flashes, it indicates a fan failure. When on continuously it indicates an overheat condition, which may be caused by cables obstructing the airflow in the system or the ambient room temperature being too warm. Check the routing of the cables and make sure all fans are present and operating normally. You should also check to make sure that the chassis covers are installed. Finally, verify that the heatsinks are installed properly (see Chapter 5). This LED will remain flashing or on as long as the indicated condition exists.



NIC2

Indicates network activity on LAN2 when flashing.



NIC1

Indicates network activity on LAN1 when flashing.



HDD

Channel activity for all HDDs. This light indicates hard drive activity on the 5017C-MTF/5017C-MTRF when flashing.



Power

Indicates power is being supplied to the system's power supply units. This LED should normally be illuminated when the system is operating.

3-4 Hard Drive Carrier LEDs

Each drive carrier has two LEDs.

- **Green:** When illuminated, the green LED on the drive carrier indicates drive activity. A connection to the backplane enables this LED to blink on and off when that particular drive is being accessed.
- **Red:** The red LED to indicate a drive failure. If one of the drives fails, you should be notified by your system management software. Please refer to Chapter 6 for instructions on replacing failed drives.

Notes

Chapter 4

System Safety

4-1 Electrical Safety Precautions



Basic electrical safety precautions should be followed to protect yourself from harm and the SuperServer 5017C-MTF/5017C-MTRF from damage:

- Be aware of the locations of the power on/off switch on the chassis as well as the room's emergency power-off switch, disconnection switch or electrical outlet. If an electrical accident occurs, you can then quickly remove power from the system.
- Do not work alone when working with high voltage components.
- Power should always be disconnected from the system when removing or installing main system components, such as the serverboard, memory modules and floppy drive. When disconnecting power, you should first power down the system with the operating system first and then unplug the power cords of all the power supply units in the system.
- When working around exposed electrical circuits, another person who is familiar with the power-off controls should be nearby to switch off the power if necessary.
- Use only one hand when working with powered-on electrical equipment. This is to avoid making a complete circuit, which will cause electrical shock. Use extreme caution when using metal tools, which can easily damage any electrical components or circuit boards they come into contact with.
- Do not use mats designed to decrease static electrical discharge as protection from electrical shock. Instead, use rubber mats that have been specifically designed as electrical insulators.
- The power supply power cords must include a grounding plug and must be plugged into grounded electrical outlets.

- This product may be connected to an IT power system. In all cases, make sure that the unit is also reliably connected to Earth (ground).
- Serverboard Battery: **CAUTION** - There is a danger of explosion if the onboard battery is installed upside down, which will reverse its polarities (see Figure 4-1). This battery must be replaced only with the same or an equivalent type recommended by the manufacturer (CR2032). Dispose of used batteries according to the manufacturer's instructions.
- DVD-ROM Laser: **CAUTION** - this server may have come equipped with a DVD-ROM drive. To prevent direct exposure to the laser beam and hazardous radiation exposure, do not open the enclosure or use the unit in any unconventional way.
- Mainboard replaceable soldered-in fuses: Self-resetting PTC (Positive Temperature Coefficient) fuses on the mainboard must be replaced by trained service technicians only. The new fuse must be the same or equivalent as the one replaced. Contact technical support for details and support.

4-2 General Safety Precautions



Follow these rules to ensure general safety:

- Keep the area around the 5017C-MTF/5017C-MTRF clean and free of clutter.
- The 5017C-MTF/5017C-MTRF weighs approximately 38 lbs (~17.3 kg) when fully loaded. When lifting the system, two people at either end should lift slowly with their feet spread out to distribute the weight. Always keep your back straight and lift with your legs.
- Place the chassis top cover and any system components that have been removed away from the system or on a table so that they won't accidentally be stepped on.
- While working on the system, do not wear loose clothing such as neckties and unbuttoned shirt sleeves, which can come into contact with electrical circuits or be pulled into a cooling fan.

- Remove any jewelry or metal objects from your body, which are excellent metal conductors that can create short circuits and harm you if they come into contact with printed circuit boards or areas where power is present.
- After accessing the inside of the system, close the system back up and secure it to the rack unit with the retention screws after ensuring that all connections have been made.

4-3 ESD Precautions



Electrostatic Discharge (ESD) is generated by two objects with different electrical charges coming into contact with each other. An electrical discharge is created to neutralize this difference, which can damage electronic components and printed circuit boards. The following measures are generally sufficient to neutralize this difference before contact is made to protect your equipment from ESD:

- Use a grounded wrist strap designed to prevent static discharge.
- Keep all components and printed circuit boards (PCBs) in their antistatic bags until ready for use.
- Touch a grounded metal object before removing the board from the antistatic bag.
- Do not let components or PCBs come into contact with your clothing, which may retain a charge even if you are wearing a wrist strap.
- Handle a board by its edges only; do not touch its components, peripheral chips, memory modules or contacts.
- When handling chips or modules, avoid touching their pins.
- Put the serverboard and peripherals back into their antistatic bags when not in use.
- For grounding purposes, make sure your computer chassis provides excellent conductivity between the power supply, the case, the mounting fasteners and the serverboard.

4-4 Operating Precautions



Care must be taken to assure that the chassis cover is in place when the 5017C-MTF/5017C-MTRF is operating to assure proper cooling. Out of warranty damage to the system can occur if this practice is not strictly followed.

Figure 4-1. Installing the Onboard Battery

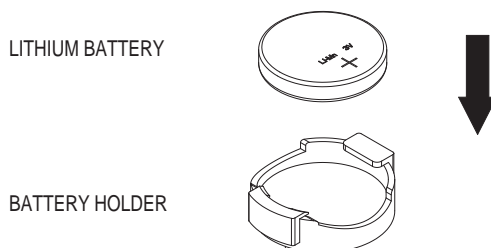

Please handle used batteries carefully. Do not damage the battery in any way; a damaged battery may release hazardous materials into the environment. Do not discard a used battery in the garbage or a public landfill. Please comply with the regulations set up by your local hazardous waste management agency to dispose of your used battery properly.

Chapter 5

Advanced Motherboard Setup

This chapter covers the steps required to install processors and heatsinks to the X9SCL-F motherboard, connect the data and power cables and install add-on cards. All motherboard jumpers and connections are described and a layout and quick reference chart are included in this chapter. Remember to close the chassis completely when you have finished working on the motherboard to protect and cool the system sufficiently.

5-1 Handling the Motherboard

Static electrical discharge can damage electronic components. To prevent damage to printed circuit boards, it is important to handle them very carefully (see Chapter 4). Also note that the size and weight of the motherboard can cause it to bend if handled improperly, which may result in damage. To prevent the motherboard from bending, keep one hand under the center of the board to support it when handling.

The following measures are generally sufficient to protect your equipment from static discharge.

Precautions

- Use a grounded wrist strap designed to prevent static discharge.
- Touch a grounded metal object before removing any board from its antistatic bag.
- Handle a board by its edges only; do not touch its components, peripheral chips, memory modules or gold contacts.
- When handling chips or modules, avoid touching their pins.
- Put the motherboard, add-on cards and peripherals back into their antistatic bags when not in use.

Unpacking

The motherboard is shipped in antistatic packaging to avoid static damage. When unpacking the board, make sure the person handling it is static protected.

5-2 Processor and Heatsink Installation

Notes:

- Always connect the power cord last and always remove it before adding, removing or changing any hardware components. Make sure that you install the processor into the CPU socket before you install the CPU heatsink.
- If you buy a CPU separately, make sure that you use an Intel-certified multi-directional heatsink only.
- Make sure to install the motherboard into the chassis before you install the CPU heatsinks.
- When receiving a motherboard without a processor pre-installed, make sure that the plastic CPU socket cap is in place and none of the socket pins are bent; otherwise, contact your retailer immediately.
- Refer to the Supermicro web site for updates on CPU support.

Installing the LGA1155 Processor

1. Press the load lever to release the load plate, which covers the CPU socket, from its locked position.
2. Gently lift the load lever to open the load plate. Remove the plate cap.

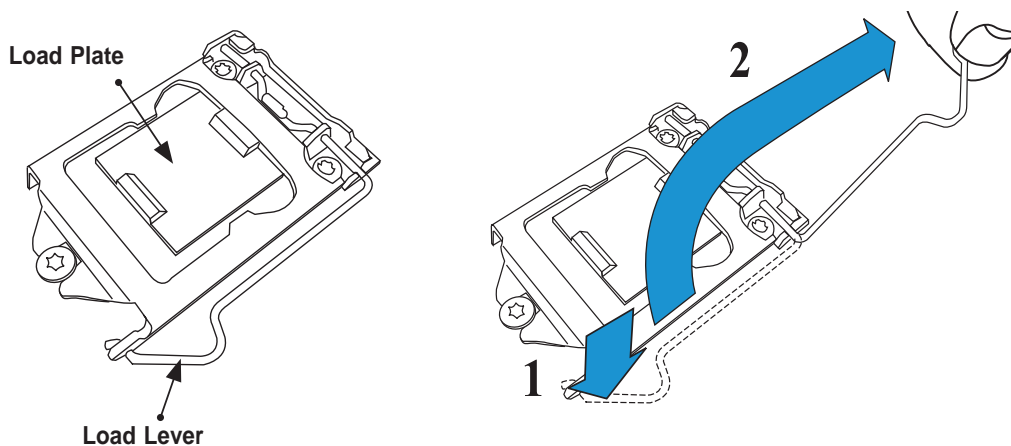

- Use your thumb and your index finger to hold the CPU at the top center edge and the bottom center edge of the CPU.

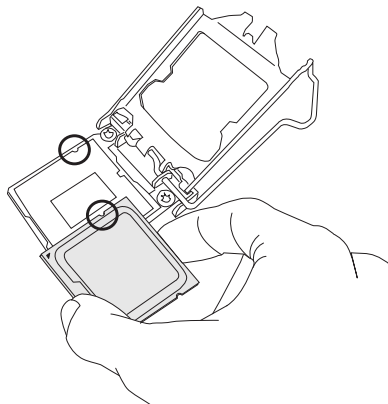

- Align the CPU key (the semi-circle cutouts) against the socket keys. Once aligned, carefully lower the CPU straight down to the socket. (Do not drop the CPU on the socket. Do not move the CPU horizontally or vertically.)

Do not rub the CPU against the surface or against any pins of the socket to avoid damage to the CPU or the socket.)

With the CPU inside the socket, inspect the four corners of the CPU to make sure that the CPU is properly installed.

- Use your thumb to gently push the load lever down to the lever lock.

Save the plastic PnP cap. The motherboard must be shipped with the PnP cap properly installed to protect the CPU socket pins. Shipment without the PnP cap properly installed will cause damage to the socket pins.

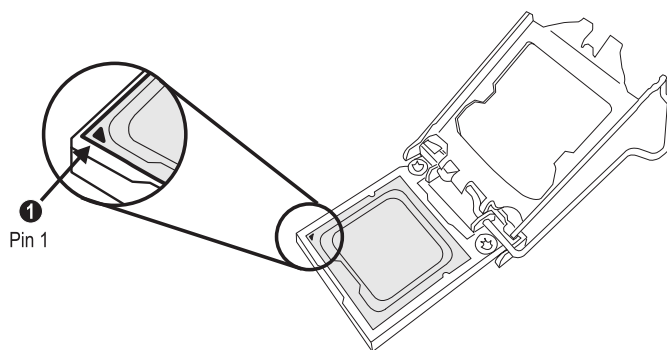

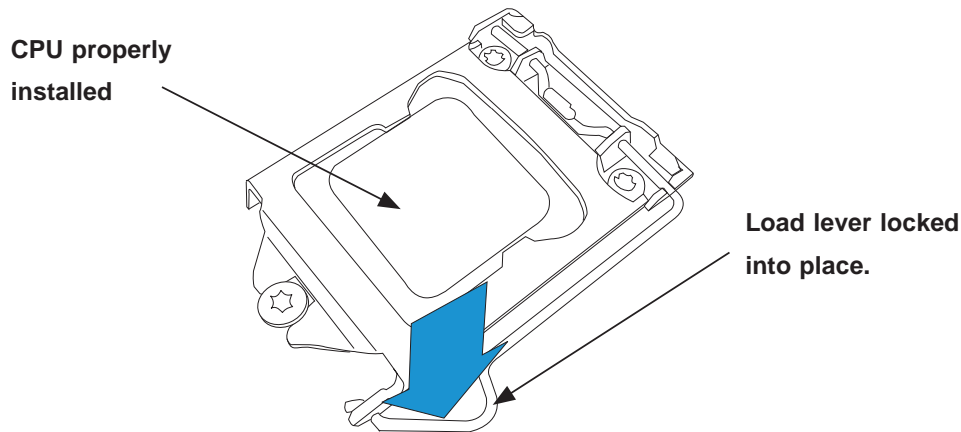

Warning: The CPU will only seat inside the socket in one direction. Make sure it is properly inserted before closing the load plate. If it doesn't close properly, do not force it as it may damage your CPU. Instead, open the load plate again and double-check that the CPU is aligned properly.

Installing a Passive CPU Heatsink

1. Do not apply any thermal grease to the heatsink or the CPU die -- the required amount has already been applied.
2. Place the heatsink on top of the CPU so that the four mounting holes are aligned with those on the motherboard and the heatsink bracket underneath.
3. Screw in two diagonal screws (i.e., the #1 and the #2 screws) until just snug (do not over-tighten the screws to avoid possible damage to the CPU.)
4. Finish the installation by fully tightening all four screws.

Removing the Heatsink



Warning: We do not recommend removing the CPU or the heatsink. However, if you do need to remove the heatsink, please follow the instructions below to prevent damage to the CPU or other components.

1. Unscrew the heatsink screws from the motherboard in the sequence as shown in the illustration below.
2. Gently wriggle the heatsink to loosen it from the CPU (do not use excessive force).

Figure 5-3. Installing the Heatsink

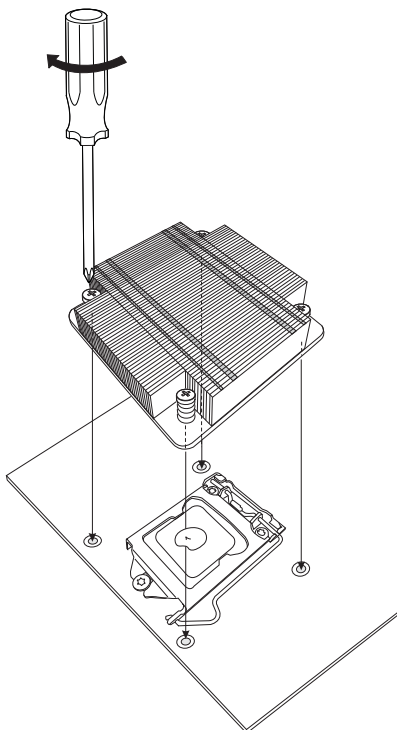

3. Once the CPU is loose, remove it from the CPU socket.
4. Clean the surface of the CPU and the heatsink, removing the used thermal grease. Reapply the proper amount of thermal grease on the surface before re-installing the CPU and the heatsink.

Figure 5-4. Removing the Heatsink

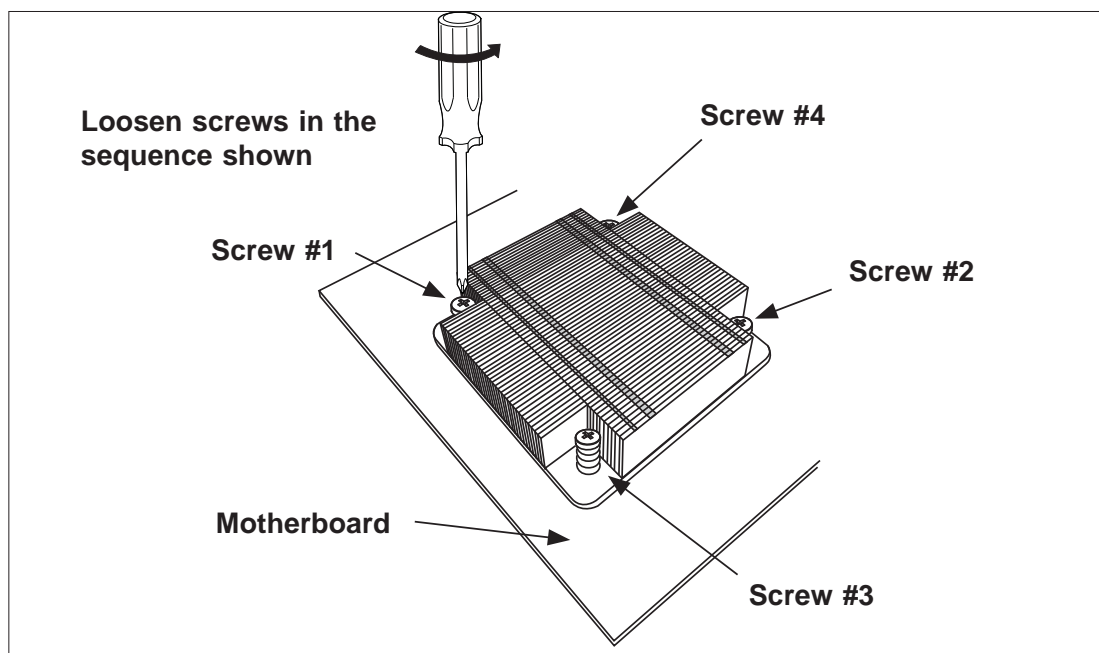

5-3 Connecting Cables

Now that the processors are installed, the next step is to connect the cables to the motherboard. These include the data (ribbon) cables for the peripherals and control panel and the power cables.

Connecting Data Cables

The cables used to transfer data from the peripheral devices have been carefully routed in preconfigured systems to prevent them from blocking the flow of cooling air that moves through the system from front to back. If you need to disconnect any of these cables, you should take care to reroute them as they were originally after reconnecting them (make sure the red wires connect to the pin 1 locations). If you are configuring the system, keep the airflow in mind when routing the cables.

The following data cables (with their motherboard connector locations noted) should be connected.

See the motherboard layout diagram in this chapter for connector locations.

- Control Panel cable (JF1, see next page)
- SATA cables (SATA1 ~ SATA5)
- SGPIO cable (T-SGPIO1 to SATA backplane)

Connecting Power Cables

The X9SCL-F has a 24-pin primary power supply connector designated "JPW1" for connection to the ATX power supply. Connect the appropriate connector from the power supply to JPW1 to supply power to the motherboard. See the Connector Definitions section in this chapter for power connector pin definitions.

In addition, your power supply must be connected to the 8-pin Processor Power connector at JPW2.

Connecting the Control Panel

JF1 contains header pins for various front control panel connectors. See Figure 5-1 for the pin locations of the various front control panel buttons and LED indicators. Please note that even and odd numbered pins are on opposite sides of each header.

All JF1 wires have been bundled into single keyed ribbon cable to simplify their connection. Connect one end of this cable to JF1 and the other end to the Control Panel printed circuit board, located just behind the system status LEDs in the chassis.

See the Connector Definitions section in this chapter for details and pin descriptions of JF1.

Figure 5-1. Front Control Panel Header Pins (JF1)

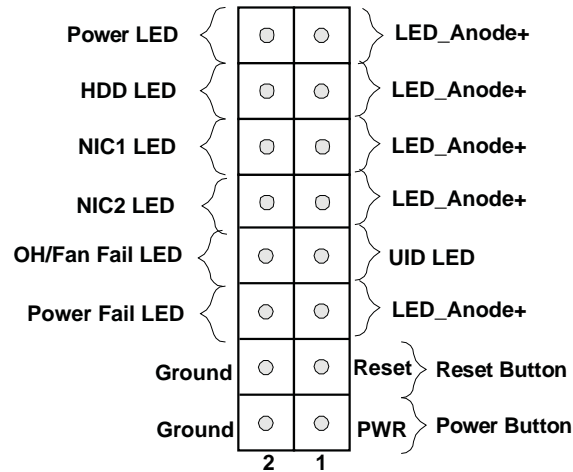

5-4 I/O Ports

The I/O ports are color coded in conformance with the PC 99 specification. See Figure 5-2 below for the colors and locations of the various I/O ports.

Figure 5-2. Rear Panel I/O Ports

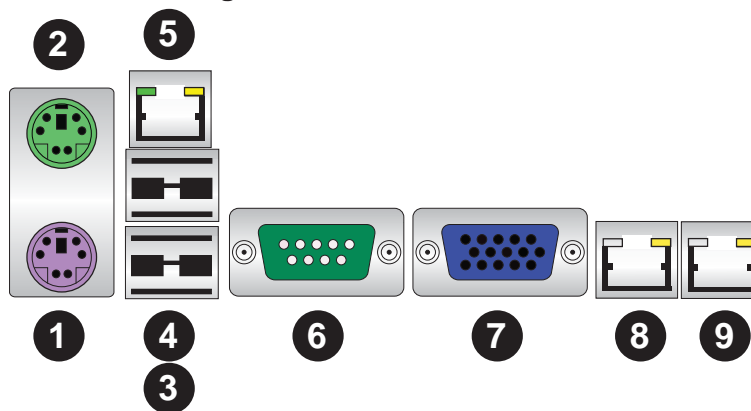

Backplane I/O Ports	
1. Keyboard (Purple)	6. COM 1
2. PS/2 Mouse (Green)	7. VGA
3. USB Port 0	8. LAN1
4. USB Port 1	9. LAN2
5. IPMI LAN	

5-5 Installing Memory

Note: Check the Supermicro web site for recommended memory modules.

CAUTION

Exercise extreme care when installing or removing DIMM modules to prevent any possible damage.

Installing DIMMs

1. Insert the desired number of DIMMs into the memory slots, starting with slots DIMM1A. Pay attention to the notch along the bottom of the module to prevent inserting the DIMM module incorrectly. See Figure 5-5.
2. Gently press down on the DIMM module until it snaps into place in the slot. Repeat fstep 1 to install to DIMM1B if needed.

Memory Support

The X9SCL-F supports up to 32GB of ECC unbuffered (UDIMM) DDR3-1333/1066 memory in four memory slots. Populating these slots with a pair of memory modules of the same type and same size will result in interleaved memory, which will improve memory performance. Please refer to the table below:

DDR3 Unbuffered ECC (UDIMM) Memory				
DIMM Slots per Channel	DIMMs Populated per Channel	DIMM Type	POR Speeds	Ranks per DIMM (any combination)
2	1	Unbuffered DDR3	1066, 1333	Single Rank, Dual Rank
2	2	Unbuffered DDR3	1066, 1333	Single Rank, Dual Rank

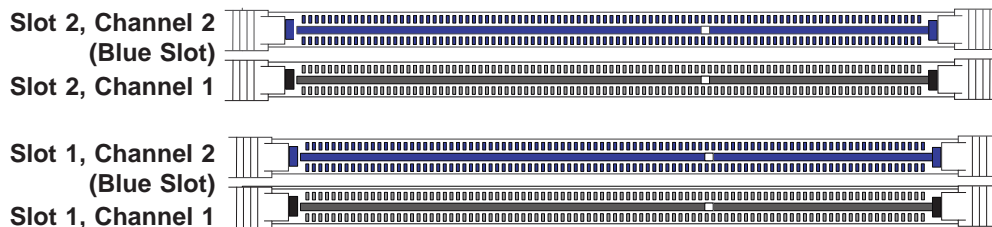
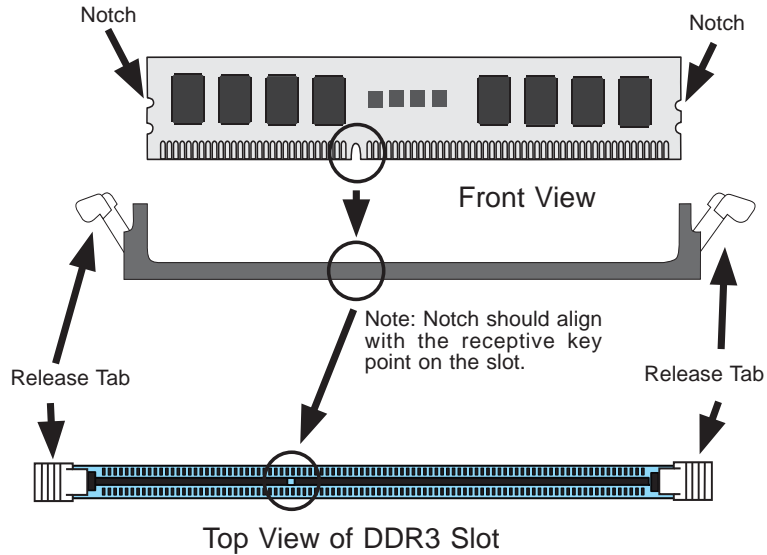

Figure 5-3. Installing DIMM into Slot

To Install: Insert module vertically and press down until it snaps into place. Pay attention to the alignment notch at the bottom.

To Remove: Use your thumbs to gently push the release tabs near both ends of the module. This should release it from the slot.



Note: Due to memory allocation to system devices, the amount of memory that remains available for operational use will be reduced when 4 GB of RAM is used. The reduction in memory availability is disproportional.

For Microsoft Windows users: Microsoft implemented a design change in the Windows XP with Service Pack 2 (SP2) and Windows Vista. This change is specific to the behavior of Physical Address Extension (PAE) mode which improves driver compatibility. For more information, please read the following article at Microsoft's Knowledge Base website at: <http://support.microsoft.com/kb/888137>.

Possible System Memory Allocation & Availability		
System Device	Size	Physical Memory Remaining (-Available) (4 GB Total System Memory)
Firmware Hub flash memory (System BIOS)	1 MB	3.99
Local APIC	4 KB	3.99
Area Reserved for the chipset	2 MB	3.99
I/O APIC (4 Kbytes)	4 KB	3.99
PCI Enumeration Area 1	256 MB	3.76
PCI Express (256 MB)	256 MB	3.51
PCI Enumeration Area 2 (if needed) -Aligned on 256-MB boundary-	512 MB	3.01
VGA Memory	16 MB	2.85
TSEG	1 MB	2.84
Memory available to OS and other applications		2.84

5-6 Adding PCI Cards

PCI Expansion Slots

One riser card is used to support a PCI expansion (add-on) card in the system. The SC813MTQ-350B chassis can accommodate one standard size (full height full length) PCI expansion card. When viewed from the chassis front, the card installs to the left rear of the system.

PCI Card Installation

Before installing a PCI add-on card, make sure it is supported by the riser card. Begin by releasing the locking tab that corresponds to the slot you wish to populate. Insert the expansion card into the riser card by pushing down with your thumbs evenly on both sides of the card.

PCI Slot/Card Configurations

Riser Card

RSC-RR1U-E8 (pre-installed)

Expansion card supported

1x PCI-E 2.0 x8 card

5-7 Motherboard Details

Figure 5-4. SUPER X9SCL-F Layout

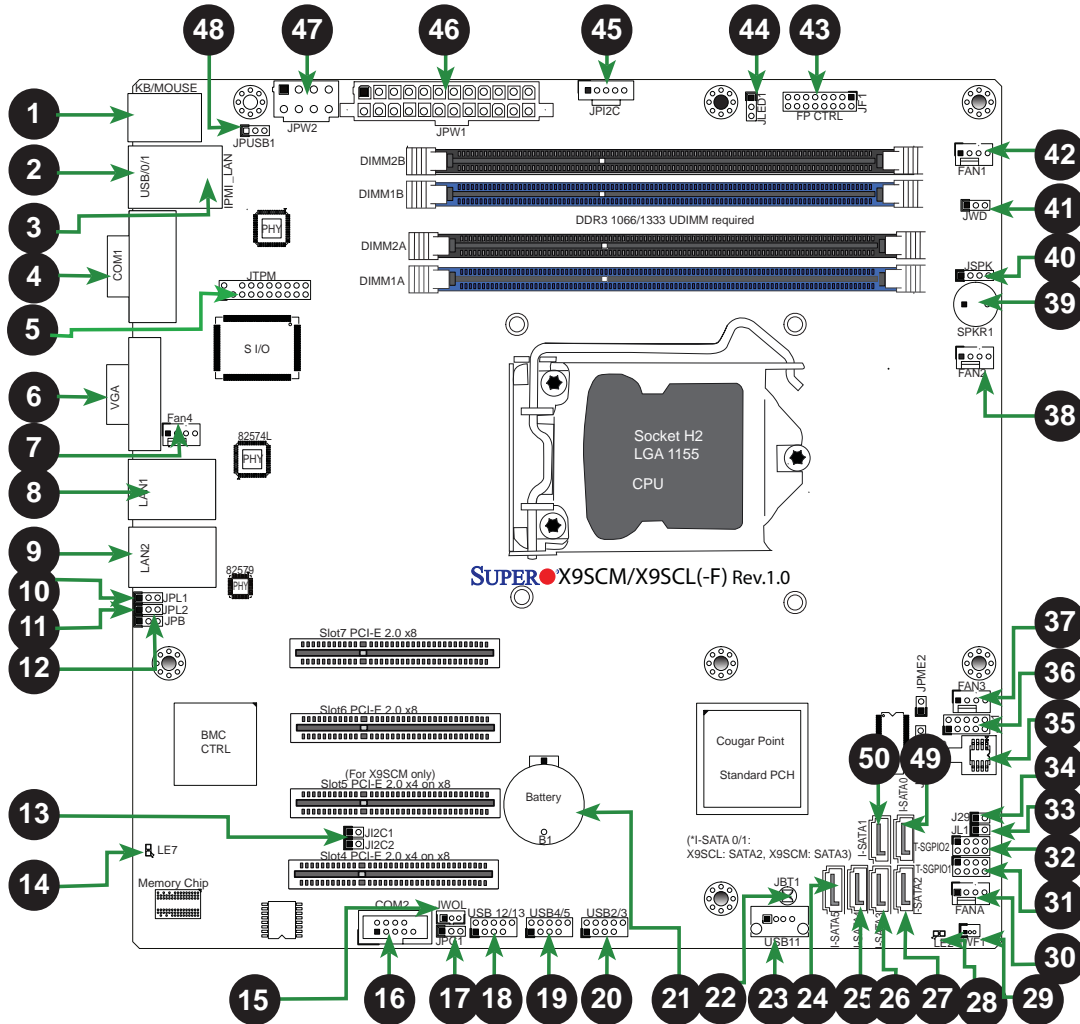

Jumpers			
Number	Jumper	Description	Default
34	J29	SPI Programming (internal use)	Closed (Normal)
22	JBT1	CMOS Clear	See Section 5-9
13	J12C1/J12C2	SMB to PCI Slots	See Section 5-9
12	JPB	BMC Enable	Pins 1-2 (Enabled)
17	JPG1	Onboard VGA Enable	Pins 1-2 (Enabled)
10,11	JPL1/JPL2	LAN1/LAN2 Enable	Pins 1-2 (Enabled)
48	JPUSB1	BP USB 0/1 Wake-Up Enable	Pins 1-2 (Enabled)
41	JWD	Watch Dog Timer Enable	Pins 1-2 (Reset)

Headers/Connectors		
Number	Connector	Description
21	B1	Onboard Battery
4,16	COM1/COM2	COM1/2 Serial Port/Header
35	BIOS	SPI BIOS
42,38,37,7,30	Fans 1~4, Fan A	System/CPU Fan Headers
36	J31	SPI Programming (internal use)
43	JF1	Front Panel Control Header
33	JL1	Chassis Intrusion Header
44	JLED1	Power LED Indicator Header
46	JPW1	24-pin ATX Main Power Connector
47	JPW2	+12V 8-pin CPU power Connector
1	KB/Mouse	Keyboard/Mouse Connectors
8,9,3	LAN1/LAN2, IPMI LAN	Gigabit (RJ45) Ports (LAN1/2), IPMI_LAN (F-models)
49,50,25-7,24	I-SATA 0/1	Serial ATA Ports 0/1/2/3/4/5
45	JPI ² C	PWR supply (I ² C) System Management Bus
40	JSPK	Speaker Header
5	JTPM	Trusted Platform Module (TPM) Header
29	JWF1	SATA DOM Power Connector
15	JWOL	Wake On LAN Header
39	SPKR1	Internal Speaker/Buzzer
31, 32	T-SGPIO-1/2	Serial Link General Purpose I/O 1/2 Headers (5V Gen1/Gen 2)
2	USB0/1	Backpanel USB 0/1
20,19,18	USB2/3, USB4/5, USB12/13	Front Accessible USB Headers
23	USB11	Front Accessible Type A USB Connector
6	VGA	Onboard Video Port

LED Indicators		
Number	LED	Description
14	LE7	IPMI Heartbeat LED (IPMI Active)
28	LE2	Onboard Standby PWR LED

5-8 Connector Definitions

ATX Power Connector

A 24-pin main power connector is located at JPW1. This power connector meet the SSI EPS 12V specification. See the table on the right for pin definitions.

ATX Power 24-pin Connector Pin Definitions (JPW1)			
Pin#	Definition	Pin #	Definition
13	+3.3V	1	+3.3V
14	-12V	2	+3.3V
15	COM	3	COM
16	PS_ON	4	+5V
17	COM	5	COM
18	COM	6	+5V
19	COM	7	COM
20	Res (NC)	8	PWR_OK
21	+5V	9	5VSB
22	+5V	10	+12V
23	+5V	11	+12V
24	COM	12	+3.3V

Processor Power Connector

In addition to the ATX main power, the 8-pin 12V power connector located at JPW2 is also required to provide power to the South Bridge, North Bridge and all VRMs. See the table on the right for pin definitions.

Processor Power Pin Definitions (JPW2)	
Pins	Definition
1 through 4	Ground
5 through 8	+12V

Power LED

The Power LED connection is located on pins 15 and 16 of JF1. Refer to the table on the right for pin definitions.

Power LED Pin Definitions (JF1)	
Pin#	Definition
15	+5V
16	Ground

HDD LED

The HDD LED connections are located on pins 13 and 14 of JF1. Attach a cable here to indicate HDD activity. See the table on the right for pin definitions.

HDD LED Pin Definitions (JF1)	
Pin#	Definition
13	+5V
14	HD Active

NIC1/NIC2 (LAN1/LAN2)

The NIC (Network Interface Controller) LED connection for LAN port 1 is located on pins 11 and 12 of JF1, and the LED connection for LAN Port 2 is on Pins 9 and 10. NIC1 LED and NIC2 LED are 2-pin NIC LED headers. Attach NIC LED cables to NIC1 LED and NIC2 LED to display network activities for LAN 1 and LAN2. Refer to the table on the right for pin definitions.

LAN1/LAN2 LED Pin Definitions (JF1)	
Pin#	Definition
9/11	Vcc
10/12	LAN Act

Overheat (OH)/Fan Fail/Front UID LED

Connect an LED cable to the Front UID and OH/Fan Fail connections on pins 7 and 8 of JF1 to display UID (Unit ID) signals or to provide advanced warnings for chassis overheat/fan failure. Refer to the table on the right for pin definitions.

OH/Fan Fail LED Pin Definitions (JF1)	
Pin#	Definition
7	Vcc/Blue UID LED
8	OH/Fan Fail LED

OH/Fan Fail Indicator Status	
State	Definition
Off	Normal
On	Overheat
Flash-ing	Fan Fail

Reset Button

The Reset Button connection is located on pins 3 and 4 of JF1. Attach it to a the hardware Reset Button on the computer case. Refer to the table on the right for pin definitions.

Reset Button Pin Definitions (JF1)	
Pin#	Definition
3	Reset
4	Ground

Power Button

The Power Button connection is located on pins 1 and 2 of JF1. Momentarily contacting both pins will power on/off the system. This button can also be configured to function as a suspend button (see BIOS Setup). To turn off the power in the suspend mode, press the button for at least 4 seconds. Refer to the table on the right for pin definitions.

Power Button Pin Definitions (JF1)	
Pin#	Definition
1	Signal
2	GND

Universal Serial Bus (USB)

Two Universal Serial Bus ports (USB 0/1) are located on the I/O backpanel and an additional six USB ports in three headers, USB2/3, 4/5, 12/13 provide front/back chassis access. USB 11 is a Type A USB connector. (USB cables are not included). See the tables on the right for pin definitions.

Back Panel USB0/1 Pin Definitions			
Pin#	Definition	Pin#	Definition
1	+5V	5	+5V
2	USB_PN1	6	USB_PN0
3	USB_PP1	7	USB_PP0
4	Ground	8	Ground

Front/Back Panel USB2/3, 11, 12/13 Pin Definitions			
USB 2/4/11/12		USB 3/5/13	
Pin #	Definition	Pin #	Definition
1	+5V	6	+5V
2	USB_PN2	7	USB_PN3
3	USB_PP2	8	USB_PP3
4	Ground	9	Ground
5	No Connection	10	Key

Serial Ports

The COM1 Port is located on the I/O backpanel. COM2 is a header located on the the motherboard. See the table on the right for pin definitions.

Serial Port Pin Definitions (COM1/COM2)			
Pin #	Definition	Pin #	Definition
1	CDC	6	DSR
2	RXD	7	RTS
3	TXD	8	CTS
4	DTR	9	RI
5	Ground	10	NC

Ethernet Ports

Two Ethernet ports (LAN1/LAN2) are located next to the VGA port on the I/O back panel. An IPMI Dedicated LAN port is also located above the USB0/1 ports on the X9SCL-F. This provides a dedicated network connection for IPMI 2.0 support. These ports accept RJ45 type connectors/cables.

LAN Port Pin Definitions			
Pin#	Definition	Pin#	Definition
1	GND	9	TD0+
2	Vcc19-LAN	10	TD0
3	TD3+	11	Link 100 LED
4	TD3-	12	Link 100 LED
5	TD2+-	13	3.3V
6	TD2-	14	Act LED
7	TD1+-	15	GND
8	TD1-	16	GND

NC = No connection

Fan Headers

The X9SCL-F has five fan headers (Fan1 ~ Fan4 and FanA). These are all 4-pin fan headers, however pins 1-3 are backward compatible with traditional 3-pin fans. A fan speed control setting in the BIOS (Hardware Monitoring section) allows the BIOS to automatically set fan speeds based on the system temperature. Refer to the table on the right for pin definitions.

Fan Header Pin Definitions	
Pin#	Definition
1	Ground (Black)
2	2.5A/+12V (Red)
3	Tachometer
4	PWM_Control

Note: Please use all 3-pin fans or all 4-pin fans on a motherboard. Do not mix 3-pin fans and 4-pin fans on the same board.

Chassis Intrusion

A Chassis Intrusion header is located at JL1 on the motherboard. Attach the appropriate cable from the chassis to inform you of a chassis intrusion when the chassis is opened.

Chassis Intrusion Pin Definitions	
Pin#	Definition
1	Intrusion Input
2	Ground

ATX PS/2 Keyboard and PS/2 Mouse Ports

The ATX PS/2 keyboard and the PS/2 mouse ports are located beside the USB ports. See the table on the right for pin definitions.

PS/2 Keyboard and Mouse Ports Pin Definitions	
Pin#	Definition
1	Data
2	NC
3	Ground
4	VCC
5	Clock
6	NC

External Speaker

On the JSPK header, pins 3~4 are used to activate the onboard (internal) speaker. Close pins 3~4 with a jumper to use the onboard speaker. If you wish to use an external speaker, attach the external speaker's cable to pins 1~4. See the table on the right for pin definitions.

Speaker Connector Pin Definitions	
Pin Setting	Definition
Pins 3~4	Internal Speaker
Pins1~4	External Speaker

Trusted Platform Module Header

This header is used to connect a Trusted Platform Module (TPM), available separately from a third-party vendor. A TPM is a security device that allows encryption and authentication of hard drives, disallowing access if the TPM associated with it is not installed in the system. See the table on the right for pin definitions.

Trusted Platform Module Header Pin Definitions			
Pin #	Definition	Pin #	Definition
1	LCLK	2	GND
3	LFRAME	4	No Pin
5	LRESET	6	VCC5
7	LAD3	8	LAD2
9	VCC3	10	LAD1
11	LAD0	12	GND
13	RSV0	14	RSV1
15	SB3V	16	SERIRQ
17	GND	18	CLKRUN
19	LPCPD	20	RSV2

Onboard Power LED

An onboard Power LED header is located at JLED. This Power LED header is connected to the Control Panel header (JF1) to indicate the status of system power. See the table on the right for pin definitions.

Onboard PWR LED Pin Definitions	
Pin#	Definition
1	VCC
2	No Connection
3	Connection to PWR LED in JF1

Power Supply I²C Connector

The Power Supply (I²C) connector is located at JPI²C on the motherboard. This connector monitors the status of the power supply, fan and system temperature. See the table on the right for pin definitions.

PWR Supply I ² C Pin Definitions	
Pin#	Definition
1	Clock
2	Data
3	PWR Fail
4	Ground
5	3.3V

Wake-On-LAN

The Wake-On-LAN header is located at JWOL on the motherboard. See the table on the right for pin definitions. (You must also have a LAN card with a Wake-On-LAN connector and cable to use this feature.)

Wake-On-LAN Pin Definitions (JWOL)	
Pin#	Definition
1	+5V Standby
2	Ground
3	Wake-up

T-SGPIO 0/1 Headers

Two T-SGPIO (Serial-Link General Purpose Input/Output) headers are located near the SATA connectors on the motherboard. These headers are used to communicate with the enclosure management chip in the system. See the table on the right for pin definitions. Refer to the board layout below for the locations of the headers.

Serial_Link-SGPIO Pin Definitions			
Pin#	Definition	Pin	Definition
1	NC	2	NC
3	Ground	4	DATA Out
5	Load	6	Ground
7	Clock	8	NC

DOM PWR Connector

A Disk On Module (DOM) Power Connector is located at JWF1. This connector is used to provide power to auxilliary flash memory media attached to a SATA port. See the table on the right for pin definitions.

DOM PWR Connector Pin Definitions	
Pin	Definition
1	5V
2	Ground
3	Ground

T-SGPIO 1/2 Headers

Two T-SGPIO (Serial-Link General Purpose Input/Output) headers are located near the SATA connectors on the motherboard. These headers are used to communicate with the enclosure management chip in the system. See the table on the right for pin definitions.

SGPIO Header Pin Definitions			
Pin#	Definition	Pin	Definition
2	NC	1	NC
4	Data Out	3	Ground
6	Ground	5	Load
8	NC	7	Clock

NC = No connection

5-9 Jumper Settings

Explanation of Jumpers

To modify the operation of the motherboard, jumpers can be used to choose between optional settings. Jumpers create shorts between two pins to change the function of the connector. Pin 1 is identified with a square solder pad on the printed circuit board. See the diagram at right for an example of jumping pins 1 and 2. Refer to the motherboard layout page for jumper locations.

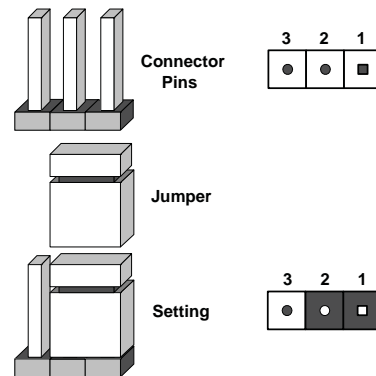

Note: On two-pin jumpers, "Closed" means the jumper is on and "Open" means the jumper is off the pins.

CMOS Clear

JBT1 is used to clear CMOS and will also clear any passwords. Instead of pins, this jumper consists of contact pads to prevent accidentally clearing the contents of CMOS.

To Clear CMOS

1. First power down the system and unplug the power cord(s).
2. With the power disconnected, short the CMOS pads with a metal object such as a small screwdriver.
3. Remove the screwdriver (or shorting device).
4. Reconnect the power cord(s) and power on the system.

Note: Do not use the PW ON connector to clear CMOS.

VGA Enable/Disable

JPG1 allows you to enable or disable the VGA port. The default position is on pins 1 and 2 to enable VGA. See the table on the right for jumper settings.

VGA Enable/Disable Jumper Settings (JPG1)	
Jumper Setting	Definition
Pins 1-2	Enabled
Pins 2-3	Disabled

PCI Slot SMB Enable

Use Jumpers JI²C1/JI²C2 to enable PCI SMB (System Management Bus) support to improve system management for the PCI slots. Default is disabled. See the table on the right for jumper settings.

PCI Slot SMB Enable/Disable Jumper Settings	
Jumper Setting	Definition
Closed	Enabled
Open (Default)	Disabled

LAN Port Enable/Disable

Use JPL1/JPL2 to enable or disable LAN Ports 1 and 2 on the motherboard. See the table on the right for jumper settings. The default setting is enabled.

LAN Port En/Disable Jumper Settings	
Pin#	Definition
1-2	Enabled
2-3	Disabled

USB Wake-Up

Use the JUSB1 jumper to wake your system by pressing a key on a USB keyboard or clicking USB mouse. This jumper is used together with the USB Wake-Up feature in the BIOS. Enable this jumper and the USB feature in the BIOS to wake-up your system via USB devices. The default setting is enabled.

USB Wake-up Jumper Settings	
Pin#	Definition
1-2	Enabled (Default)
2-3	Disabled

BMC Enable/Disable

JPB is used to enable or disable the BMC (Baseboard Management Control) chip and the onboard IPMI connection. This jumper is used together with the IPMI settings in the BIOS. The default position is on pins 1 and 2 to Enable BMC. See the table on the right for jumper settings.

BMC IPMI Enable/Disable Jumper Settings	
Settings	Definition
Pins 1-2	Enabled
Pins 2-3	Disabled

Watch Dog Enable

Watch Dog is a system monitor that can reboot the system when a software application hangs. Close pins 1-2 to reset the system if an application hangs. Close pins 2-3 to generate a non-maskable interrupt signal for the application that hangs. See the table on the right for jumper settings. Watch Dog must also be enabled in the BIOS.

Watch Dog Jumper Settings	
Jumper Setting	Definition
Pins 1-2	Reset (default)
Pins 2-3	NMI
Open	Disabled

5-10 Onboard Indicators

LAN1/LAN2 LEDs

The Ethernet ports (located beside the VGA port) have two LEDs. On each Gigabit LAN port, the yellow LED indicates activity when blinking while the other LED may be green, amber or off to indicate the speed of the connection. See the table on the right for the functions associated with the connection speed LED.

LAN LED Connection Speed Indicator	
LED State	Definition
Off	No connection or 10 Mb/s
Green	100 Mb/s
Amber	1 Gb/s

IPMI Dedicated LAN

In addition to the LAN ports, a dedicated IPMI LAN port is also included on the X9SCL-F. The yellow LED on the right indicates activity, while the green LED on the left indicates the speed of the connection. See the tables at right for more information.

IPMI LAN Link LED (Left) & Activity LED (Right)		
LED	Color	Definition
Link (left)	Green: Solid	100 Mbps
Activity (right)	Yellow: Blinking	Active

Onboard Standby Power LED

An Onboard Standby Power LED is located at LE2 on the motherboard. When LE2 is on, the AC power cable is connected. Make sure to disconnect the power cable before removing or installing any component.

Onboard Standby PWR LED	
LED State	Definition
Off	System Off
On	System on, or System off and PWR Cable Connected

IPMI Heartbeat LED

An IPMI Heartbeat LED is located at LE7. When LE7 blinks, the IPMI is functioning properly. Refer to the table on the right for details.

IPMI Heartbeat Indicator) LED	
LED	Definition
Link (left)	IPMI is ready for use

5-11 SATA Drive Connections

SATA Ports

Six Serial ATA (SATA) ports (I-SATA 0~5) are located on the motherboard. See the table on the right for pin definitions for the onboard SATA ports.

SATA Port Pin Definitions (SATA0 ~ SATA5)	
Pin #	Definition
1	Ground
2	TXP
3	TXN
4	Ground
5	RXN
6	RXP
7	Ground

5-12 Installing Drivers

After all the hardware and operating system have been installed, you need to install certain drivers. The necessary drivers are all included on the Supermicro CD that came packaged with your motherboard. After inserting this CD into your CD-ROM drive, the display shown in Figure 5-4 should appear. (If this display does not appear, click on the My Computer icon and then on the icon representing your CD-ROM drive. Finally, double click on the S "Setup" icon.)

Figure 5-4. Driver Installation Display Screen

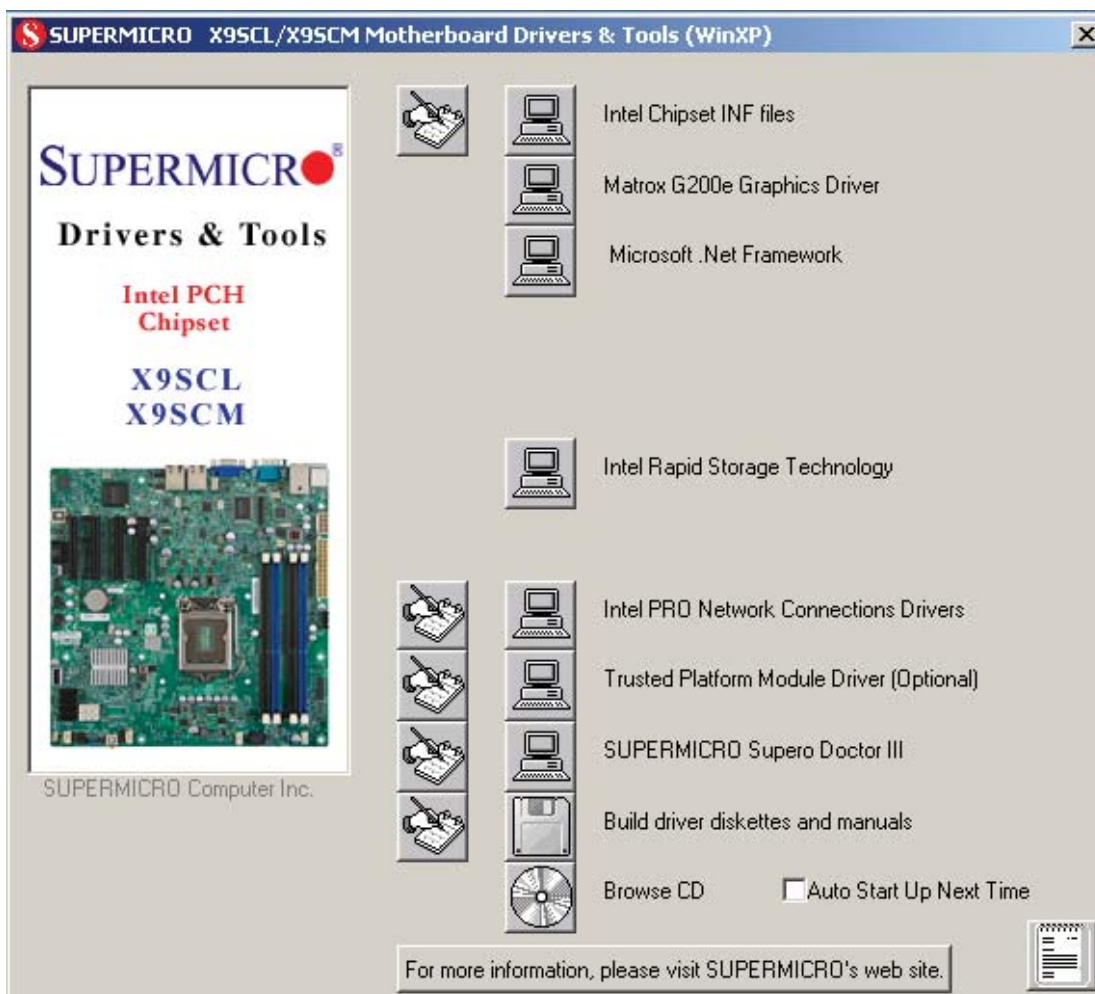

Click the icons showing a hand writing on paper to view the readme files for each item. Click the tabs to the right of these *in order from top to bottom* to install each item one at a time. **After installing each item, you must reboot the system before moving on to the next item on the list.** You should install everything here except for the SUPER Doctor utility, which is optional. The bottom icon with a CD on it allows you to view the entire contents of the CD.

SuperDoctor III

The SuperDoctor® III program is a Web base management tool that supports remote management capability. It includes Remote and Local Management tools. The local management is called SD III Client. The SuperDoctor III program included on the CD-ROM that came with your motherboard allows you to monitor the environment and operations of your system. SuperDoctor III displays crucial system information such as CPU temperature, system voltages and fan status. See the Figure below for a display of the SuperDoctor III interface.

Note: The default User Name and Password for SuperDoctor III is ADMIN / ADMIN.

Note: When SuperDoctor is first installed, it adopts the temperature threshold settings that have been set in BIOS. Any subsequent changes to these thresholds must be made within SuperDoctor, as the SuperDoctor settings override the BIOS settings. To set the BIOS temperature threshold settings again, you would first need to uninstall SuperDoctor.

SuperDoctor III Interface Display Screen (Health Information)



SuperDoctor III Interface Display Screen (Remote Control)

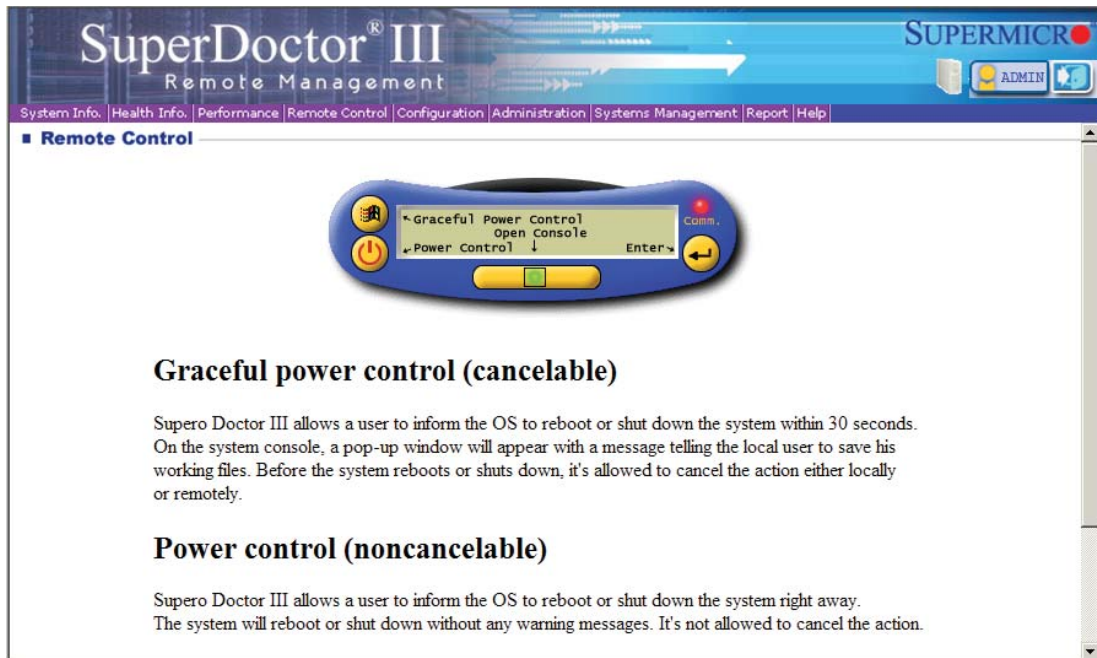

Note: The SuperDoctor III program and User's Manual can be downloaded from the Supermicro web site at <http://www.supermicro.com/products/accessories/software/SuperDoctorIII.cfm>.

For Linux, we recommend using SuperDoctor II.

Notes

Chapter 6

Advanced Chassis Setup

This chapter covers the steps required to install components and perform maintenance on the SC813MTQ chassis. For component installation, follow the steps in the order given to eliminate the most common problems encountered. If some steps are unnecessary, skip ahead to the step that follows.

Tools Required: The only tool you will need to install components and perform maintenance is a Philips screwdriver.

6-1 Static-Sensitive Devices

Electrostatic Discharge (ESD) can damage electronic components. To prevent damage to any printed circuit boards (PCBs), it is important to handle them very carefully. The following measures are generally sufficient to protect your equipment from ESD discharge.

Precautions

- Use a grounded wrist strap designed to prevent static discharge.
- Touch a grounded metal object before removing any board from its antistatic bag.
- Handle a board by its edges only; do not touch its components, peripheral chips, memory modules or gold contacts.
- When handling chips or modules, avoid touching their pins.
- Put the serverboard, add-on cards and peripherals back into their antistatic bags when not in use.
- For grounding purposes, make sure your computer chassis provides excellent conductivity between the power supply, the case, the mounting fasteners and the serverboard.

Unpacking

The serverboard is shipped in antistatic packaging to avoid static damage. When unpacking the board, make sure the person handling it is static protected.

Figure 6-1. Chassis Front View

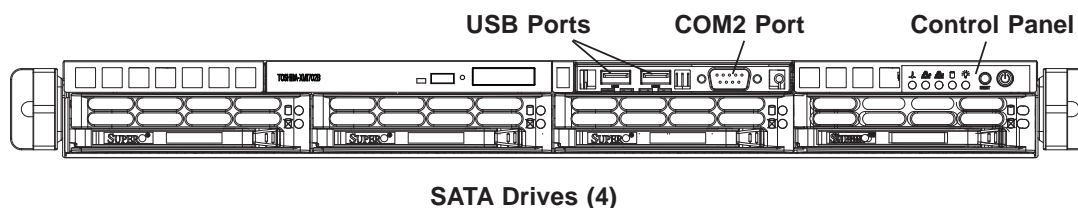
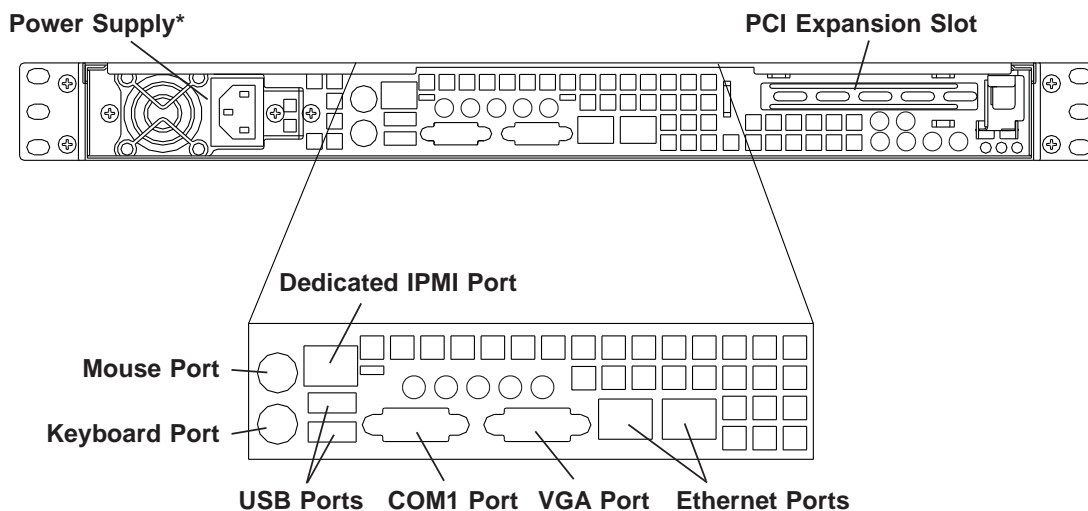

Figure 6-2. Chassis Rear View



*The 5017C-MTRF includes two power supplies for redundancy.

6-2 Control Panel

The control panel (located on the front of the chassis) must be connected to the JF1 connector on the serverboard to provide you with system control buttons and status indicators. These wires have been bundled together in a ribbon cable to simplify the connection.

The LEDs inform you of system status. See Chapter 3 for details on the LEDs and the control panel buttons. Details on JF1 can be found in Chapter 5.

6-3 System Fans

Four 4-cm high-performance fans provide the cooling for the SuperServer 5017C-MTF/5017C-MTRF. The chassis includes air seals under the fans and at the chassis cross section, which separates the drive bay area from the serverboard area of the chassis to promote better airflow. It is highly important that the air seal is properly installed and making a good seal in order for the cooling air to circulate properly through the chassis.

The fans can adjust their speed according to the heat level sensed in the system, which results in more efficient and quieter fan operation. Fan speed is controlled by a setting in BIOS.

System Fan Failure

If a fan fails, you will need to have it replaced with the same type. Contact your vendor or Supermicro for information on replacement fans.

6-4 Drive Bay Installation/Removal

Removing the Front Bezel

If your system has a front bezel (optional) attached to the chassis, you must first remove it to gain access to the drive bays. To remove the bezel, first unlock the front of the chassis then press the release knob (see Figure 6-3). Carefully remove the bezel with both hands. A filter located within the bezel can be removed for replacement/cleaning. It is recommended that you keep a maintenance log of filter cleaning/replacement, since its condition will affect the airflow throughout the whole system.

Figure 6-3. Removing the Front Bezel

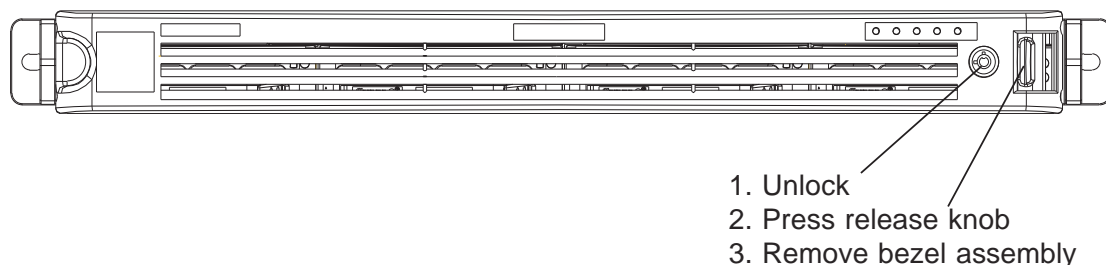

Accessing the Drive Bays

SATA Drives: Because of their hotswap capability, you do not need to access the inside of the chassis or power down the system to install or replace SATA drives. Proceed to the next step for instructions. **Note:** The operating system you use must have RAID support to enable the hot-swap capability of the drives.

DVD-ROM Drive: For installing/removing a DVD-ROM drive, you will need to gain access to the inside of the server by removing the top cover of the chassis. Proceed to the "DVD-ROM Drive Installation" section in this chapter for instructions. Note that only a "slim" DVD-ROM drive will fit into the 5017C-MTF/5017C-MTRF.

Note: A DVD drive does not come standard with the system.



Use caution when working around the SATA backplane. Do not touch the backplane with any metal objects and make sure no ribbon cables touch the backplane. Also, regardless of how many drives are installed, all four drive carriers must remain in the chassis to maintain proper airflow.



Enterprise level hard disk drives are recommended for use in Supermicro chassis and servers. For information on recommended HDDs, visit the Supermicro Web site at <http://www.supermicro.com/products/nfo/files/storage/SAS-1-CompList-110909.pdf>

SATA Drive Installation

Mounting a Drive in a Drive Carrier

The SATA drives are mounted in drive carriers to simplify their installation and removal from the chassis. These carriers also help promote proper airflow for the system. For this reason, even empty carriers without drives installed must remain in the chassis.

1. Install a new drive into the carrier with the printed circuit board side facing down so that the mounting holes align with those in the carrier.
2. Secure the drive to the carrier with six screws, as shown in Figure 6-4.

Installing/Removing SATA Drives

1. To remove a carrier, push the release button located beside the drive LEDs.
2. Swing the colored handle fully out and use it to pull the unit straight out (see Figure 6-5).

Note: There is no onboard RAID support for SATA drives.

Figure 6-4. Mounting a Drive in a Carrier

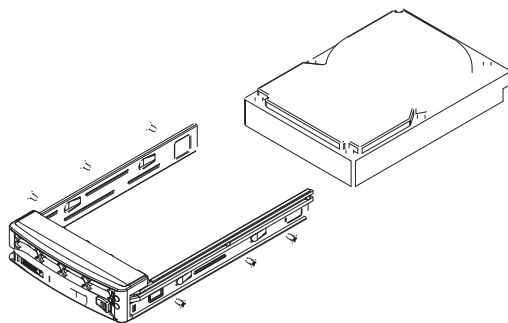

SATA Backplane

The SATA drives plug into a backplane that provides power, drive ID and bus termination. A RAID controller can be used with the backplane to provide data security for the drives. The backplane is already preconfigured, so there are no jumpers or switches present on it.

Figure 6-5. Removing a Drive from the Server

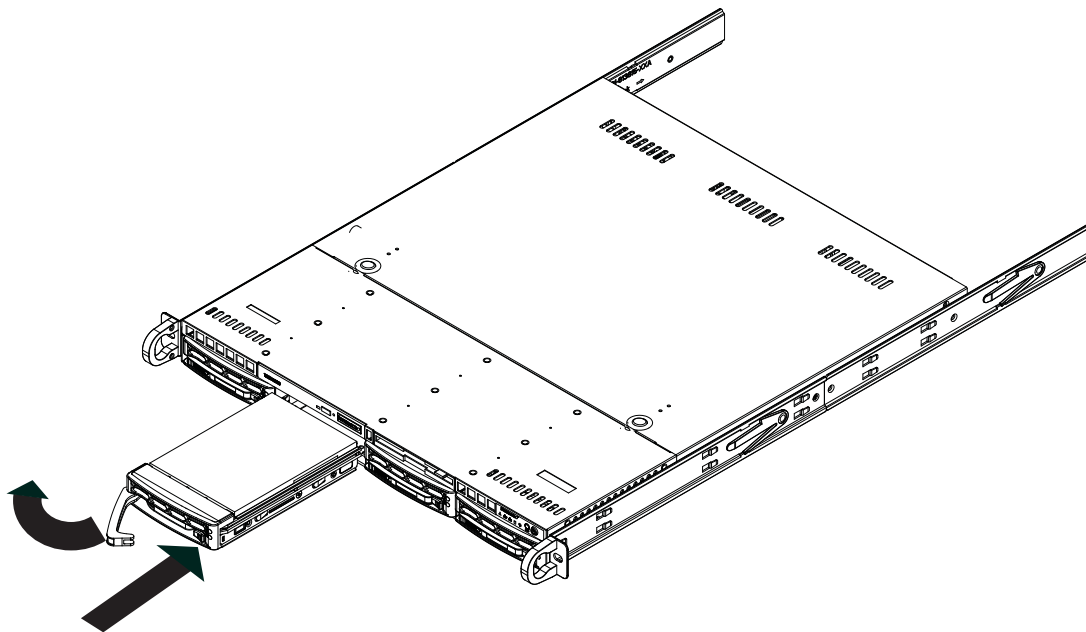

DVD-ROM Drive Installation

The top cover of the chassis must be opened to gain full access to the DVD-ROM drive bay. The 5017C-MTF/5017C-MTRF accomodates only slim DVD-ROM drives. Side mounting brackets are needed to mount a slim DVD-ROM drive into the 5017C-MTF/5017C-MTRF server.You must power down the system before installing or removing a DVD-ROM drive. Note that the DVD drive is optional; it does not come already installed in the system but may be installed by the user.

Removing the Chassis Cover

1. Grasp the two handles on either side and pull the unit straight out until it locks (you will hear a "click").
2. Depress the two buttons on the top of the chassis to release the top cover and at the same time, push the cover away from you until it stops. You can then lift the top cover from the chassis to gain full access to the inside of the server.

Removing/Installing a Drive

1. With the chassis cover removed, unplug the power and data cables from the drive.
2. Locate the locking tab at the rear of the drive. It will be on the left side of the drive when viewed from the front of the chassis.
3. Pull the tab away from the drive and push the drive unit out the front of the chassis.
4. Add a new drive by following this procedure in reverse order. You may hear a faint *click* of the locking tab when the drive is fully inserted.
5. Remember to reconnect the data and power cables to the drive before replacing the chassis cover and restoring power to the system.

6-5 Power Supply

The SuperServer 5017C-MTF has a single 350 watt power supply. This power supply has the capability of operating at 100 - 240 input volts. Depress the main power button on the front of the chassis and then unplug the AC power cord to completely remove power from the system before removing the power supply.

Power Supply Failure

If the power supply unit fails, the system will shut down and you will need to replace the power supply unit. Replacement units can be ordered directly from Supermicro (see contact information in Chapter 1).

Replacing the Power Supply

To replace a power supply, you must first remove the top chassis cover. Follow the procedure on the previous page.

1. First unplug the power cord from the system.
2. To remove the failed power unit, remove the two screws on the back of the power supply, which secure it to the chassis. You can then lift the unit straight out of the chassis.
3. Replace the failed unit with another unit of the same wattage. It is highly recommended to replace it with the exact same power supply.
4. Carefully insert the new unit into position in the chassis and secure it with the two screws at the rear of the unit.
5. Before reconnecting the power cord, make sure the power switch on the power supply is in the off position. Then reconnect the power cord, replace the chassis top cover and push the unit back into the rack.
6. Finish by turning the power switch on the power supply on, and then depress the power button on the front of the system.

The SuperServer 5017C-MTRF has a 400 watt redundant power supply consisting of two power modules. Each power supply module has an auto-switching capability, which enables it to automatically sense and operate at a 100V - 240V input voltage.

If either of the two power supply modules fail, the other module will take the full load and allow the system to continue operation without interruption. The PWR Fail LED will illuminate and remain on until the failed unit has been replaced. Replacement units can be ordered directly from Supermicro. The power supply units have a hot-swap capability, meaning you can replace the failed unit without powering down the system.

Removing the Power Supply

1. First unplug the AC power cord from the failed power supply module.
2. To remove the failed power unit, remove the two screws on the back of the power supply, which secure it to the chassis. You can then lift the unit straight out of the chassis.
3. Replace the failed unit with another unit of the same wattage. You should replace it with the exact same power supply (same model number).
4. Carefully insert the new unit into position in the chassis and secure it with the two screws at the rear of the unit.
5. Before reconnecting the power cord, make sure the power switch on the power supply is in the off position. Then reconnect the power cord, replace the chassis top cover and push the unit back into the rack.

Chapter 7

BIOS

7-1 Introduction

This chapter describes the AMI BIOS Setup Utility for the X9SCL-F. The AMI ROM BIOS is stored in a Flash EEPROM and can be easily updated. This chapter describes the basic navigation of the AMI BIOS Setup Utility setup screens.

Note: For instructions on BIOS recovery, please refer to the instruction guide posted at <http://www.supermicro.com/support/manuals/>.



Starting BIOS Setup Utility

To enter the AMI BIOS Setup Utility screens, press the <Delete> key while the system is booting up.

Note: In most cases, the <Delete> key is used to invoke the AMI BIOS setup screen. There are a few cases when other keys are used, such as <F1>, <F2>, etc.



Each main BIOS menu option is described in this manual. The Main BIOS setup menu screen has two main frames. The left frame displays all the options that can be configured. Grayed-out options cannot be configured. Options in blue can be configured by the user. The right frame displays the key legend. Above the key legend is an area reserved for a text message. When an option is selected in the left frame, it is highlighted in white. Often a text message will accompany it. (**Note:** the AMI BIOS has default text messages built in. Supermicro retains the option to include, omit, or change any of these text messages.)

The AMI BIOS Setup Utility uses a key-based navigation system called "hot keys". Most of the AMI BIOS setup utility "hot keys" can be used at any time during the setup navigation process. These keys include <F1>, <F10>, <Enter>, <ESC>, arrow keys, etc.

Note: Options printed in **Bold** are default settings.



How To Change the Configuration Data

The configuration data that determines the system parameters may be changed by entering the AMI BIOS Setup utility. This Setup utility can be accessed by pressing at the appropriate time during system boot.

How to Start the Setup Utility

Normally, the only visible Power-On Self-Test (POST) routine is the memory test. As the memory is being tested, press the <Delete> key to enter the main menu of the AMI BIOS Setup Utility. From the main menu, you can access the other setup screens. An AMI BIOS identification string is displayed at the left bottom corner of the screen, below the copyright message.



Warning! Do not upgrade the BIOS unless your system has a BIOS-related issue. Flashing the wrong BIOS can cause irreparable damage to the system. In no event shall Supermicro be liable for direct, indirect, special, incidental, or consequential damages arising from a BIOS update. If you have to update the BIOS, do not shut down or reset the system while the BIOS is updating. This is to avoid possible boot failure.

7-2 Main Setup

When you first enter the AMI BIOS Setup Utility, you will enter the Main setup screen. You can always return to the Main setup screen by selecting the Main tab on the top of the screen. The Main BIOS Setup screen is shown below.

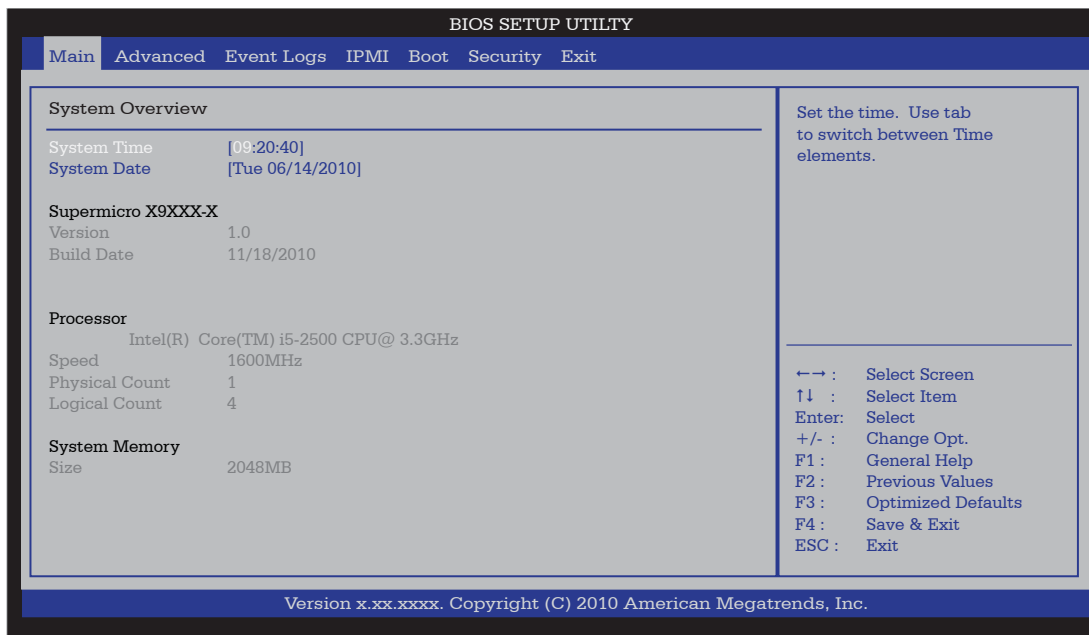

System Overview: The following BIOS information will be displayed:

System Time/System Date

Use this option to change the system time and date. Highlight *System Time* or *System Date* using the arrow keys. Enter new values through the keyboard. Press the <Tab> key or the arrow keys to move between fields. The date must be entered in Day MM/DD/YY format. The time is entered in HH:MM:SS format. (**Note:** The time is in the 24-hour format. For example, 5:30 P.M. appears as 17:30:00.)

Supermicro X9SCM/X9SCM-F/X9SCL/X9SCL-F

Version

Build Date

Processor

The AMI BIOS will automatically display the status of processor as shown below:

Processor

Speed

Physical Count

Logical Count

System Memory

This displays the size of memory available in the system:

Size

7-3 Advanced Setup Configurations

Use the arrow keys to select Boot Setup and hit <Enter> to access the submenu items:

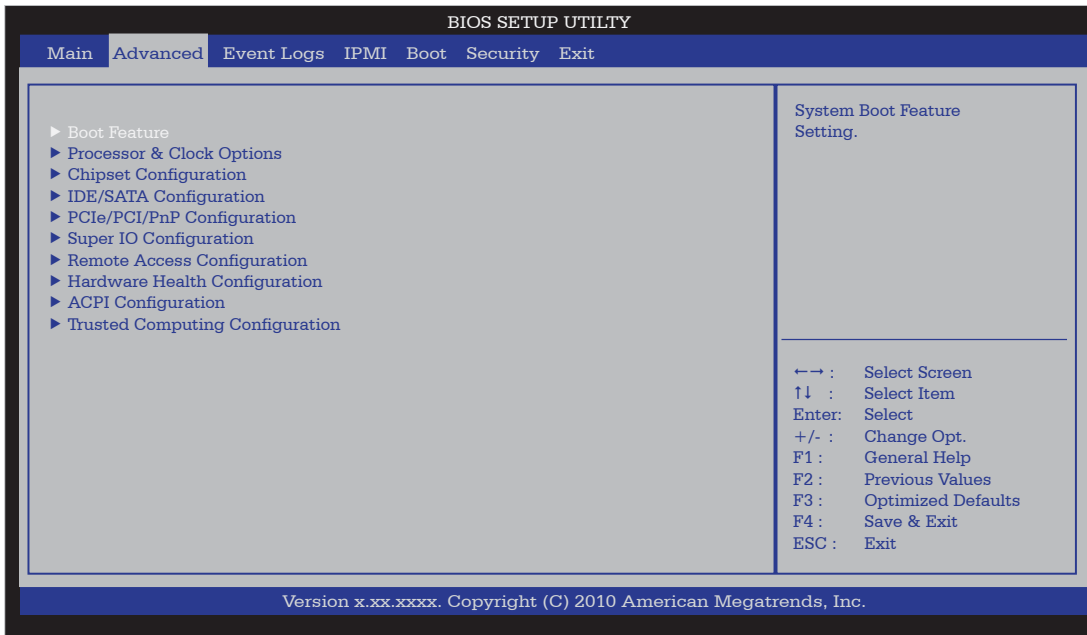

►BOOT Feature

Quiet Boot

This option allows the bootup screen options to be modified between POST messages or the OEM logo. Select Disabled to display the POST messages. Select Enabled to display the OEM logo instead of the normal POST messages. The options are **Enabled** and Disabled.

AddOn ROM Display Mode

This sets the display mode for Option ROM. The options are **Force BIOS** and Keep Current.

Bootup Num-Lock

This feature selects the Power-on state for Numlock key. The options are Off and **On**.

Wait For 'F1' If Error

This forces the system to wait until the 'F1' key is pressed if an error occurs. The options are Disabled and **Enabled**.

Interrupt 19 Capture

Interrupt 19 is the software interrupt that handles the boot disk function. When this item is set to Enabled, the ROM BIOS of the host adaptors will "capture" Interrupt

19 at boot and allow the drives that are attached to these host adaptors to function as bootable disks. If this item is set to Disabled, the ROM BIOS of the host adaptors will not capture Interrupt 19, and the drives attached to these adaptors will not function as bootable devices. The options are **Enabled** and Disabled.

Watch Dog Function

If enabled, the Watch Dog Timer will allow the system to reboot when it is inactive for more than 5 minutes. The options are Enabled and **Disabled**.

Power Button Function

This feature controls how the system shuts down when the power button is pressed. Select 4-Second Override to force the user to press and hold the Power Button for 4 seconds before the system turns off. Select Instant Off if you want the system to instantly power off when the Power Button is pressed. The options are 4 Second Override and **Instant Off**.

Restore on AC Power Loss

Use this feature to set the power state after a power outage. Select Power-Off for the system power to remain off after a power loss. Select Power-On for the system power to be turned on after a power loss. Select Last State to allow the system to resume its last state before a power loss. The options are Power-On, Power-Off and **Last State**.

VFC

This item enables or disables the VESA Feature Connector (VFC) option. The options are **Enabled** and Disabled.

Deep Sx

Select Enabled to enable Deep Sleep State support. The settings are Enabled and **Disabled**.

►Processor & Clock Options



Warning: Take Caution when changing the Advanced settings. An incorrect value, a very high DRAM frequency or incorrect DRAM timing may cause system to become unstable. When this occurs, revert to the default setting.

Hardware Prefetcher (Available when supported by the CPU)

If set to Enabled, the hardware pre fetcher will pre fetch streams of data and instructions from the main memory to the L2 cache in the forward or backward manner to improve CPU performance. The options are Disabled and **Enabled**.

Adjacent Cache Line Prefetch (Available when supported by the CPU)

The CPU fetches the cache line for 64 bytes if this option is set to Disabled. The CPU fetches both cache lines for 128 bytes as comprised if **Enabled**.

Intel® Virtualization Technology (Available when supported by the CPU)

Select Enabled to use the feature of Virtualization Technology to allow one platform to run multiple operating systems and applications in independent partitions, creating multiple "virtual" systems in one physical computer. The options are **Enabled** and Disabled. **Note:** If there is any change to this setting, you will need to power off and restart the system for the change to take effect. Please refer to Intel's web site for detailed information.

Execute-Disable Bit Capability (Available when supported by the OS and the CPU)

Set to Enabled to enable the Execute Disable Bit which will allow the processor to designate areas in the system memory where an application code can execute and where it cannot, thus preventing a worm or a virus from flooding illegal codes to overwhelm the processor or damage the system during an attack. The default is **Enabled**. (Refer to Intel and Microsoft Web Sites for more information.)

Intel® AES-NI

Set to Enabled to use the processor's Advanced Encryption Standard (AES) feature. The options are Enabled and **Disabled**.

Intel® Hyper Threading Technology

Set to Enabled to use the processor's Hyper Threading Technology feature. The options are **Enabled** and Disabled.

Active Processor Cores

Set to Enabled to use a processor's Second Core and beyond. (Please refer to Intel's web site for more information.) The options are **All**, 1, 2 and 3.

Power Technology

This feature determines what power-saving scheme the motherboard uses. The options are Disabled, Energy Efficient and Custom. If Custom is selected, the following options become available:

EIST

EIST (Enhanced Intel SpeedStep Technology) allows the system to automatically adjust processor voltage and core frequency in an effort to reduce power consumption and heat dissipation. **Please refer to Intel's web site for detailed information.** The options are **Disabled** and Enabled.

P-STATE Coordination

This feature selects the type of coordination for the P-State of the processor. P-State is a processor operational state that reduces the processor's voltage and frequency. This makes the processor more energy efficient, resulting in further gains. The options are **HW_ALL**, **SW_ALL** and **SW-ANY**.

CPU C3 Report, CPU C6 Report

This BIOS feature enables or disables C3 (ACPI C2) or C6 (ACPI C3) reporting to the operating system. The options are **Disabled** and **Enabled**.

C-State package limit setting

If set to Auto, the AMI BIOS will automatically set the limit on the C-State package register. The options are **C0**, **C1**, **C6**, **C7** and **No Limit**.

►Intel® Turbo Boost Technology (Available if Intel® EIST technology is Enabled)

Turbo Mode

This feature allows processor cores to run faster than marked frequency in specific conditions. The options are **Disabled** and **Enabled**.

Long duration power limit - this is the processor power consumption limit (in Watts) during a long duration time window.

Long duration maintained - this is the time in milliseconds where the Long Duration Power Limit is maintained.

Short duration power limit - During Turbo Mode, the system may exceed the processor's default power setting and exceed the Short Duration Power limit. By increasing this value, the processor can provide better performance for a short duration.

►Chipset Configuration

WARNING: Setting the wrong values in the following sections may cause the system to malfunction.

►CPU Bridge Configuration

This item displays the current CPU Revision, Current CPU1 Memory Frequency, Memory Type and Memory Reference Code Revision.

Memory Frequency

This feature allows the user to select the memory speed. Under normal conditions, please set this to Auto. The options are **Auto**, **Force DDR-800**, **Force DDR-1067**, **Force DDR-1333**, and **Force DDR-1600**.

►North Bridge Configuration

This item displays the current North Bridge Revision.

VT-d

Select Enabled to enable Intel's Virtualization Technology support for Direct I/O VT-d by reporting the I/O device assignments to VMM through the DMAR ACPI Tables. This feature offers fully-protected I/O resource-sharing across the Intel platforms, providing the user with greater reliability, security and availability in networking and data-sharing. The settings are Enabled and **Disabled**.

Active State Power Management

Select Enabled to start Active-State Power Management for signal transactions between L0 and L1 Links on the PCI Express Bus. This maximizes power-saving and transaction speed. The options are Enabled and **Disabled**.

PCIe Maximum Payload Size

This feature selects the setting for the PCIe maximum payload size. The options are **Auto**, 128 Bytes, 256 Bytes, 512 Bytes, 1024 Bytes, 2048 Bytes, and 4096 Bytes.

PCI Express Port

This feature enables or disables the PCI Express port. The options are Disabled, Enabled and **Auto**.

PEG Force Gen1

This feature forces Gen1 support on the PCI Express Graphics (PEG) port. The options are **Disabled**, and Enabled.

Detect Non-Compliant Device

This feature enables or disables the detection of a non-compliant device that is attached to the PCI Express Graphics (PEG) port. The options are **Disabled**, and Enabled.

►South Bridge Configuration

This item displays the current South Bridge Revision.

GbE Controller

Select Enabled to enable the onboard gigabit Ethernet controller. The settings are **Enabled** and Disabled.

Wake on LAN from S5

Select Enabled to enable the capability to 'wake-up' the system from the S5 power state (Soft Off State) through the Ethernet controller. The settings are **Enabled** and Disabled.

Legacy USB Support

This feature enables support for legacy USB devices. Select Auto to disable legacy support if USB devices are not present. Select Disable to have USB devices available only for EFI applications. The options are **Enabled**, Disabled and Auto.

BIOS EHCI Hand-Off

This item is for Operating Systems that does not support Enhanced Host Controller Interface (EHCI) hand-off. When enabled, EHCI ownership change will be claimed by the EHCI driver. The settings are **Enabled** and Disabled.

►IDE/SATA Configuration

When this submenu is selected, the AMI BIOS automatically detects the presence of the IDE Devices and displays the following items:

SATA Mode

This item selects the mode for the installed drives. The options are Disabled, IDE Mode, **AHCI Mode** and RAID Mode.

IDE Mode

The following items are displayed when IDE Mode is selected:

Serial-ATA Controller 0~1

This feature is used to activate/deactivate the SATA controller, and sets the compatibility mode. The options are Enhanced and **Compatible**. The default of Serial-ATA Controller 1 is **Enhanced**.

SATA Port0~Port5

This item displays the information detected on the installed SATA drives on the particular SATA port.

AHCI Mode

The following items are displayed when AHCI Mode is selected:

Aggressive Link Power Management

This feature Enables or Disables Aggressive Link Power Management support for Cougar Point B0 stepping and later. The options are **Enabled** and **Disabled**.

SATA Port0~Port5

This item displays the information detected on the installed SATA drives on the particular SATA port.

Staggered Spin Up

Set this item to Enabled to enable Staggered Spin-up support. The options are Enabled and **Disabled**.

External SATA Port

Set this item to Enabled to enable eSATA support. The options are Enabled and **Disabled**.

Hot Plug

Set this item to Enabled to enable hot-plugging. The options are Enabled and **Disabled**.

RAID Mode

The following items are displayed when RAID Mode is selected:

SATA Port0~Port5

This item displays the information detected on the installed SATA drives on the particular SATA port.

Hot Plug

Set this item to Enabled to enable hot-plugging. The options are Enabled and **Disabled**.

►PCIe/PCI/PnP Configuration

This feature allows the user to set the PCI/PnP configurations for the following items:

PCI ROM Priority

In case of multiple Option ROMs (Legacy and EFI-compatible), this feature specifies what ROM to launch. The options are **Legacy ROM** and EFI Compatible ROM.

PCI Latency Timer

This feature sets the latency Timer of each PCI device installed on a PCI bus. Select 64 to set the PCI latency to 64 PCI clock cycles. The options are 32, **64**, 96, 128, 160, 192, 224 and 248.

SR-IOV Support

Single Root I/O Virtualization (SR-IOV) is a specification that allows a PCIe device to appear as multiple physical devices to the system. The options are **Disabled** and Enabled.

PCI-E Slot 4, 5, 6, & 7 OPROM

Use this feature to enable or disable PCI slot Option ROMs. The options are Disabled and **Enabled**.

Onboard LAN Option ROM Select

This feature selects whether to load the iSCSI or PXE onboard LAN option ROM. The options are iSCSI and **PXE**.

Load Onboard LAN1 Option ROM/Load Onboard LAN2 Option ROM

This feature is to enable or disable the onboard option ROMs. The options are **Disabled** and Enabled.

Boot Graphics Adapter Priority

Use the feature to select the graphics controller to be used as the primary boot device. The options are Offboard VGA and **Onboard VGA**.

►Super IO Device Configuration

Serial Port 1 / Serial Port 2

Select Enabled to enable the onboard serial port. The options are **Enabled** and Disabled.

Serial Port1 Settings/ Serial Port2 Settings

This option specifies the base I/O port address and the Interrupt Request address of Serial Port 1 and Serial Port 2. Select Disabled to prevent the serial port from accessing any system resources. When this option is set to Disabled, the serial port physically becomes unavailable. Select 3F8/IRQ4 to allow the serial port to use 3F8 as its I/O port address and IRQ 4 for the interrupt address. The options for Serial Port1 are Disabled, **3F8/IRQ4**, 3E8/IRQ4, 2F8/IRQ3 and 2E8/IRQ3. The options for Serial Port2 are Disabled, 3F8/IRQ4, 3E8/IRQ4, **2F8/IRQ3**, and 2E8/IRQ3.

Serial Port 2 Mode

Use this feature to configure Serial Port 2 mode. The options are **Normal**, IrDA and ASK IR. IrDA (Infrared Data) is an industry standard for remote control devices. ASK IR (Amplitude Shifted Keying Infrared) is a protocol compatible with Sharp® branded PDAs and other infrared devices.

► Remote Access Configuration

COM0/COM1/SOL Console Redirection

Use this feature to enable console redirection for COM0 and COM1 ports. The options are **Enabled** and Disabled. The default for all ports are Disabled.

► Console Redirection Settings

Configure the following options for the Console Redirection Settings. The most common settings are set as default:

Terminal Type : Select **ANSI**, VT100, VT100+, or VT-UTF8

Bits per Second (BPS): 9600, 19200, 57600, or **115200**

Data Bits: **8** or 7

Parity: **None**, Even, Odd, Mark, or Space

Stop Bits: **1** or 2

Flow Control: **None** or Hardware RTS/CTS

Recorder Mode: **Disabled** or Enabled

Resolution 100x31: **Disabled** or Enabled

Legacy OS Redirection Resolution: **80x24** or 80x25

Serial Port for Out-of-Band Management / Windows Emergency Management Services (EMS)

Use this feature to enable console redirection. The options are **Enabled** and Disabled. The default is Disabled.

► Console Redirection Settings

Configure the following options for the Console Redirection Settings. The most common settings are set as default:

Out-of-Band Mgmt Port: **COM1**, COM2, SOL, COM4

Terminal Type : Select ANSI, VT100, VT100+, or **VT-UTF8**

Bits per Second (BPS): 9600, 19200, 57600, or **115200**

Data Bits: **8** or 7

Parity: **None**, Even, Odd, Mark, or Space

Stop Bits: **1** or 2

► Hardware Health Configuration

Fan Speed Control Mode

This feature allows the user to decide how the system controls the speeds of the onboard fans. The CPU temperature and the fan speed are correlative. When the CPU on-die temperature increases, the fan speed will also increase for effective system cooling. Select "Full Speed" to allow the onboard fans to run at full speed (of 100% Pulse Width Modulation Duty Cycle) for maximum cooling. This setting is recommended for special system configuration or debugging. Select "Standard" for the onboard fans to run at 50% of the Initial PWM Cycle in order to balance the needs between system cooling and power saving. This setting is recommended for regular systems with normal hardware configurations. Select "Optimal" for the onboard fans to run at 30% of the Initial PWM Cycle for best power efficiency and maximum quietness. The options are Full Speed (@100% of PWM Cycle), **Standard** (@50% of PWM Cycle), and Optimal (@30% of PWM Cycle).

CPU Temperature Display Mode

This feature displays the CPU temperature detected by DTS (i.e., +34°C) or temperature status in text ("Low", "Medium" or "High"). The options are **Text Mode** or DTS.

If Text Mode is selected, the CPU Temperature Display Mode will show the CPU temperature status as follows:

Low – This level is considered as the 'normal' operating state. The CPU temperature is well below the CPU 'Temperature Tolerance'. The motherboard fans and CPU will run normally as configured in the BIOS (Fan Speed Control).

User intervention: No action required.

Medium – The processor is running warmer. This is a 'precautionary' level and generally means that there may be factors contributing to this condition, but the CPU is still within its normal operating state and below the CPU 'Temperature Tolerance'. The motherboard fans and CPU will run normally as configured in the BIOS. The fans may adjust to a faster speed depending on the Fan Speed Control settings.

User intervention: No action is required. However, consider checking the CPU fans and the chassis ventilation for blockage.

High – The processor is running hot. This is a 'caution' level since the CPU's 'Temperature Tolerance' has been reached (or has been exceeded) and may activate an overheat alarm:

The information provided above is for your reference only. For more information on thermal management, please refer to Intel's Web site at www.Intel.com.

Fan1 ~ Fan4, FanA Reading

This feature displays the fan speed readings from fan interfaces Fan1 through Fan4 and FanA.

12V, VDIMM, 5VCC, -12V, AVCC, 3.3VCC, VSB, VBAT

This feature displays the current voltages of the above voltage monitors.

►ACPI Configuration

Use this feature to configure Advanced Configuration and Power Interface (ACPI) power management settings for your system.

High Performance Event Timers

Select Enabled to activate the High Performance Event Timer (HPET) that produces periodic interrupts at a much higher frequency than a Real-time Clock (RTC) does in synchronizing multimedia streams, providing smooth playback and reducing the dependency on other timestamp calculation devices, such as an x86 RDTSC Instruction embedded in the CPU. The High Performance Event Timer is used to replace the 8254 Programmable Interval Timer. The options are **Enabled** and Disabled.

Suspend Mode

This setting allows you to configure the ACPI (Advanced Configuration and Power Interface) sleep state for your system when it is in the Suspend mode. The options are Suspend Disabled, S1 (POS), and **S3 (STR)**. S3 (STR) is the deepest sleep state in these options.

NUMA Support

This feature Enables the Non-Uniform Memory Access ACPI support. The options are **Enabled** and Disabled.

WHEA Support

This feature Enables the Windows Hardware Error Architecture (WHEA) support for the Windows 2008 operating system (and later versions). The options are **Enabled** and Disabled.

7-4 Event Logs

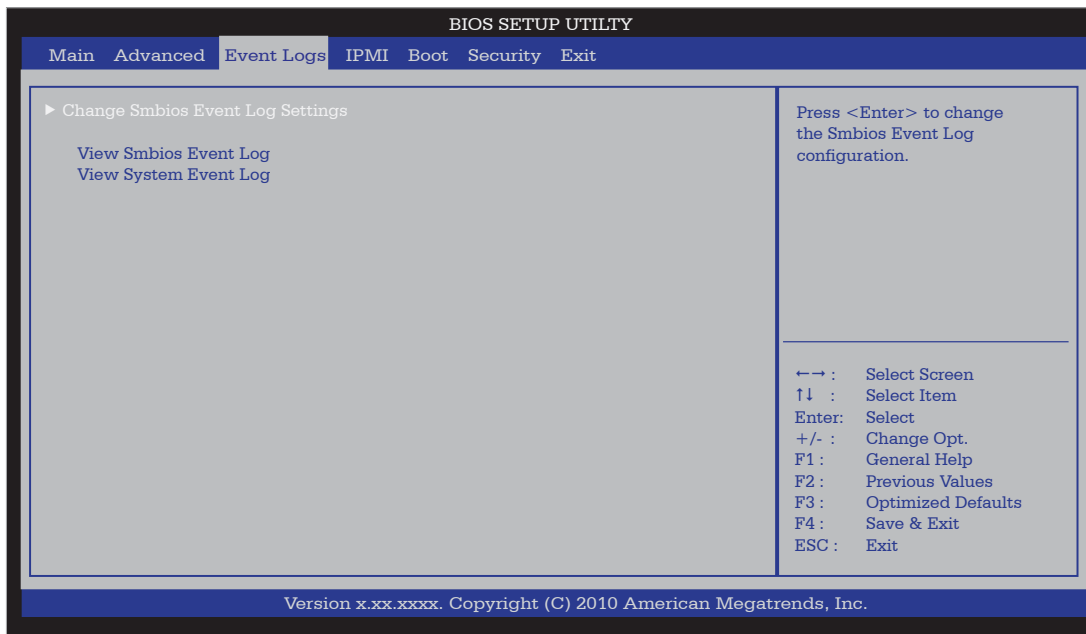

Smbios Event Log

Change this item to enable or disable all features of the Smbios Event Logging during boot. The options are **Enabled** and Disabled.

Erase Event Log

This option erases all logged events. The options are **No**, Yes, Next reset and Yes, Every reset.

When Log is Full

This option automatically clears the Event Log memory of all messages when it is full. The options are **Do Nothing** and Erase Immediately.

MECI

The Multiple Event Count Increment (MECI) counter counts the number of occurrences a duplicate event must happen before the MECI counter is incremented. This is a numeric value.

METW

The Multiple Event Time Window (METW) defines number of minutes must pass between duplicate log events before MECI is incremented. This is in minutes, from 0 to 99.

7-5 IPMI Configuration

Intelligent Platform Management Interface (IPMI) is a set of common interfaces that IT administrators can use to monitor system health and to manage the system as a whole. For more information on the IPMI specifications, please visit Intel's website at www.intel.com.

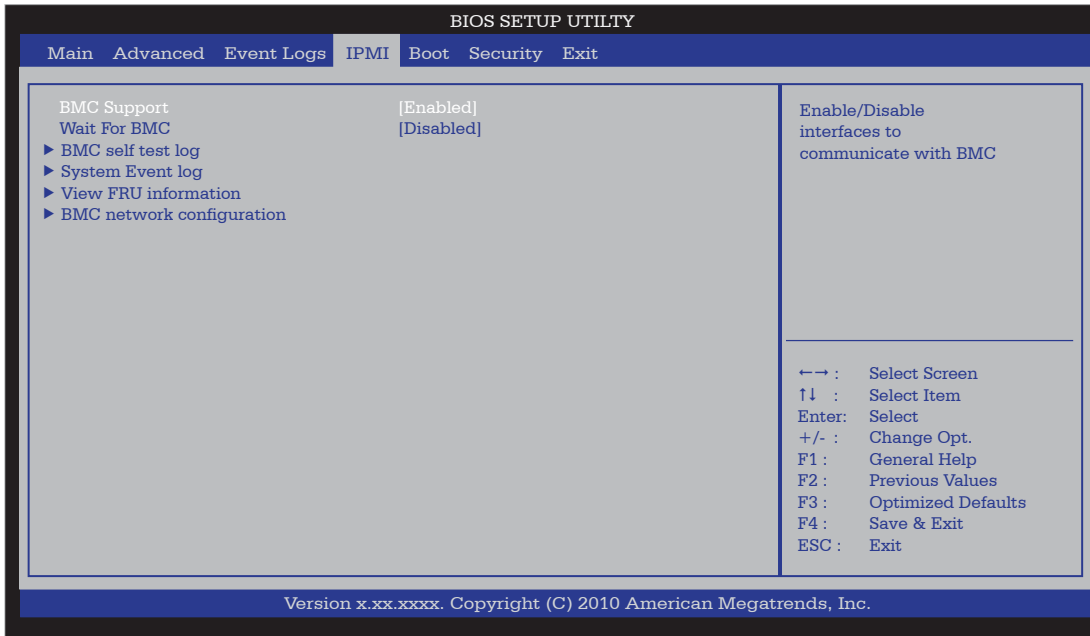

BMC Support

This feature enables or disables the installed Baseboard Management Controller (BMC) on the motherboard. The options are **Enabled** and Disabled.

Wait For BMC

If enabled, the system will wait for a BMC response after the AC power is turned on. It takes around 30 seconds to initialize Host to BMC interfaces. The options are **Disabled** and Enabled.

▶BMC Self Test Log

This feature logs any BMC messages returned during a BMC self-test. It shows the total number of entries and will allow the viewing of each event by scrolling down.

Erase Log - Select **Yes, On every reset** or No.

When Log is Full - Select **Clear Log** or Do Not Log Anymore.

▶System Event Log

This feature is used to change the System Event Log (SEL) configuration.

SEL Components - Change this item to enable or disable all features of System Event Logging. The options are Enabled and Disabled. When Enabled, the following can be configured:

Erase SEL - This option erases all logged SEL events. The options are No, Yes, On Next reset and Yes, On Every reset.

When SEL Full

This option automatically clears the System Event Log memory of all messages when it is full. The options are **Do Nothing** and Erase Immediately.

Log EFI Status Codes

This option enables or disables the logging of Extensible Firmware Interface (EFI) status codes. The options are Disabled, **Both**, Error Code and Progress Code.

►View FRU Information

This is an informational item which displays the information pertaining to this motherboard (FRU - Field Replaceable Unit).

►BMC Network Configuration

Set this feature to configure the IPMI LAN adapter with a network address.

Configuration Source

This feature selects whether the IP address, Subnet Mask and Gateway Address are automatically assigned by the network's DHCP server (Dynamic Host and Configuration Protocol) "Dynamic" or manually entered by the user "Static". If Static is selected, the IP Address, Subnet Mask and Gateway Address must be manually entered below. The options are Static, Dynamic and **Do Nothing**. The following items are displayed when Static is selected:

Station IP Address - Enter the IP address for this machine. This should be in decimal and in dotted quad form (i.e., 192.168.10.253). The value of each three-digit number separated by dots should not exceed 255.

Subnet Mask - Subnet masks tell the network which subnet this machine belongs to. The value of each three-digit number separated by dots should not exceed 255.

Station MAC Address - MAC addresses are 6 two-digit hexadecimal numbers (Base 16, 0 ~ 9, A, B, C, D, E, F) separated by dots (i.e., 00.30.48.D0.D4.60).

Router IP Address - Enter the Gateway or Router address this machine will use (i.e., 192.168.10.1).

Router MAC Address - Enter the MAC address of the Router or Gateway (only if needed).

7-6 Boot Settings

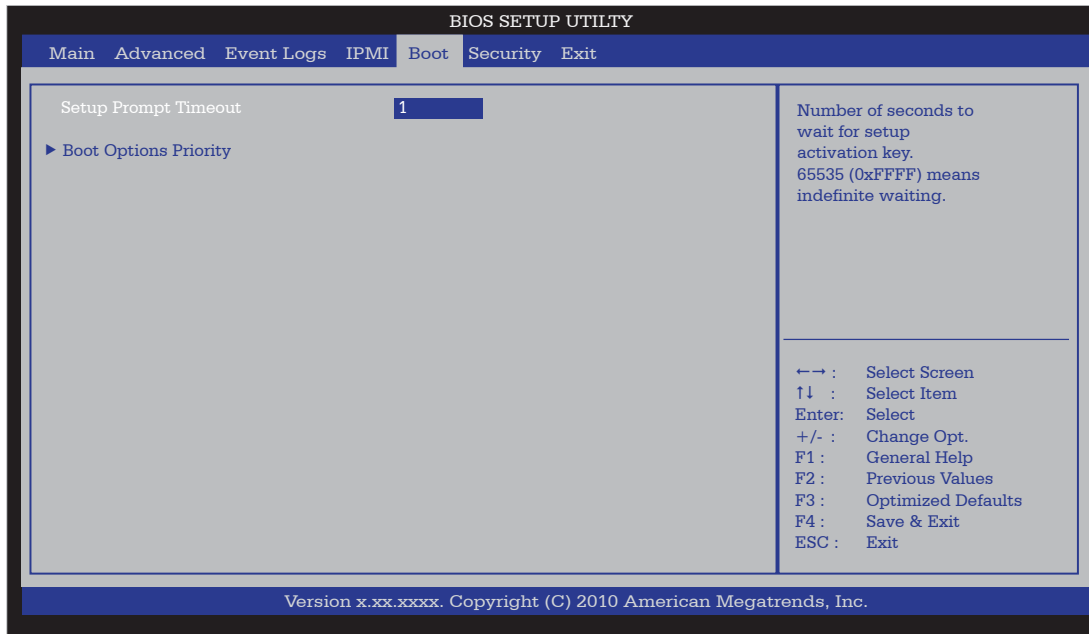

Use this feature to configure Boot Settings:

► Boot Options Priority

This feature allows the user to specify which devices are boot devices and the order of priority from which the systems boots from during startup.

Boot Option #1, Boot option #2, Boot Option #3, etc

The settings are **Built-in EFI Shell**, [any detected boot device] and Disabled.

7-7 Security Settings

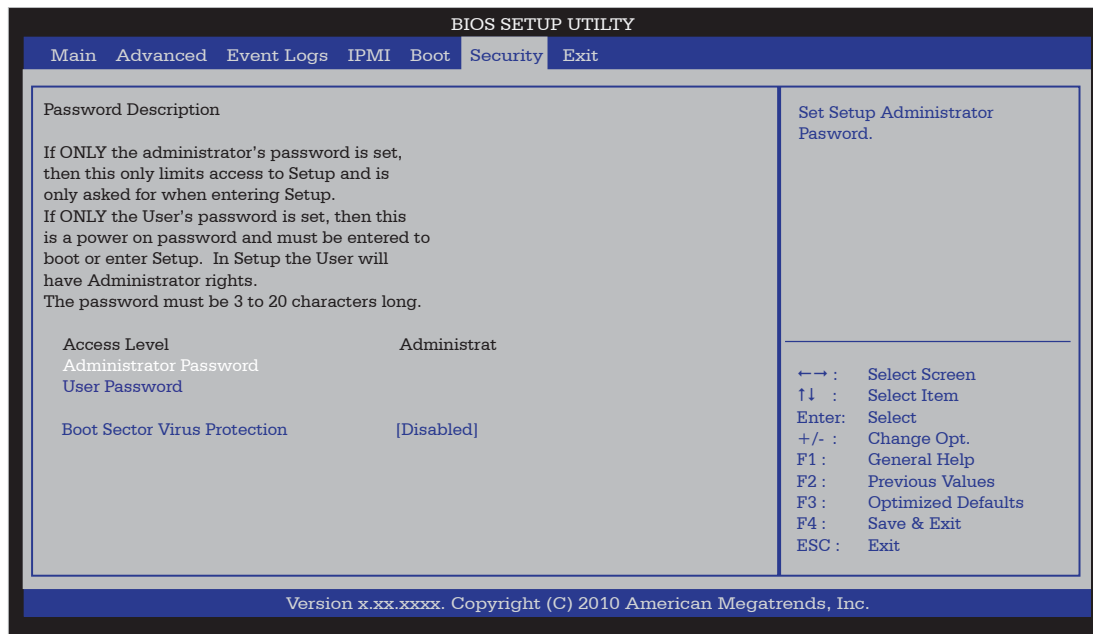

- If the Administrator password is defined ONLY - this controls access to the BIOS setup ONLY.
- If the User's password is defined ONLY - this password will need to be entered during each system startup or boot, and will also have Administrator rights in the setup.
- Passwords must be at least 3 and up to 20 characters long.

Administrator Password

Press Enter to create a new, or change an existing Administrator password.

User Password:

Press Enter to create a new, or change an existing User password.

Boot Sector Virus Protection

When Enabled, the BIOS displays a warning when any program (or virus) issues a Disk Format command or attempts to write to the boot sector of the hard disk drive. The options are Enabled and **Disabled**.

7-8 Exit Options

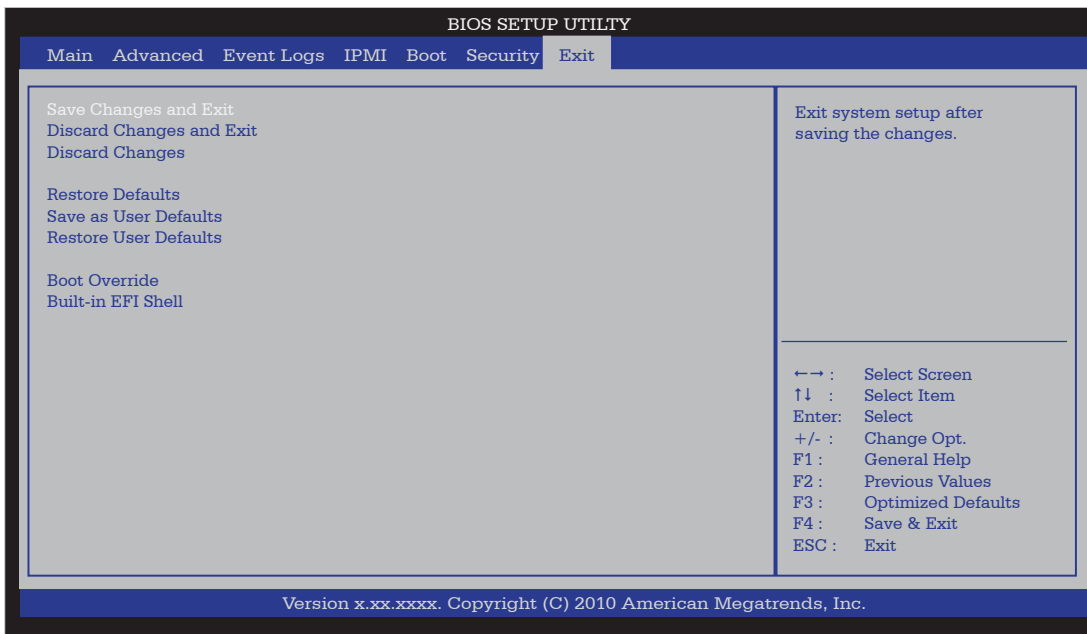

Select the Exit tab from the BIOS Setup Utility screen to enter the Exit BIOS Setup screen.

Save Changes and Exit

When you have completed the system configuration changes, select this option to leave the BIOS Setup Utility and reboot the computer, so the new system configuration parameters can take effect. Select Save Changes and Exit from the Exit menu and press <Enter>.

Discard Changes and Exit

Select this option to quit the BIOS Setup without making any permanent changes to the system configuration, and reboot the computer. Select Discard Changes and Exit from the Exit menu and press <Enter>.

Discard Changes

Select this option and press <Enter> to discard all the changes and return to the AMI BIOS Utility Program.

Restore Defaults

To set this feature, select Restore Defaults from the Exit menu and press <Enter>. These are factory settings designed for maximum system stability, but not for maximum performance.

Save As User Defaults

To set this feature, select Save as User Defaults from the Exit menu and press <Enter>. This enables the user to save any changes to the BIOS setup for future use

Restore User Defaults

To set this feature, select Restore User Defaults from the Exit menu and press <Enter>. Use this feature to retrieve user-defined settings that were saved previously.

Boot Override

Set this feature to override a previously defined boot device. The available devices will be listed below.

Notes

Appendix A

BIOS Error Beep Codes

During the POST (Power-On Self-Test) routines, which are performed each time the system is powered on, errors may occur.

Non-fatal errors are those which, in most cases, allow the system to continue with bootup. The error messages normally appear on the screen.

Fatal errors will not allow the system to continue to bootup. If a fatal error occurs, you should consult with your system manufacturer for possible repairs.

These fatal errors are usually communicated through a series of audible beeps. The numbers on the fatal error list correspond to the number of beeps for the corresponding error.

A-1 BIOS Error Beep Codes

BIOS Error Beep Codes		
Beep Code/LED	Error Message	Description
1 beep	Refresh	Circuits have been reset. (Ready to power up)
5 short beeps + 1 long beep	Memory error	No memory detected in the system
8 beeps	Display memory read/write error	Video adapter missing or with faulty memory
OH LED On	System OH	System Overheat

Notes

Appendix B

System Specifications

Processors

Single Intel® Xeon® E3-1200 Series processor or a Core™ i3-2100 Series processor in an LGA1155 socket

Note: Please refer to our web site for a complete listing of supported processors.

Chipset

Intel C202

BIOS

64 Mb SPI AMI® Flash

Memory Capacity

Four DIMM sockets supporting up to 32 GB of unbuffered DDR3-1333/1066 memory

See the memory section in Chapter 5 for details.

SATA Controller

Intel on-chip controller for six-port Serial ATA, RAID 0, 1 5 and 10 supported (RAID 5 not supported with Linux OS, Windows only)

SATA Drive Bays

Four hot-swap drive bays to house four SATA or hard drives

Expansion Slots

Riser card for one PCI-E 2.0 x8 add-on card

Serverboard

X9SCL-F (Micro ATX form factor)

Dimensions: 9.6 x 9.6 in (244 x 244 mm)

Chassis

SC813MTQ Form Factor: 1U rackmount

Dimensions: (WxHxD) 17.2 x 1.7 x 19.85 in. (437 x 43 x 504 mm)

Weight

Gross Weight: 38 lbs. (17.3 kg.)

System Cooling

Four 4-cm high performance fans

System Input Requirements

AC Input Voltage: 100-240V AC auto-range

Rated Input Current: 4.2A (100V) to 1.8A (240V)

Rated Input Frequency: 50 to 60 Hz

Power Supply

5017C-MTF:

Rated Output Power: 350W (Part# PWS-351-1H)

Rated Output Voltages: +3.3V (15A), +5V (18A), +12V (29A), -12V (.5A),
+5Vsb (3A)

5017C-MTRF:

Rated Output Power: 400W (Part# PWS-351-1H)

Rated Output Voltages: +3.3V (15A), +5V (18A), +12V (29A), -12V (.5A),
+5Vsb (3A)

Operating Environment

Operating Temperature: 10° to 35° C (50° to 95° F)

Non-operating Temperature: -40° to 70° C (-40° to 158° F)

Operating Relative Humidity: 8% to 90% (non-condensing)

Non-operating Relative Humidity: 5 to 95% (non-condensing)

Regulatory Compliance

Electromagnetic Emissions:

FCC Class A, EN 55022 Class A, EN 61000-3-2/-3-3, CISPR 22 Class A

Electromagnetic Immunity:

EN 55024/CISPR 24, (EN 61000-4-2, EN 61000-4-3, EN 61000-4-4, EN 61000-4-5, EN 61000-4-6, EN 61000-4-8, EN 61000-4-11)

Safety:

EN 60950/IEC 60950-Compliant, UL Listed (USA), CUL Listed (Canada), TUV Certified (Germany), CE Marking (Europe)

California Best Management Practices Regulations for Perchlorate Materials:

This Perchlorate warning applies only to products containing CR (Manganese Dioxide) Lithium coin cells. "Perchlorate Material-special handling may apply. See www.dtsc.ca.gov/hazardouswaste/perchlorate"

Disclaimer (continued from front)

The products sold by Supermicro are not intended for and will not be used in life support systems, medical equipment, nuclear facilities or systems, aircraft, aircraft devices, aircraft/emergency communication devices or other critical systems whose failure to perform be reasonably expected to result in significant injury or loss of life or catastrophic property damage. Accordingly, Supermicro disclaims any and all liability, and should buyer use or sell such products for use in such ultra-hazardous applications, it does so entirely at its own risk. Furthermore, buyer agrees to fully indemnify, defend and hold Supermicro harmless for and against any and all claims, demands, actions, litigation, and proceedings of any kind arising out of or related to such ultra-hazardous use or sale.

Notes

Free Manuals Download Website

<http://myh66.com>

<http://usermanuals.us>

<http://www.somanuals.com>

<http://www.4manuals.cc>

<http://www.manual-lib.com>

<http://www.404manual.com>

<http://www.luxmanual.com>

<http://aubethermostatmanual.com>

Golf course search by state

<http://golfingnear.com>

Email search by domain

<http://emailbydomain.com>

Auto manuals search

<http://auto.somanuals.com>

TV manuals search

<http://tv.somanuals.com>