

SHARP®

MODEL: DX-B350P
DX-B450P

LASER PRINTER User's Guide

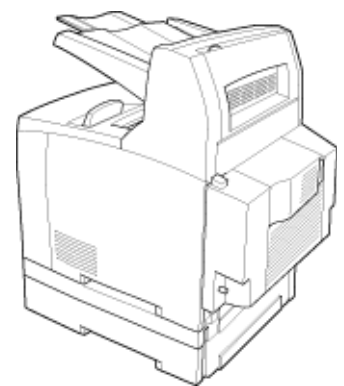

Contents

1 Introduction.....	1-1
Conventions	1-1
Safety Notes	1-2
Printer Orientation.....	1-2
2 Getting to Know Your Printer.....	2-1
Components.....	2-1
Front View	2-1
Rear View	2-2
Internal Components	2-3
Turning the Printer On and Off.....	2-4
Turning the Printer On	2-4
Turning the Printer Off.....	2-4
Available Printer Drivers	2-4
Paper Usage.....	2-5
Paper Sizes	2-5
Custom Sizes	2-6
Paper Types.....	2-6
Printing Transparencies.....	2-7
Printing Envelopes	2-8
Printing Labels.....	2-8
Available Paper	2-9
Unusable Paper	2-11
Loading Paper	2-11
Loading Paper Larger Than A4/Letter Size In The Paper Tray	2-14
Replacing the Toner Cartridge.....	2-15
Power Save Mode.....	2-17
Understanding Printing Options	2-17
3 Operator Panel	3-1
Operator Panel Features	3-1
LCD Display	3-1
LED Indicators.....	3-2
Push buttons	3-2
Navigating the Operator Panel Menus	3-3
Sample Navigation	3-3
Printing a Configuration Summary	3-4
Panel Lock.....	3-4
Operator Panel Menus	3-5
Job Library Menu.....	3-5
Job Accounting Menu	3-5
Paper Menu	3-6
Interface Menu	3-8
PS Menu.....	3-13
PCL Menu.....	3-13
System Menu	3-15
Quality Menu	3-16
Functions Menu.....	3-16
FLASH/Disk/CF Menu.....	3-17
Date/Time Menu.....	3-17
Status Information	3-18
Understanding Page Counters	3-20

4 Windows Operations	4-1
Installing PCL5e and PostScript 3 Drivers	4-1
Setting Default Values	4-2
Printing a Test Page	4-4
Cancelling Printing	4-5
Cancelling a Print Job at the Printer	4-5
Cancelling Print Jobs at the Computer	4-5
Accessing the Driver from an Application	4-6
Navigating the Printer Properties Window	4-7
Saved Settings	4-7
Main Tab	4-8
Selecting Number of Copies	4-8
Collating Copies	4-9
Setting Image Orientation	4-9
Output Destination	4-9
Document Style (2-Sided Printing/Duplex)	4-9
Poster Printing	4-10
Multiple Pages to Single Sheet (N-up)	4-11
Finishing	4-11
Job Offset	4-12
Paper Tab	4-12
Source	4-12
Printing on Special Paper	4-12
Selecting Paper Size	4-13
Custom Size Paper	4-13
Cover Sheet Selection	4-13
Zoom Settings	4-14
Auto Tray Change	4-14
Media Check	4-14
Skip Blank Pages	4-15
Manual Feed	4-16
Advanced Tab	4-16
Manual Adjustments	4-16
Quality	4-16
Overlay Options	4-16
Create Overlays	4-16
Using Overlays	4-17
Font Substitution	4-17
Job Handling Tab	4-18
Job Accounting	4-18
Job Accounting Fields	4-19
Job Retention and Storage	4-20
Hold Only	4-21
Hold After Print	4-21
Sample Print	4-21
Password/PIN	4-21
Watermark Tab	4-21
5 Macintosh Operations	5-1
Installing the Driver	5-1
Accessing the Driver	5-3
Navigating the Driver	5-4
6 Embedded Web Server	6-1
Accessing the EWS	6-1
Navigating the EWS	6-2
7 Networking	7-1

Protocols	7-1
Initial Setting of the Printer's IP Address	7-1
Setting the IP Address through DHCP	7-1
Setting the Network Configuration Manually	7-2
Setting the IP Address through the Embedded Web Server	7-2
Configuring the Driver	7-2
Printer Network Configuration	7-3
Network Protocol Configuration	7-3
I/O Port Configuration	7-3
Hub Link Speed/Duplex Configuration	7-3
Notifications	7-4
IP Filtering	7-4
IPv6 Implementation	7-5
Specifications	7-5
Operational Information	7-5
SNMP	7-5
Supported Object Identifiers	7-6
Traps	7-6
Hewlett Packard Web Jet Administrative Compatibility	7-6
SNMP Alerts	7-6
8 Accessories	8-1
Tray module (A4/Letter, 550 sheets)	8-2
Installing/Uninstalling the Tray Module	8-2
Checking the contents of the tray module package	8-2
Installing the Tray Module	8-3
Uninstalling the Tray Module	8-7
Paper trays	8-10
Paper tray (A4/Letter, 550 sheets)	8-10
Duplex module	8-10
Installing the Duplex Module	8-11
Uninstalling the Duplex Module	8-12
Offset Catch Tray	8-14
Installing/Uninstalling the Offset Catch Tray	8-15
Installing the Offset Catch Tray	8-15
Uninstalling the Offset Catch Tray	8-18
Memory Expansion Module	8-20
Hard Disk Drive	8-21
Compact Flash (CF) Card	8-22
9 Troubleshooting	9-1
Poor Print Quality	9-2
Paper Is Output Blank or All Black	9-2
Printout Is Faded, Stained, Missing, Wrinkled, or Blurred	9-2
No Power	9-6
Cannot Print	9-6
Printing is Not Clear	9-7
Paper Incorrectly Fed	9-7
Noise	9-8
Error and Warning Messages	9-8
Warning Messages	9-8
Error Messages	9-9
10 Clearing Paper Jams	10-1
At the Paper Trays	10-2
At the Fuser Unit	10-4
At the Toner Cartridge	10-6
At the Duplex Module	10-8

Duplex at the paper exit	10-8
Duplex at the interior of the top cover	10-9
At the Offset Catch Tray.....	10-10
11 Windows Utilities.....	11-1
Font and Macro Manager Utility	11-1
Status Monitor Utility.....	11-2
PCL5 Tray Mapping Utility	11-2
Direct PDF Utility	11-4

Chapter 1: Introduction

Thank you for selecting the DX-B350P/B450P Laser printer. The DX-B350P prints 35 ppm on Letter paper and 34 ppm on A4 paper. The DX-B450P prints 45 ppm on Letter paper and 43 ppm on A4 paper. This guide contains all of the information necessary to operate and care for your printer and accessories. It is intended to be used after the printer is installed. See the Installation Manual supplied in the box for installation instructions.

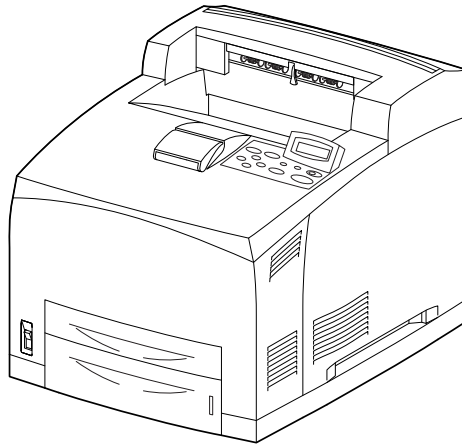

In this Chapter...

- Conventions
- Safety Notes
- Printer Orientation

Conventions

The following conventions are used throughout this guide to emphasize certain procedures or information.

NOTE: A note is a tip or extra information that may be helpful in installing or using the printer.



CAUTION: A caution message provides information that may help you avoid equipment damage, process failure, or inconvenience. Read all caution messages carefully.



WARNING! A warning message indicates the possibility of personal injury if a specific procedure is not performed exactly as described in the guide. Pay close attention to these sections and read them fully to prevent possible injury.

Safety Notes

Introduction

Safety Notes

For your own safety, please read these carefully before using the machine.

- Do not place the machine in a hot, humid, dusty, or poorly ventilated environment. Prolonged exposure to these adverse conditions can cause fire or electric shock.
- Do not place the machine near heaters or volatile, flammable, or combustible materials, such as curtains, that may catch fire.

Printer Orientation

Throughout this guide, the four sides of the printer are referred to as front, rear, right, and left.

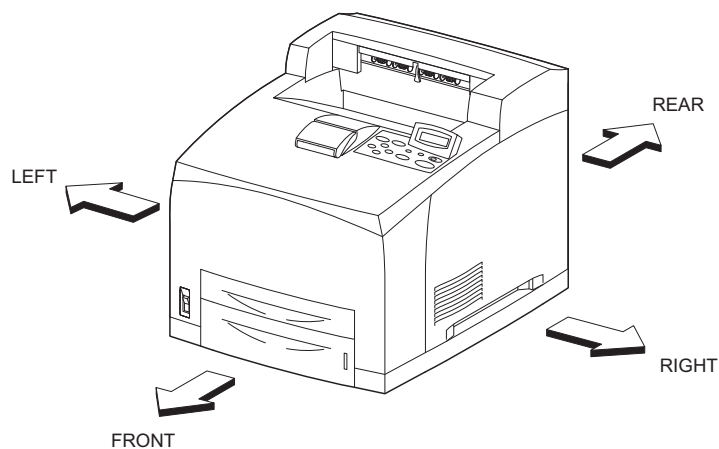

Chapter 2: Getting to Know Your Printer

Components

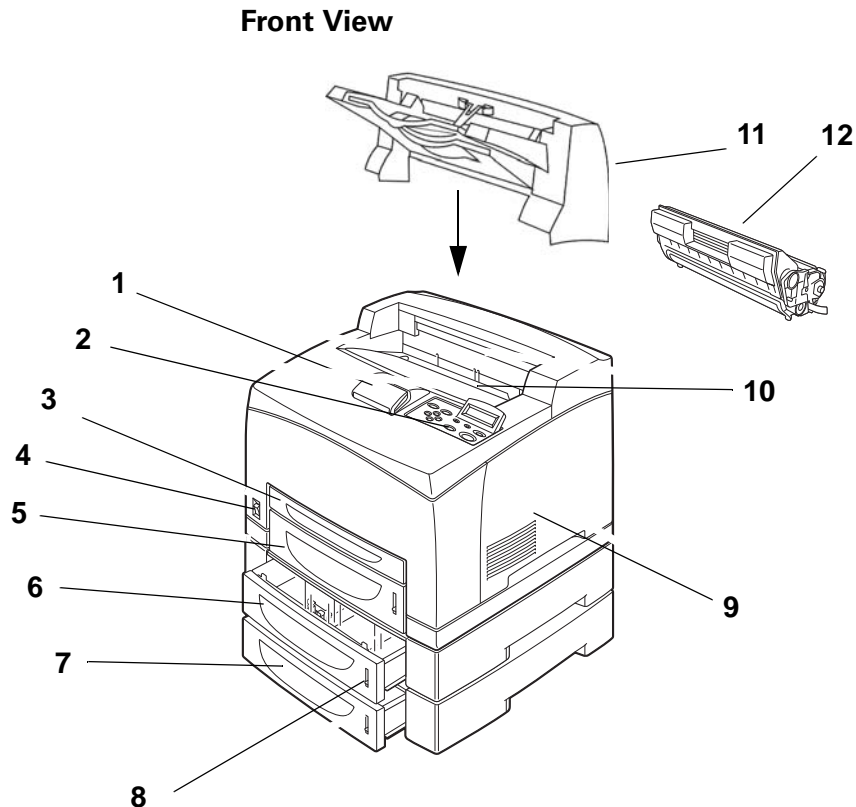

In this Chapter...

- Components
- Turning the Printer On and Off
- Available Printer Drivers
- Paper Usage
- Loading Paper
- Replacing the Toner Cartridge
- Power Save Mode
- Understanding Printing Options

No.	Name
1	Paper Stop
2	Operator Panel
3	Tray 1 - Capacity is 150 sheets 20 lb. (75 gsm) paper
4	Power Switch
5	Tray 2 - Capacity is 550 sheets 20 lb. (75 gsm) paper
6	Tray 3 (Optional Tray Module) - Capacity is 550 sheets 20 lb. (75 gsm) paper
7	Tray 4 (Optional Tray Module) - Capacity is 550 sheets 20 lb. (75 gsm) paper
8	Paper Gauge
9	Access panel for installation of Memory, Hard Disk (HDD), and Compact Flash.
10	Standard Output Tray - Capacity is 500 sheets 20 lb. (75 gsm) paper
11	Offset Catch Tray (Optional) - Capacity is 500 sheets 20 lb. (75 gsm) paper
12	Toner Cartridge

Components

Getting to Know Your Printer

The maximum paper capacity with all options installed is 1800 sheets of 20 lb. (75 gsm) paper.

The label in each paper tray indicates the maximum stacking capacity for certain paper types.

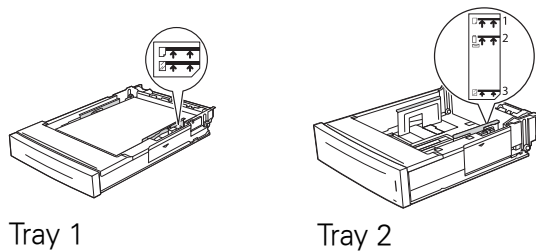

Rear View

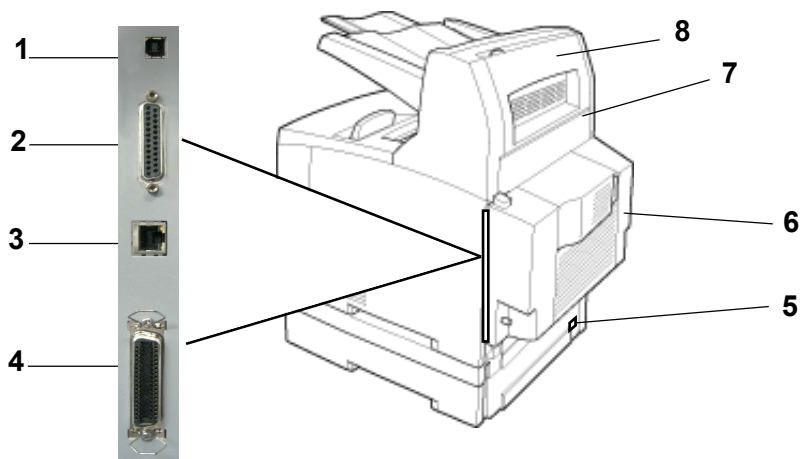

No.	Name
1	USB 2
2	Serial RS-232
3	Ethernet 10/100 Base-Tx
4	IEEE 1284 Parallel
5	Power Receptacle
6	Optional Duplex Module
7	Rear Cover, access to Fuser
8	Offset Catch Tray Rear Cover

Data I/O connector settings can be configured via the Operator Panel's Interface Menu. There are settings for each of the I/O ports including IEEE-1284, USB2, Serial RS-232, and Ethernet.

Internal Components

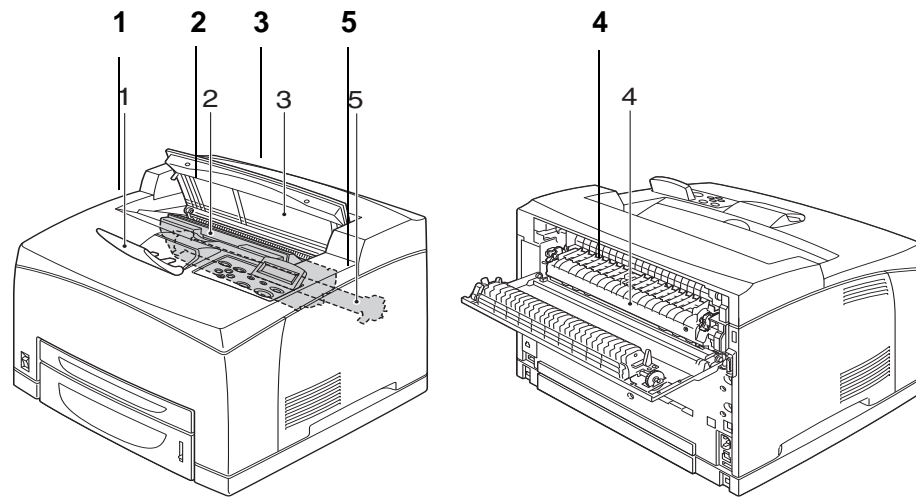

No.	Name	Description
1	Paper Stop	Raise this when printing on paper larger than A4/Letter size.
2	Toner Cartridge	Contains the toner and the photosensitive drum.
3	Top Cover	Open this when replacing the Toner Cartridge and removing jammed paper.
4	Fuser Unit	Fixes the toner on the paper. Do not touch this when using the printer as it is hot.
5	Transfer Roll Cartridge	Transfers the toner image on the surface of the photosensitive drum to the paper.

Turning the Printer On and Off

Getting to Know Your Printer

Turning the Printer On and Off

Turning the Printer On

1. Press the power switch to the <I> position to turn the power on.

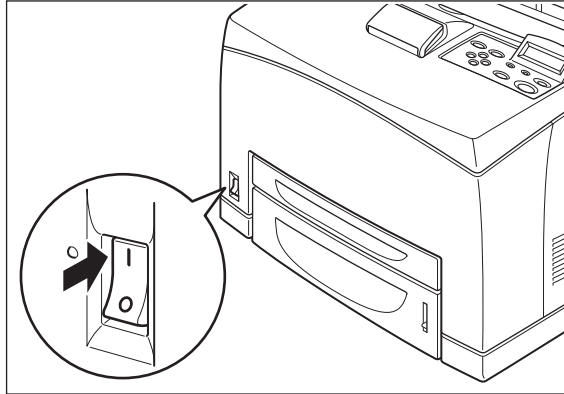

Turning the Printer Off

1. Make sure that the printer is not processing a print job.
2. Press the power switch to the <O> position to turn the power off.

Remember to turn off the printer at the end of the day or when the printer will not be used for an extended period of time.

NOTE: When the printer is turned off, all print data still in memory will be erased.

Available Printer Drivers

Drivers are available for the following Microsoft Windows operating systems: Vista 32/64, XP 32/64, Server 2003 32/64, Server 2008 32/64, NT 4, and 98. Drivers for the following Page Description Languages (PDLs) are available for each of the above operating systems:

- PostScript 3
- PCL5e
- PCL6

The printer contains PCL5c, PCL6, and Adobe® PostScript® 3™ printer languages.

PPDs are provided for Mac OS X (10.2 - 10.5) on the installation CD.

Paper Usage

This section describes available paper sizes, paper types, recommended papers, unusable paper, and which paper types and sizes can be used in which trays.

NOTE: GSM indicates the weight of a 1 m² sheet of paper in grams per square meter.



Using paper that is not suitable for this printer might lead to paper jams or poor print quality. To make full use of the printer features, use only paper that is recommended in the recommended paper table.

Paper Sizes

The printer supports the following standard paper sizes. All standard sizes listed can be printed from all four input trays and output to the Standard Output Tray or the optional Offset Catch Tray.

Paper Sizes
Letter (8.5 x 11in)*
Legal (8.5 x 14in)*
Legal13 (8.5 x 13in)*
Executive (7.25 x 10.5in)*
Invoice (5.5 x 8.5in)
COM9 (3.875 x 8.875in)
COM10 (4.125 x 9.5in)
Monarch (3.875 x 7.5in)
A4 (210 x 297mm)*
A5 (148 x 210mm)*
A6 (105 x 148mm)
B5 (182 x 257mm)*
C5 (162 x 229mm)
DL (110 x 220mm)
Custom

*These sizes are automatically sensed by the printer. If you want to use a size that is not auto sensed, you must select the size on the Operator Panel. See section “Paper Menu” on page 3-6.

Custom Sizes

In addition to the standard sizes of paper you can use, you can also print on custom size paper from any tray. The custom size paper must meet the following guidelines.

- All Custom sizes must be fed short edge first.
- Paper smaller than 3 in by 5 in (76.2 mm by 127.0 mm) or larger than 8.5 in by 14 in (215.9 mm by 355.6 mm) cannot be printed.
- Paper smaller than 3.5 in by 5.5 in (88.9 mm by 139.7 mm) must be printed from Tray 1 and cannot be duplexed or output to the Offset Catch Tray.

Insert paper in the tray so the side to be printed is facing up and the short edge of the paper goes into the printer first. On the Operator Panel, use the Paper>Media Size/Type Menu to set Auto-Sense OFF and then set Custom Size for the intended tray. Then use your application software printer driver to send data to be printed on the installed custom size paper. See section “Custom Size Paper” on page 4-14. When using the EWS, turn Auto-Sense OFF and press Submit to gain access to Custom Size settings.

Paper Types

The printer supports the following paper types

Paper Types	Fuser Mode	Restrictions
Plain (64-105 gsm DX-B350P) (68-105 gsm DX-B450P)	Normal	None
Transparency	Transparency	No duplex Half speed on DX-B450P
Pre-Punched	Normal	None
Letter Head	Normal	None
Color	Normal	None
Pre-Printed	Normal	None
Bond	Thick1	None
Labels	Thick1	No duplex
Cardstock	Thick2	No duplex
Postcard	Thick1	None
Envelope	Thick1 for DX-B350P Thick3 for DX-B450P	No duplex Half speed on DX-B450P
Thick 1 (106-159 gsm)	Thick1	None
Thick 2 (160-216 gsm)	Thick2	None

Paper Types	Fuser Mode	Restrictions
Thick 3 DX-B450P only	Thick3	No duplex Half Speed on DX-B450P Not available on DX-B350P
Thin (64-67 gsm) DX-B450P only	Thin	Not available on DX-B350P

You should set your printer Media Type to Thick1 or any of the other paper types that use Thick1 fuser mode for any paper that is from 106 gsm to 159 gsm. If your paper is 160 gsm to 216 gsm, you should set your printer Media Type to Thick2 or Cardstock. If you do not get satisfactory results using Thick1 or Thick2 on some paper types with rough or uneven surfaces, it is possible you will get improved results using Thick3 on the DX-B450P because of the lower fuser temperature and slower paper speed in the printer.

The fuser temperature progression is

DX-B350P:  Eliminate line space

(Low) Transparency → Normal → Thick1 → Thick2 (High) and

DX-B450P:  Eliminate line space

(Low) Transparency → Thin → Thick3 → Normal → Thick1 → Thick2 (Low)

Printing Transparencies

Transparencies can be printed from all trays, but they can not be printed on two sides using the Duplex Module. Only use transparencies designed for laser printers so they can withstand the heat required for fusing. It is possible to damage your printer by using unsupported transparencies.

Loading transparencies into the trays:

1. Remove the tray from the printer.
2. Remove all paper from a tray before loading transparencies.
3. Fan the stack of new transparencies before putting them in the tray.
4. Insert the transparencies into the tray.

Place the transparencies in the input tray with the side to be printed facing up. Do not fully load a tray with transparencies. The printer supports loading 100 transparencies or less in a tray. Handle them by the edges with both hands and avoid getting fingerprints and creases on them.

5. Adjust the paper guides to fit the transparencies.
6. Insert the tray firmly into the printer.
7. Using the Operator Panel or EWS, select the Transparency Media Type and correct Media Size for the tray to be used.

Getting to Know Your Printer

8. In the printer driver or the computer application program, select Transparency as the paper type you wish to use.

Printing Envelopes

Envelopes can be printed from all trays. There are 5 sizes of standard envelopes that can be used. They are COM10, COM9, C5, Monarch, and DL. All other envelope sizes must be specified as custom size. Only use envelopes designed for use in laser printers. The heat from the fuser can melt some adhesives and possibly damage your printer.



Caution: Never use padded envelopes or those with windows or metal clasps. These can damage your printer.

Loading envelopes into the trays:

1. Remove the tray from the printer.
2. Insert the envelopes into the tray.
3. Adjust the paper guides to fit the envelopes.

All sizes of envelopes go in all trays with the printing side up, “**flap-side down**”, and the top of the envelopes toward the **right** side of the printer.

Do not load more than 15 envelopes in Tray 1 or more than 80 in Trays 2 – 4.

4. Insert the tray firmly into the printer.
5. Using the Operator Panel or EWS, select the Envelope Media Type and correct Media Size for the tray to be used.
6. In the printer driver or the computer application program, select Envelope as the paper type you wish to use, and select the size and orientation of the image to be printed.

Printing Labels

Labels can be printed from any tray. Use labels that were designed for use in laser printers. See section “Available Paper” on page 2-9 for recommendations.

Insert the labels into the tray and adjust the guides to fit the sheets. Place the side to be printed facing up and the top of the sheets to be fed into the printer first. Do not load more than 100 label sheets in Tray 1 or more than 290 in Tray 2 – 4, and do not fill any tray above the fill line marked inside the tray.

Use the Operator Panel Paper>Media Size/Type Menu to select the Label Media Type and size for the tray in use. Then use your computer’s application software to print the labels. See section “Printing on Special Paper” on page 4-13 for further detail about using your computer to print labels.

Available Paper

The following table describes common brands of paper and other media that are supported for this printer.

Paper Type	Paper Name	Weight (gsm)	Size	Part Number
Plain, Pre-Punched, Letter, Color, Pre-Printed				
	Xerox 4200DP 20lb	75	Letter	3R2047
	Xerox RX80 Premier	80	A4	3R91720
	Hammermill Photo White	105	Letter	10246-7
	Hammermill Fore MP	90	Legal	10127-9
	Multicopy Nymolla	100	A4	AMA157091
	Xerox Premier80	80	A5	3R91832
	FX Green100	70	A4	V883
	Berga Focus	80	A4	67393
	Hammermill Tidal MP	75	Letter	16200-8
	Boise Cascade	75	Letter	P10X9001
	Steinbeis Recycled	80	A4	3R91165
	Wiggins Teape Conqueror	90	A4	CON90F
	Xerox RX90	90	A4	3R91854
Envelope				
	COM10 Envelope, Action	75	COM10	43687
	DL Envelope, Autofil	80	DL	JB04122
	C5 Envelope, Autofil	80	C5	JB1933
	COM 9 Columbia	75	COM9	WEVCO115
Labels				
	30up Paper Label	Label	Letter	5160
	Xerox 24up Paper Label	Label	A4	3R96178
	Xerox 24 cut Label	Label	A4	3R97408
Transparency				
	Clear Transparency	Transparency	A4	V516
	3M Transparency(CG3300)	Transparency	Letter	CG3300 LT
	Xerox Permanent Stripe Transparency	Transparency	Letter	3R2780
	Xerox Paper Backed Transparency	Transparency	Letter	3R3028
	Xerox Clear Transparency	Transparency	A4	3R96002

Paper Usage

Getting to Know Your Printer

Paper Type	Paper Name	Weight (gsm)	Size	Part Number
	3M Transparency(CG3300) A4	Transparency	A4	CG3300 A4
Postcard				
	Xerox Postcard Premier TCF160 CUT	160	A6	3R91798A
Thick 1, Thick 2, and Thick 3				
	Xerox Premier200gsm	200	A4	3R93011
	Oxford Index Card	200	3 by 5	40801
	Xerox 65lb Cover Stock	176	Letter	3R3041
	Springhill 110lb Index	203	Letter	15445
	Xerox Premier160gsm(Premier TCF160)	160	A4	3R91798
	Classic Crest Super Smooth	216	Letter	NEE04631
	Shiraoi	156	A4	DK245
	Xerox Color Expressions	120	Letter	3R11540
	Xerox 4200 DP Bond	75	A4	3R2594
	Xerox 4200 DP Bond	75	letter	3R2047
Cardstock.				
	Xerox Premier200gsm	200	A4	3R93011
	Oxford Index Card	200	3 by 5	40801
	Xerox 65lb Cover Stock	176	Letter	3R3041
	Springhill 110lb Index	203	Letter	15445
Bond				
	Xerox Color Expressions	120	Letter	3R11540
	Xerox 4200 DP Bond	75	A4	3R2594
	Xerox 4200 DP Bond	75	letter	3R2047
Thin (DX-B450P)				
	EP_R	64	B5	V632

Unusable Paper

Using the following types of paper might cause paper jams, malfunctions or damage to the printer. Do not use these types of paper.

- Full-color transparencies
- Paper that is too thick or thin
- Paper that has been printed on before (including color printing)
- Wrinkled, folded, or torn paper
- Wet paper
- Curled paper
- Paper with static electricity
- Adhesive paper
- Postcards with pictures
- Paper with special coatings that may be melted by hot fusing temperatures
- Treated colored paper
- Paper using ink that will run at a temperature of 150 °C
- Heat sensitive paper
- Carbon paper
- Paper with staples, paper clips, ribbons, or tape
- Paper with rough surfaces such as pulp paper or fibrous paper
- If acid paper is used, the characters might appear fuzzy. Replace it with alkaline paper.
- Envelopes with windows or metal fasteners
- Labels which do not fully cover the adhesive backing
- Transparencies which are not designed for laser printers (i.e., inkjet transparencies)
- Paper that cannot be heated.

Loading Paper

1. Place the paper tray on a flat surface.

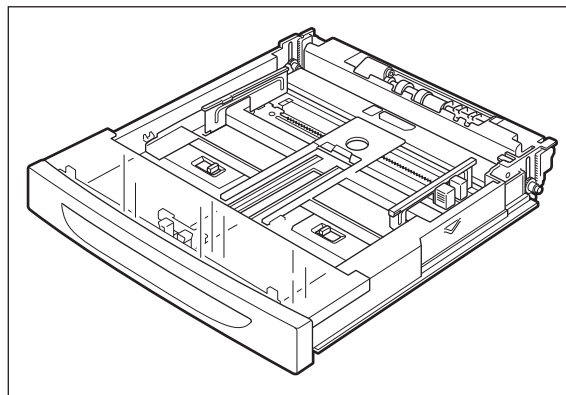

Loading Paper

Getting to Know Your Printer

2. Remove the lid.

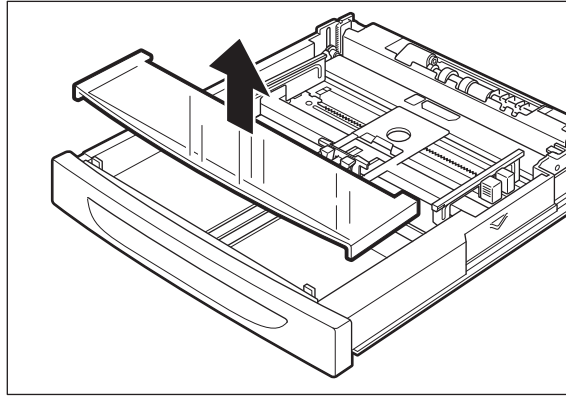

3. If the base plate of the paper tray is raised, push it down.

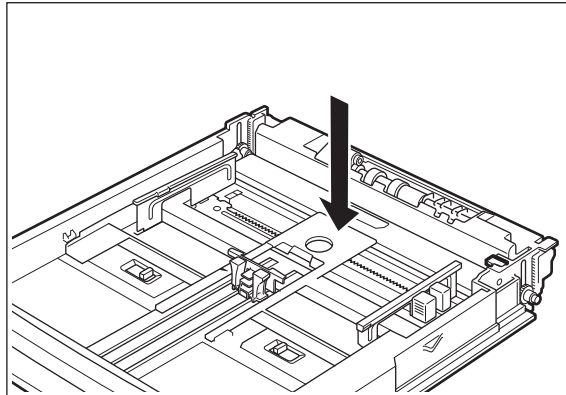

4. Squeeze the length guide and slide it to the desired paper size.

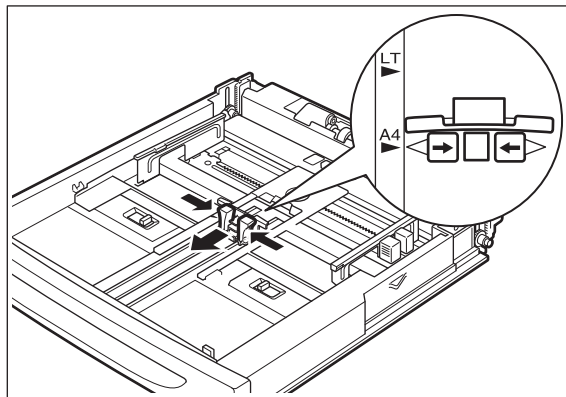

5. Squeeze the right width guide and slide it to the desired paper size.

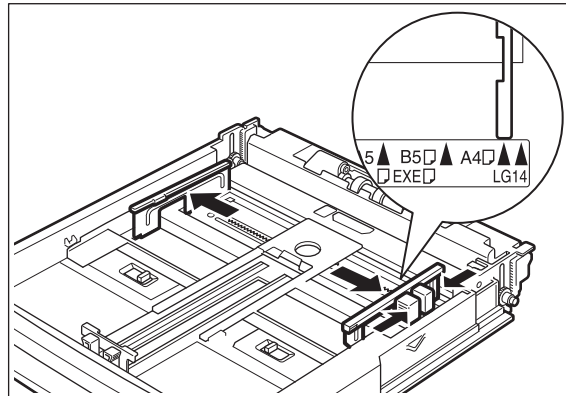

6. Fan the paper well.

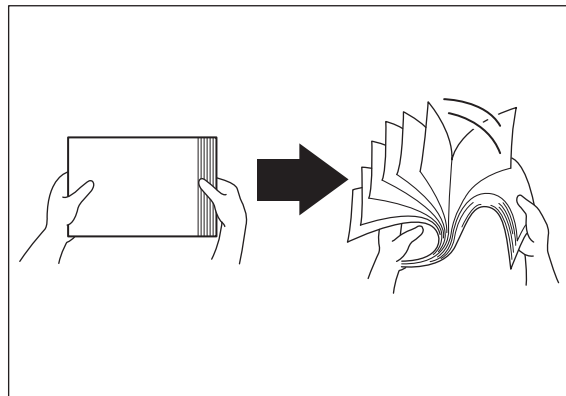

7. Load the paper with the side to be printed facing up and all 4 corners aligned. Make sure the right width guide is correctly aligned with the paper.

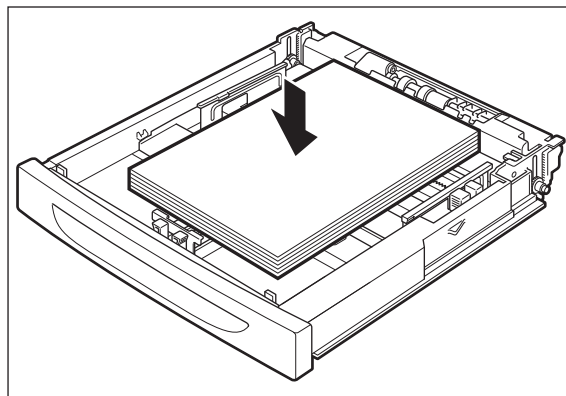

NOTE: Do not load paper exceeding the maximum fill line or the maximum capacity allowed. Align the right width guide to the paper width. If the right width guide is not in place, the paper will not be properly fed and may cause a paper jam.

Loading Paper

Getting to Know Your Printer

8. Replace the lid of the paper tray and firmly close the lid.

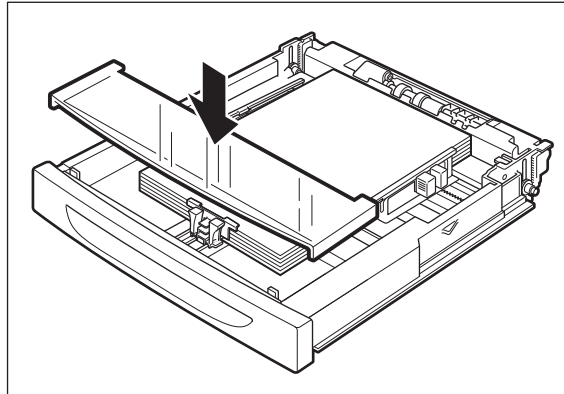

9. Firmly insert the tray in the printer.

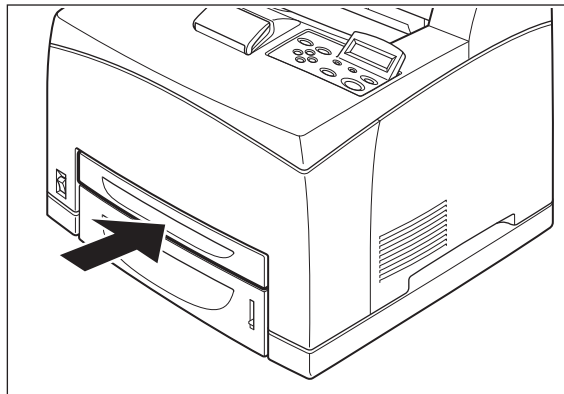

Loading Paper Larger Than A4/Letter Size In The Paper Tray

1. Place the paper tray on a flat surface.
2. Remove the lid of the tray.
3. Slide the right and left lock tabs in the paper tray outwards to unlock them.

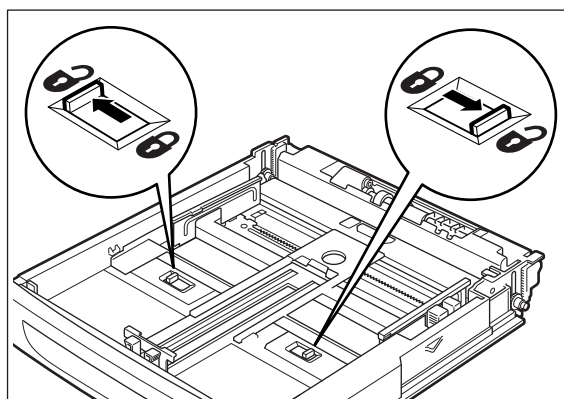

4. Grasp the front of the paper tray and extend it until the right and left lock tabs in the paper tray move inwards and lock automatically.

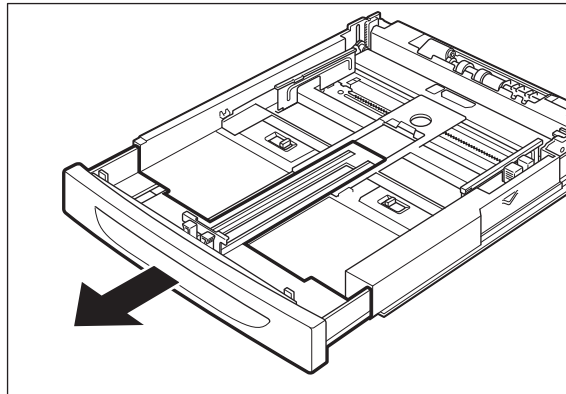

5. Squeeze the length guide and slide it to the desired paper size.

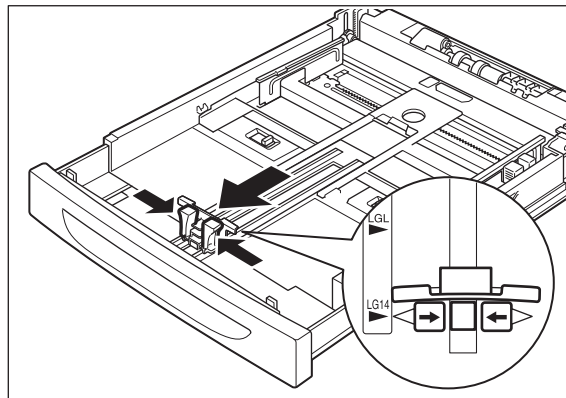

6. Squeeze the right width guide and slide it to the desired paper size.
7. Load the paper with the side to be printed facing up and with all 4 corners aligned.
8. Close the lid of the paper tray.
9. Push the paper tray firmly into the printer.

Replacing the Toner Cartridge

The Toner Cartridge should be replaced when it reaches the end of its print life. The Toner Cartridge prints up to 18K (DX-B350P)/ 21K (DX-B450P) images. The printer will produce a warning on the Operator Panel to inform you when the remaining toner amount is low. You can press START/STOP to continue printing with low toner.

When installing the Toner Cartridge, take note of the following:

- Do not subject it to direct sunlight or strong light.
- Do not touch the surface of the photosensitive drum.
- Do not stand or place the Toner Cartridge upside down. The drum might get damaged.

Replacing the Toner Cartridge

Getting to Know Your Printer

1. Open the top cover and remove the empty Toner Cartridge.

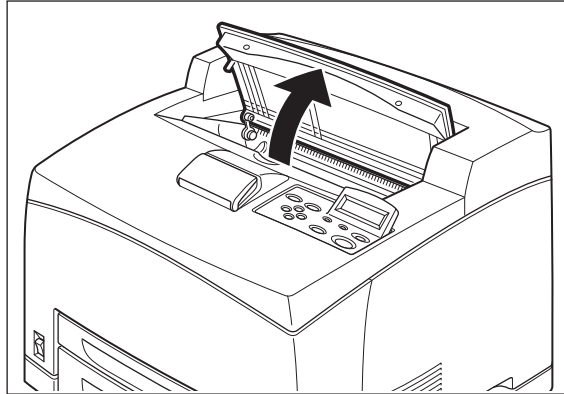

2. Take the Toner Cartridge out of the box and shake it 7 to 8 times as shown in the diagram.

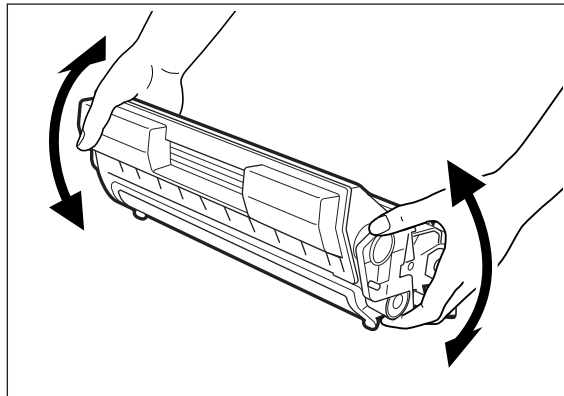

3. Place the Toner Cartridge on a flat surface and pull the seal out horizontally. Note that the seal may offer resistance and a firm pull may be necessary to extract it from the Toner Cartridge.

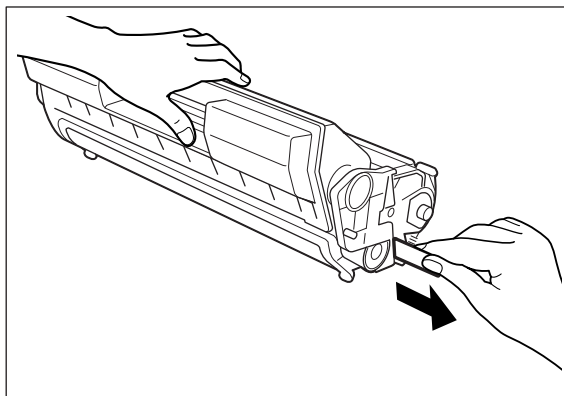

NOTE: When pulling out the seal, pull it out horizontally. The tape might break if it is pulled out diagonally. After the seal has been pulled out, do not shake or bump the Toner Cartridge.

4. Hold the Toner Cartridge by the grip and insert it into the slot inside the printer.

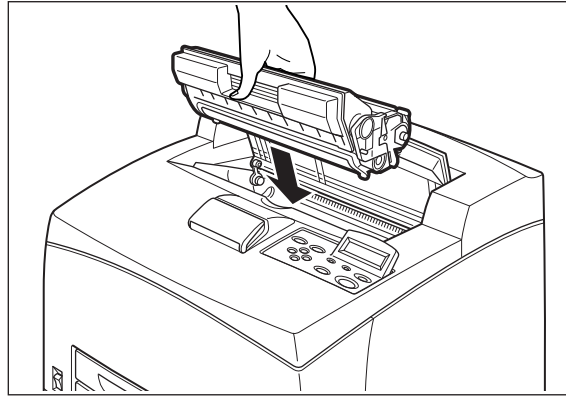

5. Close the top cover securely.

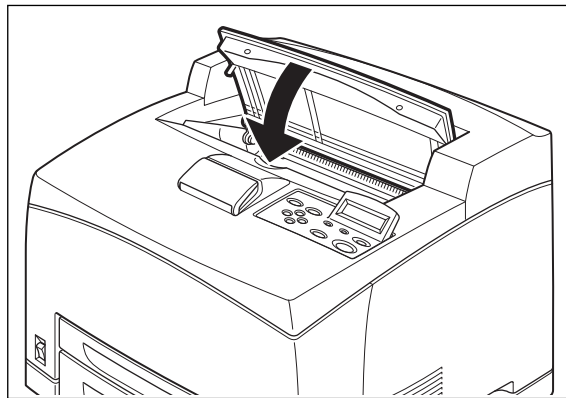

6. Wait for the printer to become Ready.

Power Save Mode

This printer is equipped with a low power mode to reduce power consumption when it is left idle. When no print data is received for 15 minutes (default), the printer will enter Power Save mode. The Operator Panel display indicates the printer is in Power Save mode. Use of the Operator Panel keys will not exit Power Save mode. The printer automatically exits Power Save mode once it receives data. You can change the Power Save time setting using the Operator Panel or the EWS [↓](#)

Understanding Printing Options

The printer offers three ways to modify printing options. The Operator Panel provides an interface at the printer. The Embedded Web Server (EWS) provides remote access via a network. The printer driver provides access to printing options from your computer. Printing options set through an application on your computer supersede settings entered on the Operator Panel or the EWS.

Chapter 3: Operator Panel

Operator Panel Features

The Operator Panel is located on the front of the printer. It contains the display, indicators, and push buttons that allow you to view and change default printer settings. All features of the printer are accessible through the Operator Panel. These changes affect all documents printed unless instructions are provided through your application's printer settings.

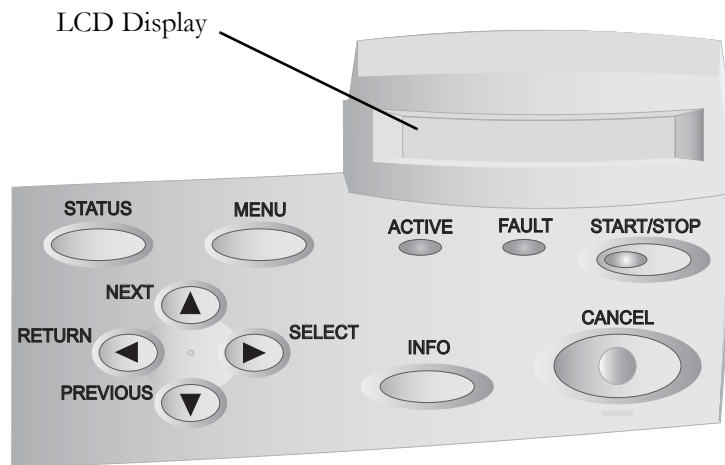

NOTE: If there is a conflict between settings in the Operator Panel, Printing Preferences, or Embedded Web Server and printer settings set via your application, the application settings supersede any other settings.

LCD Display

The LCD display shows status and error messages that inform you of the current status of the printer, and also displays menus, submenus, and printer settings when you are in the menu system. The display contains two lines of text, each with a maximum of sixteen characters.

In this Chapter...



- Operator Panel Features
- Printing a Configuration Summary
- Panel Lock
- Operator Panel Menus

Operator Panel Features

Operator Panel









LED Indicators

The LED indicators indicate printer status. The table below explains the LED indicators.

LED	Color	When Off	When On	When Blinking
START/STOP 	Green	Printer is NOT READY	Printer is READY	N/A
ACTIVE 	Green	Printer is IDLE	Printer is ACTIVE (processing a job)	Printer is WAITING (a partial job has been printed, and the printer is waiting for additional job data)
FAULT 	Red	Printer is not in error mode	There is an error that requires user intervention, such as a paper jam.	N/A

Push buttons

The Operator Panel push buttons allow you to access and navigate menus and also assist you in recovering from printer errors. The table below explains the functions of the nine push buttons.

Button	Function
START/STOP 	Start or stop the printer or exit the menu system. The LED on the Start/Stop button is solid green when ready to print.
MENU 	Enter the menu system.
NEXT 	Move to the next menu, submenu, or setting within the same level of the menu structure.
SELECT 	Select the menu or submenu that is shown on the second line of the display or choose and save the setting shown on the second line of the display.
CANCEL 	Cancel a print job.
STATUS 	Enter the Status Menu and view the current status of various items on the printer.
PREVIOUS 	Return to the previous menu, submenu, or option within the same level of the menu structure.
RETURN 	Move up one level in the menu structure to return to the menu shown on the first line of the display.
INFO 	Print a Configuration Summary.

Navigating the Operator Panel Menu

When you press the **MENU** button on the Operator Panel, you enter the printer's menu system. At that point, the first line of the display contains the text "**Menu**", indicating that you are in the menu system. The second line of the display lists the active menu, which you can change by pressing the **NEXT** or **PREVIOUS** buttons.

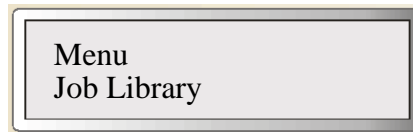

If you press the **NEXT** button repeatedly, the second line of the display cycles through the main menus.

NOTE: Additional menus and submenus may appear in the printer menu system when options are installed.

Sample Navigation

The following figure shows the sequence of push buttons and display messages that would allow you to change the number of copies printed. This example illustrates the basic relationship between menus and submenus and demonstrates how the **NEXT**, **PREVIOUS**, **SELECT**, and **RETURN** buttons help you to navigate through the menus.

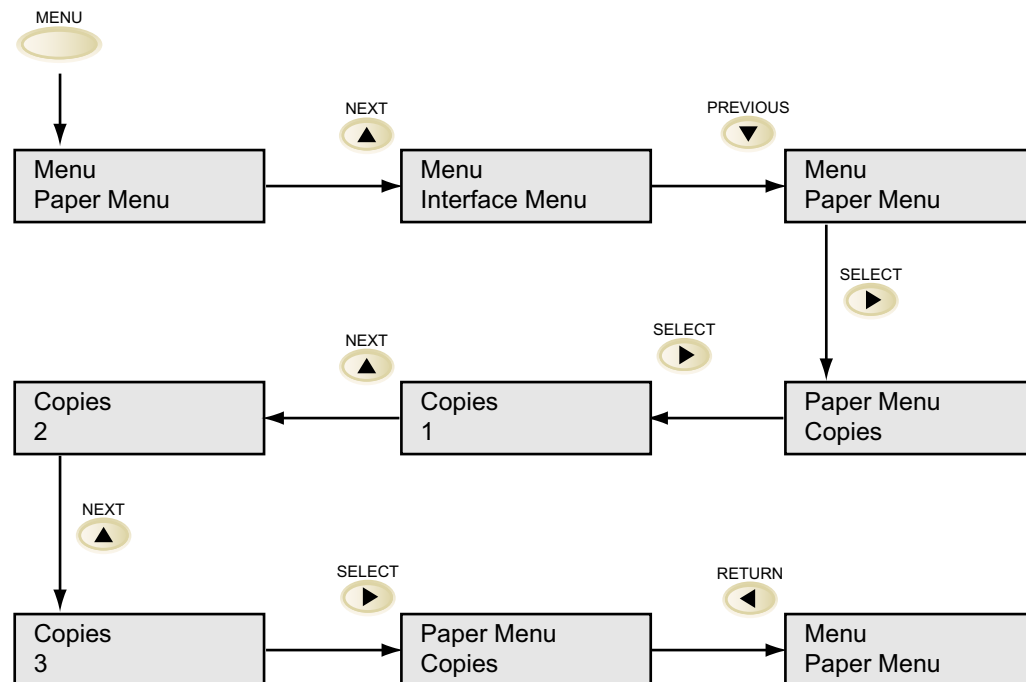

Printing a Configuration Summary

Operator Panel

1. Pressing the **MENU** button on the Operator Panel enters the printer's menu.
The first line of the display contains the text "**Menu**".
2. Press the **NEXT** button until the text "**Paper Menu**" is shown on the second line of the display.
3. Press the **SELECT** button to enter the Paper menu.
4. Press the **NEXT** button until the text "**Copies**" is shown on the second line of the display.
5. Press the **SELECT** button to enter the copies submenu.
6. Press the **NEXT** or **PREVIOUS** button to increase or decrease the number of copies printed.
7. Press the **SELECT** button to save this setting.
8. Press the button to go back to the Main Paper menu or Press the **START/STOP** button to exit the menu system.

Printing a Configuration Summary

Your printer can print a configuration summary that lists the currently selected status of menu options, paper selections in trays, options installed and other relevant information about your printer. To print a Configuration Summary, press the **INFO** button. A multi-page summary prints.

Panel Lock

The Operator Panel can be disabled or enabled at several levels. A series of key combinations control the panel lock. Press and hold the key combination as power to the printer is turned on. Continue to hold the keys down until a confirmation prompt is displayed that confirms that the requested panel function is available. The following key combinations and panel functionality are available.

Panel	Keys Combinations	Allowed Panel Operations
Disabled	START/STOP + CANCEL	Press Start when Continue is displayed on Operator Panel No other panel operations are available other than the key combinations described in this table.
Enabled Level 1	START/STOP + STATUS	User is not allowed to enter Menu mode. User is not allowed to make a Cancel request The remainder of panel functionality is available.
Enabled Level 2	START/STOP + PREVIOUS	Menus can be used to traverse to view menu settings. Menu items summaries can printed. No Menu mode changes are allowed. The remainder of panel functionality is available.
Enabled	Start/stop + RETURN	Panel is completely functional.

Operator Panel Menus

The tables below describe the items available in the Operator Panel. Each item is listed along with the values available for selection. If no values are available for selection, the Value and Default columns are blank. These menu items command the printer to execute an action that takes place immediately.

Job Library Menu

The Job Library menu handles the Job Retention feature's stored jobs that have been sent to the printer from the driver. See section "Job Retention and Storage" on page 4-20 for creating stored jobs in the Windows Driver. Items available in this menu are described below.

Menu Item	Value	Default	Description
Print	Directory name/job name		Print the job stored in the job library. Allows you to access existing directories and to select the desired file. Requires a password.
Print & Delete	Directory name/job name		Print the job stored in the job library and then delete it. Allows you to access existing directories and to select the desired file. Requires a password.
Delete	Directory name/job name		Delete the job stored in the job library and then delete it. Allows you to access existing directories and to select the desired file. Requires a password.

Job Accounting Menu

The Job Accounting menu allows you to print the Job Accounting file or reset job accounting info. Job Accounting from the Windows Driver is described in section "Job Accounting" on page 4-19. Items available in this menu are described below.

Menu Item	Value	Default	Description
Enabled	Yes/No	Yes	
Print Info			Prints the Job Accounting File.
Reset Info			Resets Job Accounting Information.

Operator Panel Menus

Operator Panel

Paper Menu

The Paper menu provides a variety of options for paper type selection as well as paper input and output. Items available in this menu are described below

Menu Item	Value	Default	Description
Copies	1-999	1	Sets number of copies printed.
Duplex	On/Off	Off	Enables two-sided printing
Duplex Bind	2-sided Tablet 2-sided Book	2-sided Book	Choose the binding edge during duplex printing
Default Source	Tray 1-4	Tray 1	Choose a default paper source from a list of all installed trays.
Manual Feed	On/Off	Off	When enabled, the printer prompts you to insert a sheet of paper into Tray 1.
Output Tray	Standard Output Offset Catch	Standard Output	Select the paper output tray.
Media Size/Type			Set the paper type and paper size.
Tray #	Tray 1 Tray 2 Tray 3 Tray 4		Selects the tray to configure.
Media Size	Custom Legal Legal13 A4 Letter B5 Invoice A5 A6 COM9 C5 DL COM10 Monarch Executive	A4 for Europe Letter for US	Sets the media size for the selected tray. Setting is only available if Auto-Sense is Off.

Menu Item	Value	Default	Description
Media Type	Plain Transparency Pre-Punched Letter Head Color Pre-Printed Bond Labels Card Stock Postcard Envelope Thick 1 Thick 2 Thick 3 (DX-B450P only) Thin (DX-B450P only)	Plain	Set the paper type for a selected tray. See “Paper Types” on page 2-6 for more information.
Custom Size	Width Length	110 V: 8.50 x 11.00 in 230V: 210 x 297 mm	Set custom size for the selected tray. See “Custom Sizes” on page 2-6 for more information.
Auto-Sense	On/Off	On	Automatically detects the size of the paper in the tray.
Tray Linking	On/Off	Off	Turn the tray linking function on or off. See “Auto Tray Change” on page 4-15.
Job Offset	On/Off	On	OCT must be installed. Turns Job offsetting on or off. See “Job Offset” on page 4-13. This menu is only shown when the Offset Catch Tray is installed.
Blank Pages	Print Do Not Print	Print	Choose to either print or not print blank pages of a document.
Output Linking	On/Off	Off	Links output trays, so when one is full, it will link to the other. Available when the Offset Catch Tray is installed.
Auto Resize	On/Off	Off	Scale the output of a PS job to the size selected. It does not scale a PCL job. The printer can automatically select the paper that is the closest in size to the paper requested by the printer job. The printer will then scale the job to fit the available paper. This includes scaling A4 to letter and letter to A4.
Separator Page	Off Tray 1 Tray 2 Tray 3 Tray 4	Off	Prints a blank page between print jobs.

Operator Panel Menus

Operator Panel

Menu Item	Value	Default	Description
Custom Size Unit	Inches Millimeters	Inches for 110V mm for 230V	Set the unit of measurement for the Custom Paper Size feature.
Edge to Edge	On/Off	Off	Enables a printing to the physical edge of the paper on all four sides.

Interface Menu

The Interface menu provides a variety of options for port setup and network configuration. Items available in this menu are described below

Menu Item	Value	Default	Description
Port			Enable or disable operations from any I/O interface.
Parallel	On/Off	On	
Serial	On/Off	On	
Network Card 1	On/Off	On	
USB	On/Off	On	
Parallel Setup			Configure the operation of the parallel interface.
Interpreter	Auto Switch PCL PostScript 3	Auto Switch	
Format	Raw Normal Binary	Raw	Configures how incoming print jobs are scanned for special binary control codes. RAW=no processing Normal = "Adobe Standard Protocol" (ASP) Binary = "Binary Control Protocol" (BCP) When Interpreter setting is Auto Switch and this setting is Raw, the printer will automatically determine the control code method, defaulting to Normal if no codes are found.
Mode	Bidirectional Standard	Bidirectional	When set to "Standard", the parallel port operates as a standard parallel port with no bidirectional capabilities. When set to "Bi-directional", the parallel port operates in IEEE-1284 mode, supporting "nibble mode" and "ECP" bidirectional communications modes.

Menu Item	Value	Default	Description
Delay Out Close	On/Off	Off	When ON, the printer will wait until the job is completely printed and delivered to the output tray before terminating the connection, allowing all reverse-channel data to be sent back to the host. This will cause a reduction in printer throughput. When OFF, reverse-channel data generated after the job interpretation is discarded. No reduction in printer throughput occurs.
Binary PS	On/Off	On	When On, the feature allows all binary codes to be processed by the PostScript interpreter. When Off, special binary control codes may be intercepted per the Format item setting.
Serial Setup			Submenu
Interpreter	Auto Switch PCL PostScript 3	Auto Switch	
Format	Raw Normal Binary	Raw	Configures how incoming print jobs are scanned for special binary control codes. RAW=no processing Normal = "Adobe Standard Protocol" (ASP) Binary = "Binary Control Protocol" (BCP) When Interpreter setting is Auto Switch and this setting is Raw, the printer will automatically determine the control code method, defaulting to Normal if no codes are found.
Serial Mode	RS232 RS422	RS232	Serial mode
Baud Rate	1200, 2400, 4800, 9600, 19200, 38400, 57600, 115200	9600	Serial baud rate
Data Bits	8, 7	8	Serial data bits
Stop Bits	1, 2	1	Serial stop bits
Parity	None Even Odd	None	Serial parity
DTR Ready/Busy	On/Off	Off	If On, the DTR signal will reflect the Ready/Busy status.
DTR On1/Off1	On/Off	Off	If On, the DTR signal will reflect the Online/Offline status.
DTR Error	On/Off	Off	If On, the DTR signal will reflect the Error status.
RTS Ready/Busy	On/Off	Off	If On, the RTS signal will reflect the Ready/Busy status.

Operator Panel Menus

Operator Panel

Menu Item	Value	Default	Description
RTS On1/Off1	On/Off	Off	If On, the RTS signal will reflect the Online/Offline status.
RTS Error	On/Off	Off	If On, the RTS signal will reflect the Error status.
XON Ready/Busy	On/Off	On	If On, the XON response will reflect the Ready/Busy status.
XON On1/Off1	On/Off	On	If On, the XON response will reflect the Online/Offline status.
XON Error	On/Off	Off	If On, the XON response will reflect the Error status.
DTR Polarity	High Low	High	Polarity for DTR
RTS Polarity	High Low	High	Polarity for RTS
Robust XON	On/Off	Off	Send Multiple XON codes.
Delay Out Close	On/Off	Off	When ON, the printer will wait until the job is completely printed and delivered to the output tray before terminating the connection, allowing all reverse-channel data to be sent back to the host. This will cause a reduction in printer throughput. When OFF, reverse-channel data generated after the job interpretation is discarded. No reduction in printer throughput occurs.
Binary PS	On/Off	On	When On, the feature allows all binary codes to be processed by the PostScript interpreter. When Off, special binary control codes may be intercepted per the Format item setting.
ETX/ACK	On/Off	Off	
Network 1 Setup			This submenu allows you to set up the Network interface.
Interpreter	Auto Switch PCL PostScript 3	Auto Switch	
Format	Raw Normal Binary	Raw	Configures how incoming print jobs are scanned for special binary control codes. RAW=no processing Normal = "Adobe Standard Protocol" (ASP) Binary = "Binary Control Protocol" (BCP) When Interpreter setting is Auto Switch and this setting is Raw, the printer will automatically determine the control code method, defaulting to Normal if no codes are found.

Menu Item	Value	Default	Description
Network Address	<hex display of MAC address>	NA	Displays MAC address of network interface.
IP Address	data entry	000.000.000.000	IP Address. If DHCP is enabled, this is read-only. Otherwise, this can be changed by the address can be set manually here
Subnet Mask	data entry	000.000.000.000	
Default Gateway	data entry	000.000.000.000	
LPD Banner	On/Off	Off	If ON, prints a special “banner page” before each LPR print job.
DHCP	On/Off	On	
IPv6	On/Off	Off	
Delay Out Close	On/Off	Off	When ON, the printer will wait until the job is completely printed and delivered to the output tray before terminating the connection, allowing all reverse-channel data to be sent back to the host. This will cause a reduction in printer throughput. When OFF, reverse-channel data generated after the job interpretation is discarded. No reduction in printer throughput occurs.
mDNS	On/Off	On	Enabled multicast-DNS protocol. mDNS is the underlying protocol for “Bonjour”.
Local Link	read-only	000.000.000.000	Auto-negotiated “local link” internet address (used primarily by Bonjour protocol)
Multi-Session	On/Off	Off	When On, allows the printer to have multiple network print sessions open at a time. When Off, only 1 session can be opened at a time. Some server environments may benefit from a setting of Off.
EtherTalk	On/Off	On	
Netware Setup			This submenu allows you to set up the Netware interface.
Netware	On/Off	Off	
Netware Frame	Auto-Sense, 802.3, Ethernet II, 802.2 SNAP, 802.2	Auto-Sense	
Netware Mode	NPRINTER PSERVER	PSERVER	

Operator Panel Menus

Operator Panel

Menu Item	Value	Default	Description
Binary PS	On/Off	On	When On, the feature allows all binary codes to be processed by the PostScript interpreter. When Off, special binary control codes may be intercepted per the Format item setting.
Factory Defaults	Yes No	No	Resets the menu to factory network defaults.
Connection Speed	Auto-Sense 100Mbit Half 100Mbit Full 10Mbit Half 10Mbit Full	Auto-Sense	Configures the Ethernet connection speed (10 or 100 Mbits/second) and communication mode (full or half duplex). The "Auto Sense" setting attempts to auto-negotiate this connection with the networking hardware, usually a switch. When a setting other than "Auto Sense" must be used, the following should be considered: If connected to network switch, the "100Mbit/Full" setting can be used. If connected to a hub, use the "100Mbit/Half" setting.
Bidirectional	On/Off	On	When this setting is "on", the printer may receive and send information over the network interface. When this setting is "off", the printer will only receive information over the network interface. This applies primarily when using printing over a "Port 9100" connection. This setting normally should be left at its default setting, should only be turned "off" under special circumstances.
Wait timeout	0000-9999	0270	(In Seconds): Specifies the amount of time the printer will allow a network connection to remain open without transferring data before the printer terminates the connection.
SNMP On/Off	On/Off	On	
HTTP Port	00000-99999	00080	Specifies the TCP port number to use for HTTP connection to the printers embedded web server.
IP Filtering	Disabled Enabled	Disabled	(available via web server only): Allows an administrator to control access to printing and access to the embedded web server on the basis of IP addresses. This is a security feature.
USB Setup			This item allows you to set up the USB interface.
Interpreter	Auto Switch PCL PostScript 3	Auto Switch	

Menu Item	Value	Default	Description
Format	Raw Normal Binary	Raw	Configures how incoming print jobs are scanned for special binary control codes. RAW=no processing Normal = "Adobe Standard Protocol" (ASP) Binary = "Binary Control Protocol" (BCP) When Interpreter setting is Auto Switch and this setting is Raw, the printer will automatically determine the control code method, defaulting to Normal if no codes are found.
Delay Out Close	On/Off	Off	When ON, the printer will wait until the job is completely printed and delivered to the output tray before terminating the connection, allowing all reverse-channel data to be sent back to the host. This will cause a reduction in printer throughput. When OFF, reverse-channel data generated after the job interpretation is discarded. No reduction in printer throughput occurs.
Binary PS	On/Off	On	When On, the feature allows all binary codes to be processed by the PostScript interpreter. When Off, special binary control codes may be intercepted per the Format item setting.

PS Menu

The PS menu allows you to Print PS Errors. Items available in this menu are described below

Parameter	Value	Default	Description
Print PS Errors	On/Off	Off	Choose to either print or not print PS errors.

PCL Menu

The PCL menu allows to set a variety of PCL settings. Items available in this menu are described below

Parameter	Value	Default	Description
Orientation	Portrait Landscape	Portrait	Choose the orientation of the page.
Font Source	Internal User FLASH Hard Disk Compact Flash	Internal	Choose the source of the default font.
Font Number	0-158	50	Set the default font number.

Operator Panel Menus

Operator Panel

Parameter	Value	Default	Description
Pitch	0.08 - 100.00	10.00	Change the default pitch of text.
Symbol Set	All available symbol sets	10U:PC-8 CP437	Choose a default symbol set.
Lines Per Page	5-128	60/Letter 64/A4	Change the default number of lines per page. Default value varies by paper size selected.
CR Mode	CR=CR CR=CR/LF	CR = CR	Define the default action prompted by a carriage return—a carriage return equals either a carriage return alone, or a carriage return and a line feed together.
LF Mode	LF=LF LF=CR/LF	LF = LF	Define the default action prompted by a line feed—a line feed equals either a line feed alone or a carriage return and a line feed together.
FF Mode	FF=FF FF=CR/FF	FF = FF	Define the default action prompted by a form feed—a form feed equals either a form feed alone or a carriage return and a form feed together.
Print Area	Normal Expanded	Normal	Set the print area.
Parameter Values			submenu
Paper Source	Tray 1 Tray 2 Tray 3 Tray 4 Auto-Select	Varies per tray	Set the escape sequence for paper source.
Paper Size	Executive Letter Legal Invoice Legal13 A6 A5 A4 B5 Monarch Com10 DL C5 Com9	Varies per size	Set the escape sequence for paper size.

System Menu

The System menu allows you to specify system-level operation of the printer during normal and certain error conditions. Items available in this menu are described below

Menu Item	Value	Default	Description
Factory Defaults	U.S. Non-U.S.	U.S. for 110V Non-U.S. for 230V	Resets the menu to factory defaults. You change these defaults by changing the options in the Operator Panel; however, settings in the driver will override Operator Panel settings.
Save Config			Saves current configuration.
Restore Config			Restores configuration.
Toner Low	Stop Continue	Stop	Stop printing or Continue printing when the Toner Low message is first displayed. When the print cartridge is low on toner, the Operator Panel displays this message. The printer normally has about 500 pages left to print before the print density fades. In its default state, the printer will stop printing when it detects the toner is low. You can continue printing by pressing the START/STOP button. The printer will then continue printing indefinitely without operator intervention, even if it runs out of toner. The warning message remains displayed on the Operator Panel. If the printer is set to Continue after Toner Low, the printer will not stop and will continue to print even with no toner available.
Display Language	English Francais Deutsch Italiano Espanol Dutch Danish Norwegian Swedish	English	Change the language of the display messages.
Power Save	3-120	15	Set the time in minutes since last print before entering Power Save mode. See "Power Save Mode" on page 2-17 for more information.
Wait Timeout	00000 - 99999	00020	Increase or decrease the length of time (in seconds) that the printer will remain in the waiting state—a job is being processed, no end-of-file has been detected, and there is no more data to process. This setting applies to both PCL and PostScript print jobs.

Operator Panel Menus

Operator Panel

Menu Item	Value	Default	Description
Job Timeout	00000 - 99999	00000	Increase or decrease the limit (in seconds) for the total time of processing a PostScript job. A 0 setting indicates no timeout. This setting applies only to PostScript jobs.
Jam Recovery	On/Off	On	Turn jam recovery on or off.
Hex Print	On/Off	Off	Print a job in hexadecimal for a technician to use in diagnosis of a datastream problem.

Quality Menu

The Quality Menu allows you set image quality options. Items available in this menu are described below

Parameter	Value	Default	Description
Resolution	600 dpi 1200 dpi	600 dpi	Set the resolution (dpi).
Toner Saver	On/Off	Off	Turns toner saver on or off
Print Density	1-7	4	Specifies how dense the toner is to be applied to the page.

Functions Menu

The Functions menu provides a variety of performance and summary reports. Items available in this menu are described below

Parameter	Value	Default	Description
Print Usage Rep			Prints the usage report.
Reset Printer			Reboots the printer. All data in not in non-volatile memory will be lost
Print Summary			Prints the configuration summary (same as pressing the Info button)
Network Summary			Prints the network summary.
Print Test	Single Continuous		Prints a test page.
Print Fonts	PCL Fonts PostScript Fonts		Prints a font list for PostScript or PCL.
Print Error Log			Prints the error log.

FLASH/Disk/CF Menu

For each installed drive: FLASH, Disk, CF the following menu items are available. The menu only appears on the Operator Panel if the accessory is installed. Items available in this menu are described below

Menu Item	Value	Default	Description
Print	List of files		Prints the selected file.
Delete			Deletes the selected file.
Format <i>device_name</i>	SELECT CANCEL		Formats user flash. All data stored on the device will be erased.
Flash Summary	Print Summary		Prints the summary file.

Date/Time Menu

The Date/Time Menu provides setup for Date and Time options. Items available in this menu are described below

Menu Item	Value	Default	Description
Month	January through December	current	Set the current month.
Day	1-31	current	Set the day of the month.
Year	2000 - 2099	current	Set the current year.
Hour	1-11 am 1-11 pm Midnight Noon	current	Set the current hour.
Minute	0 - 59	current	Set the current minute.
Second	0 - 59	current	Set the time in seconds.
Offset from GMT	-12 through + 12 hours 0 or 30 minutes	0	Select your time zone.

Status Information

Status information is printed on the Configuration Summary.

Category	Description
Status Info	This listing on the Configuration Summary provides the status for each tray's Paper Type, Paper Size, and capacity used. It also provides Toner status (consumable life tracking). Usage Count displays the current amount of usage of the printer.
Information	This listing on the Configuration Summary provides data about the printer such as the product version, PostScript version and images printed.
Options Info	This listing on the Configuration Summary tells you which options are installed on the printer.

Changes to some configuration items may not be available in the Operator Panel. Some items are only configurable via the EWS and do not appear in the Operator Panel although their configuration is displayed in the Configuration Summary.

Parameter	Value	Default	Description
Interface Setup			
Host Name	data entry	Model Name plus last 7 digits of MAC (Network) address	Hostname to use when referring to the printer by name, rather than IP address.
DNS Primary IP	data entry	000.000.000.000	IP address of the Domain Name Server. Needed when enabling email notifications via the EWS when DHCP has been disabled. When DHCP is enabled, this item shows the assigned IP address.
DNS Secondary IP	data entry	000.000.000.000	If the primary DNS does not respond, use this secondary DNS.
DNS Domain Name	data entry	empty	Name of the Domain used by DNS.
WINS Primary IP	data entry	000.000.000.000	
WINS Secondary IP	data entry	000.000.000.000	
WINS Host Name	data entry	Model Name plus last 7 digits of MAC (Network) address	
mDNS Host Name	data entry	Model Name plus last 7 digits of MAC (Network) address	

Parameter	Value	Default	Description
mDNS SVC Name	data entry	Model Name plus last 7 digits of MAC (Network) address	
Current Zone		empty	Shows the name of the current zone for EtherTalk networking
Preferred Zone		*	Allows you to choose from a list of existing zones. * uses the default zone.
Netware Setup			
Print Server Name	data entry	Model Name plus last 7 digits of MAC (Network) address	
NDS Tree Name	data entry	empty	
NDS Context	data entry	empty	
Job Poll Interval	0-255	0	
Print Server SAP Name	data entry	Model Name plus last 7 digits of MAC (Network) address	

Understanding Page Counters

Page Counters are included in Status information.

Counter Type	Definition
Image Counter	This counter reflects the number of images (sides) printed for the printer.
Toner Page Count	This counter reflects the number of pages printed using the installed cartridge.
Sheet Counter	This counter displays the number of sheets (one sheet equals two sides) the printer has printed.
Usage Count	<p>This counter calculates usage by image count regardless of page size. Simplex pages equal one, while duplex pages equal two images.</p> <p>A Usage.csv file is stored in User Flash that includes information about the printer (such as Product Name, Serial Number, and Date) and the Usage Counter values. This file is in comma-separated-value format and can be accessed via the printer's File Management web page.</p> <p>The printer can also be configured, via the EWS, to generate an email that includes Usage Counter information. The email will be sent on the first of each month (or the first time the printer is powered on in any new month). The email contains the Usage.csv file.</p>
Fuser Count	This counter counts images. Pages larger than A4/Letter are counted as two images. Pages that are Letter/A4 or smaller are counted as 1 image in simplex mode and 2 images in duplex mode. Pages larger than Letter/A4 are counted as 2 images in simplex mode and 4 images in duplex mode.

Chapter 4: Windows Operations

This chapter describes features of the Windows Driver. The driver allows you set default settings for all print jobs as well as print settings for individual print jobs. Similar features may be available in the Operator Panel or EWS. If there is a conflict between settings in the Operator Panel, Printing Preferences (default driver settings), or Embedded Web Server and printer settings set via your application for individual print jobs, the application settings supersede any other setting.

Installing PCL5e and PostScript 3 Drivers

The Sharp Installation CD installs the PCL6 printer driver which is the best driver choice for most users. PCL5e and PostScript 3 are also provided on the installation CD and can be installed as follows:

1. Place the Sharp Installation CD into your CD drive.
2. From the Control Panel, select **Printers and Faxes**.
3. Right-click in the printer list and select **Add Printer**.
The Add Printer Wizard appears.

4. Click **Next**.

The Local or Network Printer screen appears.

5. Select **Local printer attached to this computer** and deselect **Automatically detect and install my Plug and Play printer**.

6. Click **Next**.

The Select a Printer Port screen appears.

7. Select **Use the following port** and select the port from the pulldown list.

8. Click **Next**.

The Install Printer Software screen appears.

9. Select **Have Disk...**

An Install From Disk dialog appears.

In this Chapter...

- Installing PCL5e and PostScript 3 Drivers
- Setting Default Values
- Printing a Test Page
- Cancelling Printing
- Accessing the Driver from an Application
- Navigating the Printer Properties Window
- Saved Settings
- Main Tab
- Paper Tab
- Advanced Tab
- Job Handling Tab
- Watermark Tab

Setting Default Values

Windows Operations

10. Click **Browse...** and navigate to:
<CD drive>\Drivers\<Language>\<Platform>\<PDL> where:
 - <CD drive> is the drive letter for your CD drive, typically this is D:
 - <Language> is:
 - ENUS is for English drivers
 - FREN is for French drivers
 - SPAN is for Spanish drivers.
 - <Platform> is:
 - W2K is for Windows 2000, Windows XP, Vista, Server 2003 32bit and Server 2008 32bit.
 - W9X is for Windows 98 and Windows ME.
 - W64 is for Vista 64bit, Server 2003 64bit and Server 2008 64bit.
 - WNT is for Windows NT4.
 - <PDL> is:
 - PCL is for PCL5e drivers
 - PS is for PostScript 3 drivers
 - XL is for PCL6 drivers

For example, the path D:\Drivers\ENUS\W2K\PS installs the English PostScript 3 drivers for XP.
11. Select either SHARP DX-B450P or SHARP DX-B350P driver, depending on your model.
12. The Name Your Printer screen appears.
13. Click **Next**.
14. The Printer Sharing screen appears.
15. Click **Next**.
16. The Print Test Page screen appears.
17. Click **Next**.
The Wizard is complete.
18. Click **Finish**.

Setting Default Values

The Printer Properties window can be accessed through your Windows Printers and Faxes Menu to make changes that apply to all jobs by default. You may only need to access this feature the first time you install the driver.

To set default values from Printers and Faxes:

1. Select the **Printers and Faxes** from your Start menu.
2. Right-click the desired DX-B350P/B450P printer and select **Properties**.

The Printer's configuration window appears.

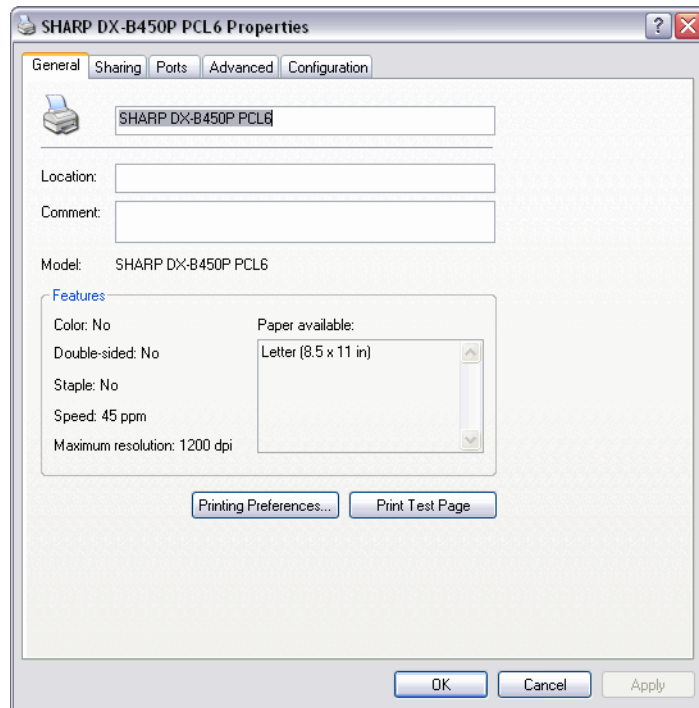

The driver can automatically recognize all the installed options for your printer. To get the installed options, click the Configuration tab and then the Auto Configuration button. You can also manually install an option by selecting it from the pulldown and changing its status.

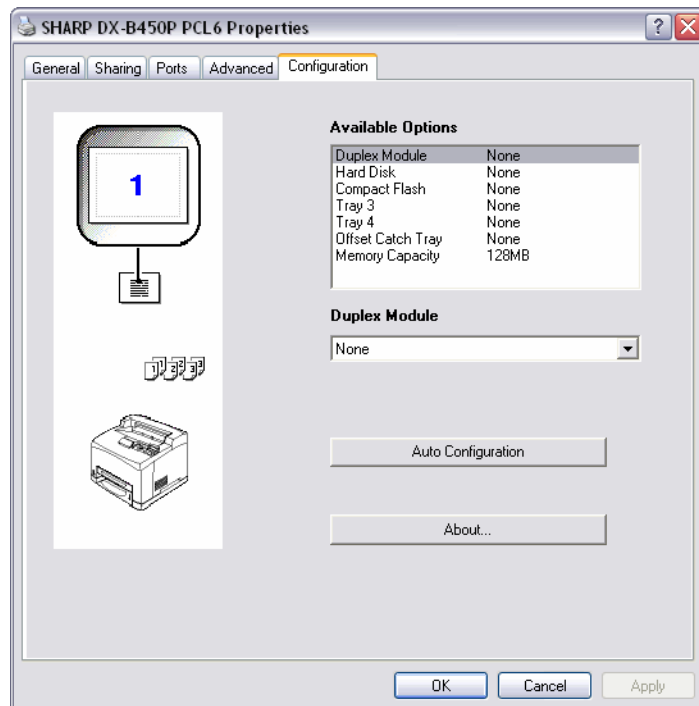

Printing a Test Page

Windows Operations

3. On the General Tab, click **Printing Preferences**

The Printing Preferences window appears.

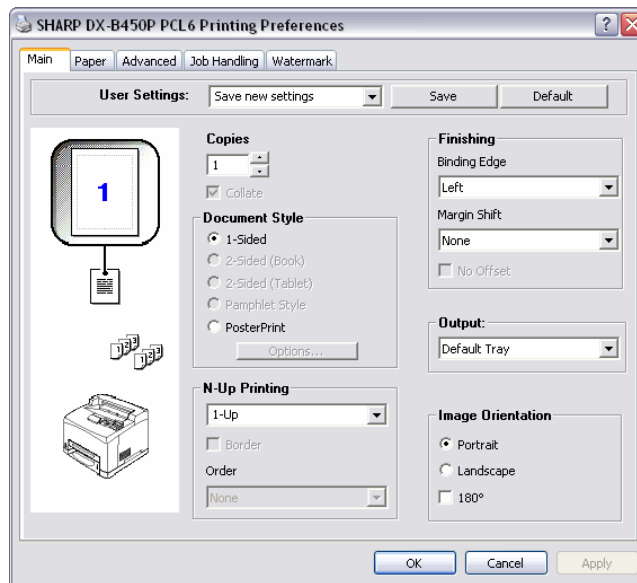

4. Any options set in any tab become your default values.

Printing a Test Page

You can print a Test page to verify printer connectivity and operation.

To print a test page through your Printer Properties:

1. Select the **General** tab within your Printer Properties accessed by right-clicking your printer.
2. Click **Print Test**.
3. Click **OK**.
4. Click **OK**.

Cancelling Printing

To cancel printing, you can either cancel the print job at the printer or at the computer.

Cancelling a Print Job at the Printer

Press the CANCEL button then press the Start button on the Operator Panel. Pages being printed at the moment will continue to be printed.

Cancelling Print Jobs at the Computer

Double-click the printer icon  at the bottom right of the taskbar in Windows.

From the displayed window, click the document name that you wish to delete and press the Delete key.

Accessing the Driver from an Application

Windows Operations

Accessing the Driver from an Application

To make changes that apply to documents printed from a specific application, access Printer Properties from the application.

NOTE: If there is a conflict between settings in the Operator Panel, Printing Preferences, or Embedded Web Server and printer settings set via your application, the application settings supersede any other setting.

To access Printer Properties from an application:

1. Select the **Print** option from your application.
2. Select the desired DX-B350P/B450P printer.
3. Click the Printer's **Properties** button.

The Printer's Properties window appears.

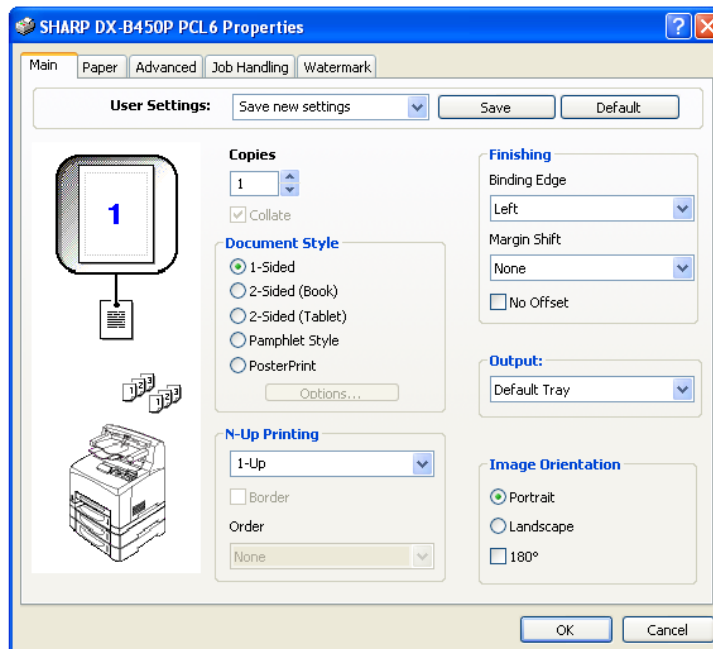

Navigating the Printer Properties Window

The driver screens are divided in to five groups of functionality as described in the table below.

Tab	Functions	Comments
Main	Copies Document Style N-up Printing Finishing Output Image Orientation	Allows you to select number of copies, one or two-sided printing, binding and margin shift, output destination, and page orientation.
Paper	Paper Size Paper Selection Zoom Settings Cover Sheet Selection Options	Allows you to choose paper size and type, image scaling, cover sheets, and other paper and input tray options.
Advanced	Manual Adjustment Overlay Options Font Substitution Quality	Allows you to adjust image quality, print overlays, and control font substitution.
Job Handling	Retention Settings Job Accounting	Allows you to configure Job retention and Job Handling.
Watermark	Watermark	Allows you to configure watermarks.

Saved Settings

As you create groups of settings in your Printer Properties, you can save that group of settings. You can then select that group of settings by the name under which you saved them. This can save you time and effort when printing.

To save a group of settings in your Printer Properties:

1. Set up your print job by choosing all options you wish to reuse in the Printer Properties.
2. Click the **Save** button that is located next to the Saved Settings pulldown in all tabs within your Printer Properties.
3. Enter a Name for the saved settings.
4. Click **OK**.
5. Click **OK**.

To use saved settings:

1. Select the desired *setting_name* from the Saved Settings pulldown in all tabs within your Printer Properties.
2. Click **OK**.

Main Tab

Selecting Number of Copies

You can select the number of copies to print via your Printer Properties. When selecting the number of copies, you should also decide if those copies are collated.

To select number of copies:

1. Select the **Main** tab within your Printer Properties.
2. Either enter the number of copies or click the arrow buttons to increase or decrease the number of copies selected.
3. Click **OK**.

Collating Copies

When printing multiple copies of a job, the output can be automatically collated. When copies are collated, they are printed in groups by the print job, not by the page. If you do not select the collate option, your copies will be printed by page. So, ten page number 1's will print and then ten page number 2's will print. Collated jobs will print all pages in sets, pages 1 through 10, until all sets have been printed. The default for Collating is On when there is more than one copy being printed.

To select collating through your Printer Properties:

1. Select the **Main** tab within your Printer Properties.
2. Click **Collate**.
3. Click **OK**.

Setting Image Orientation

Select portrait or landscape orientation or select to rotate the existing orientation by 180 degrees.

To select orientation through your Printer Properties:

1. Select the **Main** tab within your Printer Properties.
2. Select the desired orientation.
You can choose Portrait, Landscape, or to rotate the page 180 degrees.
3. Click **OK**.

Output Destination

You can choose the output tray where your print job will be placed.

To select the paper destination through your Printer Properties:

1. Select the **Main** tab within your Printer Properties.
2. Select the desired tray from the **Output** pulldown.
3. Click **OK**.

Document Style (2-Sided Printing/Duplex)

The printer can automatically print on both sides of paper when the optional Duplex module is installed. See "Paper Types" on page 2-6 for information about what paper cannot be duplexed.

With two-sided printing, you can print a document in the form of a small book. You can use any paper size that duplex printing supports. The printer automatically reduces pages to fit within the pamphlet parameters. It prints two pages per side and prints the pages in the order needed to accommodate a center fold. You can specify the binding edge (see "Finishing" on page 4-12) to specify the room left for binding your book.

To print on both sides of the paper from your Printer Properties:

1. Select the **Main** tab within your Printer Properties.
2. Select Book, Tablet, or Pamphlet 2-sided printing.

You can select how the printer will orient the page layout when duplexing. Depending on your page orientation, duplexing on the long-edge or short-edge of the paper produces different results.

2-sided Book prints as shown below.

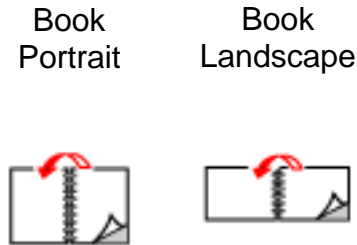

2-sided Tablet prints as shown below.

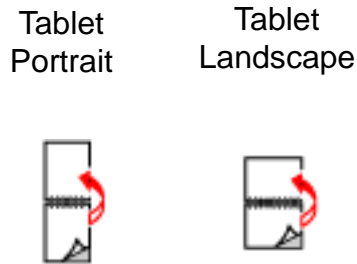

Pamphlet Style prints as shown below.

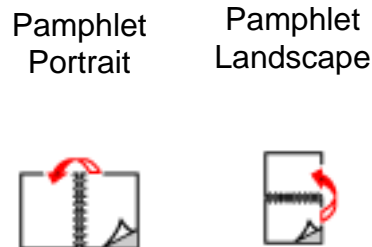

3. Click **OK**.

Poster Printing

If you have a large page image that can not be printed on the available paper sizes, you can print the document in poster print. Poster Print prints the document to a full bleed (to the edges of paper with no border) and breaks the document up into multiple pages. The pages can then be placed together, edge-to-edge, to create a large version of the print job.

To print in poster mode:

- 1.** Select the **Main** tab within your Printer Properties.
- 2.** Select the **PosterPrint** Document Style.
- 3.** Click **Options**.
The PosterPrint window appears.
- 4.** Enter the desired parameters.
Enter the X and y axis enlargement and orientation.
- 5.** Click **OK**.
- 6.** Click **OK**.

Multiple Pages to Single Sheet (N-up)

You can print multiple pages on a single sheet when printing a multi-page document. This can save paper and is handy for draft reviews. You can print one, two, four, six, eight, nine, or sixteen pages per sheet.

To select the number of pages to print on a single page:

1. Select the **Main** tab within your Printer Properties.
2. Select the number of pages to print from the N-Up pulldown menu.
3. Check the Border box if a page border is desired.
4. Select the Order in which the pages should be placed on the page.
5. Click **OK**.

Finishing

You can add room on a page to allow for binding without modifying the document in the authoring application.

To allow room for binding:

1. Select the **Main** tab within your Printer Properties.
2. Click the **Binding Edge** and **Margin shift** distance from the pulldown menus in the Finishing area.

The Binding edge can be set to any of the choices in the pulldown list. The margin shift distance specifies how far to move the page image over to allow for binding.

3. Click **OK**.

Job Offset

The Offset Catch Tray can place sheets in alternate positions to separate one print job from another. This is called job offsetting. When selected, the output position changes after the final sheet of the print job is printed. The next job is offset (shifted a bit) to keep it separate from the previous print job. The Offset Catch Tray must be installed to use this option. Once installed, this feature is enabled by default.

To disable Job Offset through your Printer Properties:

1. Select the **Main** tab within your Printer Properties.
2. Select **No Offset** in the Finishing area
3. Click **OK**.

Paper Tab

Source

You can select the input tray from which paper is used to print the job.

To select the paper source through your Printer Properties:

1. Select the desired tray from the **Paper Source** pulldown in the **Paper** tab within your Printer Properties.
Automatically Select will choose and available tray.
2. Click **OK**.

Printing on Special Paper

The printer can accommodate a variety of special paper such as Transparencies, Envelopes, Labels, Index cards, and Postcards. Each paper type requires some special handling. Prior to inserting the paper into the tray, read the sections in “Paper Types” on page 2-6 for each special paper type.

Settings in the Operator Panel and in your Printer Properties are required to specify the special paper loaded in the specified tray. Paper type settings must match those of the actual paper loaded in the trays. Otherwise, image quality cannot be processed accurately. Toner may not fuse properly on the paper, resulting in dirty and poor quality printouts.

To select the special paper types through your Printer Properties:

1. Change media size at Operator Panel via the loaded tray’s Paper Menu’s Media size selection or using the EWS.
2. Select the **Paper Type** from the pulldown in the **Paper** tab within your Printer Properties.
3. Ensure that the **Paper Source** is set to a paper tray that is loaded with the required paper.
4. Click **OK**.

Selecting Paper Size

You can select from a list of standard paper sizes. Available sizes are defined in “Paper Sizes” on page 2-5.

To select the paper size through your Printer Properties:

1. Select the **Paper** tab.
2. Select the desired paper size from the Paper Size pulldown.
3. Click **OK**.

Custom Size Paper

When loading custom size paper in the tray, adjust the paper guides as necessary. See “Custom Sizes” on page 2-6 for additional information about custom sizes.

To load and print custom paper:

1. Load the paper in the desired tray and set the custom paper size as described in section “Custom Sizes” on page 2-6.
2. Select the **Paper** tab within your Printer Properties.
3. Click **Custom Size**.
The Custom Size window appears.
4. Enter the paper parameters.
5. Name the custom size and add it by clicking the Add button.
6. Click **OK**.
7. Select the saved paper size from the Paper size pulldown.
8. Click **OK**.

Cover Sheet

Cover Sheet Selection

A cover sheet is the first page of the document. The printer enables you to choose a different paper source for the cover sheet than for the rest of the document. You can then use a different stock paper for the first page of the document while sending the document as a single print job. The paper must be the same size as the rest of the document.

To enable cover sheets through your Printer Properties:

1. Select the **Paper** tab within your Printer Properties.
2. Check **Use Cover Sheet**.
3. Select the Paper Source and Paper Types from the pulldowns.
4. Click **OK**.

Zoom Settings

You can scale any page image to fit the paper size being used. Zoom settings are unavailable if you have chosen a Document style of N-Up or Pamphlet. Fit to Page is unavailable if you have chosen Pamphlet.

To scale the print image to fit on a page:

1. Select the **Paper** tab within your Printer Properties.
2. Click the **Fit to Page** radio button.
3. Select the paper size from the pulldown.
4. Click **OK**.

To zoom in or out to change the size of the page image:

1. Select the **Paper** tab within your Printer Properties.
2. Click the **Zoom** radio button.
3. Click **Settings**.
4. Enter the desired value to scale the image.
5. Click **OK**.
6. Click **OK**.

Auto Tray Change

When an input tray runs out of paper, auto tray changing enables the printer to switch to another available tray that contains the same size and paper type.

To select auto tray changing through your Printer Properties:

1. Select the **Paper** tab within your Printer Properties.
2. Select **Auto Tray Change**.
3. Click **OK**.

Media Check

When Media Check is enabled (default):

The printer first checks the requested input tray, or the printer's default tray if one is not specifically requested, to see if it contains paper loaded that matches the media size and media type specified from your computer.

If the input tray does not contain the requested paper the printer searches other input trays to find one that has paper matching the requirements. If none is found, the printer stops and asks you to load the requested paper. The top line of the Operator Panel display will look like one of the following:

“Load Paper”

or

“Load Paper TrayX” “X” is the tray number where the paper should be loaded.

If “Load Paper” is the displayed message, the paper may be loaded into any tray. If the paper size being loaded cannot be auto-sensed, then the Operator Panel must be used to configure the paper size. After the paper is loaded, the printer will automatically resume printing. If you want to simply continue printing on the default input tray without checking the paper size requested, press the START/STOP key to resume printing.

If “Load Paper TrayX” message is displayed, then loading the requested paper into the indicated tray will cause the printer to automatically resume printing. If the paper is loaded into a tray other than the one indicated, then pressing the START/STOP key will allow the printer to resume printing if “Auto Tray Change” is enabled.

When both Auto Resize and Media Check are ON, the paper size requested, via the driver, will not be enforced because Auto Resize overrides the paper size aspect of Media Check. If you want to enforce a specific paper size, then it is necessary to disable Auto Resize via the Operator Panel’s Paper Menu.

To enable media check:

1. Select the **Paper** tab within your Printer Properties.
2. Check **Media Check**.
3. Click **OK**.

When Media Check is disabled:

The printer will print from the default paper tray. The size or type of paper in the tray is not a factor in paper tray selection.

Skip Blank Pages

If pages exist in your document that do not contain text, you may select not to print them.

To skip blank pages:

1. Select the **Paper** tab within your Printer Properties.
2. Check **Skip Blank Pages**.
3. Click **OK**.

Manual Feed

Tray 1 can be used for manual feed. You must also set your Printer Properties for manual feed. Tray 1 normally operates in multiple-purpose mode, where multiple sheets can be loaded and printed continuously. In Manual mode, you are prompted to press the Start button for each sheet.

To select manual feed through your Printer Properties:

1. Select the **Paper** tab within your Printer Properties.
2. Check **Tray 1 is Manual Feed**.
3. Click **OK**.

Advanced Tab

Manual Adjustments

You can make a variety of adjustments to the Brightness and Contrast of your printed pages when using the PCL6 driver. This feature is not available for PostScript or PCL5e.

Brightness and Contrast can be separately adjusted using the slider controls. You can select Text, Graphic, or Photo elements of the output to be effected by these controls. You can also specify that all elements of the output are effected.

Quality

For all Print driver versions, you can adjust quality settings. These include:

- Resolution
Select 600 dpi for normal printing or 1200 dpi for high quality mode
- Toner Save
This prints everything with less print density.
- Text to Black
This converts color text to be printed solid black instead of representing colors with shades of gray.

Overlay Options

Create Overlays

The Overlay window allows you to create, delete, and edit the behavior of overlays. An overlay is a portion of a document that is added to each page of a print job such as a letterhead or a standard form. There are no pre-defined overlays. You must create overlays through an application. Then the overlay you have created may be included on future print jobs. Create New Overlay will create an overlay when the print job is sent.

To create an overlay:

1. Access your printer's properties from your application.
2. Select the **Advanced** tab within your Printer Properties.
3. Click **Overlay Options**.

The Overlay Window appears.

4. Check **Create Overlay** and enter a name for the overlay.
5. Click **OK** to close the Overlay window.
6. Click **OK** to close the printer properties.
7. Click **Print** in the print dialog and the overlay will be created.
8. Click **OK**.

Using Overlays

After overlays have been created you can select the desired overlay from the Overlay Options list. Then you can define when an overlay should be printed, either All Pages, First Page Only, or All But First Page. The Remove button deletes the selected overlay from the list.

To use an overlay after they have been created:

1. Open any document in any application.
2. Select **File>Print** within that application.
3. Select the DX-B350P or DX-B450P printer.
4. Click **Properties**.
5. Select the **Advanced** tab.
6. Click **Overlay Options**.

The Overlay Window appears.

7. Select the desired Overlay.
Overlay options are: All Pages, First Page Only, and All Pages but First Page.
8. Click **OK** to close the Overlay window.
9. Click **Print** in the print dialog and the document will be printed with the overlay added to every page.

Font Substitution

This feature allows you to substitute TrueType fonts with printer fonts. You can also set the TrueType font output type.

To set font substitution:

1. Access your printer's properties from your application.
2. Select the **Advanced** tab within your Printer Properties.

3. Click the **Font Substitution** button.
4. Select the desired TrueType Download Type.
5. Check Font Substitution checkbox.
6. Click **New** to add a new substitution or **Edit** to change an existing substitution.
You can also delete an existing substitution or reset the substitutions to default settings.
7. Click **OK**.

Job Handling Tab

Job Accounting

Job accounting stores information about each print job received by the printer. You can enter a User Name up to 80 characters and a numeric Job Account ID via the driver. Job accounting can be enabled or disabled via the EWS or Operator Panel. In addition, job accounting information can be viewed online in the EWS or retrieved as a CSV file from the EWS or Operator Panel. Job accounting information can also be reset to create a clean data sheet. The CSV file contains the following information.

Line 1 contains the Job accounting Version number and Model Name

1	A	B	C	D	E	F	G	H	I	J	K	L	M	N	Q	R	S	T	U	V	W
	v104	Job Accounting																			
2	Job ID	Job Name	User ID	User Name	Port	Protocol	Pages (sides)	Pages (sheets)	Date/Time	Duration	T1 Sheet	T2 Sheet	T3 Sheet	T4 Sheet	600DPI Pages	1200DPI Pages	Media Size	Media Type	Duplex	Host	Status
3	0	Microsoft \	0	engineer	Network1		1	1	March 11	0:00:09	0	1	0	0	1	0	Letter	Plain	No	WXPENUS	Printed
4	1	Microsoft \	0	engineer	Network1		1	1	March 11	0:00:10	0	1	0	0	1	0	Letter	Plain	No	WXPENUS	Printed
5																					

Job Accounting Fields

The fields that are currently defined for the Job Accounting data are as follows:

Column	Description
Job ID	An automatically generated number
Job Name	Name from the authoring application
User ID (from Job Account ID in the driver)	ID supplied by the user from the driver.
User Name	Name supplied by the user from the driver.
Port	The port from which the job was printed
Protocol	The protocol used.
Pages (sides)	The number of sides printed.
Pages (sheets)	The number of sheets (2 sided) printed.
Date/Time	Date and time job was printed.

Job Handling Tab

Windows Operations

Column	Description
Duration	How long it took the job to print.
T1 - T4 Sheets	Number of sheets printed from each tray.
600 dpi pages	Number of pages printed at this resolution.
1200 DPI pages	Number of pages printed at this resolution.
Media size	Page size printed. See * Additional paper sizes.
Media type	The type of paper printed on.
Duplex	Yes or no.
Host	Name of the host that sent the print job.
Status	The status of the print job such as, printed, paused, or cancelled.
*Additional Media sizes	If a job contains multiple paper sizes, additional columns are added for each size.

Configure this feature using your Printer Properties. It is enabled at the Operator Panel or EWS.

To use job accounting:

1. Select the **Job Handling** tab within your Printer Properties.
2. Enter the User name and Job Account ID.
3. Click **OK**.

The job accounting information is collected on an internal accounting file within the printer. It can then be downloaded as a .csv file by an administrator via the printer EWS and processed off line by the users accounting application.

Job Retention and Storage

You can store print jobs for future use or hold a job at the printer. A held job may be released with a Password/PIN number when a password was selected in the driver. Enable this feature via your Printer Properties and print the actual stored job by accessing it through the Job Library in the printer's Operator Panel.

The Retention function is used to hold a print job as a file on the printer's internal storage device, allowing the job to be printed from the Operator panel when needed. Internal storage devices can be a hard disk, Compact Flash, or User Flash. The password (a 4 digit number) allows a confidential job to be printed without being seen by others.

When printing a saved file with password, the password must be entered in the Operator Panel.

To set retention options:

1. Select the **Job Handling** tab within your Printer Properties.
2. Click the Retention checkbox.
3. Select the desired job handling function.
4. Enter the job name in the Job name box.
5. Enter password information, if desired.
6. Click **OK**.

Hold Only

This setting is used to hold a print job on the printer's hard disk without printing it. Initiate printing as needed using the Operator panel of the machine.

Hold After Print

This setting is used to hold a print job on the printer's hard disk after it is printed.

Sample Print

When this setting is selected and a print job is sent to the printer, only the first set of copies is printed. After checking the contents of the first set of copies, you can initiate printing from the Operator Panel of the printer and the remaining sets are printed. This prevents the occurrence of excessive misprints.

Password/PIN

Input four digits to set the Password/PIN for the printing job.

Watermark Tab

A Watermark is faded text that appears in the background of all pages or only the first page. The text can indicate items that are draft versions, confidential, or other important marking text.

COPY, DRAFT, and CONFIDENTIAL watermarks are provided. You can view these by clicking on their name in the Watermark Pane of the Watermark Window. You can edit their settings or the settings of any configured watermark by clicking the Edit button.

To create a new watermark to be placed on a print job:

1. Select the **Watermark** tab within your Printer Properties.
The Watermark Window appears.
2. Click **Add**.
The New Watermark window appears.
3. Enter the watermark text.
4. Click **OK**.

Windows Operations

The text is shown centered on the page.

5. Use the sliders to change the size, position, and angle of the text. Click the center button if you wish to recenter the text. Click the First page only text box if you only want the text to appear only on the first page of the document.
6. Click **OK**.

Chapter 5: Macintosh Operations

Installing the Driver

The Mac driver is installed by installing the PPD for the desired printer. The PPD is located on the installation CD. PPD installation may vary by Mac operating system.

To install the PPD:

1. Open System Preferences.

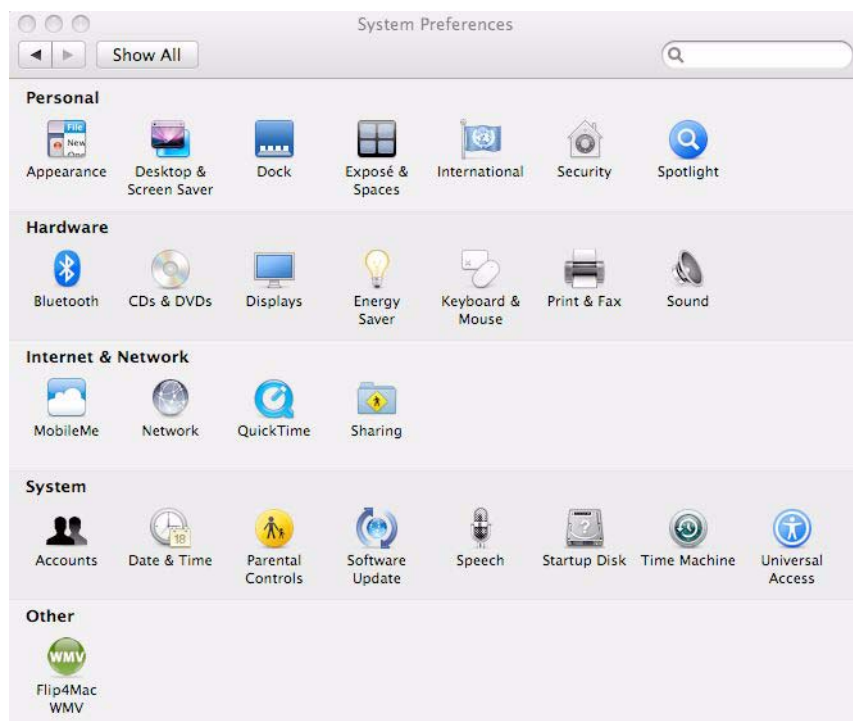

In this Chapter...

- Installing the Driver
- Accessing the Driver
- Navigating the Driver

2. Select **Print & Fax** from the Hardware menu.

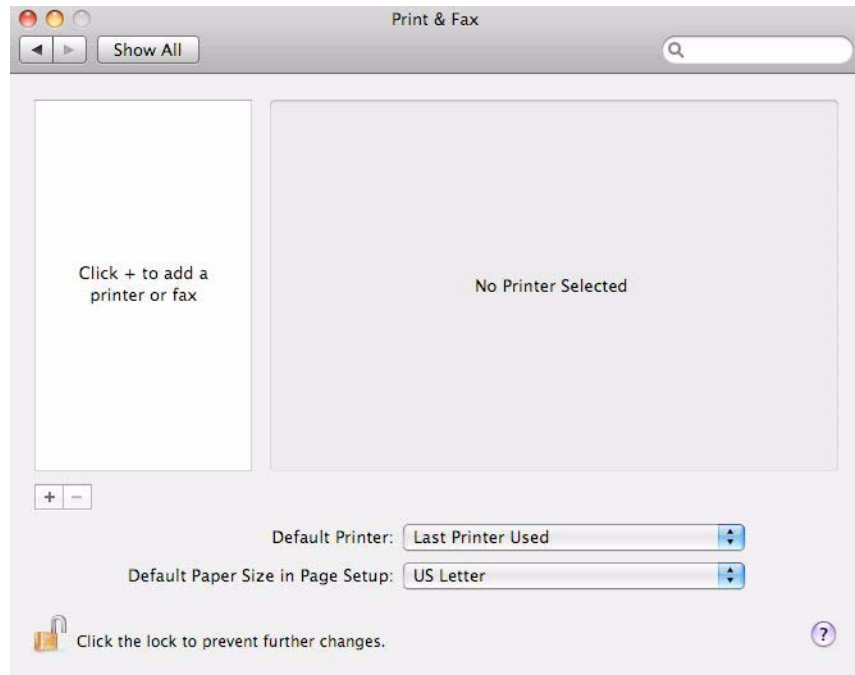

3. Click + to add the printer.

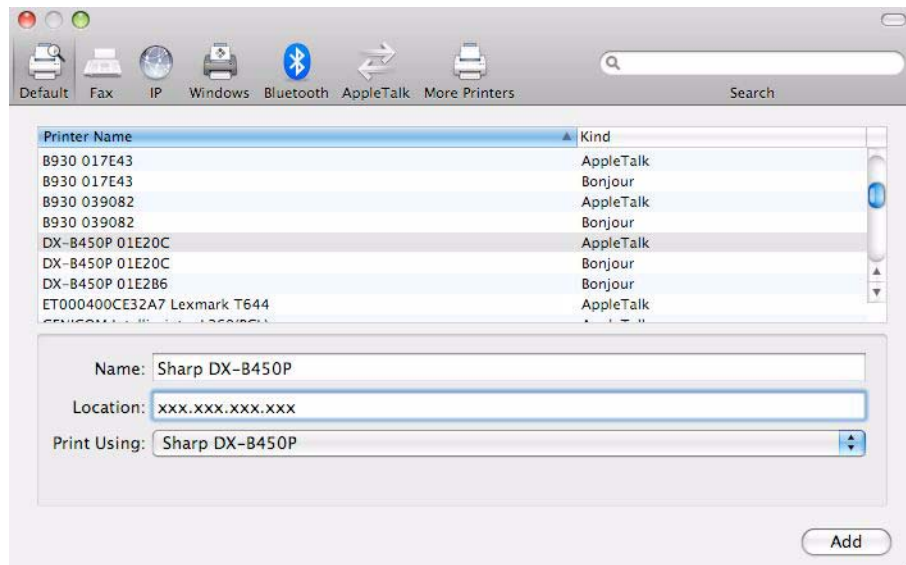

4. Enter a name for the printer.
5. Enter the IP address of the printer in the location field.

6. Select **Other** from the Print Using pulldown.

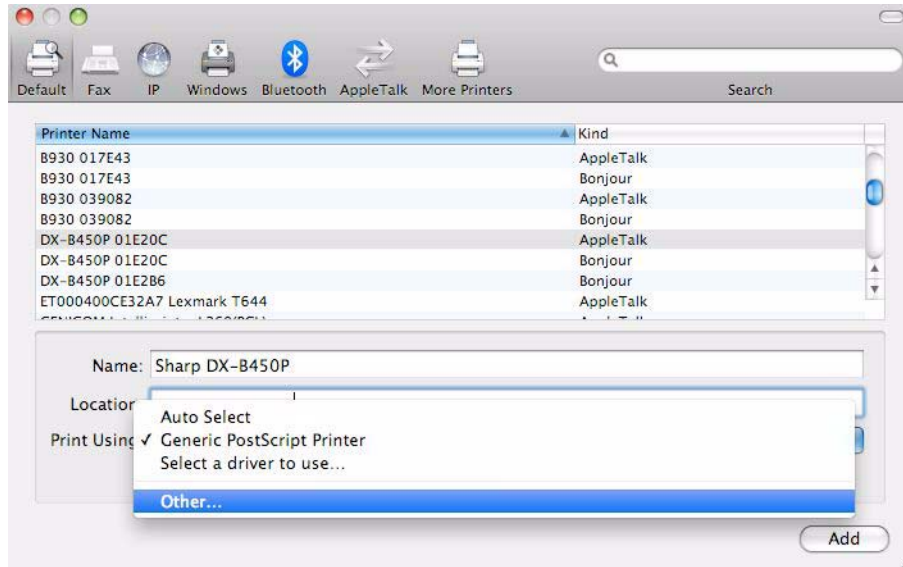

A browse window is displayed.

7. Browse to the CD to select the desired PPD.

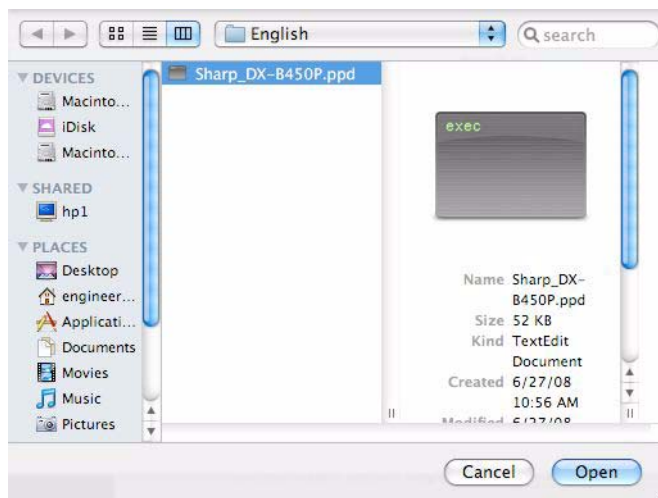

8. Click **Open**.

9. Click **Add**.

The printer is installed.

Accessing the Driver

The Driver can be accessed from your application's Print menu.

NOTE: If there is a conflict between settings in the Operator Panel, Driver, or Embedded Web Server and printer settings set via your application, the application settings supersede any other setting.

Navigating the Driver

Macintosh Operations

Navigating the Driver

Driver features and presentation may vary by Mac operating system. In general, the driver provides a group of “always there” option at the top of the driver window and a pulldown of Printer features available towards the middle of the window.

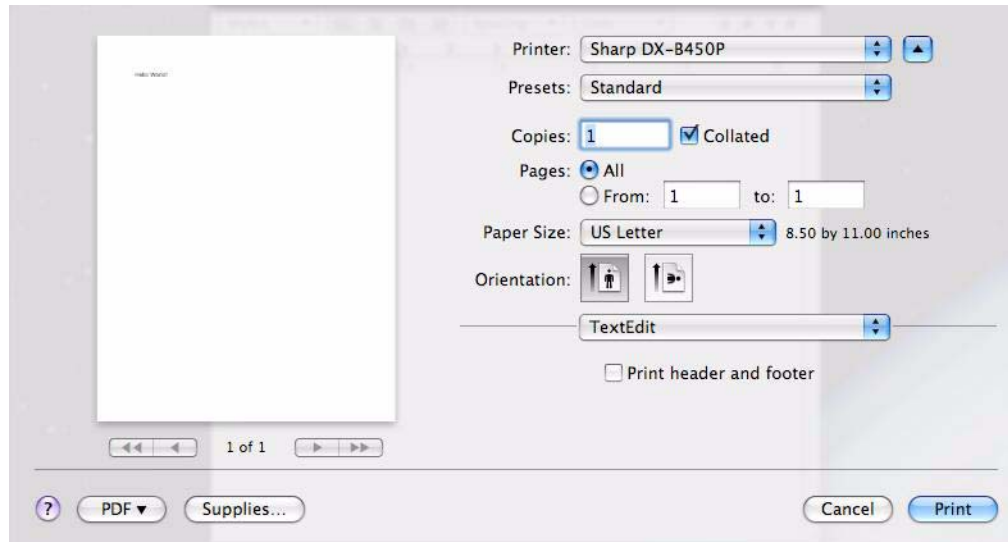

The following table provides a general overview of available features and navigation

Navigation Level 1	Navigation Level 2	Navigation Level 3	Description and Available Items
Always there options:			
Printer			Selects the printer with which to print .
Presets			Selects the presets with which to print.
Copies			Defines number of copies printed.
Collated			Turns the collate option on/off.
Two-sided			Turns the two-sided option on/off .
Paper Size			Determines the paper size to be printed.
Orientation			Selects landscape or portrait.
Pulldown Options			
TextEdit			
	Print header and footer		Prints time, date and document title in the header and page number in the footer.
Layout			
	Pages per Sheet:		Prints multiple pages on a single sheet of paper. Options are: 1,2,4,6,9,16
	Layout Direction		
	Border:		Adds a border around the page image. Options are: Single Hairline, Single Thin Line, Double Hairline, and Double Thin Line.
	Two-Sided:		Long-edge binding, Short-edge binding
	Reverse Page Orientation		Prints the page image upside down.
Color Matching			This printer is monochrome. This Mac feature is settable but not applicable.
	ColorSync, In Printer		NA
	Profile:		Default is "Automatic"
Paper Handling			
	Pages to Print:		Sets the desired pages to print. Options are: All Pages, Odd Only, Even Only
	Destination Paper Size:		Sets the paper type on which to print.
	Scale to fit paper size		Scales the page image to the size of paper being printed.

Navigating the Driver

Macintosh Operations

Navigation Level 1	Navigation Level 2	Navigation Level 3	Description and Available Items
	Scale down only		Prints smaller page sizes on the current page size. Checked by default. .
	Page Order:		Determines the order in which pages are printed. Options are: Automatic* default, Normal, and Reverse.
Paper Feed			Determines from which tray(s) paper is pulled.
	All pages from:		Options are: Auto Select* Default, Tray 1, Tray 2, Tray 3, Tray 4, and Manual Feed
	First page from:		Options are: Auto Select* Default, Tray 1, Tray 2, Tray 3, Tray 4, and Manual Feed. "Tray 1" is default
	Remaining from:		Options are: Auto Select* Default, Tray 1, Tray 2, Tray 3, Tray 4, and Manual Feed. "Tray 1" is default
Cover Page			Provides settings for a cover page that is different than the rest of the print job.
	Print Cover Page:		Options are: None* default, Before document, and After document
	Cover Page Type:		Options are: Standard* default, classified, confidential, secret, topsecret, and unclassified
	Billing Info:		Empty
Scheduler			Provides settings to print the document at a later time.
	Print Document:		Options are: Now* default, At* has place to set time, and On Hold
	Priority:		Options are: Medium* default, Urgent, High, and Low
Printer Features			
	Imaging		
		Resolution	Sets the resolution of the printed image. Options are: 600 DPI* default, and 1200 DPI.
		Toner Saver:	Options are: Printer Setting* default, On, and Off.
		Auto Resize:	Options are: Printer Setting* default, On, and Off.
	General		
		Media Type:	Select the media type.
		Media Check:	Enable or Disable Media Check. See "Media Check" on page 4-15 for more information.
	Output		Sets a variety of output tray options.
		Output Tray:	Default Tray* default, Offset Catch Tray
		Output Jogging:	Options are: Off* default and On. See "Job Offset" on page 4-13 for more information.

Navigation Level 1	Navigation Level 2	Navigation Level 3	Description and Available Items
		Tray Switching	Checked by default
		Jam Recovery	Checked by default

Chapter 6: Embedded Web Server

This printer comes with an Embedded Web Server (EWS). The EWS resides in the printer and requires no installation. The EWS contains access to printer features and presents them as HTML web pages. The changes made via the EWS change the printer settings in the same manner as the Operator Panel. To change settings for specific documents, use your Printer Properties options within the driver.

NOTE: If there is a conflict between settings in the Operator Panel, Printing Preferences, or Embedded Web Server and printer settings set via your application, the application settings supersede any other setting.

In this Chapter...

- Accessing the EWS
- Navigating the EWS

Accessing the EWS

To access the embedded web server, you must be on an IP-based network and have access to a web browser.

In your web browser, type the IP address assigned to the printer. For example `http://192.0.0.1` for IPv4 or `http://[2001:0db8:85a3:08d3:1319:8a2e:0370:7348]` for IPv6.

Navigating the EWS

Embedded Web Server

Navigating the EWS

The EWS interface consists of a left-navigation area and a display area. Use the left-navigation area to locate the desired items and make any configuration changes in the display area.

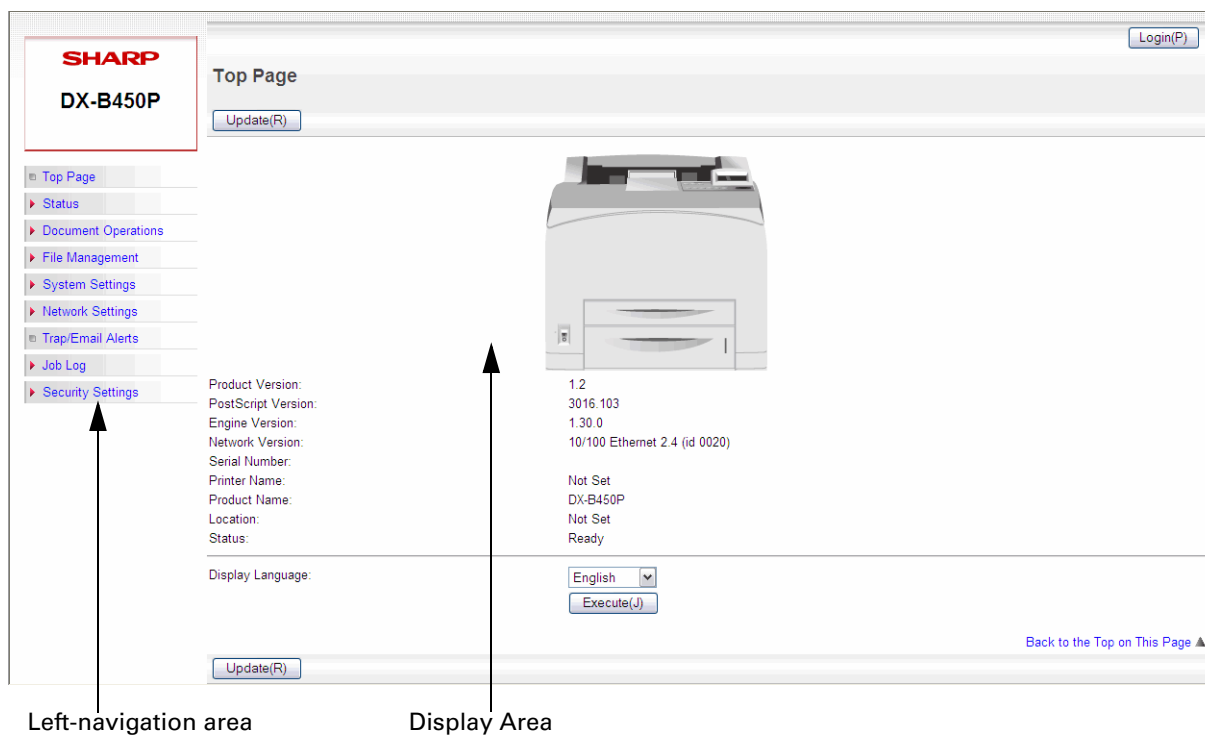

After each selection in the EWS, you must press the Submit button for the request to take effect. The Update button refreshes the screen to show you the current status of the displayed functions.

The following table defines the structure of the EWS. Some EWS functions require an Administrator Login. The default password is “admin”. Functions that require the Administrator Login are shown in *Italics*.

Left-Navigation Item Top Level	Left-Navigation Item Second Level	Display Area Functions	Comments
Top Page		Product Version PostScript Version Engine Version Network Version Serial Number Printer Name Product Name Location Status Display Language Login/Logout	Displays current product configuration information and provides the ability to login as administrator.
Status	Device Status	Paper Input Tray Status Output Tray Status Supply Device Configuration User Flash Status	Provides device status information.
Status	Network Status	General (Network Protocols) TCP/IP (and IP Address) DNS/WINS mDNS IPv6 EtherTalk Netware Email (Send; SMTP) Email (Receive; POP3) SNMP (v1/v2)	Provides network status information.
<i>Status</i>	<i>Power Reset</i>	<i>Reboot Printer</i>	<i>Allows an administrator to reboot the printer.</i>
Document Operations	Job Library	Directory of Job Library Files (Job Retention)	See section “Job Retention and Storage” on page 4-20
Document Operations	Send File	Browse to a file to be sent to the printer.	EWS only feature The types of files that are appropriate for sending with this feature are: Print Data files – this includes any file containing: Simple printable text, PJI/PCL5/PCL6/PS print-data, or PDF (Version 1.3 and earlier) Firmware-Upgrade Files.

Navigating the EWS

Embedded Web Server

Left-Navigation Item Top Level	Left-Navigation Item Second Level	Display Area Functions	Comments
<i>File Management</i>	<i>User Flash</i>	<i>Directory of files in User Flash</i>	<i>EWS only Feature</i> View the files located on the Flash.
System Settings	Total Count	Image Counter Toner Page Count Fuser Counter Usage Count	See section “Understanding Page Counters” on page 3-20
System Settings	Default Settings	Clock Adjust Specify Time Zone Date & Time Settings	Set time and date parameters.
System Settings	Paper Tray Settings	Tray Linking Tray Controls Custom Size Unit	Custom paper size units can be inches or mm. Custom paper size width and length can be set. Note that you must turn Auto-Sense off to set custom sizes. Remember to press the Submit button after each action to gain access to custom size settings.
System Settings	Printer Condition Settings	TAB: Default Settings Copies, Duplex, Duplex Bind, Default Source, Manual Feed, Output Tray, Output Linking, Blank Pages, Auto Resize, Separator Page, Edge to Edge	Common print settings such as number of copies and input and output trays.
System Settings	Printer Condition Settings	TAB: PCL Orientation, Font Source, Font Number, Pitch, Symbol Set, Lines Per Page, CR Mode, LF Mode, FF Mode, Print Area	PCL settings.
System Settings	Printer Condition Settings	TAB: PostScript 3 Print PS Errors	PostScript 3 settings.
<i>System Settings</i>	<i>Operation Settings</i>	<i>Display Language, Power Save, Wait Timeout, Job Timeout, Jam Recovery, Hex Print, Toner Low, Job Accounting</i>	<i>A variety of printer operational settings.</i>
<i>System Settings</i>	<i>Device Control</i>	<i>Resolution, Toner Saver, Print Density</i>	<i>Settings for Resolution, Swing Toner, and Toner Density.</i>
<i>System Settings</i>	<i>Interface Settings</i>	<i>Port, Parallel Setup, Serial Setup, USB Setup</i>	<i>Enable/Disable I/O ports</i>
<i>System Settings</i>	<i>Storing/Calling of System Settings</i>	<i>Factory Defaults, Save Configuration, Restore Configuration</i>	<i>Save and Restore Configuration are EWS only features</i>
<i>Network Settings</i>	<i>Quick Settings</i>	<i>Network Names, DNS Settings, WINS Settings, SMTP Settings</i>	<i>Access to commonly used network settings.</i>

Left-Navigation Item Top Level	Left-Navigation Item Second Level	Display Area Functions	Comments
Network Settings	Protocol Settings	TAB: TCP/IP TCP/IP: TCP/IP, DHCP, IPv6, IP Address, Subnet Mask, Default Gateway	Settings related to the TCP/IP protocol.
Network Settings	Protocol Settings	TAB: Netware Netware: Netware, Mode, Netware Frame PSERVER: Print Server Name, NDS Tree Name, NDS Context, Job Poll Interval NPRINTER: Print Server Name, Remote Printer Number	Settings related to Netware setup.
Network Settings	Protocol Settings	TAB: EtherTalk EtherTalk: EtherTalk, Printer Name, Zone Name	Settings related to EtherTalk setup.
Network Settings	Services Settings	DNS, WINS, mDNS, SMTP, POP3, SNMP	Setup network services.
Trap/Email Alerts	Trap/Email Alert Conditions	Re-send Interval, Offline, Consumable Message, Toner Low/Toner Out, Paper Low/Paper Out, Paper Jam, Cover Open, Offset Catch Error, Mass Storage Error, Recoverable Error, Service Call Required, Usage Report	See chapter "SNMP" on page 8-1.
Job Log	Save/Delete Job Log	Save Job Log Delete Job Log	See section "Job Accounting" on page 4-19
Job Log	View Job Log		See section "Job Accounting" on page 4-19
Security Settings	Password Change		EWS only feature. Change EWS login Administrator password. To reset a lost password XXX.
Security Settings	Port Control	Server Port: HTTP Client Port: SMTP/POP3	Security settings for Server and Client ports.
Security Settings	Filter Setting	IP Filtering Address Ranges/Permissions Administrator Address	See section "IP Filtering" on page 7-3 for a description of IP filtering.
Security Settings	Operator Panel	Console Security	See section "Panel Lock" on page 4-1
Security Settings	Storage Devices	User Flash Erase Cycles RAM Buffer Clear	Security settings for storage devices.

Chapter 7: Networking

The DX-B350P/B450P is a fast network capable printer and supports an Ethernet 10/100 Base-Tx network connection.

Protocols

The following protocols are supported:

TCP/IPv4, UDP, BOOTP, DHCP, ARP, ICMP, DDNS, WINS, LPR
HTTP for Embedded Web Server
IPv6, ICMPv6, Address Auto Configuration and Neighbor Discovery for IPv6
Host Resources MIB (RFC 1514), MIB II (RFC 1213), Printer MIBv2 (3805), SNMPv1/v2
Email SMTP client for alerts, POP3 for receiving print data
Apple EtherTalk, Bonjour
Netware V5.5, V6.5
IPX (SPX/NCP)
LPD

Initial Setting of the Printer's IP Address

All devices on the network must have an IP address. The printer comes configured from the factory to obtain an address automatically from your network's DHCP server. If your network does not support DHCP or you want to set the printer to a specific IP address, you must set it manually.

Setting the IP Address through DHCP

Many networks have a Dynamic Host Configuration Protocol (DHCP) server. A DHCP server automatically programs an IP address into every terminal and printer on the network that is configured to use DHCP. A DHCP server is built into most cable and DSL routers. If you use a cable or DSL router, see your the device documentation for information on IP addressing.

In this Chapter...

- Protocols
- Initial Setting of the Printer's IP Address
- Configuring the Driver
- Printer Network Configuration
- Notifications
- IP Filtering
- IPv6 Implementation
- SNMP

Setting the Network Configuration Manually

You can make changes to the printer's default network configuration using the Operator Panel. Once the settings for DHCP or IP address are changed, the printer automatically re-initializes. To manually set the printer's IP address:

1. Navigate through the menus to the Interface> Network 1 Setup sub menu.
2. Navigate through the Network 1 Setup items to set all of the following items:
 - IP Address
 - Subnet mask
 - Disable DHCP

For more information, see "Interface Menu" on page 3-8.

Setting the IP Address through the Embedded Web Server

The IP Address can also be changed from a computer by using the Embedded Web Server. Prior to using the Embedded Web Server, the printer must have a obtained a valid IP address either through DHCP or manually entered through the Operator Panel.

1. Connect your printer to the network by plugging in the network connector.
2. Turn on your computer and allow it to power up.
3. Print the Configuration Summary by pressing the INFO button. The Configuration Summary lists the printer's IP address.
4. Access the EWS as described in "Accessing the EWS" on page 6-1.
5. In the left navigation area, select Network Settings>Protocol Settings and navigate through the options to get the IP address.

NOTE: You must have administrative access to perform this function.

Configuring the Driver

Once the printer has an IP address, the printer driver can be installed.

1. Connect your printer to the network by plugging in the network connector.
2. Turn on your computer and allow it to power up.
3. Print the Configuration Summary by pressing the INFO button. The Configuration Summary lists the printer's IP address.
4. Install the printer drivers using the CD-ROM included with the printer.
5. At the **Select a Printer Port** installation screen, click the **Add Network Port** button.
6. Enter the printer's IP address and complete the installation as indicated by the installation screens.

Printer Network Configuration

The Operator Panel and the Embedded Web Server allow control of many Network configuration settings.

Network Protocol Configuration

The following protocols can be enabled or disabled:

DHCP
mDNS
SNMP
IPv6
EtherTalk
Netware
HTTP Port Number

I/O Port Configuration

The following I/O ports can be enabled or disabled:

Parallel
Serial
USB
Network Interface

Hub Link Speed/Duplex Configuration

The network interface configuration includes a menu for setting Hub Link Speed and duplex. This menu includes the following settings:

Auto Negotiate (default)
10Base-T Full
10Base-T Half
100Base-T Full
100Base-T Half

Notifications

Automatic notifications of printer unavailability during printing can be sent in the following ways:

SNMP monitoring
E-mail configured via the EWS
Status Monitor Utility.

IP Filtering

The purpose of IP filtering is to limit access to the printer to only those Host computers that have IP addresses within IP ranges predefined on the configuration page. The IP configuration page, accessible from the EWS (when logged in as administrator), has enable and disable parameters. When IP filtering is disabled, all network traffic is allowed.

When IP filtering is enabled and incoming data is from an address that falls within the predefined range, it is allowed to print, if the “Printing” or “Config” checkboxes are checked. If the incoming data does not fall into a predefined range, it is rejected.

In cases where IP ranges overlap but have different permissions (for example, one to print only and another to print and configure), permissions for the overlapping addresses are determined by IP Filter priority. Higher priority overrides lower priority permissions. If an administrator IP address is entered, it takes highest priority over any configured IP range.

NOTE: Leaving IP ranges disables IP Filtering. The address 0.0.0.0 is not allowed.

IPv6 Implementation

Specifications

The IPv6 implementation conforms to the following IETF documents:

RFC 2460: Internet Protocol, Version 6 (IPv6) Specification
RFC 2461: Neighbor Discovery for IP Version 6 (IPv6)
RFC 2462/4862: IPv6 Stateless Address Auto Configuration
RFC 1981: Path MTU Discovery for IP Version 6
RFC 2463/4443: Internet Control Message Protocol (ICMPv6)
RFC 2710/3810: Multicast Listener
Discovery Version 2 (MLDv2)

Operational Information

IPv6 enabled devices can auto configure their IPv6 address. This happens automatically whenever there is an IPv6 enabled router on the subnet to which the device is connected. The printer unique ID is obtained from the Ethernet MAC address. The router may advertise multiple network prefixes, depending on the network configuration. The Network summary page displays all the above addresses, if they exist. If only the Local Link address (starting with "xFE80...") is displayed, that is an indication that the link is not connected to a router (gateway). No manual configuration of IPv6 addresses is supported, nor is there support for DHCPv6, and the printer does not register its IPv6 address with DNS.

Upper Level Protocols such as UDP, TCP run with either IPv4 or IPv6. For instance, a print job can be sent to the printer over IPv4 or IPv6. Similarly the EWS or SNMP can be accessed over IPv4 or IPv6. IPv6 and IPv4 coexist independent of each other. They can be Enabled/Disabled in any combination. They are both enabled by default. In cases where a particular network is configured to run only one IP version, it makes sense to disable the other one (for better resource utilization).

SNMP

SNMP can be used to manage any network device. SNMP is a protocol that allows an SNMP manager (the controller) to control an SNMP agent (the controlee) by exchanging SNMP messages. The main purpose of an SNMP message is to control (set) or monitor (get) the parameters in a network device.

In SNMP, a parameter is an instance of a more generic object. For example, an SNMP agent may have several instances of an object. An SNMP manager can set or get the value for each object instance (each parameter).

In an SNMP agent, parameters are arranged in a tree. SNMP uses an Object Identifier (OID) to specify the exact parameter to set or get in the tree. An OID is a list of numbers separated by periods. An OID is a combination of two values. The first value is the OID of the generic object and the second is the instance value, which specifies the particular instance of the object.

Every SNMP agent has an address book of all its objects, called the MIB or Management Information Base. The MIB provides the name, OID, data type, read/write permissions, and a brief description for each object in an SNMP agent. Armed with information about an object from the MIB, and the instance value, an SNMP manager can send an SNMP message to set or get one of the parameters on an SNMP agent.

Supported Object Identifiers

The printer can be managed via a standard SNMP management station. The printer supports SNMP-v1, SNMP-v2c, MIB-II, Host Resources MIB, and Printer MIB.

Traps

The printer sends generic traps at power up and online and offline traps. Traps are sent on all printer status changes such as: paper out, cover open, tray missing, and jams. The Trap Host ID must be set via the EWS for traps to be enabled.

Hewlett Packard Web Jet Administrative Compatibility

This product operates with HP WebJet Admin in a basic mode where WJA provides generic support for any printer that has Printer MIB implemented. There is no special recognition of this printer by WJA other than that supported by Printer MIB.

SNMP Alerts

Support for SNMP alerts is based on Printer MIB (RFC 1759) requirements. All outstanding alerts are logged into the Printer MIB alert table. Whenever critical alert is entered into the table trap is generated to the Host application. Traps are sent only if Trap Host IP address is defined. It can be set through the EWS under the SNMP setup menu.

Chapter 8: Accessories

The following optional accessories are available for this printer:

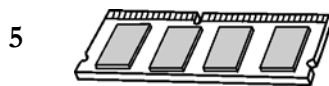
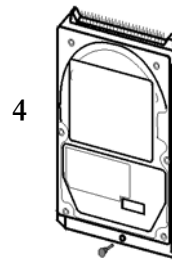
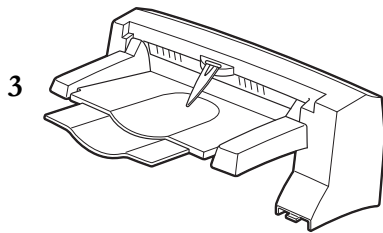
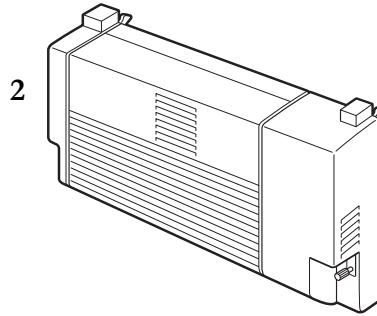
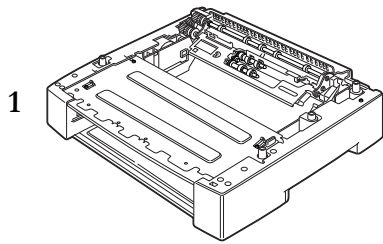

In this Chapter...

- Tray module (A4/ Letter, 550 sheets)
- Paper trays
- Duplex module
- Offset Catch Tray
- Memory Expansion Module
- Hard Disk Drive
- Compact Flash (CF) Card

1. Tray Module (A4/Letter, 550 Sheets) Tray 3, Tray 4
2. Duplex Module
3. Offset Catch Tray
4. Hard Disk Drive
5. Memory Expansion Module
6. Compact Flash (CF) Card

Tray module (A4/Letter, 550 sheets)

Accessories

Tray module (A4/Letter, 550 sheets)

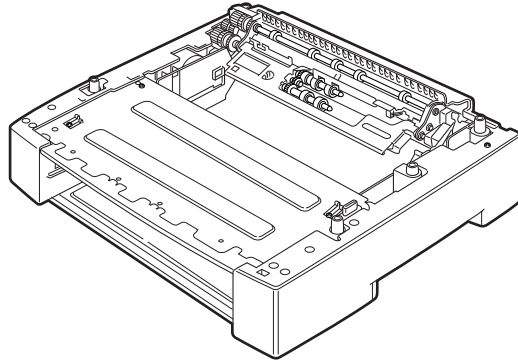

NOTE: You can add up to two Tray Modules.

NOTE: Tray Modules differ by model and can not be interchanged.

Installing/Uninstalling the Tray Module

The optional Tray Module (A4/Letter, 550 sheets) is available for this printer.



CAUTION: Be sure to switch off the power and unplug the power cord from the outlet before carrying out the operations. If not, you might get an electric shock.
When lifting the machine, get a firm footing and bend your knees to avoid possible injuries to your back.

The weight of this printer, without the optional accessories, paper trays, Toner Cartridge and paper, is 22.0 kg/48 lbs. Before moving the printer, you must uninstall the optional accessories first.

When lifting the printer, there should be 2 persons, 1 in front and 1 behind the printer, to firmly grip the recessed areas provided on both sides of the printer. Never try to lift the printer by gripping any other areas. Lifting the printer by gripping any other areas can cause the printer to fall and result in injuries.

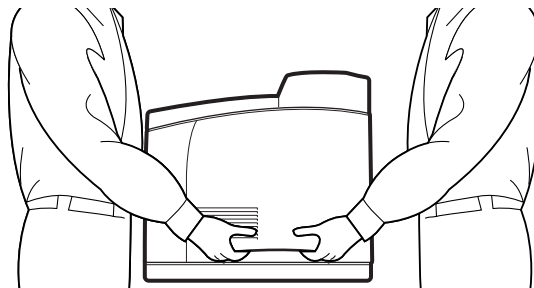

Checking the contents of the tray module package

Before installing the tray module to the printer, ensure that you have all of the following items.

Tray module (A4/Letter, 550 sheets)

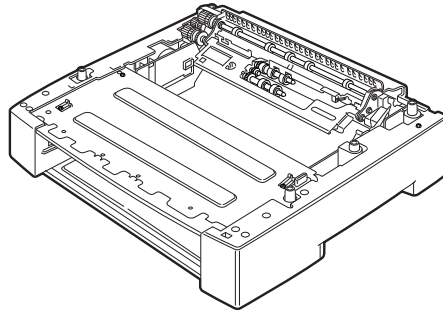

Tray module (A4/550 sheets)

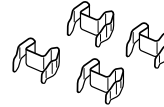

Fasteners (four pieces)

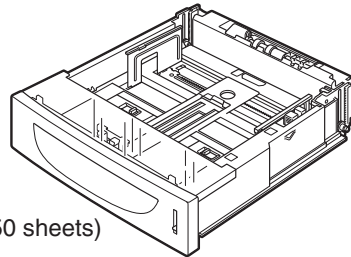

Paper tray (A4/550 sheets)

Installing the Tray Module

1. Place the tray module to be installed at the lowest level on a flat location.

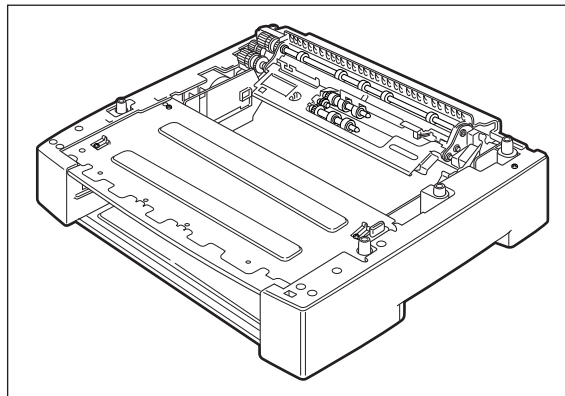

NOTE: Proceed to Step 5 if you are installing only one tray module.

Tray module (A4/Letter, 550 sheets)

Accessories

2. Lift up the tray module to be installed at the top level by holding the parts as shown in the diagram.

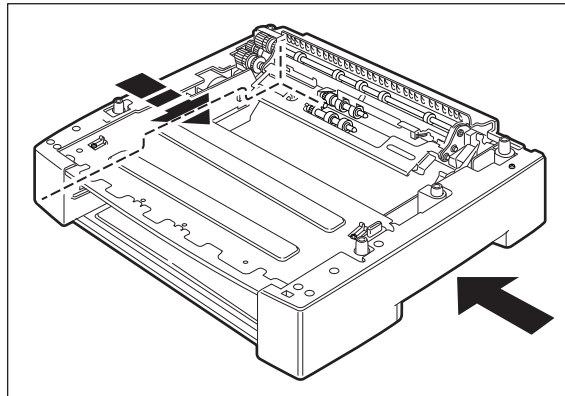

3. Align the front and back corners of the top and bottom tray modules, and slowly lower the top module so that the guide pins at the 4 corners of the bottom module fit into the holes at the base plate of the top module.

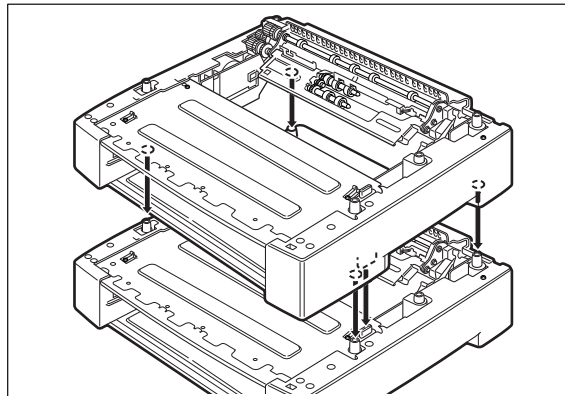

NOTE: The tray module must be lowered gently. Otherwise, the interior parts may be damaged.

4. Insert the fasteners provided into the 2 locations inside of the tray module and 2 locations at the back of the tray module. Insert the fasteners securely.

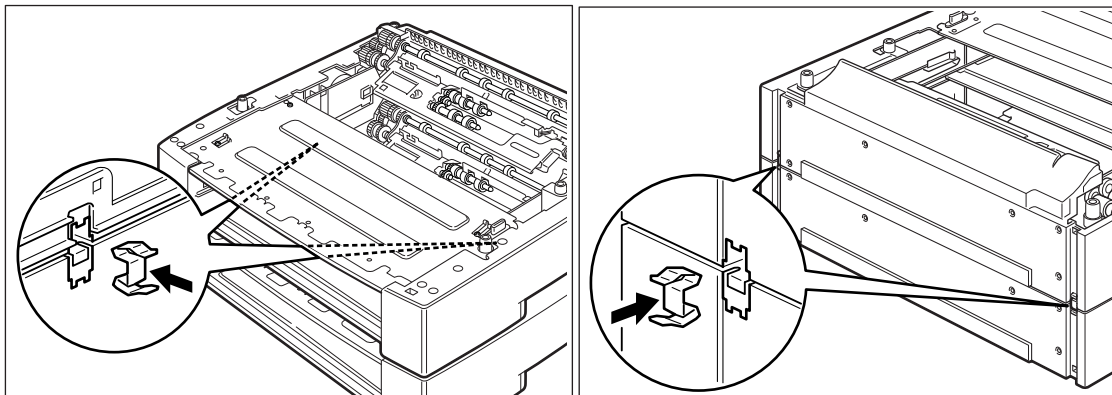

5. Switch off the power to the printer.

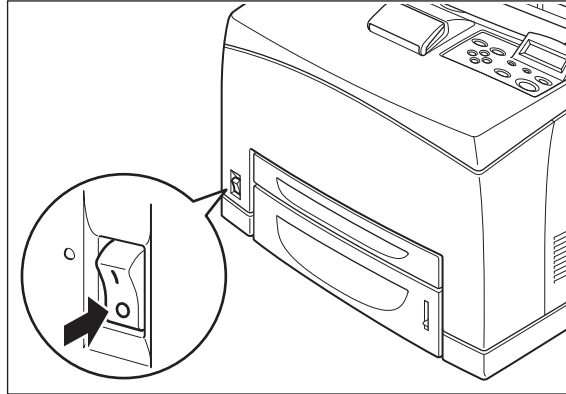

6. Pull out the power cord from the power outlet and then the printer.

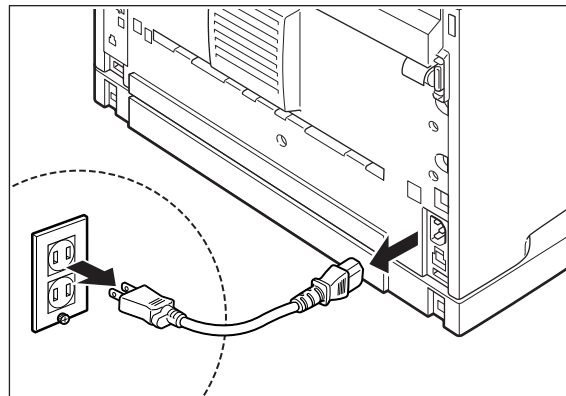

7. Remove any paper in the Standard Output Tray (1) and return the Paper Stop to its original position if it's raised (2).

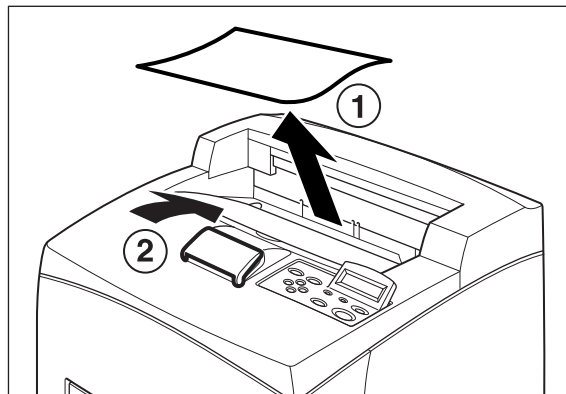

Tray module (A4/Letter, 550 sheets)

Accessories

8. Pull the paper tray out of the printer.

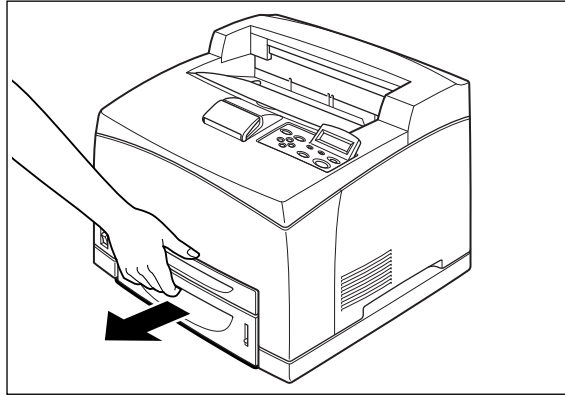

9. Lift up the printer by holding the recessed areas as shown in the diagram.

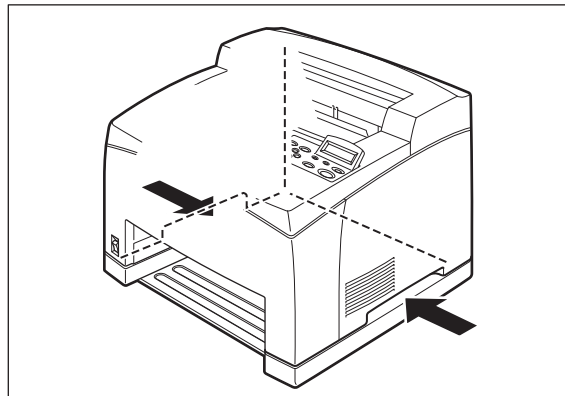

10. Align the corners of the printer and the tray modules, and lower the printer gently so that the guide pins at the 4 corners of the tray modules fit into the holes at the base plate of the printer.

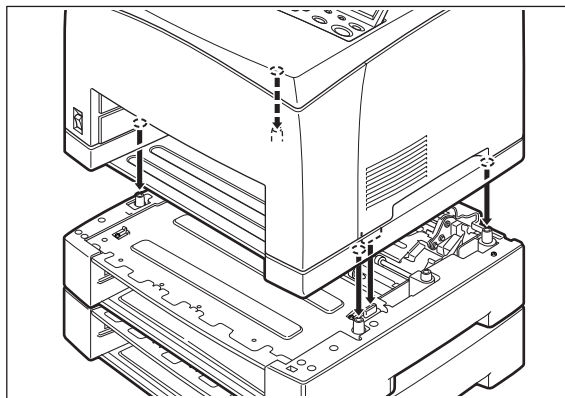

NOTE: The printer must be lowered gently. Otherwise, the interior parts may be damaged.

11. Insert the fasteners provided into the 2 locations inside and 2 locations at the back of the printer. Insert the fasteners securely.

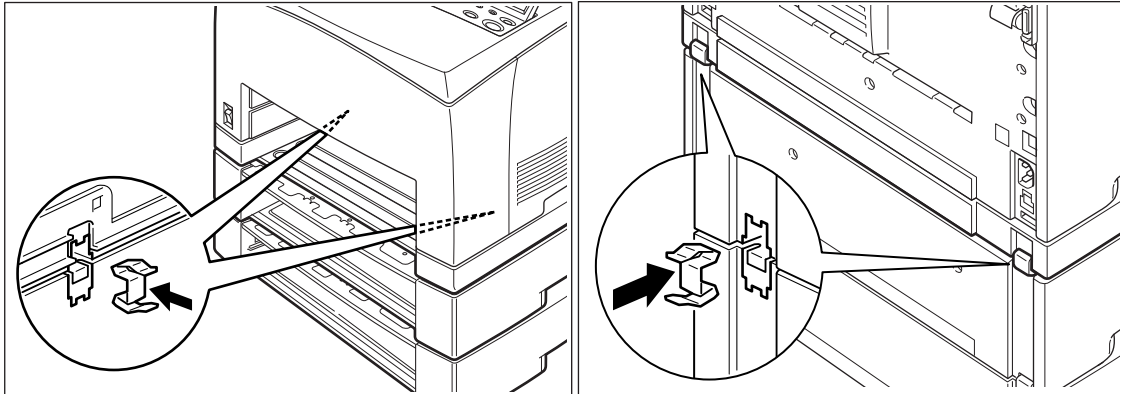

12. Push the paper tray completely into the printer.

Uninstalling the Tray Module

NOTE: This procedure explains the uninstalling of two tray modules as an example. You can use the same procedure for uninstalling one tray module.

1. Switch off the power to the printer.

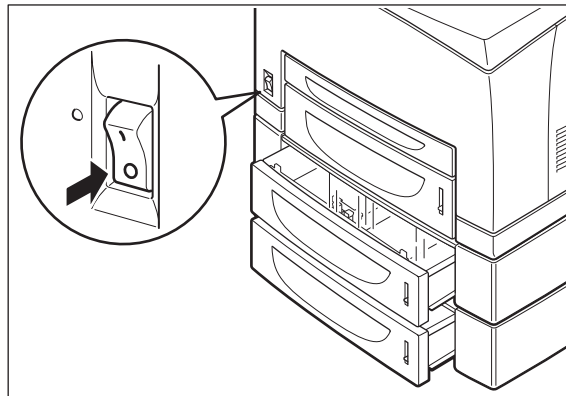

2. Pull out the power cord from the power outlet and then the printer.

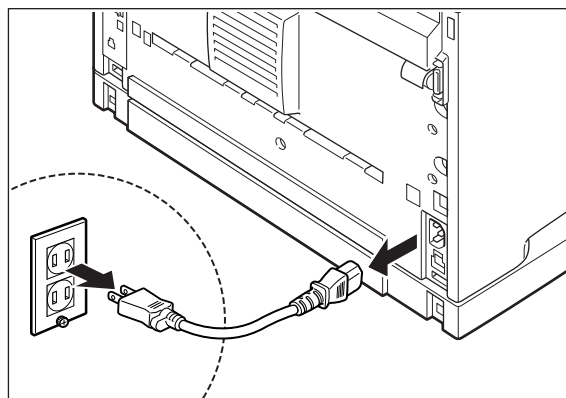

Tray module (A4/Letter, 550 sheets)

Accessories

3. Remove any paper in the Standard Output Tray (1) and return the Paper Stop to its original position if it's raised (2).

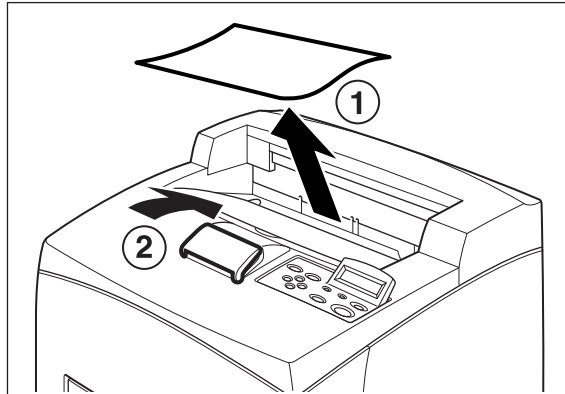

4. Pull the paper tray out of the printer.

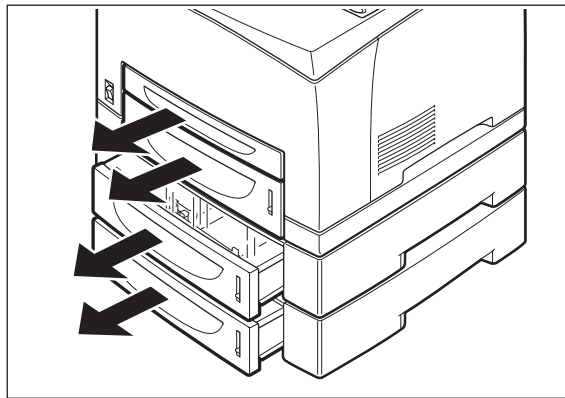

5. Remove the fasteners found at the 2 locations inside and at the 2 locations at the back of the printer.

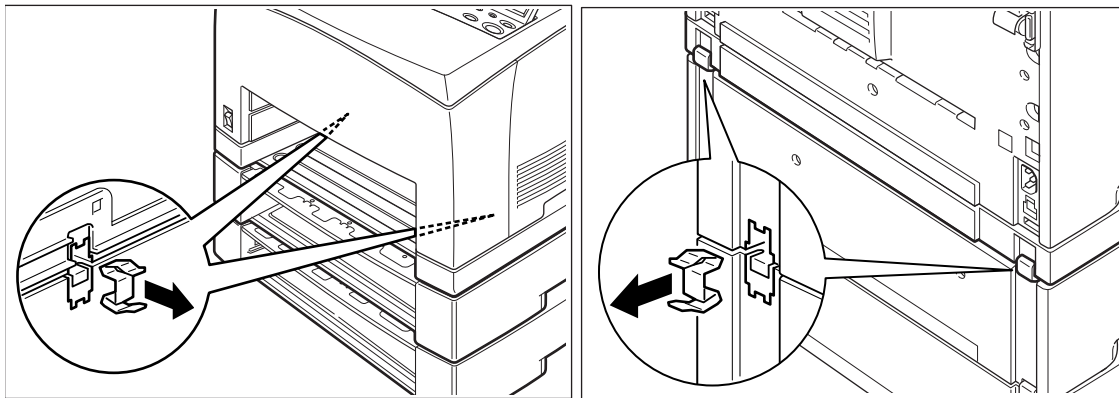

- Lift up the printer by holding the recessed areas as shown in the diagram and then remove it from the tray modules.

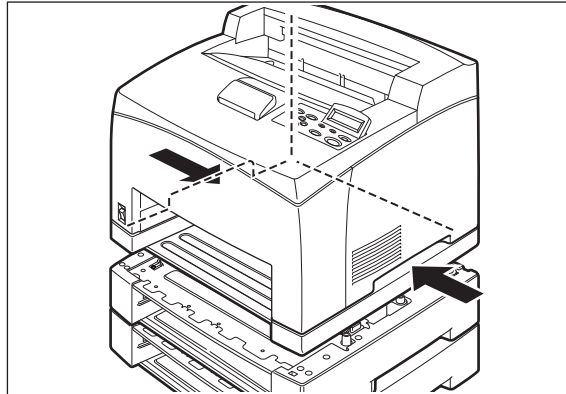

- Remove the fasteners found at the 2 locations inside the tray modules and at the 2 locations at the back of the tray modules.

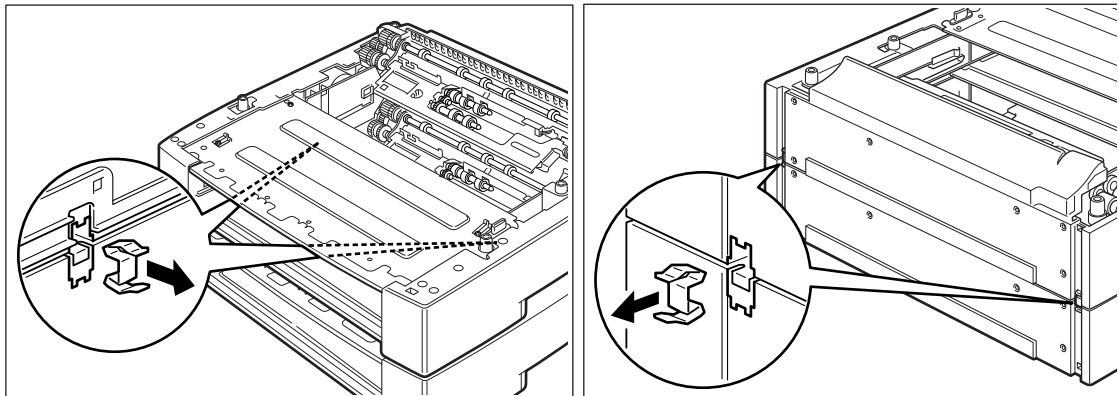

- Lift up the top tray module by holding the recessed areas as shown in the diagram and then remove it from the bottom tray module.

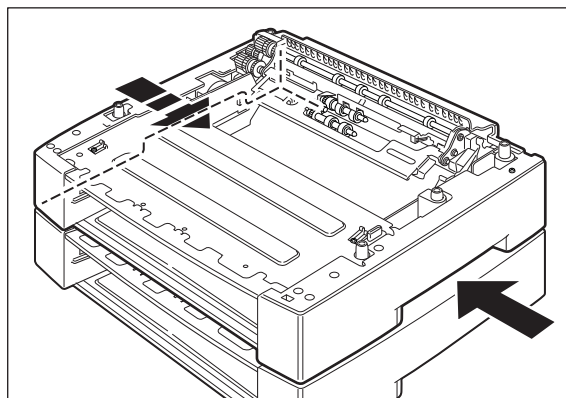

Paper trays

Accessories

Paper trays

Paper tray (A4/Letter, 550 sheets)

This Tray Module is interchangeable with the standard Tray 2.

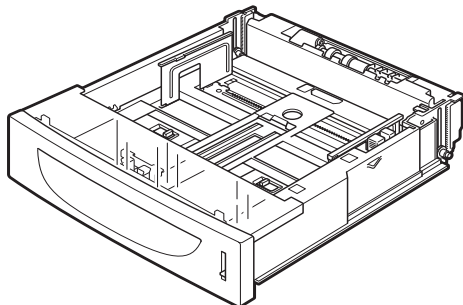

Duplex module

Install this module to the printer to enable 2-sided printing.

NOTE: Although there are different duplex modules for the DX-B350P and DX-B450P models, installation of these modules is the same. The DX-B450P Duplex module is slightly larger and weighs more than the DX-B350P model Duplex module.

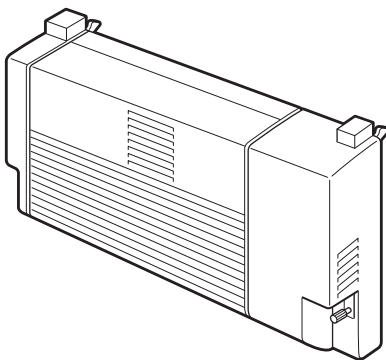

CAUTION: Be sure to switch off the power and unplug the power cord from the outlet before carrying out the operations. If not, you might get an electric shock.

Installing the Duplex Module

1. Switch off the power of the printer.

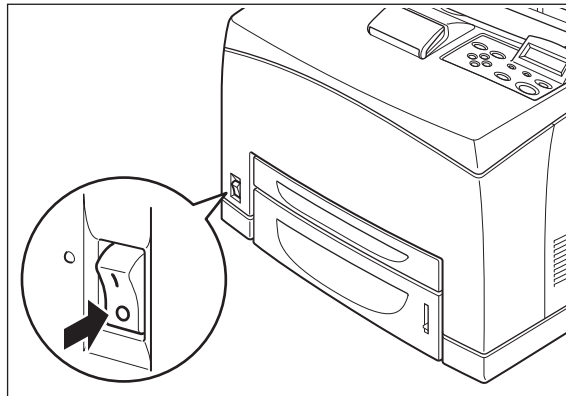

2. Pull out the power cord from the power outlet and then the printer.

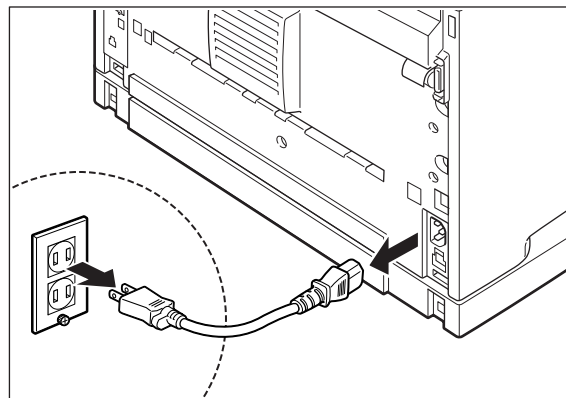

3. Remove the rear cover of the printer after pushing the two tabs as shown in the diagram. Next, remove the connector cover of the printer as shown in the diagram.

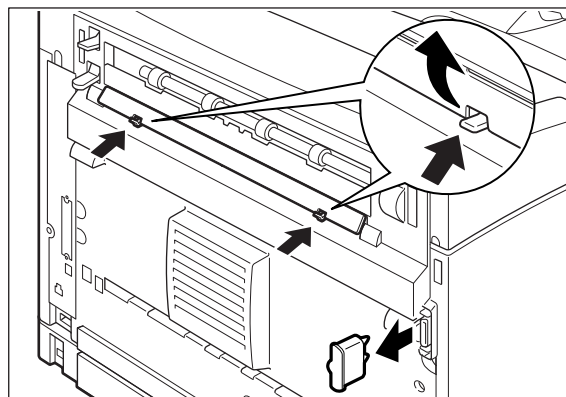

Duplex module

Accessories

4. Insert the right and left tabs at the bottom of the duplex module into the holes at the back of the printer and then align the top part of the duplex module with the printer. Ensure that the connector of the duplex module is connected to the connector of the printer.

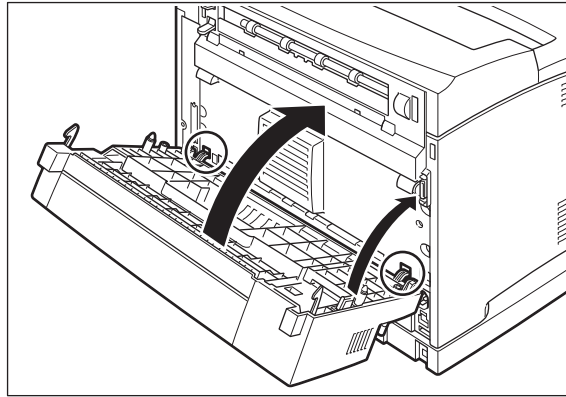

5. Tighten the screws at the both ends of the bottom of the duplex module.

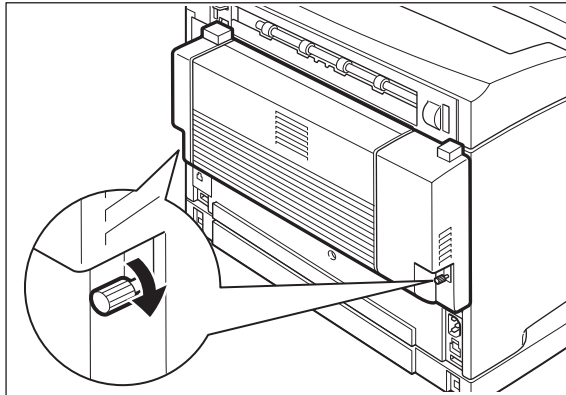

Uninstalling the Duplex Module

1. Switch off the power to the printer.

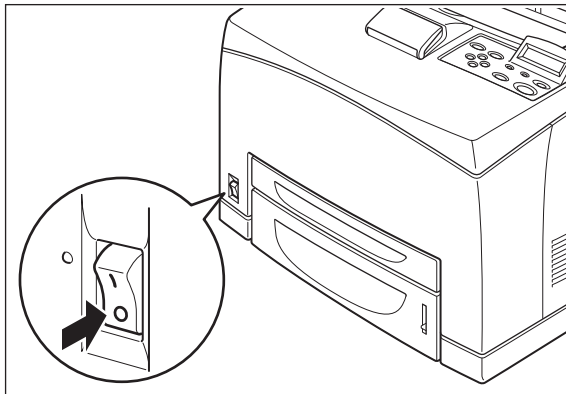

2. Pull out the power cord from the power outlet and then the printer.

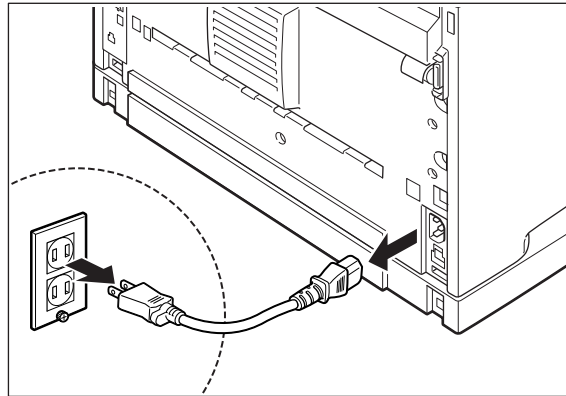

3. Loosen the screws at the both ends of the bottom of the duplex module.

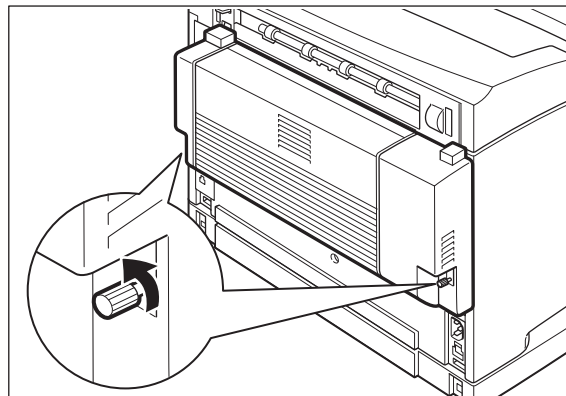

4. While supporting the duplex module with your hand, lift the lever at the top left hand side of the duplex module to unlock it and then tilt the top part of the duplex module away from the printer.

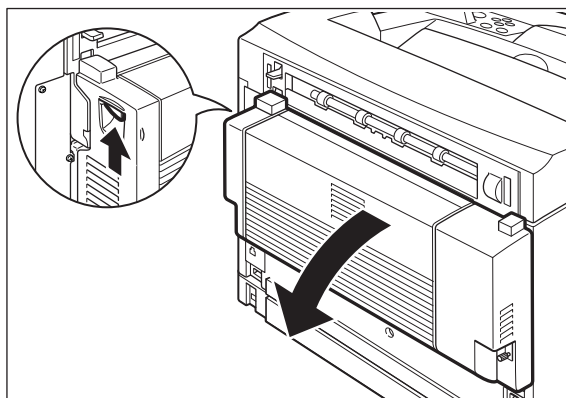

NOTE: You must support the duplex module with your hand as once it is unlocked. Otherwise, it may fall.

Offset Catch Tray

Accessories

5. While holding up the duplex module, remove the right and left tabs of the duplex module from the holes at the back of the printer.

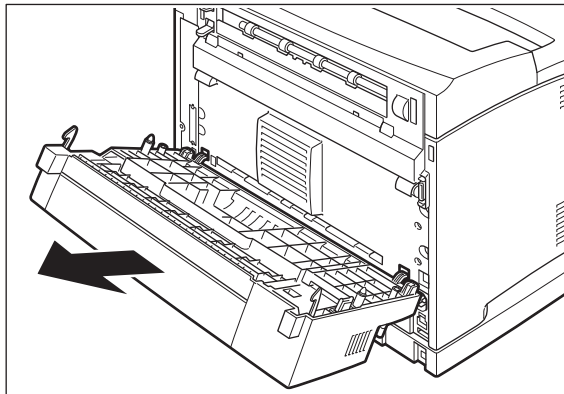

6. Push in the cover and connector cover, which were removed during installation of the duplex module, until it clicks into the back of the printer.

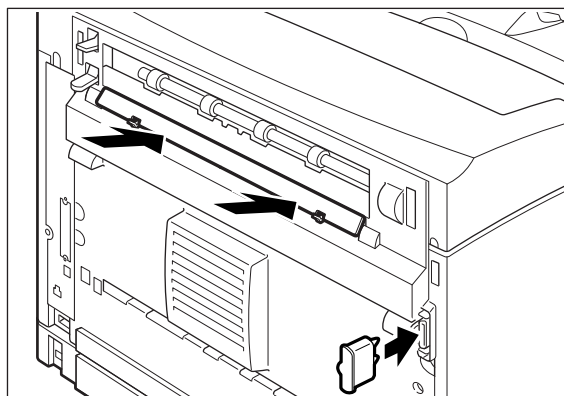

Offset Catch Tray

Install this tray to the printer to enable print jobs to be offset. Maximum capacity is 500 sheets.

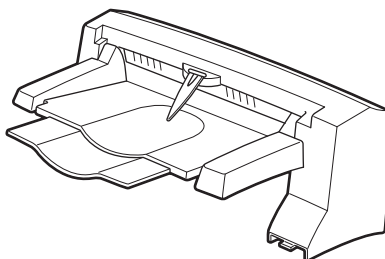

Installing/Uninstalling the Offset Catch Tray

You can install an optional Offset Catch Tray to this printer.



CAUTION: Be sure to switch off the power and unplug the power cord from the outlet before carrying out the operations.

Installing the Offset Catch Tray

1. Switch off the power to the printer.

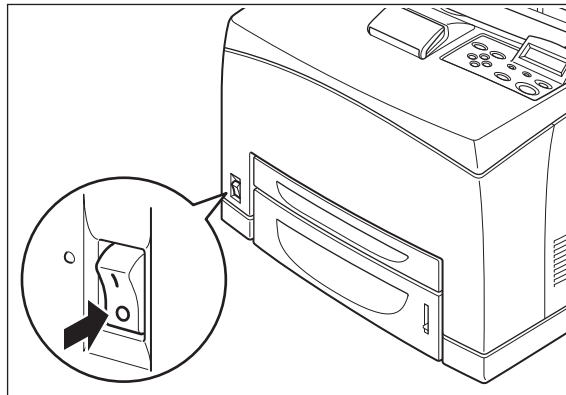

2. Pull out the power cord from the power outlet and then the printer.

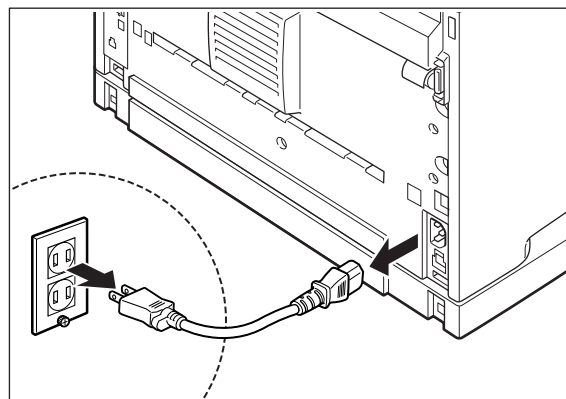

3. Lift up the second lever from the top left corner of the back of the printer.

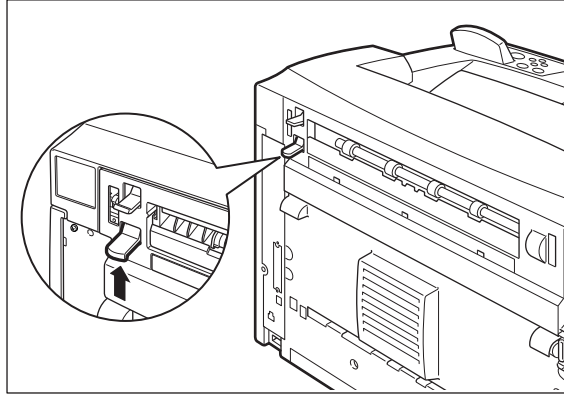

4. Open the rear cover.

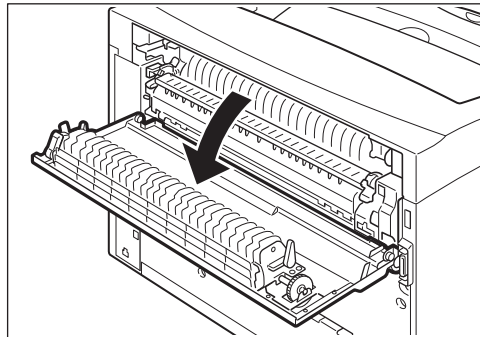

NOTE: Do not touch any parts inside the printer.

5. Loosen the right and left thumb screws as shown in the diagram to uninstall the top cover of the paper exit.

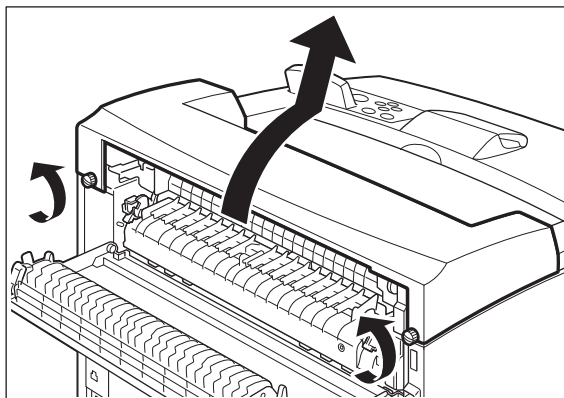

6. Insert the right and left tabs of the Offset Catch Tray into the holes at the top of the printer (1) and put it down to the top of the printer slowly (2).

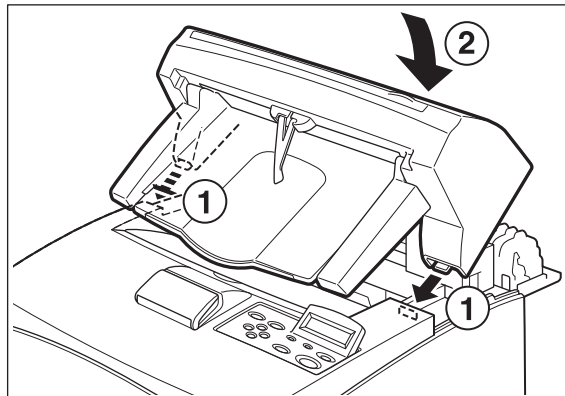

7. Secure the screws at both ends of the bottom of the Offset Catch Tray.

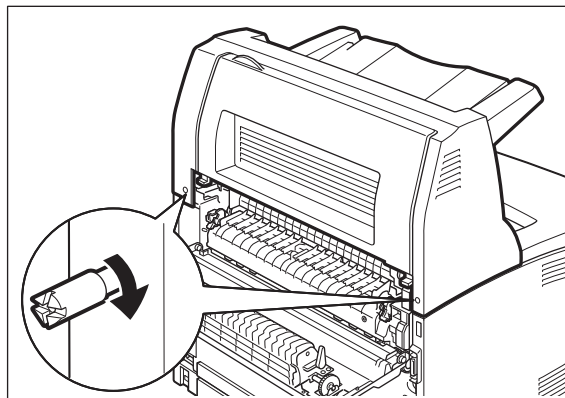

8. Pull out the extension tray.

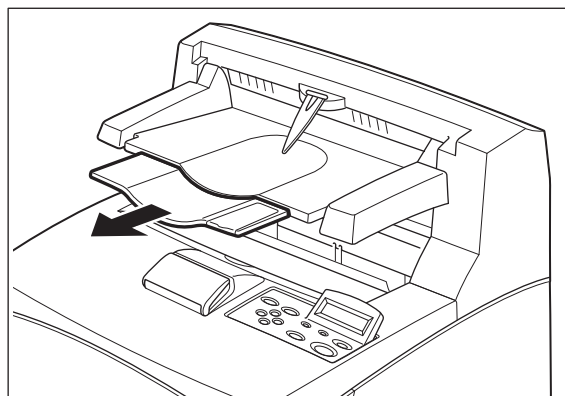

9. Close the rear cover.

Uninstalling the Offset Catch Tray

1. Switch off the power to the printer.

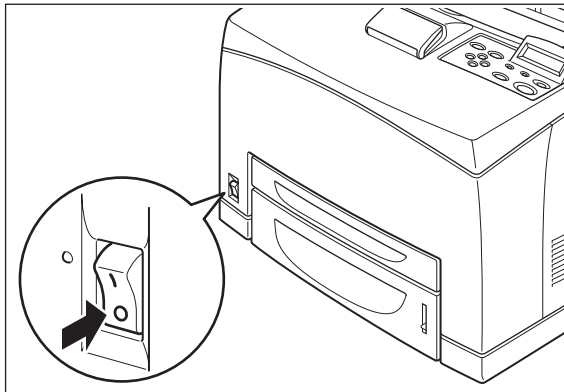

2. Pull out the power cord from the power outlet and then the printer.

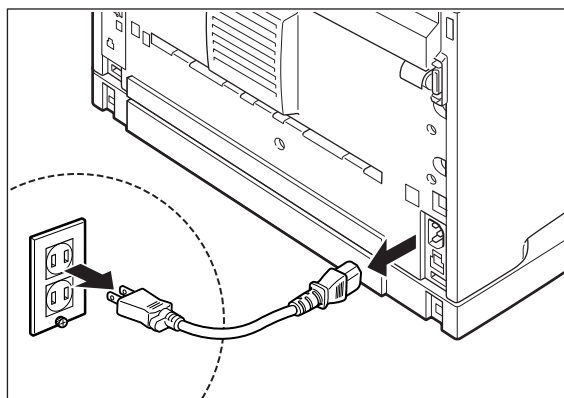

3. Close the stopper and the extension tray of the Offset Catch Tray.

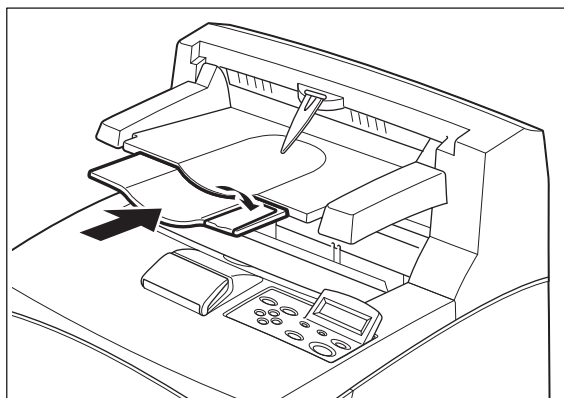

4. Lift up the second lever (1) from the top left corner of the back of the printer to open the rear cover (2).

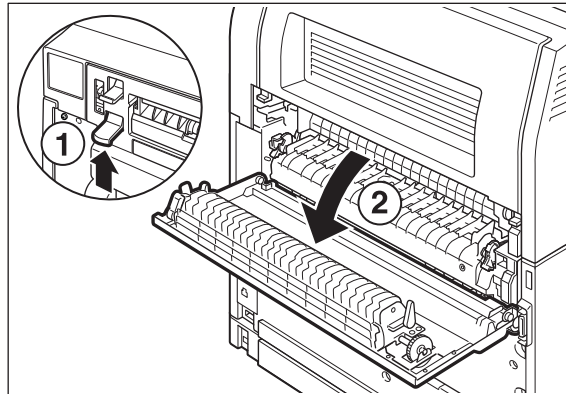

5. Remove the screws on both sides of the Offset Catch Tray (1), and while holding up the Offset Catch Tray, remove the right and left tabs from the holes at the top of the printer (2).

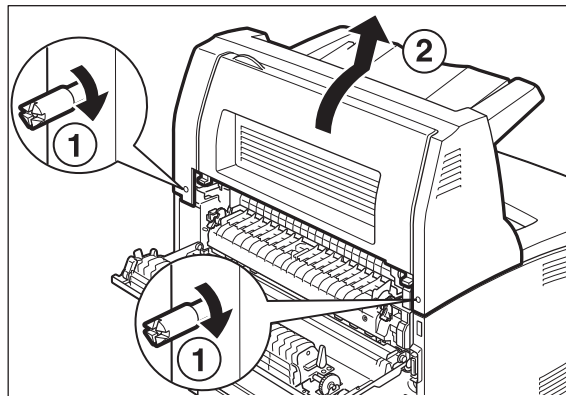

6. Fasten the right and left thumb screws of the top cover of the paper exit, which was removed during installation of the Offset Catch Tray, into the holes at the top of the printer.

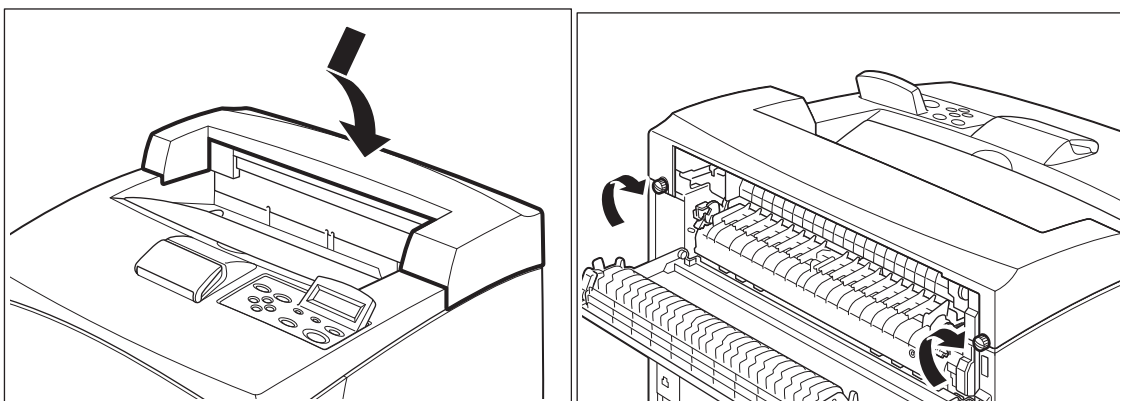

Memory Expansion Module

1. Ensure that the printer power switch is set to the OFF <O> position.
2. Disconnect the power cord from the wall outlet.
3. Remove the side cover from the printer.
4. Remove the inside panel by removing the screws as shown below:



5. Pull the inside panel away from the printer by the top edge.
6. Carefully insert a Memory Module into the slot as shown below. When properly seated, gently push down on the module until the side braces close onto the ends of the Memory Module.



7. Reinstall the side covers in reverse order (Steps 3, 4, and 5).
8. Connect the power cord to the wall outlet. Turn the printer power switch to the ON <I> position.

Hard Disk Drive

1. Ensure that the printer power switch is set to the OFF <O> position.
2. Disconnect the power cord from the wall outlet.
3. Remove the inside panel (see “Memory Expansion Module” on page 8-20).
4. Locate the area of the controller identified as “Hard Disk”. Ensure that there is a plastic female insert fitted into the board into which the supplied plastic rivet can be fitted in stage 8. Align the hard disk within the designated area and gently move up to ensure the 44-pin male connector of the hard disk is connected to the 44-pin female connector on the controller assembly.
5. Be sure to align the Hard Drive as depicted by the alignment drawing on the controller, making sure that the two top pins to the left of the connector are free standing and not connected. Your Hard Disk comes with a mounting bracket installed. This must be in place to help guide the disk into the correct pins and to secure the disk in place.
6. If there is improper alignment, remove the Hard Drive and reinstall.



NOTE: Improper alignment will damage the hard drive and the printer.

7. Insert the plastic rivet through the aligned hole until it clicks.



8. Reinstall the covers in reverse order (see “Memory Expansion Module” on page 8-20–Steps 3, 4, and 5).

Compact Flash (CF) Card

Accessories

9. Connect the power cord to the wall outlet. Turn the printer power switch to the ON <I> position. When ready the printer may advise to press the select key to format the hard drive. This has to be done so that the hard drive can be used.

The installation of your Hard Disk option in your printer is now complete.

Compact Flash (CF) Card

1. Carefully review the safety precautions in the front of this guide before starting this installation procedure.
2. Ensure that the printer power switch is set to the OFF <O> position.
3. Disconnect the power cord from the wall outlet.
4. Remove the inside panel (see “Memory Expansion Module” on page 8-20).
5. Locate the CF socket as shown below. Align the CF Card with the socket and carefully insert the card. Carefully align the Compact Flash card to the socket so that the notch on both sides of the Compact Flash are uppermost and insert into the socket.

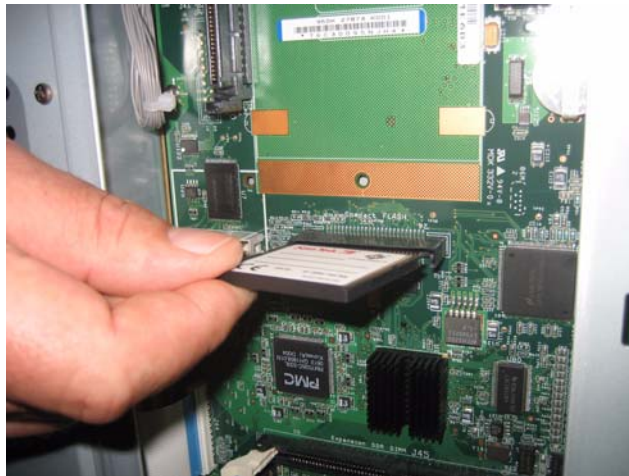

6. Reinstall the side covers in reverse order (see “Memory Expansion Module” on page 8-20– Steps 3, 4, and 5).
7. Connect the power cord to the wall outlet. Turn the printer power switch to the ON <I> position.
8. When ready, the printer may advise to press the select key to format the Compact Flash. The installation of the CF Card option in your printer is now complete.

Chapter 9: Troubleshooting

This chapter provides information to help you troubleshoot problems. It explains what to do if the printer is not printing at all, is not printing correctly, or if error messages are displayed.

In this Chapter...



- Poor Print Quality
- No Power
- Cannot Print
- Printing is Not Clear
- Paper Incorrectly Fed
- Noise
- Error and Warning Messages

Poor Print Quality

Troubleshooting

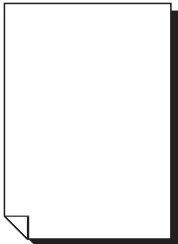

Poor Print Quality

Paper Is Output Blank or All Black

Status	Items to check	Action
Nothing is printed. 	Is the seal of the Toner Cartridge pulled out?	Pull out the seal.
	Are two or more sheets of paper fed simultaneously?	Remove and fan the papers well. Then load them again.
	Is the Toner Cartridge defective or damaged?	Replace it with a new Toner Cartridge.
	Is the Toner Cartridge correctly set?	Reset the Toner Cartridge correctly.
	Printer may have malfunctioned.	Contact Technical Support.
The entire paper is printed black. 	Is the Toner Cartridge defective or damaged?	Replace it with a new Toner Cartridge.
	Printer may have malfunctioned.	Contact Technical Support.

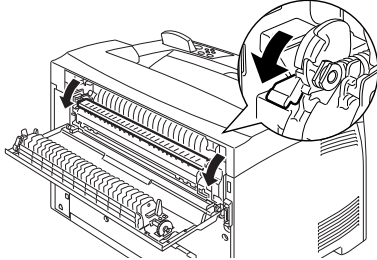

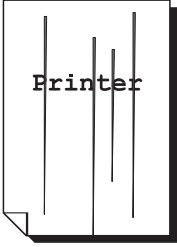
Printout Is Faded, Stained, Missing, Wrinkled, or Blurred

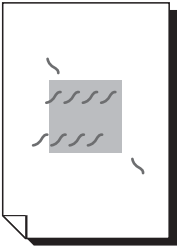
Status	Items to check	Action
Printing is faded and blurred. 	Is the correct type of paper used?	Load the correct type of paper.
	Is the paper damp?	Replace with paper from a new ream.
	Is the Toner Cartridge defective or damaged?	Replace with a new Toner Cartridge.
	Is it time to replace the Toner Cartridge?	Replace with a new Toner Cartridge.
	Are the levers at both ends of the Fuser Unit pushed up?	Push down the levers. 

Status	Items to check	Action
<p>Black spots are printed.</p> 	<p>Is the correct type of paper used?</p> <p>Is the Toner Cartridge defective or damaged? Ensure that you are not printing outside the non printable area. This is within 4 mm of the paper edge</p>	<p>Load the correct type of paper.</p> <p>Replace it with a new Toner Cartridge.</p>
<p>Black streaks are printed.</p> 	<p>Is the Toner Cartridge defective or damaged?</p>	<p>Replace it with a new Toner Cartridge.</p>
<p>Dirt appears at equal intervals.</p> 	<p>The feed route of the paper may be stained.</p> <p>Is the Toner Cartridge defective or damaged?</p>	<p>Print a few pages to remove the stains.</p> <p>Replace it with a new Toner Cartridge.</p>
<p>Hair-like streaks are printed inside or outside the black halftone areas.</p> 	<p>Are you using paper that has been left unwrapped for a long period of time (especially when the humidity is low)?</p>	<p>Replace with paper from a new ream.</p>

Poor Print Quality

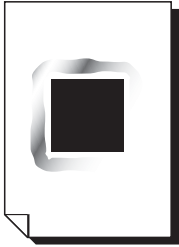
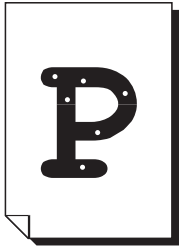
Troubleshooting

Status	Items to check	Action
<p>Shadows are printed around black filled areas.</p> 	<p>Are you using paper that has been left unwrapped for a long period of time (especially when the humidity is low)?</p>	<p>Replace with paper from a new ream.</p>
<p>White dots appear in black filled areas.</p> 	<p>Is the correct type of paper used?</p>	<p>Load the correct type of paper.</p>
	<p>Is the Toner Cartridge defective or damaged?</p>	<p>Replace it with a new Toner Cartridge.</p>
<p>Printed image smudges when rubbed with your finger.</p> 	<p>Is the paper damp?</p>	<p>Replace with paper from a new ream.</p>
	<p>Is the correct type of paper used?</p>	<p>Load the correct type of paper.</p>
<p>Printed image appears partially blank.</p> 	<p>Is the paper damp?</p>	<p>Replace with paper from a new ream.</p>
	<p>Is the correct type of paper used?</p>	<p>Load the correct type of paper.</p>

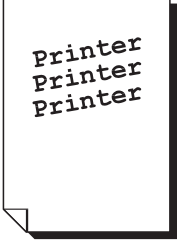
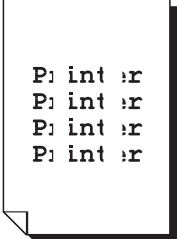
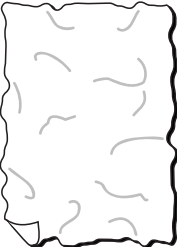
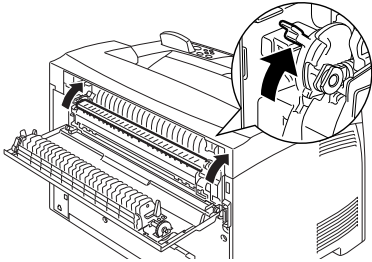
Status	Items to check	Action
<p>Image is printed at an angle. Image is printed at an unexpected location.</p> 	<p>Are the paper tray guides set in the correct positions?</p>	<p>Set the length guide and width guide in the correct positions.</p>
<p>Vertical blanks appear.</p> 	<p>Is the Toner Cartridge correctly set? Is the Toner Cartridge defective or damaged?</p>	<p>Reset the Toner Cartridge correctly. Replace it with a new Toner Cartridge.</p>
<p>Paper is wrinkled.</p> 	<p>Is the correct type of paper used? Is the paper damp? Is the paper correctly set?</p>	<p>Load the correct type of paper. Replace with paper from a new ream. Load the paper correctly.</p>
<p>Envelopes are wrinkled.</p>	<p>Envelopes may be wrinkled depending on the type used.</p>	<p>Open the rear cover of the printer and push up the levers at both ends of the Fuser Unit. Wrinkles can be reduced.</p>  <p>After printing the envelopes, you must return the levers to their original positions.</p>

No Power

Troubleshooting

Status	Items to check	Action
Text is blurred. 	Is the paper damp?	Replace with paper from a new ream.
	Is the correct type of paper used?	Load the correct type of paper.

No Power

Status	Items to check	Action
There is no power.	Is the power switched off?	Press the printer switch to the <I> position to turn the power on.
	Is the power cord disconnected or not securely connected?	Switch off the power and connect the cord to the power outlet and printer again. Then, switch on the power.
	Is the power cord connected to a power outlet with the correct voltage?	Connect the printer exclusively to an outlet with a suitable voltage rating and current rating.
Power is interrupted frequently.	Printer may have malfunctioned.	Switch off the power to the printer, remove the plug from the power outlet and contact Technical Support.
	Is the power cord disconnected or not securely connected?	Switch off the power and connect the cord to the power outlet and printer again. Then, switch on the power.

Cannot Print

Status	Items to check	Action
Print instruction was sent but processing did not start.	Is the fault indicator lit? Is the print-ready indicator off?	Carry out the action according to the status of the indicator.
	Is there any message displayed on the Operator panel?	Check the message, then carry out the action.
	Is there any message displayed in the computer?	Check the message, then carry out the action.

Printing is Not Clear

Status	Items to check	Action
Transparencies are not printed clearly.	Are the correct type of transparencies used?	Load the correct type of transparencies.
	Are the transparencies correctly loaded in the paper tray?	Load the transparencies correctly in the paper tray.
Postcards are not printed clearly.	Are the correct type of postcards used?	Load the correct type of postcards.
	Are the postcards correctly loaded in the paper tray?	Load the postcards correctly in the paper tray.
Envelopes are not printed clearly.	Are the correct type of envelopes used?	Load the correct type of envelopes.
	Are the envelopes correctly loaded in the paper tray?	Load the envelopes correctly in the paper tray.

Paper Incorrectly Fed

Status	Items to check	Action
Paper cannot be fed. Paper jams occur. Multiple sheets of paper are fed. Paper is fed at an angle.	Is the paper correctly set?	Load the paper correctly. For transparencies, postcards or envelopes, fan them well first to allow air to enter between each sheet before loading.
	Is the paper damp?	Replace with paper from a new ream.
	Is the correct type of paper used?	Load the correct type of paper.
	Is the paper tray pushed in?	Push the paper tray completely into the printer.
	Is the paper jammed?	Remove the jammed paper.
	Is the printer placed on a flat location?	Place the printer on a stable surface.
	Are the paper tray guides set in the correct positions?	Set the length guide and width guide in the correct positions.
	Did you print any picture postcards?	Clean the feed roll.

Noise

Troubleshooting

Noise

Status	Items to check	Action
Strange noise occurs.	Is the printer placed on a flat location?	Shift the printer to a stable surface.
	Is the top cover open?	Close the top cover tight.
	Is the paper tray pushed in?	Push the paper tray completely into the printer.
	Are there foreign objects inside the printer?	Switch off the power and remove any foreign objects inside the printer. If the object cannot be removed unless the printer is disassembled, contact Technical Support.

Error and Warning Messages

Your printer's Operator Panel provides you with information and troubleshooting help. When an error or warning condition occurs, the Operator Panel displays a message informing you of the problem.

Warning Messages

The following table lists warning messages, possible causes, and the actions required to correct each cause. When Warning messages are displayed, the printer continues to operate.

Warning Message Line 2 of display	Possible Cause	Action
Paper Out Tray 1	There is no paper in Tray 1.	Add paper to the tray.
Paper Out Tray 2	There is no paper in Tray 2.	Add paper to the tray.
Paper Out Tray 3	There is no paper in Tray 2.	Add paper to the tray.
Paper Out Tray 4	There is no paper in Tray 4.	Add paper to the tray.
Output Tray Full	The Standard Output Tray is full.	Remove paper from the tray.
Offset Tray Full	The Offset Catch Tray is full.	Remove paper from the tray.
Toner Low	The toner is low.	Replace the Toner Cartridge soon. Users can press the Start button to continue printing with low toner. See "System Menu" on page 3-15 for more information.

Error Messages

The table below lists error messages, the possible causes of each error, and the actions required to recover from each error. When Error messages are displayed, the printer stops printing and user intervention is required before printing can continue.

Error Message Line 1	Error Message Line 2	Possible Cause	Action
Exit Jam Offset Tray Jam Duplex Jam	Remove Paper	There is a paper jam inside the printer.	Remove the jammed paper from the indicated location.
Cover Open	Close Top Cover	The top cover is open.	Close the top or rear cover.
Cover Open	Close Rear Cover	The rear cover is open.	Close the rear cover.
Cover Open	Close OCT Cover	The offset tray cover is open.	Close the offset tray cover.
Ready	Tray 1 Missing	Tray 1 is not in the printer.	Insert the tray.
Ready	Tray 2 Missing	Tray 2 is not in the printer.	Insert the tray.
Ready	Tray 3 Missing	Tray 3 is not in the optional feeder.	Insert the tray.
Ready	Tray 4 Missing	Tray 4 is not in the optional feeder.	Insert the tray.
Load Paper Tray1	Paper Size/Paper Type	Tray 1 is empty.	Load paper into the tray.
Load Paper Tray2	Paper Size/Paper Type	Tray 2 is empty.	Load paper into the tray.
Load Paper Tray3	Paper Size/Paper Type	Tray 3 is empty.	Load paper into the tray.
Load Paper Tray4	Paper Size/Paper Type	Tray 4 is empty.	Load paper into the tray.
Paper Size Error	Paper Size/Press Start	The paper size is not supported by the printer.	Check paper size specifications and load paper that meets specifications.
Output Tray Full	Remove Paper	The Standard Output Tray is full.	Remove paper from the tray.
Offset Tray Full	Remove Paper	The Offset Catch Tray is full.	Remove paper from the tray.
Toner Missing	Install/Reset	The Toner Cartridge is missing or not installed correctly.	Install the Toner Cartridge or reinstall the toner correctly.
ID Mismatch		Wrong Toner Cartridge is installed.	Remove Toner Cartridge and install the correct one.
Restart Printer			Press the next key several times noting all the numbers shown. Power the printer off and wait 30 seconds and power on again. Contact your printer support desk if the error reoccurs quoting the numbers displayed.

Error and Warning Messages

Troubleshooting

Error Message Line 1	Error Message Line 2	Possible Cause	Action
ROS Failure	Call Service	The ROS has failed.	Turn the printer off, then turn it on. If the problem reoccurs, contact an authorized service provider.
Fuser Failure	Call Service	The fuser has failed.	
Offset Tray Fail	Call Service	The offset tray was removed or has failed.	
Duplex Failure	Call Service	The duplexer was removed or has failed.	
Main Motor Fail	Call Service	The main motor has failed.	
Engine Nv Fail	Call Service	The engine has failed.	
Fan Failure	Call Service	The fan has failed.	
Offset Tray Fail		OCT Error. Offset Catch Tray failure	Call Service
Toner Low		Toner Cartridge reaching end of life	Replace cartridge
Canceling Job	Consuming xxx	Printer has received a command to cancel the current job.	None
Code FLASH Error	Upgrade Firmware	The printer has detected that the operating code is corrupt.	Reload the printer flash code via the parallel port.
CF Unformatted	Select To Format	An unformatted Compact Flash option was installed	Press Select to format the CF
DISK Error	SELECT To Format	An unformatted hard disk option was installed	Press Select to format the disk
File Error 00 through	File Error 25	Firmware Upgrade error	Check firmware file
	File Error 26	Firmware Upgrade error: Bad header	Transmission error: check cabling and restart
	File Error 27	Firmware Upgrade error: Bad checksum	Transmission error: check cabling and restart
	File Error 29	Firmware Upgrade error: Wrong printer type	Firmware is for wrong printer
Initializing		Second stage of printer boot cycle	None Normal Printer Operation
IPADDR Collision	Press Start	The IP address in the printer is duplicated on the network	Have the network administrator check assigned addresses
JOBLIB Error 01	Press Start	JobLibrary datastream missing a Job Name.	Ensure the Job Name is entered
JOBLIB Error 02	Press Start	JobLibrary datastream missing a User Name	Ensure the User Name is entered

Error Message Line 1	Error Message Line 2	Possible Cause	Action
JOBLIB Error 03	Press Start	JobLibrary private mode datastream missing PIN.	Ensure the PIN is entered
JOBLIB Error 04	Press Start	JobLibrary datastream attempted to overwrite a Private job, but PIN did not match.	Ensure the PIN matches or change the Job Name
JOBLIB Error 05	Press Start	JobLibrary has insufficient storage	Delete unneeded files from the printer disk
Load Paper Tray x	Media size and type	The requested size and type of paper was not sensed in the tray	Load paper of the size and type noted. Use the Status key to check that paper size and type is correct for the tray.
Loading		First stage of printer boot cycle	None Normal Printer Operation
Maintenance Req'd		Printer has reached the maintenance interval of 200,000 pages.	Press Start to acknowledge the condition. Please contact your dealer or authorized service representative for assistance in maintenance.
Mem Size Changed	xxxM (Was xxxM)	Printer recognizes that optional memory was installed or removed	Press Start to acknowledge
Net1: Comm Error	Press Start	Communications error with optional interface	Remove the optional interface and restart the printer. Call service.
Net1: Error 1	Press Start	Serial interface option: overrun error	Verify that the handshaking protocol settings match between the printer and the host.
Net1: Error 2	Press Start	Serial interface option: parity error	Verify that the parity settings match between the printer and the host.
Net1: Error 3	Press Start	Serial interface option: framing error	Verify that the serial settings match between the printer and the host.
Net1: Error 4	Press Start	Serial interface option: flow control error	Verify that the handshaking protocol settings match between the printer and the host.
Not Ready		Printer is offline	Press Start
NVRAM Failure xx		Controller failure	Restart printer. If the problem reoccurs, call service
Out Of Memory		The job is too complex for the installed memory	Add optional memory
Panel Locked		The printer panel has been locked to prevent changes	Contact the administrator
Power Save Mode		Printer is in power save mode	None Normal Printer Operation Printer automatically returns to normal mode when data is received.

Error and Warning Messages

Troubleshooting

Error Message Line 1	Error Message Line 2	Possible Cause	Action
Printing		Job printing	None Normal Printer Operation
Processing		Data received	None Normal Printer Operation
Ready		Printer is ready and idle	None Normal Printer Operation
Resetting		Printer has received a command to reboot	None Normal Printer Operation
User FLASH Error	Select To Format	An unformatted user flash option was installed	Press Select to format the flash
Waiting		Partial data received	Wait for the remaining data to be received. Normal Printer Operation

Chapter 10: Clearing Paper Jams

When there is a paper jam, refer to the following procedures and follow the instructions.



CAUTION: Never touch areas labeled as “High Voltage.” Never touch a labeled area found on or near the heat roller. If a sheet of paper is wrapped around the heat roller, do not try to remove it by yourself to avoid injuries or burns. Switch off the machine immediately, and contact your service provider.

NOTE: Paper jams could be due to the printer installation environment and type of paper used.

The diagram below shows the printer with the two optional tray modules, duplex module, and Offset Catch Tray installed.

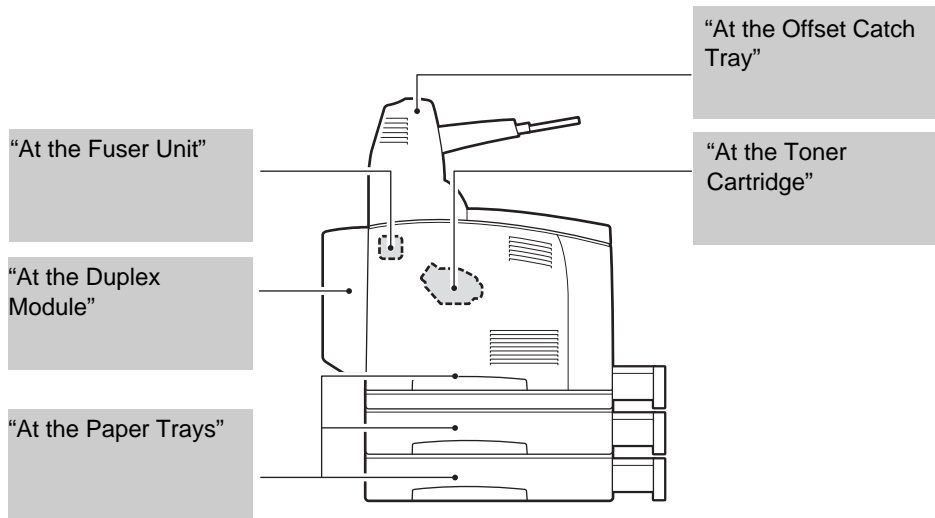

NOTE: If the jammed paper is removed without opening the top cover, you still need to open and close the top cover. Doing this will remove the error message.

In this Chapter...

- At the Paper Trays
- At the Fuser Unit
- At the Toner Cartridge
- At the Duplex Module
- At the Offset Catch Tray

At the Paper Trays

Clearing Paper Jams

At the Paper Trays

1. Pull the paper tray out of the printer.

The paper tray must be pulled out completely. If the paper tray is pulled out halfway and pushed in again, the paper may be damaged.

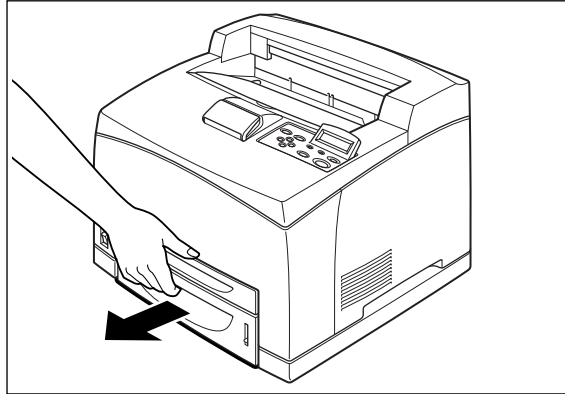

NOTE: If the paper is jammed inside the printer and behind the first level paper tray, pull out both the first and the second level paper trays.

NOTE: If the paper is jammed inside the printer and behind the second level paper tray, pull out only the second level paper tray.

2. Remove any wrinkled paper in the paper tray.

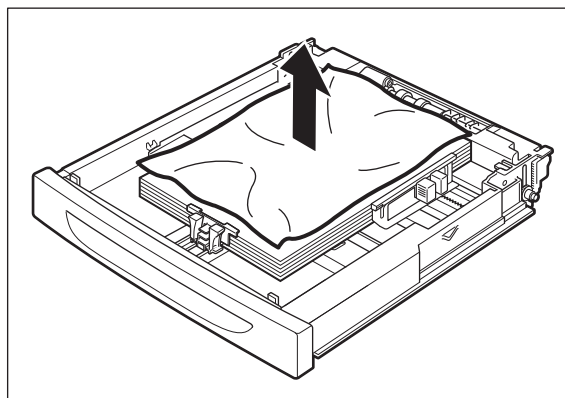

3. Remove any paper jammed inside the printer.

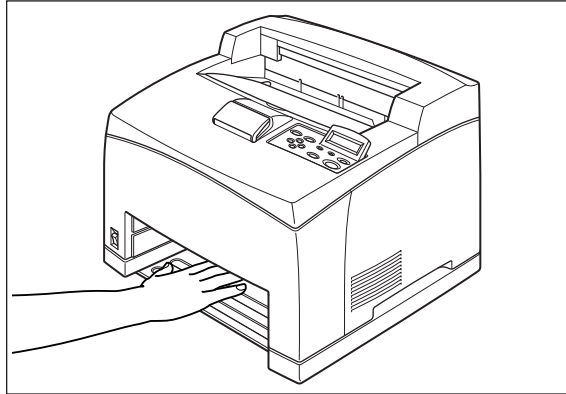

NOTE: If the printer is installed with the two optional tray modules, examine the interior of all the tray modules.

4. Push the paper tray completely into the printer.

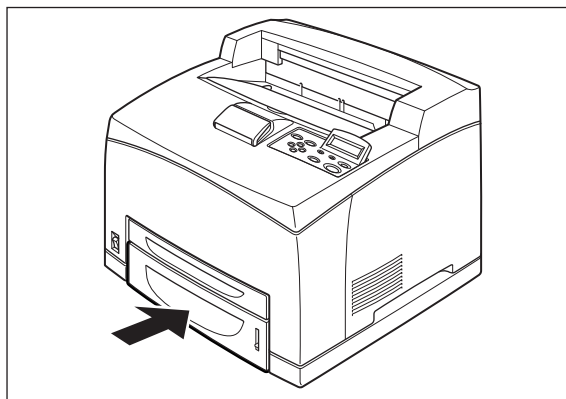

5. Open and close the top cover to clear the Jam message.

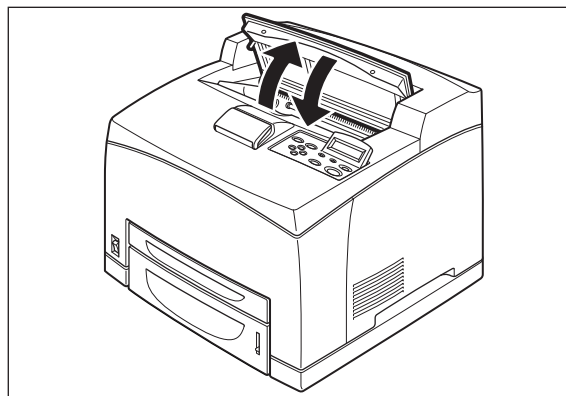

At the Fuser Unit

Clearing Paper Jams

At the Fuser Unit

1. Remove any paper from the Standard Output Tray.

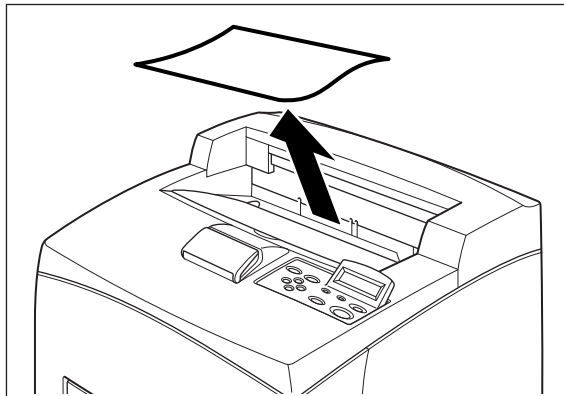

NOTE: If the duplex unit is installed, open the cover of the Duplex module first. See “At the Duplex Module” on page 10-8.

2. Lift the second lever from the top left corner of the back of the printer.

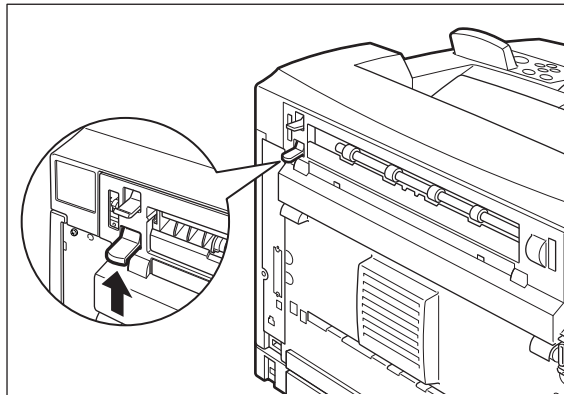

3. Open the rear cover.

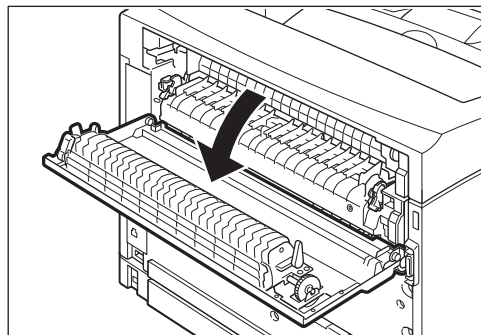

NOTE: Do not touch any parts inside the printer.

4. Open the cover of the Fuser Unit and remove any jammed paper. If paper is torn, check for any remaining torn pieces of paper.

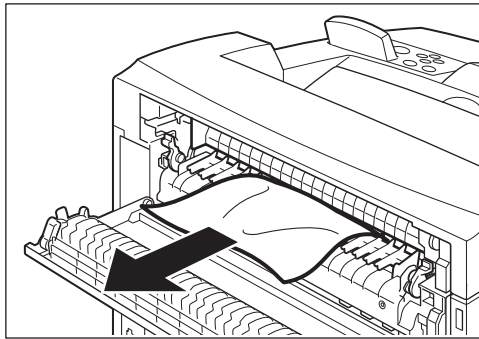

The Fuser Unit is hot. Be careful not to touch it as you can get burned.
Make sure that the levers at both ends of the Fuser Unit are returned to the positions they were in before clearing the jam.
If you let go of the cover of the Fuser Unit, it will return to its original position.

5. Close the rear cover.

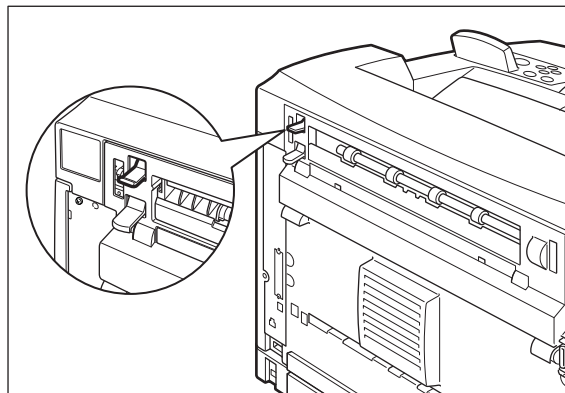
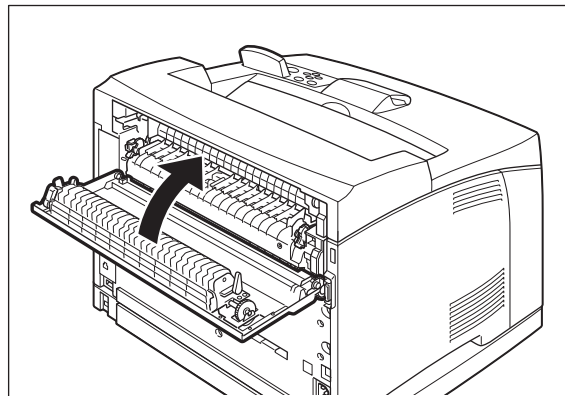

NOTE: Make sure that the levers at the rear of the printer, as shown in the diagram, are returned to the positions they were in before clearing the jam.

At the Toner Cartridge

Clearing Paper Jams

6. Open and close the top cover to clear the Jam message.

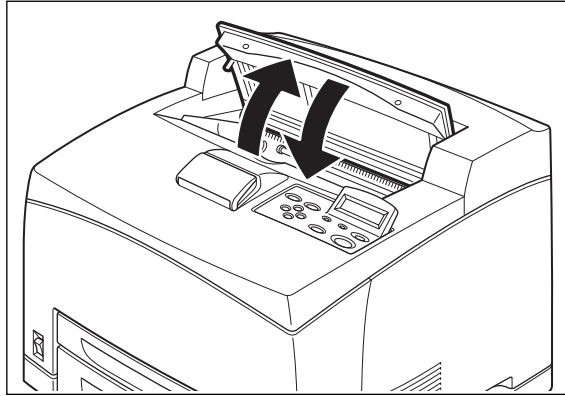

At the Toner Cartridge

1. Remove any paper in the Standard Output Tray.

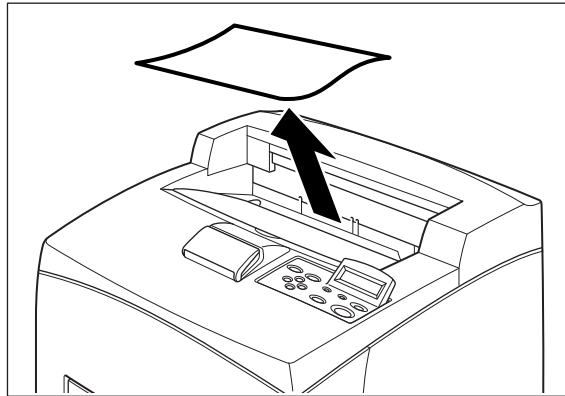

2. Open the top cover to clear the Jam message.

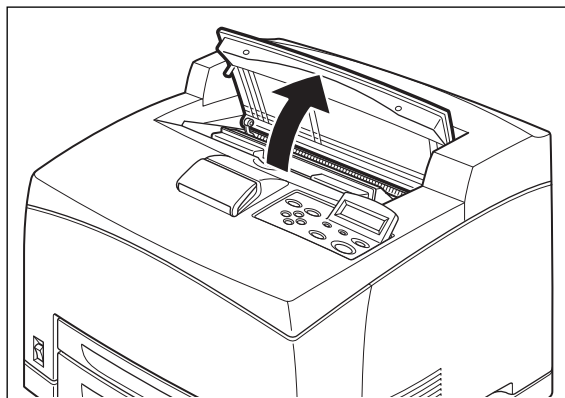

NOTE: Do not touch any parts inside the printer.

3. Hold the Toner Cartridge by the grip and pull it out slowly. Then place it on a flat surface.

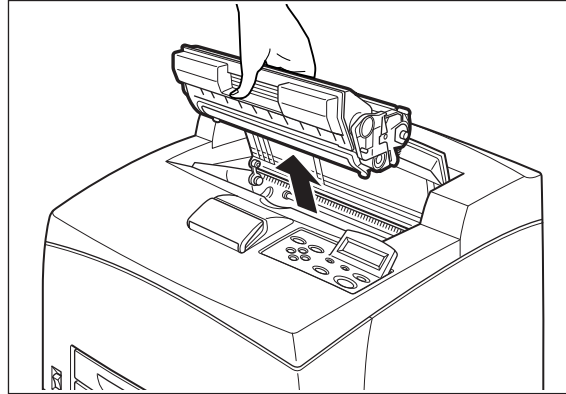

NOTE: To prevent the toner from getting the surface dirty, lay a piece of paper down to place the Toner Cartridge on.

4. Remove Tray 1.
5. Examine the interior from which the Toner Cartridge has been taken out and remove any jammed paper. By rotating the rollers as shown in the diagram, the paper will be loosened and can be removed easily. If paper is torn, check for any remaining torn pieces of paper.

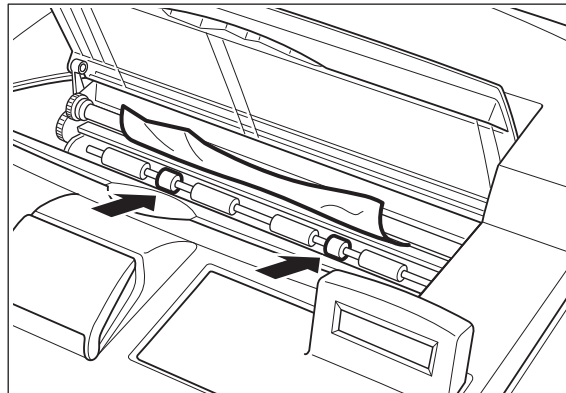

6. Hold the Toner Cartridge by the grip and insert it into the slot inside the printer.

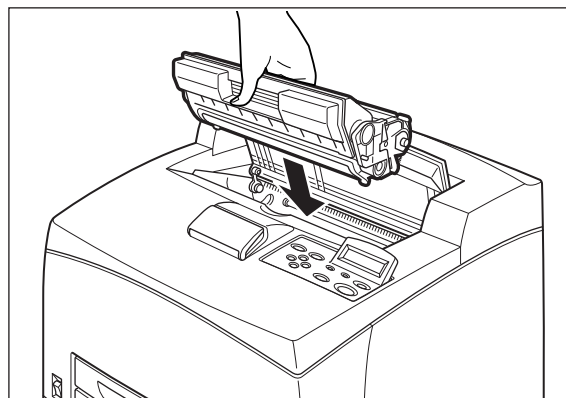

At the Duplex Module

Clearing Paper Jams

NOTE: Do not touch any parts inside the printer. Ensure that the Toner Cartridge is correctly installed.

7. Close the top cover securely.

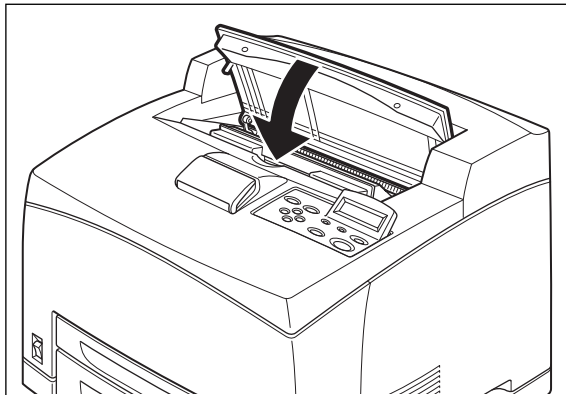

At the Duplex Module

Duplex at the paper exit

1. Examine the paper exit and remove any jammed paper. If paper is torn, check for any remaining torn pieces of paper.

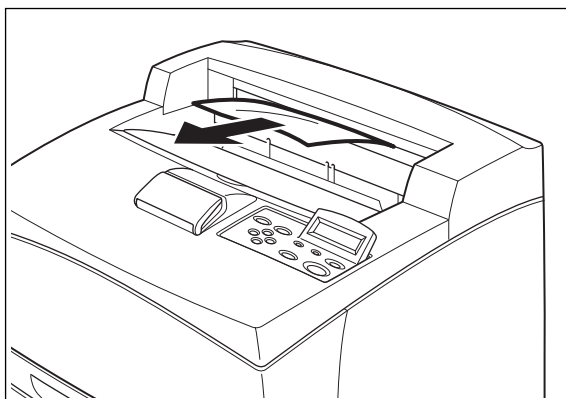

NOTE: If the paper is difficult to remove, carry out the operation in the following section, See “Duplex at the interior of the top cover” on page 10-9

2. Open and close the top cover to clear the Jam message.

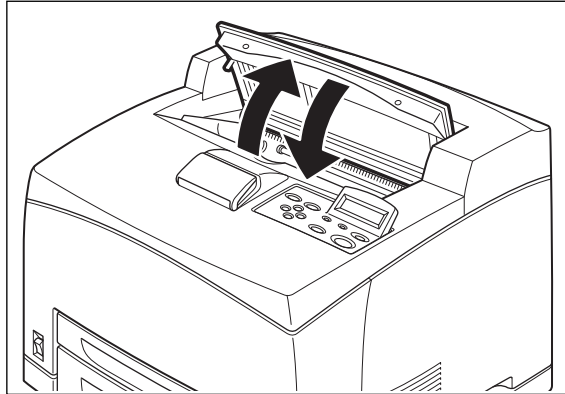

Duplex at the interior of the top cover

1. Lift the lever at the top left hand side of the duplex module to unlock it and open the top cover of the duplex module.

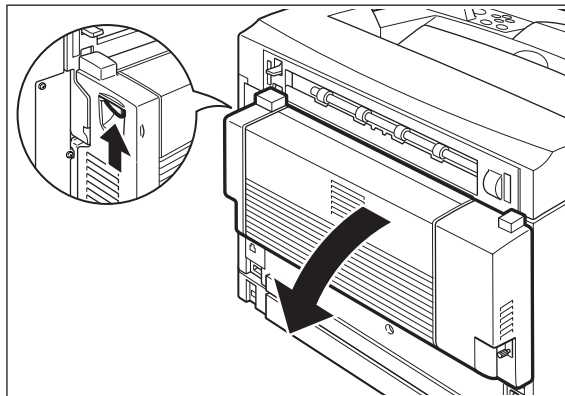

2. Examine the interior of the top cover and remove any jammed paper. If paper is torn, check for any remaining torn pieces of paper.

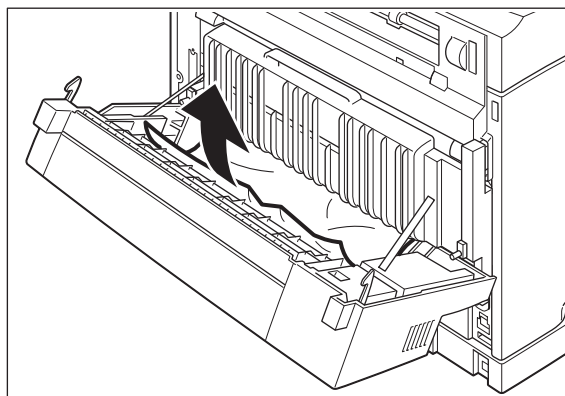

At the Offset Catch Tray

Clearing Paper Jams

3. Close the top cover of the duplex module to clear the Jam message.

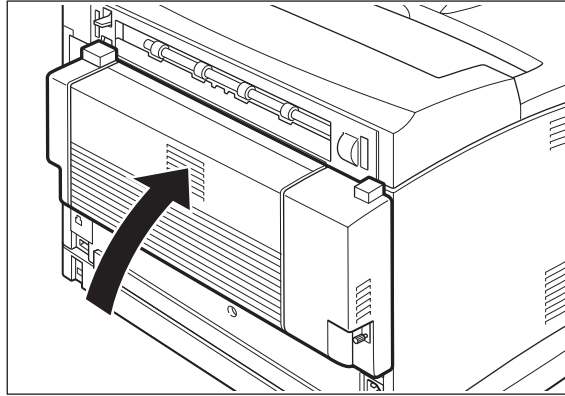

At the Offset Catch Tray

1. Open the Offset Catch Tray cover by pulling the tab at the top left of the cover.

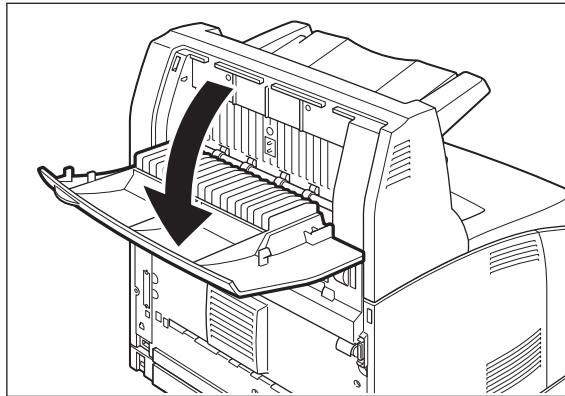

2. Remove any jammed paper.

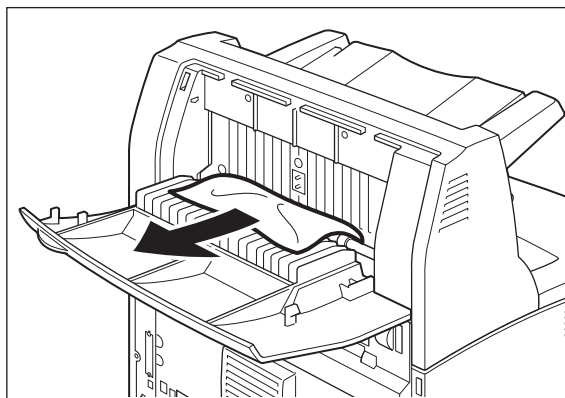

3. Close the Offset Catch Tray cover.

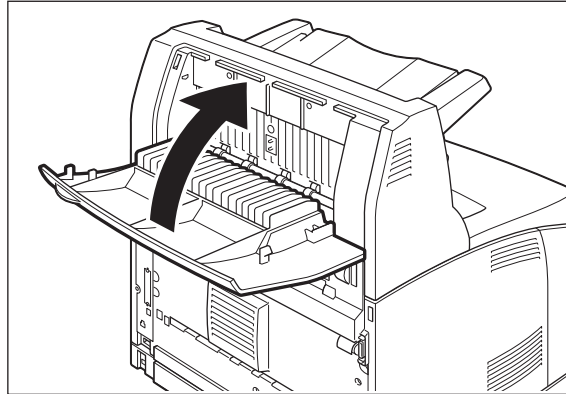

4. Lift up the second lever from the top left corner of the back of the printer to open the rear cover.

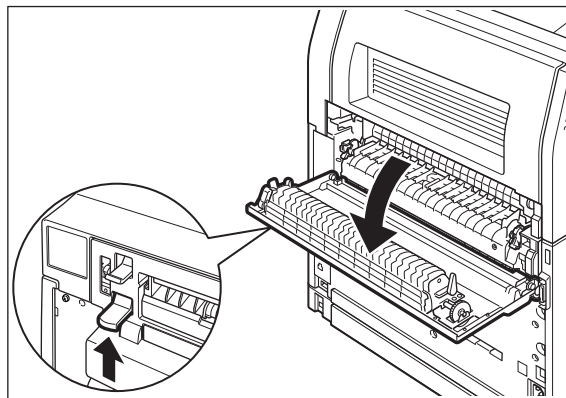

5. Remove any jammed paper. If paper is torn, check for any remaining torn pieces of paper.

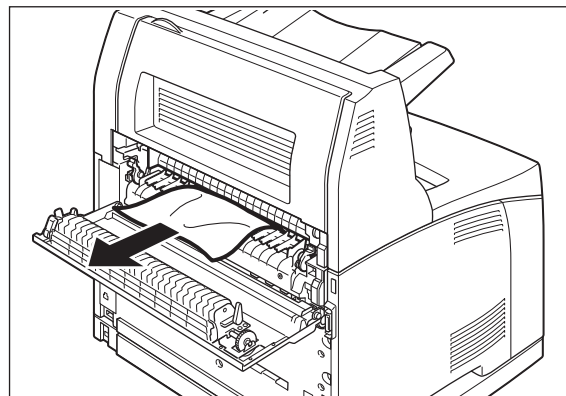

The Fuser Unit is hot. Be careful not to touch it as you can get burned. Make sure that the levers at both ends of the Fuser Unit are returned to the positions they were in before clearing the jam.

At the Offset Catch Tray

Clearing Paper Jams

6. Close the rear cover to clear the Jam message.

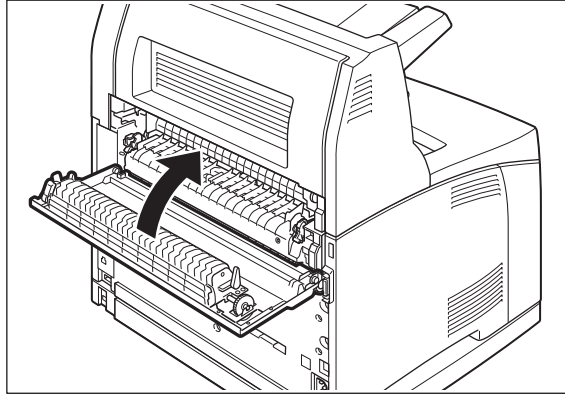

Chapter 11: Windows Utilities

A variety of Windows utilities are available with your printer. During installation, you can choose to install any of these utilities. If you have not installed a desired utility and wish to, rerun the installation and select the desired utility. These utilities allow direct communication with your printer to accomplish specific tasks.

Font and Macro Manager Utility

The Font and Macro Manager (FMM) utility supports the downloading of PCL soft fonts and macros to User Flash, Compact Flash, and Disk. PCL font formats 0, 5, 15, and 20 can be stored on the Flash or Disk device. Advanced filter control can be enabled by deselecting Default Filtering in the Tools menu.

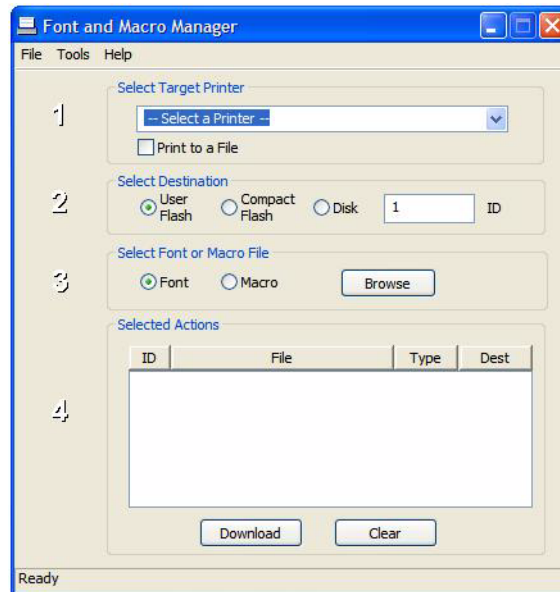

You can view these files on the Hard disk via the EWS.

In this Chapter...

- Font and Macro Manager Utility
- Status Monitor Utility
- PCL5 Tray Mapping Utility
- Printer Maintenance Utility
- Direct PDF Utility

Status Monitor Utility

Windows Utilities

Status Monitor Utility

The printer Status Monitor utility runs on the Windows XP, Win2K, or Vista system to which the printer is connected via a Parallel, USB, or network port. This utility communicates bi-directionally with the printer to obtain status information about error conditions and status. These conditions are reported using “pop-ups” on the screen.

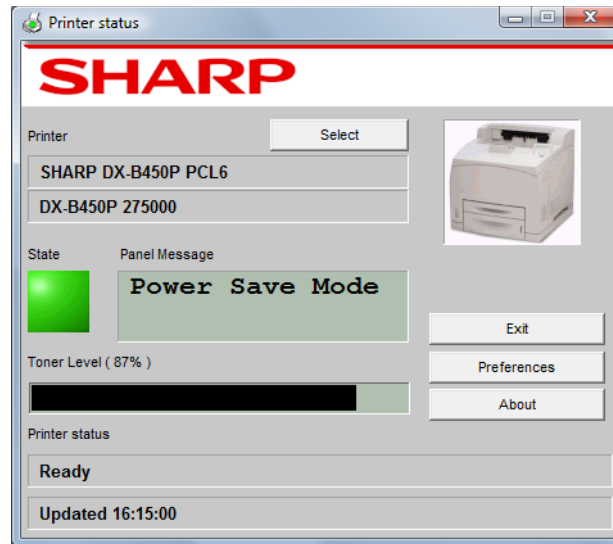

PCL5 Tray Mapping Utility

This utility allows you to reassign the PCL5 tray ID selection sequences so an existing application can be used to select the desired paper trays. The Tray Mapping Utility changes the PCL5 tray IDs to custom values. This is useful to programs that generate printer data directly without going through the Windows Printer Driver. Older MS-DOS programs are typically the programs that require tray ID remapping. Once the tray IDs are changed, the new mapping affects all users of the printer.

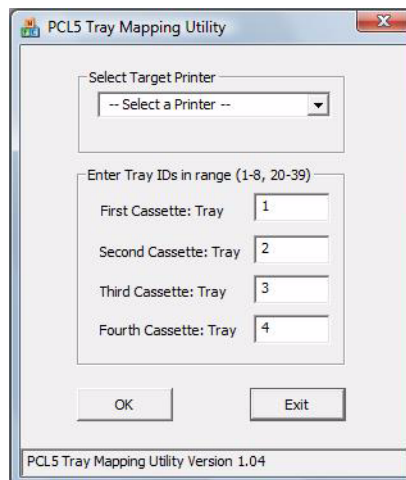

To use the program:

1. Select the target printer.

The printer must be installed on a Windows system to be a target printer.

2. Enter new tray IDs.
3. Click **OK**.

Direct PDF Utility

The printer's Direct PDF Utility allows you to send a Version 1.3 PDF file directly to the printer without the use of Adobe Acrobat on the host computer and without using the printer driver.

To start Direct PDF Print, right-click on the PDF document and select Direct PDF Print.

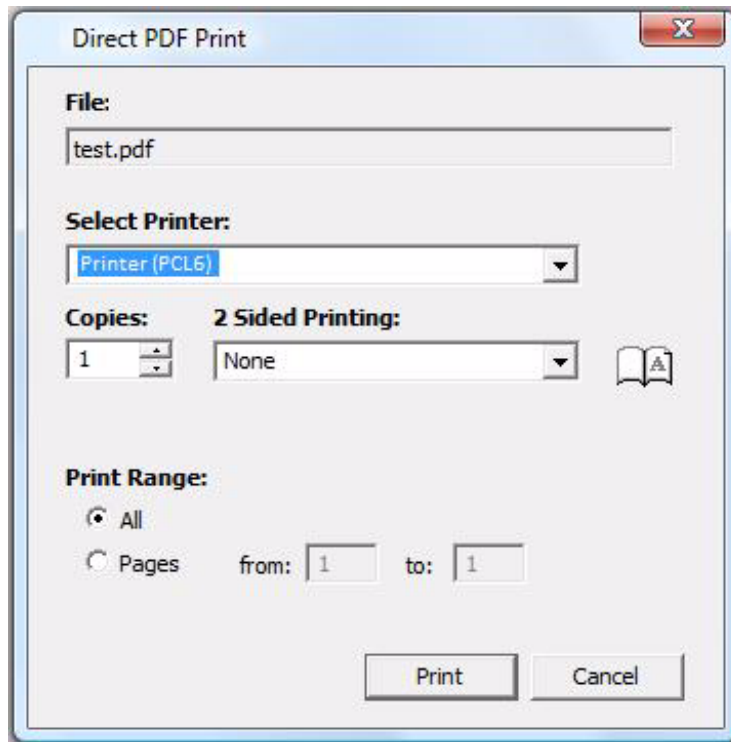

Symbols

SNMP Alerts 7-6

Numerics

2-Sided Printing 4-9

A

A4 2-5

A5 2-5

A6 2-5

About 1-1

Access panel 2-1

Accessing the Driver 4-6

Accessories 8-1

acid paper 2-11

Actions 9-8

Active 3-2

Address Ranges/Permissions 6-5

adhesive backing 2-11

Administrator Address 6-5

Adobe 2-4

Advanced tab 4-7, 4-16

alkaline paper 2-11

Application access driver 4-6

Auto Configuration 4-3

Auto Resize 3-7, 5-6, 6-4

Auto tray changing 4-14

Automatically sensed 2-5

Auto-Sense 3-7

B

B5 2-5

Binding Edge 4-11

Blank or All Black 9-2

Blank Pages 3-7, 4-15, 6-4

Blurred 9-2

Bond 2-6

Brightness 4-16

Buttons 3-2

C

C5 2-5

Cancel 3-2

<CANCEL> button 4-5

Cancel printing 4-5

Cannot print 9-6

Carbon paper 2-11

Cardstock 2-6

CF 3-17

CF Card 8-22

Clarity 9-7

Clock Adjust 6-4

Collate 4-9

Collated 5-5

Color 2-6

Color Matching 5-5

COM10 2-5

COM9 2-5

Compact Flash Card 8-22

Components 2-1

Configuration Summary 3-2, 3-4

Configuration tab 4-3

Console Security 6-5

Consumable Message 6-5

Contrast 4-16

Conventions 1-1

Copies 3-6, 4-8, 5-5, 6-4

Counter Type 3-20

Cover Open 6-5

Cover Page 5-6

Cover Sheet 4-13

Cover sheet 4-13

CR Mode 3-14, 6-4

Custom 2-5

Custom Size 2-6, 3-7, 4-13

Custom Size Unit 3-8, 6-4

D

Date & Time Settings 6-4

Date/Time Menu 3-17

Day 3-17

Default Gateway 6-5

Default Source 3-6, 6-4

Default Values 4-2

Destination 4-9

Device Status 6-3

DHCP 6-5, 7-1
Direct PDF Utility 11-4
Disk 3-17
Display 3-1
Display Area 6-2
Display Language 3-15, 6-3, 6-4
DL 2-5
DNS 6-5
DNS Settings 6-4
Driver 4-1
Driver access 4-6
Driver Configure 7-2
Drivers 2-4
Duplex 3-6, 4-9, 6-4
Duplex Bind 3-6, 6-4
Duplex Module 2-2, 8-10, 10-8
DX-B350P 1-1
DX-B450P 1-1

E

Edge to Edge 3-8, 6-4
Embedded web server 6-1
Envelope 2-6
Envelopes 2-8
Erase Cycles 6-5
Error 9-8
Error messages 9-8
Ethernet 2-2
EtherTalk 6-5
EWS 6-1
EWS IP 7-2
Executive 2-5

F

Factory Defaults 3-15, 6-4
Faded 9-2
Fault 3-2
Feed error 9-7
FF Mode 3-14, 6-4
fibrous paper 2-11
Fit to page 4-14
FLASH Menu 3-17
Flash Summary 3-17
FMM 11-1
Font and Macro Manager Utility 11-1
Font Number 3-13, 6-4

Font Source 3-13, 6-4
Font Substitution 4-17
Fonts 4-17
Format device 3-17
Front view 2-1
Full-color transparencies 2-11
full-color transparencies 2-11
Functions Menu 3-16
Fuser Count 3-20
Fuser Counter 6-4
Fuser Unit 2-3, 10-4

G

GSM 2-5

H

Hard Disk Drive 8-21
Heat sensitive paper 2-11
Hewlett Packard Web Jet Administrative Com-
patibility 7-6
Hex Print 3-16, 6-4
Hold After Print 4-21
Hold Only 4-21
Hour 3-17
Hub Link Speed/Duplex Configuration 7-3

I

I/O Port Configuration 7-3
IEEE 1284 2-2
Image Counter 3-20, 6-4
Image Options 4-16
Indicators 3-2
Info 3-2
Input tray linking 4-14
Install options in windows driver 4-3
Installing/uninstalling the duplex module 8-15
Installing/uninstalling the offset catch tray 8-15
Installing/uninstalling the tray module 8-2
Interface Menu 3-8
Internal Components 2-3
Invoice 2-5
IP Address 6-5, 7-1
IP Filtering 6-5, 7-4
IPv4 6-1
IPv6 6-1, 6-5
IPv6 Implementation 7-5

J

Jam Recovery 3-16, 6-4
Jams 10-1
Job Accounting 4-18, 6-4
Job Accounting Menu 3-5
Job Handling 4-21
Job Handling tab 4-7, 4-18
Job Library 6-3
Job Library Menu 3-5
Job Offset 3-7, 4-12, 5-6
Job Poll Interval 6-5
Job retention 4-20
Job storage 4-20
Job Timeout 3-16, 6-4

L

Labels 2-6, 2-8
Landscape 4-9
Language 3-15, 6-3
Layout 5-5
LCD display 3-1
LED indicators 3-2
Left-navigation area 6-2
Legal 2-5
Legal13 2-5
Length guide 2-12
Letter 2-5
Letter Head 2-6
LF Mode 3-14, 6-4
Lines Per Page 3-14, 6-4
Loading paper 2-11, 3-4, 4-13
Lock tabs 2-15
Login 6-3
Logout 6-3
Low power mode 2-17

M

MAC 2-4
Mac Driver 5-1
Macintosh 5-1
Main tab 4-7, 4-8
Maintenance Reqd 9-11
Manual Feed 3-6, 4-16, 6-4
Manual IP 7-2
Manually install 4-3

Margin shift 4-11
Mass Storage Error 6-5
mDNS 6-5
Media
 suggested 2-9
Media Check 4-14, 5-6
Media Type 3-7, 5-6
Media Types 2-6
Memory Expansion Module 8-20
Menu 3-2
metal fasteners 2-11
Microsoft Windows operating systems 2-4
Minute 3-17
Mode 6-5
Monarch 2-5
Month 3-17
Multiple pages 4-11
Multiple Pages to Single Sheet 4-11

N

Navigation 3-3
NDS Context 6-5
NDS Tree Name 6-5
Netware 6-5
Netware Frame 6-5
Netware Setup 3-11
Network 1 Setup 3-10
Network configuration settings 7-3
Network Names 6-4
Network Status 6-3
Network Summary 3-16
Networking 7-1
Next 3-2
No power 9-6, 9-8
No print 9-6
Noise 9-8
Notifications 7-4
NPRINTER 6-5
N-up 4-11

O

Object Identifiers 7-6
Off 2-4
Offline 6-5
Offset 4-12
Offset Catch Error 6-5

Offset Catch Tray 2-1, 5-6, 8-14, 10-10
Offset Catch Tray Rear Cover 2-2
Offset from GMT 3-17
On 2-4
Operator Panel 2-1, 3-1
Operator Panel Menus
 Defined 3-5
 Navigate 3-3
Optional Duplex Module 2-2
Optional Tray Module 2-1
Options 8-1
Orientation 1-2, 3-13, 4-9, 5-5, 6-4
Output Destination 4-9
Output Linking 3-7, 6-4
Output Tray 3-6, 6-4
Overlay Options 4-17
Overlays 4-16

P

Page Counters 3-20
Page Description Languages 2-4
Panel Lock 3-4
Paper
 suggested 2-9
 unusable 2-11
paper clips 2-11
Paper Feed 5-6
Paper Gauge 2-1
Paper Handling 5-5
Paper Jam 6-5
Paper Jams 10-1
Paper Larger Than A4/Letter Size 2-14
Paper Low/Paper Out 6-5
Paper Menu 3-6
Paper Size 2-5, 4-13, 5-5
Paper Stop 2-1, 2-3
Paper tab 4-7, 4-12
Paper Tray 10-2
Paper tray 8-10
Paper Type 3-7
Paper Types 2-6
Paper Usage 2-5
Parallel 2-2
Parallel Setup 3-8, 6-4
PCL Menu 3-13
PCL5 4-1
PCL5 Tray Mapping Utility 11-2
PCL5c 2-4
PCL5e 2-4
PCL6 2-4
PDF Utility 11-4
PDLs 2-4
Pitch 3-14, 6-4
Plain 2-6
Poor Print Quality 9-2
POP3 6-5
Port 3-8
Port On/Off 6-4
Portrait 4-9
Possible causes 9-8
Postcard 2-6
Poster Print 4-10
Poster Printing 4-10
PostScript 3 2-4, 4-1
Power 9-6
Power Receptacle 2-2
Power Reset 6-3
Power Save 2-17, 3-15, 6-4
Power saver modes 2-17
Power Switch 2-1
PPD
 Mac 5-1
PPDs 2-4
Pre-Printed 2-6
Pre-Punched 2-6
Previous 3-2
Print Area 3-14
Print Density 3-16, 6-4
Print Error Log 3-16
Print Fonts 3-16
Print PS Errors 3-13, 6-4
Print Server Name 6-5
Print Summary 3-16
Print Test 3-16
Print Usage Rep 3-16
Printer Drivers 2-4
Printer Features 5-6
Printer Properties 4-6
Printers and Faxes Menu 4-2
Printing Options 2-17
Printing Preferences 4-4

Properties 4-2
Protocols 7-1
PS Menu 3-13
PSERVER 6-5
pulp paper 2-11

Q

Quality 4-16
Quality Menu 3-16

R

RAM Buffer Clear 6-5
Rear Cover 2-2
Rear view 2-2
Reboot Printer 6-3
Recoverable Error 6-5
Remote Printer Number 6-5
Re-send Interval 6-5
Reset Printer 3-16
Resolution 3-16, 4-16, 5-6, 6-4
Restore Configuration 6-4
Retention 4-20
return 3-2
ribbons 2-11
Right width guide 2-13

S

Safety 1-2
Sample Print 4-21
Save Configuration 6-4
Saved Settings 4-7
Scale 4-14
Scheduler 5-6
Second 3-17
Select 3-2
Send File 6-3
Sensed 2-5
Separator Page 3-7, 6-4
Serial RS-232 2-2
Serial Setup 3-9, 6-4
Server 2003 2-4
Server 2008 2-4
Service Call Required 6-5
Sheet Counter 3-20
Skip Blank Pages 4-15
SMTP 6-5

SMTP Settings 6-4
SNMP 6-5, 7-5
Source 4-12
special coating 2-11
Special Media 4-12
Specify Time Zone 6-4
Stained 9-2
Standard Output Tray 2-1
Start 3-2
Start/Stop 3-2
Status 3-2, 6-3
Status Information 3-18
Status Monitor Utility 11-2
Storage
 job 4-20
Stored jobs 4-20
Subnet Mask 6-5
Symbol Set 3-14, 6-4
System Menu 3-15

T

tape 2-11
TCP/IP 6-5
Test Page 4-4
Text to Black 4-16
TextEdit 5-5
Thick 1 2-6
Thick 2 2-6
Thick 3 2-7
Thin 2-7
Toner Cartridge 2-1, 2-3, 2-15, 10-6
Toner Low 3-15, 6-4, 9-8
Toner Low/Toner Out 6-5
Toner Page Count 3-20
Toner Page Count 6-4
Toner Save 4-16
Toner Saver 3-16, 5-6, 6-4
too thick 2-11
too thin 2-11
Top Cover 2-3
Transfer Roll Cartridge 2-3
Transparencies 2-7
Transparency 2-6
Trap/Email Alerts 6-5
Traps 7-6
Tray 1 2-1

Tray 2 2-1, 8-10
Tray 3 2-1
Tray 4 2-1
Tray Controls 6-4
Tray Linking 3-7, 6-4
Tray Module 2-1, 8-2
Tray Settings 4-12
Treated colored paper 2-11
Troubleshooting 9-1
TrueType fonts 4-17
Turn off 2-4
Turn on 2-4
Two-sided 5-5

U

Unusable paper 2-11
Usage Count 3-20, 6-4
Usage Report 6-5
USB 2-2
USB Setup 3-12, 6-4
User Flash 6-5
Utilities 11-1

V

view

front 2-1
internal 2-3
rear 2-2
Vista 32/64 2-4

W

Wait Timeout 3-15, 6-4
Warning messages 9-8
Watermark 4-21
Watermark tab 4-7, 4-21
Windows Driver 4-1
Windows Utilities 11-1
WINS 6-5
WINS Settings 6-4
Wrinkled 9-2

X

XP 2-4

Y

Year 3-17

Z

Zone Name 6-5
Zoom 4-14

SHARP®

SHARP ELECTRONICS CORPORATION

1 Sharp Plaza, Mahwah, New Jersey 07495-1163.

www.sharpusa.com

SHARP ELECTRONICS OF CANADA LTD.

335 Britannia Road East, Mississauga, Ontario, L4Z 1W9

SHARP CORPORATION

This manual has been printed using a vegetable-based soy oil ink to help protect the environment.

Free Manuals Download Website

<http://myh66.com>

<http://usermanuals.us>

<http://www.somanuals.com>

<http://www.4manuals.cc>

<http://www.manual-lib.com>

<http://www.404manual.com>

<http://www.luxmanual.com>

<http://aubethermostatmanual.com>

Golf course search by state

<http://golfingnear.com>

Email search by domain

<http://emailbydomain.com>

Auto manuals search

<http://auto.somanuals.com>

TV manuals search

<http://tv.somanuals.com>