

# Audiobeam

Instructions for use

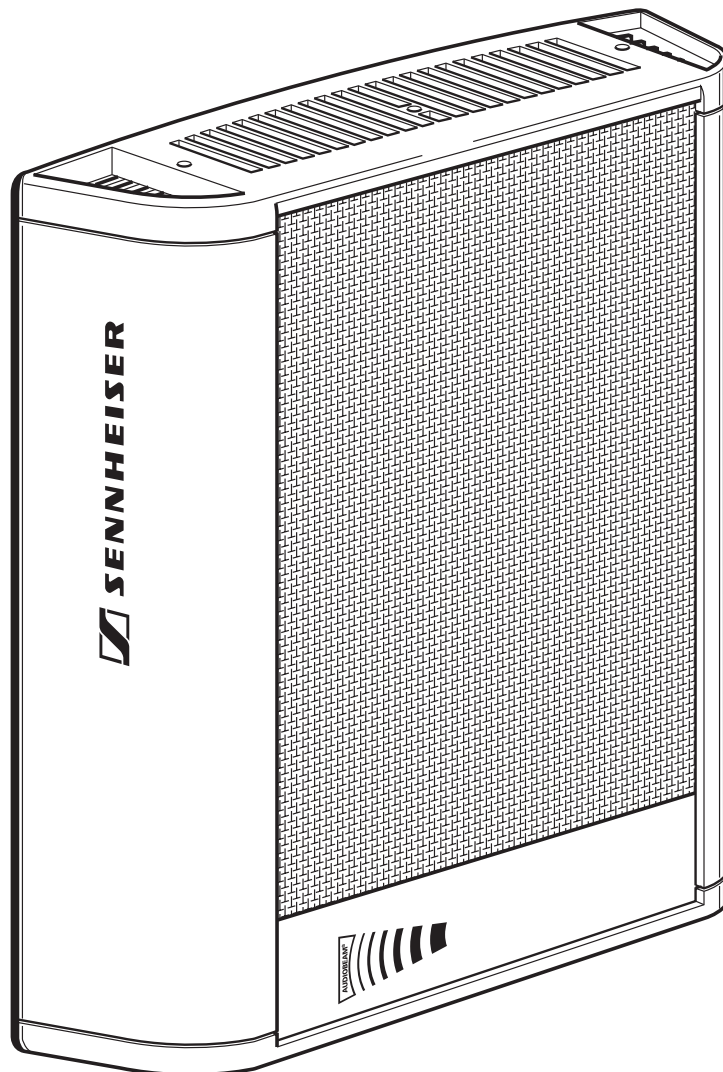



# Contents

<b>Safety instructions</b> .....	2
Warning – High Voltage – Risk of Death! .....	2
Risk of fire! .....	2
Attention! .....	2
Is there a danger of hearing damage? .....	2
<b>How Audiobeam works</b> .....	2
<b>Connections and operating controls</b> .....	3
<b>Mounting Audiobeam</b> .....	4
Correct mounting conditions .....	4
Mounting Audiobeam in a fixed position .....	4
Mounting Audiobeam movably or rotatably .....	4
Distance sensor .....	4
<b>Putting Audiobeam into operation</b> .....	4
<b>Troubleshooting</b> .....	5
<b>Accessories</b> .....	5
<b>Specifications</b> .....	6
<b>Manufacturer declarations</b> .....	7
Warranty regulations .....	7
CE Declaration of Conformity.....	7
WEEE Declaration .....	7

Thank you for choosing Sennheiser!

We have designed this product to give you reliable operation over many years. Over half a century of accumulated expertise in the design and manufacture of high-quality electro-acoustic equipment have made Sennheiser a world-leading company in this field.

Please take a few moments to read these instructions carefully, as we want you to enjoy your new Sennheiser products quickly and to the fullest.

# Safety instructions

## Warning – High Voltage – Risk of Death!



Opening the Audiobeam while it is connected to the mains is likely to result in a life-threatening electric shock!

There are no user serviceable parts inside – if the Audiobeam should become defective, any repairs must be carried out by an official Sennheiser Service Partner. If the unit is opened in breach of this instruction, the warranty becomes null and void.

## Risk of fire!



Audiobeam generates heat! Make sure that the air vents of the unit are not covered or blocked! Keep Audiobeam away from heat sources and never expose Audiobeam to direct sunlight! Maintain a minimum distance of 1 meter between Audiobeam and combustible materials.

## Attention!



If liquids or small parts which conduct electricity find their way into the interior or to the connecting sockets of Audiobeam, this can cause a short circuit! Use Audiobeam in dry rooms only and keep liquids and small parts which conduct electricity away from the unit and its connecting sockets. For cleaning Audiobeam, only use a dry or slightly damp cloth. Never use any solvents or cleansing agents.

## Is there a danger of hearing damage?

A new study tested the Audiobeam for possible damage to hearing due to the ultrasound it emits and certified its harmlessness. In this study, Prof. Dr.-Ing. Joachim Herbertz, the President of the first International Ultrasonics Congress, came to the following conclusion:

*“The ultrasound emitted by the Sennheiser Audiobeam is safe at a minimum distance of 20 cm from the protective grid”.*

The limit values of the European and international standards and guidelines IEC 71672-1, IEC 61012, GEFAU N 01 and 2003/10/EG are complied with.

# How Audiobeam works

Audiobeam is an acoustic spotlight. This means:

- Audiobeam is able to focus sound – either directly or via reflections on a surface. This allows e.g. information in museums and at exhibitions to be radiated directly from the exhibits – only visitors standing directly in front of an exhibit are addressed.
- Audiobeam limits sound reproduction to precisely defined areas – adjacent areas are kept sound-free. This helps to create a calmer overall atmosphere in rooms. Several Audiobeams can be installed in one room without affecting each other.
- Astonishing audio effects amaze visitors as Audiobeam allows the sound to come from unusual directions.

Audiobeam uses state-of-the-art ultrasonic sound transmission technology:

Audiobeam works with ultrasound, modulating the audible sound onto an ultrasonic carrier frequency. Due to the nonlinearity of air, the desired audio signal is produced by the self-demodulation effect of the ultrasound wave. At an angle of 30°, a slim sound beam is created that can be heard over long distances.

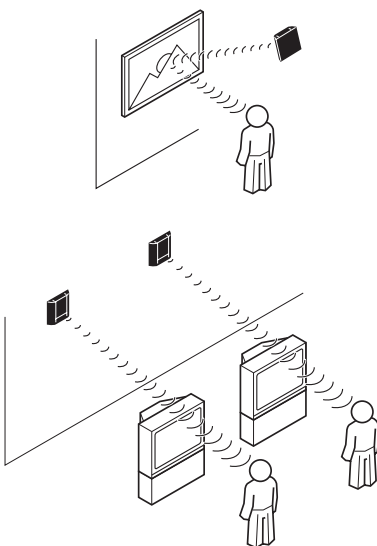

# Connections and operating controls

## Delivery includes

- Audiobeam
- 3 mains cables with connectors
- $\frac{5}{8}$ " thread with adapter to  $\frac{3}{8}$ " thread
- Instruction for use
- Warranty Certificate

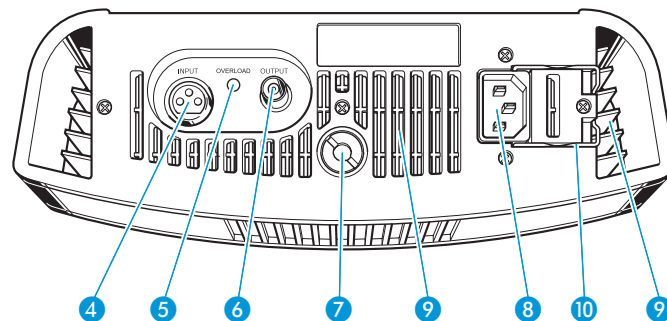
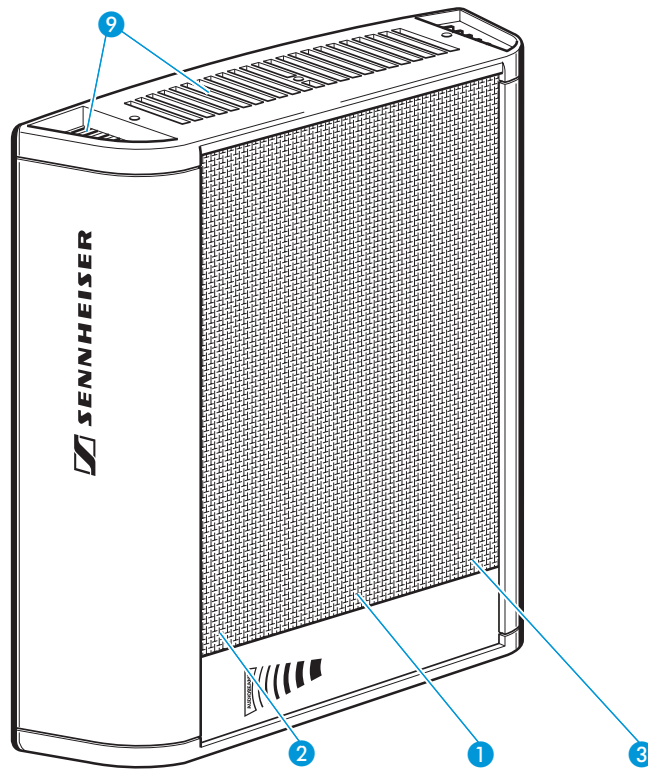

- 1 LED operation indicator: green: Audiobeam is operational (standby)  
red: Audiobeam is not operational
- 2 Sensitivity selector switch (+6 dBm, -14 dBm)
- 3 On/off switch for distance sensor is set to "ON"  
(please observe "Distance sensor" on page 4 and following!)
- 4 XLR-3 socket for audio input **INPUT**
- 5 **OVERLOAD** LED
- 6 BNC socket for carrier signal output **OUTPUT**
- 7  $\frac{5}{8}$ " thread with adapter to  $\frac{3}{8}$ " thread
- 8 IEC mains socket
- 9 Air vents
- 10 Steel clamp for securing the mains cable

# Mounting Audiobeam

## Correct mounting conditions

- ▶ When mounting Audiobeam, make sure that:
  - the ultrasonic sound wave can travel undisturbed for at least 1 m before it strikes the first surface.
  - a minimum distance of 10 cm is maintained between Audiobeam and adjacent objects so that any heat generated can dissipate. Make sure that the air vents at the top and rear of the unit are not covered or blocked!
  - a minimum distance of 1 meter is maintained between Audiobeam and combustible materials.
  - Audiobeam is kept away from heat sources such as central heating radiators, spot lights and lamps. Never expose Audiobeam to direct sunlight.
  - Audiobeam never gets wet.

## Mounting Audiobeam in a fixed position

To ensure that Audiobeam is always orientated towards the correct area of interest, you should mount Audiobeam in a fixed position. Use a mounting plate for wall or ceiling mounting. For mobile installations, use a table or floor stand (see "Accessories" on page 5).

- ▶ Screw the mounting plate or the table or floor stand to the  $\frac{5}{8}$ " thread. Use the thread adapter 7 if necessary.
- ▶ By using a gooseneck or swivel joint (see "Accessories" on page 5), directly orientate Audiobeam towards the correct area of interest or the reflection area.

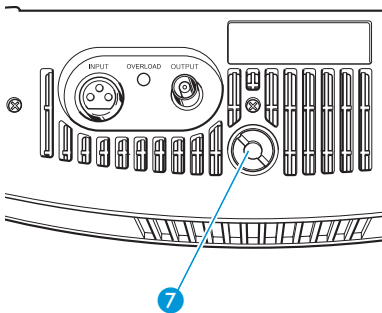

## Mounting Audiobeam movably or rotatably

- ▶ Screw Audiobeam onto a drive mechanism or a rotating mechanism using the  $\frac{5}{8}$ " thread. Use the thread adapter 7 if necessary.

## Distance sensor

For reasons of test engineering, a distance sensor 1 with a switch 3 is located on the bottom right of the emitter surface.

If the distance sensor is "on", the Audiobeam turns off whenever persons or objects are situated at a distance of less than four meters in the emitting direction of the Audiobeam.

For this reason, the distance sensor is factory-preset to "off" and should as a rule stay like this during operation in order to prevent automatic turn-off (for further information, please refer to the service instructions).

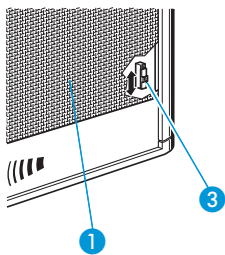

# Putting Audiobeam into operation

- ▶ Ensure that Audiobeam is **not** connected to the mains !
- ▶ Use the sensitivity selector switch 2 to adapt Audiobeam's input sensitivity to the audio source:
  - Audio sources with a high output power (e.g. mixing console, CD or DVD player): upper position (+6 dBm).
  - Audio sources with a low output power (e.g. portable mini disk player): lower position (-14 dBm).

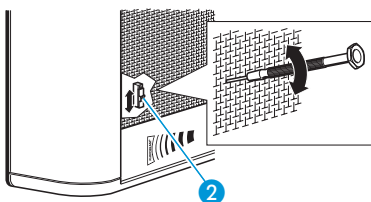

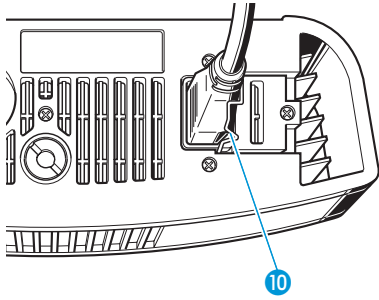

- ▶ Use an XLR-3 cable to connect the audio source (e.g. CD or DVD player, mixing console, receiver of a wireless microphone) to the audio input **INPUT 4**. Audiobeam automatically emits ultrasound as soon as an audio signal (see "Specifications" on page 6) is present at the audio input **INPUT 4**.
- ▶ Use the mains cable **8** to connect Audiobeam to the mains. Secure the mains cable with the steel clamp **10**.
- ▶ The LED operation indicator **1** lights up green, indicating that Audiobeam is ready for operation (standby).

**Note:** If you do not use the unit for a period, disconnect the mains connector from the wall socket. This helps to increase the service life of Audiobeam and save energy.

## Troubleshooting

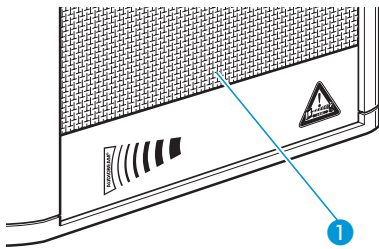

If the LED operation indicator **1** lights up red, one of the following problems may have occurred:

### On/off switch for distance sensor is activated

- ▶ Someone has entered the security area of four meters in front of or around the Audiobeam and the motion sensor has triggered. After the person has left this area, Audiobeam automatically turns on again after 30 seconds.
- ▶ Solution: Set the on/off switch for the distance sensor **3** to "off".

### Audiobeam is defective

- ▶ Please contact your Sennheiser distributor or the Sennheiser Service department (for address, see last page).

## Accessories

The following accessories are available from your Sennheiser distributor:

- GZP 10** Mounting plate for wall and ceiling mounting
- GZG 1029** Swivel joint for attachment to stands or the GZP 10 mounting plate, includes 1/4" interchangeable thread
- MZT 14** Mounting bolt for mounting goosenecks and swivel joints with 3/8" thread to table tops
- MZT 100** Stable, metal table stand with 3/8" thread
- MZT 1019** Mounting bar for two units with 3/8" internal thread
- SEMS 3134** Floor stand with 3/8" thread

# Specifications

Modulation:	wideband AM
Carrier frequency:	40 kHz
Peak limiter:	limiter amplifier
Audio channels:	1
Audio input:	XLR-3F socket, balanced, DC-isolated
Input level for max. peak SPL:	+6 dBm (1.55 V) = upper switch position -14 dBm (150 mV) = lower switch position
Switching threshold:	-46 dBm (4 mV) = upper switch position -66 dBm (0.4 mV) = lower switch position
Impedance:	600 $\Omega$
Sound pressure level:	75 dB $\pm$ 5 dB (at a distance of 4 m)
Output:	1 x BNC, 50 $\Omega$ shortcircuit-proof
Amplifier power:	approx. 90 W
Power supply:	switchable power supply 110 - 240 V, 50 - 60 Hz max. 100 W
Dimensions:	264 x 82 x 320 mm
Weight:	approx. 4 kg
XLR-3 pin assignment:	

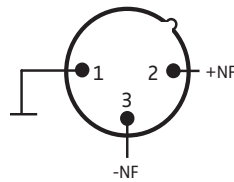



# Manufacturer declarations

## Warranty regulations

The guarantee period for this Sennheiser product is 24 months from the date of purchase. Excluded are accessory items and disposable batteries that are delivered with the product; due to their characteristics these products have a shorter service life that is principally dependent on the individual frequency of use.

The guarantee period starts from the date of original purchase. For this reason, we recommend that the sales receipt be retained as proof of purchase. Without this proof (which is checked by the responsible Sennheiser service partner) you will not be reimbursed for any repairs that are carried out.

Depending on our choice, guarantee service comprises, free of charge, the removal of material and manufacturing defects through repair or replacement of either individual parts or the entire device. Inappropriate usage (e.g. operating faults, mechanical damages, incorrect operating voltage), wear and tear, force majeure and defects which were known at the time of purchase are excluded from guarantee claims. The guarantee is void if the product is manipulated by non-authorised persons or repair stations.

In the case of a claim under the terms of this guarantee, send the device, including accessories and sales receipt, to the responsible service partner. To minimise the risk of transport damage, we recommend that the original packaging is used. Your legal rights against the seller, resulting from the contract of sale, are not affected by this guarantee.

The guarantee can be claimed in all countries outside the U.S. provided that no national law limits our terms of guarantee.

## CE Declaration of Conformity

**CE 0682** 

This equipment is in compliance with the essential requirements and other relevant provisions of Directives 1999/5/EC, 89/336/EC or 73/23/EC. The declaration is available on the internet site at [www.sennheiser.com](http://www.sennheiser.com).

Before putting the device into operation, please observe the respective country-specific regulations!

## WEEE Declaration



Your Sennheiser product was developed and manufactured with high quality materials and components which can be recycled and/or reused. This symbol indicates that electrical and electronic equipment must be disposed of separately from normal waste at the end of its operational lifetime.

Please dispose of this product by bringing it to your local collection point or recycling centre for such equipment. This will help to protect the environment in which we all live.



Sennheiser electronic GmbH & Co. KG  
30900 Wedemark, Germany  
Phone +49 (5130) 600 0  
Fax +49 (5130) 600 300  
[www.sennheiser.com](http://www.sennheiser.com)

Printed in Germany

Publ. 05/06

089056/A1

## Free Manuals Download Website

<http://myh66.com>

<http://usermanuals.us>

<http://www.somanuals.com>

<http://www.4manuals.cc>

<http://www.manual-lib.com>

<http://www.404manual.com>

<http://www.luxmanual.com>

<http://aubethermostatmanual.com>

Golf course search by state

<http://golfingnear.com>

Email search by domain

<http://emailbydomain.com>

Auto manuals search

<http://auto.somanuals.com>

TV manuals search

<http://tv.somanuals.com>