

# Sears

# owners manual

## CRAFTSMAN 10-INCH RADIAL ARM SAW

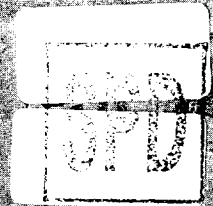

MODEL No.  
113.29450

**CAUTION:**  
Read Safety  
Rules and  
Instructions  
Carefully

- Assembly
- Operating
- Repair Parts

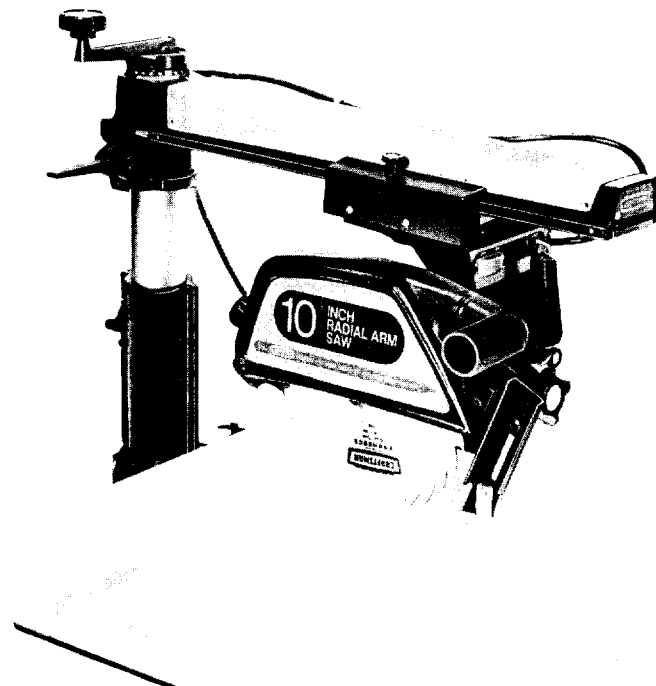

MAN 85220

# SAFETY RULES FOR POWER TOOLS

## 1. KNOW YOUR POWER TOOL

Read the owner's manual carefully. Learn its application and limitations as well as the specific potential hazards peculiar to this tool.

## 2. GROUND ALL TOOLS

If tool is equipped with three-prong plug, it should be plugged into a three-hole receptacle. If adapter is used to accommodate two-prong receptacle, the adapter wire must be attached to a *known ground*. Never remove third prong.

## 3. KEEP GUARDS IN PLACE

and in working order.

## 4. REMOVE ADJUSTING KEYS AND WRENCHES

Form habit of checking to see that keys and adjusting wrenches are removed from tool before turning on tool.

## 5. KEEP WORK AREA CLEAN

Cluttered areas and benches invite accidents.

## 6. AVOID DANGEROUS ENVIRONMENT

Don't use power tools in damp or wet locations. Keep work area well illuminated.

## 7. KEEP CHILDREN AWAY

All visitors should be kept a safe distance from work area.

## 8. MAKE WORKSHOP KID PROOF

— with padlocks, master switches, or by removing starter keys.

## 9. DON'T FORCE TOOL

It will do the job better and be safer at the rate for which it was designed.

## 10. USE RIGHT TOOL

Don't force tool or attachment to do a job it was not designed for.

## 11. WEAR PROPER APPAREL

No loose clothing or jewelry to get caught in moving parts.

## 12. USE SAFETY GLASSES

Also use face or dust mask if cutting operation is dusty.

## 13. SECURE WORK

Use clamps or a vise to hold work when practical. It's safer than using your hand, frees both hands to operate tool.

## 14. DON'T OVERREACH

Keep your proper footing and balance at all times.

## 15. MAINTAIN TOOLS IN TOP CONDITION

Keep tools sharp and clean for best and safest performance. Follow instructions for lubricating and changing accessories.

## 16. DISCONNECT TOOLS

before servicing and when changing accessories such as blades, bits, cutters.

## 17. AVOID ACCIDENTAL STARTING

Make sure switch is "OFF" before plugging in cord.

## 18. USE RECOMMENDED ACCESSORIES

Consult the owner's manual. Use of improper accessories may be hazardous.



The operation of any power tool can result in foreign objects being thrown into the eyes, which can result in severe eye damage. Always wear safety glasses or eye shields before commencing power tool operation. We recommend **Wide Vision Safety Mask** for use over spectacles, or standard safety glasses . . . available at Sears retail or catalog stores.



### THIS SAFETY SEAL OF THE POWER TOOL INSTITUTE ASSURES YOU . . .

1. That the manufacturer's power tools, including the particular tool associated with the Seal, are produced in accordance with applicable Standards For Safety of Underwriters' Laboratories and American National Standards (ANSI).
2. That compliance with applicable safety standards is assured by independent inspection and testing conducted by Underwriters' Laboratories (UL).
3. That every motorized tool is inspected under power.
4. That every tool has with it adequate instructions and a list of safety rules for the protection of the user.
5. That the tool manufacturer is a member of the Power Tool Institute and is a sponsor of the Institute's Consumer Safety Education Program.

# ASSEMBLING AND ADJUSTING YOUR SAW

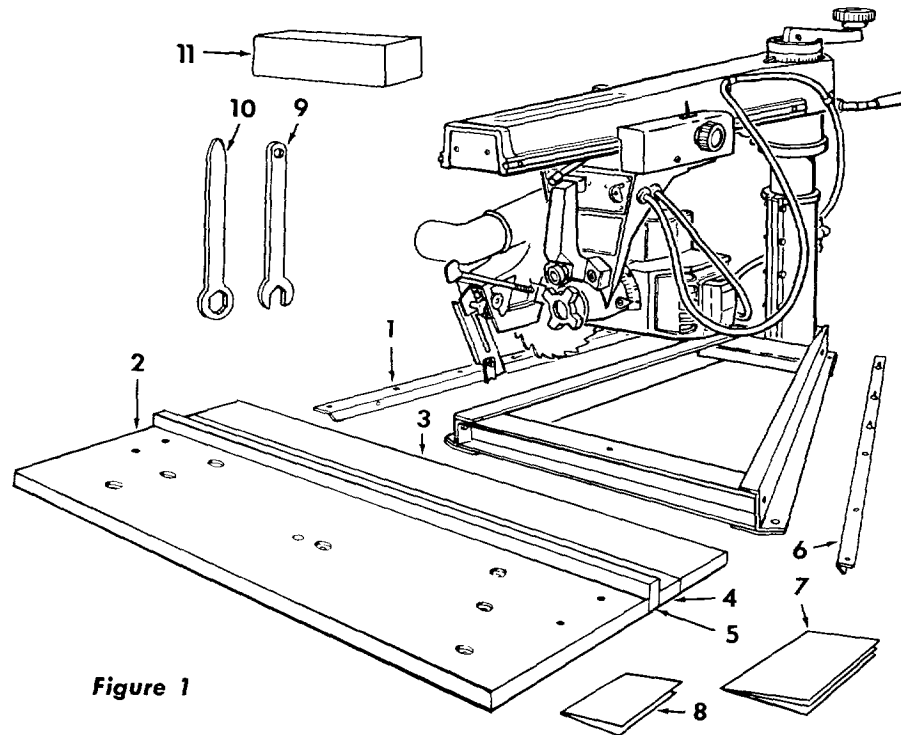

Figure 1

## UNPACKING AND CHECKING CONTENTS

This Craftsman 10-inch Radial Saw is shipped complete in one carton. In order to prevent damage during shipment and facilitate packaging, certain items are removed at the factory and must be assembled when received by the purchaser. These "loose" items are listed below and should be accounted for before discarding any packing materials.

Key No. (Fig. 1)	Item Name	Qty.
1	Table Support, Left-hand	1
2	Table, Front	1
3	Table, Rear	1
4	Table, Spacer	1
5	Fence, Rip	1
6	Table Support, Right-hand	1
7	Owner's Manual	1
8	Unpacking Instructions	1
9	Shaft Wrench	1
10	Arbor Wrench	1
11	Pack Assm., Loose Parts (containing the following):	
	Wrench, Hex-L, 1/8"	1
	Wrench, Hex-L, 3/16"	1
	Wrench, Hex-L, 1/4"	1
	Wrench, Hex-L, 5/16"	1
	Washer, Plain, 11/32 x 7/8 x 1/16"	4
	Lockwasher, 5/16 x .125 x .078"	4
	Screw, Hex. Hd. 5/16-18 x 3/4"	4
	Screw, M. Pan. Sl., 1/4-20 x 1"	6
	Washer, Plain, 17/64 x 5/8 x 1/32"	7
	Lockwasher, Steel, 1/4 x .109 x .062"	6
	Nut, Hex., 1/4-20 x 7/16 x 3/16"	6
	Nut, Tee	1

Key No. (Fig. 1)	Item Name	Qty.
	Screw, M. Pan. Sl., 1/4-20 x 1-1/4"	1
	Screw, Sl. Cup Pt., Set, 1/4-20 x 1/2"	1
	Screw, Type A, Pan Hd., Sl., No. 10 x 5/8"	4
	Screw, Type 23, Pan Hd., Sl., No. 6-32 x 5/16"	2
	Nut, U-Clip (1/4-20)	1
	Clamp, Table	2
	Switch Key	2
	Shoe, Carriage Lock	1
	Knob, Carriage Lock	1
	Indicator, Rip	1
	Nut, Twin	1
	Bracket, Rear Table Support	2

## POWER SUPPLY AND MOTOR DATA

### MOTOR SPECIFICATIONS

The a-c motor used in this Craftsman Radial Saw is of the capacitor start, non-reversible type with the following specifications:

Voltage	120
Amperes	12.5
Hertz	60
Phase	Single
RPM	3450
Rotation (viewing saw blade end)	Clockwise

**CAUTION:** This motor is wired for 120 volt operation. Connect to 15 ampere branch circuit and use a 15 ampere time-delay fuse.

## MOTOR SAFETY PROTECTION

The saw motor is equipped with a manual-reset thermal overload protector, designed to open the power line circuit when the motor temperature exceeds a safe value.

1. If the protector opens the line and stops the saw motor, press the saw switch to the "OFF" position immediately and allow the motor to cool.
2. After cooling to a safe operating temperature, the overload protector can be closed manually by pushing in the red button on the motor cover and nameplate. If the red button will not snap into place immediately, the motor is still too hot and must be allowed to cool for a while longer. (An audible click will indicate protector is closed.)
3. As soon as the red button will snap into running position, the saw may be started and operated normally by pressing the saw switch to the "ON" position.
4. Frequent opening of fuses or circuit breakers may result if motor is overloaded, or if the motor circuit is fused with a fuse other than those recommended. Do not use a fuse of greater capacity without consulting the power company.
5. Although the motor is designed for operation on the voltage and frequency specified on motor nameplate, normal loads will be handled safely on voltages not more than 10% above or below the nameplate voltage. Heavy loads, however, require that voltage at motor terminals be not less than the voltage specified on nameplate.
6. Most motor troubles may be traced to loose or incorrect connections, overloading, reduced input voltage (which results when small size wires are used in the supply circuit) or when the supply circuit is extremely long. Always check connections, load and supply circuit when the motor fails to perform satisfactorily. Check wire sizes and lengths with the table in the next paragraph.

**IMPORTANT:** The following wire sizes are recommended for connecting the motor to power source for trouble-free operation.

Length of Conductor	Wire Size Required (American Wire Gauge No.)
50 feet or less	No. 12
100 feet or less	No. 10
100 feet to 150 feet	No. 8
150 feet to 200 feet	No. 6
200 feet to 400 feet	No. 4

For circuits of greater length the wire size must be increased proportionally.

## MOUNTING THE SAW ON A WORK BENCH

The saw should be placed on a suitable sturdy work bench, or Craftsman Power Tool Bench. The base of the saw must be mounted flush to a flat surface on the work bench to prevent distortion of the saw base. The nuts, screws, and washers which attach the wooden shipping skids to the saw base may be used to secure the saw base to the work bench, or tool bench.

## ALIGNMENT INSTRUCTIONS

**NOTE:** The seven basic "steps" that follow are essential in order to insure correct saw table alignment.

**WARNING:** Make sure the power cord is not plugged into an electrical outlet when working on the saw.

### STEP ONE — INSTALLATION AND ADJUSTMENT OF TABLE SUPPORTS

1. Place the saw on a work bench or table.
2. Attach right-, and left-hand table supports to the saw base as follows: (See figure 2.)

**NOTE:** Right-, and left-hand supports may be identified by the three "keyholes" in the table attaching surface of each support. These keyholes are for attaching the table clamps and are located at the rear of the saw. Also, the angle of each support turns outward, away from the saw base. (See figure 2.)

- a. Place one 5/16-inch, split lockwasher and one 11/32-inch plain washer on each of the four 5/16-18 x 3/4-inch, hex-head screws, all from the loose parts pack.
  - b. Attach each table support to the saw base with two of the hex-head screws, lockwashers and plain washers assembled in preceding step.
  - c. Position each support on the base so each screw is approximately centered in the slotted hole in the support.
  - d. Tighten the screws just enough to hold the table supports in position, but loose enough to slip against the base channel when tapped with a plastic mallet.
3. Adjust Table supports parallel to radial arm as follows:
    - a. Loosen the guard clamp screw and remove the guard.
    - b. Lock carriage and hold the motor shaft (at inner edge of saw blade) with the shaft wrench and loosen the

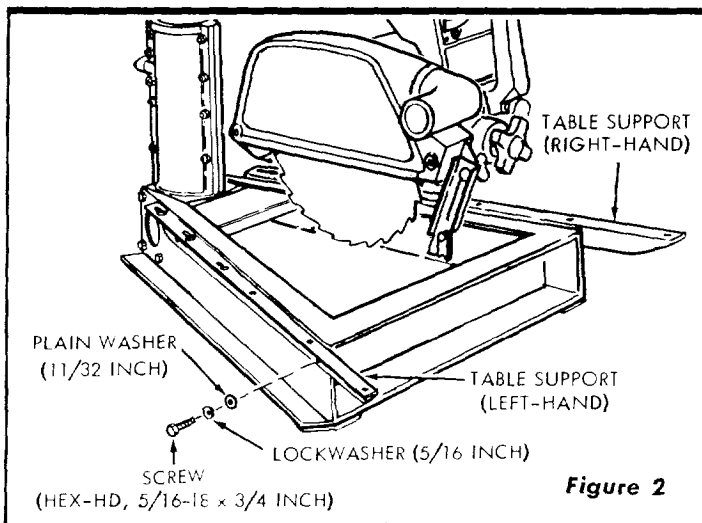

Figure 2

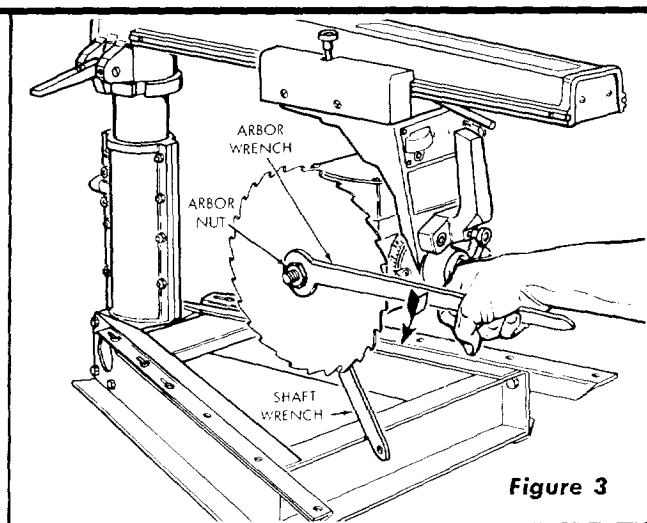

Figure 3

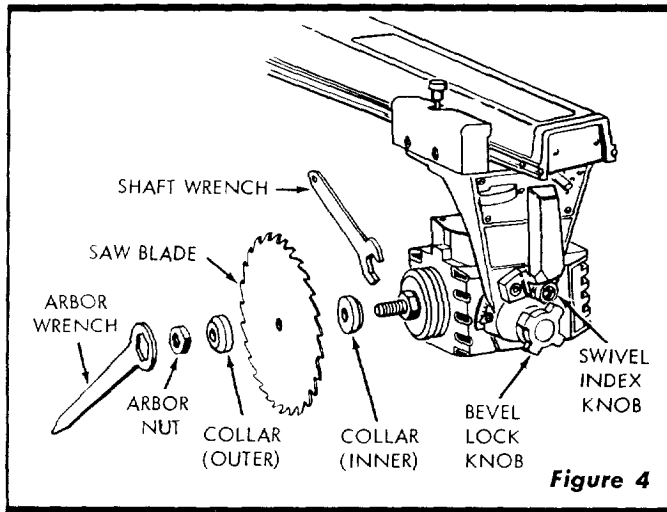

Figure 4

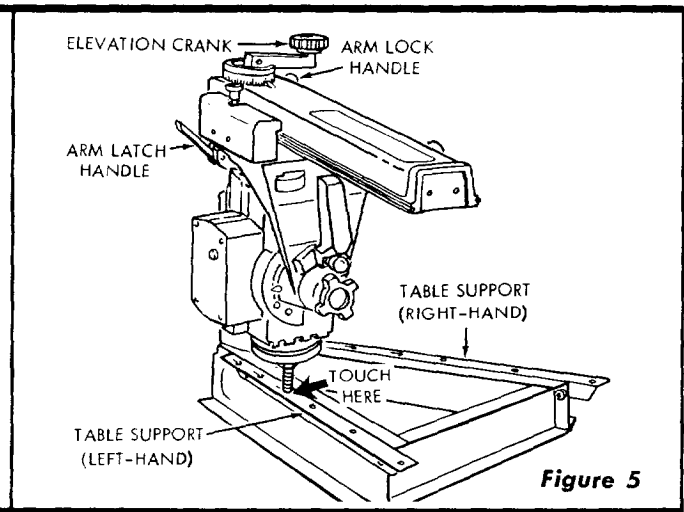

Figure 5

arbor nut and saw-blade collar with the arbor wrench. (See figures 3 and 4). Remove nut, outer collar, saw blade and inner collar. (See figure 4.)

- c. Using the elevation crank (figure 5), raise the motor high enough to swivel  $90^\circ$ , as described in the next step.
- d. Loosen the bevel lock knob and pull out on swivel index knob. (See figure 4.) Swivel the motor to position the saw end of shaft pointing straight down. Tighten the bevel lock knob.
- e. Loosen the arm lock handle (at upper right-hand side of column) and release the arm latch handle (figure 5).
- f. Move the radial arm to the left until the end of motor shaft is directly over the left-hand table support.
- g. Loosen the carriage lock knob and move the carriage rearward as far as it will go. Then, with the elevation crank, lower the carriage until the end of motor shaft just touches the top surface of the left-hand table support.

**NOTE:** Do not change this elevation setting until both left- and right-hand table supports have been adjusted.

- h. Move the carriage out to the end of radial arm and move the arm until the end of motor shaft is over the table support at this position. (See figure 6.) Tap

the table support upward or downward until the end of motor shaft just touches the surface. (See figure 6.)

- i. After setting the forward position of table support, move the carriage rearward and recheck the rearward position to determine if adjusting the forward position affected the rearward setting. Tap the table support upward or downward as required.
- j. Recheck forward and rearward positions as many times as necessary to provide an accurate adjustment of the support.
- k. Tighten the two hex-head screws (figure 2) securely to retain the adjustment. Recheck to make sure that tightening screws did not affect the accuracy of the adjustment.
- l. Move the radial arm over to the right-hand table support and adjust it in the same manner.

#### STEP TWO – ELIMINATING RADIAL ARM SIDE PLAY

1. Move the radial arm to a central (cross-cut) position and engage the arm latch handle in the detent notch. (See figure 7.) Tighten the arm lock handle.

**NOTE:** In order to insure an accurate setting of the radial arm, refer to paragraph entitled "Angular Movement and Locking the Radial Arm", under "OPERATING CONTROLS".

2. Apply side force with one hand on radial arm in both directions. If side play exists, an adjustment is required.

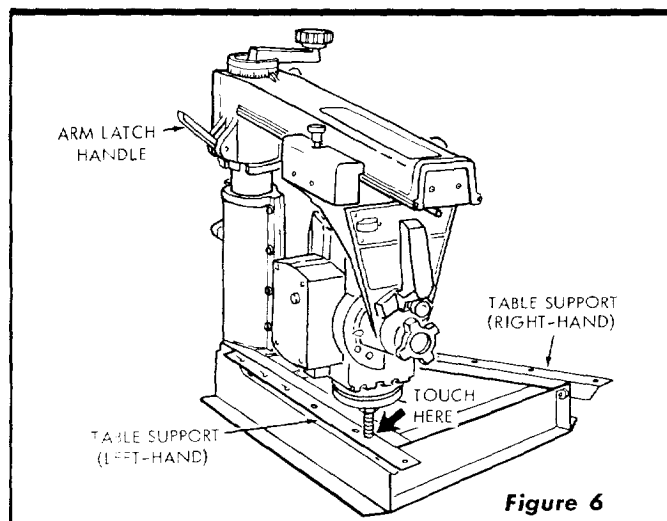

Figure 6

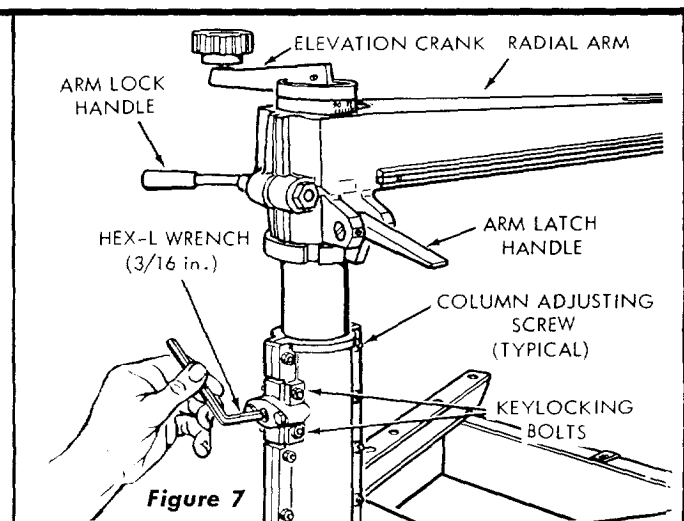
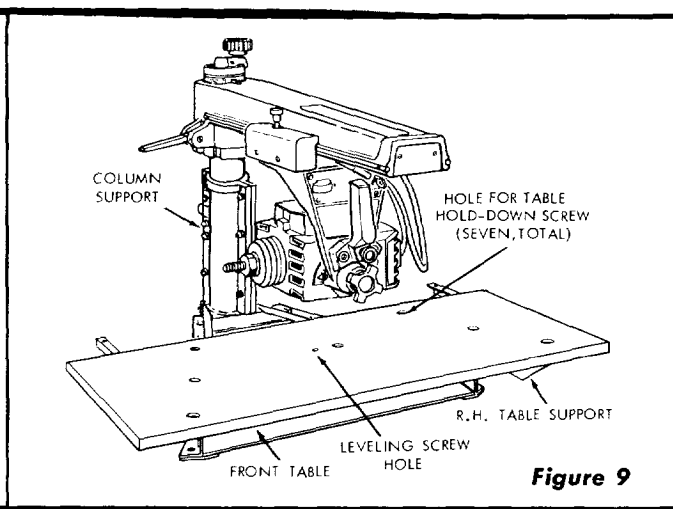
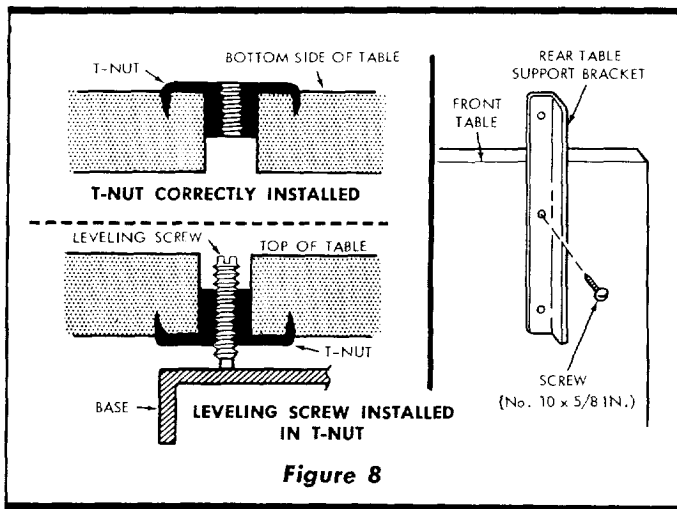

Figure 7



3. Loosen keylocking bolts (See figure 7) and insert a 3/16-inch Hex-L wrench into the socket-head set-screw that adjusts the column tube wedge key, as shown in figure 7. Rotate the set-screw slowly in (clockwise) until no side play can be felt in radial arm.
4. Check for binding by rotating the elevation crank. If the crank rotates with noticeable resistance, loosen the set-screw by rotating the Hex-L wrench counterclockwise until rotation is normal. An effective method for finalizing the set-screw adjustment is to rotate the screw while the elevation crank is being rotated, checking for side play in radial arm as the adjustment progresses. The adjustment is correct when all side play of radial arm is eliminated and only very slight additional resistance can be felt when rotating the elevation crank.
5. If some radial arm side play can still be detected after performing the above adjustment, it will be necessary to adjust the forward five screws through the right-, and left-hand column supports as follows:
  - a. While rotating the elevation crank, tighten the five column adjusting screws slightly at the forward edge of column supports. Each screw should be tightened only slightly, and each one the same amount, until a slight resistance can be felt when rotating the elevation crank, then each screw backed off just enough to restore a normal feel to the elevation crank.
  - b. Recheck the adjustment of the column tube wedge key set-screw as outlined in preceding instructions.

6. After the above adjustments have been completed, recheck the radial arm for absence of side play.
7. When all side play has been eliminated, lock the column tube key in place by tightening keylocking bolts. (See figure 7.)

### STEP THREE — INSTALLATION OF FRONT TABLE

1. Place the large (front) table board upside-down on floor. Distinguish between the one through-bored (leveling screw) hole near the center of the board, and the seven counterbore holes. The counterbores are in the top surface of the board. Drive the T-nut into the through-hole. (See figure 8 which shows the T-nut installed.)
2. With the front table board still in the upside-down position, locate the two pre-drilled screw holes near each end of the table. Attach the two rear table support brackets to the table with two No. 10 x 5/8-inch screws in each bracket. (See figure 8.)
3. Place the 1/4-20 U-clip nut on the base cross member to receive the center front table attaching screw.
4. Place the large, front table board on the table supports. (See figure 9.)
5. Align the counterbore holes with matching holes in table supports.
6. Place a 17/64-inch plain washer and a 1/4-20 x 1-inch pan-head machine screw from loose parts pack in each of the six counterbore holes located above the table supports. Use a 1/4-20 x 1-1/4-inch pan-head machine screw in counterbored hole at the center of the table board.

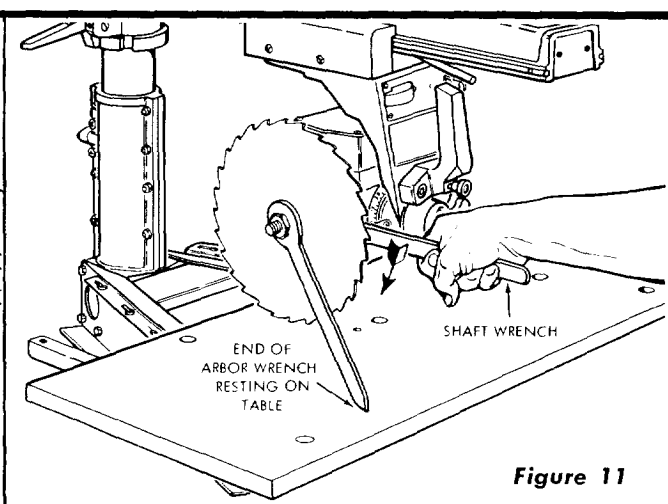
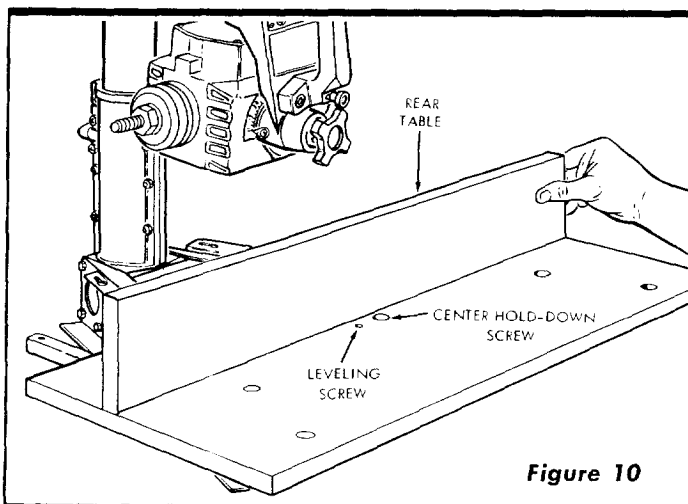

7. Start the leveling screw into the T-nut on front table, but do not allow the tip of the screw to protrude beyond the bottom surface of front table.
8. Install lockwashers and nuts on the six screws in the table supports and tighten them finger tight. Start the pan-head screw in the counterbored hole near the center of front board into the U-nut on saw base, but leave it approximately two turns loose.
9. At this time the front table should be checked and adjusted at the center position as follows:
  - a. Move carriage to maximum rear position.
  - b. Using one edge of the rear table board as a straight-edge, lay the board on the front table as shown in figure 10.
  - c. Sight between edge of rear table and surface of front table, to determine if the front table is low or high at the center position. If front table is high, tighten the center hold-down screw until it is level, then rotate the leveling screw clockwise until it is "snug" against the base front member. If the table is low at the center, loosen the hold-down screw and rotate the leveling screw clockwise until the front table is level, then tighten the hold-down screw.

**NOTE:** After tightening screws, as described above, always recheck to make sure that the front table remains level. In some cases, a final "touch-up" adjustment may be required.

#### STEP FOUR — SQUARING THE CROSS-CUT TRAVEL

1. Loosen the bevel lock knob, pull out on swivel index knob and swivel the motor until the swivel index knob indexes the motor with the shaft in a horizontal (zero) position. Tighten the bevel lock knob.
2. Check to make sure the arm latch handle is securely latched in the detent and the arm lock handle is still tight.
3. Install the saw blade as follows:
  - a. Place the inner collar on motor shaft. (See figure 4.)
  - b. Slide saw blade on motor shaft. Make sure teeth are pointed in direction of saw rotation. (See figure 4.)
  - c. Install outer collar and arbor nut.

**NOTE:** The arbor shaft has left-hand threads.

  - d. Use the shaft wrench on motor shaft and arbor wrench on arbor nut to tighten the nut, as shown in figure 11.
  - e. Lower the saw blade (with elevation crank) until the blade is approximately 1/32 inch above table surface.
4. Place a square on the table as shown in figure 12 and position the saw and square until the leg of the square just contacts a tooth of the saw blade. (Position "A", figure 12.) Mark this tooth with crayon or chalk.
5. When the blade is moved back and forth on the radial arm, the saw tooth "A" should just touch the square at all positions. If saw tooth "A" does not touch the square at all points, make the following adjustments:
  - a. If saw tooth ("A", figure 12) moves away from the square when moving the blade from the rear toward the front of the table, tap the rear edge of front board with a mallet on left side forward until the table is square with the saw blade.
  - b. Reverse this procedure if tooth "A" moves into the square when moving the saw from the rear toward the front of the table.
  - c. Recheck blade squareness and, if correct, tighten the six table hold-down screws securely.
6. After the cross-cut travel has been accurately squared, check the 0° position on the indicator scale of the radial arm cap to determine if the 0° position on the scale is

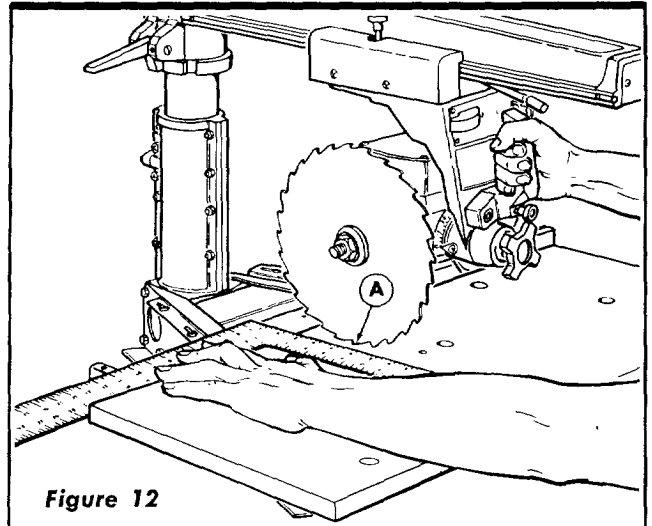

Figure 12

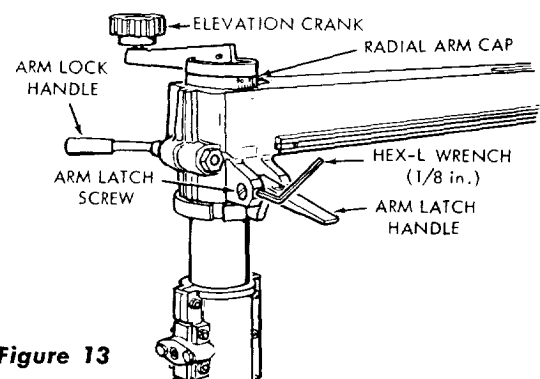

Figure 13

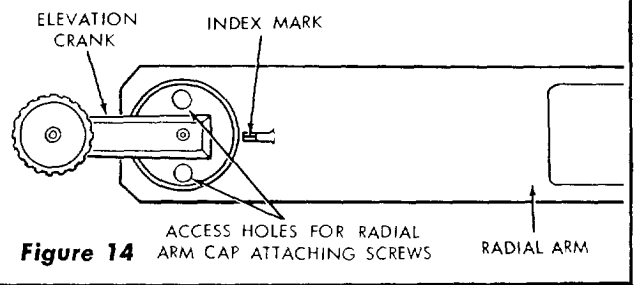

Figure 14

- aligned with index mark on radial arm. (See figure 14.) If not aligned, proceed as follows:
- a. Rotate the elevation crank to a position that will locate the two access holes over screw heads of radial arm cap attaching screws. (See figure 14.)
  - b. Loosen the two screws with a screwdriver inserted through the access holes in elevation crank.
  - c. Reposition the radial arm cap by hand until the 0° mark is aligned with the index mark and tighten the two attaching screws.
7. In extreme cases, due to rough handling during shipment, performing the above adjustment procedure may not be sufficient. Make the following adjustment only after tightening the table hold-down screws and the cross-cut travel cannot be squared by performing the preceding adjustment routine:
    - a. Using a 1/8-inch Hex-L wrench, loosen the two set-screws that lock the arm latch screws. (See figure 13.)
    - b. Move saw blade forward along steel square (figure 12) to determine in which direction the radial arm must be adjusted.

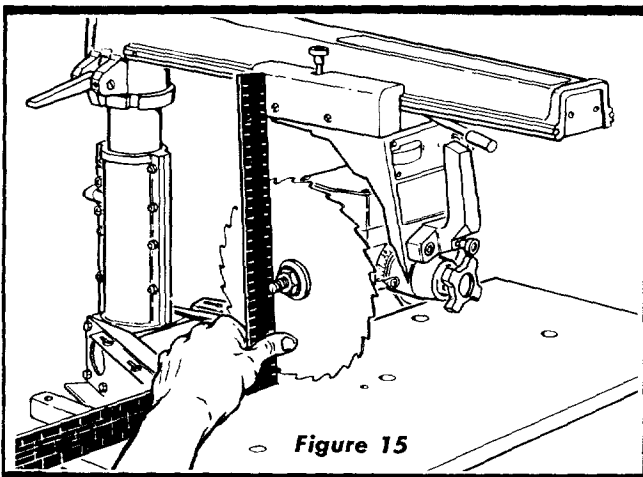

Figure 15

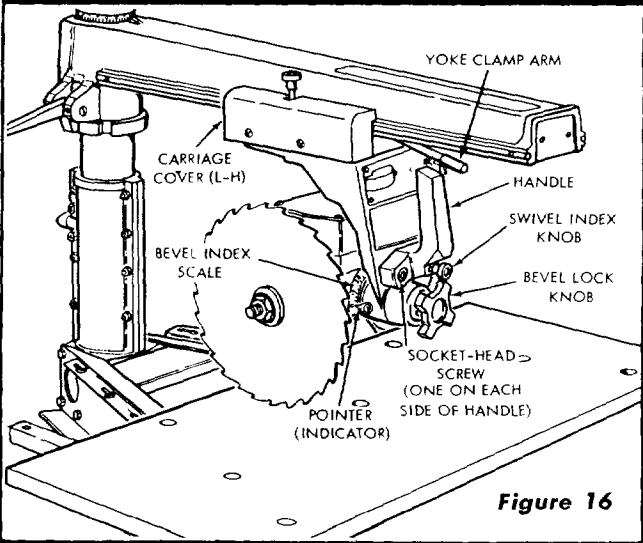

Figure 16

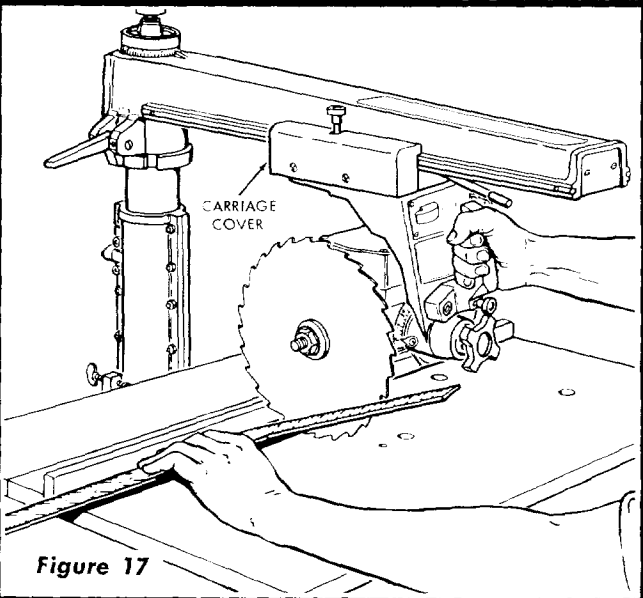

Figure 17

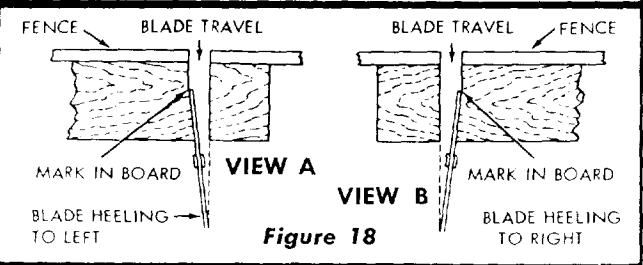

Figure 18

- c. If the saw blade moves away from the square as it comes forward, loosen the front arm latch screw and tighten the rear arm latch screw. Recheck blade travel and repeat if necessary.
- d. If the saw blade moves toward the square as it comes forward, loosen the rear arm latch screw and tighten the front arm latch screw. Recheck blade travel and repeat if necessary.
- e. When the adjustment is correct, both arm latch screws should be snug against the arm latch handle but not tight enough to bind the handle.
- f. Tighten the set-screws to secure the arm latch screws.
- g. Adjust indicator scale, as described in preceding paragraph 6.

#### STEP FIVE—SQUARING THE SAW BLADE TO THE TABLE TOP

1. Place the edge of a framing square on the table top and against the saw blade as shown in figure 15.
2. When the saw blade is square to the table top, no light will be visible between the square and face of saw blade. Do not allow the square to rest against a tooth of the saw. If light is visible between the square and face of saw blade (with square leg held firm against the table top), perform the following adjustments:
  - a. Loosen the bevel lock knob just slightly and, with a 5/16-inch Hex-L wrench, loosen the two socket-head screws that secure the handle to the yoke. (See figure 16.) A screw is located at each side of the swivel index knob.
  - b. While holding the motor with one hand and the square with the other hand, tilt the motor until saw blade is square with table top. Then, while holding the square firmly against the saw blade and table top, tighten the bevel lock knob to hold motor and blade in position.
  - c. Move handle slightly toward left or right until swivel index pin is properly seated. Push firmly against swivel index knob (keeping swivel index pin seated) and tighten the two socket-head screws. The swivel index pin should slide freely in the handle.
 

**NOTE:** It may be necessary to perform more than one trial operation before the saw blade remains perfectly square with table top after tightening the screws.
  - d. The indicators (pointers) should read 0° on the bevel scale. If not, loosen the indicator attaching screws, adjust indicators to zero and tighten the screws securely.

#### STEP SIX—CHECKING THE SAW BLADE FOR HEEL (LEFT AND RIGHT)

1. Place the rip fence against rear edge of front table, place the spacer against the rip fence, then place rear table against the spacer. (See figure 20.) Slide all three items into position so that ends are even with front table.
2. Engage a table clamp in the exposed "keyhole" in each table support and tighten the two clamps to secure all rear table components. (See figure 20.)
3. Place a square against the rip fence and the saw blade as shown in figure 17. The long leg of the square must be held firmly against the rip fence and the short leg must not touch any of the teeth on the saw blade.
4. If a gap exists between the saw blade and the square, one of two types of heel exists. The two types of heel are illustrated in views "A" and "B", figure 18. To correct for either type of heel condition, proceed as follows:
  - a. Remove the left-hand carriage cover by removing the two attaching screws. (See figure 17.)



- b. Loosen the yoke clamp arm. (See figure 16.)
- c. Loosen (slightly) the two hex-head screws at location shown in figure 19.
- d. With the square in position shown in figure 17, shift the yoke until the gap between the saw blade and square is eliminated.
- e. Tighten the yoke clamp arm. Then tighten the two hex-head screws. (See figure 19.)
- f. Recheck for heel (figure 17) to make sure that tightening the hex-head screws did not affect the setting. Several trial settings may be required.
- g. Re-install the left-hand carriage cover.

**NOTE:** If the carriage bearings need adjusting for proper tension on radial arm tracks, refer to "Carriage Bearings" under "Adjustments to Compensate for Wear". If this adjustment is required, be sure to recheck for "heel" after completing the adjustment.

#### STEP SEVEN – DOUBLE CHECK ADJUSTMENTS AND INSTALL GUARD

1. Recheck for correct adjustment on the saw by performing "STEPS ONE through SIX" consecutively.
2. If the cross-cut travel is not perfectly squared, proceed with "STEP FOUR" and make all adjustments listed in the "STEP FOUR" procedure.

#### ADJUSTMENT OF RIP SCALE INDICATORS.

**NOTE:** The rip scales and pointer are intended to be used for quick settings. For greater accuracy, take direct measurement between blade and fence.

1. When the fence is in its normal position (next to the front table), loosen the yoke clamp arm and index the yoke 90° from the cross-cut position so the blade is between the motor and the fence. Lock the yoke by tightening the yoke clamp arm.
2. Loosen the carriage lock knob and move the motor and carriage assembly along the radial arm until the blade, when spun by hand, just touches the front face of the fence. Tighten the carriage lock knob. (See figure 21.)
3. The rip-scale indicator (on the right-hand side of radial arm) should now be aligned with the "0°" mark on the lower ("In-Rip") scale. If not, loosen the two indicator attaching screws and shift the indicator until it is aligned with the "0°" mark, then tighten the attaching screws. (See figure 21.) When the indicator is set for the "In-Rip" (lower) scale, it will be correct for the "Out-Rip" (upper) scale.
4. Loosen the carriage lock knob, move the motor and carriage assembly outward on the arm, enough for the blade to clear the fence. Loosen the yoke clamp arm and index the yoke in the cross-cut position. Tighten the yoke clamp arm.
5. Install the guard assembly, making sure the locating notch on the guard engages with the mating "tongue" on the motor housing. Tighten the guard clamp screw finger tight. (See figure 22.)

#### ADJUSTING SPREADER ON ANTI-KICKBACK ASSEMBLY.

1. Loosen the wing nut (figure 22) and raise the anti-kickback assembly to near maximum height. Tighten the wing nut.
2. Sight (visually) to check for proper alignment of spreader with saw blade, as shown in figure 22. If the spreader is not aligned, adjust it as follows:
  - a. Loosen the two hex-head screws that secure the anti-kickback mounting bracket, shift the spreader into alignment with the blade and tighten the two hex-head screws.

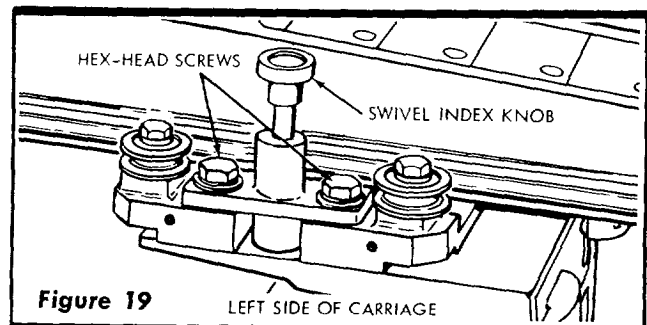

Figure 19 LEFT SIDE OF CARRIAGE

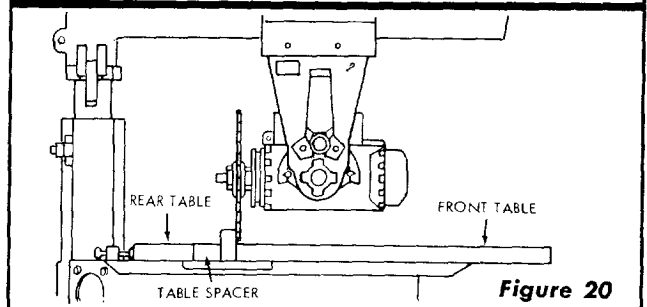

Figure 20

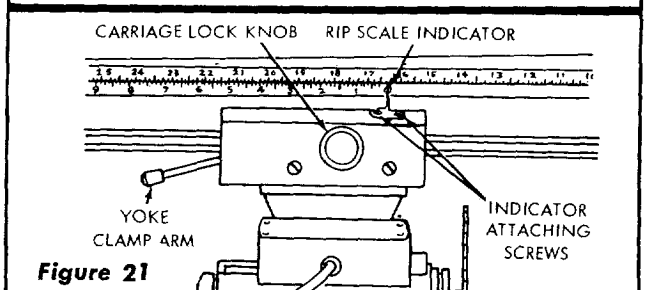

Figure 21

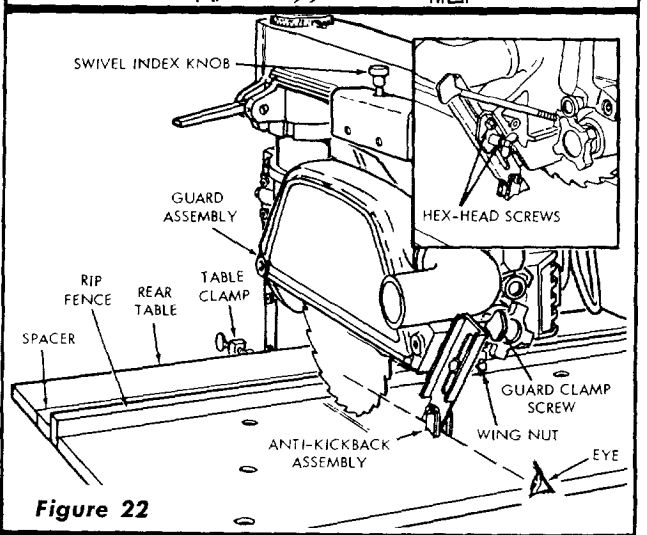

Figure 22

- b. Recheck to make sure that tightening the screws did not affect the setting. Several trial adjustments may be required.
3. Reposition spreader to maximum down position and (sight) check alignment. Adjust position (with two hex-head screws) until in alignment throughout the range.
4. Periodically check and maintain sharp tips on anti-kickback pawls.

**NOTE:** Two detents are "pressed" into the lower end of the spreader to facilitate positioning when ripping. The setting is correct (for anti-kickback pawls and spreader) when upper ends of detents are even with the surface of the board being ripped.

# OPERATING CONTROLS (See figure 23)

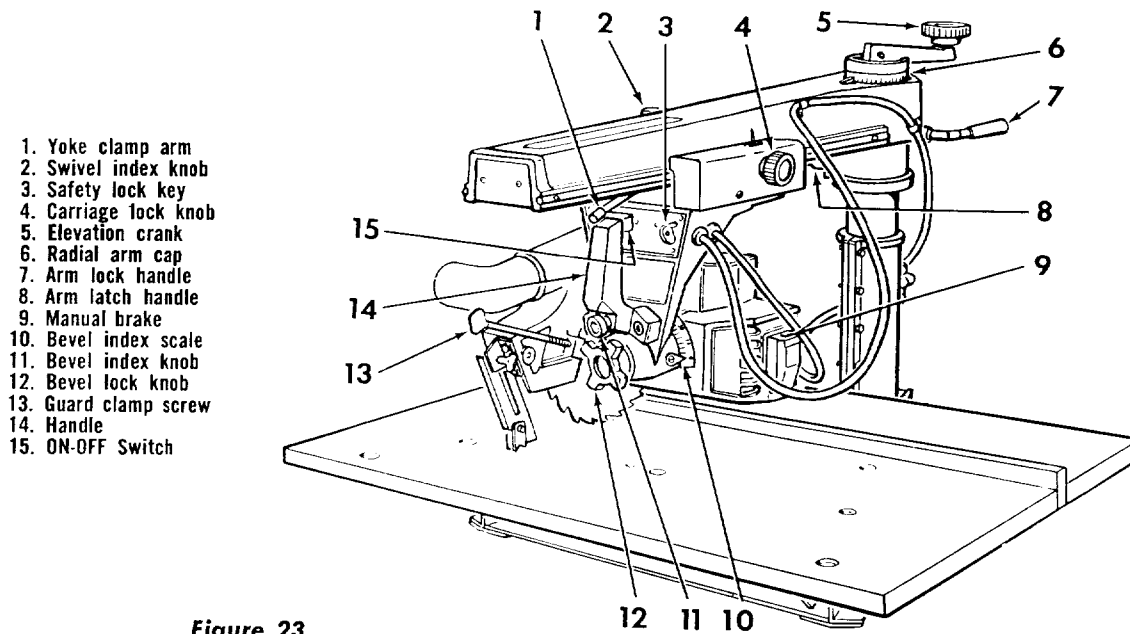

Figure 23

## INSTRUCTIONS FOR USE OF KEY AND SWITCH

1. Insert the key into the slot and turn counterclockwise. (See figure 24.)
2. Hook end of forefinger under the left end of the ON-OFF switch lever and pull the lever out, to start the saw motor. (See figure 24.) To stop the saw, simply "bump" the switch lever with finger or thumb — pushing it inward.

**NOTE:** This saw cannot be operated without the key, and likewise, the key cannot be removed from the lock while the saw motor is running.

**RAISING AND LOWERING THE RADIAL ARM** is accomplished by the elevation crank (5, figure 23). One complete turn of this handle will raise or lower the radial arm 1/8-inch.

**LOCKING THE CARRIAGE TO THE RADIAL ARM** is accomplished by the carriage lock knob (4, figure 23). Turn the knob clockwise to lock; counterclockwise to unlock. Avoid excessive tightening of the knob.

**ANGULAR MOVEMENT AND LOCKING THE RADIAL ARM** are controlled by the arm lock handle (7, figure 23) and the arm latch handle (8). The radial arm can be rotated 360° and locked in any desired position. The arm is unlocked by loosening the arm lock handle and raising the arm latch handle out of the detent notch. It is locked by tightening the arm lock handle. The radial arm has positive stops at 0° and 45°, left and right, and is released from these index positions by raising the arm latch handle. In order to provide the most positive and accurate settings at the index positions, the following is recommended:

1. Move the radial arm into the index position (do not bump or jar) and depress the arm latch handle solidly into the detent notch with the palm of the hand.
2. Lock the radial arm by tightening the arm lock handle fully hand tight.

**NOTE:** The arm lock handle (7, figure 23) is shown on the right-hand side of radial arm. The handle can be removed and re-installed to position it on the left-hand side of the arm, if desired.

**MOVEMENT AND POSITION OF THE MOTOR IN THE YOKE** are controlled by the bevel index knob (11, figure 23) and bevel lock knob (12). The bevel index scale indicates the angular position of the motor with respect to the horizontal position, from 0° to 90°, in either vertical position. The bevel index knob indexes the motor at 0°, 45°, and 90°, up and down. Pull the knob out to release the motor from any of the index positions. At any other position, the bevel index knob is not engaged. The bevel lock knob locks the motor to yoke when the motor is in any position.

**ROTATION AND POSITION OF THE YOKE** are controlled by the swivel index knob (2, figure 23) and the yoke clamp arm (1). The swivel index knob automatically indexes the yoke at each 90° position and both 0° positions. Lift the knob to release it. The yoke clamp arm locks the yoke to the carriage in any position. Push the arm to the right to release it; push to the left to tighten.

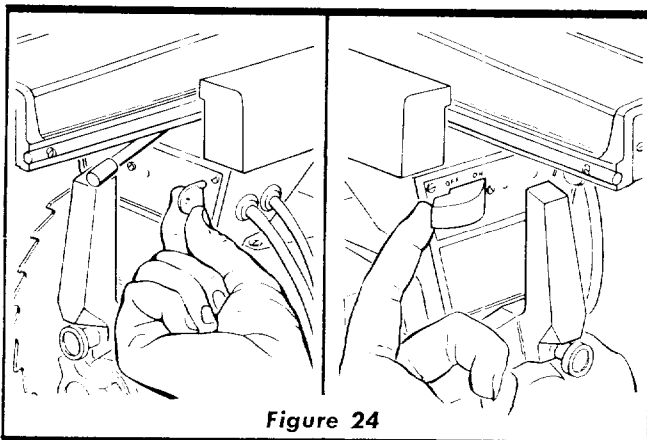

Figure 24

# ADJUSTMENTS TO COMPENSATE FOR WEAR

Even though the finest materials and precision workmanship have been used to minimize wear, after long use it is reasonable to expect some wear. Adjustments have been built into the Craftsman saw to reduce or eliminate this wear.

## REMOVING RADIAL ARM SIDE PLAY

1. Set the radial arm at 0° index position, making sure the arm latch handle is in the detent notch, and tighten the arm lock handle. (See figure 25.)
2. Apply side force with one hand on radial arm in both directions. If side play exists, an adjustment is required.
3. Loosen two locking screws, insert a 3/16-inch Hex-L wrench into the socket-head set-screw that adjusts the column tube wedge key, as shown in figure 25. Rotate the set-screw slowly in (clockwise) until no side play can be felt in radial arm.
4. Check for binding by rotating the elevation crank. If the crank rotates with noticeable resistance, loosen the set-screw by rotating the Hex-L wrench counterclockwise until rotation is normal. An effective method for finalizing the set-screw adjustment is to rotate the screw while the elevation crank is being rotated, checking for side play in radial arm as the adjustment progresses. The adjustment is correct when all side play of radial arm is eliminated and only very slight additional resistance can be felt when rotating the elevation crank.
5. If some radial arm side play can still be detected after performing the above adjustment, it will be necessary to adjust the forward five screws through the right- and left-hand column supports as follows:
  - a. While rotating the elevation crank, tighten the five column adjusting screws slightly at the forward edge of column supports. Each screw should be tightened only slightly, and each one the same amount, until a slight resistance can be felt when rotating the elevation crank, then each backed off just enough to restore a normal feel to the elevation crank.
  - b. Recheck the adjustment of the column tube wedge key set-screw as outlined in preceding instructions.
6. After all adjustments have been completed, recheck the radial arm for absence of side play.
7. When side play is eliminated, tighten the column key locking screws.

## YOKE CLAMP ARM ADJUSTMENT

The normal locking position of the yoke clamp arm (1, figure 23) is parallel with the radial arm. An adjustment will seldom be necessary; however, it may be accomplished as follows:

1. Loosen the carriage lock knob (4, figure 23), move the carriage out to the forward end of radial arm and tighten carriage lock knob.
2. Locate the yoke clamp stud locking screw at the rear of the yoke assembly. (See figure 26.)
3. Turn the locking screw outward at least 1/4-inch from tight position. This frees the index plate (figure 26) which is keyed to the yoke clamp stud, thus permitting the stud to be rotated when the yoke clamp arm is loosened.
4. Loosen the yoke clamp arm and, with pliers lightly gripping the head of the yoke clamp stud, rotate the stud a small fraction of a turn (clockwise when viewed from bottom), then tighten the yoke clamp arm.
5. If the yoke clamp arm still does not line up parallel to the radial arm, loosen it and again move the yoke clamp

stud. Continue this operation until the yoke clamp arm is properly aligned when tightened.

6. Rotate the locking screw back into position to secure the adjustment by preventing movement of index plate.

**NOTE:** It may be necessary to loosen the yoke clamp arm so that end of locking screw can enter a notch of the index plate. This would alter the arm adjustment slightly but not enough to be of any consequence.

## CARRIAGE BEARING ADJUSTMENT

To test for looseness in the carriage, firmly grasp the carriage across the two carriage covers and apply a firm rocking motion. Noticeable looseness may be adjusted as follows:

1. Remove the left-hand carriage cover by removing two attaching screws.
2. Loosen the yoke clamp arm (figure 27), lift up on the swivel latch pin knob and rotate the yoke approximately 45° counterclockwise (when viewed from above) to position the cutout portion of the yoke below the rear carriage bearing, thus providing room for the wrench on the nut.
3. Working on the rear bearing (figure 27), loosen the nut just enough to permit the eccentric screw to turn and rotate it a partial turn (left or right) as required to take up all looseness. Hold the eccentric screw and tighten the nut. The adjustment is correct when there is no "play" between the carriage and radial arm, yet the carriage moves relatively free on the tracks.

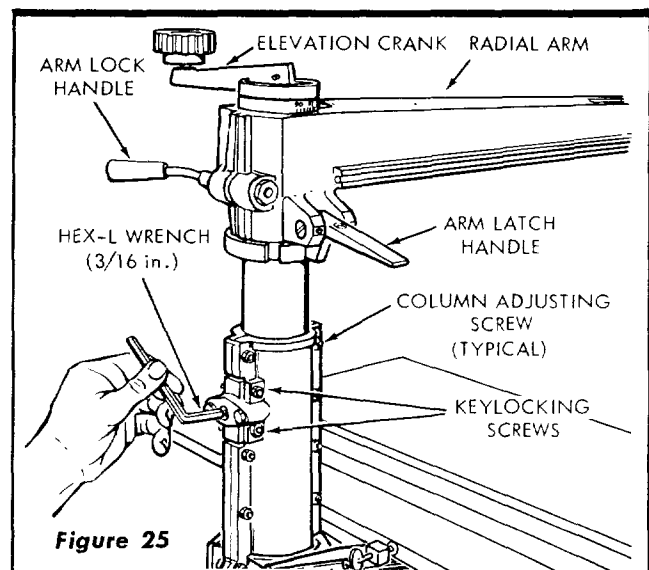

Figure 25

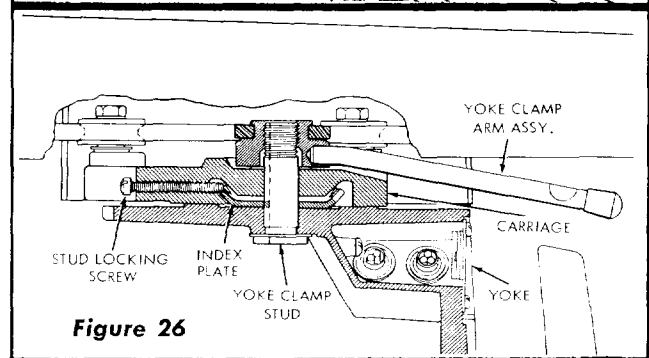

Figure 26

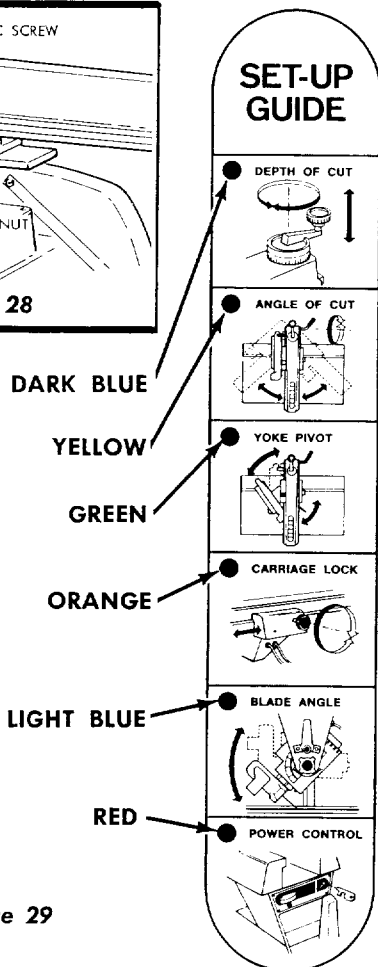
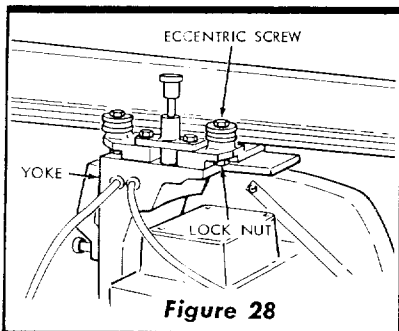
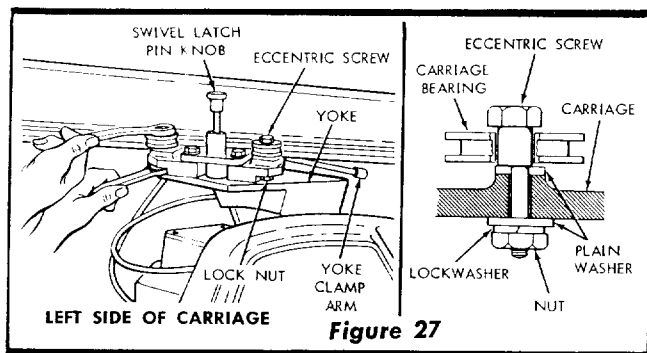

Figure 29

4. Rotate the yoke still farther (figure 28) to position the cutout under the forward eccentric lock nut to provide access for the wrench and adjust the forward carriage bearing as described in preceding instructions.
5. Check the bearing adjustment by grasping the yoke and attempting to "rock" the carriage. If no movement is evident, move the carriage along the radial arm to make sure no binding occurs at any point on the arm.
6. Rotate the yoke clockwise (viewed from above) until it indexes at the crosscut position and tighten the yoke clamp arm.
7. Install the left-hand carriage cover with two screws.

## PROPER OPERATING PROCEDURES CONTROLS

A series of six diagrams are located on the top surface of radial arm in order to designate the controls that must be used in basic "set-ups" and operating procedures. (See figures 23 and 29.) The inexperienced operator should become familiar with these diagrams before operating the saw.

1. "DEPTH OF CUT". The diagram shows the elevation crank (5, figure 23) which is used to raise and lower the blade. A dark blue circle is on the crank handle.
2. "ANGLE OF CUT". Two levers are involved in releasing, securing and indexing the angle of radial arm. These are: arm lock handle (7, figure 23) and arm latch handle (8, figure 23), each marked with a yellow circle.
3. "YOKE PIVOT". Two controls are used in this operation. They are: swivel index knob (2, figure 23) and yoke clamp arm (1, figure 23), each marked with a dark olive green circle.
4. "CARRIAGE LOCK". The carriage lock knob (4, figure 23), is rotated clockwise to secure the carriage on radial arm, and counterclockwise to release it. An orange circle is at the center of the knob.
5. "BLADE ANGLE". The two controls used in angular positioning and indexing of the motor to provide the desired saw blade angle are: bevel lock knob (12, figure 23) and bevel index knob (11, figure 23). A light blue circle is attached to each of these controls.
6. "POWER CONTROL". The ON-OFF switch (15, figure 23) is located in the upper left-hand area of the carriage and has a red circle directly under it.

## LUBRICATION

This Craftsman saw is a fine machine and should be given the best of care. If kept clean and properly lubricated, it will give many years of trouble-free service. Before describing the various points which may periodically require lubrication, IT IS MORE IMPORTANT TO FIRST MENTION THE VARIOUS SPOTS WHICH SHOULD NOT BE LUBRICATED.

### NO LUBRICATION REQUIRED AT THESE POINTS

**Do not lubricate the motor bearings. These are sealed ball bearings and require no added lubrication.**

**Do not lubricate carriage bearings or tracks.**

### PERIODICALLY LUBRICATE THESE POINTS

Use SAE No. 10W-30 auto engine oil and refer to Parts List for locations of parts listed below.

1. Apply a few drops of oil along the swivel index pin only if the pin has a tendency to stick. Remove the left-hand carriage cover and use oil sparingly to prevent it from getting on the ball bearings or races.
2. A light film of oil can be wiped on the face of the column tube and keyway to lubricate the fit between this part and the key and column support.
3. An oil hole is provided in the top of elevation crank to facilitate lubrication of the elevation shaft and radial arm cap bearing surface.
4. The threads on elevation shaft are lubricated by removing the elevation crank and radial arm cap.

# STANDARD SAW OPERATIONS

## PRELIMINARY CROSS-CUT AT THE 0° POSITION

1. Loosen the carriage lock knob (4, figure 23) and move the carriage to position the saw just forward of the rip fence. (See figure 22.)
2. Lower the radial arm until the saw blade just clears the table top.
3. Tighten the carriage lock knob (4, figure 23.)

**CAUTION:** Before making the cut, make sure the arm latch handle (8, figure 23) is fully engaged in the detent notch.

4. Plug in the power cord (if not already connected).
5. Insert the safety lock key (figure 24) and pull the switch lever out to "ON" position.
6. Lower the radial arm, by rotating the elevation crank, until the saw blade cuts into the table top surface to a depth of approximately 1/32-inch.
7. Complete the blade clearance groove in the table and rip fence as follows:
  - a. Grasp the handle (14, figure 23) with the left hand and loosen the carriage lock knob (4, figure 23) with the right hand.
  - b. Slowly pull the carriage with the right hand out to the extreme end of its travel.
  - c. Push the carriage slowly rearward to the extreme end of the travel. This stroke will cut through the rip fence.
  - d. Push the switch to "OFF" position.

## CROSS-CUTTING

Cross-cutting is the sawing of wood across the grain. Boards are sawed with the grain running the length of the board. If a straight cross-cut is desired, the board is placed on the saw table against the fence so that the grain is parallel to the fence. (See figure 30.)

**CAUTION:** Make sure the guard chute is in the maximum raised position before turning on the motor.

**NOTE:** When cross-cutting normal pieces of lumber, the long end of the board should be placed to the left of the saw blade, as the board is normally held by the left hand during the sawing operation.

1. The radial arm must be positioned at 0° as indicated by the radial arm position indicator. The arm latch handle must be indexed and arm lock handle tightened. (Refer to paragraph entitled "Angular Movement and Locking of the Radial Arm".)
2. The yoke must be indexed at the 0° position, making the saw blade perpendicular to the rip fence, and the yoke clamp arm placed in locked position.
3. The motor must be positioned at 0°, as indicated by the bevel scale, and locked.
4. Turn the elevation crank to lower the saw until the blade teeth are approximately 1/32" below the table surface and ride in the saw slot made when performing the "PRELIMINARY CROSS-CUT AT THE 0° POSITION".
5. Push the saw carriage to the rear of the radial arm so the blade is behind the rip fence.
6. Adjust the anti-kickback pawl assembly so it clears the board to be cut.
7. Turn the switch key "ON" and pull out the switch lever to start the saw motor.

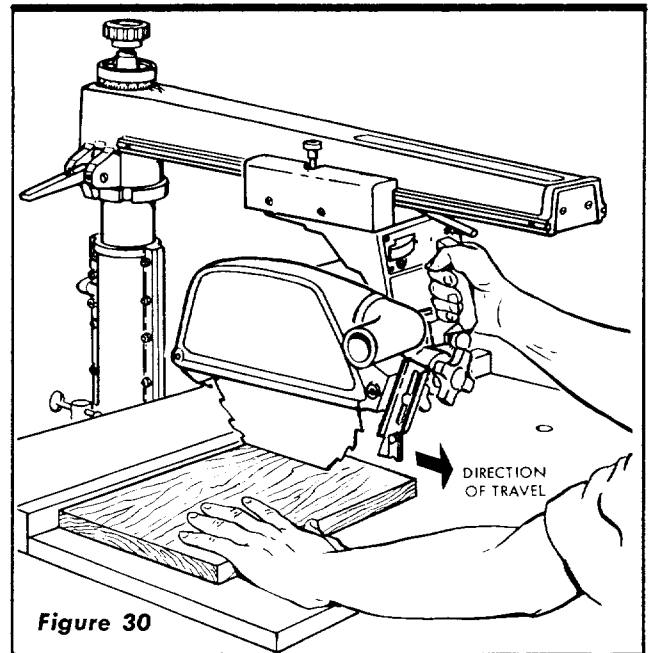

Figure 30

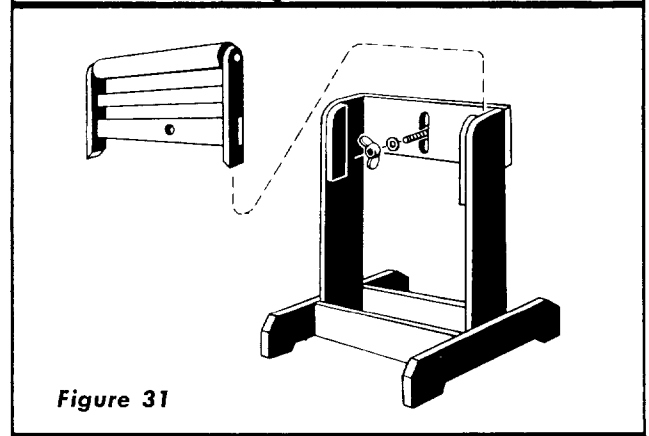
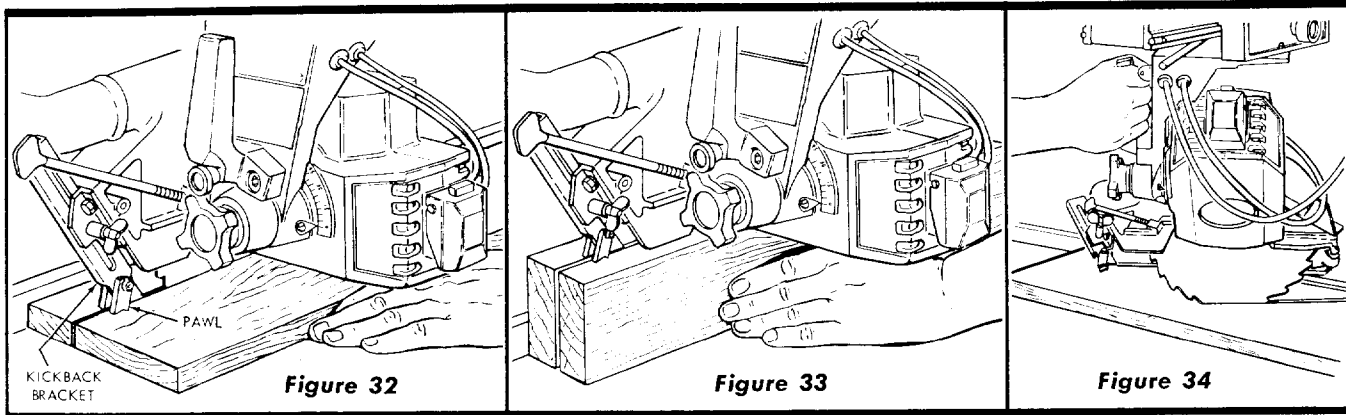

Figure 31

8. Hold the board firmly against the rip fence with the left hand and grasp the handle with the right hand.
9. The cut is then made by pulling the carriage forward until saw blade cuts through the work. When the cut is complete, the saw should be returned to the back of the radial arm and the switch turned "OFF". **When more experience is gained by using the saw, it will be noticed that when pulling the saw forward during cross-cutting, the saw blade tends to feed itself through the work due to the rotation of the blade and the direction of feed. Therefore, the operator should develop the habit of holding his right arm straight from the shoulder to the wrist.** After using this method a few times, the operator will find that it is necessary to roll or rotate the body from the waist up. It will soon become apparent that very little effort is required to move the saw blade through the work, and in most cases, the right arm is used merely to control the rate of feed. It will also be discovered that when cross-cutting a thick board, movement of the saw through the work must be retarded. By holding the right arm (right hand normally grips the saw handle) straight, the operator can easily control the rate of feed, thus preventing the saw blade from overfeeding and stalling the saw motor, which must be avoided whenever pos-



sible. In some cases it may become necessary to cross-cut boards that extend over the saw table on one, or both sides. This can buckle the board and bind the saw during the cut. To eliminate this condition the ends of the board should be supported. Figure 31 shows a typical support that can be easily constructed to facilitate cross-cutting of long boards.

## RIPPING

Ripping is sawing wood with the grain. It is always done with the help of the fence as a guide to position the board and produce the desired width of cut. Since the work is pushed along the fence, it must have a reasonably straight edge in order to make sliding contact with the fence. Also, the work must make solid contact with the table to prevent "wobble" or "rock". A straight edge should be provided, even if it means temporary nailing of an auxiliary straight-edge board to the work. If the work piece is warped, turn the hollow side downward on the saw table.

The guard chute and anti-kickback pawl assembly must always be used in ripping operations. Before ripping, and after the saw has been positioned prior to sawing, the chute and anti-kickback pawl assembly must be properly adjusted. Loosen the chute clamp knob and lower the chute to just clear the top surface of the board to be cut, and tighten the chute clamp knob securely.

**CAUTION:** The guard chute is at the end of the guard which is opposite to the end which mounts the anti-kickback pawl assembly. Always rip from the chute end of the guard. Never adjust the chute with the motor running.

**IN-RIPPING.** "In-rip" refers to a position when the saw blade is between the motor and fence, parallel to the fence. (See figure 32.) To place the saw in this position, unlock the yoke, disengage the swivel index knob and rotate the yoke 90° clockwise (viewing it from the carriage) until the swivel latch pin automatically indexes the yoke at 90°. Lock the yoke securely. Position the carriage on radial arm to provide proper width of cut by measuring from edge of saw blade to rip fence with a scale. Position the discharge elbow on the guard so that sawdust will be blown toward the rear. Turn the saw "ON" and lower the radial arm until saw blade cuts into the table top approximately 1/32-inch and turn the saw "OFF". Adjust the saw guard and anti-kickback pawl assembly as described previously.

The board must be fed into the saw blade from the right side of the table. Therefore, the normal position for the operator is at the right side of table. With the left hand, safely clear of the blade and holding the board down against the table and rearward against the fence, use the

right hand to feed the board into the saw. The left hand should remain stationary, serving as a guide only. As the right hand approaches the left hand, use a push stick in the right hand to complete the cut. Do not leave a long board unsupported so that the spring of the board causes it to shift on the table. (See figure 31.)

**OUT-RIPPING.** "Out-rip" refers to a position when the motor is between the blade and the fence. Normally, this position is used only when the width of the required ripped board cannot be cut from the in-rip position. To place the saw in the "out-rip" position, the yoke must be rotated and indexed 90° counterclockwise from the cross-cut position and locked. The same procedure for pre-setting the table top (see "In-Ripping") and adjusting the chute and anti-kickback pawl assembly (see "Ripping") should be followed. The same procedure for sawing is used except that now the operator stands at the left side of the table and a push stick is normally not required.

## RESAWING

Resawing is cutting thick boards into thinner ones. It is actually a ripping operation. (See figure 33.) Small boards up to 2-inches maximum width can be resawed in one pass. Larger boards up to 4-inches maximum width require two passes, one along each edge of the board. When two cuts from opposite edges are required, they should overlap 1/2-inch from the approximate center of the board. If the first cut is too deep, the kerf will close and bind the saw on the second cut, with some danger of "kickback". Also, when the kerf closes, the two sides of the cut are no longer parallel to the saw blade, and the saw will cut into them and spoil accuracy and appearance. Keep the same face of the board against the fence when making both cuts.

When cutting boards thicker than 3-1/2 inches, a fence should be used which extends 3-inches above the table top. When cutting boards thicker than 4-1/2-inches, cut both sides and finish the cut with a hand saw.

## BEVEL AND MITER CUTS

Bevel cuts can be made from either a cross-cutting or ripping position by tilting the blade to the desired angle. Miter cuts can be made only from a cross-cutting position when the blade and radial arm are at some angle other than 90° to the fence. A bevel miter cut is a cut which is both beveled and mitered. This cut is made with the blade and radial arm set at the desired miter angle to the fence, then the blade (only) is tilted, with respect to the table top, to the desired bevel angle. This cut is usually referred to as a compound miter. (See figure 34.)

## USE OF THE DADO HEAD

The dado saw (or head) is a special set of blades for cutting grooves and dados. The Craftsman 8-inch Kromedge Dado Set may be purchased at any Sears Retail Store or Catalog Order House. The complete head consists of two outside blades 1/8-inch thick, six chipper blades 1/8-inch thick and paper washers for 1/16-inch width adjustments. With these blades, grooves may be made in widths of 1/8-inch, 1/4-inch, and additional widths in steps increased by 1/16-inch each, up to a maximum of 13/16-inch. Outside blades may be used alone, but chippers cannot be used alone. When the maximum 13/16-inch width of dado is used on the motor shaft, the outside loose collar must not be used. The width of the dado can be reduced while using the loose collar and two or more passes may be made with the work to obtain the desired width of cut. Whenever two or more chippers are used, the cutting ends should be staggered as evenly as possible around the circumference. Fractional adjustments in thickness of the head can be made by using paper washers between the outside blades and chippers.

Dado head operations are essentially the same as those operations using a standard saw blade—but the dado head takes a bigger bite, therefore, the work-piece should be held more firmly. When a groove wider than the dado head is needed, make two or more passes, with cuts spaced to overlap a trifle. Dado work is performed in the cross-cut position. Ploughing is done in the ripping position. If the rip or plough position is used, the saw guard and anti-kickback pawl assembly should be adjusted as described in the paragraph "RIPPING". Rabbeting is done with the motor shaft in a vertical position. (See figure 35.) When rabbeting, the motor is indexed 90° to the vertical position so the blades are between the table top and motor, and the yoke is indexed 90° clockwise and locked. The saw is moved back on the radial arm and locked to the arm when the amount of the blade extending forward of the fence is equal to the depth of the rabbet desired. If the depth of the rabbet is large, do not attempt to cut it in one operation. Lower the radial arm until blades are in a position to cut the desired width of rabbet in the edge of the board. The discharge elbow should be directed to the rear of the saw.

## MOLDING OR SHAPING

This work is performed with Craftsman Molding Cutter Heads, and a set of cutters depending on the type of molding cut desired. The saw is positioned in the same manner as that described for rabbeting. (See figure 36.) Since the position of the cutters can be adjusted with respect to the fence and table top, any or all of the cutter shapes may be used.

The Molding Cutter Guard should be used with Molding Cutter Head.

## REMOVAL AND INSTALLATION OF MANUAL BRAKE ASSEMBLY

Prior to performing any operation that requires the use of the motor shaft opposite the saw blade end (routing, dovetailing, boring, sanding, etc.), it will be necessary to remove the manual brake assembly to expose the end of the shaft. This is accomplished as follows: (See figure 37.)

1. Remove the guard assembly, saw blade and both collars.
2. Remove two 1/4-20 x 7/16-inch, hex-head screws to free the brake housing from the motor.

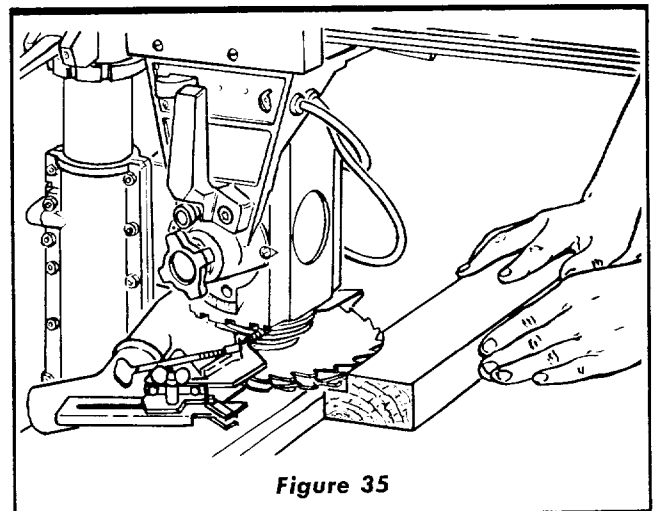

Figure 35

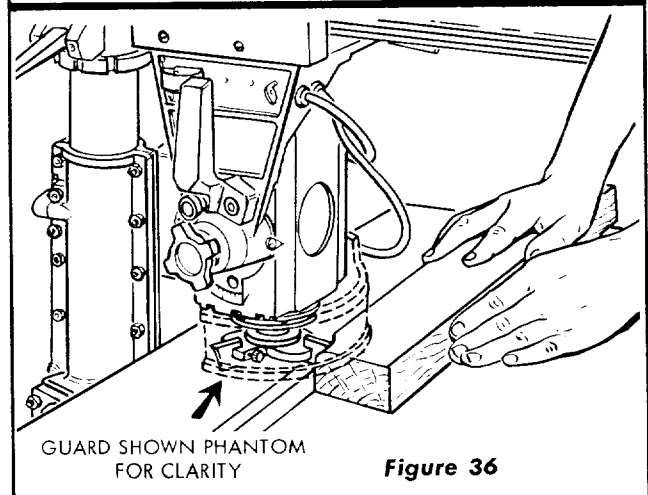

Figure 36

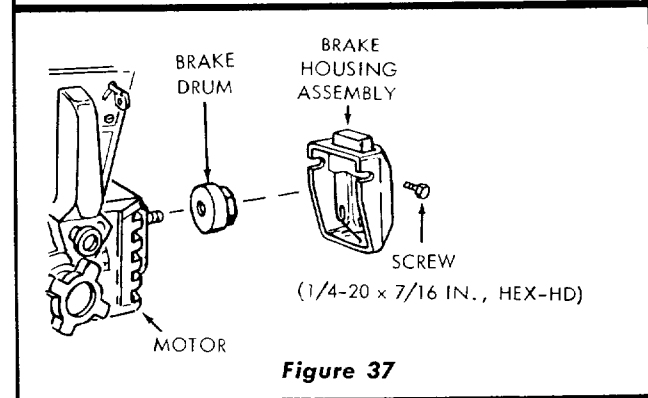

Figure 37

3. Pull the brake housing off end of motor housing, leaving the brake shoe and spring in the brake housing.
4. Hold the motor shaft (at saw end) with the shaft wrench and remove the brake drum from motor shaft with the arbor wrench. (This end of motor shaft has right-hand threads.)
5. Install a chuck or other accessory as required, on end of motor shaft and tighten it firmly on the threads. The motor shaft should be held with the shaft wrench at saw end of shaft while tightening the chuck or other accessory.
6. When finished with the particular operation being performed, install the manual brake assembly by reversing the preceding removal procedure. (See figure 37.)
7. Install saw blade and guard assembly.

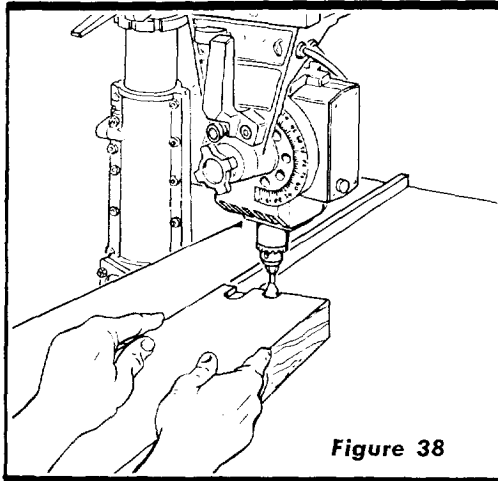

Figure 38

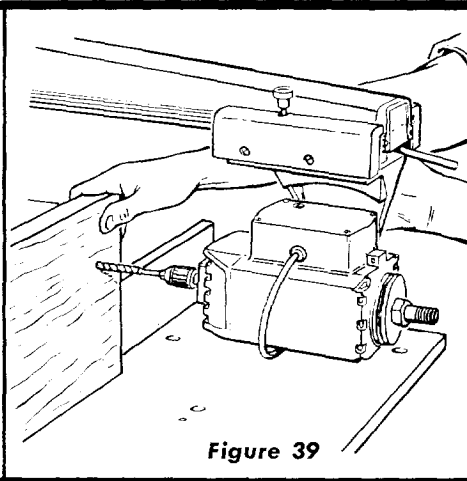

Figure 39

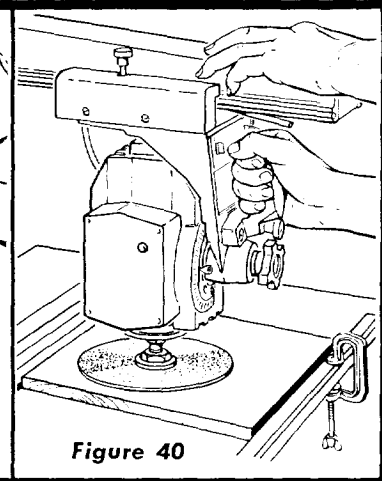

Figure 40

## ROUTING AND DOVETAILING

Routing and dovetailing are accomplished with the motor indexed and locked 90° from horizontal, except that this time the externally threaded stub end (opposite the normal blade end) is between the motor and table top. The following chucks will mate, with this external 1/2-20 thread. (See figure 38.)

0-inch to 1/4-inch Chuck  
5/64-inch to 1/2-inch Key Chuck

The following routers and dovetails are recommended:

1/8-inch router	
1/4-inch router	3/8-inch dovetail
3/8-inch router	1/2-inch dovetail
1/2-inch router	
5/8-inch router	

Routing may be performed by either moving the work with a stationary router, or by clamping the work to the table and moving the router. Always approach the router bit from the left-hand side of the saw.

## BORING

The saw may be converted to a horizontal drill for boring by removing the manual brake assembly and using one of the recommended chucks and proper drill. For drilling holes on an angle, the radial arm should be positioned to the desired angle while the work is parallel to the fence. (See figure 39.) Be sure to install the brake assembly when boring operations have been completed.

## SANDING

Using the sanding disc, mounted on motor shaft, the saw may be converted into a sander that will operate in any position. (See figure 40.)

## HELPFUL HINTS

1. The life of the composition saw table may be greatly lengthened if a 1/4-inch piece of plywood is tacked to the table top after leveling. Then all cutting would be done in the added piece of plywood instead of the table top.
2. There is a possibility that during (or after) shipment, the wood front table; spacer board; or rear table might become slightly warped. Lay a straight-edge across the surface of the table and check for gaps or high spots on the table. Any portions of the table that are not flat should be planed and sanded until flat. Sanding can be done by using one of the two key chucks referred to under "ROUTING" and a Craftsman moulded rubber 6-inch sanding disc.
3. When sanding the table top or routing with the work stationary, the arm latch handle may be prevented from automatically indexing by raising it to the vertical position. (See figure 40.)
4. A scale may be attached to the fence to aid the operator when measuring lengths during cross-cut operations. This is accomplished by tacking a yard stick to the fence as shown. (See figure 41.)
5. In the event the fence is warped and cannot be straightened by tightening the table clamps, proceed as follows:
  - a. Remove the fence and replace it with a temporary fence made from a straight piece of scrap lumber. Proceed to cut slots in the original fence where the gap between the fence and front table was determined to be the greatest. (See figure 42 for slotting arrangement.)
  - b. Replace the fence (after slotting) behind the front table with the slots toward the rear and tighten the table clamps.

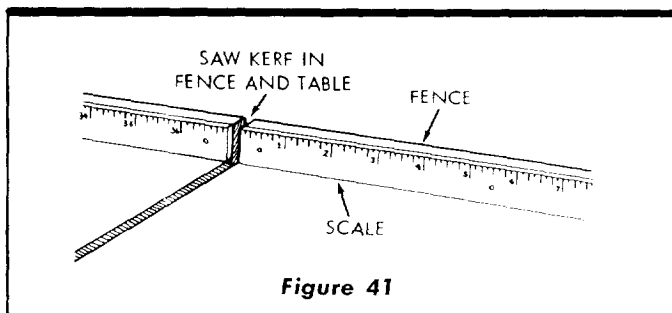

Figure 41

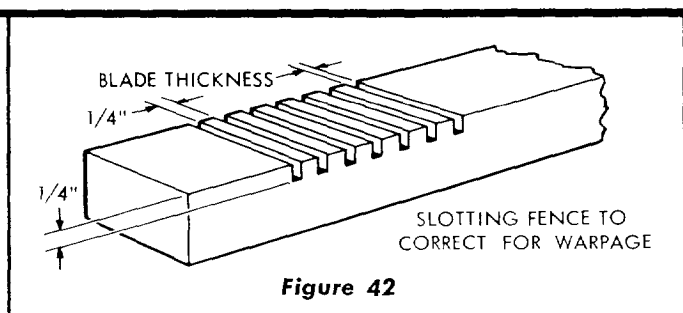
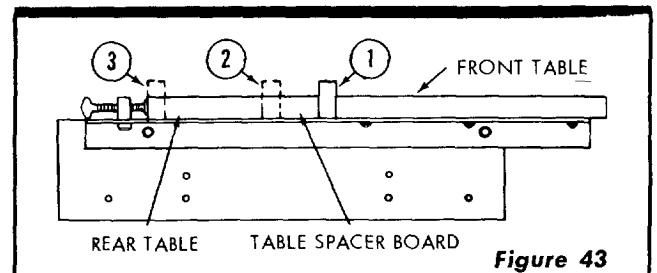

Figure 42



6. There are three positions in which the fence can be located. (See figure 43.)
  - a. Normal position (1, figure 43.)
  - b. Position used for maximum cross-cut on 1-inch material and for greater bevel and miter capacity (2, figure 43).
  - c. Position used for maximum "out-rip" capacity (3, figure 43).
7. Keep all cutting tools, such as saw blades, drills, molding cutters, dados, etc., sharp, and do not "force feed" work enough to drastically reduce motor speed.
8. When using planer, molding, or dado blades, repeated light cuts will produce best results. Deep cuts reduce the quality of the finish and often produce "tear-outs".
9. An auxiliary table top for molding or shaping may be constructed similar to the one shown in figure 44. Notice the shape of the back guide fence which has a cut-out 5-inches wide at the center to provide adequate clearance for the molding head and cutters. Also, a wider clearance (marked "A") should be cut out to allow for the saw motor. Make sure the front edge of the auxiliary table is parallel with the forward surface of the guide fence. The auxiliary table top can be attached to a work bench with "C" clamps.



**Figure 43**

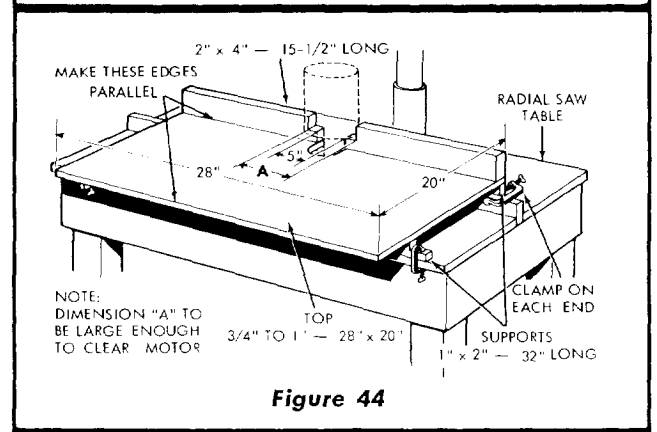

**Figure 44**

**FOR TROUBLE SHOOTING CHARTS  
SEE PAGES 18-19**

**FOR PARTS LISTS  
SEE PAGES 20-26**

# TROUBLE SHOOTING CHART – GENERAL

TROUBLE	PROBABLE CAUSE	REMEDY
Blade "heels" to right or left.	1. Heel has not been taken out of blade.	1. Refer to "STEP SIX – CHECKING THE SAW BLADE FOR HEEL (Left and Right)."
Cannot "rip" properly, wood smokes and motor stops.	1. Dull blade. 2. Cross-cut travel and rip fence are not squared. 3. Radial arm not locked in 0° position. 4. Blade not squared to the table top.	1. Check for sharpness of blade or warped board. Refer to the paragraph entitled "RIPPING." Ripping with hollow-ground blades when boards are badly warped is very difficult. 2. Refer to "STEP FOUR – SQUARING THE CROSS-CUT TRAVEL." 3. Make sure the radial arm is locked and indexed properly in the 0° position. 4. Refer to "STEP FIVE – SQUARING THE SAW BLADE TO THE TABLE TOP."
Work binds when ripping.	Spreader not adjusted.	Refer to paragraph entitled "ADJUSTING SPREADER ON ANTI-KICKBACK ASSEMBLY" and restore correct alignment.
Elevation crank operates roughly; chatter exists.	Column tube key not adjusted properly.	Check adjustment of key plug. Refer to "STEP TWO – ELIMINATING RADIAL ARM SIDE PLAY."
Blade does not maintain constant depth of cut across table.	1. Plane of table top not parallel to horizontal plane through radial arm. 2. Table badly warped.	1. Table is not aligned with radial arm. Refer to "STEP ONE – INSTALLATION AND ADJUSTMENT OF TABLE SUPPORTS." 2. Replace table top.
Blade does not cut squarely, or repeat cuts cannot be secured.	1. Excessive free play in column tube key adjustment. 2. Excessive free play in radial arm. 3. Crosscut travel and rip fence are not squared. 4. Improper movement of arm for miter cuts. 5. Saw blade not square to the table top. 6. Bearings loose on track. 7. Yoke does not index properly. 8. Yoke clamp does not tighten yoke; or looseness is felt in yoke assembly.	1. Refer to "STEP TWO – ELIMINATING RADIAL ARM SIDE PLAY." 2. Eliminate looseness in arm latch screws. 3. Refer to "STEP FOUR – SQUARING THE CROSS-CUT TRAVEL." 4. Adjust arm latch handle for correct indexing at 90° which will produce a correct 45° setting. Refer to "STEP FOUR – SQUARING THE CROSS-CUT TRAVEL." 5. Refer to "STEP FIVE – SQUARING THE SAW BLADE TO THE TABLE TOP." 6. Refer to paragraph entitled "CARRIAGE," under "ADJUSTMENTS TO COMPENSATE FOR WEAR." 7. Check to see that yoke indexes properly and that carriage bearings are not loose on tracks. Refer to "STEP SIX – CHECKING THE SAW BLADE FOR HEEL." 8. Refer to paragraph entitled "YOKE CLAMP ARM ADJUSTMENT" under "ADJUSTMENTS TO COMPENSATE FOR WEAR."

# TROUBLE SHOOTING CHART – MOTOR

**NOTE:** Motors used on wood-working tools are particularly susceptible to the accumulation of sawdust and wood chips and should be blown out or "vacuumed" frequently to prevent interference with normal motor ventilation.

TROUBLE	PROBABLE CAUSE	REMEDY
Motor will not run.	<ol style="list-style-type: none"> <li>1. Protector open; circuit broken.</li> <li>2. Low voltage.</li> </ol>	<ol style="list-style-type: none"> <li>1. Reset protector by pushing in on red button, located on top of motor junction box (indicated by audible click).</li> <li>2. Check power line for proper voltage.</li> </ol>
Motor will not run and fuses "BLOW."	<ol style="list-style-type: none"> <li>1. Short circuit in line cord or plug.</li> <li>2. Short circuit in motor terminal box or loose connections.</li> </ol>	<ol style="list-style-type: none"> <li>1. Inspect line cord and plug for damaged insulation and shorted wires.</li> <li>2. Inspect all terminals in motor terminal box for loose or shorted terminals.</li> </ol>
<b>Motor fails to develop full power.</b> (Power output of motor decreases rapidly with decrease in voltage at motor terminals.) For example: a reduction of 10% in voltage causes a reduction of 19% in maximum power output of which the motor is capable, while a reduction of 20% in voltage causes a reduction of 36% in maximum power output.	<ol style="list-style-type: none"> <li>1. Power line overloaded with lights, appliances and other motors.</li> <li>2. Undersize wires or circuit too long.</li> <li>3. General overloading of power company's facilities. (In many sections of the country, demand for electrical power exceeds the capacity of existing generating and distribution systems.)</li> <li>4. Incorrect fuses in power line.</li> </ol>	<ol style="list-style-type: none"> <li>1. Reduce line load.</li> <li>2. Increase wire sizes, or reduce length of wiring.</li> <li>3. Request a voltage check from the power company.</li> <li>4. Install correct fuses.</li> </ol>
Motor starts slowly or fails to come up to full speed.	<ol style="list-style-type: none"> <li>1. Low voltage — will not trip relay.</li> <li>2. Starting relay not operating.</li> </ol>	<ol style="list-style-type: none"> <li>1. Correct low voltage condition.</li> <li>2. Replace relay.</li> </ol>
Motor overheats.	<ol style="list-style-type: none"> <li>1. Motor overloaded.</li> <li>2. Improper cooling. (Air circulation restricted through motor due to sawdust, etc.)</li> </ol>	<ol style="list-style-type: none"> <li>1. Correct overload condition.</li> <li>2. Clean out sawdust to provide normal air circulation through motor.</li> </ol>
Starting relay in motor will not operate.	<ol style="list-style-type: none"> <li>1. Burned relay contacts (due to extended hold-in periods caused by low line voltage, etc.)</li> <li>2. Open relay coil.</li> <li>3. Loose or broken connections in motor terminal box.</li> </ol>	<ol style="list-style-type: none"> <li>1. Replace relay and check line voltage.</li> <li>2. Replace relay.</li> <li>3. Check and repair wiring.</li> </ol>
<b>Motor stalls</b> resulting in blown fuses or tripped circuit breakers .	<ol style="list-style-type: none"> <li>1. Starting relay not operating.</li> <li>2. Voltage too low to permit motor to reach operating speed.</li> <li>3. Fuses or circuit breakers do not have sufficient capacity.</li> </ol>	<ol style="list-style-type: none"> <li>1. Replace relay.</li> <li>2. Correct the low line voltage condition.</li> <li>3. Replace fuses or circuit breakers with proper capacity units.</li> </ol>
Frequent opening of fuses or circuit breakers.	<ol style="list-style-type: none"> <li>1. Motor overloaded.</li> <li>2. Fuses or circuit breakers do not have sufficient capacity.</li> <li>3. Starting relay not operating (motor does not reach normal speed.)</li> </ol>	<ol style="list-style-type: none"> <li>1. Reduce motor load.</li> <li>2. Replace fuses or circuit breakers.</li> <li>3. Replace relay.</li> </ol>

# PARTS LIST

## CRAFTSMAN, 10-INCH RADIAL ARM SAW, MODEL No. 113.29450

All parts illustrated in Figures 1 through 6 and listed under part numbers may be ordered through any Sears retail mail order store. Order parts by mail from the catalog order store which serves the territory in which you live. In several instances, part numbers are listed for COMPLETE ASSEMBLIES. All parts are shipped prepaid within the limits of the continental United States.

WHEN ORDERING REPAIR PARTS, ALWAYS GIVE THE FOLLOWING INFORMATION AS SHOWN ON THIS LIST:

1. THE PART NUMBER
2. THE PART NAME
3. THE MODEL NUMBER — 113.29450
4. THE NAME OF ITEM — 10-INCH RADIAL ARM SAW

Always order by Part Number — not by Key Number

### FIGURE 1 PARTS LIST

Key No.	Part No.	Description	Key No.	Part No.	Description
1	191230	*Screw, Mach., 1/4-28 x 1, Fill. Hd. Slotted	22	30494	Collar, Saw
2	115109	*Washer, Med. Lock 1/4 S.A.E.	23	60175	†Blade, Saw, 10"
3	63347	Trim, Radial Arm	24	30495	Nut, Shaft
4	30613	Clamp, No. 2 Cord	25	3540	Wrench, Arbor
5	448011	*Screw, No. 8-32 x 3/8, Type 23, Pan Hd., Slotted	26	63062	Wrench, Shaft
6	448001	*Screw, No. 6-32 x 1/4, Type 23, Pan Hd., Slotted	27	63274	Cover, Carriage L.H.
7	63038	Washer, Arm Clamp	28	448905	*Screw, No. 6-32 x 1/2, Type 23, Fill. Hd. Slotted
8	60265	Handle, Arm Lock	29	63034	Track
9	60263	Grip	30	37435	*Wrench, Hex-L, 1/4
10	63346	Arm, Radial	31	60053	*Screw, 5/16-18 x 1/2, Hex. Socket Hd. Cap
11	63348	Panel, Front Trim	32	131201	*Washer, Lock 5/16 x .125 x .078
12	9404351	*Screw, No. 6-32 x 5/16, Type 23, Pan Hd. Slotted	33	63035	Screw, Arm Latch
13	63060	Shoe, Carriage Lock	34	63037	Plug
14	63272	Indicator, Rip	35	222405	*Screw, Set, 1/4-20 x 3/8, Hex. Socket Hd., Flat Pt.
15	9404351	*Screw, No. 6-32 x 5/16, Type 23, Pan Hd. Slotted	36	30505	*Wrench, Hex-L, 1/8
16	63273	Cover, Carriage R.H.	37	63036	Latch, Arm
17	63061	Knob, Carriage Lock	38	118647	Nut, Hex. Jam, 1/2-13 x 3/4 x 5/16
18	63329	Disc Color	39	63258	Elbow, Discharge
19	448013	*Screw, No. 8-32 x 1/2, Type 23, Pan Hd. Slotted	40	63334	Guard Asm. (See Fig. 4)
20	30530	Nut, Twin	41	63183	Cap Asm., Radial Arm. (See Fig. 4)
21	37861	Key	None	63276	Operating Instructions and Parts List for Craftsman 10" Radial Arm Saw Model 113.29450

\* Standard Hardware Item — May be Purchased Locally.

† Stock Item — may be secured through the Hardware Department of most Sears or Simpsons-Sears Retail or Catalog Order Houses.

# CRAFTSMAN, 10-INCH RADIAL ARM SAW, MODEL No. 113.29450

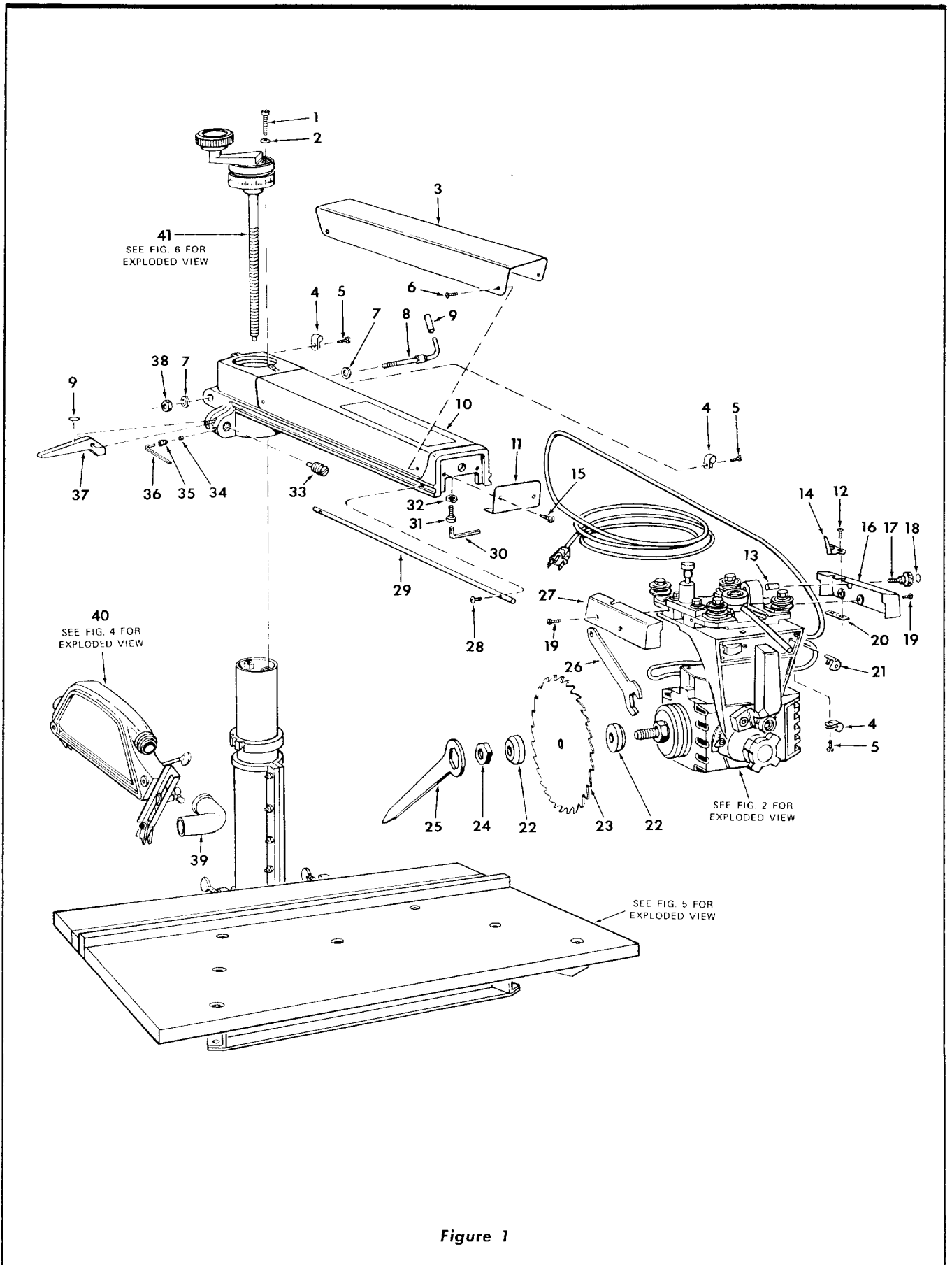
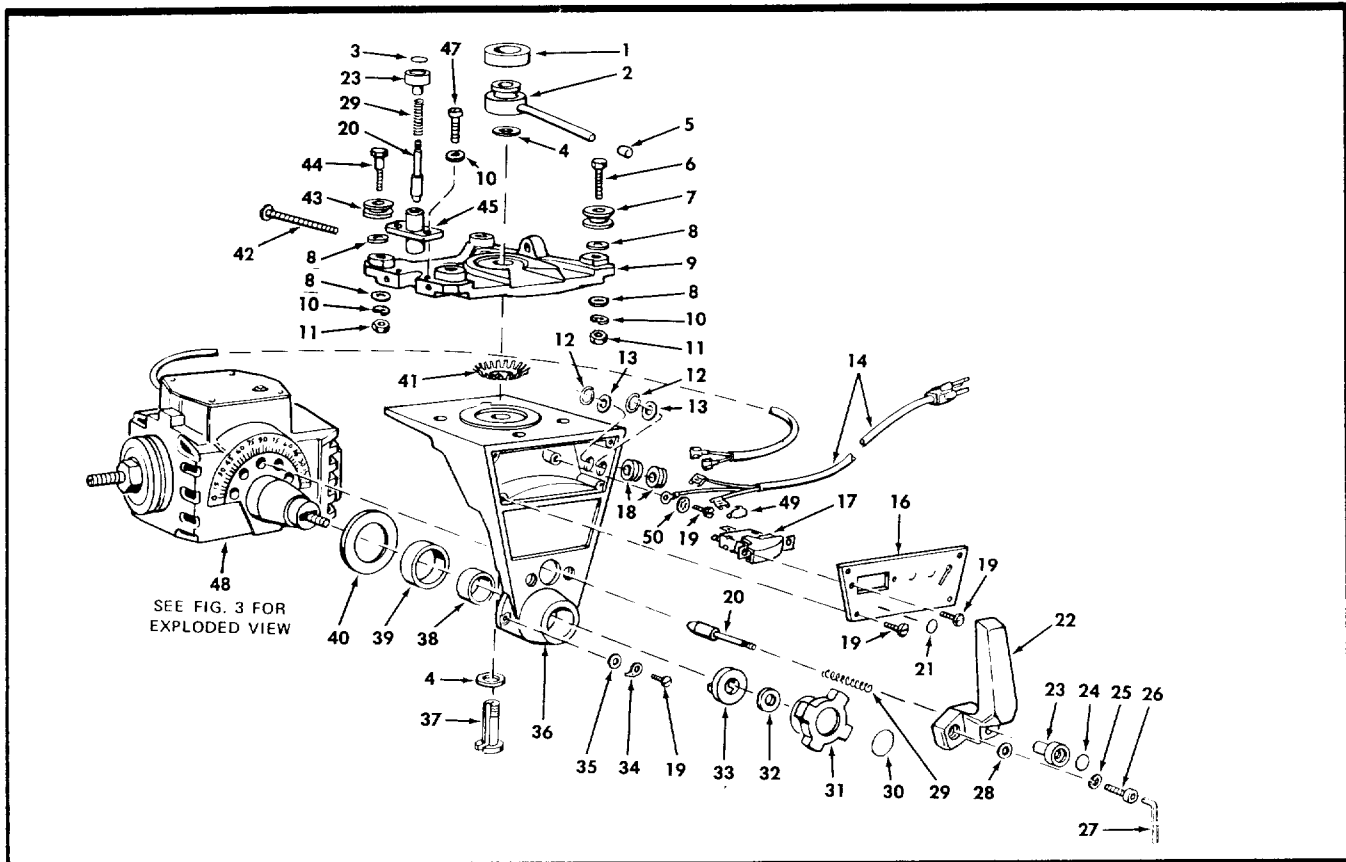

Figure 1

# CRAFTSMAN, 10-INCH RADIAL ARM SAW, MODEL No. 113.29450



**FIGURE 2 PARTS LIST**

Key No.	Part No.	Description
1	63030	Bumper
2	63029	Arm Assembly, Yoke Clamp
3	63327	Disc Color
4	60051	*Washer, Plain, .688 x 1-1/8 x 1-1/32
5	63407	Cap
6	60025	*Screw, Mach., 5/16-18 x 1-1/2, Hex. Ind. Hd.
7	63026	Bearing, Carriage
8	60040	*Washer, Plain, .328 x 3/4 x 1/16
9	63349	Carriage
10	131201	*Washer, Lock, 5/16 x .125 x .078
11	124824	*Nut, Hex., 5/16-18 x 1/2 x 3/16
12	30574	Ring, Hog
13	60055	Washer, Fiber, .380 x 3/4 x 1/16
14	37363	Cord with Plug
16	63343	Plate, Switch Mounting
17	62299	Switch
18	63045	Grommet
19	448001	*Screw, No. 6-32 x 1/4, Type 23, Pan Hd. Slotted
20	63005	Pin, Latch
21	63324	Disc Color
22	63003	Handle
23	63013	Knob, Swivel Index
24	63326	Disc Color
25	131202	*Washer, Lock, 3/8 x .136 x .070

Key No.	Part No.	Description
26	60032	*Screw, 3/8-16 x 1, Hex. Socket Hd. Cap
27	60058	*Wrench, Hex-L, 5/16
28	60031	*Washer, Plain, .440 x 11/16 x 1/32
29	63004	Spring, Swivel Latch
30	63333	Disc Color
31	62275	Knob, Swivel Clamp
32	63011	Washer, Knob Clamp
33	63010	Washer, Clamp
34	63323	Indicator
35	37935	Washer, Fiber, .140 x .250 x 1/32
36	63044	Yoke
37	63027	Stud, Yoke Clamp
38	63006	Bushing, Yoke
39	63007	Bushing, No. 2 Yoke
40	63009	Washer
41	63028	Plate, Index
42	60052	*Screw, Mach., No. 10-32 x 1-1/2, Fill. Hd. Slotted
43	63350	Bearing, Carriage
44	37387	Screw, Eccentric
45	63351	Housing, Latch Pin
47	9415813	*Screw, Mach., 5/16-18 x 3/4, Hex. Ind. Hd.
48	63353	Motor Assembly (See Fig. 3)
49	63467	Cap, Flag Terminal
50	115543	*Lockwasher, No. 6, Internal Tooth

\* Standard Hardware Item — May be Purchased Locally.

† Stock Item — may be secured through the Hardware Department of most Sears or Simpsons-Sears Retail or Catalog Order Houses.

**CRAFTSMAN, 10-INCH RADIAL ARM SAW, MODEL No. 113.29450**

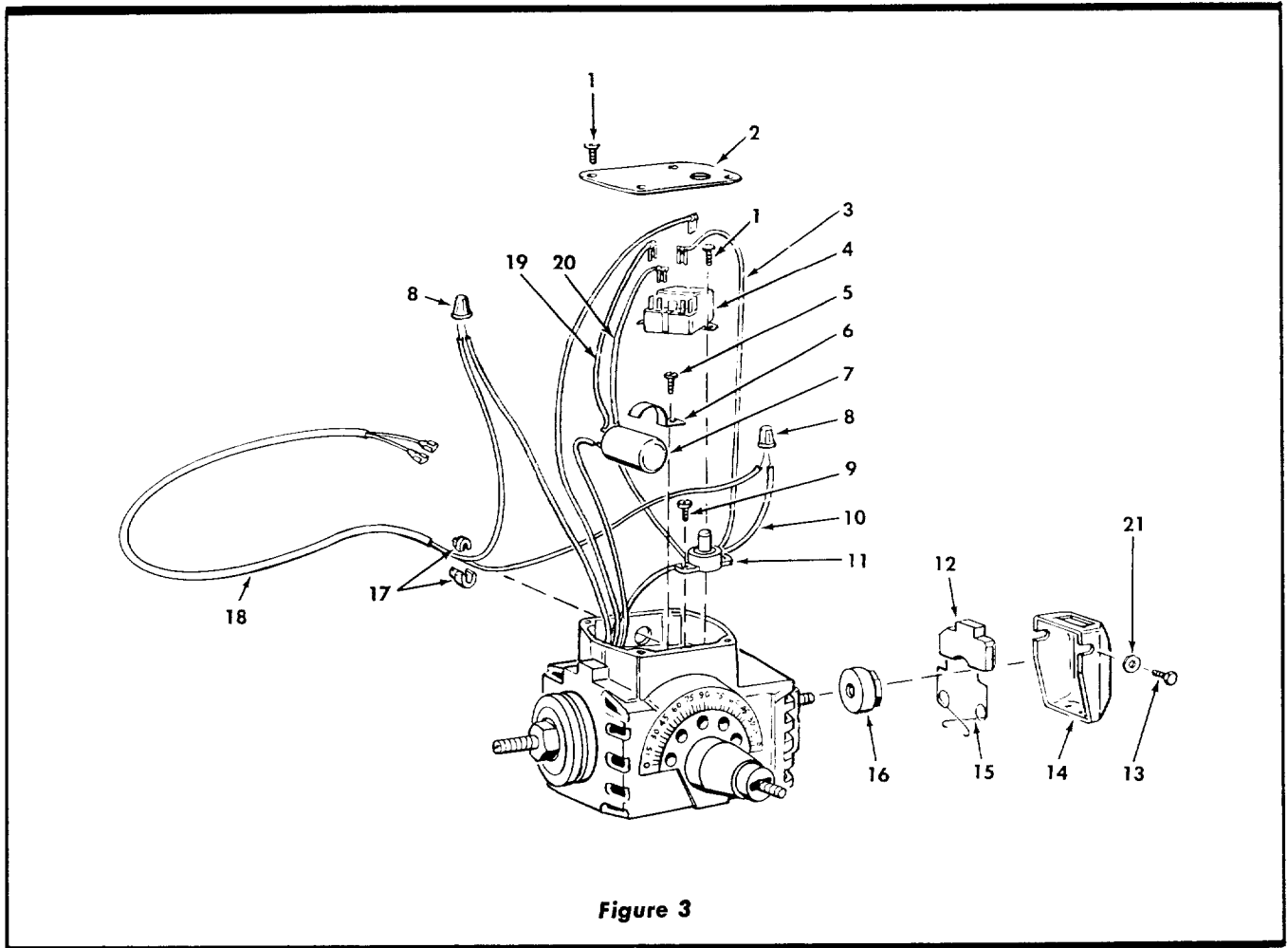

**Figure 3**

**FIGURE 3 PARTS LIST**

Key No.	Part No.	Description
	63353	Complete Motor Assembly (Does not include Cord, Key No. 18)
1	448001	*Screw, No. 6-32 x 1/4, Type 23, Pan Hd. Slotted
2	63354	Cover and Nameplate
3	63066	Lead Assembly (Blue)
4	63355	Relay
5	448011	*Screw, No. 8-32 x 3/8, Type 23, Pan Hd. Slotted
6	30700	Clamp, Capacitor
7	63063	Capacitor
8	37860	*Nut, Wire
9	9404353	*Screw, No. 6-32 x 7/16, Type 23, Pan Hd. Slotted

Key No.	Part No.	Description
10	63068	Lead, Black No. 16 x 4" Long
11	63131	Protector, Thermal
12	65002	Shoe, Brake
13	60021	*Screw, Mach., Hex. Hd. 1/4-20 x 7/16
14	65003	Housing, Brake
15	65001	Spring, Brake
16	65000	Drum, Brake
17	37818	Relief, Strain
18	63352	Cord
19	63065	Lead Assembly
20	63067	Lead Assembly (Black)
21	60089	*Washer 17/64 x 1/2 x 1/32

\* Standard Hardware Item — May be Purchased Locally.

**If parts not listed are required, motor should be sent to the nearest Sears electric motor shop for repair.**

**CRAFTSMAN, 10-INCH RADIAL ARM SAW, MODEL No. 113.29450**

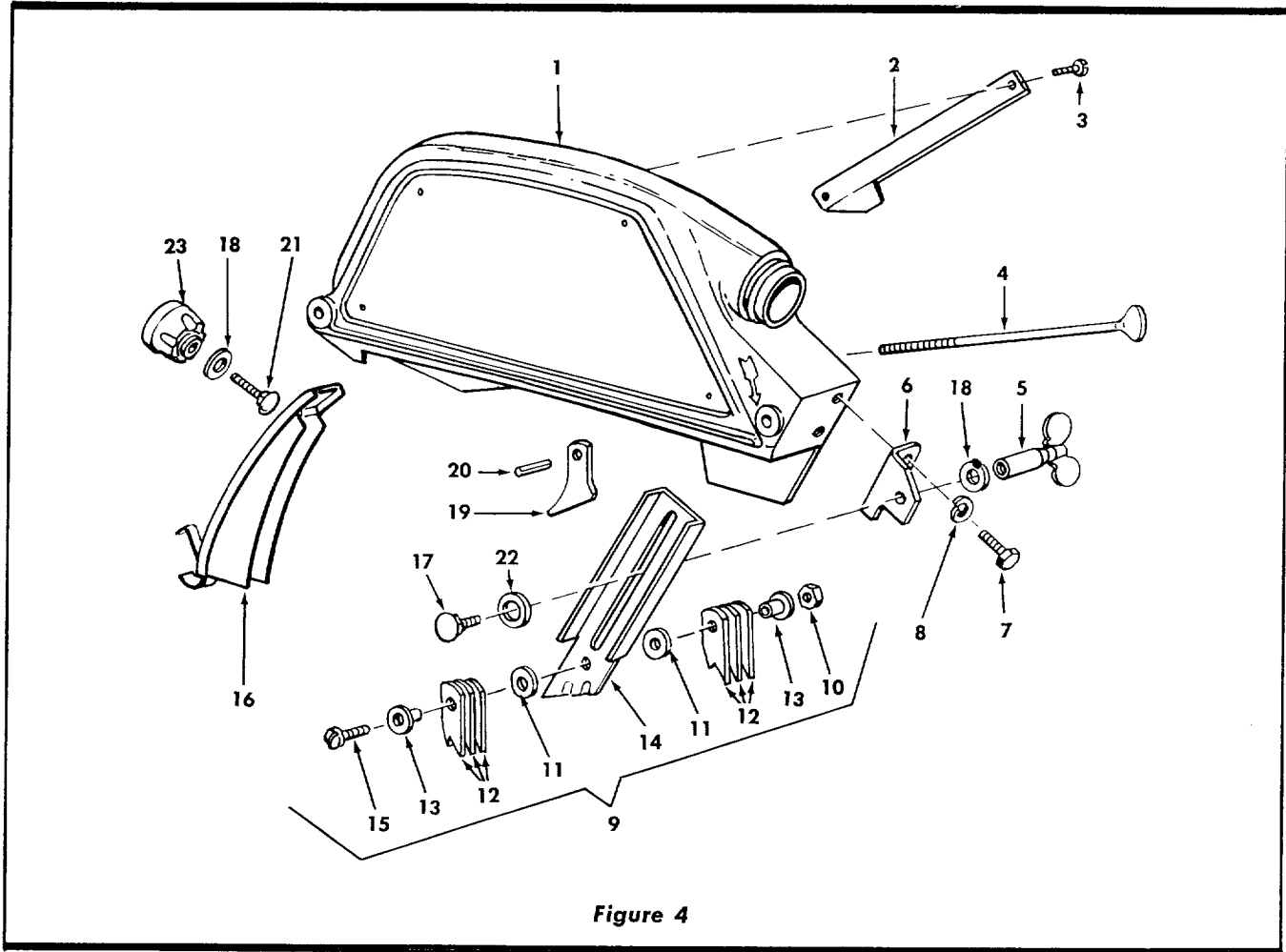

Figure 4

**FIGURE 4 PARTS LIST**

Key No.	Part No.	Description
1	63334	Guard Assembly
	63335	Guard
2	63336	Blade Stop
3	9423400	*Screw, 1/4-20 x 3/8, Pan Hd. Slotted, Self-Tapping
4	63039	Screw, Guard Clamp
5	63339	Nut, Wing
6	63338	Housing, Bracket
7	60078	*Screw, Mach., 5/16-18 x 1/2, Hex. Ind. Hd.
8	131201	*Washer, Lock, 5/16 x .125 x .078
9	63340	Bracket Assembly, Kickback
10	60012	Nut, Lock
11	60041	*Washer, Plain, .198 x 9/16 x 1/32

Key No.	Part No.	Description
12	63271	Pawl, Kickback
13	63341	Bushing, Pawl
14	63342	Bracket, Kickback
15	60243	*Screw, Mach., No. 10-32 x 1-1/8, Pan Hd. Slotted
16	63345	Chute Assembly
17	111137	*Bolt, Carriage, 1/4-20 x 1/2, Rd. Hd., Sq. Neck
18	9414920	*Washer, Plain, 17/64 x 5/8 x 1/16
19	63337	Shoe, Guard Clamp
20	453676	Pin, Roll
21	109091	Bolt, Carriage, 1/4-20 x 1-1/4, Rd. Hd., Sq. Neck
22	60062	*Washer, Plain, .380 x 3/4 x 3/32
23	63344	Knob Assembly

\* Standard Hardware Item — May be Purchased Locally.



**CRAFTSMAN, 10-INCH RADIAL ARM SAW, MODEL No. 113.29450**

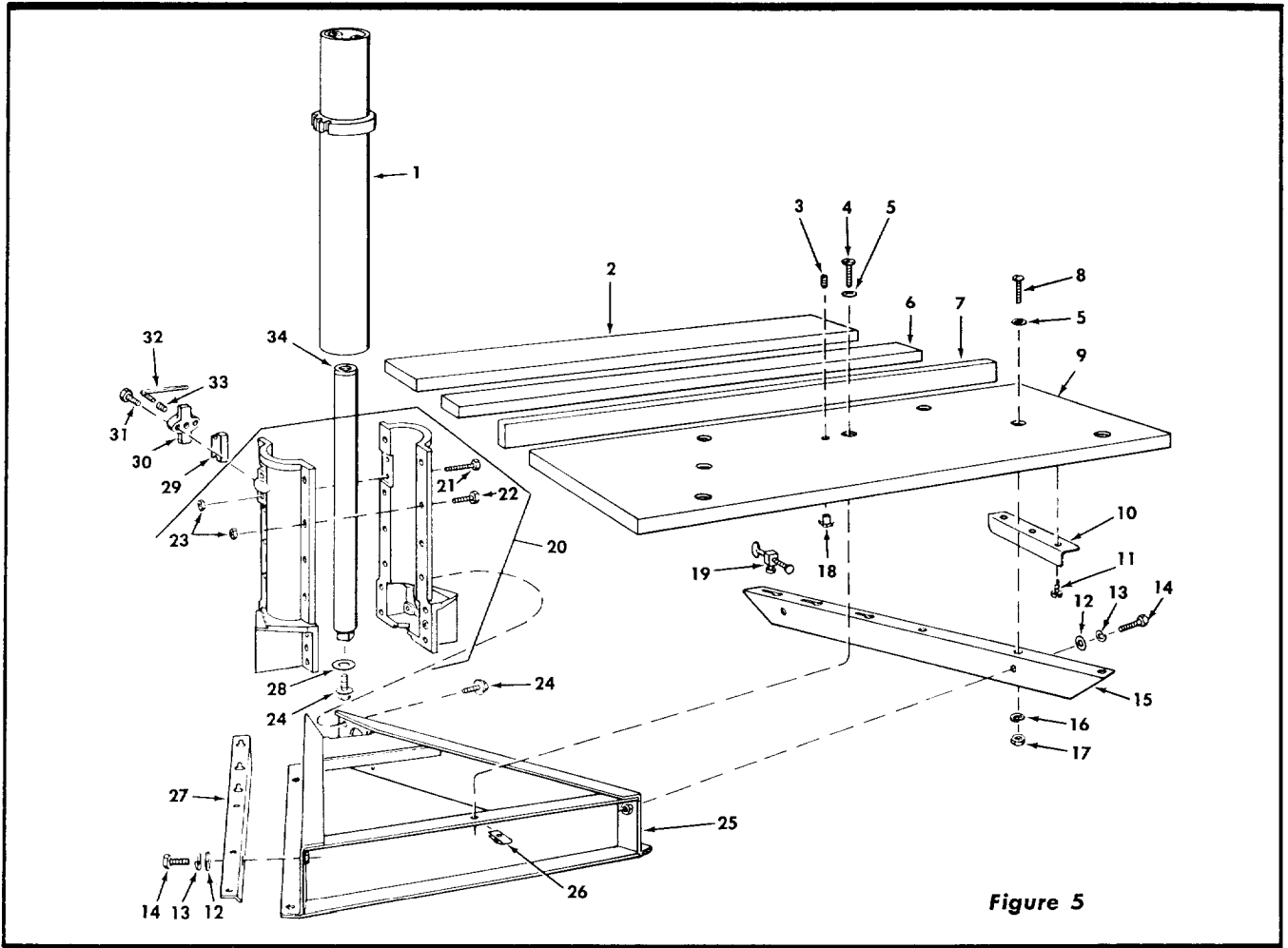

**Figure 5**

**FIGURE 5 PARTS LIST**

Key No.	Part No.	Description
1	63043	Tube Assembly, Column
2	63278	Table, Rear
3	102707	*Screw, Set, Slotted, 1/4-20 x 1/2, Cup Pt.
4	60057	*Screw, Mach., 1/4-20 x 1-1/4, Pan Hd. Slotted
5	60128	*Washer, Plain, 17/64 x 5/8 x 1/32,
6	63279	Table, Spacer
7	63280	Fence, Rip
8	60056	*Screw, Mach., 1/4-20 x 1, Pan Hd. Slotted
9	63277	Table, Front
10	63275	Bracket, Rear Table Support
11	142611	*Screw, No. 10 x 5/8, Type A, Pan Hd. Slotted
12	60013	*Washer, Plain, 11/32 x 7/8 x 1/16, Steel
13	131201	*Washer, Lock, 5/16
14	9415813	*Screw, Mach., 5/16-18 x 3/4, Hex. Hd.
15	63022	Table Support, R.H.
16	115109	*Washer, Lock, 1/4 x .109 x .062
17	115120	*Nut, Hex., 1/4-20 x 7/16 x 3/16

Key No.	Part No.	Description
18	37384	*Nut, "T"
19	63059	Clamp, Table
20	63041	Support Assembly, Column
21	60035	*Screw, 1/4-28 x 1-3/4 Hex. Hd. Ind., Wash. Hd.
22	60034	*Screw, 1/4-28 x 7/8 Hex. Hd. Ind., Wash. Hd.
23	60036	Nut, Lock
24	9416187	*Screw, 5/16-18 x 3/4, Type 23 Hex. Hd. Ind., Wash. Hd.
25	63000	Base
26	37530	Nut, "U" Clip, 1/4-20
27	63023	Table Support, L.H.
28	63056	*Washer, Lift Tube
29	63057	Key, Column Tube
30	63058	Cover, Key
31	60098	*Screw, 1/4-20 x 1, Type 23,* Hex. Wash. Hd. Ind.
32	37911	Wrench, Hex-L, 3/16
33	222506	*Screw, Set, 3/8-16 x 5/8, Socket Hex. Hd., Flat Pt.
34	63042	Tube Assembly, Lift

\* Standard Hardware Item — May be Purchased Locally.

**FIGURE 6 PARTS LIST**

Key No.	Part No.	Description
1	63183	Cap Assembly, Radial Arm
2	63051	Knob, Elevation Crank
3	63052	Shaft, Crank Knob
4	63053	Washer, Knob
5	63054	Ring, Retainer
6	...	†Crank, Lift
7	60030	Washer, .505 x 1 x 1/32
8	453676	Pin, Roll
9	.....	†Cap, Radial Arm
10	.....	†Shaft Assembly, Lift
11	63328	Disc Color

† Purchase as part of Part No. 63183,  
Cap Assembly, Radial Arm.

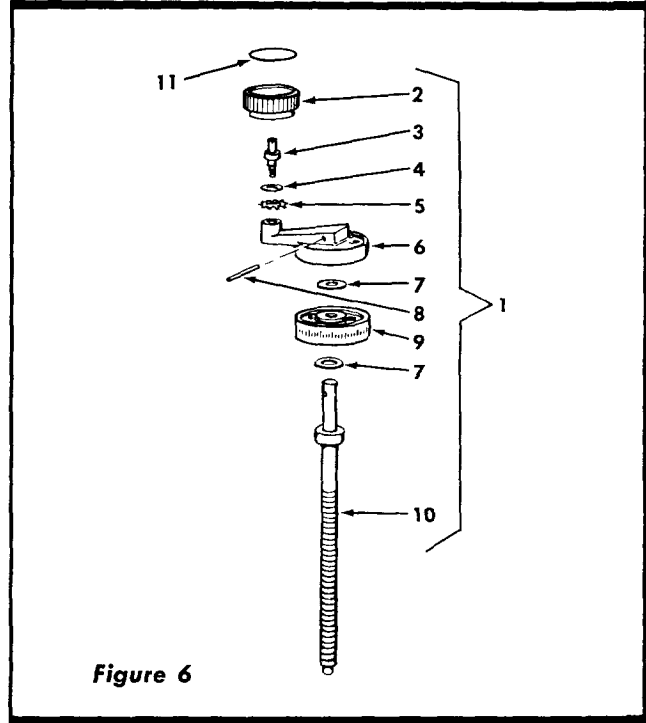

**Figure 6**

**POWER TOOL GUARANTEE**

During the first year, we will repair your Craftsman Radial Saw free of charge, if defective in material or workmanship.

This guarantee service is available by simply returning the saw to any Sears store throughout the United States.

# INSTRUCTIONS TO OPERATOR

Be sure to read the following instructions carefully before operating the saw.

**WARNING: Do not connect power cord until the following steps have been satisfactorily completed:**

- a. Assembly and Installation.
- b. Examination and operating familiarity with ON-OFF switch, elevation control, bevel control, rip control, and miter control.
- c. Review and understanding of the operating procedures which follow.

**CAUTION:** Always disconnect the power cord when changing the cutting tool, changing the set-up, or making adjustments.

**ALWAYS** return the carriage to the full rear position after each crosscut type operation.

1. The saw should be bolted down if there is any tendency to tip over or move during normal operations. The saw table should be approximately 39-inches above the floor.
2. Set carriage lock before moving machine.
3. Raise front of arm by placing a one-inch thick board under the two front legs so the carriage will not roll forward due to gravity.
4. Use only accessories that are designed for this machine.
5. The saw work area should have adequate overhead, non-glare light and adequate surrounding work space.
6. The saw should be positioned when ripping so neither the operator nor a casual observer is forced to stand in line with the saw blade.
7. A large proportion of saw accidents is caused by dull, badly set, improperly filed cutting tools, and by gum or resin adhering to cutting tools. Such conditions cause the material to stick, jam, stall the saw, or kick-back at the operator. Cracked saw blades should be discarded immediately. A saw blade can become cracked if it wobbles or if it is not in balance. Avoid potential injury by proper cutting tool and machine maintenance.
8. Gloves should not be worn while operating the saw. Loose flowing garments, jewelry (rings, wrist watches, etc.), and neckties should never be worn. Long sleeves should be rolled to above the elbows.
9. Goggles or an eye shield should always be used. Ear protectors (ear plugs or muffs) should be used during extended periods of operation.
10. Provide proper support for the workpiece, based on its size and the type of operation to be performed; hold the work firmly against the fence. Use a push stick or board when ripping short work (under 12-inches long), or narrow work.
11. Never hang onto or touch the free end of workpiece or a free piece that is cut off, while power is on.
12. Do not leave a long board unsupported so the spring of the board causes it to shift on the table. A support should be used to catch the end of the board you are not supporting.
13. Never climb on or near the saw when power is on. **Never leave the saw with power on, or before the cutting tool has come to a complete stop. Lock the motor switch and put away the key when leaving the saw.**
14. Avoid awkward hand positions, where a sudden slip could cause a hand to move into a saw blade or other cutting tool. Never reach in back of or around the cutting tool with either hand to hold down the workpiece.

**CAUTION:** Never reposition the dust chute with power **ON**.
15. Always position the dust chute and the anti-kickback pawls for rip type operations. Also make sure the cutting tool, arbor collars and arbor nut are installed properly. Keep guards in place; use the proper guard.
16. Do not use any blade or other cutting tool marked for an operating speed in excess of the design speed of the saw. Never use a cutting tool larger in diameter than the diameter for which the saw was designed. For greatest safety and efficiency when ripping, use the maximum diameter blade for which the saw is designed, since under these conditions the spreader is nearest the blade.
17. The use of abrasive or cut-off wheels, or wire wheels can be dangerous and is not recommended. (Abrasive or cut-off wheels are used to saw many different materials including metals, stone, and glass.)
18. Do not position the arm so the operation you are performing permits the cutting tool to extend beyond the edges of the table.
19. Safety is a combination of operator common sense and alertness at all times when the saw is being used.

**WARNING: Do not allow familiarity (gained from frequent use of your saw) to become commonplace. Always remember that a careless fraction of a second is sufficient to inflict severe injury.**

## CRAFTSMAN 10-INCH RADIAL ARM SAW

**MODEL No.  
113.29450**

### **HOW TO ORDER REPAIR PARTS**

**SEARS SERVICE  
IS AT YOUR SERVICE  
WHEREVER YOU LIVE  
OR MOVE IN THE U.S.A.**

The Model Number will be found on a plate attached to your saw, at the left side of the base. Always mention the Model Number when requesting service or repair parts for your 10-INCH RADIAL ARM SAW.

All parts listed herein may be ordered through SEARS, ROEBUCK AND CO. or SIMPSONS-SEARS LIMITED. When ordering parts by mail, selling prices will be furnished on request or parts will be shipped at prevailing prices and you will be billed accordingly.

**WHEN ORDERING REPAIR PARTS, ALWAYS GIVE THE  
FOLLOWING INFORMATION AS SHOWN IN THIS LIST.**

- |                                  |   |
|----------------------------------|---|
| 1. The PART NUMBER               | 2. The PART DESCRIPTION                         |
| 3. The MODEL NUMBER<br>113.29450 | 4. The NAME of ITEM — 10-INCH<br>RADIAL ARM SAW |

Your Sears merchandise takes on added value when you discover that Sears has over 2,000 Service Units throughout the country. Each is staffed by Sears-trained, professional technicians using Sears approved parts and methods.

## Free Manuals Download Website

<http://myh66.com>

<http://usermanuals.us>

<http://www.somanuals.com>

<http://www.4manuals.cc>

<http://www.manual-lib.com>

<http://www.404manual.com>

<http://www.luxmanual.com>

<http://aubethermostatmanual.com>

Golf course search by state

<http://golfingnear.com>

Email search by domain

<http://emailbydomain.com>

Auto manuals search

<http://auto.somanuals.com>

TV manuals search

<http://tv.somanuals.com>