

SEARS OWNER'S MANUAL

**MODEL NOS.
247.795860
247.795861**

**Caution:
Read and Follow
All Safety Rules
and Instructions
Before Operating
This Equipment**

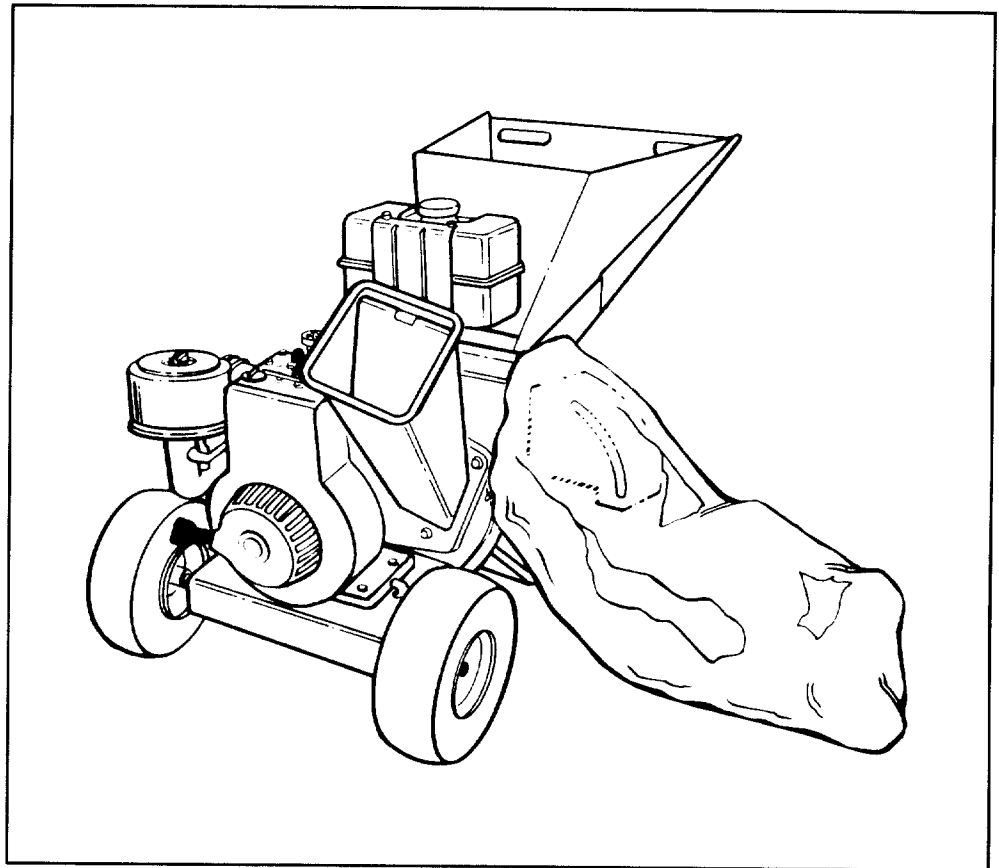

CRAFTSMAN®

**8 HORSEPOWER
3 CUTTING STAGE
MULCHING AND BAGGING
CHIPPER-SHREDDER**

**Assembly
Operation
Customer Responsibilities
Service and Adjustment
Repair Parts**

SEARS, ROEBUCK AND CO., Hoffman Estates, IL 60195 U.S.A.

SAFETY RULES



WARNING: TO REDUCE THE POTENTIAL FOR ANY INJURY, COMPLY WITH THE FOLLOWING SAFETY INSTRUCTIONS. FAILURE TO COMPLY WITH THE INSTRUCTIONS MAY RESULT IN PERSONAL INJURY.

TRAINING

- Read this owner's manual carefully in its entirety before attempting to assemble or operate this machine. Be completely familiar with the controls and the proper use of this machine before operating it. Keep this manual in a safe place for future and regular reference and for ordering replacement parts.
- Children must never be allowed to operate this equipment.
- No one should operate this unit while intoxicated or while taking medication that impairs the senses or reactions.
- This equipment should never be operated in the vicinity of children, pets or other persons.
- Never run your machine in an enclosed area as the exhaust from the engine contains carbon monoxide, which is an odorless, tasteless and deadly poisonous gas.
- Never place your hands or any part of your body or clothing inside the feeding chamber, discharge chute, or near any moving part while the machine or engine is running.
- If it is necessary for any reason to inspect or repair the feeding chamber or any part of the machine where a moving part can come in contact with your body or clothing, stop the machine, allow it to cool, disconnect the spark plug wire from the spark plug and move it away from the spark plug before attempting such inspection or repair.

PREPARATION

- Wear safety glasses provided with your unit while operating the chipper-shredder to prevent injury from any material which may be ejected out of the openings.
- Wear proper apparel. Avoid wearing loose fitting clothing. Wear gloves when handling material.
- **HANDLE GASOLINE WITH CARE** as it is an extremely flammable fuel.
- Check the fuel before starting the engine. Do not fill the fuel tank indoors, while the engine is running, or while the engine is still hot. Turn the unit off and let the engine cool before refueling.
- Fuel your chipper-shredder in a clean area. Do not smoke while refueling.
- Fuel tank cap must be secure at all times except during refueling.
- Avoid spilling gasoline or oil. Wipe the unit clean of any spilled fuel or oil.
- Store fuel and oil in approved containers, away from heat or open flame, and out of reach of children.
- This machine should be operated only upon a level surface.
- Assure that all screws, nuts and bolts and other fasteners are properly secured.

OPERATION

- When feeding shreddable material into this equipment, be extremely careful that pieces of metal, rocks, bottles, cans or other foreign objects are not included. Personal injury or damage to the machine could result.

- If the cutting mechanism strikes any foreign object or if your machine should start making an unusual noise or vibration, immediately stop the engine, disconnect the spark plug wire from the spark plug and move it away from the spark plug. Allow the machine to stop and take the following steps:
 - Inspect for damage.
 - Replace or repair any damaged parts.
 - Check for any loose parts and tighten to assure continued safe operation.
- The engine must be kept clean of debris and other accumulations.
- Do not allow an accumulation of processed material to build up in the discharge area as this will prevent proper discharge and can result in kick-back from feed opening.
- Never place your hands or any other part of your body or clothing inside the feeding chamber, discharge chute or near any moving part while the engine is running.
- Keep all guards and deflectors in place and in good working condition to assure continued safe operation.
- Always stand clear of the discharge area when operating this machine.
- Keep your face and body back from the feed opening to avoid accidental bounce back of any material.
- Do not over-reach. Keep proper balance and footing at all times.
- The engine governor settings on your machine must not be altered, changed, or tampered with. The governor controls the maximum safe operating speeds and protects the engine and all moving parts from damage caused by overspeed.
- Do not transport machine while engine is running.
- Do not operate engine if air cleaner or cover directly over carburetor air intake is removed, except for adjustment. Removal of such parts could create a fire hazard.

MAINTENANCE AND STORAGE

- When this equipment is stopped for servicing, inspection, storage or to change an accessory, make sure the spark plug wire is disconnected from the spark plug and moved away from the spark plug. The machine should be allowed to cool down before making such inspection, adjustments, service, etc. Maintain your machine with care and keep it clean for the best and continued safe operation.
- Do not use flammable solutions to clean the air filter.
- When not in use, your machine should be stored out of the reach of children. Keep where gasoline fumes will not reach an open flame or spark. For long periods of storage, refer to the "Storage" section of this manual.



LOOK FOR THIS SYMBOL TO POINT OUT IMPORTANT SAFETY PRECAUTIONS. IT MEANS—ATTENTION!!! BECOME ALERT!!! YOUR SAFETY IS INVOLVED.

CONGRATULATIONS on your purchase of a Sears Craftsman Chipper-Shredder. It has been designed, engineered and manufactured to give you the best possible dependability and performance.

Should you experience any problem you cannot easily remedy, please contact your nearest Sears Service Center/Department in the United States. We have competent, well-trained technicians and the proper tools to service or repair this unit.

Please read and retain this manual. The instructions will enable you to assemble and maintain your chipper-shredder properly. Always observe the "SAFETY RULES."

MODEL NUMBER _____
SERIAL NUMBER _____
DATE OF PURCHASE _____

THE MODEL AND SERIAL NUMBERS WILL BE FOUND ON A LABEL ATTACHED TO THE FRAME OF THE CHIPPER-SHREDDER.

YOU SHOULD RECORD BOTH SERIAL NUMBER AND DATE OF PURCHASE AND KEEP IN A SAFE PLACE FOR FUTURE REFERENCE.

CUSTOMER RESPONSIBILITIES

- Read and observe the safety rules.
- Follow a regular schedule in maintaining, caring for and using your chipper-shredder.
- Follow the instructions under "Customer Responsibilities" and "Storage" sections of this Owner's Manual.

PRODUCT SPECIFICATIONS

Horsepower:	8.0
Displacement:	19.44 cu. in.
Fuel Capacity:	1 Gallon (Unleaded)
Spark Plug (Gap .030 in.):	Champion J19LM (or Equivalent)
Magnetron® Ignition Air Gap:	.0125 in.

MAINTENANCE AGREEMENT

A Sears Maintenance Agreement is available on this product. Contact your nearest Sears store for details.

WARNING: This unit is equipped with an internal combustion engine and should not be used on or near any unimproved forest-covered, brush-covered or grass-covered land unless the engine's exhaust system is equipped with a spark arrester meeting applicable local or state laws (if any). If a spark arrester is used, it should be maintained in effective working order by the operator.

In the State of California the above is required by law (Section 4442 of the California Public Resources Code). Other states may have similar laws. Federal laws apply on federal lands. A spark arrester for the muffler is available through your nearest Sears Authorized Service Center (See the REPAIR PARTS section of this manual.)

WARRANTY

ONE YEAR LIMITED WARRANTY ON CRAFTSMAN GAS CHIPPER-SHREDDER

For one year from the date of purchase, when this Craftsman Chipper-Shredder is maintained, lubricated and tuned up according to the instructions in the owner's manual, Sears will repair, free of charge, any defect in material and workmanship.

If this Craftsman Chipper-Shredder is used for commercial or rental purposes, this warranty applies for only 30 days from the date of purchase.

This warranty does not cover:

- Expendable items which become worn during normal use, such as blades, chipper blades, flails, air cleaners, spark plugs and catcher bags.
- Repairs necessary because of operator abuse or negligence, including bent crankshafts and the failure to maintain the equipment according to the instructions contained in the owner's manual.

WARRANTY SERVICE IS AVAILABLE BY RETURNING THE CRAFTSMAN CHIPPER-SHREDDER TO THE NEAREST SEARS SERVICE CENTER/DEPARTMENT IN THE UNITED STATES. THIS WARRANTY APPLIES ONLY WHILE THIS PRODUCT IS IN USE IN THE UNITED STATES.

This warranty gives you specific legal rights, and you may also have other rights which may vary from state to state.

SEARS, ROEBUCK AND CO., D/817WA, Hoffman Estates, IL 60195

TABLE OF CONTENTS

SAFETY RULES	2	STORAGE	13
PRODUCT SPECIFICATIONS	3	SERVICE AND ADJUSTMENT	13-15
WARRANTY	3	TROUBLE SHOOTING	16
INDEX	4	PARTS ORDERING/SERVICE	16
ASSEMBLY	5-7	REPAIR PARTS—CHIPPER-SHREDDER	17, 18
OPERATION	7-10	REPAIR PARTS—ENGINE	19-23
CUSTOMER RESPONSIBILITIES	11, 12		

INDEX

	A		O
Adjustments:		Oil	9
Carburetor	15	Operating Tips	8
Engine Speed	15	R	
Assembly Instructions:		Repair/Replacement Parts	17-23
Catcher Bag	6	Responsibilities, Customer	3, 11-13
Chute Crank Deflector	6	S	
Hopper Assembly	6	Safety Rules	2
Catcher Bag	6, 7	Sharpening	14, 15
C		Service Recommendations	11
Catcher Bag	6, 7	Spark Plug	12
Controls	7	Specifications	3
Customer Responsibilities	3, 11, 12	Storage	13
E		T	
Engine:		Table of Contents	4
Maintenance	11, 12	Trouble Shooting	16
Starting	10	U	
Stopping	8	Unclogging	13, 14
Storage	13	Unpacking	5
F		W	
Fuel	9	Warranty	3
L			
Lubrication	11		
M			
Maintenance:			
Agreement	3		
Schedule	11		
Engine	11, 12		
Chipper-Shredder	11		

ASSEMBLY INSTRUCTIONS

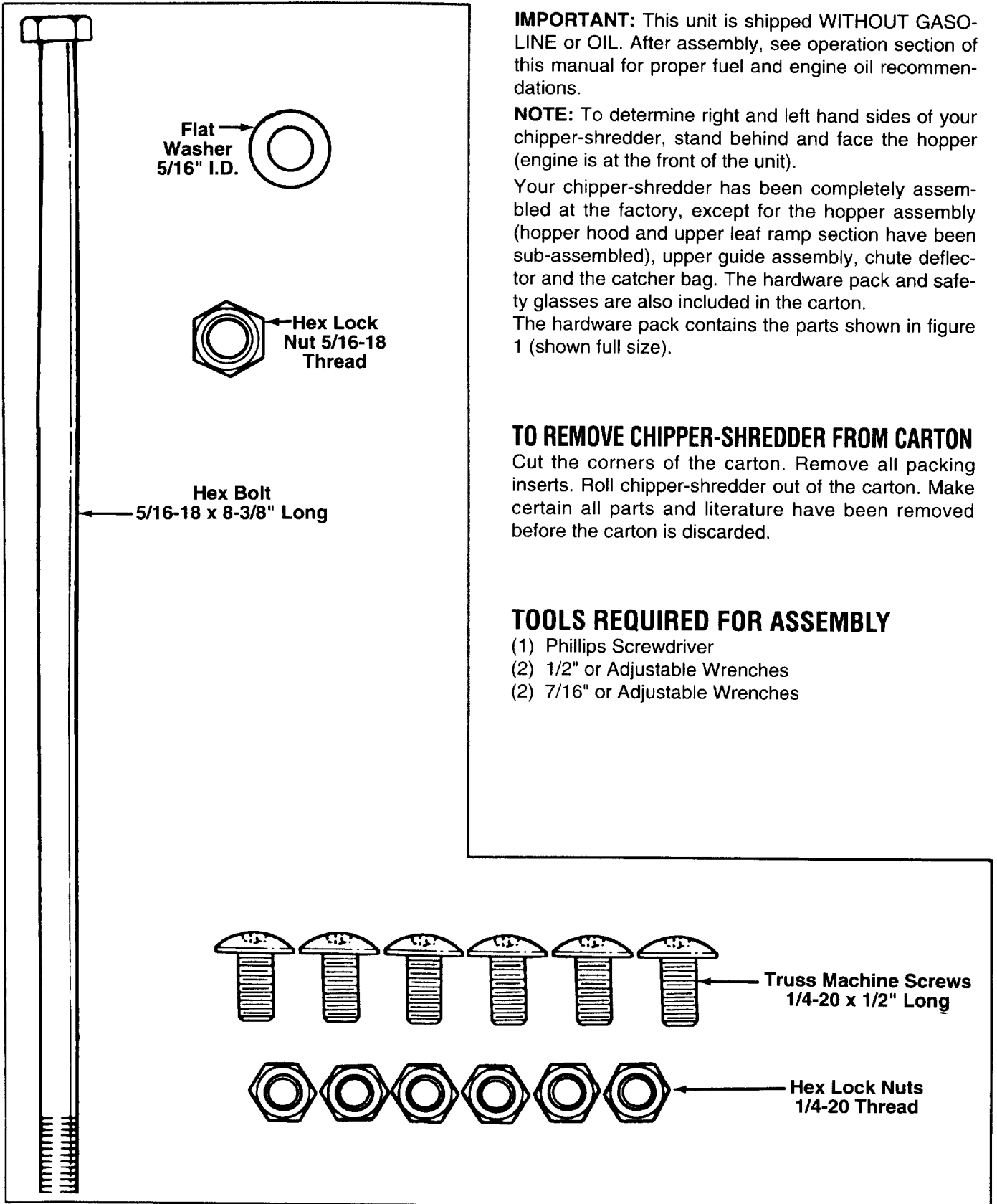

IMPORTANT: This unit is shipped WITHOUT GASOLINE or OIL. After assembly, see operation section of this manual for proper fuel and engine oil recommendations.

NOTE: To determine right and left hand sides of your chipper-shredder, stand behind and face the hopper (engine is at the front of the unit).

Your chipper-shredder has been completely assembled at the factory, except for the hopper assembly (hopper hood and upper leaf ramp section have been sub-assembled), upper guide assembly, chute deflector and the catcher bag. The hardware pack and safety glasses are also included in the carton.

The hardware pack contains the parts shown in figure 1 (shown full size).

TO REMOVE CHIPPER-SHREDDER FROM CARTON

Cut the corners of the carton. Remove all packing inserts. Roll chipper-shredder out of the carton. Make certain all parts and literature have been removed before the carton is discarded.

TOOLS REQUIRED FOR ASSEMBLY

- (1) Phillips Screwdriver
- (2) 1/2" or Adjustable Wrenches
- (2) 7/16" or Adjustable Wrenches

FIGURE 1.

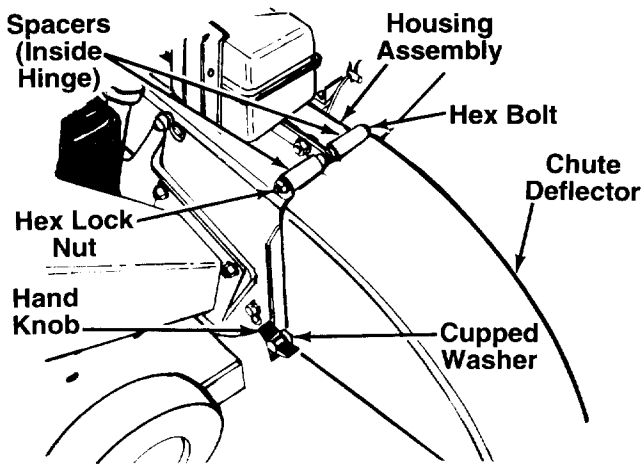

FIGURE 2.

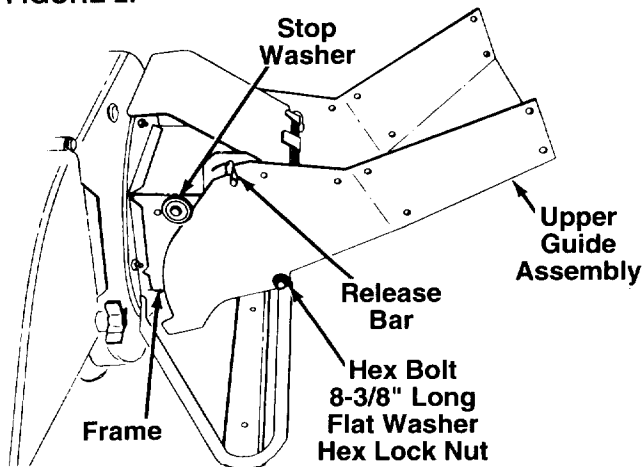

FIGURE 3.

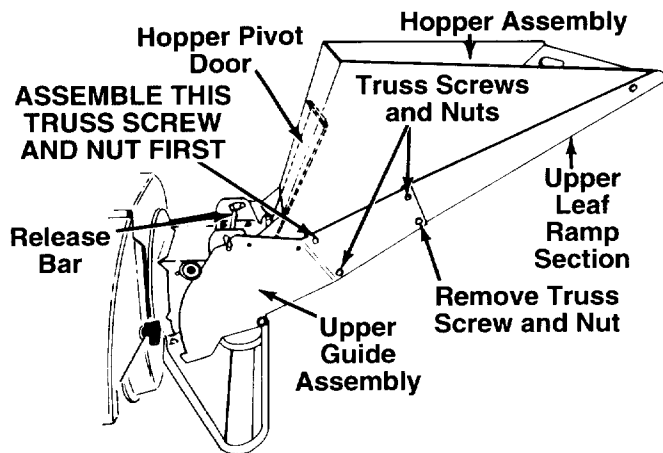

FIGURE 4.

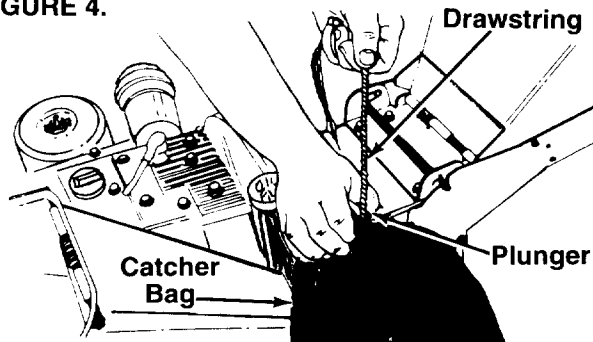

FIGURE 5.

HOW TO SET-UP YOUR CHIPPER-SHREDDER



MAKE CERTAIN THE SPARK PLUG WIRE IS DISCONNECTED AND MOVED AWAY FROM THE SPARK PLUG BEFORE ASSEMBLING THE CHIPPER-SHREDDER.

← ATTACHING THE CHUTE DEFLECTOR

- Remove the hand knobs and cupped washers from each side of the discharge opening on the left side of the chipper-shredder.
- Remove hex lock nut, two spacers and hex bolt from inside the hinge on top of the housing assembly. Do not remove one spacer from the hex bolt.
- Place the chute deflector in position on the discharge opening. Insert hex bolt and spacer through hinge on chute deflector and housing (spacer fits inside of hinge). See figure 2.
- Place second spacer over hex bolt, inside other part of hinge. Secure with hex lock nut. Tighten securely.
- Secure both sides of chute deflector to housing using hand knobs and cupped washers (cupped side of washers go against chute deflector).

← ATTACHING THE UPPER GUIDE ASSEMBLY

Place upper guide assembly in position on frame, making certain edges of the upper guide assembly are underneath stop washers, and the release bar is in the slots. See figure 3. Insert hex bolt 8-3/8" long through upper guide assembly and frame. Secure with flat washer and hex lock nut.

NOTE: Make certain upper guide assembly can pivot by pulling up on release bar and lowering upper guide assembly. If necessary, loosen hex lock nut a turn or two. Put the upper guide assembly back into the raised position.

← ATTACHING THE HOPPER ASSEMBLY

Your chipper-shredder has been shipped with the upper leaf ramp section attached to the hopper assembly. See figure 4. Attach the hopper assembly to the upper guide assembly as follows. Be certain to place heads of all truss machine screws **inside** of hopper assembly.

- Remove one truss machine screw and nut from each side of hopper assembly as shown in figure 4. **Push hopper pivot door down inside lower part of hopper** as you place hopper assembly (both pieces) **inside** upper guide assembly. Replace truss screws and nuts just removed, using the hole shown in figure 4, one on each side. Tighten finger tight only.
- Place the six truss machine screws and nuts found in hardware pack in the remaining holes of hopper assembly, alternating sides of the unit and tightening finger tight only.
- After assembling all eight screws, tighten them securely.

← ATTACHING THE CATCHER BAG

Your chipper-shredder is equipped with a catcher bag to catch the shredded material.

- To attach the bag, place the opening of the bag over the chute deflector so it completely covers the chute opening. Depress the plunger on the draw-

string, and pull on the drawstring until the bag is tight around the chute opening. Release plunger to lock it into position. See figure 5.

OPERATION

KNOW YOUR CHIPPER-SHREDDER

READ THIS OWNER'S MANUAL AND SAFETY RULES BEFORE OPERATING YOUR CHIPPER-SHREDDER. Compare the illustrations with your chipper-shredder to familiarize yourself with the location of various controls and adjustments. Save this manual for future reference.

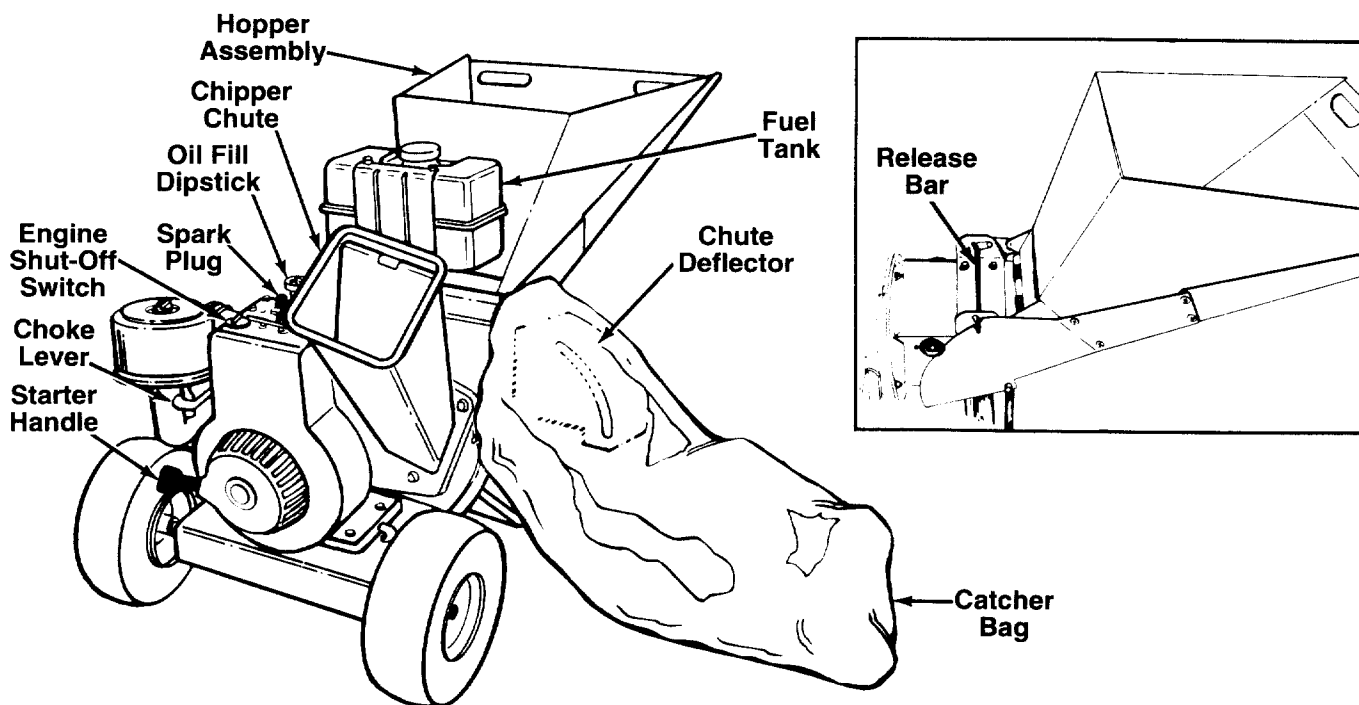

FIGURE 6—Model 247.795861 Shown.

MEETS ANSI SAFETY STANDARDS

Sears chipper-shredders conform to the safety standard B71.6-1982 of the American National Standards Institute.

OPERATING CONTROLS (See figure 6)

RELEASE BAR—Used to release the hopper when raising or lowering.

CHOKE LEVER—Used to enrich the fuel mixture in the carburetor when starting a cold engine.

STARTER HANDLE—Used to manually start the engine.

ENGINE SHUT-OFF SWITCH—Used to stop the engine.

FUEL SHUT-OFF VALVE—Used to stop the flow of fuel into the carburetor (located beneath the fuel tank).

BEFORE USING YOUR CHIPPER-SHREDDER, AGAIN REFER TO THE "SAFETY RULES" AS SHOWN ON PAGE 2 OF THIS MANUAL. ALWAYS BE CAREFUL.



The operation of any chipper-shredder can result in foreign objects being thrown into the eyes, which can result in severe eye damage. Always wear the safety glasses provided with the chipper-shredder or eye shields before chipping or shredding, or while performing any adjustments or repairs. We recommend Wide Vision Safety Mask for over spectacles or standard glasses available at Sears Retail or Catalog Stores.

TO STOP ENGINE

- Move engine shut-off switch to OFF position. See figure 6.
- Disconnect spark plug wire and move away from spark plug to prevent accidental starting while equipment is unattended.
- Close fuel shut-off valve when equipment is not in use to prevent fuel leakage.

HOW TO USE YOUR CHIPPER-SHREDDER

Do not attempt to shred or chip any material other than vegetation found in a normal yard (i.e., branches, leaves, twigs, etc.).



WARNING: THE CHIPPER-SHREDDER DISCHARGES MATERIALS WITH CONSIDERABLE VELOCITY. KEEP AWAY FROM THE AREA AROUND THE CHUTE DEFLECTOR. ALWAYS STOP THE ENGINE AND DISCONNECT THE SPARK PLUG WIRE WHEN REMOVING OR ATTACHING THE BAG WHEN CHANGING CONTAINERS OR WHEN REMOVING THE SHREDDED MATERIAL. WEAR SAFETY GLASSES AND GLOVES WHENEVER USING YOUR CHIPPER-SHREDDER.

The chipper-shredder is designed for three different methods of operation.

- Leaves and small branches up to 1/2" diameter (recommended) or 1" diameter (maximum) can be fed into the hopper assembly when it is in the raised position. See figure 7. If it becomes necessary to push material into the chipper-shredder, use a small diameter stick—NOT YOUR HANDS. The stick should be small enough that it will be ground up if gets into the impeller assembly.



WARNING: DO NOT PUT MATERIAL LARGER THAN 1/2" IN DIAMETER (RECOMMENDED) or 1" DIAMETER (MAXIMUM) INTO THE HOPPER ASSEMBLY. MATERIAL UP TO A MAXIMUM OF 3" IN DIAMETER MATERIAL MAY BE FED INTO THE CHIPPER CHUTE. DO NOT ATTEMPT TO SHRED OR CHIP ANY MATERIAL LARGER THAN 3" IN DIAMETER. PERSONAL INJURY OR DAMAGE TO THE MACHINE COULD RESULT.

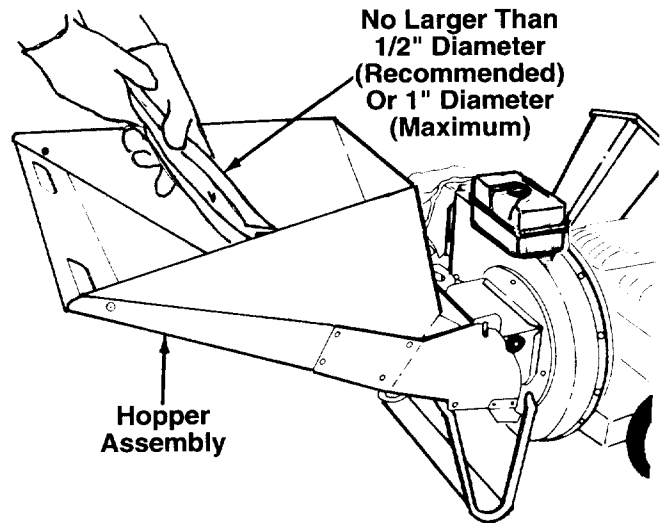

FIGURE 7.

- Leaves and small twigs can be raked into the hopper assembly when the hopper assembly is lowered to the ground. See figure 8. Small branches up to 1/2" diameter (recommended) or 1" diameter (maximum) can also be fed into the hopper assembly in this position. See figure 9.

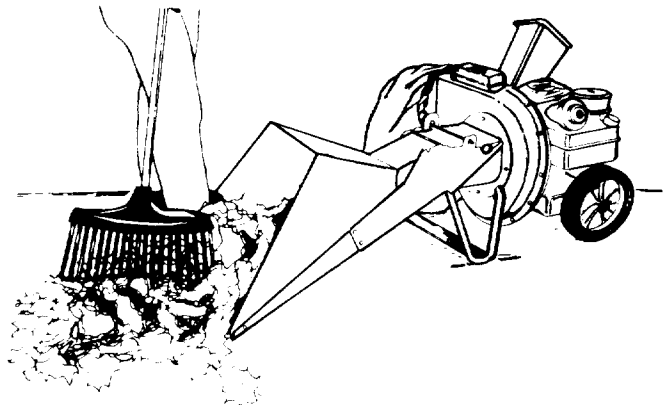

FIGURE 8.

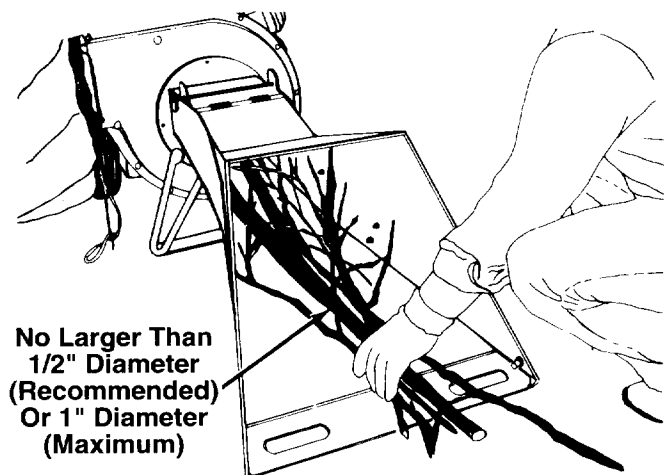

FIGURE 9.

- To lower the hopper assembly, use one hand to grasp the handle at the top of the hopper assembly and lift slightly. Pull up on the release bar, and lower the hopper assembly to the ground. Release the bar. See figure 10.

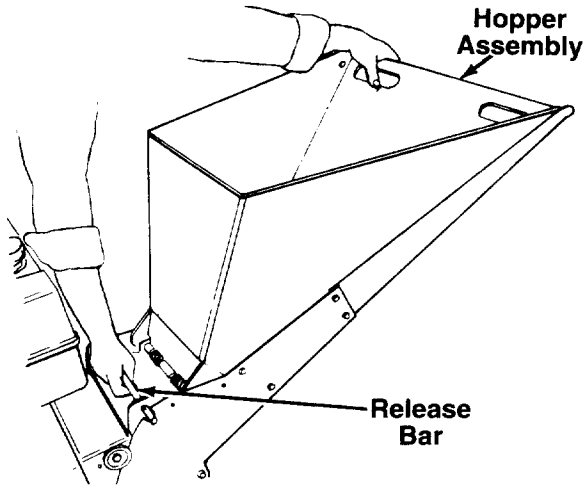

FIGURE 10.

- Bulky material, such as stalks or heavy branches, up to 3" in diameter, should be fed into the chipper chute. See figure 11.

WARNING: MAKE CERTAIN THE CHIPPER CHUTE DOOR IS CLOSED WHEN NOT IN USE.

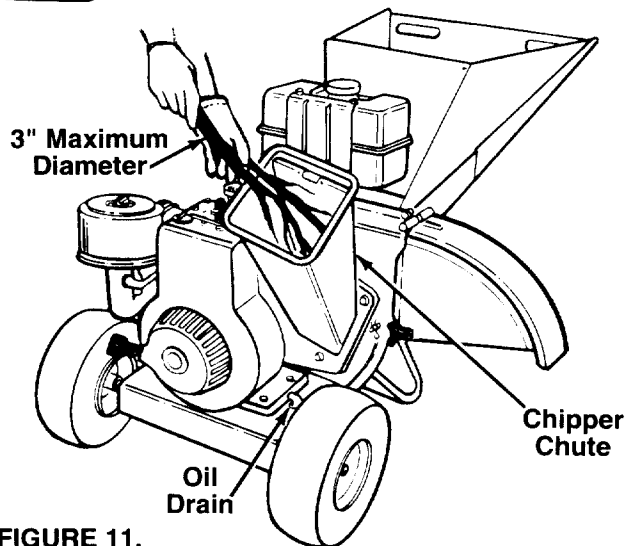

FIGURE 11.

IMPORTANT: There is a flail screen located inside the housing in the discharge area. If the flail screen becomes clogged, remove and clean as instructed in the Service and Adjustments section. For best performance, it is important to keep the shredding blade and the chipper blades sharp. If the composition of the material being discharged changes (becomes stringy, etc.) or if the rate at which the material is discharged slows down considerably, it is likely that the shredding blade and/or chipper blades are dull and need to be sharpened or replaced. Refer to Service and Adjustments section.

GAS AND OIL FILL-UP

OIL

Only use high quality detergent oil rated with API service classification SG. Select the oil's viscosity grade according to your expected operating temperature.

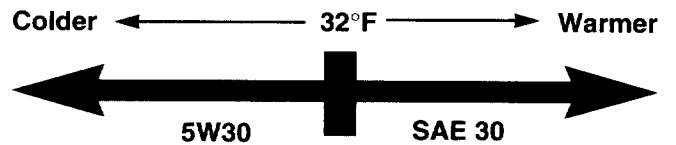

NOTE: Although multi-viscosity oils (5W30, 10W30, etc.) improve starting in cold weather, these multi-viscosity oils will result in increased oil consumption when used above 32°F. Check your oil level more frequently to avoid possible engine damage from running low on oil.

- Fill engine with oil as follows. Remove oil fill dipstick. See figure 12. With chipper-shredder level, use a funnel to fill engine with oil to FULL mark on dipstick. Capacity is approximately 2-3/4 pints. Be careful not to overfill. Tilt chipper-shredder toward the left (from behind the hopper), then re-level. Check oil level. Refill to FULL mark on dipstick if necessary. Replace dipstick and tighten.

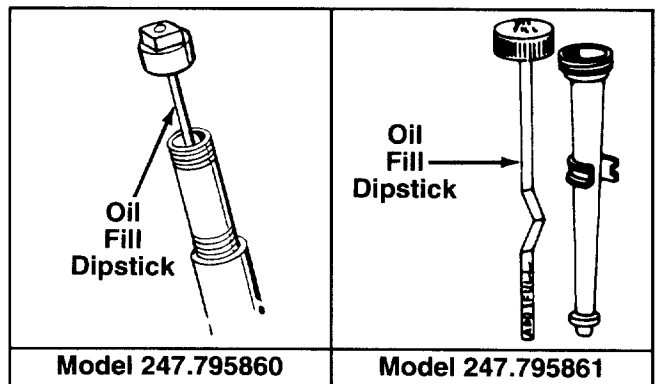

FIGURE 12.

GAS

- Remove fuel cap and fill fuel tank with about 1 gallon of clean, fresh, lead-free grade automotive gasoline. DO NOT use Ethyl or high octane gasoline. Be certain container is clean and free from rust or foreign particles. Never use gasoline that may be stale from long periods of storage in the container. Replace fuel cap.



WARNING: DO NOT FILL CLOSER THAN 1/2 INCH OF TOP OF FUEL TANK TO PREVENT SPILLS AND TO ALLOW FOR FUEL EXPANSION. IF GASOLINE IS ACCIDENTLY SPILLED, MOVE CHIPPER-SHREDDER AWAY FROM AREA OF SPILL. AVOID CREATING ANY SOURCE OF IGNITION UNTIL GASOLINE VAPORS HAVE DISAPPEARED.

Check the fuel level periodically to avoid running out of gasoline while operating the chipper-shredder. If the unit runs out of gas as it is shredding or chipping, it may be necessary to unclog the unit before it can be restarted. Refer to "Removing the Flail Screen" in SERVICE AND ADJUSTMENT section.

WARNING: EXPERIENCE INDICATES THAT ALCOHOL BLENDED FUELS (CALLED GASOHOL OR USING ETHANOL OR METHANOL) CAN ATTRACT MOISTURE WHICH LEADS TO SEPARATION AND FORMATION OF ACIDS DURING STORAGE. ACIDIC GAS CAN DAMAGE THE FUEL SYSTEM OF AN ENGINE WHILE IN STORAGE. TO AVOID ENGINE PROBLEMS, THE FUEL SYSTEM SHOULD BE EMPTIED OR TREATED WITH FUEL STABILIZER BEFORE STORAGE FOR 30 DAYS OR LONGER. USE FRESH FUEL NEXT SEASON. SEE "STORAGE" SECTION FOR ADDITIONAL INFORMATION.

NEVER USE ENGINE OR CARBURETOR CLEANER PRODUCTS IN THE FUEL TANK OR PERMANENT DAMAGE MAY OCCUR.

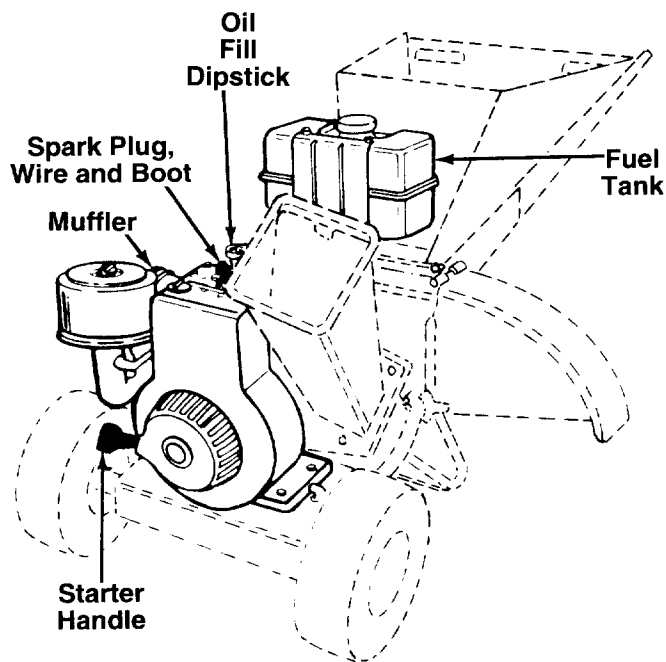

FIGURE 13.

TO START ENGINE



WARNING: BE SURE NO ONE OTHER THAN THE OPERATOR IS STANDING NEAR THE CHIPPER-SHREDDER WHILE STARTING OR OPERATING. DO NOT OPERATE THIS CHIPPER-SHREDDER UNLESS THE CHUTE DEFLECTOR HAS BEEN PROPERLY INSTALLED AND IS SECURED WITH THE HAND KNOBS.

- Attach spark plug wire and rubber boot to spark plug if necessary. See figure 13.
- Open fuel shut-off valve by turning in direction of arrow several turns. See figure 14.
- Move choke lever down to CHOKE position.
- Place the engine shut-off switch in ON position. See figure 14.
- Grasp starter handle (see figure 13) and pull rope out slowly until engine reaches start of compression cycle (rope will pull slightly harder at this point). Let the rope rewind slowly.

NOTE: A noise will be heard when finding the start of the compression cycle. This noise is caused by the flails and fingers which are part of the shredding mechanism falling into place, and should be expected. In addition, the flails and fingers will be noisy after the engine is started, until the impeller reaches full speed.

- Pull rope with a rapid, continuous, full arm stroke. Keep a firm grip on start handle. Let rope rewind slowly. Do not let starter handle snap back against starter.
- Repeat preceding two instructions until engine fires. When engine starts, move choke lever on engine halfway between CHOKE and RUN.

NOTE: If engine does not fire after three attempts, move choke lever halfway between CHOKE and RUN position and try again. See figure 14.

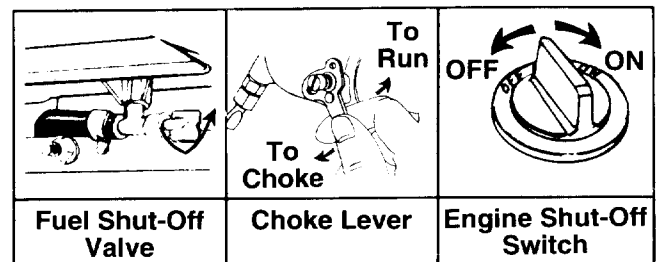

FIGURE 14.

TO STOP ENGINE

- Move engine shut-off switch to OFF position. See figure 14.
- Disconnect spark plug wire and move away from spark plug to prevent accidental starting while equipment is unattended.
- Close fuel shut-off valve when equipment is not in use to prevent fuel leakage.

CUSTOMER RESPONSIBILITIES

MAINTENANCE SCHEDULE FILL IN DATES AS YOU COMPLETE REGULAR SERVICE								SERVICE DATES							
		BEFORE EACH USE	AFTER EACH USE	FIRST FIVE HOURS	EVERY 25 HOURS	EVERY 50 HOURS	BEFORE STORAGE								
PRODUCT	Oil Pivot Points						✓								
	Clean Shredder		✓				✓								
ENGINE	Check Engine Oil	✓													
	Change Engine Oil			✓	✓										
	Service Air Cleaner				✓										
	Clean Engine Cylinder				✓		✓								
	Spark Plug				✓		✓								
	Muffler					✓									

✓ CHECK

GENERAL RECOMMENDATIONS



WARNING: ALWAYS STOP THE ENGINE AND DISCONNECT THE SPARK PLUG WIRE BEFORE PERFORMING ANY MAINTENANCE OR ADJUSTMENTS.

- Periodically check all fasteners and be sure they are tight.
- Follow the Maintenance Schedule above.

CHIPPER-SHREDDER LUBRICATION

Lubricate the pivot points on the release bar, hopper assembly, chute deflector and chipper chute once a season using a light oil.

ENGINE ENGINE OIL

Only use high quality detergent oil rated with API service classification SG. Select the oil's viscosity grade according to your expected operating temperature.

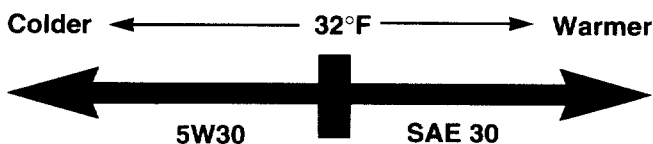

NOTE: Although multi-viscosity oils (SE30, 10W30, etc.) improve starting in cold weather, these multi-viscosity oils will result in increased oil consumption when used above 32°F. Check your oil level more frequently to avoid possible engine damage from running low on oil.

Your four-cycle engine will normally consume some oil—therefore, check engine oil level regularly approximately every five hours of operation and before each usage. Stop engine and wait several minutes before checking oil level. With engine level, the oil must be to FULL mark on dipstick (refer to figure 12). Change engine oil after the first five hours of operation, and every twenty-five hours thereafter.

To Drain Oil:

- Drain oil while engine is warm.
 - a. Remove oil drain plug. Refer to figure 11. Catch oil in a suitable container.
 - b. When engine is drained of all oil, replace drain plug securely.
- Refill with fresh oil. Refer to GAS AND OIL FILL-UP section.
- Replace dipstick.

AIR CLEANER

The air cleaner prevents damaging dirt, dust, etc., from entering the carburetor and being forced into the engine and is important to engine life and performance.

Never run your engine without air cleaner completely assembled.

To Service Air Cleaner:

Service pre-cleaner after every 25 hours of use, or at least once a season. Service cartridge every 100 hours of use, or at least once a season. Service pre-cleaner and cartridge more often under dusty conditions.

- Remove wing nut and cover.
- To service foam pre-cleaner: Remove pre-cleaner by sliding it off the cartridge. Wash in liquid detergent and water. Squeeze dry in a clean cloth. Saturate in engine oil. Squeeze in a clean, absorbent cloth to remove all excess oil. If pre-cleaner is very dirty, replace it.
- To service cartridge: Remove cartridge by removing wing nut and lifting off cup and cartridge. Clean by tapping gently on a flat surface. If very dirty, replace. Do not oil cartridge.

NOTE: Do not use petroleum solvents (e.g. kerosene) or pressurized air to clean cartridge. They will cause cartridge to deteriorate.

- Reinstall cartridge, cup, pre-cleaner and cover.
- Fasten wing nuts securely.

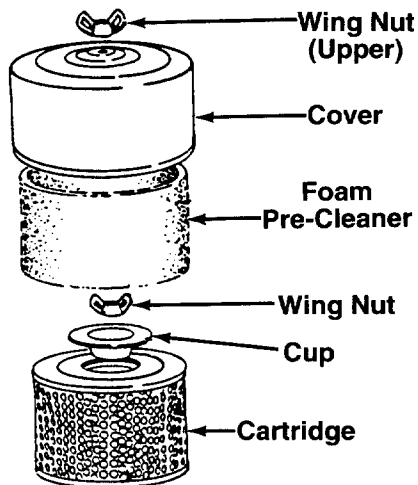

FIGURE 15.

FUEL FILTER

Your engine is equipped with a replaceable in-line fuel filter. Replace the fuel filter every season. See figure 16. Refer to engine parts list for correct replacement filter.

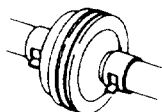

FIGURE 16.

CLEAN ENGINE

Clean engine periodically. Remove dirt and debris with a cloth or brush. Cleaning with a forceful spray of water is not recommended as water could contaminate the fuel system.

Yearly or every 25 hours, whichever occurs first, remove the blower housing and clean the areas shown in figure 17 to avoid overspeeding, overheating and engine damage. Clean more often if necessary.



WARNING: PERIODICALLY CLEAN MUFFLER AREA TO REMOVE ALL GRASS, DIRT AND COMBUSTIBLE DEBRIS.

LEANING

The chipper-shredder may be cleaned by running water from a hose through the hopper assembly and chipper chute with the engine running. Allow the chipper-shredder to dry thoroughly.

- Wash the bag periodically with water. Allow to dry thoroughly in the shade. Do not use heat.

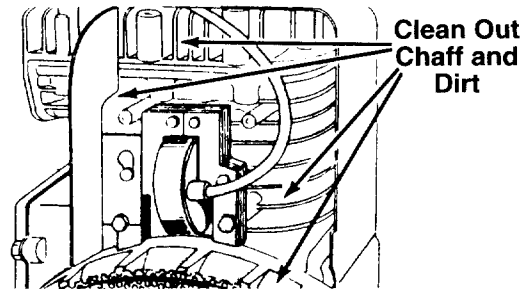

FIGURE 17.

SPARK PLUG

The spark plug should be cleaned and the gap reset to .030" at least once a season or every 50 hours of operation. See figure 18. Spark plug replacement is recommended at the start of each season. Refer to engine parts list for correct spark plug type.

NOTE: Do not sandblast spark plug. Spark plug should be cleaned by scraping or wire brushing and washing with a commercial solvent.

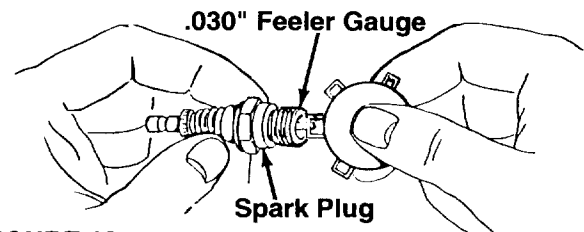

FIGURE 18.

MUFFLER

Do not operate the chipper-shredder without a muffler or tamper with the exhaust system. Damaged mufflers or spark arresters could create a fire hazard. Inspect periodically, and replace if necessary. If your engine is equipped with a spark arrester screen assembly, remove every 50 hours for cleaning and inspection. Replace if damaged.

STORAGE

Prepare your chipper-shredder for storage at the end of the season or if the unit will not be used for 30 days or more.



WARNING: NEVER STORE MACHINE WITH FUEL IN THE FUEL TANK INSIDE OF BUILDING WHERE FUMES MAY REACH AN OPEN FLAME OR SPARK, OR WHERE IGNITION SOURCES ARE PRESENT SUCH AS HOT WATER AND SPACE HEATERS, FURNACES, CLOTHES DRYERS, STOVES, ELECTRIC MOTORS, ETC.

NOTE: A yearly check-up by your local Sears Service Center is a good way to make certain your chipper-shredder will provide maximum performance for the next season.

CHIPPER-SHREDDER

- Clean the chipper-shredder thoroughly.
- Wipe unit with an oiled rag to prevent rust (use a light oil or silicone).

ENGINE

IMPORTANT: IT IS IMPORTANT TO PREVENT GUM DEPOSITS FROM FORMING IN ESSENTIAL FUEL SYSTEM PARTS SUCH AS CARBURETOR, FUEL FILTER, FUEL HOSE, OR TANK DURING STORAGE. ALSO, EXPERIENCE INDICATES THAT ALCOHOL BLENDED FUELS (CALLED GASOHOL OR USING ETHANOL OR METHANOL) CAN ATTRACT MOISTURE WHICH LEADS TO SEPARATION AND FORMATION OF ACIDS DURING STORAGE. ACIDIC GAS CAN DAMAGE THE FUEL SYSTEM OF AN ENGINE WHILE IN STORAGE.

- Drain the fuel tank.
- Start the engine and let it run until the fuel lines and carburetor are empty.
- Never use engine or carburetor cleaner products in the fuel tank or permanent damage may occur.
- Use fresh fuel next season.

NOTE: Fuel stabilizer is an acceptable alternative in minimizing the formation of fuel gum deposits during storage. Add stabilizer to gasoline in fuel tank or storage container. Always follow the mix ratio found on stabilizer container. Run engine at least 10 minutes after adding stabilizer to allow the stabilizer to reach the carburetor. Do not drain the gas tank and carburetor if using fuel stabilizer.

- Drain all the oil from the crankcase (this should be done after the engine has been operated and is still warm) and refill the crankcase with fresh oil.
- If you have drained the fuel tank, protect the inside of the engine as follows. Remove spark plug, pour approximately 1/2 ounce (approximately one tablespoon) of engine oil into cylinder and crank slowly to distribute oil. Replace spark plug.

OTHER

- Do not store gasoline from one season to another.
- Replace your gasoline can if your can starts to rust. Rust and/or dirt in your gasoline will cause problems.
- Store unit in a clean, dry area. Do not store next to corrosive materials, such as fertilizer.

NOTE: If storing in an unventilated or metal storage shed, be certain to rustproof the equipment by coating with a light oil or silicone.

SERVICE & ADJUSTMENT



WARNING: ALWAYS STOP ENGINE AND DISCONNECT SPARK PLUG WIRE AND MOVE IT AWAY FROM SPARK PLUG BEFORE PERFORMING ANY ADJUSTMENTS OR REPAIRS.

REMOVING THE FLAIL SCREEN

If the discharge area becomes clogged, remove the flail screen and clean area as follows.

- Stop the engine, make certain the chipper-shredder has come to a complete stop and disconnect spark plug wire from the spark plug before unclogging the chute.

- Loosen the two hand knobs on each side of the chute deflector. Lift the chute deflector up, and tie it out of the way.
- Remove two hairpin clips from the clevis pins which extend through the housing. Remove the clevis pins. Lift the flail screen from inside the housing. See figure 19.
- Clean the screen by scraping or washing with water. Reinstall the screen.

NOTE: Be certain to reassemble the flail screen with the curved side down as shown in figure 19.

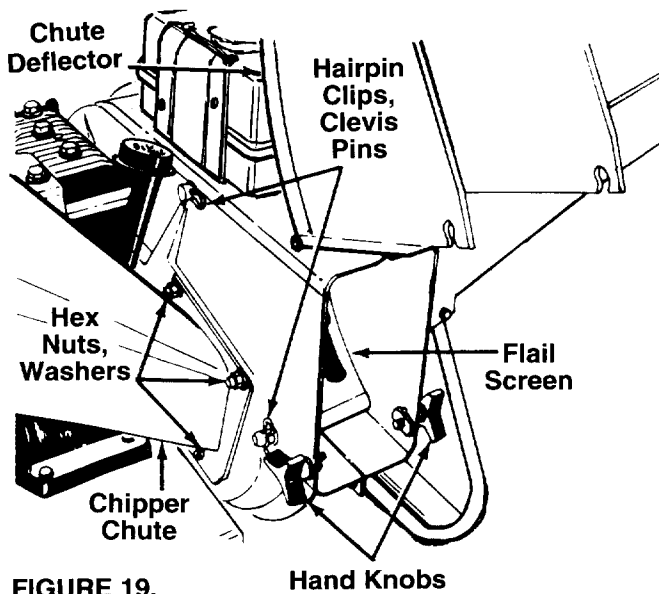

FIGURE 19.

SHARPENING OR REPLACING THE BLADES

CHIPPER BLADES

- Disconnect spark plug wire and move it away from spark plug.
- Remove the flail screen as instructed in previous section.
- Remove the chipper chute by removing three hex nuts and washers. A 1/2" wrench is required. See figure 19.

NOTE: When reassembling, the cupped washer goes on the bottom of the chipper chute with the cupped side against the chute.

- Rotate the impeller assembly by hand until you locate one of the chipper blades in the chipper chute opening. Remove the blade, using a 3/16" allen wrench on the outside of the blade and 1/2" wrench on the impeller assembly (inside the housing). See figure 20.
- Remove the other blade in the same manner.

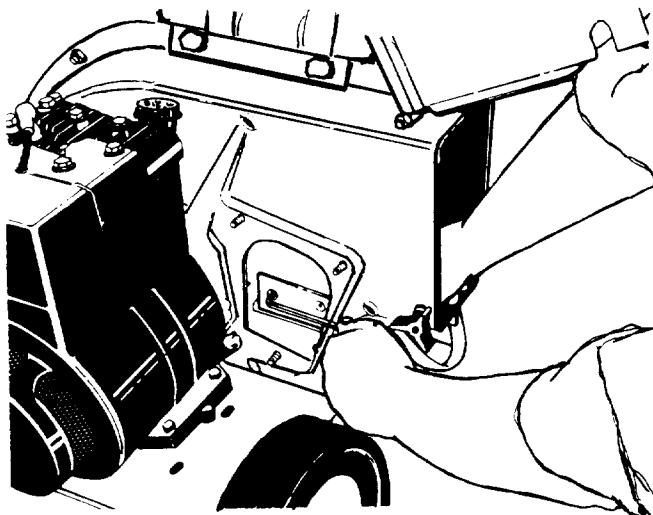

FIGURE 20.

Replace or sharpen blades. If sharpening, make certain to remove an equal amount from each blade. Reassemble in reverse order.

Make certain blades are reassembled with the sharp edge facing the direction shown in figure 19 (sharp edge is assembled toward the slotted opening in the impeller assembly).

SHREDDING BLADE

The shredding blade may be removed for sharpening or replacement as follows.

- Disconnect spark plug wire and move it away from spark plug.
- Lower the hopper assembly. Block up the housing. See figure 21.
- Remove the six hex lock nuts and lock washers from the housing weld bolts using a 1/2" wrench. Separate the chipper-shredder into two halves.
- Remove the back-up plate.

NOTE: When reassembling, make certain the opening on the back-up plate is toward the bottom of the unit. The back-up plate may be reversed to provide a new cutting edge.

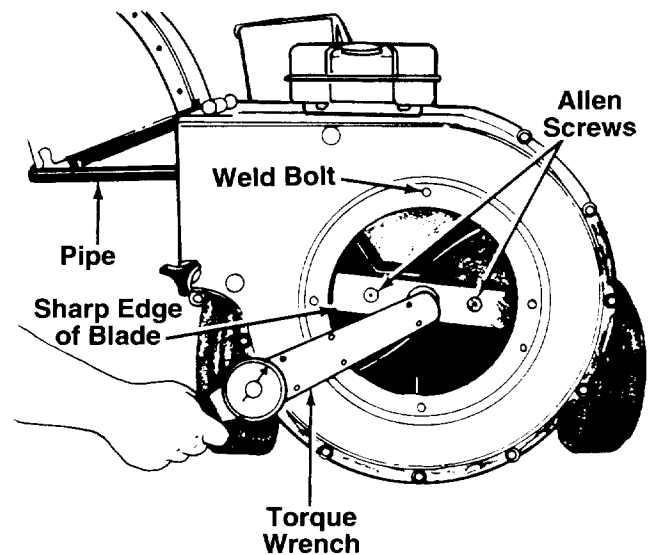

FIGURE 21.

- Loosen the two hand knobs and cupped washers which secure the chute deflector, and raise the chute deflector.
- Insert a 1/2" or 3/4" diameter pipe through the flail screen into the impeller to keep it from turning, or remove the flail screen and insert a piece of wood (2 x 4) into the chute opening.
- Remove the two outside screws on the blade, using a 3/16" allen wrench and a 1/2" wrench.
- Remove the blade by removing the center bolt, lock washer and flat washer.

NOTE: Use caution when removing the blade to avoid contacting the weld bolts on the housing.

- When sharpening the blade, follow the original angle of grind as a guide. It is extremely important that each cutting edge receives an equal amount of grinding to prevent an unbalanced blade. An unbalanced blade will cause excessive vibration when rotating at high speeds and may cause damage to the unit.
- The blade can be tested for balance by balancing it on a round shaft screwdriver or nail. Remove metal from the heavy side until it is balanced evenly. See figure 22.

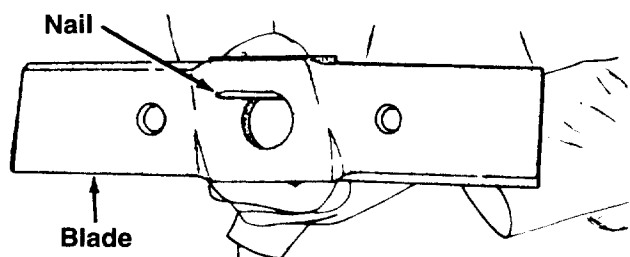

FIGURE 22.

- When reassembling the blade, tighten to between 550 and 650 inch pounds, or lacking torque wrench, tighten securely.

FLAILS

The flails, located inside the housing, may be reversed when they become dull. It is suggested that this procedure be performed by your nearest Sears Service Department.

CARBURETOR ADJUSTMENT



WARNING: IF ANY ADJUSTMENTS ARE MADE TO THE ENGINE WHILE THE ENGINE IS RUNNING (E.G. CARBURETOR), KEEP CLEAR OF ALL MOVING PARTS. BE CAREFUL OF HEATED SURFACES AND MUFFLER.

Minor carburetor adjustment may be required to compensate for differences in fuel, temperature, altitude or load.

NOTE: A DIRTY AIR CLEANER WILL CAUSE ENGINE TO RUN ROUGH. BE CERTAIN AIR CLEANER IS CLEAN AND ATTACHED TO THE CARBURETOR BEFORE ADJUSTING CARBURETOR. DO NOT MAKE UNNECESSARY ADJUSTMENTS. FACTORY SETTINGS ARE SATISFACTORY FOR MOST APPLICATIONS AND CONDITIONS.

Never attempt to change maximum engine speed. It is pre-set at the factory and should be changed only by a qualified service technician who has the necessary equipment.

The carburetor may need re-adjusting if engine lacks power or does not idle properly. If adjustments are needed, proceed as follows.

- Close needle valve (see figure 23) clockwise (↻) finger tight only. Forcing may cause damage. Then open 1-1/2 turns counterclockwise (↺).
- Start engine and allow to warm for five minutes.
- Close needle valve clockwise (↻) until engine starts to lose speed (lean mixture). Then slowly open needle valve counterclockwise (↺) until engine JUST BEGINS to run unevenly. This mixture should be rich enough for best performance under load.
- Rotate throttle counterclockwise (↺) and hold against throttle stop. If engine idles, no further adjustment is necessary. If engine idles too fast, turn idle speed adjusting screw counterclockwise (↺) until slower speed is obtained. If engine dies, turn idle speed adjusting screw 1/4 turn clockwise (↻). Place throttle control in FAST position and restart engine.

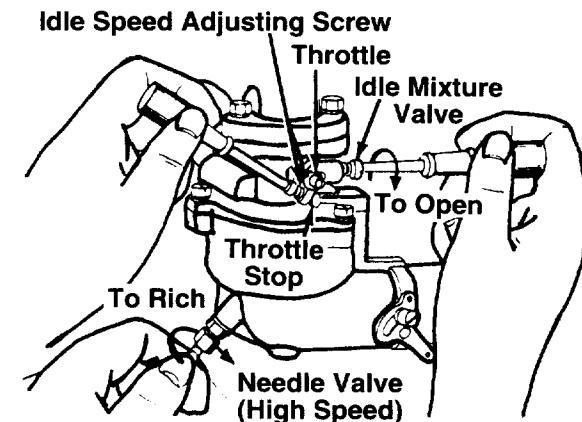

FIGURE 23.

ENGINE SPEED

Your engine speed has been factory set. Do not attempt to increase engine speed or it may result in personal injury. If you believe the engine is running too fast or too slow, take your chipper-shredder to the nearest SEARS Service Center for repair and adjustment.

TROUBLE SHOOTING

PROBLEM	POSSIBLE CAUSE(S)	CORRECTIVE ACTION
Engine fails to start	<ul style="list-style-type: none"> ● Fuel shut-off valve closed. ● Fuel tank empty, or stale fuel. ● Spark plug wire disconnected. ● Faulty spark plug. 	<ul style="list-style-type: none"> ● Open fuel shut-off valve. ● Fill tank with clean, fresh fuel. ● Connect wire to spark plug. ● Clean, adjust gap or replace.
Loss of power; operation erratic	<ul style="list-style-type: none"> ● Spark plug wire loose. ● Unit running on CHOKE. ● Blocked fuel line or stale fuel. ● Water or dirt in fuel system. ● Carburetor out of adjustment. ● Dirty air cleaner. 	<ul style="list-style-type: none"> ● Connect and tighten spark plug wire. ● Move choke lever to OFF position. ● Clean fuel line; fill tank with clean fresh gasoline. ● Disconnect fuel line at carburetor to drain fuel tank. Refill with fresh fuel. ● Adjust carburetor or contact your SEARS Service Center. ● Service air cleaner. See Customer Responsibilities section of this manual.
Engine overheats	<ul style="list-style-type: none"> ● Carburetor not adjusted properly. ● Engine oil level low. 	<ul style="list-style-type: none"> ● Contact your SEARS Service Center. ● Fill crankcase with proper oil.
Too much vibration	<ul style="list-style-type: none"> ● Loose parts or damaged impeller. 	<ul style="list-style-type: none"> ● Stop engine immediately and disconnect spark plug wire. Tighten all bolts and nuts. Make all necessary repairs. If vibration continues, have unit serviced by a SEARS Service Center.
Unit does not discharge	<ul style="list-style-type: none"> ● Discharge chute clogged. ● Foreign object lodged in impeller. 	<ul style="list-style-type: none"> ● Stop engine immediately and disconnect spark plug wire. Clean flail screen and inside of blower housing. See Service/Adjustments section of this manual. ● Stop engine immediately and disconnect spark plug wire. Remove lodged object.
Rate of discharge slows considerably or composition of discharged material changes	<ul style="list-style-type: none"> ● Shredding blade and/or chipper blades dull. 	<ul style="list-style-type: none"> ● Sharpen or replace shredding and chipper blades.

NOTE: For repairs beyond the minor adjustments listed above, please contact your nearest SEARS Service Center.

HOW TO ORDER REPLACEMENT PARTS

Each chipper-shredder has its own model number. Each engine has its own model number.

The model number for your chipper-shredder will be found on a label attached to the frame.

The model number for the engine will be found on the blower housing of the engine.

All parts listed herein may be ordered through Sears, Roebuck and Co. Service Centers and most Retail Stores.

WHEN ORDERING REPAIR PARTS, ALWAYS GIVE THE FOLLOWING INFORMATION:

***PRODUCT - "8 H.P. Chipper-Shredder"**

***MODEL NUMBER - 247.795860
247.795861**

***ENGINE MODEL NO. - 190412-6143-01
190432-6117-01**

***PART NUMBER**

***PART DESCRIPTION**

Your Sears merchandise has added value when you consider that Sears has service units nationwide staffed with Sears trained technicians...professional technicians specifically trained on Sears products, having the parts, tools and the equipment to insure that we meet our pledge to you..."we service what we sell."

**SEARS CRAFTSMAN 8 H.P. CHIPPER-SHREDDER MODEL NOS. 247.795860
247.795861**

Repair Parts

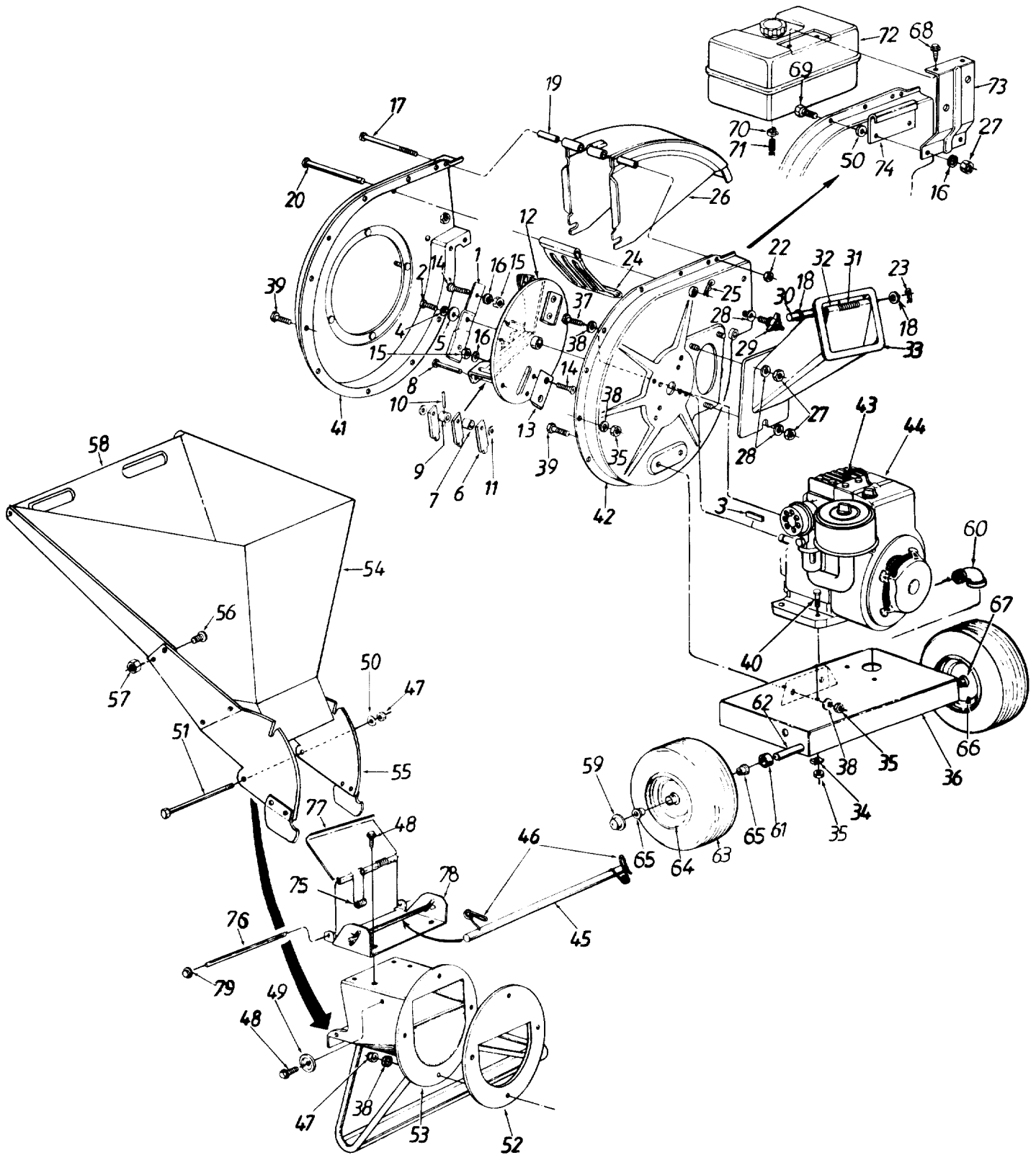

**SEARS CRAFTSMAN 8 H.P. CHIPPER-SHREDDER MODEL NOS. 247.795860
247.795861**

Repair Parts

KEY NO.	PART NO.	DESCRIPTION	KEY NO.	PART NO.	DESCRIPTION
1	742-0571	Blade	41	681-0004	Flail Housing Ass'y.—L.H.
2	710-0818	Hex Patch Bolt 3/8-24 x 2" Lg. (Gr. 8) (247.795860)	42	781-0474A	Flail Housing Ass'y.—R.H.
	710-1254	Hex Patch Bolt 3/8-24 x 2.25" Lg. (Gr. 8) (247.795861)	43	735-0639	Spark Plug Boot
3	714-0114	Sq. Key 1/4 x 2.0" Lg. (247.795860)	44	190412-6143-01	Engine—B&S190412-6143-01 (247.795860)
4	736-0217	L-Wash. 3/8" I.D. H.D.		190432-6117-01	Engine—B&S 190432-6117-01 (247.795861)
5	736-0247	Fl-Wash. .406" I.D. x 1.25" O.D. Hdn.	45	747-0531A	Release Bar
6	11459B	Flail	46	742-0546	Torsion Spring 1.06" Lg.
7	711-0564	Flail Spacer	47	712-0429	Elastic Lock Nut 5/16-18 Thd.
8	711-0833A	Clevis Pin .496" Dia.	48	710-0601	Hex Wash. Hd. Self-Tap Scr. 5/16-18 x .75" Lg.
9	711-0834	Flail Spacer w/.160" Dia. Hole	49	11480	Stop Washer
10	715-0249	Spring Roll Pin 1.12" Lg.	50	736-0264	Fl-Wash. 5/16" I.D.
11	736-0192	Fl-Wash. .531" I.D. x .94" O.D.	51	710-0542	Hex Bolt 5/16-18 x 8.38" Lg.
12	681-0002	Impeller Ass'y. Comp. (247.795860)†	52	781-0487B	Back-Up Plate
	681-0030	Impeller Ass'y. Comp. (247.795861)†	53	16522B	Inlet Guide Ass'y.
13	781-0490	Chipper Blade	54	781-0494	Pivot Hopper Hood
14	710-1054	Flat Hd. Scr. 5/16-24 x .75" Lg.	55	16524B	Upper Guide Ass'y.
15	712-0411	Hex Top L-Nut 5/16-24 (Gr. 5)	56	710-0286	Truss Mach. Scr. 1/4-20 x .5" Lg.
16	736-0119	L-Wash. 5/16" I.D.*	57	712-0107	Hex L-Nut 1/4-20 Thd.
17	710-0825	Hex Bolt 1/4-20 x 3.75" Lg.*	58	11461B	Upper Leaf Ramp Section
18	736-0142	Fl-Wash. .281" I.D. x .50" O.D.	59	726-0214	Push Cap 5/8" Dia. Rod
19	750-0793	Chute Hinge Spacer 1.66" Lg.	60	737-0125	Drain Elbow
20	711-0835	Clevis Pin .5" Dia. x 4.62" Lg.	61	750-0786	Spacer .64" I.D. x .38" Lg.
22	712-0291	Hex Ctr. L-Nut 1/4-20 Thd.	62	738-0813	Shredder Axle
23	714-3010	Cotter Pin	63	734-1597	Wheel Ass'y. Comp.
24	781-0457	Shredder Screen		734-1598	Tire Only
25	714-0149B	Internal Cotter Pin 3/8" Dia.	64	734-1455	Rim Only
26	781-0480	Chute Deflector Ass'y.	65	741-0487	Flange Bearing .632" I.D.
27	712-3010	Hex Nut 5/16-18 Thd. (Gr. 5)	66	734-0255	Air Valve
28	736-0242	Bell-Wash. .345" I.D. x .88"	67	737-0280	Grease Fitting
29	720-0170	Hand Knob	68	710-0895	Hex Hi-Low Scr. 1/4 x .75"
30	747-0744A	Chipper Door Rod	69	710-3038	Hex Bolt 5/16-18 x .88" Lg.
31	732-0542	Torsion Spring 1.14" Lg.	70	726-0205	Hose Clamp
32	781-0489	Chipper Door	71	751-0535-7	Fuel Line—7 in.
33	781-0475	Chipper Chute Ass'y.	72	751-0570	Fuel Tank Ass'y. Comp.
34	736-0170	Spec. L-Wash. 5/16" I.D.	73	781-0497	Fuel Tank Mtg. Brkt.
35	712-3010	Hex Nut 5/16-18 Thd. (Gr. 5)	74	781-0498	Fuel Tank Support Brkt.
36	781-0459A	Shredder Frame	75	732-0629	Torsion Spring
37	710-0157	Hex Bolt 5/16-24 x .75" Lg.	76	747-0747	Hopper Door Rod
38	736-0119	L-Wash. 5/16" I.D.*	77	781-0492	Hopper—Pivot Door
39	710-3008	Hex Bolt 5/16-18 x .75" Lg. (Gr. 5)	78	781-0493	Hopper Lockout Brkt.
40	710-0380	Hex Bolt 5/16-18 x 1.75" Lg.*	79	726-0106	Cap Speed Nut 1/4" Rod
			—	764-0199A	Bag (Not Shown)
			—	723-0400	Safety Glasses (Not Shown)
			—	770-8175H	Owner's Manual

†Incl. Ref. 1, 6, 7, 8, 9, 10, 11, 12, 13, 14

*Common Hardware—May Be Purchased Locally.

NOTE: Specifications subject to change without notice or obligation.

**BRIGGS AND STRATTON 8 H.P. ENGINE MODEL NOS. 190412-6143-01
190432-6117-01**

Repair Parts

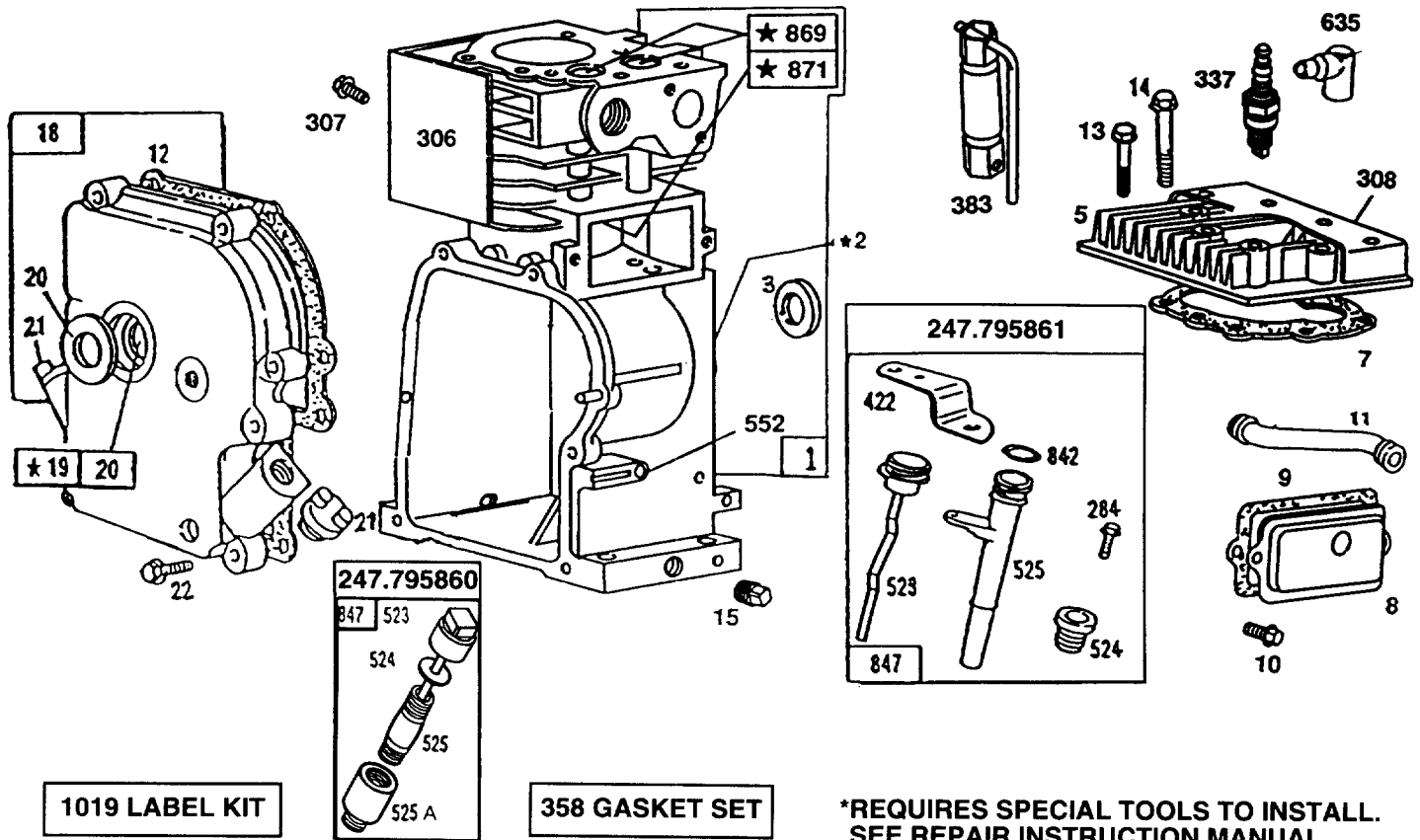

1019 LABEL KIT

358 GASKET SET

***REQUIRES SPECIAL TOOLS TO INSTALL.
SEE REPAIR INSTRUCTION MANUAL.**

REF. NO.	PART NO.	DESCRIPTION	REF. NO.	PART NO.	DESCRIPTION
1	495631	Cylinder Assembly	307	93949	Screw-Cyl. Shield
2	495657	Bushing-Cyl.	308	222636	Cover-Cylinder Head
3	391086	Seal-Oil	337	802592	Plug-Spark
5	214015	Head-Cylinder	358	299577	Gasket Set
7	272163	Gasket-Cylinder Hd.	383	89838	Wrench-Spark Plug
8	390321	Breather Assembly	422	223375	Bracket-Oil Fill
9	27803	Gasket-Valve Cover	523	295357	Cap Oil Filler (247.795860)
10	94621	Screw-Sem	396987	396987	Cap and Dipstick-Oil Filler (247.795861)
11	280267	Tube-Breather	524	65304	Gasket-Oil Filler (247.795860)
12	271701	Gasket-Crankcase Cover (1/64" Thick)	68838	68838	Seal-Filler Tube (247.795861)
	27876	Gasket-Crankcase Cover (.005" Thick)	525	91258	Nipple-Oil Filler (247.795860)
	27877	Gasket-Crankcase Cover (.009" Thick)	280220	280220	Tube-Oil Fill (247.795861)
13	94565	Screw-Cylinder Head (3-9/16" Long)	525A	394884	Adapter-Oil Filler (247.795860)
14	93723	Screw-Cyl. Hd. (3" Long) (1)	552	491893	Bushing-Gov. Crank
15	94239	Plug-Oil Drain	635	66538	Elbow-Spark Plug
		Note: 94613 Plug-Pipe (Flush)	842	271170	Seal-Tube
18	299175	Cover Ass'y.-Crkscse. (247.795860)	847	493955	Dipstick and Tube Ass'y. (247.795860)
	399898	Cover Ass'y.-Crkscse. (247.795861)	399901	399901	Dipstick and Tube Assy. (247.795861)
19	295964	Bushing-Crkscse.	869	211661	Seat-Int. and Ex. Vlv.
20	391086	Seal-Oil	871	231218	Guide-Ex. and Int. Vlv.
21	66768	Plug-Oil Filler			Note: For Options See Repair Manual.
22	93585	Screw-Crkscse. Cover	1019	491181	Label Kit
306	223374	Shield-Cylinder			

Assemblies include all parts shown in frames.

**BRIGGS AND STRATTON 8 H.P. ENGINE MODEL NOS. 190412-6143-01
190432-6117-01**

Repair Parts

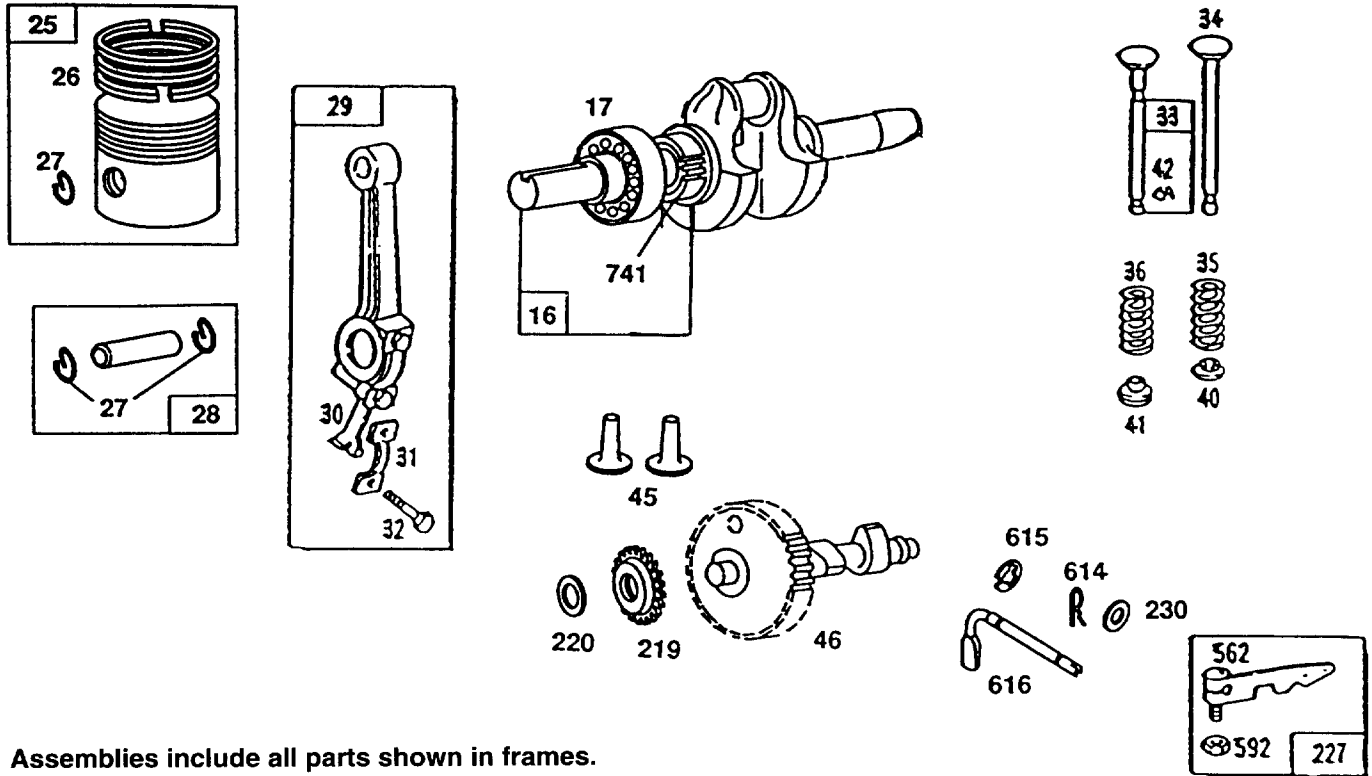

Assemblies include all parts shown in frames.

REF. NO.	PART NO.	DESCRIPTION	REF. NO.	PART NO.	DESCRIPTION
16	495884 495866	Crankshaft (247.795860) Crankshaft (247.795861) Note: Order 94388 Key For Timing Gear Retaining Device.	31	222114	Lock-Conn. Rod Screw (247.795861)
17	29530	Bearing-Ball (247.795860)	32	94670 92659	Screw-Conn. Rod (247.795860) Screw-Conn. Rod (247.795861)
25	391673 391674 391675 391676	Piston Assy. (Std.) Piston Assembly (.010" O.S.) Piston Assembly (.020" O.S.) Piston Assembly (.030" O.S.)	33	390419	Valve-Exhaust
26	391669 391670 391671 391672	Ring Set-Piston (Std.) Ring Set-Piston (.010" O.S.) Ring Set-Piston (.020" O.S.) Ring Set-Piston (.030" O.S.)	34	261055	Valve-Intake
27	68546	Lock-Piston Pin	35	65906	Spring-Intake Valve
28	295840 295841	Pin Assembly-Piston (Standard) Pin Assembly- Piston (.005" O.S.)	36	26828	Spring-Exhaust Valve
29	390401	Rod Assembly- Connecting Note: For Connecting Rod With .020" Undersize Crankpin Bore- Order Part No. 390773.	40	221596	Retainer-Intake Valve
30	222113	Dipper-Conn. Rod	41	292260	Rotocoil-Ex. Valve
			42	93630	Retainer-Exhaust Valve Rotocoil (2)
			45	260933	Tappet-Valve
			46	211689	Gear-Cam
			219	494845	Gear-Governor
			220	221551	Washer-Thrust
			227	391965	Lever Assy.-Gov.
			230	222450	Washer-Gov. Crank
			562	92613	Bolt-Governor Lever
			592	231082	Nut-Hex.
			614	93306	Cotter-Pin
			615	93307	Retainer-E#Ring
			616	231057	Crank-Governor
			741	262479	Gear-Timing

**BRIGGS AND STRATTON 8 H.P. ENGINE MODEL NOS. 190412-6143-01
190432-6117-01**

Repair Parts

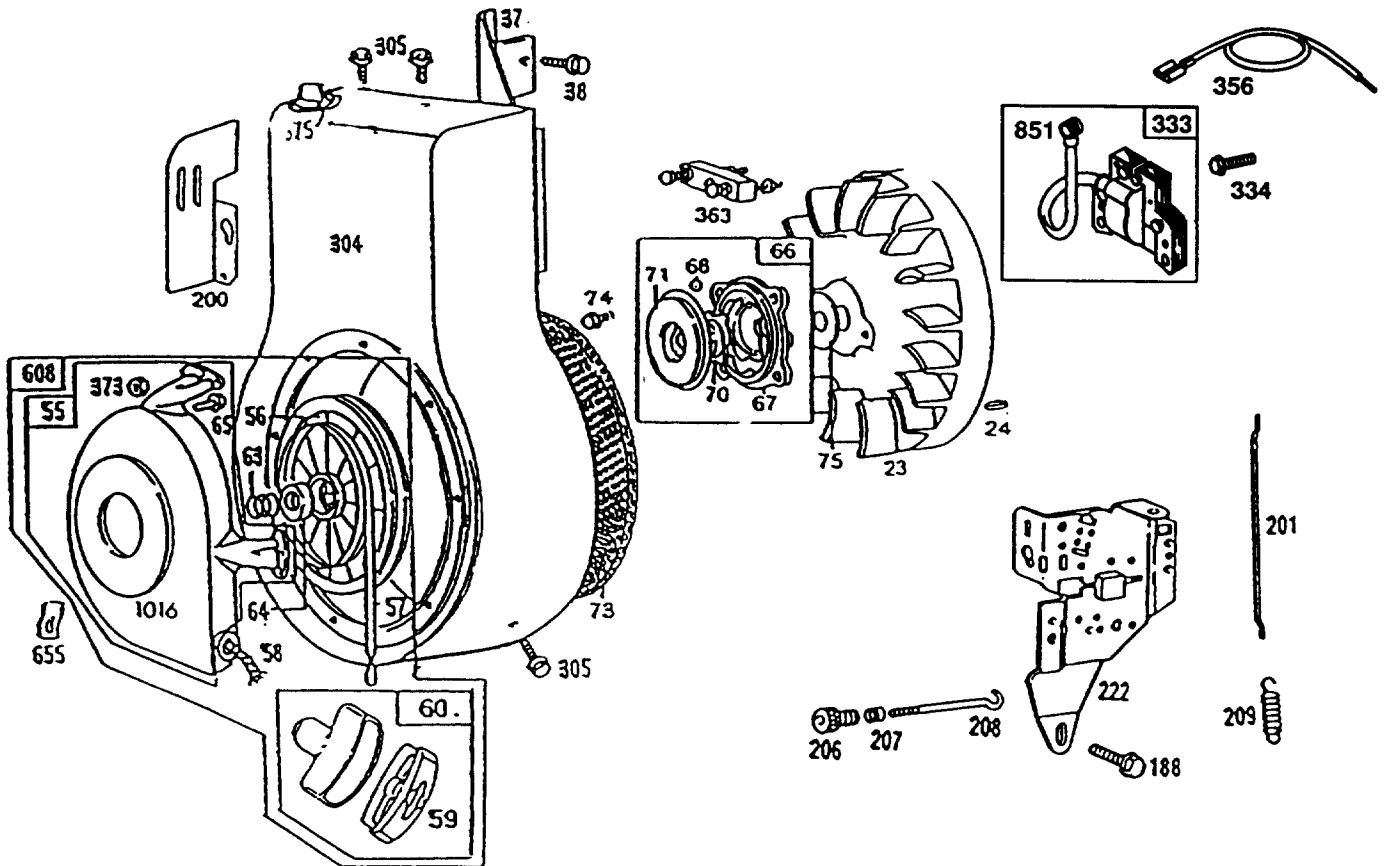

Assemblies include all parts shown in frames.

REF. NO.	PART NO.	DESCRIPTION	REF. NO.	PART NO.	DESCRIPTION
23	298260	Flywheel-Magneto	75	224061	Washer-Spring
24	222698	Key-Flywheel	188	93535	Screw-Sem
37	222475	Guard-Flywheel	200	221760	Guide-Air
38	93777	Screw-Sem	201	260872	Link-Governor
55	393576	Hsg.-Rewind Starter	206	231266	Nut-Gov. Control Rod
56	295871	Pulley-Rewind Starter	207	26855	Spring-Governor Control Rod
		Note: Includes 63" Rope.	208	261959	Rod-Governor Control
57	490179	Spring-Rewind Starter	209	260695	Spring-Governor
58	66884	Rope-Rewind Starter	222	399151	Plate-Gov. Control
59	490653	Insert-Starter Handle	304	491596	Housing-Blower
60	490652	Handle-Rew. Starter	305	94608	Screw-Sem
63	260414	Spring-Ratchet	333	398811	Armature-Magneto
64	230543	Adapter-Ratchet Spg.	334	93381	Screw Armature Mtg.
65	94128	Screw-Rewind Starter Housing Mounting	356	398874	Wire-Ground
66	399671	Clutch Assembly-Rewind Starter	363	19203	Puller-Flywheel
67	394897	Housing-Rewind Starter Clutch	373	92987	Nut-Hex.
68	63770	Ball-Clutch	575	396691	Switch-Rotary Stop
70	298799	Ratchet-Rewind Starter Clutch	608	390391	Starter Assy.-Rewind
71	394506	Washer-Clutch Ret.	655	222598	Anchor-Spring
73	221796	Screen-Rew. Starter	851	221798	Terminal-Ignition Cable
74	93758	Screw-Sem	1016	490817	Spacer

**BRIGGS AND STRATTON 8 H.P. ENGINE MODEL NOS. 190412-6143-01
190432-6117-01**

Repair Parts

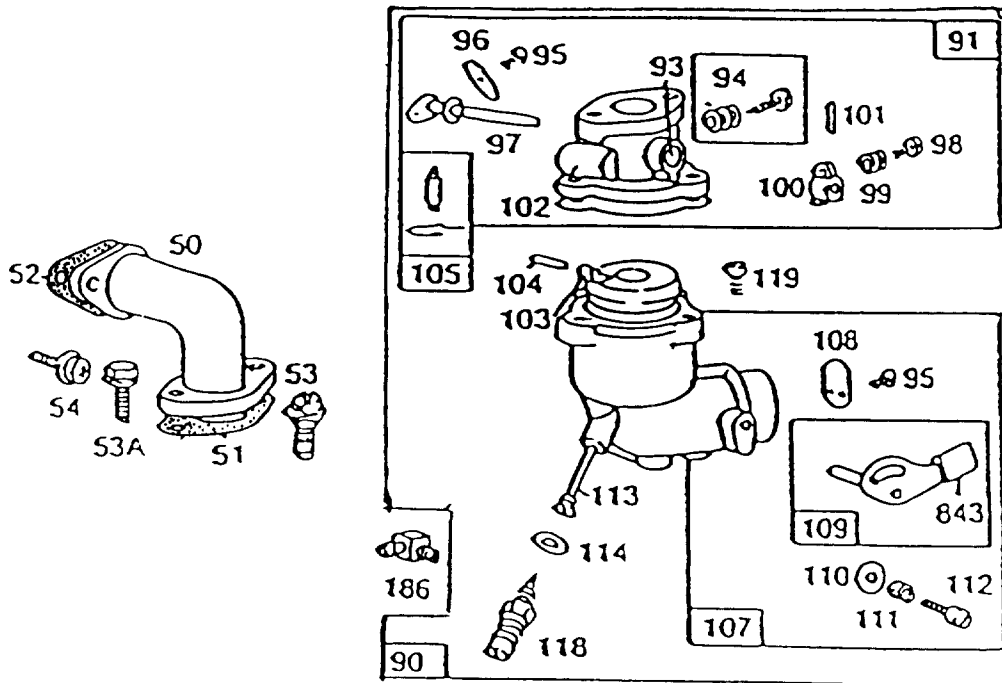

121 CARBURETOR OVERHAUL KIT

Assemblies include all parts shown in frames.

REF. NO.	PART NO.	DESCRIPTION	REF. NO.	PART NO.	DESCRIPTION
50	212488	Elbow-Intake	104	•230896	Pin-Float Hinge
51	*270684	Gasket-Carb. Mtg.	105	•394681	Valve-Fuel Inlet
52	*27828	Gasket-Intake Elbow Mounting	107	399442	Body Assembly-Lower Carburetor
53	93956	Screw-Shoulder	108	62872	Valve-Choke
53A	93357	Screw-Carburetor Mounting Sem	109	391987	Shaft and Lever-Choke
54	93208	Screw-Intake Elbow	110	222712	Washer-Choke Lever
90	390323	Carburetor Assembly	111	26155	Spring-Choke Lever
91	399443	Body Assembly-Upper Carburetor	112	23123	Screw-Choke Lever
93	23108	Bushing-Throttle Shaft	113	•398202	Nozzle-Carburetor
94	•292681	Valve Assembly-Carburetor Idle	114	•68667	Gasket-Nozzle
95	93499	Screw-Throttle and Choke Valve Mtg. Sem	118	•99525	Valve-Needle
96	223370	Valve-Throttle			Includes:
97	298826	Shaft and Lever-Throttle			22235 Washer-Brass
98	91920	Screw-Fil. Hd.			26336 Spring
99	26157	Spring-Throttle Adj.			65978 O-Ring
100	212904	Stop-Throttle	119	94152	394033 Valve-Needle
101	93043	Pin-Throttle Stop	121	398235	Screw-Hex. Hd. Sem
102	•27918	Gasket-Carb. Body	186	67218	Carburetor Overhaul Kit
103	99333	Float-Carburetor	843	280149	Connector-Fuel Pipe
					Sleeve-Choke Lever

* Included in Gasket Set—Part No. 299577.
• Included in Carburetor Overhaul Kit—Part No. 398235.

LOCALIZACION DE FALLAS

PROBLEMA	CAUSAS(S) POSIBLE	ACCION CORRECTIVA
El motor no se enciende	<ul style="list-style-type: none"> ● Válvula de cierre de combustible cerrada. ● El tanque de combustible está vacío, ● El combustible rancio. ● El cable de la bujía está desconectado. ● Bujía defectuosa. 	<ul style="list-style-type: none"> ● Abra la válvula de cierre. ● Llene el tanque con combustible limpio, fresco. ● Conecte el cable a la bujía. ● Limpie, ajuste el espacio o reemplace.
Pérdida de potencia: operación irregular	<ul style="list-style-type: none"> ● El cable de la bujía está flojo. ● La unidad está funcionando en CHOKE. ● La línea de combustible está bloqueada. ● El combustible rancio. ● Agua o suciedad en el sistema de combustible. ● El carburador está desajustado. ● Filtro de aire sucio. 	<ul style="list-style-type: none"> ● Conecte y ajuste el cable de la bujía. ● Mueva la palanca del regulador a la posición OFF. ● Limpie la línea de combustible; llene el tanque con gasolina limpia, fresca. ● Desconecte la línea de combustible en el carburador para drenar el tanque de combustible. ● Llene con gasolina fresca. ● Ajuste el carburador o llame a su Centro de Servicio Sears. ● Sirva el filtro de aire. Vea la sección de Responsabilidades del Cliente de este manual.
El motor sobrecalienta	<ul style="list-style-type: none"> ● El carburador no está ajustado adecuadamente. ● Nivel bajo de aceite. 	<ul style="list-style-type: none"> ● Llame a su Centro de Servicio Sears. ● Llene el cárter con aceite adecuado.
Demasiada vibración dañado	<ul style="list-style-type: none"> ● Piezas sueltas o impulsor. 	<ul style="list-style-type: none"> ● Apague inmediatamente el motor y desconecte el cable de la bujía. Ajuste todos los pernos y tuercas. Efectúe todas las reparaciones necesarias. Haga que sirvan la unidad en un Centro de Servicio Sears si la vibración continúa.
La unidad no descarga	<ul style="list-style-type: none"> ● La canalleta de descarga está taponada. 	<ul style="list-style-type: none"> ● Apague inmediatamente el motor y desconecte el cable de la bujía. Limpie el tamiz de la desgranadora y el interior de la cubierta del soplador. Vea la sección de Servicio/Ajustes de este manual. ● Apague inmediatamente el motor y desconecte el cable de la bujía. Retire el objeto alojado.
La velocidad de descarga disminuye o considerablemente cambia la composición del material descargado	<ul style="list-style-type: none"> ● La cuchilla de desmenuzar y/o las cuchillas de picar están desafiladas. 	<ul style="list-style-type: none"> ● Afíle y reemplace las cuchillas de desmenuzar y picar.

cercano.

NOTA: Para reparaciones diferentes a los ajustes menores listados arriba, por favor llame a su Centro de Servicio Sears más

COMO ORDENAR PIEZAS DE REPUESTO

Cada picadora-desmenuzadora tiene su número propio de modelo. Cada motor tiene su número propio de modelo.

El número de modelo para su picadora-desmenuzadora se encuentra en un rótulo pegado al marco.

El número de modelo del motor se encuentra en la cubierta del soplador del motor.

Todas las piezas listadas aquí pueden ordenarse de los Centros de Servicio de Sears Roebuck and Co. y en la mayoría de las tiendas al por menor.

CUANDO ORDENE PIEZAS DE REPUESTO SIEMPRE PROPORCIONE LA INFORMACION SIGUIENTE:
● PRODUCTO - "PICADORA-DESMENUZADORA DE 8 H.P."

Su mercadería de Sears tiene un valor agregado cuando usted considera que Sears tiene unidades de servicio en todo el país con personal técnico entrenado de Sears... técnicos profesionales entrenados específicamente en los productos de Sears, teniendo las piezas, herramientas y el equipo para asegurar que cumplamos con nuestra promesa a usted... servimos lo que vendemos."

- NUMERO DE MODELO -247.795860, 247.795861
- NUMERO DE MODELO DEL MOTOR - 190412-6143-01 190432-6117-01
- NUMERO DE PIEZA
- DESCRIPCION DE LA PIEZA

Free Manuals Download Website

<http://myh66.com>

<http://usermanuals.us>

<http://www.somanuals.com>

<http://www.4manuals.cc>

<http://www.manual-lib.com>

<http://www.404manual.com>

<http://www.luxmanual.com>

<http://aubethermostatmanual.com>

Golf course search by state

<http://golfingnear.com>

Email search by domain

<http://emailbydomain.com>

Auto manuals search

<http://auto.somanuals.com>

TV manuals search

<http://tv.somanuals.com>