



# Polycom® RMX 1000™ System User Guide

2.1.0 | July 2009 | 3150-16966-002

---

### **Trademark Information**

Polycom®, the Polycom “Triangles” logo, and the names and marks associated with Polycom’s products are trademarks and/or service marks of Polycom, Inc., and are registered and/or common-law marks in the United States and various other countries.

All other trademarks are the property of their respective owners.

### **Patent Information**

The accompanying product is protected by one or more U.S. and foreign patents and/or pending patent applications held by Polycom, Inc.

© 2009 Polycom, Inc. All rights reserved.

Polycom, Inc.  
4750 Willow Road  
Pleasanton, CA 94588-2708  
USA

No part of this document may be reproduced or transmitted in any form or by any means, electronic or mechanical, for any purpose, without the express written permission of Polycom, Inc. Under the law, reproducing includes translating into another language or format.

As between the parties, Polycom, Inc., retains title to and ownership of all proprietary rights with respect to the software contained within its products. The software is protected by United States copyright laws and international treaty provision. Therefore, you must treat the software like any other copyrighted material (e.g., a book or sound recording).

Every effort has been made to ensure that the information in this manual is accurate. Polycom, Inc., is not responsible for printing or clerical errors. Information in this document is subject to change without notice.

## Regulatory Notices

### United States Federal Communication Commission (FCC)

**Part 15: Class A Statement.** This equipment has been tested and found to comply with the limits for a Class A digital device, pursuant to Part 15 of the FCC Rules. Test limits are designed to provide reasonable protection against harmful interference when the equipment is operated in a commercial environment. This equipment generates uses and can radiate radio-frequency energy and, if not installed and used in accordance with the instruction manuals, may cause harmful interference to radio communications. Operation of this equipment in a residential area is likely to cause harmful interference, in which case the user will be required to correct the interference at his or her own expense.

### CE & UL Mark

Polycom Inc., declares that the Polycom RMX 1000 is in conformity with the following relevant harmonized standards:

EN 60950-1:2001+A11:2004  
EN 55022:2006  
EN 55024:1998/A1:2001/A2:2003  
EN 61000-3-2:2006  
EN 61000-3-3:1995/A1:2001/A2:2005  
UL Listed (USA)  
CUL Listed (Canada)

Following the provisions of the Council Directive 1999/CE on radio and telecommunication terminal equipment and the recognition of its conformity.

### Compliant with European Battery Directive 2006/66/EC

To comply with the European Battery Directive 2006/66/EC, dispose of weak and worn out batteries in accordance with local and national regulations.

# Table of Contents

<b>System Overview .....</b>	<b>1-1</b>
RMX 1000 .....	1-1
RMX 1000 Main Features .....	1-3
Video Display .....	1-3
LPR .....	1-3
IVR-Enabled Conferencing .....	1-4
Recording Link .....	1-4
Conferencing Capabilities and Options .....	1-4
User Interfaces .....	1-5
Full Integration with CMA .....	1-5
<b>First Time Installation and Configuration .....</b>	<b>2-1</b>
Hardware Installation and Setup .....	2-1
Configuration Preparations .....	2-2
Obtaining Network Information .....	2-2
Obtaining Product Activation Key .....	2-2
First Time Configuration .....	2-3
Connect PC to RMX 1000 .....	2-3
Logging in to Web User Interface .....	2-4
Modify the Default IP address .....	2-5
Configuring Other Network Options (Optional) .....	2-7
Synchronizing System Time .....	2-10
<b>Basic Operation .....</b>	<b>3-1</b>
RMX 1000 Screen Components .....	3-1
User Rights .....	3-1
Pane Layout .....	3-3
Common Operations .....	3-4
Starting a Conference .....	3-6
Starting a Conference from the Conferences Pane .....	3-6
Starting a Conference Using the Remote Control – Conference on Demand .....	3-7
Connecting to a Conference–Dialing Methods .....	3-11
H.323 Endpoint .....	3-11

SIP Endpoint .....	3-11
<b>Conference Profiles .....</b>	<b>4-1</b>
Defining a Conference Profile .....	4-2
General Settings .....	4-3
Video Quality .....	4-4
Video Settings .....	4-7
Conference Skin Settings .....	4-9
Conference Recording .....	4-10
Message Overlay .....	4-12
Site Name .....	4-13
Advanced Options .....	4-13
Modifying a Profile .....	4-14
Deleting a Profile .....	4-14
Setting a Default Profile .....	4-14
<b>Recording Link.....</b>	<b>5-1</b>
Recording Setup .....	5-1
General Settings .....	5-2
DTMF Code Setting .....	5-2
Recording Control .....	5-3
Recording Properties .....	5-4
<b>Meeting Rooms .....</b>	<b>6-1</b>
Creating a Meeting Room .....	6-1
Modifying a Meeting Room .....	6-4
Deleting a Meeting Room .....	6-4
<b>Reservations .....</b>	<b>7-1</b>
Reservations Views .....	7-1
Calendar View .....	7-1
List View .....	7-2
Adding a Reservation .....	7-3
Reserving a One-Time Conference .....	7-3
Reserving a Daily Conference .....	7-4
Reserving a Weekly Conference .....	7-4
Reserving a Monthly Conference .....	7-5
Modifying a Reservation .....	7-6
Deleting a Reservation .....	7-6

<b>Address Book .....</b>	<b>8-1</b>
Adding a Participant to the Local Directory .....	8-2
Creating a Participant in the Address Book .....	8-2
Adding a Participant from an Ongoing Conference .....	8-6
Defining a Participant Group .....	8-6
Modifying a Participant/Group .....	8-7
Deleting a Participant/Group .....	8-7
Importing and Exporting the Local Directory .....	8-7
Exporting the Local Directory .....	8-7
Importing the Local Directory .....	8-7
Directory Service .....	8-8
Configuring Directory Service .....	8-8
Viewing the Global Directory .....	8-10
Searching Directory Entries .....	8-11
<b>Conference/Participant Monitoring .....</b>	<b>9-1</b>
Conference Monitoring .....	9-1
Viewing Conferences List Pane .....	9-1
Viewing Conference Parameters .....	9-2
Conference Control .....	9-2
Participant Monitoring .....	9-6
Viewing Participant List .....	9-6
Viewing Participant Properties .....	9-8
Participant Control .....	9-8
Control Operations .....	9-9
<b>Users and Connections .....</b>	<b>10-1</b>
User List .....	10-2
Defining New User .....	10-2
Deleting User .....	10-3
Modifying User Password .....	10-3
Viewing User Connection .....	10-4
<b>IP Service Settings .....</b>	<b>11-1</b>
LAN Setting .....	11-2
Routers .....	11-3
Gatekeeper .....	11-4
SIP Server .....	11-5

QoS .....	11-7
Ports .....	11-8
Email .....	11-9
<b>IVR Service .....</b>	<b>12-1</b>
Default IVR Information .....	12-2
Customizing IVR Information .....	12-3
Replace the IVR information .....	12-3
Recording an Audio Message .....	12-4
<b>CDR .....</b>	<b>13-1</b>
CDR Files .....	13-1
Viewing CDR Records .....	13-2
Saving CDR Records .....	13-3
<b>RMX Utilities .....</b>	<b>14-1</b>
System Alerts .....	14-1
H.323/SIP Link .....	14-2
System Time .....	14-2
Customization .....	14-3
Modifying Language .....	14-4
Setting System Name .....	14-4
Setting Skins .....	14-4
Security Setting .....	14-6
SNMP Setting .....	14-8
Setting the Agent .....	14-8
Setting Traps .....	14-9
Product Activation .....	14-10
Logger Diagnostics Files .....	14-12
Software Management .....	14-12
Backup Configuration/Reservation .....	14-13
Restoring Configuration/Reservation .....	14-13
Resources Report .....	14-14
Device Upgrade .....	14-15
Upgrading from Version 1.1 to Version 2.1 .....	14-15
Activating the Upgraded System .....	14-19
<b>Signaling and Hardware Monitoring .....</b>	<b>15-1</b>
Signaling Monitoring .....	15-1

Hardware Monitor .....	15-2
<b>Personal Conference Manager (PCM).....</b>	<b>16-1</b>
Introduction to PCM Interfaces .....	16-2
Viewing the PCM Interface .....	16-2
Definitions of DTMF & FECC Keys .....	16-3
PCM Operations .....	16-4
Creating a Conference .....	16-4
Entering an Existing Conference .....	16-5
Conference Control for Regular Participants .....	16-7
Chairperson Conference Control .....	16-9
<b>Appendix A: Connection Failure Diagnosis .....</b>	<b>17-1</b>
<b>Appendix B: Telnet/Terminal Commands .....</b>	<b>18-1</b>
HyperTerminal Parameters .....	18-1
Login .....	18-1
Command Introduction .....	18-2
<b>Appendix C: Glossary .....</b>	<b>19-1</b>
<b>Third Party Software Licenses .....</b>	<b>20-1</b>





---

# System Overview

This chapter will serve as a brief introduction to the RMX 1000 system and its major functions and features. The following chapters provide detailed description about the installation of RMX 1000 system, as well as how to hold, manage, monitor conferences and maintain the device.

## RMX 1000

The Polycom real-time media conferencing platform (RMX 1000) is a high-value multipoint platform for small IP networks or remote locations on large IP networks.

The Polycom RMX 1000 provides the following features:

- All-in-one (video, audio and contents) box is easy to install, configure, and manage
- Supports video conferences for devices supporting H.323 and SIP protocol such as IP phones, SIP phones and Video
- Provides high quality audio, video and content sharing
- Provides the Polycom Lost Packet Recovery (LPR) function to ensure an optimal experience even on sub-optimal networks
- Familiar user interface and web interface (same as RMX 2000)
- Siren 22 Stereo
- Supports H.264 content
- Simple Network Management Protocol (SNMP) Support
- Security Socket Layer (SSL) certificate encryption Support
- Tight integration with Polycom RSS 2000 – Recording and Streaming Server
- Supports internal reservation (optional), as well as external reservation through Polycom CMA
- Personal Conference Manager (PCM)

The Polycom RMX 1000 Multipoint Control Unit (MCU) meets International Telecommunication Union-Telecommunication Standardization Sector (ITU-T) standards for multipoint multimedia bridging devices, and meets ETSI standards for telecommunication products.

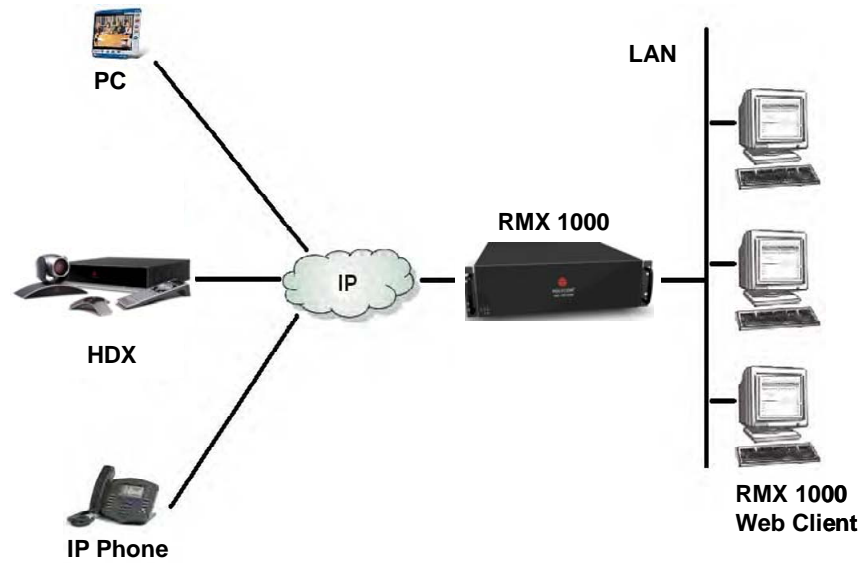

**Figure 1-1** Multipoint Video Conferencing Using a Polycom RMX 1000

# RMX 1000 Main Features

## Video Display

### Dynamic Continuous Presence (CP)

The dynamic Continuous Presence capability of the RMX 1000 system ensures viewing flexibility by offering multiple viewing points and window layouts for video conferencing. The Continuous Presence (CP) mode offers a number of different onscreen layouts to accommodate different numbers of participants and conference settings.

### High Definition

High Definition (HD) refers to high-quality picture resolution. An HD-compliant endpoint can connect to a conference at a resolution of 1280x720 (720p) and a bit rate of 832kbps ~ 2Mb.

### Multiple Switching Modes

If the number of participants in a conference is higher than the number of onscreen spaces in the selected layout, the RMX 1000 system supports switching between video participants in one of these modes:

- Voice activation
- Administrator – specified (one or more participants configured for display in a selected video window).
- Lecture Mode – The lecturer is viewed in full screen by all conference participants, while the audience is rotated through the lecturer's view in a "time-switched" mode.

### H.239

An H. 239 compliant endpoint can simultaneously send or receive two separate video streams: video and data. The data streams are treated differently by the endpoint, and may be shown on separate screens. This can be used for training, remote direction and displaying necessary information for reporting.

### Media Encryption

The system has an optional AES 128-bit media encryption mode, so the conferencing connection is more secure.

## LPR

LPR (Lost Packet Recovery) is a Polycom algorithm designed to protect IP video calls from the impact of network packet loss. LPR offers five key benefits:

- Allows users to conduct high quality video calls over packet loss-prone IP networks (DSL, cable, satellite, high contention LANs/WANs, etc.) without suffering the effects of packet loss.
- Protects video calls from short-term network issues by temporarily adjusting the bit rate of the call in progress.
- Reduces the jitter buffer and associated delay.
- Allows an organization to use all available bandwidth for its video calls.
- Protects all elements of the videoconference call; voice, video and content.

## IVR-Enabled Conferencing

The Interactive Voice Response (IVR) function lets participants perform various operations during ongoing conferences according to voice prompts. The participants use their endpoints' keypads and remote control to interact with the conference's menu-driven scripts using Far-End Camera Control (FECC) and DTMF codes.

## Recording Link

The RMX 1000 system supports recording links similar to other Polycom MCUs. This recording link can work with the Polycom RSS 2000 to record the content of an RMX 1000 conference.

## Conferencing Capabilities and Options

### On Demand Conferencing

The following options are available when setting up conferences:

- Instant Conference – Convene an instant one-time-only conference. The conference is deleted from the MCU immediately after its completion.
- Meeting Room – Meeting rooms are stored in the MCU memory, without occupying any MCU resources until used. They can be activated anytime.
- Reserve a Conference – The reserved conference is stored on the CMA (or RMX 1000, if using internal scheduling) and occupies resources only during the specified timeframe. The system automatically initiates and terminates the conference according to the reservation start and end times. A user can reserve a conference by purchasing the CMA or RMX1000 internal scheduling activation key.

### Connection Methods

- Dial-out: automatically connect pre-defined participants (automatic line rate detection)
- Dial-in:
  - Inbound calling by pre-defined participants
  - Inbound calling by undefined participants

## Directory Service

The RMX1000 fully supports the Global Address Book (GAB) and Microsoft Lightweight Directory Access Protocol (LDAP) directory service, and enables the user to share the GAB resources and view presence status

## Conference Management and Monitoring Features

The Polycom RMX 1000 Web Client provides capabilities for management and monitoring of participants and conferences as follows:

- Lecture Mode in Continuous Presence conferences
- Previewing snapshot of each participant site in the user interface (for admin usage)
- Far End Camera Control (FECC/LSD) in video conferences
- Automatic termination of empty (no participant) conferences
- Control of listening and broadcasting audio volume for individual participants
- Conference control via DTMF codes from participant's endpoint or telephone
- Multimedia Encryption
- SSL Certificate Encryption (Https)
- Real-time display of all conferences and participants
- Real-time monitoring of each participant's connection status and properties
- Easily accessible Call Detail Records (CDR) for administrator
- Active display of all system resources

## User Interfaces

### Web Interface

The system provides a user-friendly Web-based operations interface. To conveniently and easily manage and monitor conferences, or maintain the device, the user only needs to access the Web client program of the RMX 1000 system by using the IE browser at the PC. The Web interface is designed for both administrator and operator level users.

### Personal Conference Manager (PCM)

The Personal Conference Manager (PCM) is a menu-based onscreen interface viewed on a participant's endpoint. The user can perform common conference operations using the endpoint's remote control and onscreen operation menus. The interface is designed for end users.

## Full Integration with CMA

The RMX 1000 system can be completely integrated with the Polycom CMA for centrally-managed scheduling. The CMA can manage RMX 1000 as

follows:

- Viewing details of the RMX 1000 system
- Modifying conference profiles and scheduling conferences
- Monitoring ongoing conferences
- Managing the ongoing conference and participants, e.g. extending the conference time, terminating the conference, adding/deleting a participant and sending notification E-mails to a participant.

---

# First Time Installation and Configuration

Follow the procedure below to implement First Time Installation and Configuration of the RMX 1000 system:

- 1 Hardware Installation and Setup
- 2 Configuration Preparations
  - Get the information needed for network configuration.
  - Get the product activation key.
- 3 First Time Configuration
  - Connect a PC to the RMX 1000
  - Log in to the Web interface
  - Modify the default IP address
  - Configure other network options
  - Synchronize the system time

## Hardware Installation and Setup

Install the hardware and connect lines as described below:

- 1 Put the RMX 1000 product on a stable surface at the installation site.
- 2 Carefully take the RMX 1000 device out of the package. You can install the device in the rack or position it on an even surface.
  - Mount the RMX 1000 in the rack: Install rack brackets, supplied by the rack manufacturer, in the rack. Mount the RMX 1000 on top of the rack brackets. Fasten the RMX 1000 to the rack with screws.



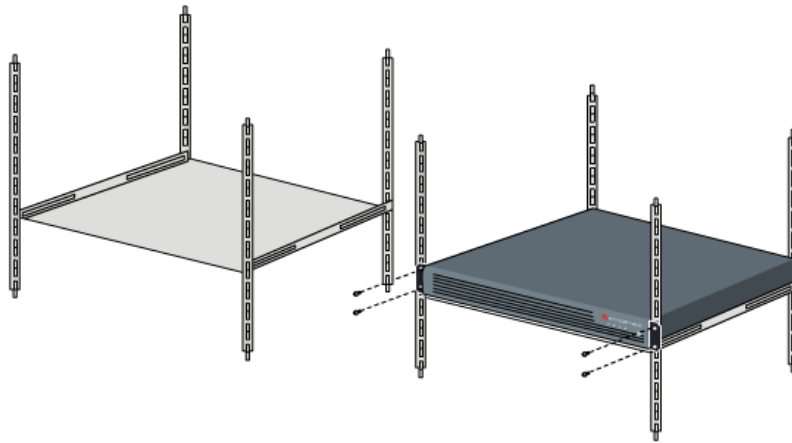

**Figure 2-1** Replace RMX 1000 on the rack.

- Put the RMX 1000 on a safe, even, and clean surface.
- 3** Connect cables on the back panel of the RMX 1000:
- Power Cable: Firmly insert the plug into the power socket to prevent poor contact.
  - LAN Cable: Connect to the LAN1 port of the RMX 1000.



If you want to shut off the device, please first turn off the power switch. Do not directly cut off the power supply or unplug the power cable.

## Configuration Preparations

### Obtaining Network Information

Before the first time configuration, obtain the information below from the network administrator:

- Confirm the IP network type (H.323, SIP or H.323&SIP) and related configuration information.
- The IP address, subnet mask, and default gateway IP address of the RMX 1000 LAN port
- (Optional) DNS server address
- (Optional) Gatekeeper address, and the H.323 prefix and E.164 number to be assigned to the RMX 1000
- (Optional) SIP server address

### Obtaining Product Activation Key

Before using the RMX 1000, you need to register and activate the device. Follow the procedure below to obtain the product activation key. When you power on and log in to the RMX 1000 for the first time, the system displays the Product Activation dialog box, requesting you to enter a Product Activation Key.

- 1 Enter <http://portal.polycom.com> in the address bar of the browser to access the login page of the Polycom resource center.
- 2 In the login box, enter your Email address and password, and then click **Login**. If you are a new user, click the **Register for an Account** link for registration.
- 3 Click **Service & Support-> Product Activation -> Overview** in the upper navigation bar on the interface.

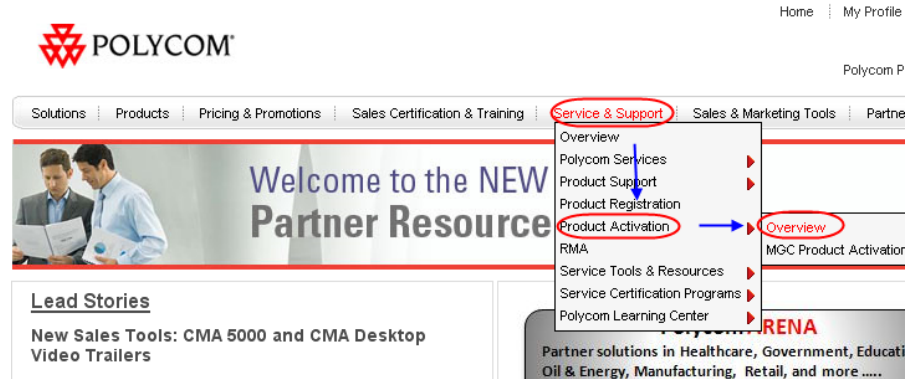

Figure 2-2 Service & Support Interface

- 4 Enter the *Activate Your Product* page. Enter the **License Number** and **Serial Number** of the product in the *Single License Number* pane, and then click the **Generate** button. You can find the license number and serial number of the product from the document provided with the RMX 1000. Record the activation key displayed in the *Key Code* field.

The screenshot shows the 'Single License Number' activation key generating page. The page has a red header with the text 'Single License Number'. Below the header, there is a text box with the following instructions: 'Please enter the License Number and Serial Number of your product to generate a Key Code. To retrieve a previously enabled Key Code, please enter the product's serial number and leave License Number blank.' Below the instructions, there are three input fields: 'License Number:', 'Serial Number:', and 'Key Code:'. The 'License Number' and 'Serial Number' fields are empty. Below the input fields, there is a yellow 'Generate' button.

Figure 2-3 Activation Key Generating Page

## First Time Configuration

### Connect PC to RMX 1000

- 1 Connect your PC to the LAN1 port (the LAN1 port is enabled by default) of the RMX 1000 with a cross - over network cable, or connect your PC and RMX 1000 to the same switch in the LAN. Turn on the power switch at the RMX 1000.
- 2 Configure the IP address for your PC, which is in the same network segment as the IP address of the RMX 1000.
- 3 The default IP address of the RMX 1000 before delivery is:

- IP address of the LAN1 port - **192.168.1.254**
  - Subnet mask - **255.255.255.0**
  - Default gateway IP address - **192.168.1.1**
- 4 You can also view the current address information of the product using the RMX 1000 Discover tool provided with the device.
- a Run the RMXDiscover.exe file in the CD provided with the product.
  - b Click the Discover button to display the current address information of the device.

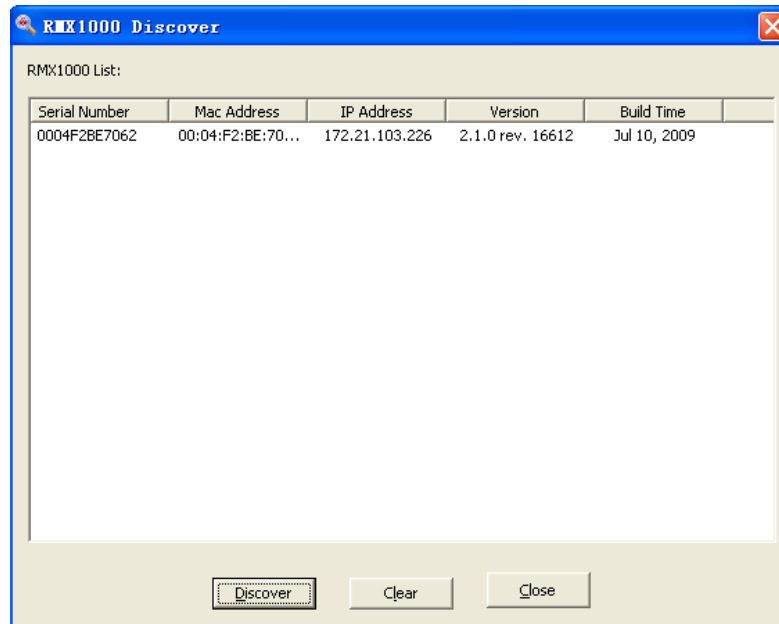

Figure 2-4 RMX 1000 Discover Tool Interface

## Logging in to Web User Interface





Please make sure that you are using IE 7.0 or Firefox 3.0(or above) browser in order to get the best experience when working with RMX 1000 Web UI.

- 1 Run the Web browser on the PC. Enter **http://<RMX 1000 IP address>** in the address bar, and then press **Enter**.
- 2 (Optional) Select a language for the Web interface from the drop-down menu. If the browser or OS of your PC does not support the selected language, the content is displayed in English.
- 3 On the Login screen, enter the default **User Name (POLYCOM)** and **Password (POLYCOM)**. Click the **Login** button to enter the *Web configuration* interface.



**Figure 2-5** Logging in to the RMX 1000 Web Interface

- 4 The *Product Activation* dialog box is displayed. Fill in the activation key obtained in *Obtaining Product Activation Key* in the *Activation Key* box, and then click the **Save** button. Click the **Close** button.
- 5 The system displays a message asking whether to restart the system or not. Click **Restart Now** to validate the activation.
- 6 After the system restarts, you can enter the **Administration** -> **License Information** interface in the Web configuration interface to check the activated functions. For the activated functions,  is displayed, or else  is displayed.

## Modify the Default IP address

After accessing the RMX 1000 Web configuration interface, you can modify the default IP address for the device based on the settings of your local network.

- 1 Click the **IP Network Services** configuration item in the *RMX Management* pane.
- 2 In the *IP Network Services* configuration pane, double-click or right-click **LAN 1** -> **Properties**.
- 3 In the *LAN1 Properties* interface, set the IP address obtained from the network administrator, and configure the device for use on your local network.

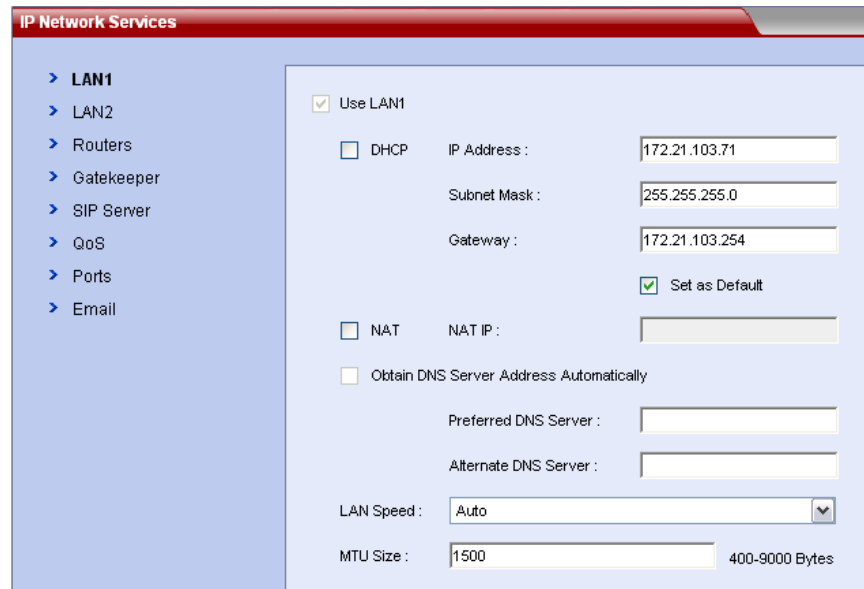

Figure 2-7 IP Network Services – LAN Settings

Table 2-1 LAN Port Setting Parameters

Parameter	Description
<i>Use LAN1</i>	Enables/disables the network port.
<i>DHCP</i>	If the user network is configured with a Dynamic Host Configuration Protocol (DHCP) server, select this option to automatically obtain the IP address. Deselect this option to use a static IP address, in which case you need to configure the next three options.
<i>IP Address</i>	Set the IP address for this network port.
<i>Subnet Mask</i>	Set the Subnet Mask for this network port.
<i>Gateway</i>	Set the gateway address of this port. If <b>Set as Default</b> is selected and no matched static routes is found, the device packets will be transmitted via this gateway by default. In this case, a default route is displayed in the list of <i>Routers</i> page. For details, see <i>Routers</i> .
<i>NAT</i>	The Network Address Translation (NAT) function of the system enables you to translate the private network IP address of packet into a public network IP address before transmission. To enable NAT, select this check box and then set the public network IP address to be displayed to the outside in the <i>NAT IP</i> field.
<i>Obtain DNS Server Address Automatically</i>	Used in combination with the DHCP option. When the DHCP check box is selected, this option allows you to obtain the DNS server address automatically from a DHCP server in the network.
<i>Preferred/Alternate DNS Server</i>	If you did not select the option for automatic DNS address discovery, you must enter the preferred/alternate DNS server addresses here for the device to resolve domain names.

Parameter	Description
LAN Speed	Sets the speed/duplex modes for LAN ports. Supported speed/duplex modes include 10/100M, Full Duplex or Half Duplex, and the 1000M Network mode. You can also select <b>Auto</b> to use Auto-Negotiation with the switch port. <b>Note:</b> Contact the network administrator before setting LAN Speed, to ensure that the switch configuration is matched with the MCU port.
MTU Size	Specifies the Maximum Transmission Unit (MTU) size used in IP calls and Web communications. If the video becomes blocky or network errors occur, packets may be too large; decrease the MTU. If the network is burdened with unnecessary overhead, packets may be too small; increase the MTU.

## Configuring Other Network Options (Optional)

If necessary, you can configure other network parameters according to the following procedure:

- 1 Click the **IP Network Services** configuration item in the *RMX Management* pane.
- 2 In the *IP Network Services* configuration pane, double-click or right-click **LAN 1 -> Properties**.
- 3 Click the **Routers** tab, and set the routing table information according to the network topology.

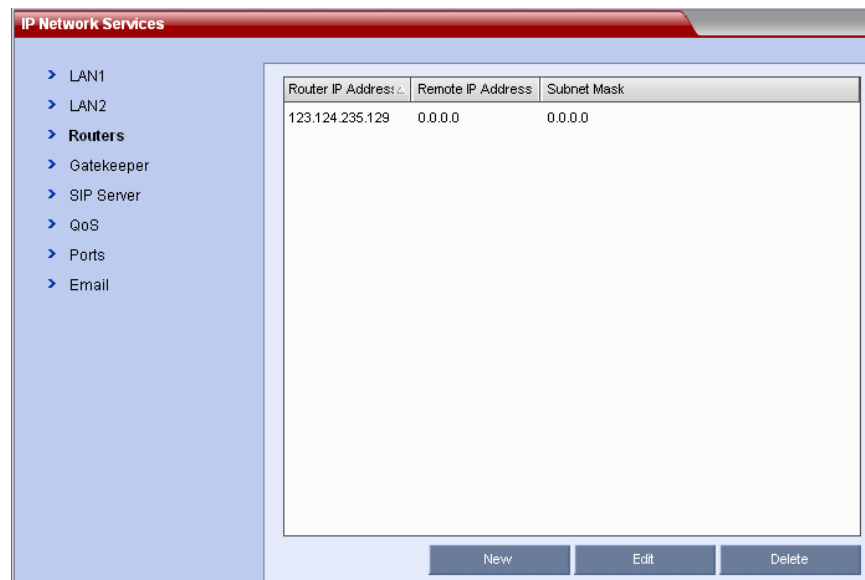

Figure 2-8 IP Network Services – Route Settings

Table 2-2 Routers Setting

Parameter	Description
Router IP Address	Set the IP address for the sending router of packet transmission.

Parameter	Description
<i>Remote IP Address</i>	Set the target network address for packet transmission.
<i>Subnet Mask</i>	Set the subnet mask for the target network.

- 4 If your IP network type is SIP only, go to step 7.
- 5 To register the system to the gatekeeper, click the **Gatekeeper** tab, and configure related parameters in accordance with the table below:



Figure 2-9 IP Network Services – Gatekeeper

Table 2-3 Gatekeeper Setting

Parameter	Description
<i>IP Network Type</i>	Set the IP network type for the RMX 1000 system to make a call. You need to set it based on the call type used for the participant's endpoint. It can be set to: <ul style="list-style-type: none"> <li>▪ <b>H.323:</b> Only H.323 calls are supported.</li> <li>▪ <b>SIP:</b> Only SIP calls are supported.</li> <li>▪ <b>H.323 &amp; SIP:</b> H.323 and SIP calls are supported at the same time.</li> </ul> Settings of the gatekeeper related parameters are available only when the H.323 network type is selected.
<i>Register to Gatekeeper</i>	Set whether or not to register with the gatekeeper. You must check this option to set the parameters that follow.
<i>Primary (Alternate) Gatekeeper</i>	Indicates whether or not the device is registered with the primary (or alternate) gatekeeper.
<i>Gatekeeper IP Address</i>	Set the IP address for the primary (or alternate) gatekeeper.
<i>Gatekeeper Port</i>	The port number for the primary (or alternate) gatekeeper.
<i>System Prefix/E164.</i>	Set the E.164 number for the system.

Parameter	Description
System H.323 Alias	Set the H.323 alias for the system.

- 6 If your IP network type is H.323 only, go to step 8.
- 7 To configure the SIP server, click the **SIP Server** tab, and configure related parameters in accordance with the table below:

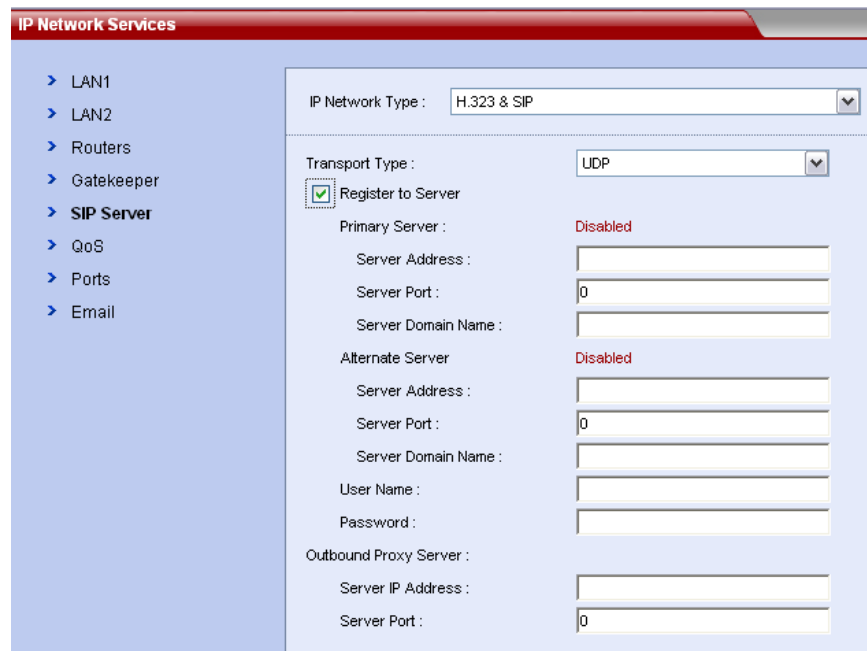

Figure 2-10 IP Network Services –SIP Server

Table 2-4 Configuration Description of SIP Server Parameters

Parameter	Description
IP Network Type	<p>Set the IP network type for the RMX 1000 system to make a call. You need to set it based on the call type used for the participant's endpoint. It can be set to:</p> <ul style="list-style-type: none"> <li>▪ <b>H.323:</b> Only H.323 calls are supported.</li> <li>▪ <b>SIP:</b> Only SIP calls are supported.</li> <li>▪ <b>H.323 &amp; SIP:</b> H.323 and SIP calls are supported at the same time.</li> </ul> <p>Settings of the SIP server related parameters are available only when the SIP network type is selected.</p>
Transport Type	Set the transport layer protocol used for communicating with the SIP server. It needs to be consistent with the protocol supported by the SIP server.
Register to Server	Specifies whether to register RMX 1000 to the specified SIP server. You need to set the SIP server related parameters after this function is enabled.
Primary Server/Alternate Server	Displays the registration status of the SIP server. When registration of the preferred server fails, the alternate server will function as the current in-use SIP server.



Parameter	Description
Server Address	Provides the IP address of SIP server for registration service.
Server Port	Provides the connection port of SIP server for registration service.
Server Domain Name	Provides the domain name of SIP server for registration service.
User Name	User name provided by the SIP server for the registered user.
Password	Password corresponds with the user name.
Outbound Proxy Server	For communication with the SIP server when the RMX 1000 system is configured on the internal network, an outbound proxy server is required to implement traversal of the firewall/NAT. In this case, you need to set the IP address and port number for the outbound proxy server.

8 Click the **OK** button to complete the configuration.

For more network service configuration information, see *IP Service Settings*.

## Synchronizing System Time

Before holding a conference using the RMX 1000 system, you need to first synchronize the system time to ensure that the conference scheduling time is consistent with your local time.

1 In the Web configuration interface, click **Setup** -> **RMX Time** to go to the system time configuration interface.

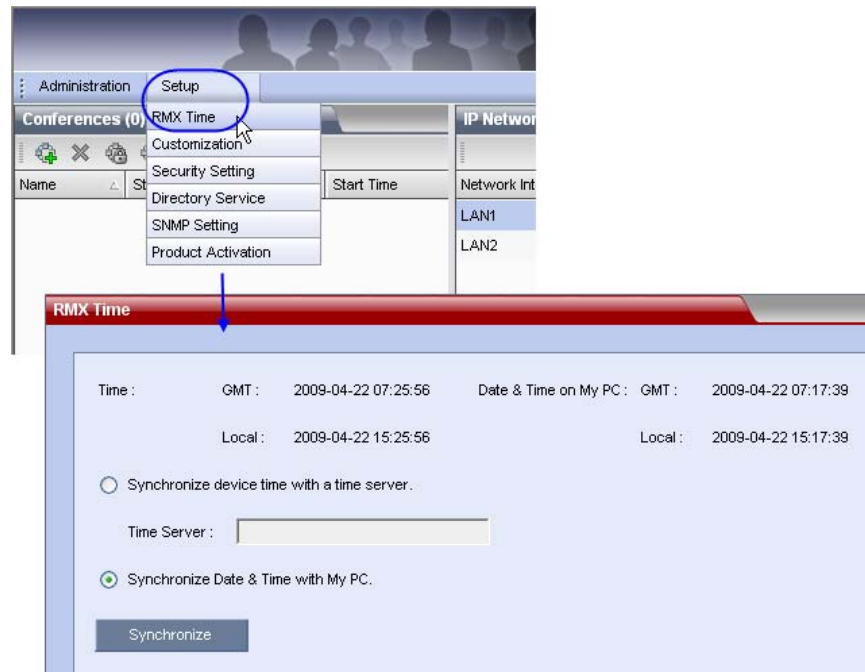

Figure 2-11 RMX Time

- 2 Select a time synchronization mode:
  - Select the **Synchronize device time with a time server** option to synchronize the device time with a network time server. In this case, enter the IP address or domain name for the time server in the *Time Server* field.
  - Select the **Synchronize Date&Time with My PC** option to synchronize the device time with your PC that is connected to the system.
- 3 Click the **Synchronize** button to proceed with the synchronization. Then, click **Close**.



# Basic Operation

This chapter introduces the Web UI components of the RMX 1000 and common operations, and how to start a simple conference. The goal of this chapter is to provide a quick guide on how to start a conference with minimal effort.

## RMX 1000 Screen Components

The Web configuration homepage of the RMX 1000 consists of five panes:

- Conference List
- RMX Management
- List Pane
- Address Book
- Status Bar

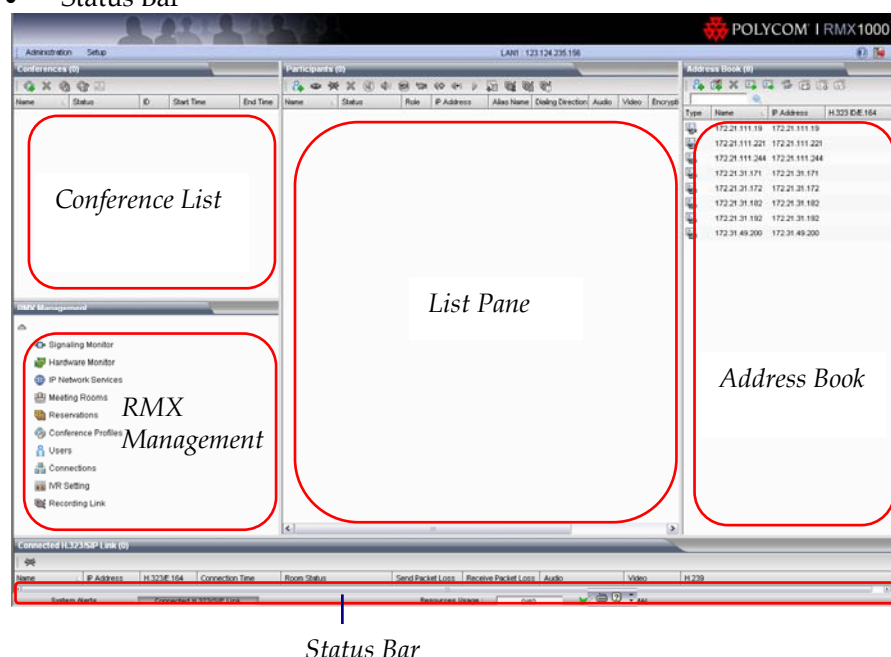

**Figure 3-1** Layout of the Web Interface

## User Rights

You can log into the Web interface as a conference chairperson, an operator, or an administrator.



RMX 1000 can support a maximum of 20 users simultaneously connected to Web UI.

The table below shows the operation abilities of users at different levels when accessing the Web interface of the RMX 1000.

**Table 3-1** List of User Rights

	View		
	Chairperson	Operator	Administrator
Conference List	√	√	√
List Pane	√	√	√
Address Book	√	√	√
Status Bar		√	√
RMX Management Pane		√	√
Conference Alert		√	√
Conference Status		√	√
Configuration Interface		√	√
	System Operations		
	Chairperson	Operator	Administrator
Start Conference	√	√	√
Monitor Conference	√	√	√
Monitor Participant	√	√	√
Solve Basic Problems		√	√
Modify Device Configuration			√



The administrator has all operation rights to the Web interface. Unless otherwise specified, this guide describes the interface operations of an administrator.

## Pane Layout

### Conference List

The *Conferences* list pane shows all the conferences running on the current device and their relevant information, including status, ID, start time and end time. Here you can create, delete, and lock conferences, as well as view conference details. The title bar of the pane indicates the number of the ongoing conferences.

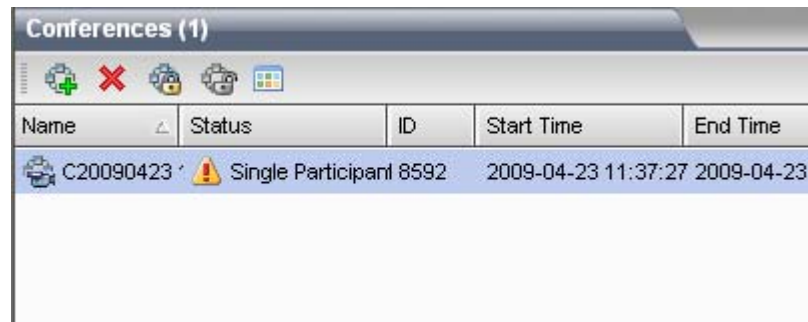

**Figure 3-2** Conference List Pane

If you log in as the conference chairperson, the pane only shows the conferences with no chairperson password. To view the conferences for which a chairperson password is set, enter the password in the **Chairperson Password** box.

### RMX Management

The RMX Management pane lists the menu options for conference configuration, in addition to device maintenance and management. Only users at administrator or operator levels can configure the menu options. After an item is selected in the *RMX Management* pane, the corresponding configuration items will be displayed in the *List* pane.

### List Pane

The *List Pane* displays a list of the participants of the ongoing conference by default. When you click a menu item in the *RMX Management* pane, the List Pane displays the related parameter list. You can view all the property parameters and make specific configurations. The panel title varies with the selected option.

### Status Bar

Located at the bottom of the Web interface, the status bar shows the system alert information, H.323 link status, resources usage and MCU status.

- System Alerts

The indication bar shows problems with the system. If there are problems with the system, this indication bar turns red until all the problems are solved.

Click **System Alerts** on the left part of the *Status Bar* to display the system alert pane. For more information about **System Alerts**, see *System Alerts*.

- **H.323/SIP Link Status**  
This indication bar shows in real time the endpoints connected with the system and relevant information. When an endpoint cannot be connected to the device, **Connected H. 323/SIP Link** on the status bar is highlighted in red. Click this control to open the H.323/SIP link status pane. For more information about H.323/SIP links, see *H.323/SIP Link*.
- **Resources Usage**  
This indication bar shows the number of resources utilized in the system and the number of resources available in the system.

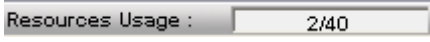
For example,  indicates that 40 resources are available and 2 of them are in use. Click **Resources Usage** to view details about resources usage. For the related description, see *Resources Report*.

- **MCU State**  
The following explains the information displayed in the MCU State area:
  - State: NORMAL- The MCU is functioning normally.
  - State: MINOR - The MCU has a MINOR problem but keeps working.
  - State: MAJOR- The MCU has a MAJOR problem. MCU behavior could be affected and attention is required.

## Address Book

The **Address Book** shows the participant information set on RMX 1000 and the device information stored on the directory server (when the RMX 1000 integrates with a directory server). It enables users to easily add participants listed in the address book to a conference. Here a user can create and delete participants or groups, import and export the address book, etc. For more information about the address book, see Section *Address Book*.

## Common Operations

### List Sorting

All the list items (such as the conference list, participant list and address book list) on the Web interface can be sorted by parameter properties.

Click the desired column header in the list. When a small triangle (▲) appears, you can sort the list in ascending or descending order. After a list is sorted by a column header in ascending (or descending) order, you can click the column header again to sort it in opposite order.

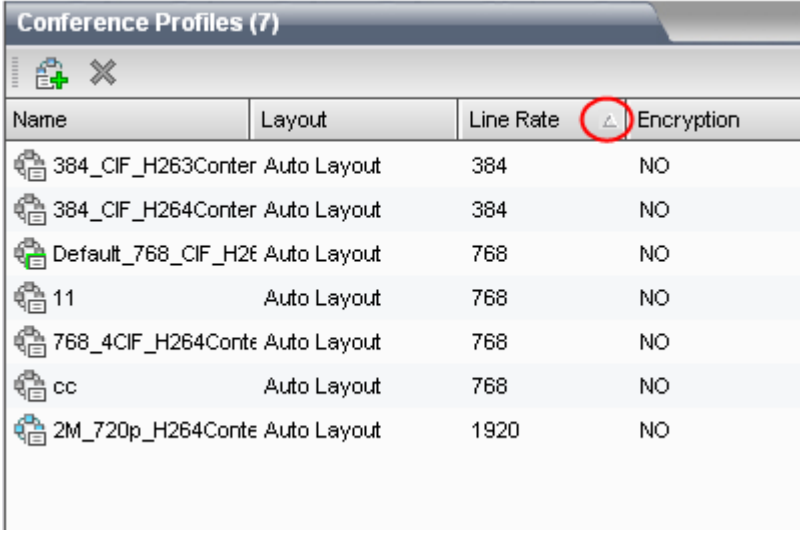

Name	Layout	Line Rate	Encryption
384_CIF_H263Conter	Auto Layout	384	NO
384_CIF_H264Conter	Auto Layout	384	NO
Default_768_CIF_H264	Auto Layout	768	NO
11	Auto Layout	768	NO
768_4CIF_H264Conte	Auto Layout	768	NO
cc	Auto Layout	768	NO
2M_720p_H264Conte	Auto Layout	1920	NO

**Figure 3-3** List Sorting

### Right-click Shortcut Menu

The Web interface provides right-click shortcut menus for common operations such as viewing detailed parameters, creating / deleting items, etc. Alternatively, you can perform these operations by double-clicking the corresponding list items or by using the corresponding buttons on the toolbar of the pane.

### Pane Sizing

Move the mouse pointer to the border of the pane; when the pointer turns into an arrow, drag to size the pane while holding down the left mouse button.

### Confirm/Cancel

To confirm your settings on the parameter configuration interface, click the OK button in the lower part of the interface. To abort your settings, click the Cancel button.



### Shortcut Windows Operations

To enable the user to easily operate RMX 1000, the system utilizes some Windows shortcut keys.

- After you select a target from the conference list, participant list, address book list or another list, you can delete it by pressing the **Delete** key.
- A user can perform standard batch-processing operations by pressing **Ctrl + targets** or **Shift + targets**.



## Starting a Conference

There are several ways to start a conference with the RMX 1000:

- Create an instant conference through the conference list pane of Web interface.
- Directly start a conference using a video endpoint's remote control.
- Dial into a meeting room. A Meeting Room is a conference that is saved in the MCU, without occupying any resources. It remains in passive mode until it is activated by the first participant. For more information about Meeting Rooms, see *Meeting Rooms*.
- Reserve a conference (optional): The reserved conference is stored at the MCU and reserves system resources for the call's specified time. The system automatically convenes the conference according to the reservation time. For more information about conference reservation, see *Reservations*.
- Start a conference in the Personal Conference Manager (PCM) interface. For details, see *Creating a Conference*.

This part describes how to create a conference instantly through the *Conferences* pane and remote control. These two conference types can be established only when the required system resources are available. They will be deleted right after their completion to maximize system resources. A user can view the current available resources in the system through the *Resource Report* page of Web interface so as to better schedule conferences. For details, see *Resources Report*.

### Starting a Conference from the Conferences Pane

To start a conference from the Conferences pane:

- 1 Click the  button in the *Conferences* pane to display the *New Conference - General* interface.

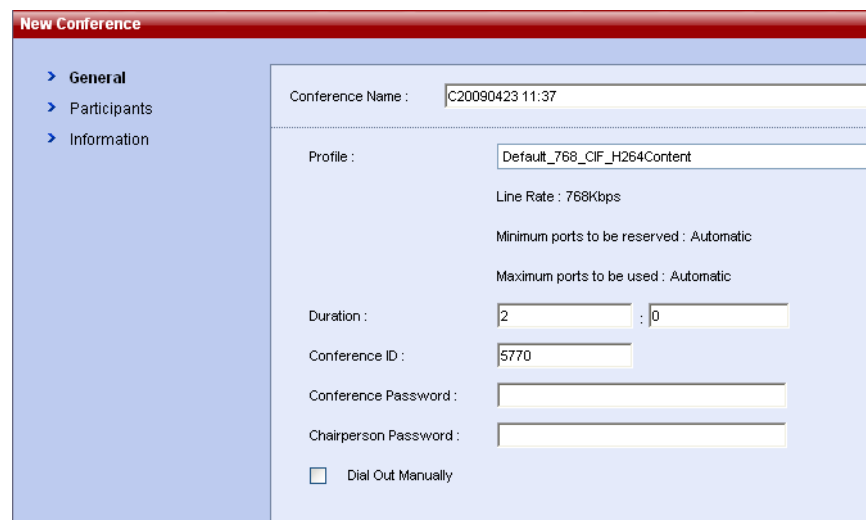

The screenshot shows the 'New Conference' web interface. On the left is a navigation pane with 'General', 'Participants', and 'Information' options. The main area contains the following fields:

- Conference Name: C20090423 11:37
- Profile: Default\_768\_CIF\_H264Content
- Line Rate: 768Kbps
- Minimum ports to be reserved: Automatic
- Maximum ports to be used: Automatic
- Duration: 2 : 0
- Conference ID: 5770
- Conference Password: (empty field)
- Chairperson Password: (empty field)
- Dial Out Manually

**Figure 3-4** New Conference Page

The *New Conference* page displays the default conference name, duration, profile of conference parameters, and the conference ID automatically

allocated by the system. These options are configurable, but none of these settings need to be modified to start a conference.

The conference chairperson or organizer should inform other participants of the conference ID used for the conference, so that they can dial in.

If necessary, set the basic parameters for the conference and add participants or related supplementary information as needed. For more information of configuration, see *Creating a Meeting Room*.

After completing the setup, click **OK**. After that, the conference list shows that the new conference is running. If no participant is specified for the conference, the status is displayed as  Empty, until a participant dials in to the conference.

## Starting a Conference Using the Remote Control – Conference on Demand

A user can enter the call character string that contains the conference ID through the remote control, and directly start a new conference on RMX 1000. The dialing string can vary according to the user's endpoint type, whether to set the conference password and chairperson password, and whether to invite other participants.

### H.323 Endpoint

For an H.323 endpoint, if the endpoint has been registered to the same gatekeeper as RMX 1000, the dial-in number consists of the E.164 prefix of RMX 1000 and conference information (such as the conference ID, conference password, chairperson password and participant address) in the format below:

**<RMX 1000 E.164 prefix>[Conference ID][##Conference password][##Chairperson password][\*Participant's E.164 prefix]**

Here, the character in the <> symbol is mandatory, and that in [ ] is optional.

**For example:**

RMX 1000 E.164 prefix: 925

ID of the conference to be created: 1001

The table below shows the strings dialed by the endpoint under different scenarios:

**Table 3-2** Dial-in String Rule for H.323 Endpoints - Registered to GK

Scenario	Dial-in String
Create this conference	9251001
Create this conference and set: Conference password: 1111 Chairperson password: 2222	9251001##1111##2222
Create this conference and invite: Participant 1 - E.164: 123 Participant 2 - E.164: 321	9251001*123*321

Scenario	Dial-in String
Create this conference, set the above passwords, and invite the above participants	9251001##1111##2222*123*321

If the gatekeeper is not configured on the network, the format of the dial-in string is as follows:

**<RMX 1000 IP address>[##Conference ID][##Conference password][##Chairperson password][\*Participant's IP address]**

Here, the character in the <> symbol is mandatory, and that in [ ] is optional.

**For example:**

RMX 1000 IP address: 172.22.30.40

ID of the conference to be created: 1001

The table below shows the strings dialed by the endpoint under different scenarios:

**Table 3-3** Dial-in String Rule for H.323 Endpoints - Unregistered to GK

Scenario	Dial-in String
Create this conference	172.22.30.40##1001
Create this conference and set: Conference password: 1111 Chairperson password: 2222	172.22.30.40##1001##1111##2222
Create this conference and invite: Participant 1 - IP address: 172.22.30.1 Participant 2 - IP address: 172.22.30.2	172.22.30.40##1001*172.22.30.1*172.22.30.2
Create this conference, set the above passwords, and invite the above participants	172.22.30.40##1001##1111##2222*172.22.30.1*172.22.30.2

**SIP Endpoint**

For an SIP endpoint, if the endpoint has been registered to the same SIP server as RMX 1000, the dial-in number of SIP endpoint consists of the static route domain name of RMX 1000 and conference information (such as the conference ID, conference password, chairperson password and participant address) in the format below:

**[Conference ID][\$\$Conference password][\$\$Chairperson password][\*Participant's TEL URI/SIP URI]@<RMX 1000 static route domain name>**

Here, the character in the <> symbol is mandatory, and that in [ ] is optional.

**For example:**

RMX 1000 static route domain name: polycom.com

ID of the conference to be created: 1001

The table below shows the strings dialed by the endpoint under different scenarios:

**Table 3-4** Dial-in String Rule for SIP Endpoints - Registered to Server

Scenario	Dial-in String
Create this conference	1001@polycom.com
Create this conference and set: Conference password: 1111 Chairperson password: 2222	1001\$\$1111\$\$2222@polycom.com
Create this conference and invite: Participant 1 - TEL URI/E.164: 123 Participant 2 - TEL URI/E.164: 321	1001*123*321@polycom.com
Create this conference, set the above passwords, and invite the above participants	1001\$\$1111\$\$2222*123*321@polycom.com

If the SIP server is not configured on the network, the format of the dial-in string is as follows:

**<Conference ID>[\$\$Conference password][\$\$Chairperson password][\*Participant's IP address or FQDN]<RMX 1000 IP address>**

Here, the character in the <> symbol is mandatory, and that in [ ] is optional.

**For example:**

RMX 1000 IP address: 172.22.30.40

ID of the conference to be created: 1001

The table below shows the strings dialed by the endpoint under different scenarios:

**Table 3-5** Dial-in String Rule for SIP Endpoints – Unregistered to Server

Scenario	Dial-in String
Create this conference	1001@172.22.30.40
Create this conference and set: Conference password: 1111 Chairperson password: 2222	1001\$\$1111\$\$2222@172.22.30.40
Create this conference and invite: Participant 1 - IP address: 172.22.30.1 Participant 2 - IP address: 172.22.30.2	1001*172.22.30.1*172.22.30.2@ 172.22.30.40
Create this conference, set the above passwords, and invite the above participants	1001\$\$1111\$\$2222*172.22.30.1*172.22.30.2@ 172.22.30.40

## Dialing method between H.323 and SIP Participants

The RMX system can work as a gateway to enable the H.323 or SIP participants inviting the SIP or H.323 participants when creating a conference.

If the GK and SIP server are not configured on the network, dialing is executed in the same way as for inviting the same IP type endpoint. For dialing strings please refer to the previous section.

If the RMX 1000 and the endpoint are registered with the GK or SIP server, the format of the dial-in string is as follows:

Dialing Direction	Dial-in String
H.323->SIP	<p><b>&lt;RMX 1000 E.164 prefix&gt;[Conference ID][##Conference password][##Chairperson password]&lt;* SIP participant's TEL URI&gt;</b></p> <p>Here, the character in the &lt;&gt; symbol is mandatory, and that in [ ] is optional.</p> <p><b>Note:</b> For an H.323 conference creator to invite a SIP participant, if the H.323 endpoint has been registered to the same gatekeeper as RMX 1000, the SIP endpoint needs to register the SIP server with a numeric URI and the RMX 1000 should also register the same SIP server.</p>
SIP->H.323	<p><b>[Conference ID][\$\$Conference password][\$\$Chairperson password]&lt;* H.323 participant's E.164 prefix&gt;@&lt;RMX 1000 static route domain name&gt;</b></p> <p>Here, the character in the &lt;&gt; symbol is mandatory, and that in [ ] is optional.</p> <p><b>Note:</b> For an SIP conference creator to invite an H.323 participant, if the SIP endpoint has been registered to the same SIP server as RMX 1000, both the H.323 endpoint and the RMX 1000 need to register the same gatekeeper.</p>

In the gateway scenario, the user can create a conference between an H.323 participant and a SIP participant as a point-to-point call through the procedures below:

- 1 Select the **Terminate the call when last participant remains** option in the default profile and keep the default idle time value (0). For more information about conference profile, please see *Defining a Conference Profile*.
- 2 Dial [RMX Prefix]\*[another participant's E.164 or SIP URI]

In that way, when one participant disconnects, the other participant will be disconnected automatically like in a phone call.



- Conference ID is not mandatory. If the user only dial the RMX 1000 E.164/IP plus \*participant's E.164/SIP URI/IP, a conference will be created with a random NID.
- The conference ID the user enters for creating a new conference must be unique - different from existing conference IDs.
- If only one password is entered, it will be defined as a chairperson password. In this case, there won't be a conference password and the user will receive the chairperson privilege.
- The conference password and chairperson password must be different. If a user enters the same password for both, the call will be rejected.

## Connecting to a Conference – Dialing Methods

To connect an endpoint to an ongoing conference or meeting room, you can use one of the dialing methods below:

- Dial the IP address of the RMX 1000 system through the remote control to connect the RMX 1000. If the system is registered to a gatekeeper or SIP server, dial the E.164 prefix or SIP URL to connect to the system, and then use the remote control to select a conference in the PCM interface to join. For details, see *Entering an Existing Conference*.
- Directly dial in to the conference using the remote control. For details, see the following sections. In this way, the user must obtain the conference ID and password (if the conference password or chairperson password is set) first.

### H.323 Endpoint

For an H.323 endpoint, if the endpoint has been registered to the same gatekeeper as RMX 1000, the dial-in number consists of the E.164 prefix of RMX 1000 and conference ID. If the conference to be dialed in is set with a password, you need to add "##Conference password or chairperson password".

**For example:**

RMX 1000 E.164 alias: 925

ID of the conference to be dialed in: 1001

Then, the endpoint dials 9251001

If the conference to be dialed in is set with the conference password 1111 and chairperson password 2222

Then, the regular participant dials 9251001##1111

The conference chairperson dials 9251001##2222

If the gatekeeper is not configured on the network, the dial-in string consists of the IP address of RMX 1000 and conference ID, separated with ##. If the conference to be dialed in is set with a password, you need to add ##Conference password or chairperson password.

**For example:**

RMX 1000 IP address: 172.22.30.40

ID of the conference to be dialed in: 1001

Then, the endpoint dials 172.22.30.40##1001

If the conference to be dialed in is set with the conference password 1111 and chairperson password 2222

Then, the regular participant dials 172.22.30.40##1001##1111

The conference chairperson dials 172.22.30.40##1001##2222

### SIP Endpoint

For the SIP endpoint, you can use the remote control to directly dial in to the conference only when RMX 1000 and endpoint are registered to the same SIP

server. If the endpoint is registered to another SIP server, you can only first call the SIP URL of RMX 1000 to set up a connection, and then access the conference by entering the conference ID as IVR service prompted or through the PCM interface. The dial-in number of SIP endpoint consists of the static route domain name of RMX 1000 and conference ID in the format below:

**Conference ID [\$\$Conference password or chairperson password]@RMX 1000 static route domain name**

Here, the character in [ ] is optional. It needs to be entered when the conference is set with a conference password or chairperson password.

**For example:**

RMX 1000 static route domain name: polycom.com

ID of the conference to be dialed in: 1001

Then, the endpoint dials 1001@ polycom.com

If the conference to be dialed in is set with the conference password 1111 and chairperson password 2222

Then, the regular user dials 1001\$\$1111@ polycom.com

The conference chairperson dials 1001\$\$2222@ polycom.com. If RMX 1000 is not registered to an SIP server, the dial-in number consists of the IP address of RMX 1000 or FQDN and conference ID in the format below:

**Conference ID [\$\$Conference password or chairperson password]@RMX 1000 IP address or FQDN**

Here, the character in [ ] is optional. It needs to be entered when the conference is set with a conference password or chairperson password.

**For example:**

RMX 1000 IP address: 172.22.30.40

ID of the conference to be dialed in: 1001

Then, the endpoint dials 1001@172.22.30.40

If the conference to be dialed in is set with the conference password 1111 and chairperson password 2222

Then, the regular user dials 1001\$\$1111@172.22.30.40

The conference chairperson dials 1001\$\$2222@172.22.30.40



If the conference ID the user entered does not exist, RMX 1000 will create a new conference with this conference ID. For more information, see *Starting a Conference Using the Remote Control*.

---

# Conference Profiles

A conference profile is used to pre-define the basic parameters for conference scheduling, such as the bandwidth, encryption, and video quality. All conferences will be created on the basis of conference profiles. By saving conference profiles on the RMX 1000, users can conveniently and rapidly schedule new conferences without performing repeated configurations. The following parameters generally decide the video conference quality.

- Bit Rate – The transmission rate of the audio and video streams. The higher this value is, the better the displayed video quality.
- Video Protocol, Video Format, and Frame Rate – These parameters define the quality of the video picture. When an endpoint is connected to the conference, it will select a video capability based on the video parameters set for the conference. For example, if the video protocol for the conference is H.264, an endpoint that supports the H.264 protocol will select H.264 for video coding when it connects to this conference.

The following features are commonly used to define a conference:

- H.239 Dual-stream – An H. 239 compliant endpoint can simultaneously send and receive two channels of conference video streams: dynamic conference video and PC screen contents.
- Encryption – The system provides AES 128-based multimedia encryption to strengthen conference security.

To set a conference profile, click **Conference Profiles** in the *RMX Management* pane. The list pane shows the profiles saved on the current device and their summaries.



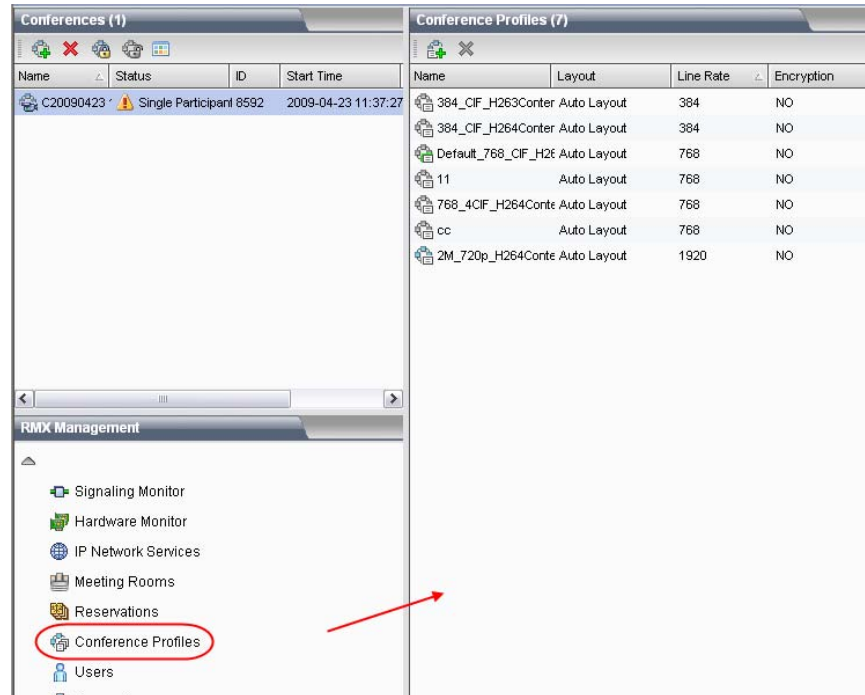



Figure 4-1 Conference Profile List

RMX 1000 is provided with default built-in conference profiles so that users can create conferences easily.

Table 4-1 Default Conference Profiles

Profile Name	Parameter
Default_768_CIF_H264Content (Default Profile)	H.264 dual-stream
768_4CIF_H264Content	4CIF H.264, H.264 dual-stream
384_CIF_H264Content	384 CIF, H.264 dual-stream
384_CIF_H263Content	384 CIF, H.263 dual-stream
2M_720p_H264Content (Appears only if the H.264 720p option is activated.)	2M 720p, H.264 dual-stream

## Defining a Conference Profile

To create a conference profile, click the  button in the *Conference Profile* list pane or right-click in the blank area in the pane, and then click **New Profile**. The *New Profile* interface appears. The RMX 1000 fills in default settings. For basic operations, you only need to define the display name of the profile. To configure parameters, see the description below.

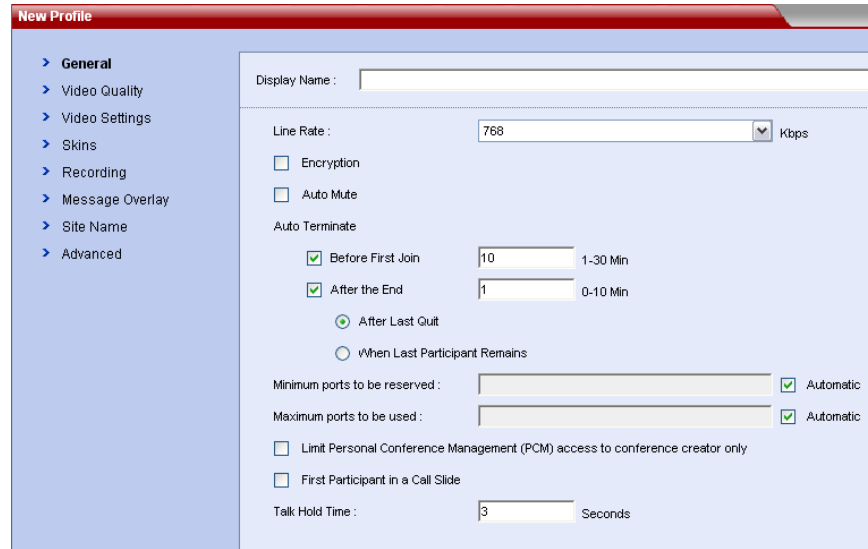

Figure 4-2 New Profile Settings

## General Settings

On the *New Profile* page, click the **General** tab to display the interface for configuring general parameters. The table below explains the detailed meanings of these parameters.

Table 4-4 General Parameters

Parameter	Description
<i>Display Name</i>	Enter a unique name to identify this profile. <b>Note:</b> This is the only mandatory parameter when you create a new profile.
<i>Line Rate</i>	Select the conference line rate. Line rate indicates the rate that integrates video, audio, and data contents.
<i>Encryption</i>	Set whether to enable the AES encryption function for this profile. <b>Note:</b> <ul style="list-style-type: none"> <li>▪ The RMX 1000 version for some geographic areas may not allow for the encryption option.</li> <li>▪ Encryption is an optional function of RMX 1000. This function is only available after you purchase its license and activate this function. To obtain this function, please contact your supplier.</li> </ul>
<i>Auto Mute</i>	If this check box is selected, after an endpoint dials into the conference, the RMX 1000 will automatically mute it.

Parameter	Description
<i>Auto Terminate</i>	<p>If this check box is selected, the system will automatically terminate the conference when any of the following conditions is satisfied:</p> <ul style="list-style-type: none"> <li>▪ Before First Join - No participant joined within the predefined period since the conference started. The default idle time is 10 minutes.</li> <li>▪ After Last Quit - All participants have left the conference, and the idle period has reached the predefined time. The default idle time is 1 minute.</li> <li>▪ When Last Participant Remains - Only one participant remained in the conference, and that period has reached the predefined time. The default idle time is 1 minute.</li> </ul>
<i>Minimum ports to be reserved</i>	<p><b>Auto</b> is selected by default, indicating that the system will decide the number of allowed video participants according to the number of actual idle resources when the conference is created. When <b>Auto</b> is not selected, you can specify the minimum number of video participants so that the system can reserve the appropriate resources for this conference when it is being held.</p>
<i>Maximum ports to be used</i>	<p><b>Auto</b> is selected by default, indicating that the system will decide the number of allowed video participants according to the number of actual idle resources when the conference is created. When <b>Auto</b> is not selected, you can set the maximum number of video participants. You can add the maximum number of video participants set here when you hold a conference using this template.</p>
<i>Limit Personal Conference Management (PCM) access to conference creator only</i>	<p>When this check box is selected, only the participant who created this conference can view the PCM menu and control the conference.</p>
<i>First Participant in a Call Slide</i>	<p>With this option selected, the image of the first joined participant will not be shown at his endpoint. Instead, the endpoint of the first participant will display the default idle images dispatched from the system when this participant enters the conference.</p>
<i>Talk Hold Time</i>	<p>When the period a participant speaks reaches the predefined time, this participant will become the primary speaker. Under different video modes, the speaker's image may be displayed in full screens on other participants' screens or switched to the largest window in the screen layout.</p>

## Video Quality

To set the video quality parameters for the conference, click the **Video Quality** tab. A user can adjust the quality parameters of the site image during the conference, or define the quality parameters of the second channel video when sharing the dual-stream contents.

**Figure 4-3** Video Quality Setup Page

Depending on the user's selection in *People Video Definition*, the profile can be defined as two types of conference modes: the Continuous Presence (CP) conference and the video switching conference.

- **CP conference:** The endpoint screen can simultaneously display the images of multiple sites. A user can also choose a preferred screen layout. However, this mode occupies more MCU video resources.
- **Video switching conference:** The system only forwards the video stream without encoding or decoding. Therefore, this mode does not utilize the MCU video resources, and more conferences can be held. In the video switching conference, all the participants' endpoints use the same bandwidth and video capability, and can only display one site at a time. A user can use the voice activation feature to switch to see each conference site. The maximum number of video switching conferences supported by the system is equal to the number of participant connection resources available and is not related to the video capability of an endpoint. The video switching conference has the following limitations:
  - Only one type of conference screen layout is supported ■
  - Only the lecture mode is supported.
  - Settings for the conference skin and **Message Overlay** are not available.
  - Site name setting during a conference is not allowed.
  - The PCM menu is not available.

## Defining People Video Quality

To define the video quality of CP conference:

As described in the table below, select the highest resolution of CP conference in the *People Video Definition* field.

**Table 4-5** *People Video Definition*

Parameter	Description
<i>Up to H.264, CIF/SIF</i>	It is used for the screen display of ordinary quality. The conference video can be best encoded/decoded with the H.264 protocol and displayed with the CIF/SIF resolution, requesting the lowest bandwidth requirement and occupying the minimum system resources. In the conference, each endpoint only occupies one video connection resource.
<i>Up to H.263, 4CIF/4SIF, 15FPS</i>	It is used for the screen display of high quality. The conference video is encoded / decoded with the H.263 protocol and displayed with the 4CIF/4SIF resolution and 15FPS frequency, requesting a higher bandwidth. In the conference, each endpoint only occupies one video connection resource.
<i>Up to H.264, 4CIF/4SIF</i>	It is used for the screen display of higher quality. The conference video is encoded/decoded with the H.264 protocol and displayed with the 4CIF/4SIF resolution. The endpoint must support the H.264 protocol and the bandwidth cannot be lower than 256Kbps. Each endpoint in the conference utilizes 2 video connection resources.
<i>(Optional with keycode) Up to H.264, 720P (Common Layout)</i>	<p>The conference video can be best encoded/decoded with the H.264 protocol and displayed with 1280x720 (720p) HD resolution, utilizing more system resources. The conference under this mode has the following restrictions:</p> <ul style="list-style-type: none"> <li>▪ The endpoint must support the H.264 protocol and 720p resolution, and the bandwidth cannot be lower than 832Kbps. Otherwise, the conference video will be degraded to the 4CIF/CIF resolution display or H.263 coding depending on the capability of the endpoint that joins in the conference.</li> <li>▪ It supports only the Same Layout video mode, and the same video layout is displayed for all the conference sites.</li> <li>▪ When there is no other CP conference concurred, the system supports convening a maximum of 5 720p conferences at the same time on condition that each conference only has two participants and they all support 720p.</li> <li>▪ When a 720p conference is ongoing, the screen of the participant's endpoint displays only the conference video. For the PCM related information, see <i>Personal Conference Manager (PCM)</i>.</li> </ul> <p><b>Note:</b> <i>Up to H.264, 720P</i> is an optional function of the RMX 1000 and will not be available until a license is purchased. If the license for this function is not activated, the device does not display the related options. To obtain this function, please contact your supplier.</p>

To define the video quality of video switching conference:

Select **Video Switching Highest Common** from the *People Video Definition* field.

Each endpoint under this mode occupies only one video connection resource,

and the conference video can be displayed with the best HD resolution of 1280x720 (720p). However, all the endpoints must support the H.264 protocol and 720p resolution, and the bandwidth cannot be lower than 832Kbps, or else the display of conference video will be, depending on the capability of the participant's endpoint, degraded to the resolution of 4CIF or CIF, or H.263 code.



The RMX supports a maximum of 20 video resources and 20 audio resources. The number of connection resources supported by the device in the actual conference depends on the number of resources purchased by the user.

### Defining Content Video Quality

When the endpoint sends dual streams, the RMX 1000 system applies different encoding and decoding policies to the people video stream and content video stream. See the table below, which provides the video parameters for setting the second channel of content image.

**Table 4-8** Video Quality Parameters – Second-channel Video Dual-stream Definition

Parameter	Description
<i>Content Setting</i>	Set the video protocol used for the dual-stream video. You can select the H.264 or H.263 coding/decoding algorithm based on the endpoint capability and network bandwidth. When None is selected, it indicates dual streams are not enabled. <b>Note:</b> If this setting is H.264, when an endpoint that only supports H.263 protocol joins in the conference, an H.264 endpoint that originally sent dual streams will terminate sending dual streams and resend them using the H.263 protocol.
<i>H.239 Setting</i>	The H.239 protocol is used to send dual streams. You can select three kinds of video quality as needed: <ul style="list-style-type: none"> <li>▪ Graphics: For the standard video display</li> <li>▪ High-resolution graphics: For the graphic detail display of high quality broader bandwidth is required.</li> <li>▪ Live Video: For full-motion of dynamic video display. The broadest bandwidth is required.</li> </ul>
<i>Send Content to Legacy Endpoints</i>	When this option is enabled, legacy endpoints that do not support the H.239 protocol will still be able to view Content in the conference. However, the Content video will be sent to these endpoints <i>instead of</i> the People video when Content is introduced to the conference. Legacy endpoints will not be able to share content – they will only be able to view. Modern endpoints which support H.239 will continue to view dual streams (People and Content simultaneously) and be able to share content.

## Video Settings

To set the screen layout of conference on the endpoint screen, click the **Video Settings** tab on the *New Profile* interface.

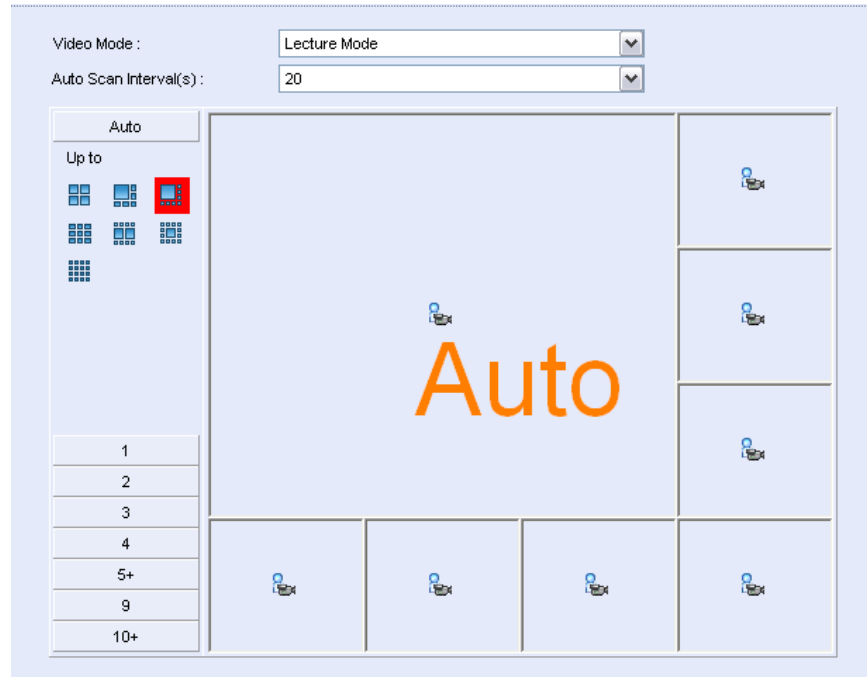

Figure 4-4 Video Settings



In the *Video Mode* drop-down menu, you can set the following video modes for conference:

- **Lecture Mode:** All the conference participants view the selected lecturer in full screen, and the lecturer's endpoint will display the screens of other sites in accordance with the layout set here. A user can specify a lecturer after the conference is initiated. For details, see the lecture mode description in Section *Changing Conference layout*.
- **Same Layout:** All the participants' endpoints in the conference will display the same screen image according to the layout set here. This setting will allow sites to see their own loopback images, which are normally not included as part of the layout.
- **Conference Layout:** Each participant's endpoint in the conference can display a different screen layout. In this mode, the operator can enter the participant parameter page through the Web interface, and perform personalized settings for the screen layout displayed on the video endpoint of each site. For details, see *Setting Conference Layout for Participant's Endpoint*. While, the participant can define a personal layout by operating the PCM interface via the remote control. For details, see *Click & View*.











Based on the selected video mode, a user can set to automatically select the screen layout according to the number of added participants or specify a fixed screen layout:

**To set automatic layout:**

- 1 Click **Auto** at the left part of the layout setting area to display the automatic screen layout pane.
- 2 Select a maximum screen layout so that the conference site displays at most the number of multi-screen windows set here. In this mode:

- When the number of participants is smaller than or equal to the set number of multi-screens, the system displays the multi-screen image according to the actual number of participants and in line with the default rule. The table below shows the default rule.
- When the number of participants is greater than the set number of multi-screens, the system uses the voice activation feature, and switches to display the first participants who speak loudest with the largest multi-screen layout selected here. If the number of participants is greater than 4 and the maximum selection is , the system will display the first four participants who speak loudest using the  layout.

**Table 4-9** Default Rule of Automatic Layout

Number of Participants	Multi-screen Layout
1	
2	
3-4	
5-6	
7-8	
9	
10	
11-13	
14-16	
16+	

**To specify a fixed layout:**

- 1 Click at the left part of layout setting area the number of multi-screen windows to be displayed to expand the corresponding layout pane.
- 2 Select a screen layout so that the conference site displays the participant's image always according to the layout selected here.

## Conference Skin Settings

Click the **Skins** tab in the *New Profile* interface to enter the interface for skin settings. Here, you can define the background picture and outline color of the CP image, and browse the skin effect in the browsing area at the lower part of the interface.



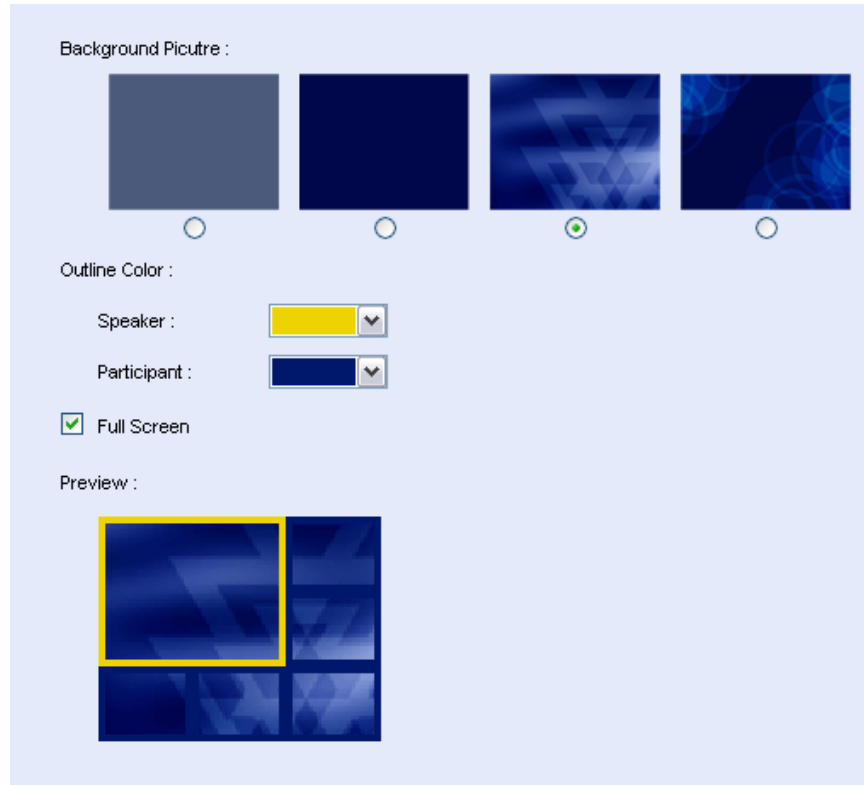

Figure 4-5 Meeting Room Parameter Setup Interface

Customize settings for the conference skin by referring to the table below:

Table 4-11 Parameter Description of Conference Skin

Parameter	Description
<i>Background Picture</i>	Select the background picture for the conference screen.
<i>Outline Color</i>	A user can respectively set the outline colors of screens for the conference lecturer and regular participant.
<i>Full Screen</i>	When this option is selected, multi-screens will extend the full screen, without spacing.



If the conference is set to a video switching conference, a user cannot set conference skin on this interface.

## Conference Recording

RMX 1000 can work with Polycom RSS 2000 recording server to record conferences. Click the **Recording** tab on the *New Profile* interface to enter the related information and set the recording parameters.

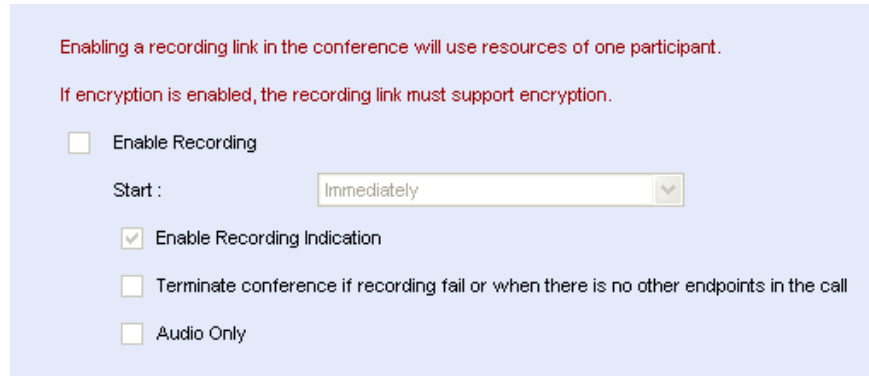

**Figure 4-6** Recording Parameter Setup Interface

The table below explains the configuration parameters.

**Table 4-12** Conference Recording Configuration

Parameter	Description
<i>Enable Recording</i>	If an RSS 2000 is available on your network, you can select this option to enable the recording function.
<i>Start</i>	Select the start time of the conference recording: <ul style="list-style-type: none"> <li>▪ Immediately – The recording automatically starts immediately after the first participant joins the conference.</li> <li>▪ Upon Request – The operator or chairperson starts the recording manually. After this option is selected, the recording can be manually started through the Web interface or DTMF function. For more information, see <i>Recording Control</i>.</li> </ul>
<i>Enable Recording Indication</i>	If this option is selected, the endpoint screen displays the recording indicator icon to inform participants that the conference is being recorded:  <b>Note:</b> Recording indication is not supported in video switching conference and HD 720p conference.
<i>Terminate conference if recording fail ...</i>	If this option is selected, the system will terminate the conference when the recording fails or there is no endpoint in the lobby.
<i>Audio Only</i>	If this option is selected, only the audio will be recorded.



- The recording parameters can be set here only after the IP address of the RSS 2000 is configured on the Recording Link interface. For how to set Recording Link, see Recording Setup.
- The Recording Link occupies one conference resource.
- If the encryption function is enabled in the **Conference Profiles->General** interface, recording will succeed only when the RSS 2000 also supports encryption.

## Message Overlay

When a message needs to be sent to all the participants in a conference, you can set the message overlay of conference to be displayed on all participants' endpoint screens.

Click the **Message Overlay** tab on the *New Profile* interface to set the message overlay parameters.

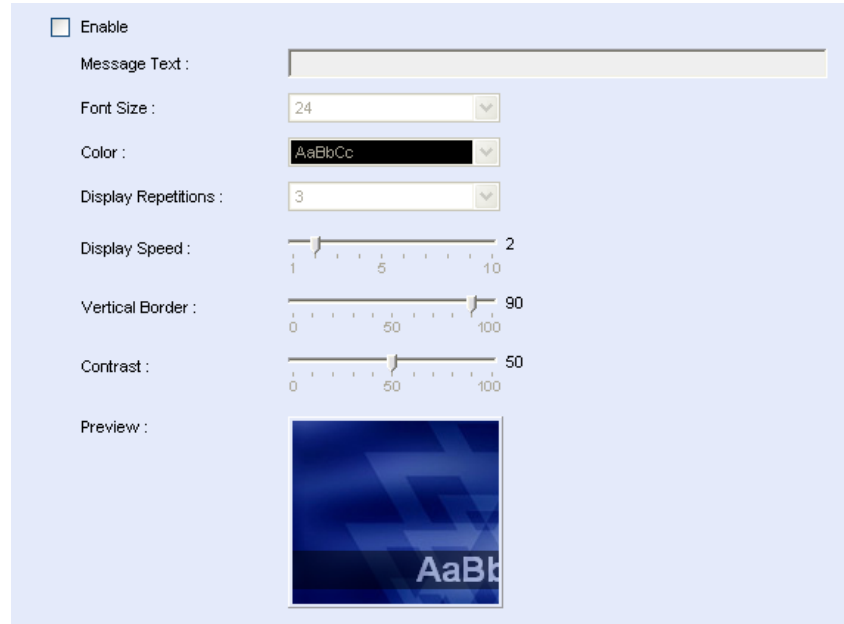

**Figure 4-7** Message Overlay Setting Interface

Set the message overlay with reference to the table below:

**Table 4-13** Description of Message Overlay Setting Parameters

Parameter	Description
<i>Enable</i>	Select this option to enable message overlay. Then you can set other parameters.
<i>Message Text</i>	Enter the content to be displayed.
<i>Font Size</i>	Set the font size of the message overlay.
<i>Color</i>	Set the color-matching scheme for the message overlay font and background.
<i>Display Repetitions</i>	Move the slider to set the display times of the message overlay.
<i>Display Speed</i>	Move the slider to set the display speed of the message overlay.
<i>Vertical Border</i>	Move the slider to set the vertical boarder of the message overlay.
<i>Contrast</i>	Move the slider to set the contrast of the message overlay.

## Site Name

A user can set the site name (endpoint name), so as to label each site when viewed onscreen. The site name displayed for each connected participant comes from the system name configured within the endpoint.

Click the **Site Name** tab on the *New Profile* interface to set the site name parameters.

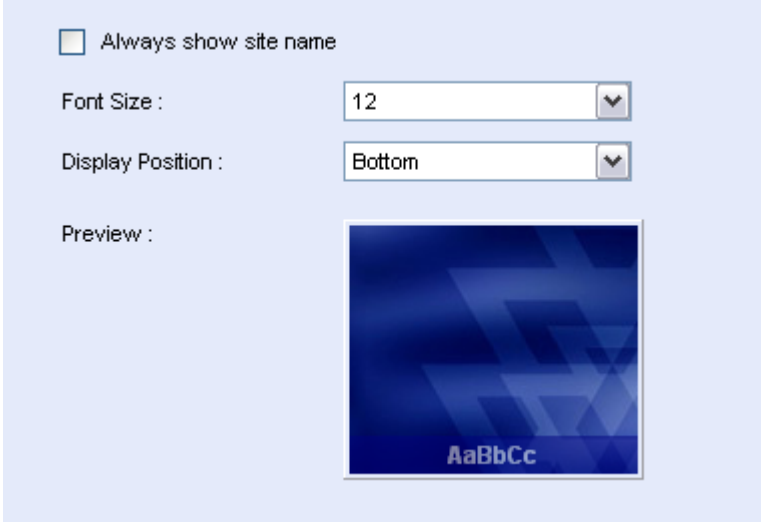

**Figure 4-8** Site Name Setting Interface

Here, you can specify the displayed font size and position for the site name. If **Always show site name** is selected, the name of each site will be always displayed during the conference.

## Advanced Options

A user can set advanced options in the conference profile to fine-tune video and audio quality.

To set advanced options, click **Advanced Options** in the *New Profile* interface.

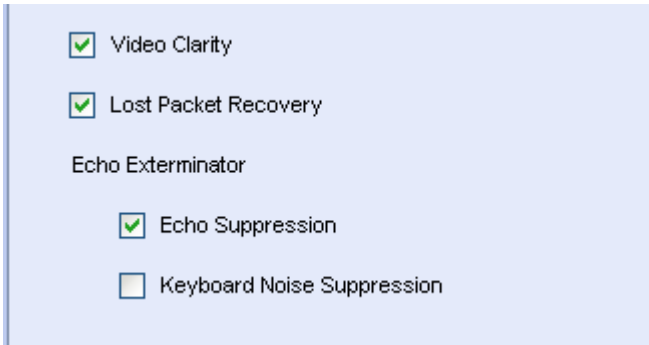

**Figure 4-9** Advanced Options Setting Interface

The table below describes the related parameters.

**Table 4-14** Parameter Description of Advanced Options

Parameter	Description
<i>Video Clarity</i>	This option is enabled by default. It is used to improve the clarity of video received from an endpoint which has low bandwidth and/or low resolution.
<i>Lost Packet Recovery</i>	Lost Packet Recovery (LPR) is an algorithm designed to protect IP video calls against the impact of network packet loss. This option is enabled by default. In case of packet loss during network transmission, the packet recovery mechanism will be automatically activated if the endpoint experiencing packet loss also supports the LPR protocol. This function can effectively improve the decreased video quality caused by packet loss.
<i>Echo Suppression</i>	This option is enabled by default. It is used to prevent the sound of near site echoing being played to the far site(s).
<i>Keyboard Noise Suppression</i>	This option is disabled by default. It specifies whether the system mutes audio sent to the far site when keyboard tapping sounds are detected at the near site(s).

## Modifying a Profile

To modify a saved profile, right-click in the *Profile* list, and then click **Profile Properties** to modify its properties.

## Deleting a Profile

To delete an existing profile, select it in the *Profile* list, and then click . Alternatively, right-click the profile to be deleted and then click **Delete Profile**.



A profile in use cannot be modified or deleted.

## Setting a Default Profile

After a default profile is set, the endpoint will use it when creating a conference directly through the remote control. In addition, when a user creates a meeting room, reserves a conference or holds an instant conference via the Web interface, the default profile will be used unless otherwise specified.

To set a default profile, right-click the profile to be defined in the *Profile* list, and then click **Set as Default**. After that, the icon of the profile becomes .



A profile with the AES encryption function enabled cannot be set as the default profile.

# Recording Link

The RMX 1000 supports the recording link function. It can work with the RSS 2000 to record conference content. After the recording setup is completed, when the conference starts, the RMX 1000 will first call the participants in the participant list, and then call the configured RSS 2000 to record the conference. The recording link is displayed in the List pane as a regular participant, thereby enabling users to view and control the recording status easily.

To record a conference running on RMX 1000 through RSS 2000, configure the related parameters according to the procedure below:

- 1 Configure the information of RSS 2000 to be connected in the *Recording Link* interface. For details, see the text below.
- 2 The profile used for the conference has enabled the recording function. For details, refer to *Conference Recording*.

## Recording Setup

In the *RMX Management* pane, click **Recording Link**. The *Recording Link* interface appears in the list pane located on the right side. Here you can view the IP address and alias configured for the RSS 2000.

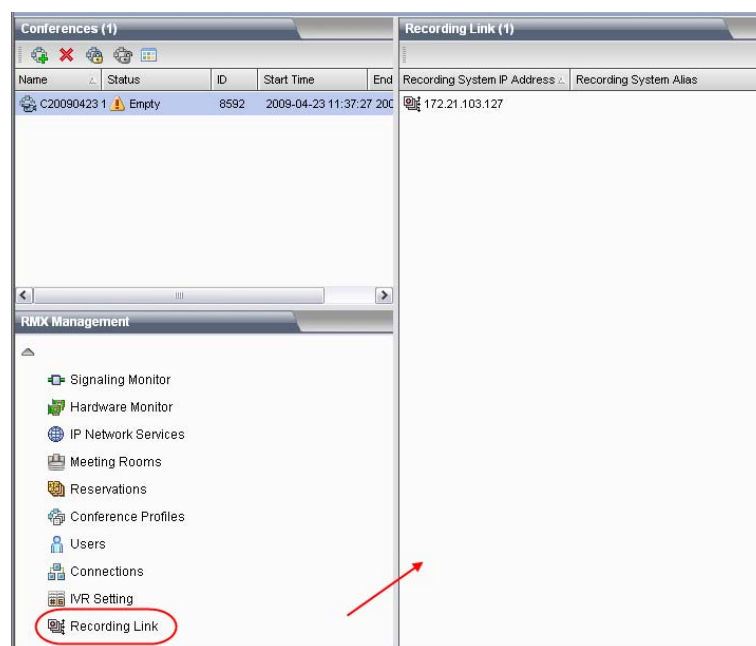

Figure 5-1 Recording Link

Right-click the default empty link or configured RSS IP address in the interface, and then click **Properties** to display the *Recording Link -> General* interface.

## General Settings

**Figure 5-2** Recording Link - General

The table below explains the detailed meanings of these parameters.

**Table 5-1** Parameter Description for Recording Link - General

Parameter	Description
<i>RSS 2000 IP Address</i>	Enter the IP address of the RSS 2000 to be connected. This item is optional if an alias is set in the <i>Alias</i> check box below.
<i>RSS 2000 Alias</i>	Enter the E.164 number or H.323 alias of the RSS 2000 in accordance with the selected alias type. This item is optional if the IP address of the RSS 2000 is set. <b>Note:</b> If the alias is used for recording call, both RMX 1000 and RSS 2000 need to be registered to the same gatekeeper.
<i>Alias Type</i>	Set the alias type of the RSS 2000: H.323 or E.164.

## DTMF Code Setting

To set the recording control operations and rights for use by connected endpoints, click the **DTMF Codes** tab.

Name	DTMF Code	Permissions
Pause Recording	*1	Everyone
Start Recording	*2	Everyone
Stop Recording	*3	Everyone

**Figure 5-3** Recording Link - DTMF Codes

The table below explains the detailed meanings of these parameters.

**Table 5-2** Parameter Description for Recording Link - DTMF Codes

Parameter	Description
Name	Name of the recording operation
DTMF Code	Set the remote control key combination used to perform the operation. The default numbers can be customized. For example, the default DTMF code for the Start Recording command is *2, you can press the keys *2 to start conference recording. <b>Note:</b> Before using the DTMF command, enable the DTMF function of the endpoint according to that endpoint's instructions.
Permissions	Set the rights of using DTMF codes. Chairperson indicates that the DTMF is available to the conference chairperson only; Everyone indicates that the DTMF is available to all participants.

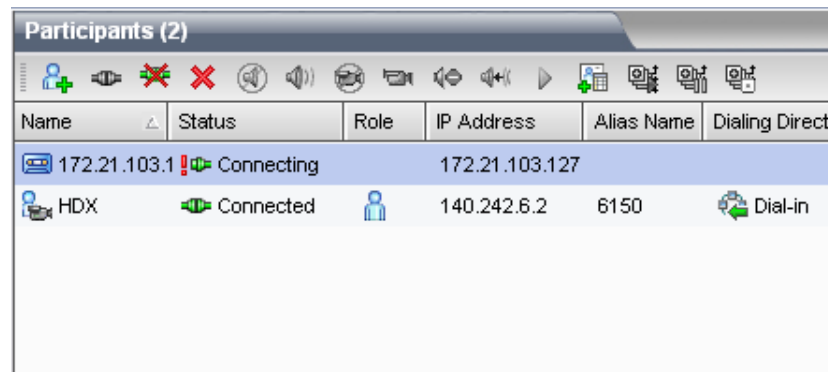

## Recording Control

When a conference is going on, you can view and control the status of the configured recording link. In the *Conferences* list pane, select the desired conference. Then the list pane located on the right side shows the defined participants and connected participants, among which the recording link is indicated by the  icon.



**Figure 5-4** Recording Control

When a conference is going on, you can perform the following recording control operations through the recording buttons in the list pane or the right-click shortcut menu.

-  - Start recording
-  - Pause recording
-  - Stop recording



- The conference chairperson can also control recording in the PCM interface. For details, see *Recording a Conference*.
- For more information about the recording control operations of the RSS 2000, see *RSS 2000 User Guide*.



## Recording Properties

To view the status between the recording link and RMX1000, double-click the recording link, or right-click it and select **Properties** to view parameters.

- General - Displays the name, address, alias and other information.
- DTMF Code - A participant can use DTMF codes to send commands to the RSS server in real time, so as to easily complete recording operations.
- Connection Status - Displays in real time the RSS-RMX1000 connection status and disconnection cause.

# Meeting Rooms

A Meeting Room is a conference saved on the MCU in passive mode, without using any system resources. A Meeting Room is automatically activated when the first participant dials into it. Once activated, a Meeting Room functions as any ongoing conference. All Meeting Rooms are based on a Conference Profile. The RMX 1000 can support up to 5000 meeting rooms.

To set a meeting room, click **Meeting Room** in the *RMX Management* pane. The list pane shows the meeting rooms saved on the RMX 1000 and their summaries, such as the meeting room name, conference ID, conference duration, conference password, chairperson password, and conference profile. Here you can create, modify and delete meeting rooms.

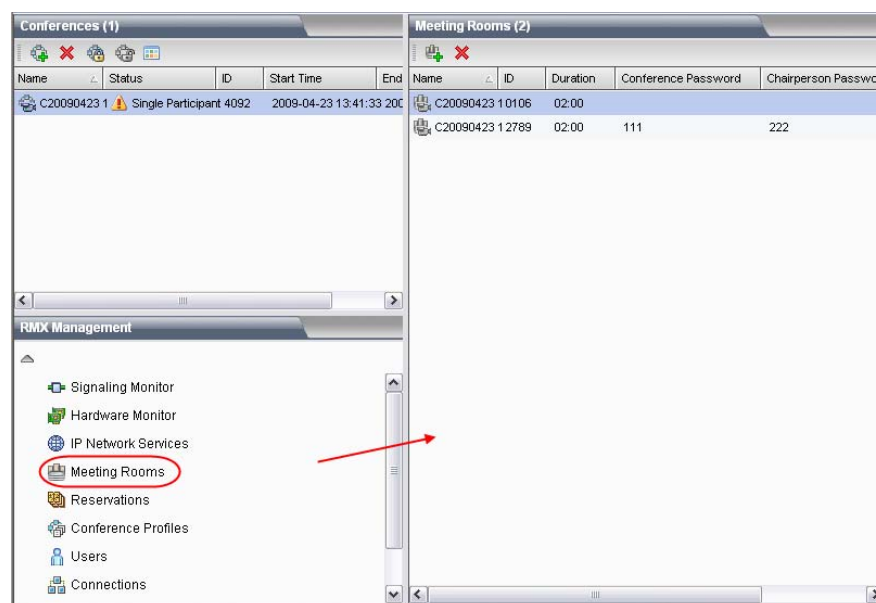



Figure 6-1 Meeting Rooms List

## Creating a Meeting Room

To create a meeting room, click the  button in the list pane or right-click in the blank area of the pane and then click **New Meeting Room**. The *New Meeting Room -> General* interface is displayed.

## General Settings

Meeting Room Name : C20090423 13:44

Profile : Default\_768\_CIF\_H264Content

Line Rate : 768Kbps

Minimum ports to be reserved : Automatic

Maximum ports to be used : Automatic

Duration : 2 : 0

Conference ID : 6115

Conference Password :

Chairperson Password :

Dial Out Manually

**Figure 6-2** New Meeting Room - General

The table below explains the detailed meanings of these parameters.

**Table 6-1** Parameter Description for New Meeting Room – General

Parameter	Description
<i>Meeting Room Name</i>	Set a unique name to identify the meeting room. When a meeting room is created, the system will automatically generate a unique name for it.
<i>Profile</i>	<p>Select the profile to be used for this conference from the drop-down list. The lower part of this option displays the major parameter values defined for the profile:</p> <ul style="list-style-type: none"> <li>▪ <b>Line Rate:</b> The maximum bandwidth to be used by each participant in the conference.</li> <li>▪ <b>Minimum ports to be reserved/Maximum ports to be used:</b> The minimum/maximum number of allowed conference participants. Automatic indicates that the number of video participants is determined according to the available resource of the RMX 1000.</li> </ul> <p>The conference profile defines the basic parameters of conference scheduling, such as the bandwidth, encryption, and video quality. For more information on conference profiles, see <i>Conference Profiles</i>. When a conference is created, the system selects the default profile of the device by default.</p>
<i>Duration</i>	Specify the conference duration in the range of 0-24 hours. The input format is H:M and the default value is 2:0, namely, 2 hours.
<i>Conference ID</i>	When a meeting room is created, the system automatically allocates a conference ID. You can also set a unique conference ID on the device. To directly dial into the conference, the participant must know its ID.
<i>Conference Password</i>	Enter the conference password. To connect to this conference, the participant must enter this password. If this parameter is empty, it means the conference has no password.

Parameter	Description
<i>Chairperson Password</i>	Enter the password that identifies the chairperson ID. The system will authorize more rights to the chairperson. If this parameter is empty, it means the conference has no chairperson.
<i>Dial Out Manually</i>	When enabled, the system will not automatically call the participants defined in the meeting room to join the conference unless the administrator dials out manually.

## Participant setup

You can add the participant information to the invited participant list for the meeting room. When the meeting room is activated, the system will automatically call the participants defined in the meeting room to join the conference. To set the invited participant list, click the **Participants** tab to enter the relevant interface, as shown below.

Type	Name	IP Address	H.323 ID/E.164
HDX	HDX	172.21.111.19	
QDX	QDX	172.21.111.221	
HDX2	HDX2	172.21.111.244	

Buttons: New, Edit, Remove, Add from Address Book

Lecture: Auto

Only participants in the above participant list can dial in.

Email Notification

**Figure 6-3** New Meeting Room - Participants

You can add participants to the list in the following two modes:

### To create a participant in the list:

- 1 Click the **New** button to create a participant.
- 2 The popup configuration interface is the same as that for adding a new participant to the address book. For explanation on the configuration parameters, see *Creating a Participant in the Address Book*.

### To add a participant from the address book to the list:

- 1 Click the Add from Address Book button.
- 2 In the popup address book, select the participant to be added, and then click the **OK** button. To select multiple participants at one time, click these participants one by one while pressing down the **Ctrl** key, or select adjacent ones while pressing down the **Shift** key.

To edit or delete a participant that is added to the list, select it, and then click the **Edit** or **Remove** button. A user can also click multiple participants to be deleted one by one while pressing down the **Ctrl** key, or select adjacent ones while pressing down the **Shift** key.

The table below shows the meanings of other optional parameters.

**Table 6-2** Parameter Description for New Meeting Room – Participants

Parameter	Description
<i>Lecture</i>	This option is available only when the video mode for the conference profile of meeting room is set to Lecture Mode. About settings of the video mode, see <i>Video Settings</i> . After adding participants to the list, you can select a participant from the drop-down list to act as the lecturer. By default, <b>Auto</b> is selected, meaning that the system uses voice activation to switch between the layouts, and the participant who speaks loudest will be selected as the lecturer. When the conference is running under the Lecture Mode, all participants' endpoints display the lecturer in full screen, and the lecturer's endpoint can time-switch to display other conference sites in rotation.
<i>Only participants in the above participant list can dial in</i>	When this option is selected, only the participants defined in the Participant List can dial into the conference.
<i>Email Notification</i>	If this option is selected, after you click <b>OK</b> , the system will automatically send an email message to notify each participant in the <i>Participant List</i> to join the conference. This option is enabled only when SMTP is configured in the <i>IP Network Services-&gt;Email</i> interfaces. For more information, see <i>Email</i> .

### Other Information

To configure other information for the meeting room, click the **Information** tab. Here you can configure conference notes, site details, accounting information, etc.

## Modifying a Meeting Room

To modify a meeting room, double-click the desired meeting room in the meeting room list; or right-click the meeting room, and then click **Meeting Room Properties**. For explanation on the configuration parameters, see *Creating a Meeting Room*.

## Deleting a Meeting Room

To delete a meeting room from the device, select the meeting room to be deleted in the meeting room list, and then click the **✘** button, or right-click the meeting room, and then click **Delete Meeting Room**.

# Reservations

Multiple types of conference reservations can be implemented using RMX 1000. You can reserve a conference for one time or convene routine conferences on a daily, weekly, or monthly basis as needed. The system reserves resources for conferences, so the conference can be automatically started at the preset time. The RMX 1000 can support up to 1000 reservations.



The reservation function is an optional function of RMX 1000 and will be available only when the user purchases the license. The device does not display the related options until the license for this function is activated. To obtain this function, contact your supplier.

To configure a reservation, click **Reservations** in the *RMX Management* pane. The list pane shows the related configuration interface. The reservation function provides two configuration views: Calendar view and List view.

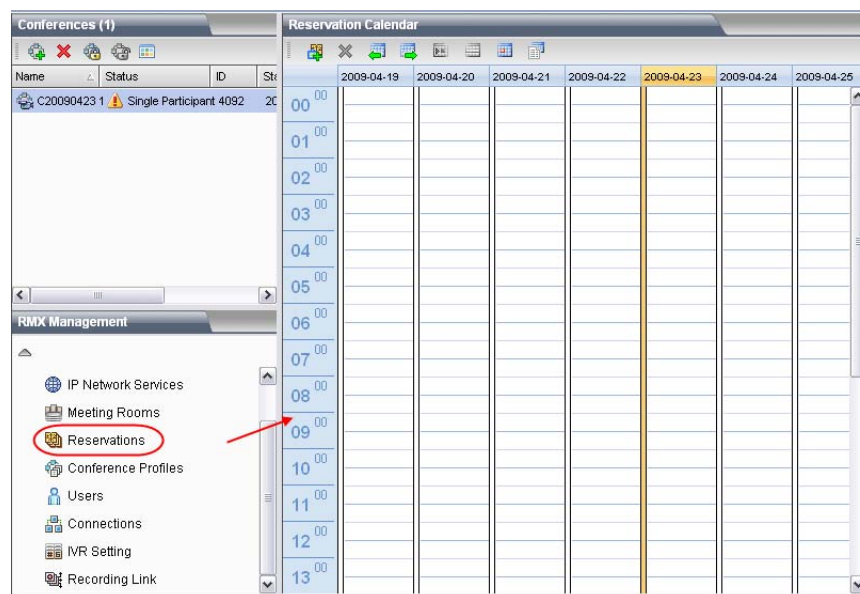



Figure 7-1 Reservation Setting Interface

## Reservations Views

### Calendar View



The Calendar view is displayed by default. It shows the distribution of reserved conferences on the RMX 1000 in a standard chronological calendar format. Under the calendar view, a user can switch to display the reservation information sorted by **Today**, **Day** or **Week**. A user can also directly reserve

a conference on a specific date to make conference scheduling clearer. When using the List view, click the  button to switch to the Calendar view.





### Switching Calendar Modes

Under the Calendar view, the system can display the calendar by day or by week so that users can easily view reservations over time. By default, the **Week** calendar is used to show the distribution of reservations.

#### To view the reservations per week:

- 1 At the **Today** or **Day** calendar mode, click the  button to show the reservations in a week.
- 2 When necessary, click  or  button to show the reservations of the previous week or next week.

#### To view the reservations per day:

- 1 In the **Week** calendar mode, select to show the calendar of today or another day:
  - Click  to show the conference reserved today;
  - Click  to display the conference on the selected date in the current calendar.
- 2 When necessary, click  or  button to show the reservations on the previous day or next day of the current date.

## List View

Under the reservation calendar view, click the  button to switch to the reservation list view.





Name	ID	Start at	Duration	Conference Password
C20090423 18442		2009-04-23 15:53	02:00	
C20090423 11831		2009-04-24 10:00	01:00	

Figure 7-2 Reservation – List View

The list view shows all the reservations on the current device in a list. A user can view all summaries of conferences, including the conference name, dial-in ID of the participant, conference start time and duration, conference password, chairperson password, and conference profile.

## Adding a Reservation

To reserve a conference:

- Under the calendar view, click the  button on the pane, or right-click at the blank area besides the selected calendar date and time, and then click **New Reservation**.
- Under the list view, click the  button on the reservation list pane, or right-click at the blank area, and then click **New Reservation**.  
On the *New Reservation* interface, you can set the basic conference information, participants, reservation time, and other related information. The procedures for setting the **General**, **Participants** and **Information** tabs are the same as those for setting a meeting room. For explanation on the configuration parameters, see *Creating a Meeting Room*.

To set a reservation, click the **Schedule** tab to enter the reservation interface. From the *Schedule Mode* drop-down menu, select the desired reservation mode to reserve a once, daily, weekly, or monthly conference.

### Reserving a One-Time Conference

A one-time reservation indicates that the reservation is only valid for one occurrence and will automatically be deleted after the conference ends. To reserve a one-time conference, select one of the following Schedule modes:

- **Permanent**: The reserved conference, after being started, will not be terminated until it is manually terminated or deleted by a chairperson or web UI user. This option can be selected if you cannot estimate the duration of the conference in advance.
- **Once**: The reserved conference, after being convened, will terminate at the specified time.

For either of the above modes, you need to set the *Start Time* of the reserved conference. In addition, for the *Once* mode, you need to set the duration of the reserved conference.

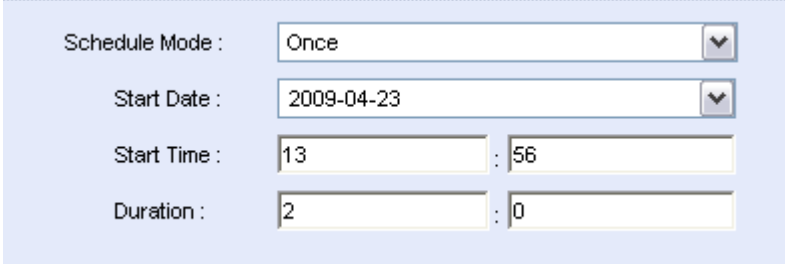

The screenshot shows a form titled "Reservation Setup - Once" with the following fields:

- Schedule Mode**: A dropdown menu set to "Once".
- Start Date**: A date picker set to "2009-04-23".
- Start Time**: Two input fields for hours and minutes, set to "13" and "56" respectively.
- Duration**: Two input fields for hours and minutes, set to "2" and "0" respectively.

**Figure 7-3** Reservation Setup - Once

**Table 7-1** Parameter Description for Reservation Setup – Once

Parameter	Description
<i>Start Date</i>	Set the start date of the conference.
<i>Start Time</i>	Set the start time of the conference in the format of H:M.



Parameter	Description
<i>Duration</i>	Set the duration of the conference in the format of H:M.

## Reserving a Daily Conference

To reserve a daily conference, set **Schedule Mode** to **Daily**.

Screenshot of the reservation setup form for a daily conference. The form includes the following fields:

- Schedule Mode : Daily (dropdown menu)
- Start Time : 13 : 56
- Duration : 2 : 0
- Start Date : 2009-04-23 (dropdown menu)
- End Date : 2009-04-24 (dropdown menu)

**Figure 7-4** Reservation Setup - Everyday

The conference will be convened at the specified time every day. In the specified period, this reservation is also deleted when the last conference is terminated. The table below explains the configuration parameters.

**Table 7-2** Parameter Description for Reservation Setup – Daily

Parameter	Description
<i>Start Time</i>	Set the start time of the conference in the format of H:M.
<i>Duration</i>	Set the duration of the conference in the format of H:M.
<i>Start Date</i>	Set the start date of the recurrence range of the reservation.
<i>End Date</i>	Set the end date of the recurrence range of the reservation.

## Reserving a Weekly Conference

To reserve a weekly conference, set **Schedule Mode** to **Weekly**.

Screenshot of the reservation setup form for a weekly conference. The form includes the following fields:

- Schedule Mode : Weekly (dropdown menu)
- Start Time : 13 : 56
- Duration : 2 : 0
- Start Date : 2009-04-23 (dropdown menu)
- End Date : 2009-04-24 (dropdown menu)
- Day selection:  Sun.  Mon.  Tue.  Wed.  Thurs.  Fri.  Sat.

**Figure 7-5** Reservation Setup - Weekly

The set conference will be convened at the specified time per week. In the specified period, this reservation is also deleted when the last conference is terminated. The table below explains the configuration parameters.

**Table 7-3** Parameter Description for Reservation Setup – Weekly

Parameter	Description
<i>Start Time</i>	Set the start time of the conference in the format of H:M.
<i>Duration</i>	Set the duration of the conference in the format of H:M.
<i>Start Date</i>	Set the start date of the recurrence range of the reservation.
<i>End Date</i>	Set the end date of the recurrence range of the reservation.
<i>Sun.~ Sat.</i>	Specify the weekday on which the reserved conference will be convened. Multiple weekdays can be selected. If you select the Mon. and Fri. check boxes, the conference will be automatically started at the specified time on every Monday and Friday.

## Reserving a Monthly Conference

To reserve a monthly conference, set **Schedule Mode** to **Monthly**.

Screenshot of the Reservation Setup - Monthly configuration interface. The interface shows a 'Schedule Mode' dropdown set to 'Monthly'. Below it are input fields for 'Start Time' (13:56), 'Duration' (2:00), 'Start Date' (2009-04-23), 'End Date' (2009-04-24), and 'Date' (1) with a '(1-31)' label.

**Figure 7-6** Reservation Setup - Monthly

The conference will be convened at the specified time per month. In the specified period, this reservation is also deleted when the last conference is terminated. The table below explains the configuration parameters.

**Table 7-4** Parameter Description for Reservation Setup – Monthly

Parameter	Description
<i>Start Time</i>	Set the start time of the conference in the format of H:M.
<i>Duration</i>	Set the duration of the conference in the format of H:M.
<i>Start Date</i>	Set the start date of the recurrence range of the reservation.
<i>End Date</i>	Set the end date of the recurrence range of the reservation.
<i>Date</i>	Specify the day of month on which the reserved conference will be convened. If you enter 1, the conference will be automatically convened at the specified time on the first day of every month.



At the specified time, the reserved conference will be convened automatically, the conference icon will become , and the properties of the conference can be viewed but cannot be modified. In addition, the conference list will show that the conference is ongoing.

## Modifying a Reservation

You can modify a reserved conference before it is convened.



### To modify the parameters of a reservation:

In the reservation calendar view or list view, double-click the reservation to be modified, or right-click this reservation and then click **Reservation Properties** to enter the reservation parameter setting interface. For explanation on the configuration parameters, see the previous section *Adding a Reservation*.

## Deleting a Reservation

You can delete a reserved conference before it is convened.

### Deleting a Reservation:

- In the reservation calendar view, select the reservation to be deleted from the calendar, and then click the  button, or right-click this reservation and then click **Delete Reservation**.
- In the list view, select the reservation to be deleted from the list, and then click the  button, or right-click this reservation and then click **Delete Reservation**.

For a one-time reservation, you need to confirm in the popup message box whether to delete it or not.

For a recurring reservation, in the reservation calendar view you need to confirm in the popup message box whether to delete this specific reservation or all occurrences of the event. In the list view, you need to confirm in the popup message box whether to delete one reservation or all occurrences of the event. If selecting **Delete one**, the page will turn to the reservation calendar view letting you to select which one to delete.

---

# Address Book

You can use the address book provided by the RMX 1000 to store participant information, such as the IP address and network communication protocol of the participant's endpoint. The address book enables you to conveniently and easily add participants to a conference.

The grouping function of the address book simplifies the creation of a conference. Different from the function of adding a single participant to the conference, the grouping function can be used to quickly add two or multiple participants to the conference at the same time.

If the RMX 1000 system is registered to a directory server, the address book contains the following two types of directories:

- **Local Directory:** Contains conference participants added by users through the Web management interface of RMX 1000. These entries are saved in the local RMX 1000 system, and can be edited, deleted, or exported by users.
- **Global Directory:** Contains information about Global Address Book entries stored in the external directory server the RMX 1000 system is integrated with. These address entries are stored in the directory server, and cannot be edited using RMX 1000.

Located in the rightmost part of the Web interface, the Address Book pane shows the participant information stored in the address book. A user can perform multiple operations through the toolbar buttons at the upper part of the pane (e.g. creating a participant, defining a participant group, deleting a participant or participant group, refreshing the address book, switching to display the address on the local or directory server, importing/exporting the address book, and searching a participant).

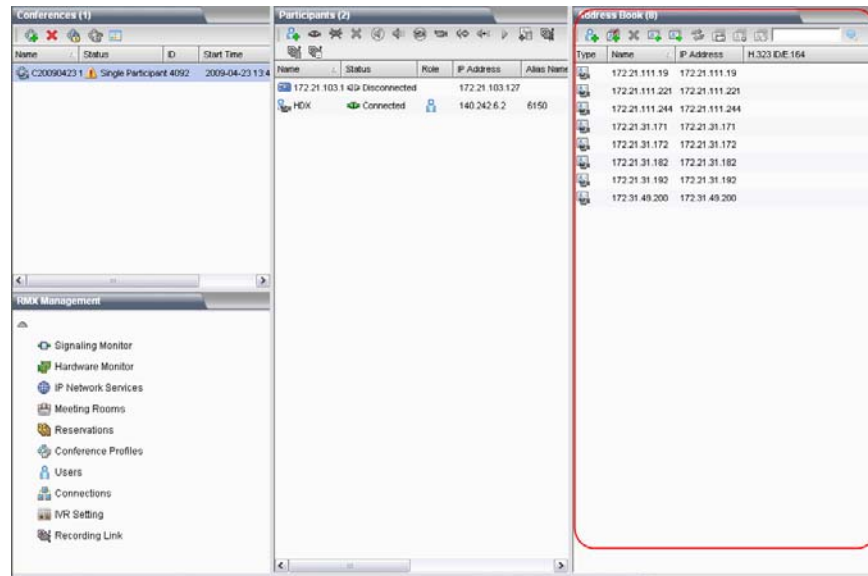



Figure 8-1 Address Book

## Adding a Participant to the Local Directory

You can add the information of a new participant to the local directory in the following two ways:

- Create a participant in the address book.
- Add a participant in the ongoing conference to the address book.

## Creating a Participant in the Address Book

Click the  button on the *Address Book* pane to add a new participant, and enter the *New Participants* - > *General* interface.

### General Settings

Name :

---

IP Address :

Type :

Alias :

Cascade :

Dialing Direction :

Extension :

Password :

Audio Only

Figure 8-2 New Participants - General

The table below explains the detailed meanings of these parameters.

**Table 8-1** Configuration Description of New Participants - General

Parameter	Description
<i>Name</i>	Enter a name to identify the participant.
<i>IP Address/Route Address</i>	<ul style="list-style-type: none"> <li>If the network type is set to H.323, enter the IP address of the participant's endpoint.</li> <li>If the network type is set to SIP, enter the route address of the participant's endpoint.</li> </ul> <p>This item is optional if an H.323 alias or SIP address is set in the <b>Alias/SIP Address</b> option below.</p>
<i>Type</i>	Select the network communication protocol used when the participant's endpoint dials in to the conference: H.323 or SIP. The option in the Alias/SIP Address drop-down list will change along with the network type selected here.
<i>Alias/SIP Address</i>	<ul style="list-style-type: none"> <li>If the network type is set to H.323, select the alias type of H.323 or E.164 in the right drop-down list, and then enter the related alias.</li> <li>If the network type is set to SIP, select the SIP address type in the right drop-down list, and then enter the related address.</li> </ul> <p>This item is optional if the IP address of the endpoint is set.</p>
<i>Cascade</i>	<p>If the device is a standard endpoint, select <b>No Cascade</b>.</p> <p>If the device will be a cascaded link to another MCU, set the master/slave relationship of the RMX 1000 relative to the participant: If the RMX 1000 is the master, select <b>Master</b>, otherwise select <b>Slave</b>. In the cascading mode, you need to set the following three items: <i>Dialing Direction</i>, <i>Extension</i>, and <i>Password</i>.</p>
<i>Dialing Direction</i>	<p>Select the dialing direction:</p> <ul style="list-style-type: none"> <li>Dial-in: The participant's device dials in the conference at the local RMX 1000. It is unnecessary to set the items Extension and Password if this option is selected.</li> <li>Dial-out: The local RMX 1000 dials out to the participant's device.</li> </ul> <p><b>Note:</b> <b>Dialing Direction</b> is available only when the <i>Slave</i> or <i>Master</i> is selected in <b>Cascade</b> option.</p>
<i>Extension</i>	Use this field in case the user would like to send an extension field to the remote end.
<i>Password</i>	Enter a DTMF code that will be sent upon connection to the remote end.
<i>Audio only</i>	If this option is selected, the participant will be defined as an audio participant, and the system does not support video input and output capabilities.



To add a participant who must be reached by dialing through a Polycom VBP (formerly known as V2IU), you need to enter the WAN IP address of the VBP in IP Address and the E.164 number of the VBP-registered endpoint in Extension.

**Example of cascading configuration**

There are two sets of cascaded RMX 1000 devices (RMX 1000\_1 and RMX 1000\_2). The information is as follows:

RMX 1000\_1

IP: 172.22.176.9

E.164 Prefix (Register to a GK): 80

ID of Master Conference (Dial out from): 1234

RMX 1000\_2

IP: 172.22.176.10

E.164 Prefix (Register to a GK): 86

ID of Master Conference (Dial into): 2222

Password of Master Conference (Dial into): 1111

To set the RMX 1000\_1 as the master device and dial to the conference at the RMX 1000\_2, perform the following configuration at the RMX 1000\_1:

The screenshot shows a configuration form for a device named 'Conf1'. The fields are as follows:

- Name: Conf1
- IP Address: (empty text box)
- Type: H.323 (dropdown menu)
- Alias: 86 (text box) and E.164: (dropdown menu)
- Cascade: Master (dropdown menu)
- Dialing Direction: Dial out (dropdown menu)
- Extension: 2222 (text box)
- Password: 1111 (text box)
- Audio Only: (checkbox, unchecked)

**Figure 8-3** Cascading Configuration – RMX 1000\_1

At the same time, configure as follows at the RMX 1000\_2:

Name : Conf2

IP Address :

Type : H.323

Alias : 80 E.164

Cascade : Slave

Dialing Direction : Dial in

Extension :

Password :

Audio Only

Figure 8-4 Cascading Configuration – RMX 1000\_2

### Advanced Setting

Usually, you only need to set the parameters on the **General** tab, and accept other default settings of the system. To set advanced parameters, click the **Advanced** tab.

Line Rate : Auto Kbps

Broadcast Volume : 1 5 10

Listen Volume : 1 5 10

Email :

Figure 8-5 New Participants - Advanced

The table below explains the configuration parameters.

Table 8-2 Configuration Description of New Participants – Advanced

Parameter	Description
<i>Line rate</i>	Specify the line rate of the participant's endpoint. <b>Auto</b> indicates using the line rate specified by the RMX 1000 system.
<i>Broadcast / Listen Volume</i>	Move the corresponding slider to adjust the volume transmitted/received by the participant. Each grid increases or decreases the sound by 3dB. The adjustable range is 1~10 (in the ascending order), while the default value is 5dB.
<i>E-Mail</i>	Set the Email address used by the participant to receive conference notices from the system. Up to 2 Email addresses can be set by separating them with a “;”. For example, enter address1@polycom.com; address2@polycom.com.



## Other Information

To add other information for the participant (company name, contact phone, etc.), click the **Information** tab and configure Info1~Info4, then click **OK**.

## Adding a Participant from an Ongoing Conference

You can also add a participant in an ongoing conference to the local directory. Operate as follows:

- 1 Click the desired conference in the *Conferences* list pane.
- 2 On the list pane, select the participant to be added, and then click the  button or right-click the participant, and then click **Add Participant to Address Book**.

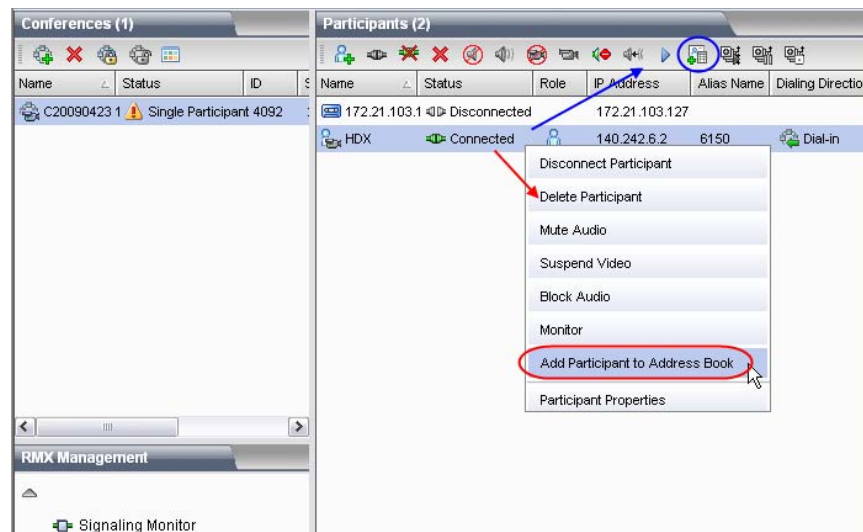



Figure 8-6 Adding a Participant from an Ongoing Conference

## Defining a Participant Group

A group is a collection of pre-defined participants. With the group function, you can conveniently add a group of participants to the conference. For example, to frequently convene conferences of the marketing department, you can create a group named *Marketing Team* that contains the endpoints of all the marketing department participants. You can invite all the members to the conference to be convened.

**To define a group:**

- 1 In the *Address Book* pane, click the  button or right-click in the blank area, and then click **New Group**.
- 2 The *New Group* page appears. Enter the name of the group in the *Group Name* field, e.g. **Marketing Team**.
- 3 Click **Add From Address Book**. In the participant list that appears, select the desired participant, and then click **OK**.
- 4 To select multiple participants at one time, click the desired participants one by one while pressing down the **Ctrl** key, or select adjacent ones while pressing down the **Shift** key. To delete an added participant from

the group, select it and click **Remove**. You can also delete multiple participants from the group.

- 5 Click **OK** on the *New Group* page to add the new group to the address book.

## Modifying a Participant/Group

To modify a participant or a group in the local directory, right-click the participant or group to be modified in the list, click **Participant Properties** or **Group Properties** to display and modify the detailed parameters.

## Deleting a Participant/Group

To delete a participant or a group from the local directory, click the participant or group to be deleted in the list, and then click the  button. Alternatively, right-click the participant or group, and then click **Delete Participant** or **Delete Group**. In the confirmation dialog box that appears, click **OK**.

You can also select the participant or group to be deleted, and then press the **Del** key to delete it.

## Importing and Exporting the Local Directory

### Exporting the Local Directory

A user can export entries from the local directory as a .csv file, for the purpose of backup or sharing between RMX 1000 devices. Directory lists from other devices (such as VSX or HDX endpoints) can not be backed up from or restored to the RMX 1000, even though the file format (.csv) may be the same.

**To export the local directory:**

- 1 Click the  button at the upper part of address book pane.
- 2 The dialog box for downloading file appears. Click **Save**.
- 3 Select or enter the path of saving this file at the local computer, and then click **Save**. The local address book will be saved at this specified path as a .csv file.



Groups defined in Address book can not be exported.

### Importing the Local Directory

**To import the local directory:**

- 1 Click the  button at the upper part of address book pane.
- 2 The interface for importing the address book appears. Click **Open**.

- 3 Select or enter the path where the address book file (.csv) to be uploaded is located, and then click **Open** to return to the interface for importing the address book.
- 4 Click **Upload**.



When uploading an address book file, conflicting participant addresses will not be overwritten.

## Directory Service

If the RMX 1000 system is successfully integrated with a directory server, the list of participants in the directory server will become the RMX 1000 address book.

### Configuring Directory Service

In the Web interface, click the *Setup->Directory Service* menu item at the upper left part to enter the *Directory Service* interface.

The RMX1000 supports the GAB and LDAP directory service modes. Select the mode supported by the directory server that is provided by your local network. **None** is selected by default, indicating that directory service is not used. Depending on different directory service modes selected from **Type** by users, the system requires configuring different parameters.

#### GAB Server

To register RMX 1000 to the GAB server, select **GAB** from **Type**.

**Figure 8-7** Directory Service - GAB

Configure parameters in accordance with the table below:

**Table 8-3** GAB Configuration Parameters

Parameter	Description
Server	Set the IP address of GAB server.
Password	Enter the password (if available) of global directory.

## LDAP Server



To register RMX 1000 to the LDAP server, select **LDAP** from **Type**.

**Figure 8-8** Directory Service - LDAP





Configure parameters in accordance with the table below:

**Table 8-4** LDAP Configuration Parameters





Parameter	Description
<i>Server</i>	IP address of the LDAP directory server
<i>Server Port</i>	LDAP server port No.
<i>Base Distinguished Name (DN)</i>	LDAP Base DN
<i>Authentication Type</i>	LDAP authentication type. Depending on different authentication types selected by users, the system requires configuring different options.
<i>Use Secure Socket Layer (SSL)</i>	Specify whether to use SSL secure transmission or not.
<i>Domain Name</i>	LDAP server domain name
<i>Bind Distinguished Name (DN)</i>	LDAP bind DN
<i>User Name</i>	User name of the LDAP directory
<i>Password</i>	Enter the password (if available) of LDAP directory.

After the configuration is finished,  will be displayed if the directory service is successfully registered, or else  is displayed.

## Viewing the Global Directory









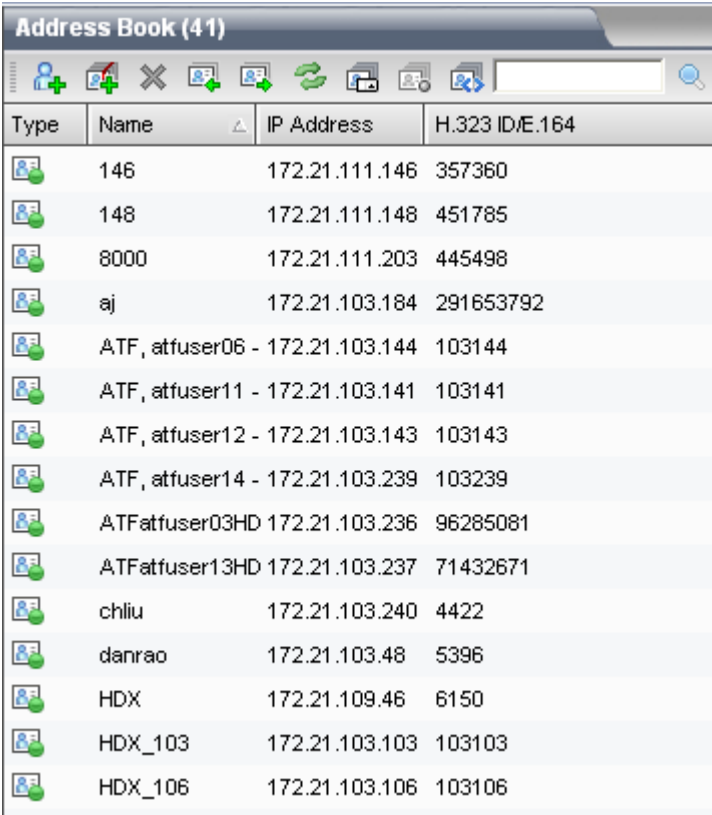





After the directory server is successfully registered, the global directory buttons (   ) on the address book pane will be activated. The table below defines the functions of these buttons:

**Table 8-5** Function Definitions of Global Directory Buttons

Button	Function
	The global directory will be automatically refreshed at regular intervals to synchronize the address change on the directory server. You can click this button to manually refresh the global directory.
	This button is available when the global directory list is displayed. Click this button to switch to the local directory list.
	This button is available when the local directory list is displayed. Click this button to switch to the global directory list.
	Display both the local and global directory lists.

Click the  button on the address book pane to display the global directory list, as shown below. The list shows the information of other endpoint sites registered to the directory server. The green icon indicates that this endpoint can be used to dial in to the conference, and the grey icon indicates that this endpoint is offline.



Type	Name	IP Address	H.323 ID/E.164
	146	172.21.111.146	357360
	148	172.21.111.148	451785
	8000	172.21.111.203	445498
	aj	172.21.103.184	291653792
	ATF, atfuser06 -	172.21.103.144	103144
	ATF, atfuser11 -	172.21.103.141	103141
	ATF, atfuser12 -	172.21.103.143	103143
	ATF, atfuser14 -	172.21.103.239	103239
	ATF atfuser03HD	172.21.103.236	96285081
	ATF atfuser13HD	172.21.103.237	71432671
	chliu	172.21.103.240	4422
	danrao	172.21.103.48	5396
	HDX	172.21.109.46	6150
	HDX_103	172.21.103.103	103103
	HDX_106	172.21.103.106	103106

**Figure 8-9** Global Directory List

## Searching Directory Entries

A user can use the *Search* function of address book to quickly find the specified participant or participant group when the address book stores the information of numerous participants.

To search for a participant or participant group, enter the name of participant or participant group to be queried in the search box  on the address book pane, and click the  button. You can enter the full name of the participant or group if that information is known, or the first part of the name if the entire name is not known.



To return to the address book after searching, clear the entered keyword, and click to re-query.



# Conference/Participant Monitoring

Through the real-time conference-monitoring platform of the system, you can easily monitor ongoing conferences, track participants and conference progress, and perform control operations as needed. With the RMX 1000, you can implement two types of monitoring operations:







- Conference monitoring - On the main window, view the ongoing conferences and information about the specified conference and specified video, and change the conference control, management and other parameters as needed.
- Participant monitoring - View the status and detailed parameters of participants, change the screen layout of the endpoint, and set a message overlay to be viewed by the site.

## Conference Monitoring

### Viewing Conferences List Pane

The *Conferences* list pane always shows information about ongoing conferences. The table below explains conference information.

**Table 9-1** Conference Information

Parameter	Conference Information
<i>Name</i>	The interface displays the conference name.
<i>Status</i>	<p>The interface displays the status of the ongoing conference. No indication will be displayed if the connection of participants is normal. Corresponding indicators appear with a warning icon at the occurrence of the following statuses:</p> <ul style="list-style-type: none"> <li>▪  Audio – Problems with the participant's audio</li> <li>▪  Empty – No participant is connected.</li> <li>▪  Faulty Connection – Participants are connected, but the connection is problematic.</li> <li>▪  Not Full – Not all the defined participants are connected.</li> <li>▪  Partially Connected – The connection process is not yet complete, and the video channel has not been connected.</li> <li>▪  Single Participant – Only one participant is connected.</li> <li>▪  Video – Problems with the participant's video</li> </ul>



Parameter	Conference Information
<i>ID</i>	The Conference ID assigned to the conference
<i>Start Time</i>	Conference start time
<i>End Time</i>	The time the conference is expected to end

## Viewing Conference Parameters

In addition to the status information shown in the conference list, you can view detailed parameters of an ongoing conference. Double-click the desired conference or right-click the conference, then click **Conference Properties**. The *Conference Parameters* interface shows the configuration of the conference. Here you can change the end time, password and chairperson password of the conference, adjust the conference layout, set the conference message overlay and conference name, etc. The unavailable options cannot be modified.

## Conference Control

### Previewing the Conference

The snapshot of each conference site is available to users. Select the conference to be previewed on the conference list pane, and click the  button to show the snapshot of each conference site.

### Changing End Time

When a conference is created, its duration is also set. The default duration is 2 hours.

When a conference is occurring, you can extend or shorten its duration by changing its end time. You can also manually delete an ongoing conference.

#### To change the conference duration:

- 1 Double-click the desired conference in the *Conferences* list pane.
- 2 On the **General** tab of the *Conference Parameter* interface, change **End Time**, and then click **OK**.



The conference duration cannot exceed 24 hours.



**To manually terminate a conference:**

- 1 In the conference list, click the conference to be deleted, and then click the  button, or right-click the conference, and then click **Delete Conference**.
- 2 In the confirmation dialog box that appears, click **OK**.

**Locking/unlocking a Conference**

After an ongoing conference is locked, any endpoint that is not already part of the participant list cannot dial into the conference actively. After the conference is unlocked, any endpoint can dial into the conference.

To lock or unlock a conference, select one of the following two modes:

- Select the conference in the conference list, and then click the locking button /unlocking button  on the pane, or right-click the conference, and then select **Conference Lock/Conference Unlock** from the shortcut menu.
- Double-click this conference to enter the conference parameter interface. On the *Advanced* tab interface, select or deselect the **Conference Lock** check box.

**Setting the Talk Hold Time**

In the voice activation mode, if the talk of a participant reaches the set time, this participant will be automatically set to the speaker. In different video modes, different display rules apply to the speaker's endpoint:

- In the Lecture Mode, if a user sets to automatically select a lecturer through voice activation, the speaker will become a lecturer and be displayed in full screens at other participants' endpoints, and the speaker's endpoint will display the screens of other sites.
- In the same video mode, the image outline at the speaker's endpoint will be highlighted when multi-screen windows are at the same size. While, if the multi-screen windows are at different sizes, the image of the speaker's endpoint will be switched to the largest window.

To set the talk hold time, double-click this conference to enter the conference parameter interface. Enter the time in the **Talk Hold Time** text box on the *General* tab interface, in the range of 2-60 seconds.

**Changing Conference and Chairperson Passwords**

- 1 In the *Conferences* list pane, double-click the desired conference.
- 2 On the *General* tab, set Conference Password and Chairperson Password, and then click **OK**.

**Changing Conference layout**

You can change the video mode and screen layout of an ongoing conference. The initial video mode and screen layout of the conference is in accordance

with the conference profile.



### To select a conference video mode:

- 1 In the *Conferences* list pane, double-click the desired conference.
- 2 Click the **Video Settings** tab on the conference parameter interface.
- 3 Select the required mode in **Video Mode**.
  - Lecture Mode: All the participants' endpoints will display the lecturer in full screens, and the lecturer's endpoint will display other participants according to the layout set here. After this option is selected, the **Lecture** option is activated. Specify a lecturer in the drop-down list. **Auto** indicates that the voice activation feature will be used to select the participant whose talk time reaches the defined duration as the lecturer. For settings of the talk hold time, see *Setting the Talk Hold Time*.
  - Same Layout: All the participants' endpoints in the conference will display the same image according to the layout set here. This setting will allow sites to see their own loopback images.
  - Conference Layout: All the participants' endpoints in the conference can be freely defined to display various multi-screen layouts.

### Set the layout

Based on the selected video mode, a user can set to automatically select the screen layout according to the number of added participants or specify a fixed screen layout.

### To set automatic screen layout:

- 1 Click **Auto** at the left part of the layout setting area to display the automatic layout pane.
- 2 Select the maximum screen layout so that the conference site displays at most the number of multi-screen windows set here. In this mode:
  - When the number of participants is smaller than or equal to the set number of multi-screens, the system displays multi-screen image according to the actual number of participants and in line with the default rule. For the default rule, see *Table 4-9 Default Rule of Automatic Layout*.
  - When the number of participants is greater than the set number of multi-screens, the system uses the voice activation feature, and switches to display the first participants who speak loudest with the largest multi-screen layout selected here. If the number of participants is greater than 4 and the maximum selection is , the system will display the first four participants who speak loudest using the  layout.

### To set fixed screen layout:

Click the desired layout number, and then select the desired layout. The interface shows the thumbnail of the layout. For the video display in each video window, you can select one of the following modes from the drop-down list:

- **Auto:** This option is selected by default. Each multi-screen window will automatically select to display a conference site based on the information about connected participants.
- **Auto Scan:** After this option is selected, if the set multi-screen number is smaller than the number of connected participants, the window will display images of the rest participants in turn, and the time interval for switching between the conference sites is the value of **Auto Scan Interval**.
- Directly select an endpoint conference site to be displayed at the window.



In the Same Layout mode, participants will view the video of their conference sites.

### Setting the Conference Message Overlay

When a message needs to be sent to all participants in a conference, you can set the message overlay to be displayed on all participants' endpoints screen.

To set a message overlay:

- 1 In the *Conferences* list pane, double-click the desired conference.
- 2 On the conference parameter interface, click the **Message Overlay** tab, and set the required parameters.

**Table 9-2** Setting Message Overlay

Parameter	Description
<i>Enable</i>	Select this option to enable message overlay. Then you can set other parameters.
<i>Message Text</i>	Enter the content to be displayed.
<i>Font Size</i>	Set the font size of the message overlay.
<i>Color</i>	Set the color-matching scheme for the message overlay font and background.
<i>Display Repetitions</i>	Move the slider to set the display times of the message overlay.
<i>Display Speed</i>	Move the slider to set the display speed of the message overlay.
<i>Vertical Border</i>	Move the slider to set the vertical boarder of the message overlay.
<i>Contrast</i>	Move the slider to set the contrast of the message overlay.

### Setting the Site Name

The site name is also the endpoint name, which marks each site on the viewed screen. The site name displayed at each participant's endpoint comes from the system name set for the endpoint.

To set the site name:

- 1 In the *Conferences* list pane, double-click the desired conference.
- 2 On the conference parameter interface, click **Site Name** to enter the site-setting interface. Select the **Always show site name** check box, and set the related parameters. You can set **Font Size** and **Display Position**.



In the video switching conference mode, you cannot set the conference Message Overlay or site name.

## Participant Monitoring

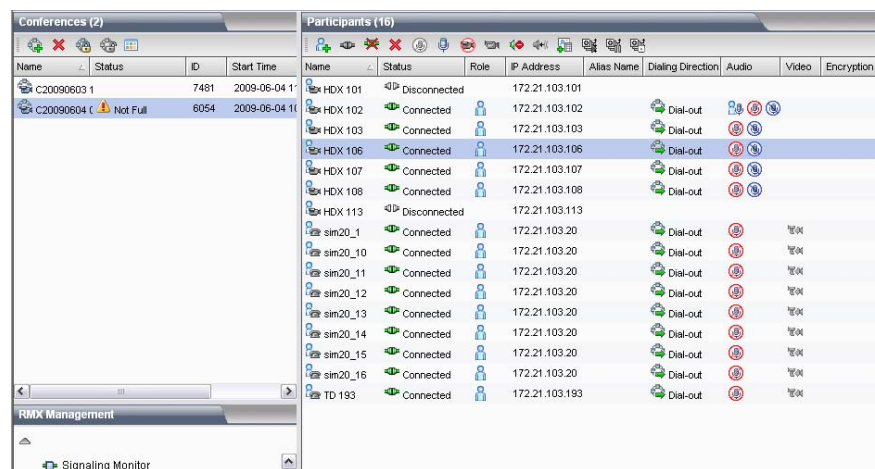

Figure 9-2 Participant Monitoring Pane



















When a conference is ongoing, you can view detailed status and properties of each participant's endpoint and perform related setup and operations through the Participants list pane.



### Viewing Participant List

Click an ongoing conference in the conference list. The list pane then shows all the participants connected to the conference and those not connected to the conference but added to the participant list.

Table 9-3 Description of Participant List Parameters

Parameter	Description
Name	Displays the name and type of the participant: <ul style="list-style-type: none"> <li>▪  <b>Audio Participant</b> – Connected to an audio user</li> <li>▪  <b>Video Participant</b> – Connected to a video user</li> <li>▪  – Recording Link</li> </ul>

Parameter	Description
Status	<p>Displays the connection status of the participant:</p> <ul style="list-style-type: none"> <li> <b>Connected</b> – The participant is successfully connected to the conference.</li> <li> <b>Disconnected</b> – The participant is disconnected from the conference. This status applies only to defined participants.</li> <li> <b>Partially Connected</b> – The connection process is not yet complete, and the video channel has not been connected.</li> <li> <b>Connecting</b> – The participant is being connected.</li> <li> <b>Redialing</b> – The participant is not be connected successfully and now being redialed.</li> <li> <b>Faulty Connection</b> – The participant is connected, but problems occurred in the connection, such as synchronization loss.</li> </ul>
Role	<p>Displays the participants role or function in the conference:</p> <ul style="list-style-type: none"> <li> – Regular participant</li> <li> – The participant will be defined as the conference chairperson and have more privileges to manage conferences through the endpoint interface.</li> <li> – The participant is defined as the lecturer.</li> <li> – The participant is defined as both the lecturer and the chairperson.</li> </ul>
IP Address	The participant's IP address
Alias	The participant's Alias Name
Dialing Direction	<ul style="list-style-type: none"> <li> <b>Dial-in</b> – The participant dialed the conference.</li> <li> <b>Dial-out</b> – The MCU dialed the participant.</li> </ul>
Audio	<p>Displays the status of the participant's audio channel: If the participant's audio connection is normal and the channel is neither muted nor blocked, no indication is displayed.</p> <ul style="list-style-type: none"> <li> <b>Muted</b> - The selected endpoint is muted so that its audio cannot be sent to other conference sites.</li> <li> <b>Blocked</b> – The selected endpoint is blocked so that it cannot hear the audio of other conference sites.</li> <li> – The selected endpoint is muted and blocked at the same time.</li> <li> <b>Lecturer</b> - The selected endpoint is the lecturer or the primary speaker.</li> </ul>
Video	<p>Displays the status of the participant's video channel: If the participant's video connection is normal and the channel is neither suspended nor secondary, no indication is displayed.</p> <ul style="list-style-type: none"> <li> <b>Suspended</b> – Video transmission from the endpoint to the conference is suspended.</li> <li> <b>Secondary</b> – Participant is connected only through the audio channel due to problems with the video channel.</li> </ul>
Encryption	 Indicates that the endpoint is using encryption for its connection to the conference

Parameter	Description
<i>FECC Token</i>	 The participant has the Far End Camera Control (FECC) Token and is capable of conducting FECC. FECC Token can only be allocated to one participant at one time. If no participant uses the FECC function, this icon is not displayed.
<i>Content Token</i>	 The participant is sending dual streams.

## Viewing Participant Properties

To view detailed parameters of a participant, double-click the desired participant in the participant list, or right-click the participant, and then click **Participant Properties**.

The parameters displayed on the *General*, *Advanced* and *Information* tab pages are the same as those for adding a new participant. For explanation on configuration parameters, see *Adding a Participant to the Local Directory*.

The **Connection Status** tab shows the status and detailed information of the participants, including time of connecting / disconnecting, cause of disconnecting, network transfer rate, packet loss ratio, audio, video, etc.









In the *Multimedia Settings* tab page, you can set whether to mute, block, or suspend a participant or not.













## Participant Control

You can control and modify the participant's connection status of an ongoing conference through the buttons in the *Participant* list pane, the *Participant* right-click shortcut menu, and the *Participant Properties* interface.

The table below explains all the buttons in the *Participant* list pane.

**Table 9-4** Buttons in the Participant List Pane

Button	Name	Description
	<i>New Participant</i>	Define a new participant. For more information about the <i>New Participant</i> dialog box, see <i>Creating a Participant in the Address Book</i> .
	<i>Connect Participant</i>	Connect a disconnected defined dial-out participant to the conference.
	<i>Disconnect Participant</i>	Disconnect the participant from the conference.
	<i>Delete Participant</i>	Delete the selected participants from the conference.
	<i>Mute Audio</i>	Mute the audio transmission from the participant to the conference. The Audio Muted indicator appears in the <i>Participants List</i> and the Unmute Audio button becomes active (  ).
	<i>Unmute Audio</i>	Participant's audio transmission to the conference resumes. The Mute Audio button becomes active (  ).

Button	Name	Description
	<i>Suspend Video</i>	Suspend the video transmission from the participant to the conference. The suppressed participant's video is not transmitted to the conference but the participant still receives conference video. The <i>Suspend Video</i> indicator appears in the participant list and the <b>Resume Video</b> button becomes active (  ).
	<i>Resume Video</i>	Participant's video transmission to the conference resumes. The <b>Suspend Video</b> button becomes active (  ).
	<i>Block Audio</i>	To block the audio transmission from the conference to the participant. When blocked, the participant can still be heard by the conference. The <i>Audio Blocked</i> indicator appears in the <i>Participants List</i> and the Unblock Audio button becomes active (  ).
	<i>Unblock Audio</i>	Conference audio transmission to the participant resumes. The <b>Block Audio</b> button becomes active (  ).
	<i>Add Participant to Address Book</i>	Open the address book, and then select the desired participants. For more information about the address book, see <i>Address Book</i> .
	<i>Start Recording</i>	Start conference recording.
	<i>Pause Recording</i>	Stop conference recording temporarily.
	<i>Stop Recording</i>	Terminate conference recording.

In the participant list, right-click any connected participant to display the shortcut menu. Through this shortcut menu, you can conduct common participant control operations. If you right click an unconnected but defined participant, the shortcut menu only provides some of the above operations.

## Control Operations

### Setting Conference Layout for Participant's Endpoint

If the layout mode is set to **Conference Layout** on the conference parameter interface, you can customize the layout of each participant's endpoint at the Web interface.

#### To define the screen layout of each participant:

- 1 In the participant list, double-click the participant to be defined, or right-click this participant, and then click **Participant Properties** to enter the participant parameter interface.
- 2 Click the **Video Settings** tab, and then select **Personal** from *Layout Type*.
- 3 Set layout for the endpoint. The procedure for setting layout here for the endpoint is similar to that for setting conference layout. For more information, see *Changing Conference layout*.





- The layout set at the *Participant Properties* page takes effect only for this participant's endpoint.
- The layout set at the *Participant Properties* page is prior to that set on the *Conference Properties* page. In other words, the layout set here is adopted for the participant's endpoint, not being affected by the setting of conference layout.

## Move a Participant between Conferences

You can drag a participant from a running conference directly into another conference through the *Web management* interface. Then, based on video parameters defined for the target conference, the system will automatically adjust the video capability when the participant is connected.

**To move a participant:**

- 1 Click the name of the participant to be moved, and drag it as pressing the left mouse key. You will find the cursor changes to .
- 2 Drag the participant onto the conference to join on the conference list pane, and release the left mouse key when the conference is highlighted.

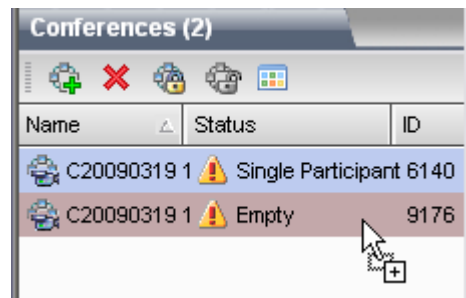

**Figure 9-3** Moving a Participant



You cannot move a participant between an encrypted conference and a non-encrypted conference.

## Setting Message Overlay for an Endpoint

You can choose to display message overlay to an individual participant and not the entire conference.

**To set a message overlay for a participant's endpoint:**

- 1 In the participant list, double-click the participant to be defined, or right-click this participant, and then click **Participant Properties**.
- 2 On the *Participant Properties* interface, click the **Message Overlay** tab. The steps for setting up message overlay here are similar to setting up message overlay on the conference parameter interface. For more information, see *Setting the Conference Message Overlay*.



- For an HD conference, the system does not provide the message overlay function.
- The message overlay set at the *Participant Properties* page supersedes any message overlay set on the *Conference Properties* page. When the two settings conflict with each other, the message overlay on the participant's endpoint screen is displayed as follows: The participant's message overlay, even if set later than the conference overlay, immediately replaces the conference level message overlay. The conference level overlay will not be displayed until the participant level overlay is finished displaying.



---

# Users and Connections

Users who are defined in the Web interface can log into the Web management interface to complete authorized operations. The RMX supports three user connection levels:

- Chairperson
- Operator
- Administrator

A Chairperson can only manage ongoing conferences and participants. The Chairperson does not have access to the RMX configurations and utilities.

An Operator can perform all the RMX tasks a Chairperson does. In addition, Operators can also view the RMX configurations.

An Administrator can perform all the tasks of Chairpersons and Operator users. In addition, Administrators can perform all configuration and maintenance tasks.

Administrator and Operator users can verify which users are defined in the system. Neither of them can view the user passwords, but an Administrator can change a password.

The *Users Pane* lists the currently defined users in the system and their authorization levels. The authorization level dictates a user's capabilities within the system. The pane also enables the administrators to add and delete users.

The RMX 1000 is shipped with a default Administrator user called **POLYCOM**, whose password is **POLYCOM**. However, once you have defined other Administrator users, it is recommended to modify the default password.

## User List

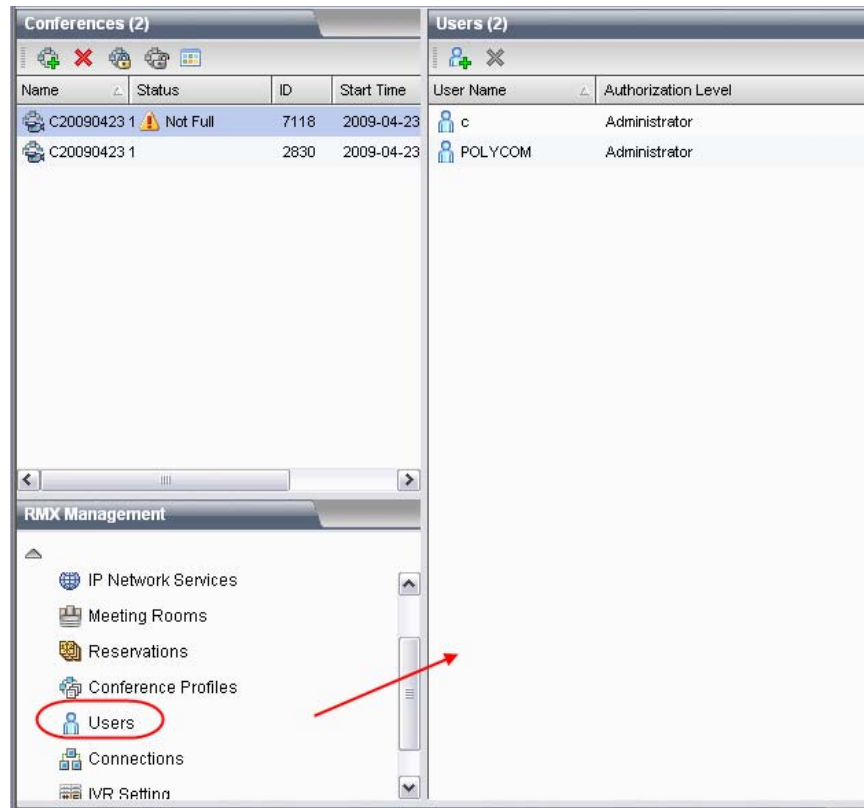

Figure 10-1 User List Pane

To view the defined users for the current system, click **Users** in the *RMX Management* pane. The defined user list appears in the list pane located on the right side.

The user name displayed in the list is the login name for the user to connect to the device's Web pages, with its permission level indicating the user's authorization level.

Click a column header to automatically sort users by name or authorization levels, which makes it easy for the administrator to manage users.

## Defining New User

Only users with Administrator privileges are allowed to define new users.

To create a new user, click the  button in the User List pane or right-click in the blank area of the list and then click **New User**. The *New User* interface appears.

**Figure 10-2** New User Settings Page

**Table 10-1** Description for New User Settings

Parameter	Description
<i>User Name</i>	Enter the user name for logging in to the system's Web page
<i>Password</i>	Enter the password for logging in to the system's Web page
<i>Authorization Level</i>	Set the authorization level of the user to Administrator, Operator, or Chairperson.
<i>Receive the Email When System Alerts</i>	If enabled, the user will receive an Email when a system alert is generated. It is only available for Administrator-level users.
<i>Email Address</i>	Enter the Email addresses for recipients here if <b>Receive the Email When System Alerts</b> is enabled.

## Deleting User

Only users with Administrator privileges are allowed to delete other users.

To delete a user, click this user in the user list and then click the  button or right-click this user and select **Delete User**.

## Modifying User Password

Only users with **Administrator** privileges are allowed to modify passwords of other defined users.

To modify the password of a user, right-click the user you want to modify in the user list and select **Change User Password**. The page for password modification appears. Enter the old password, new password, and confirmation password to complete the modification.

## Viewing User Connection

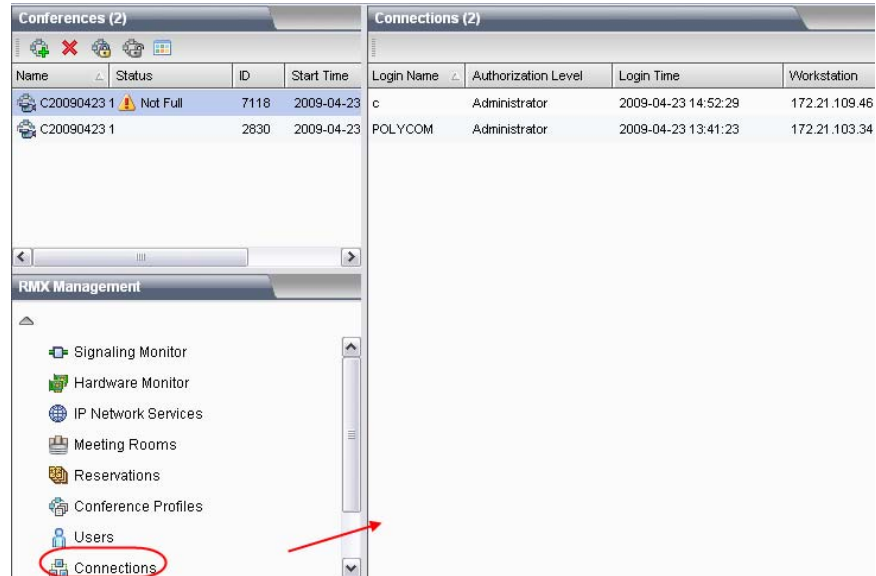

**Figure 10-3** User Connection List

The Web management page for the device can list all connections (all users, servers, or others logged into the devices) to the Web interface.

To view connected users, click **Connections** in the *RMX Management* pane. The list of connected users including the following information is displayed in the list pane on the right side.

- User login name
- Authorization level of the user (conference chairperson, operator, or administrator)
- User login time
- User computer name or ID

# IP Service Settings

Click **IP Network Services** in the *RMX Management* pane to display the related IP information-setting page on the list pane. The corresponding IP information of the device will be displayed on the list pane, including the IP addresses and Gateway addresses for port LAN1 and LAN2, and the addresses of the NAT server and DHCP server.

Name	Status	ID	Start Time
C20090423 1	Not Full	7118	2009-04-23
C20090423 1		2830	2009-04-23

Network Interface	IP Address	Gateway	NAT	DHCP
LAN1	172.21.103.224	172.21.103.254	NO	Disable
LAN2	123.124.235.154	123.124.235.129	NO	Disable

**Figure 11-1** IP Network Services

Right-click a LAN port and click **Properties** to display the *IP Network Services* interface. You can view and modify the detailed parameter information here.



## LAN Setting

Configure the LAN information in the *IP Network Services* interface.

**Figure 11-2** *IP Network Services - LAN Port Setting*

**Table 11-1** *LAN Port Setting Parameters*

Parameter	Description
<i>Use LAN1 (2)</i>	Enables/disables the network port.
<i>DHCP</i>	If the user network is configured with a DHCP (Dynamic Host Configuration Protocol) server, select this option to automatically obtain the IP address. Deselect this option to use a static IP address, in which case you need to configure the next three options.
<i>IP Address</i>	Set the IP address for this network port
<i>Subnet Mask</i>	Set the Subnet Mask for this network port.
<i>Gateway</i>	Set the gateway address of this port. If Set as Default is selected and no matched static routes are found, the device packets will be transmitted via this gateway by default. A default route will be displayed in the list of <i>IP Network Services-&gt; Routers</i> page. For more information, see <i>Routers</i> .
<i>NAT</i>	The <i>NAT</i> (Network Address Translation) function enables you to translate a private network IP address into a public network IP network before transmission. To enable NAT, select this check box and then set the public network IP address to be displayed to the outside in the <i>NAT IP</i> field.

Parameter	Description
<i>Obtain DNS Server Address Automatically</i>	Used in combination with the DHCP option. When the DHCP check box is selected, this option allows you to obtain the DNS server address automatically from a DHCP server in the network.
<i>Preferred/Alternate DNS Server</i>	If you did not select the option for automatic DNS address discovery, you must enter the preferred/alternate DNS server addresses here for the device to resolve domain names.
<i>LAN Speed</i>	Set the speed/duplex modes for LAN ports. Supported speed/duplex modes include the 10/100M, Full Duplex or Half Duplex mode and the 1000M Network mode. You can also select <b>Auto</b> to use Auto-Negotiation with the switch port. <b>Note:</b> Contact the network administrator before setting <b>LAN Speed</b> , to ensure that the link rate of switch is matched with the MCU port.
<i>MTU Size</i>	Specifies the Maximum Transmission Unit (MTU) size used in IP calls and Web communications. If the video becomes blocky or network errors occur, packets may be too large; decrease the MTU. If the network is burdened with unnecessary overhead, packets may be too small; increase the MTU.

## Routers

In the *IP Network Services* interface, click **Routers** to configure the routing information.

Router IP Address	Remote IP Address	Subnet Mask
123.124.235.129	0.0.0.0	0.0.0.0
172.21.103.254	172.0.0.0	255.0.0.0
172.21.103.254	10.0.0.0	255.0.0.0

**Figure 11-3** IP Network Services - Routers

The *Routers* page displays the information for the configured routes in the system. The RMX 1000 packets will be transmitted via these static routes. You can modify or delete an existing route by selecting the route, or just click the **New** button to create a new route. The table below shows the descriptions for route parameters.

**Table 11-2** *Routers Setting*

Parameter	Description
<i>Router IP Address</i>	Set the IP address for the sending router of packet transmission
<i>Remote IP Address</i>	Set the target network address for packet transmission
<i>Subnet Mask</i>	Set the subnet mask for the target network



You cannot modify the default route on this page. To set the default route, select the *IP Network Services -> Properties* page, and then select the **Set as Default** check box next to the configured gateway. For more information, see *LAN Setting*.

## Gatekeeper

In the *IP Network Services* interface, click **Gatekeeper** to configure the gatekeeper information.

If a gatekeeper device is configured on your network, you have the option to register RMX 1000 with the gatekeeper and configure the related parameters.

IP Network Type :

---

Register to Gatekeeper

Primary Gatekeeper Disabled

Gatekeeper IP Address :

Gatekeeper Port :

Alternate Gatekeeper Disabled

Gatekeeper IP Address :

Gatekeeper Port :

System Prefix/E.164 :

System H.323 Alias :

**Figure 11-4** *IP Network Services - Gatekeeper*

The table below explains the specific meanings for the configuration options.

**Table 11-3** Gatekeeper Setting

Parameter	Description
<i>IP Network Type</i>	<p>Set the IP network type for the RMX 1000 system to make a call. You need to set it based on the call type used for the participant's endpoint. It can be set to:</p> <ul style="list-style-type: none"> <li>▪ <b>H.323</b>: Only H.323 calls are supported.</li> <li>▪ <b>SIP</b>: Only SIP calls are supported.</li> <li>▪ <b>H.323 &amp; SIP</b>: H.323 calls and SIP calls are supported at the same time.</li> </ul> <p>Settings of the gatekeeper related parameters are available only when the H.323-supporting network type is selected.</p>
<i>Register to Gatekeeper</i>	Set whether or not to register with the gatekeeper. You must check this option to set the parameters that follow.
<i>Primary (Alternate) Gatekeeper</i>	Indicates whether or not the device is registered with the primary (or alternate) gatekeeper.
<i>Gatekeeper IP Address</i>	Set the IP address for the primary (or alternate) gatekeeper.
<i>Gatekeeper Port</i>	The port number for the primary (or alternate) gatekeeper.
<i>System Prefix/E164.</i>	Set the E.164 number for the system.
<i>System H.323 Alias</i>	Set the H.323 alias for the system.

## SIP Server

If your network supports Session Initiation Protocol (SIP), you can connect an IP call with SIP.

In the *IP Network Services* interface, click **SIP Server** to configure SIP server parameters.

IP Network Type :

---

Transport Type :

Register to Server

Primary Server : Disabled

Server Address :

Server Port :

Server Domain Name :

Alternate Server Disabled

Server Address :

Server Port :

Server Domain Name :

User Name :

Password :

Outbound Proxy Server :

Server IP Address :

Server Port :

Figure 11-5 IP Service – SIP Server

Table 11-4 Configuration Description of SIP Server Parameters

Parameter	Description
<i>IP Network Type</i>	<p>Set the IP network type for the RMX 1000 system to make a call. You need to set it based on the call type used for the participant's endpoint. It can be set to:</p> <ul style="list-style-type: none"> <li>▪ <b>H.323:</b> Only H.323 calls are supported.</li> <li>▪ <b>SIP:</b> Only SIP calls are supported.</li> <li>▪ <b>H.323 &amp; SIP:</b> H.323 and SIP calls are supported at the same time.</li> </ul> <p>Settings of the SIP server related parameters are available only when the SIP-supporting network type is selected.</p>
<i>Transport Type</i>	<p>Set the transport layer protocol used for communicating with the SIP server. It needs to be consistent with the protocol supported by the SIP server.</p>
<i>Register to Server</i>	<p>Specifies whether to register RMX 1000 to the specified SIP server. You need to set the SIP server related parameters after this function is enabled.</p>
<i>Primary Server/Alternate Server</i>	<p>Displays the registration status of the SIP server. When registration of the preferred server fails, the alternate server will function as the current in-use SIP server.</p>
<i>Server Address</i>	<p>Provides the IP address of SIP server for registration service.</p>

Parameter	Description
<i>Server Port</i>	Provides the connection port of SIP server for registration service.
<i>Server Domain Name</i>	Provides the domain name of SIP server for registration service.
<i>User Name</i>	User name provided by the SIP server for the registered user.
<i>Password</i>	Password matched with the user name.
<i>Outbound Proxy Server</i>	For communication with the SIP server when the RMX 1000 system is configured on the internal network, an outbound proxy server is required to implement traversal of the firewall/NAT. In this case, you need to set the IP address and port number for the outbound proxy server.

## QoS

Quality of Service (QoS) is very important in transmission of high-bandwidth audio and video data. You can use QoS to test and guarantee the following parameters:

- Average packet delay
- Delay variation (jitter)
- Error rate

In the *IP Network Services* interface, click **QoS** to configure the QoS information.

**Figure 11-6** IP Network Services - QoS

The table below explains the meanings for all QoS parameters.

**Table 11-5** QoS Parameter Settings

Parameter	Description
<i>Enable</i>	Select this option to enable configuration of the QoS settings. When un-checked, the system uses the default QoS settings.

Parameter	Description
Type	<p>DiffServ and Precedence are two methods for encoding packet priority. The priority set here for audio and video packets should match the priority set in the network routers.</p> <ul style="list-style-type: none"> <li>Differv: Select when the network router uses Differv for priority encoding. If this option is selected, enter values in the Audio and Video fields. The value range is 0~63.</li> </ul> <p><b>Note:</b> If you select <b>DiffServ</b> but your router does not support this standard, IP packets queue on the same communication links with data packets. This non-prioritized queueing greatly increases the latency and jitters in their delivery and can negatively impact performance.</p> <ul style="list-style-type: none"> <li>Precedence: Select this option when the network router uses Precedence for priority encoding, or when you are not sure which method is used by the router. Precedence should be matched with <b>None</b> in the <i>Tos</i> field. If this option is selected, enter values in the <i>Audio</i> and <i>Video</i> fields, in the value range of 0~5.</li> </ul> <p><b>Note:</b> Precedence is the default mode as it is capable of providing priority services to all types of routers and is currently the most common mechanism.</p>
Audio / Video	<p>You can prioritize audio and video IP packets to ensure that all participants in the conference hear and see each other clearly.</p> <p>The recommended priority is 4 for audio and video to ensure that the packet delay for both is the same, that audio and video packets are synchronized, and to ensure lip and audio synchronization (lip sync).</p>
Tos	<p>Select the Type of Service (ToS) that defines optimization tagging for routing the conference audio and video packets.</p> <ul style="list-style-type: none"> <li>Delay: The recommended default for video conferencing; prioritized audio and video packets tagged with this definition are delivered with minimal delay</li> <li>None: No optimization definition is applied. This is a compatibility mode in which routing is based on Precedence priority settings only. Select <b>None</b> if you do not know which standard your router supports.</li> </ul>

## Ports

Users can set firewall-allowed ports that are used for multimedia conference calls. In the *IP Network Services* interface, click **Ports** to configure the port information.

Fixed Ports

TCP Ports from :  to

UDP Ports from :  to

Figure 11-7 IP Network Services – Ports

The table below explains the detailed meanings of these parameters.

**Table 11-6** Description of Port Settings

Parameter	Description
Fixed Ports	<p>Specifies whether to define the TCP and UDP ports.</p> <ul style="list-style-type: none"> <li>Leave this check box clear if you are defining a Network Service for local calls that does not require configuring a firewall to accept calls from external entities. When this option is not selected, the system uses the default port range.</li> <li>If the firewall is incompatible with H.323, enable this setting and specify the TCP and UDP port ranges.</li> </ul>
TCP/UDP Ports from	Shows the default TCP/ UDP port range. The user can set the start port number here, and the end port number will be calculated automatically.



If the network administrator does not specify an adequate port range, the system will accept the settings and issue a warning. Calls will be rejected when the MCU's ports are exceeded even if hardware ports are still available on the RMX 1000.

## Email

Users can set the address and account information for outgoing conference notification Emails. In the *IP Network Services* interface, click **Email** to configure the Email information.

**Figure 11-8** IP Network Services – Email

**Table 11-7** Description of Email Settings

Parameter	Description
Email Address	Set the Email address for outgoing Email messages.
SMTP Address	Set the mailbox server address for outgoing Email messages.



Parameter	Description
<i>E-mail Account</i>	Set the user name and password for the Email account.



If you configure the SMTP server address with the domain name, ensure that the DNS-related information is configured.

# IVR Service

RMX 1000 provides a conference Interactive Voice Response (IVR) function which allows conference participants to use an endpoint input device (such as a remote control) to interact with the conference following the voice and onscreen operation prompts used in the conference.

The default IVR information is included in the factory default settings, and the participant will hear the default voice prompts when joining a conference. You can also customize the voice prompts if desired.

To view the IVR settings on the RMX 1000, click **IVR Setting** in the *RMX Management* pane. The IVR list will be displayed in the list pane on the right side, where you can test all the stored voice prompts, switch between different languages, or customize the voice prompts.

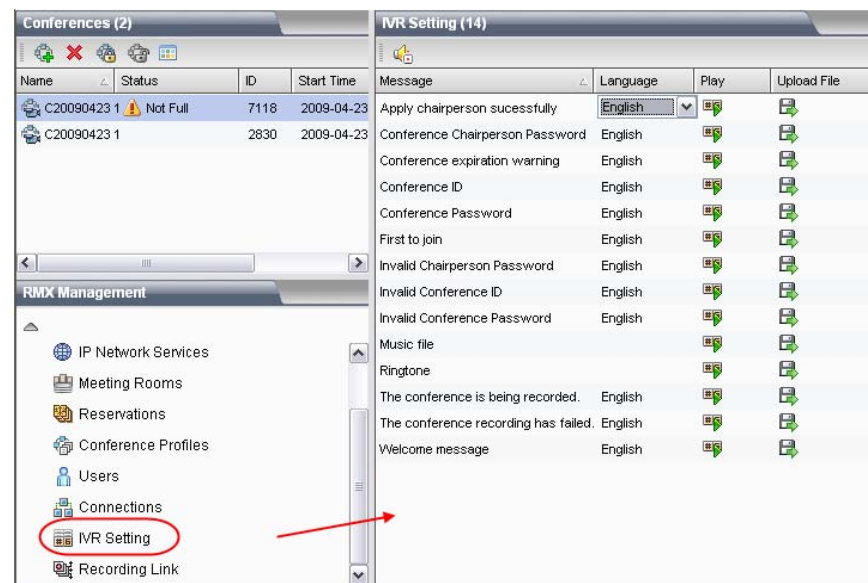

Figure 12-1 IVR Setting Page

## Default IVR Information

The **Message** bar of IVR shows the names of 12 IVR voice prompts available. The table below shows the default IVR information.

**Table 12-1** Factory IVR Information

IVR Information	Prompt Message	Description
<i>Apply chairperson successfully</i>	—	A warning tone will be played when a user successfully applies for the conference chairperson.
<i>Conference Chairperson Password</i>	Please enter the conference chairperson password. Press # when complete.	This prompt will be played when the user attempts to join a conference with a configured chairperson password.
<i>Conference expiration warning</i>	—	A warning tone will be played when the conference is going to be ended due to duration expiration.
<i>Conference ID</i>	Please enter your conference ID. Press # when complete.	This prompt will be played when the participant is required to enter a conference ID.
<i>Conference Password</i>	Please enter the conference password. Press # when complete.	This prompt will be played when the participant attempts to join a password-protected conference.
<i>First to join</i>	You are the first person to join the conference.	This prompt will be played when the first conference participant connects to the conference.
<i>Invalid Chairperson Password</i>	Invalid chairperson password. Please try again.	This prompt will be played if the user enters an invalid chairperson password.
<i>Invalid Conference ID</i>	Invalid conference ID. Please try again.	This prompt will be played if the user enters an invalid conference ID.
<i>Invalid Conference Password</i>	Invalid conference password. Please try again.	This prompt will be played if the user enters an invalid conference password.
<i>Music file</i>	—	This music will be played for the first conference participant until other participants join the conference.
<i>Ringtone</i>	—	A ring tone will be played when dialing out to invite a participant.

IVR Information	Prompt Message	Description
<i>The Conference is being recorded</i>	The conference is being recorded.	This prompt will be played when conference recording begins.
<i>The Conference recording has failed.</i>	The conference recording has failed.	This prompt will be played when conference recording fails.
<i>Welcome message</i>	Welcome to Unified Conferencing.	Each participant to dial into a conference will hear this Welcome message as they enter.

The RMX 1000 shipped with IVR information of three languages: Chinese, English and Japanese. You can click the language options on the **Language** bar to switch between different languages. Click the  button to play the related IVR message.

## Customizing IVR Information

RMX 1000 supports customized IVR prompts. You can upload IVR format-compatible audio files to the device and use personalized voice prompts during conferences.

### Replace the IVR information

To replace the existing IVR information:

- 1 In the IVR list, click the corresponding language option for the IVR message you want to replace, set a target IVR language, and then click the relevant **Upload** button .
- 2 The *Upload File* dialog box pops up. Enter the path to the audio file you want in the file upload path box, or click the **Open** button to set the path, and then click the **Upload** button to upload the file.
- 3 A pop-up box opens and prompts you to reboot. You need to reboot the device for all newly uploaded audio files to take effect.

Click the confirmation button to reboot your device. After the files are uploaded successfully and the device is rebooted, you can click the corresponding **Play** button  to test and play the prompt voice in order to verify if the file replacement is successful.



When uploading an IVR file, the file name is restricted to alphanumeric characters, the file format is restricted to PCM only, and the sampling frequency must be 16 or 32 KHz, 16bit, and stereo or mono.

## Recording an Audio Message

You can record voice messages for different languages or customize them to your needs for IVR service.

To record audio messages, use any sound recording utility available in your computer or record them professionally in a recording studio. Make sure that recorded message can be saved as a Wave file (\*.wav format) and that the recorded format settings are defined as the sampling frequency of 16 KHz or 32 KHz, 16 bit, and stereo or mono. The files are converted into the RMX internal format during the upload process. This section describes the use of the Sound Recorder utility delivered with Windows 95/98/2000/XP.

Make sure that a microphone or a sound input device is connected to your PC.

**To define the format settings for audio messages:**



The format settings for audio messages need to be set only once. The settings will then be applied to any new audio messages recorded.

- 1 On your PC, click **Start -> Programs -> Accessories -> Entertainment -> Sound Recorder**. The *Sound–Sound Recorder* dialog box opens.

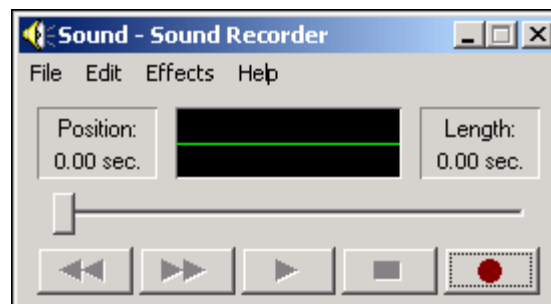

**Figure 12-2** *Sound–Sound Recorder Dialog Box*

- 2 To define the recording format, click **File -> Properties**. The *Properties for Sound* dialog box opens.
- 3 Click the **Convert Now** button.

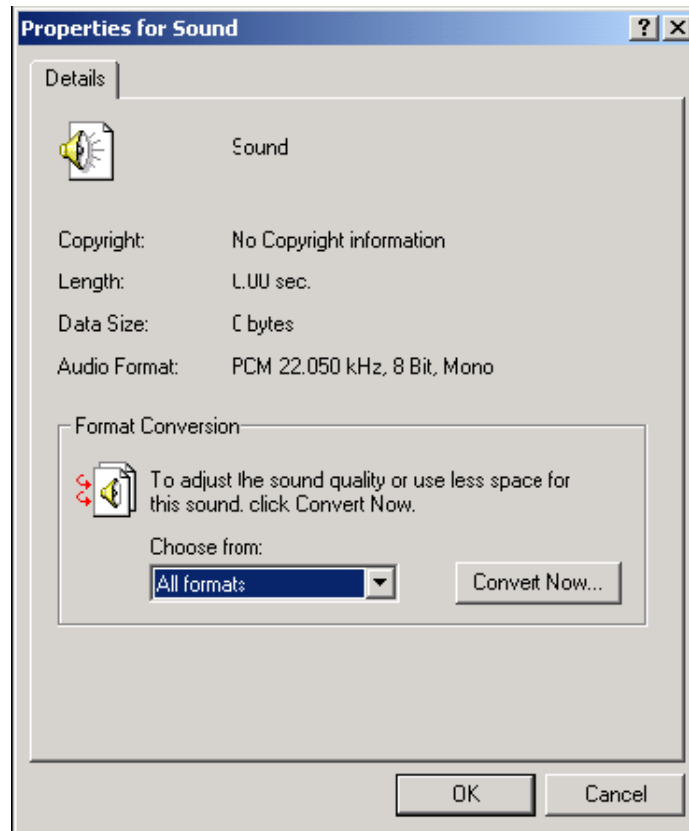

Figure 12-3 Properties for Sound Dialog Box

- 4 The *Sound Selection* dialog box opens.
- 5 In the *Format* field, select PCM.
- 6 In the *Attributes* list, select **16 / 32kHz, 16 Bit** and **Stereo** or **Mono**.

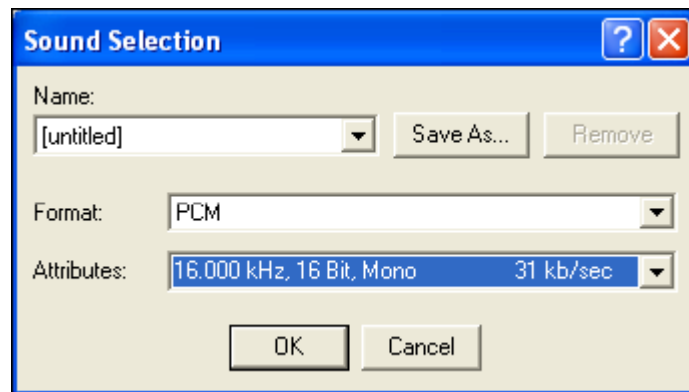

Figure 12-4 Sound Selection Dialog Box

- 7 To save this format, click the **Save As** button. The *Save As* dialog box opens.
- 8 Select the location where the format will reside, enter a name and then click **OK**.

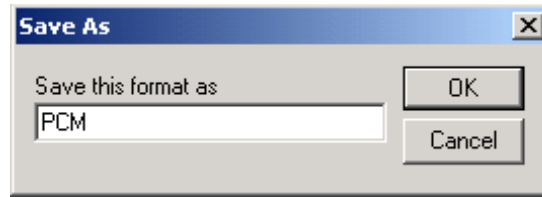

Figure 12-5 Save the Format

- 9 The system returns to the *Sound Selection* dialog box.
- 10 Click **OK**. The system returns to the *Properties for Sound* dialog box.
- 11 Click **OK**. The system returns to the *Sound – Sound Recorder* dialog box. You are now ready to record your voice message.

**To record a new audio message:**

- 1 On your PC, click **Start -> Programs-> Accessories -> Entertainment -> Sound Recorder**. The *Sound-Sound Recorder* dialog box opens.
- 2 Click **File -> New**.
- 3 Click the **Record** button. The system starts recording.
- 4 Narrate the desired message.
- 5 Click the **Stop Recording** button.
- 6 Save the recorded message as a wave file, click **File > Save As**. The *Save As* dialog box opens.

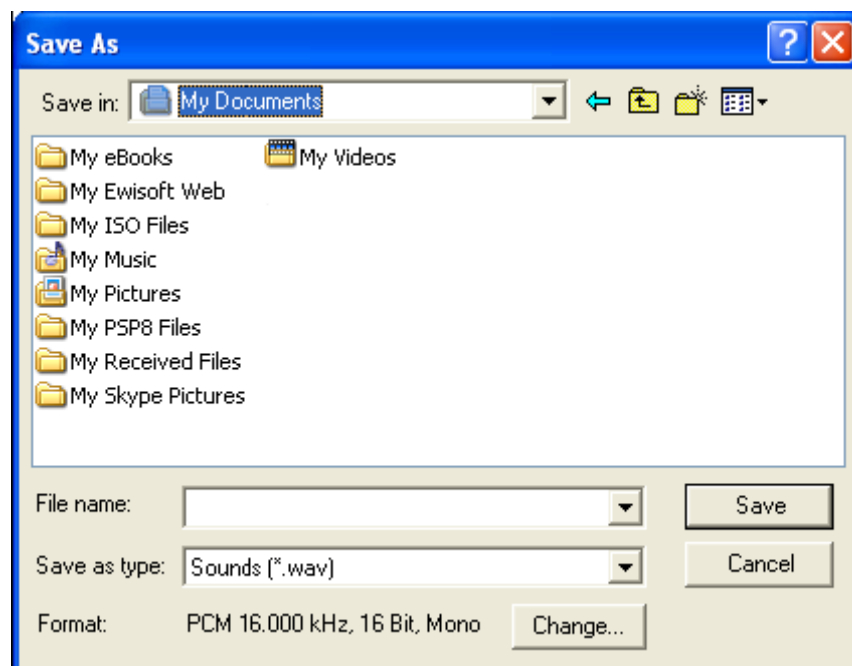

Figure 12-6 Save the Recorded Message

- 7 Verify that the Format reads: PCM 16.000 kHz or 32.000 kHz, 16 Bit, Stereo or Mono. If the format is correct, continue with step 10. If the format is incorrect, click the **Change** button. The *Sound Selection* dialog box appears.
- 8 In the *Name* field, select the name of the format created in step 7, as

shown in Figure 12-5.

- 9 Click **OK**. The system returns to the *Save As* dialog box.
- 10 In the *Save in* field, select the directory where the file will be stored.
- 11 In the *Save as Type* field, select the **.wav** file format.
- 12 In the *File name* box, type a name for the message file, and then click the **Save** button.

To record additional messages, repeat the above steps.

To upload your recorded \*.wav file to RMX 1000, see *Replace the IVR information*.



As participants will access the onscreen UI by calling the RMX 1000 IP address, there are no configurable **Video Slide** options comparable to those available on other Polycom MCU products.





## CDR

RMX 1000 includes a Call Detail Record (CDR) utility, which enables you to view summary information about conferences, as well as to retrieve full conference information and archive it to a file. The file can be used to produce reports or can be exported to external billing programs.

The Polycom RMX can store details of up to 1000 conferences. When this number is exceeded, the system overwrites conference data, starting with the oldest conference.

Each conference is a separate record in the MCU memory and archived as a separate file. Each conference CDR file contains general information about the conference, such as the conference name, ID, start time and duration, as well as information about events occurring during the conference, such as adding a new participant, disconnecting a participant, or extending the length of the conference.

### CDR Files

The conference CDR records can be retrieved and archived in the following two formats:

- Unformatted data – Unformatted CDR files with the suffix .cdr contain multiple records in raw data format. The first record in each file contains general conference data. The remaining records contain event data, one record for each event. Each record contains field values separated by commas, as shown below. This data can be transferred to an external program such as Microsoft Excel© for billing purposes.

```
1,1111,de11eb2f47f2dc1195fd6cdf12605721,2008.03.15,04:20:47,1,2358,2,1,0,0,0;
1,15.03.2008,04:20:47,0,0,0,768,0,255,3,255,255,255,0,0,0;
2001,15.03.2008,04:20:47,0,3,0,0,5,0,255,1,0,1,0,0,1,0,1,0,0,0,65535,65535,65535,65535,65535,65535,65535,65535,65535,65535;
3,1,0,1,0,0,0,4294967295;
5001,15.03.2008,04:20:47,0,1111,1,1,,,,;
7,15.03.2008,04:22:52,0,K60v2A,a688552247f2dc1195fdaa81ab5a5cbf,1,0;
7,15.03.2008,04:29:58,0,K60v2A,a688552247f2dc1195fdaa81ab5a5cbf,1,0;
101,15.03.2008,04:59:55,0,,K60v2A,0,a688552247f2dc1195fdaa81ab5a5cbf,0,255,0,1,0,0,0,1,0,0,2,1;
2101,15.03.2008,04:59:55,0,2,1,0,255,5,2,1,1,4294967295,3232196376,65535,7,103166;
17,15.03.2008,04:59:55,0,K60v2A,a688552247f2dc1195fdaa81ab5a5cbf,1,0,0,0;
18,15.03.2008,04:59:55,0,K60v2A,a688552247f2dc1195fdaa81ab5a5cbf,5,0,255,0,1,0,0,0,1,0,0,2,1,2,1,0,255,5,
2,1,1,4294967295,3232196376,65535,7,103166;
7,15.03.2008,05:00:05,0,K60v2A,a688552247f2dc1195fdaa81ab5a5cbf,2,0;
2,15.03.2008,05:00:05,0,2;
100,15.03.2008,05:00:05,0,;
```

*Figure 13-1 CDR File – Unformatted*

- Formatted text – Formatted CDR files use the suffix .txt. Different from the unformatted CDR, the field value of each data in the formatted CDR file matches its property name one by one, as shown below. This data can be used to generate a summary report for a conference.

```
File Version: 1Conference Name: 1111Internal Conference ID: dell1eb2f47f2dc1195fd6cd12605721Reserved
Duration: 04:20:47Actual Start Time: 1Actual Duration: 2358Status: Terminated by a userFile Name: 1GMT
Offset: 0File Retrieved: YesCONFERENCE START15.03.2008,04:20:47Stand By: FalseAuto Terminate: NoLine Rate:
768 kbpsAudio Algorithm: AutoVideo Session: Continuous PresenceVideo Format: AutoCIF Frame Rate: AutoQCIF
Frame Rate: AutoCONFERENCE START CONTINUE 115.03.2008,04:20:47Entry Tone: ONExit Tone: ONEnd Time Alert Tone:
OFFTalk Hold Time: 0 x 0,01 secondsAudio Mix Depth: 5Video Protocol: AutoMeet Me Per Conference: Yes
Chairperson Password: 1Cascade Mode: NoneMinimum Participants: 0Allow Undefined Participants: YesTime Before
First Participant Joins: 0 minutesTime After Last Participant Quits: 0 minutesConference Lock Flag: NoMaximum
Participants: AutoMessage Service Type: IVRIVR Service: Conference IVR ServiceLecture Mode Type: NoLecturer:
1Time Interval: 0 secondsLecturer View Switching: FalseCONFERENCE START CONTINUE 415.03.2008,04:20:47
Conference ID: 1111Conference Password: 1Chairperson Password: 1Info1: Info2: Info3: Billing Info:
PARTICIPANT DISCONNECTED15.03.2008,04:22:52Participant Name: K60v2AParticipant ID:
a688552247f2dc1195fd6cd1195fdaa81ab5a5cbfDisconnection Cause: Participant hung upQ931 Disconnection Cause: Default
cause or not available (0)PARTICIPANT DISCONNECTED15.03.2008,04:29:55Participant Name: K60v2AParticipant ID:
a688552247f2dc1195fd6cd1195fdaa81ab5a5cbfDisconnection Cause: Participant hung upQ931 Disconnection Cause: Default
cause or not available (0)USER ADD PARTICIPANT15.03.2008,04:59:55User Name: Participant Name: K60v2A
Participant ID: 0Dialing Direction: Dial outNetwork Service Name: Default IP ServiceAudio Only: No
Identification Method: Calling IP address or aliasMeet Me Method: MCU-ConferenceUSER ADD PARTICIPANT CONTINUE
115.03.2008,04:59:55Network Type: H.323Video Protocol: AutoBroadcasting Volume: 5Undefined Participant: Yes
Node Type: TerminalVideo Bit Rate: AutoIP Address: 192.167.103.24Signaling Port: IgnoreH.323 Participant
Alias Type: E.164H.323 Participant Alias Name: 103166H323 PARTICIPANT CONNECTED15.03.2008,04:59:55Participant
Name: K60v2AParticipant ID: a688552247f2dc1195fd6cd1195fdaa81ab5a5cbfParticipant Status: ConnectedNEW UNDEFINED
PARTICIPANT15.03.2008,04:59:55Participant Name: K60v2AParticipant ID: a688552247f2dc1195fd6cd1195fdaa81ab5a5cbfDialing
Direction: Dial inNetwork Service Name: DefaultAudio Only: NoIdentification Method: Calling IP address or
aliasMeet Me Method: MCU-ConferenceNetwork Type: H.323Video Protocol: AutoBroadcasting Volume: 5Undefined
Participant: YesNode Type: TerminalVideo Bit Rate: AutoIP Address: 192.167.103.24Signaling Port: IgnoreH.323
Participant Alias Type: E.164H.323 Participant Alias Name: 103166PARTICIPANT DISCONNECTED15.03.2008,05:00:05
Participant Name: K60v2AParticipant ID: a688552247f2dc1195fd6cd1195fdaa81ab5a5cbfDisconnection Cause: Disconnected by
the operatorQ931 Disconnection Cause: Default cause or not available (0)CONFERENCE END15.03.2008,05:00:05
Conference End Cause: Terminated by a userOPERATOR TERMINATE CONFERENCE15.03.2008,05:00:05Terminated By:
```

Figure 13-2 CDR File – Formatted

## Viewing CDR Records

To view the conference records, click the menu options **Administration -> CDR** on the top-left of the page. The CDR *List* pane appears, showing the saved CDR records.

Select the files to retrieve and then click 'Get Files'

Display Name	Start Time	Duration	Reserved Duration	Status	File Retrieved
1234	27.03.2009 05:14	00:00:16	02:00:00	Terminated by us	YES
1234	28.03.2009 08:30	00:01:20	02:00:00	Automatically ter	YES
1234	28.03.2009 08:58	00:01:23	02:00:00	Automatically ter	YES
1234	28.03.2009 09:20	00:01:21	02:00:00	Automatically ter	YES
1234	28.03.2009 09:24	00:01:23	02:00:00	Automatically ter	YES
1234	28.03.2009 09:34	00:01:26	02:00:00	Automatically ter	YES
1234	28.03.2009 09:38	00:01:23	02:00:00	Automatically ter	YES
1	27.03.2009 07:41	02:00:00	02:00:00	Terminated wher	NO
1	30.03.2009 08:56	00:10:00	02:00:00	Automatically ter	NO
1	26.03.2009 02:01	00:08:09	02:00:00	Terminated by us	NO
1	26.03.2009 02:11	00:10:00	02:00:00	Automatically ter	NO
1	26.03.2009 03:18	00:10:00	02:00:00	Automatically ter	NO

1/8



Go to:

Refresh List      Select All

Retrieve Formatted      Retrieve

Figure 13-3 CDR Records

**Table 13-1** Parameter Description of CDR

Parameter	Description
<i>Name</i>	Shows the conference name and an icon indicating whether or not the CDR record has been written to the RMX 1000's memory.  - CDR record saved  - CDR record not saved
<i>Start Time</i>	The actual start time for the conference.
<i>Duration</i>	The actual duration of the conference.
<i>Reserved Duration</i>	The reserved duration for the conference. You can check if the conference was extended or shortened by comparing the actual Duration to the Reserved Duration.
<i>Status</i>	Shows the conference status.
<i>File Retrieved</i>	Indicates if the CDR files have been previously retrieved to a text file (Yes/No).

The functions for all these buttons on the page are as follows:

- Refresh List - Refresh the CDR list to show newly created records.
- Select All - Select all CDR records in the list.
- Retrieve Formatted - Save the selected CDR records to a specified location as formatted text (.txt files).
- Retrieve - Save the selected CDR records to a specified location as plain text (.cdr files).
-  - Move the cursor to the lower right corner of the CDR list to activate this hidden control. It is used for page turning, going to a specified page or directly going to the first page/last page.

## Saving CDR Records

To save the CDR records to your local machine:

- 1 Select the records to save from the CDR record list.
- 2 Click the **Select All** button to select all the files. To select multiple files, Ctrl-click or Shift-click the files you want according to the Windows operation.
- 3 Click the **Retrieve Formatted** button or **Retrieve** button, set a target storage path in the pop-up *Save Files* dialog box, and then click **OK** to save the records as formatted/plain text.



# RMX Utilities

## System Alerts

When an error occurs in the system, the *System Alerts* function will be activated. RMX 1000 will record the system alert information and generate a report file in the \*.txt format.

When a system error occurs, the system alert area blinks red until the problem is solved.

To view the system alert, click the blinking **System Alerts** bar on the left-bottom of the page to open the *System Alerts* pane. It shows all the unresolved event information.

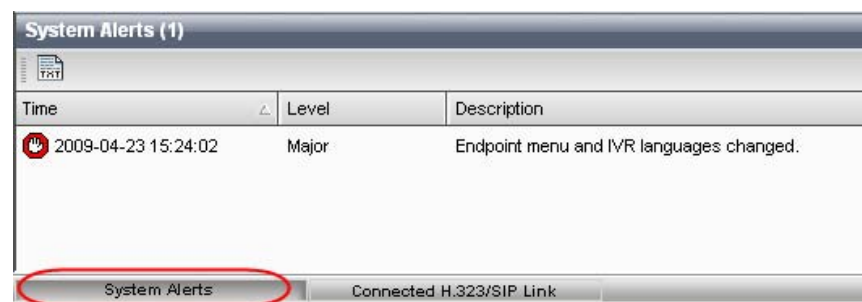

**Figure 14-1** System Alerts

**Table 14-1** System Alert Parameters

Parameter	Description
<i>Time</i>	Shows the date and time when the error occurred. It also shows a severity level identifier for each error (see item Level below)
<i>Level</i>	Shows the severity level of the error (Major, Minor or Startup), each level corresponds to an identifier: <ul style="list-style-type: none"> <li>▪  - Major error</li> <li>▪  - Minor error</li> <li>▪  - Startup error</li> </ul>
<i>Description</i>	Shows the reason of the error with more details

To download the *System Alerts* report file to your local computer, click the button.

## H.323/SIP Link

Name	IP Address	H.323E.164	Connection Time	Room Status	Send Packet Loss	Receive Packet Loss	Audio
HDX 113	172.21.103.113		2009-04-23 15:17:47	C20090423 14:53	0%	0%	Siren22 128K Stereo
sim20_1	172.21.103.20		2009-04-23 14:52:42	C20090423 14:51	9%	0%	G722.1c 48K
sim20_10	172.21.103.20		2009-04-23 14:52:42	C20090423 14:51	5%	0%	G722.1c 48K
sim20_11	172.21.103.20		2009-04-23 14:52:42	C20090423 14:51	5%	0%	G722.1c 48K
sim20_12	172.21.103.20		2009-04-23 14:52:43	C20090423 14:51	9%	0%	G722.1c 48K

Figure 14-2 H.323 Link Status

To view all connected H.323/SIP links, click Connected H.323/SIP Link on the left-bottom of the page.

The H.323/SIP Link pane opens with the list of connected H.323/SIP links. For the meanings of the H.323/SIP link status parameters, see the table below.

Table 14-2 H.323 Link Status Description

Parameter	Description
Name	Participant name or endpoint identifier.
IP Address	The IP address for the participant's endpoint device.
Alias	The alias for the participant's endpoint device.
Connection Time	The date and time when the connection was established.
Status	Shows the meeting room name of the participant. The menu indicates that the endpoint has connected to the PCM (Personal Conference Manager) lobby but hasn't joined any conference.
Send Packet Loss	The packet loss rate of packets sent from the RMX 1000.
Receive Packet Loss	The packet loss rate of packets received from the RMX 1000.
Audio	The audio protocol negotiated with the endpoint
Video	The video protocol and resolution negotiated with the endpoint
H.239	Indicates whether H.239 was negotiated with the endpoint

To disconnect a connected link manually, select the link, and then click the button on the pane.

## System Time

The system clock can be synchronized with the user PC or a network time server to ensure accurate conference scheduling and initiation.

To set the system time, click the menu options **Setup -> RMX Time** on the top-left of the page. The system time setup page opens.



Figure 14-3 System Time Setup Page

This page shows the date and time of the system and the user PC. You can set up the system time in one of the following methods:

- Synchronize with a network time server  
 Select the **Synchronize device time with a time server** option to synchronize the device time with a network time server. In this case, enter the IP address or domain name for the time server in the *Time Server* field, then clicking the Synchronize button to proceed with the synchronization.
- Synchronize with the user PC  
 Select the Synchronize Date & Time on My PC option to synchronize the device time with the connected user PC, then click the **Synchronize** button to proceed with the synchronization.



You cannot perform the time synchronization operation if there is an ongoing conference on the device. You should terminate the conference before activating the Synchronize button.

## Customization

You can customize the following language settings for the device: the language of the menus to be displayed for the endpoints' PCM and the IVR voice prompt language. You can also change the device's system name, customize the user interface and the skin of conference image, etc. To proceed with the customization, click the menu options **Setup -> Customization** on the upper left part of the page to enter the customization page.

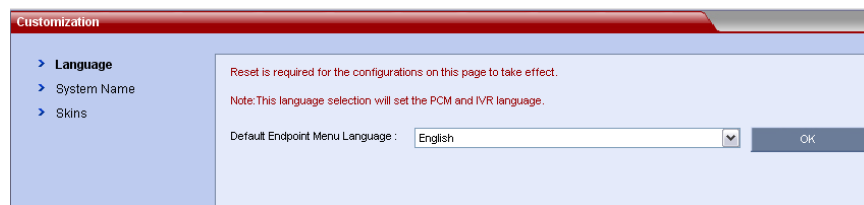

Figure 14-4 Customization Page



## Modifying Language

To modify the device language, click the **Language** tab on the customization page, select the required language from the drop-down menu, and then click the **OK** button. You need to reboot your system to ensure that the settings take effect.



The system provides only the IVR information in English, Chinese and Japanese. If a user selects another language beyond the three, the IVR information in English will be used by default.

## Setting System Name

The system name will be displayed on the endpoint device connected to RMX 1000, with a default name of *POLYCOM RMX 1000*.

To customize the system name for a device, click the **System Name** tab on the customization page, enter the system name in **System Name**, and then click the **OK** button.

## Setting Skins

To customize the Logo for the Web user interface, welcome message on the login interface, or the background of conference screen, click **Skins** in the customization interface.

**Figure 14-5** Setting Skins Page

Set the related items with reference to the table below:

**Table 14-3** Description of Customized Information on User Interface

Customized Item	Description
Web User Interface Logo	Used to customize the Logo picture at the top of the Web management interface of RMX 1000 Click the <b>Open</b> button and select the file to be uploaded. Then, click <b>Upload File</b> . The Logo picture to be uploaded must be in the GIF format, with 1440 * 46 pixels.

Customized Item	Description
<i>Login Screen Welcome Message</i>	Used to customize the <b>Welcome Message</b> displayed on the RMX 1000 Web login interface First specify in the drop-down list which language interface will display this welcome message (defaulted to <b>English</b> ), and then enter the welcome message to be displayed in the text box. Click the <b>Apply</b> button to validate your setting.
<i>Personal Skins</i>	This item is used to customize the background picture of conference view displayed at the participant's endpoint when a conference is held with RMX 1000. Depending on various screen width/height ratios of participants' endpoint displays, you can upload personal pictures that meet different requirements. <ul style="list-style-type: none"> <li>4:3 - You are required to upload pictures in the *.bmp format, with 704 * 576 pixels.</li> <li>16:9 - You are required to upload pictures in the *.bmp format, with 1024 * 576 pixels.</li> </ul> Click the <b>Open</b> button and select the file to be uploaded. Then, click <b>Upload File</b> . After being successfully uploaded, the picture file will be displayed among background pictures on the <i>New Profiles -&gt;Skins</i> interface so that users can select the customized picture as the conference image background, as shown in Figure 14-6.

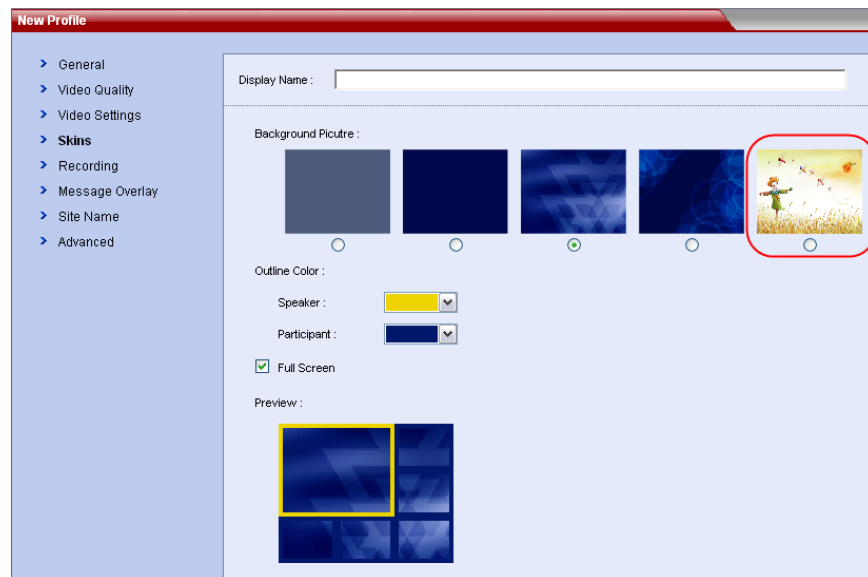

**Figure 14-6** Customizing Background Picture



The file to be uploaded must match the requirements for picture type and size in the system. If the picture fails to meet the requirements, an error message will be displayed. You need not reboot the device after the file is uploaded successfully.

## Security Setting

RMX 1000 provides multiple security setting options. A user can limit the H.323 connection to the device PCM, limit the LAN port that accesses the Web management interface, and configure the Security Socket Layer (SSL) digital certificate to ensure data transfer security at the time of Web communication. Click the **Setup** -> **Security Setting** menu item at the upper left part to enter the *Security Setting* interface.

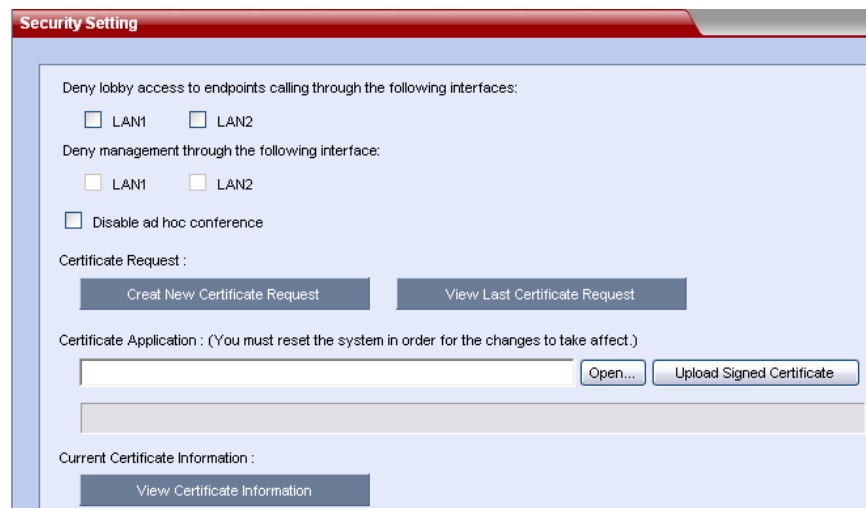

Figure 14-7 Security Setting Page

You can set the following security restrictions:

- **Deny lobby access to endpoints calling through the following interface:** Select the **LAN1** or **LAN2** check box. Then, the endpoint connected to this port cannot dial into the PCM lobby through the IP address or E.164 number of the RMX 1000. However, you can still directly dial in to the conference by calling RMX 1000 IP address/E.164 / SIP URL plus conference ID.
- **Deny management through the following interface:** Select the LAN1 or LAN2 check box. Then, your PC cannot log into the Web UI through the IP address of this LAN port. LAN 1 and LAN 2 ports shouldn't be disabled at the same time. If only one LAN port is enabled, the setting here is not allowed.
- **Disable ad hoc conference:** When this check box is selected, the endpoint cannot create a conference in the PCM lobby. Also, you cannot create a conference by directly entering the IP address or E.164 prefix of RMX 1000 plus conference ID through the remote control.

### Configuring the SSL Certificate

After the SSL digital certificate is installed at the device, you can set up the encrypted communication connection between the user client and server, so as to ensure security of the transferred data during Web communication.

- 1 Create a new certificate request.
- 2 Click **Certificate Request**. In the popup *SSL Configuration* interface, configure the related parameters based on the table below:

**Table 14-4** SSL Configuration for Certificate Request

Parameter	Description
<i>Common Name (CN)</i>	Common certificate name
<i>Organization Name (O)</i>	Name of the organization that issues the certificate
<i>Organization Unit (OU)</i>	Unit of the organization that issues the certificate
<i>Locality Name (L)</i>	Locality or city to which the certificate is applicable
<i>State Name (SN)</i>	State or city/autonomous region to which the certificate is applicable
<i>Country Code (C)</i>	Code of the country that issues the certificate, e.g. the code of China is 086.
<i>Email Address</i>	Email address used to receive and acknowledge the certificate
<i>Days Valid</i>	Valid days of the certificate, in the range of 1-9999999999 days
<i>Key Size</i>	Key size, defaulted to 512 digits. You can select 1024 digits or 2048 digits as needed.
<i>Challenge Password</i>	Certificate request challenge password, which can further strengthen security of the certificate request

- 3 Click **OK** to create the certificate.
- 4 Apply for the certificate.
- 5 Click the **View Last Certificate Request** button to display the information about certificate request just created. Copy the information in the text box to the certificate application page of the certificate issuing organization from which you purchased service. The information will be used to generate a certificate.
- 6 Upload the certificate to the server.
- 7 After obtaining the certificate, click the **Open** button on the interface, select the folder where the certificate file is saved or enter the saving path directly in the left text box, and then click **Upload Signed Certificate** to upload the certificate to the RMX 1000 system.

Click **View Certificate Information** to view the information of the certificate installed at the RMX1000.

Since the HTTPS protocol is used when the SSL security connection is set up between the user client and server, you must enter through the browser **https://IP address of the device** to ensure successful connection if you need to access the Web page of device after the device is installed with the certificate. In addition, you must install the certificate at your local computer as instructed by the popup prompt box. After that, communications between the client and Web server will always be encrypted based on the SSL security connection to ensure security of data transmission.

## SNMP Setting

RMX1000 supports the Simple Network Management Protocol (SNMP). You can monitor the MCU status by managing the workstation.

Click the *Setup ->SNMP Setting* menu item at the upper left part to enter the *SNMP Properties* interface.

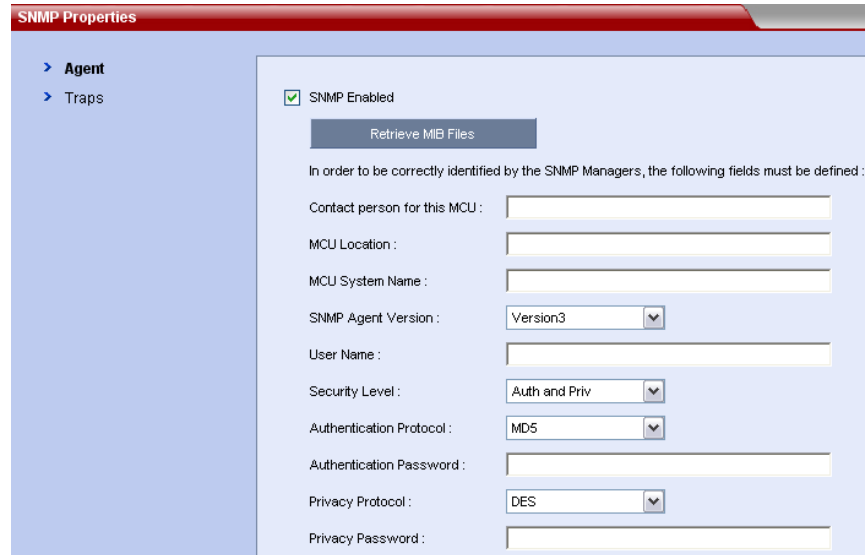

Figure 14-8 SNMP Setting Page - Agent

### Setting the Agent

Configure the following parameters on the *SNMP Properties -> Agent* interface:

Table 14-5 Parameter Configuration of SNMP Agent

Parameter	Description
<i>SNMP Enabled</i>	With this option selected, the administrator is allowed to manage the RMX 1000 system with SNMP from a far end. Only after the SNMP function is enabled, can you configure the following parameters.
<i>Retrieve MIB Files</i>	You can export MIB files by clicking this button.
<i>Contact person for this MCU</i>	Specifies the name of the person who manages this MCU from a far end
<i>MCU Location</i>	Specifies the location of MCU
<i>MCU System Name</i>	Specifies the system name of MCU
<i>SNMP Agent Version</i>	Specifies the SNMP agent version used by MCU <ul style="list-style-type: none"> <li>▪ Version 1 and Version 2 - When this option is selected, you need to configure <b>Community Name</b>.</li> <li>▪ Version 3 - Specifies the parameter settings of secure and remote configuration; when this option is selected, you need to configure <b>User Name</b>, <b>Security Level</b> and related options.</li> </ul>

Parameter	Description
<i>Community Name</i>	Specifies the name of community to which the MCU and SNMP management workstation belongs. The agent to authenticate the SNMP management workstation uses community Name.
<i>User Name</i>	Set the name of user remotely accessed by SNMP.
<i>Security Level</i>	Specifies whether to enable the authentication mechanism and encryption mechanism
<i>Authentication Protocol</i>	Specifies the authentication algorithm. MD5 and SHA are available.
<i>Authentication Password</i>	You can set a password for the authentication protocol to enhance security.
<i>Privacy Protocol</i>	Specifies the encryption algorithm. DES and AES are available.
<i>Privacy Password</i>	You can set a password for the encryption protocol to enhance security.

## Setting Traps

On the *SNMP Properties* interface, click the **Traps** tab to display the *Traps* page.

Trap Community Name

SNMP Trap Version : Version3

Trap Destinations :

User Name :

Engine ID :

Security Level : Auth and Priv

Authentication Protocol : MD5

Authentication Password :

Privacy Protocol : DES

Privacy Password :

Trap Setting

System Alert       Connection

Conference Start/End       New Participant in the Lobby

Figure 14-9 SNMP Setting Page - Traps

Configure the following parameters:

**Table 14-6** Parameter Configuration of SNMP Traps

Parameter	Description
<i>SNMP Trap Version</i>	Specifies the SNMP Trap version used by MCU Version 1 and Version 2 - When this option is selected, you need to configure <b>Trap Destinations</b> and <b>Community Name</b> . Version 3 - Specifies the parameter settings of secure and remote configuration; when this option is selected, you need to configure <b>User Name</b> , <b>Security Level</b> and related options.
<i>Trap Destinations</i>	Specifies sending destinations of SNMP Traps
<i>Community Name</i>	Specifies the name of community to which the MCU and SNMP management workstation belongs. The agent to authenticate the SNMP management workstation uses community Name.
<i>User Name</i>	Set the name of user remotely accessed by SNMP.
<i>Engine ID</i>	Specifies the engine ID of SNMP
<i>Security Level</i>	Specifies whether to enable the authentication mechanism and encryption mechanism
<i>Authentication Protocol</i>	Specifies the authentication algorithm. MD5 and SHA are available.
<i>Authentication Password</i>	You can set a password for the authentication protocol to enhance security.
<i>Privacy Protocol</i>	Specifies the encryption algorithm. DES and AES are available.
<i>Privacy Password</i>	Enter the password of encryption algorithm.
<i>Trap Setting</i>	Specifies whether the agent sends Traps packets to the management workstation in the following cases: <ul style="list-style-type: none"> <li>▪ System alerts</li> <li>▪ Connection</li> <li>▪ The conference starts/ends.</li> <li>▪ A new participant enters the lobby.</li> </ul>

## Product Activation

The Product Activation page is used in the following three activation cases:

- Activate the newly purchased RMX 1000 device.
- Activate payment function items of the RMX 1000, such as H.264, 720p conference, and conference reservation.
- Activate the upgraded device.

Click **Setup** -> **Product Activation** in the menu bar on the top of the Web page. The *Product Activation* page opens, which lists the *serial number*, *current version number*, and other device information.

**Product Activation**

Serial Number : 0004F2BE70C6

Current Running Version : V2.1.0 rev. 14487, Build: Apr 22, 2009

Activation Status :

Uploaded Version : 2.0.0

Minimum Version Requirement : 0.0.0

Activation Key :

Click the button below to register your product at Polycom Resource Center and get an activation code.

**Figure 14-10** Product Activation Page

Fill the activation key obtained from the Polycom Resource Center in the *Activation Key* input box on the page. Then, click the **Save** button to activate the RMX 1000.

After the device is successfully activated, will be displayed at the **Activation Status** property, or else will be displayed. After a payment function of the device is activated, you can see it is activated in the *Administration* -> *License Information* page, as shown below:

**License Information**

Total Number of Resources : Video : 20 Voice : 20

RMX Version : Hardware : 1.1  
Software : V2.1.0-Apr 22, 2009 rev. 14487

RMX1000 Mode : Full Transcoding

Internal Scheduling :

Encryption :

High Definition Continuous Presence(720P) :

Serial Number : 0004F2BE70C6

**Figure 14-11** License Information Page



To directly enter the homepage of the Polycom Resource Center, click the Polycom Resource Center button on the Product Activation page. To obtain the new product activation key, operate according to the procedure of obtaining the payment function activation key. For details, see *Obtaining Product Activation Key* For the method of obtaining the upgrade activation key, refer to *Device Upgrade*.



## Logger Diagnostics Files

The system supports logging and can record and save the system information continually. You can save the log files to your local hard disk for system analysis and diagnosis.

The log program will be activated once the system starts. However, if you manually reboot the system or something goes wrong with the log program (such as a hardware drive error occurs when saving the log files,) the data generated during this period will not be saved.

To view the log files, click the menu option **Administration -> Logger Diagnostics Files** on the top-left of the page. The *log* page appears.

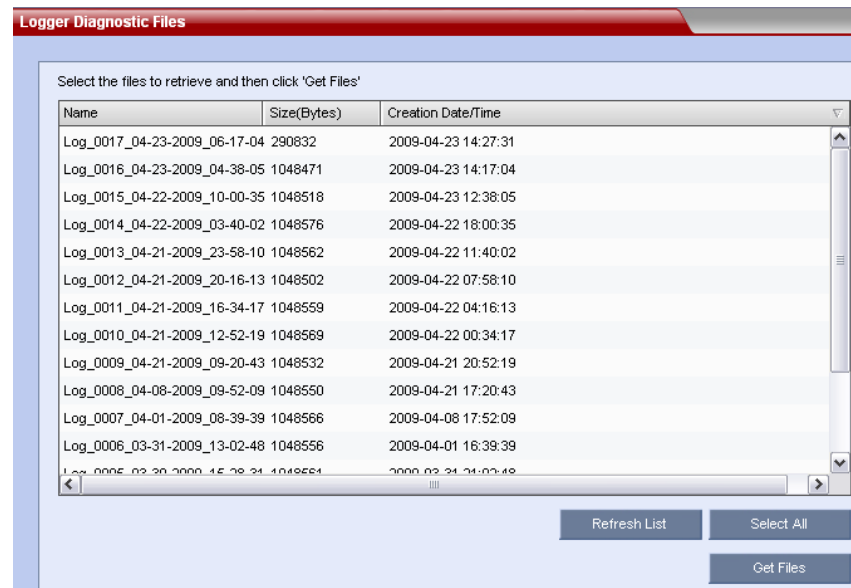

**Figure 14-12** System Log

This page consists of a list of recorded log files with their corresponding creation times and the following function buttons:

- Refresh List - refresh the log list to show the newly created log files
- Select All - select all the log files in the list
- Get Files - save the selected log files to a specified location

To save the log files to a local location:

- 1 In the log list, select the log files to be saved. Click the **Select All** button to select all the files. To select multiple files, Ctrl-click or Shift-click the files you want according to the Windows operation.
- 2 Click the **Get Files** button, set a target storage path in the pop-up **Save Files** dialog box, and then click **OK** to save the files.

## Software Management

You can backup and save all the configurations on the current device to your local PC for future use. You can use the backup configuration file to restore the device configuration if necessary.

## Backup Configuration/Reservation

To backup the configuration for the current device, click the menu options **Administration -> Software Management -> Backup Configuration/Reservation** on the top-left of the page. The *File Download* page appears. Click the **Save** button, and select a saving path to save the current RMX 1000 configuration at the local PC.

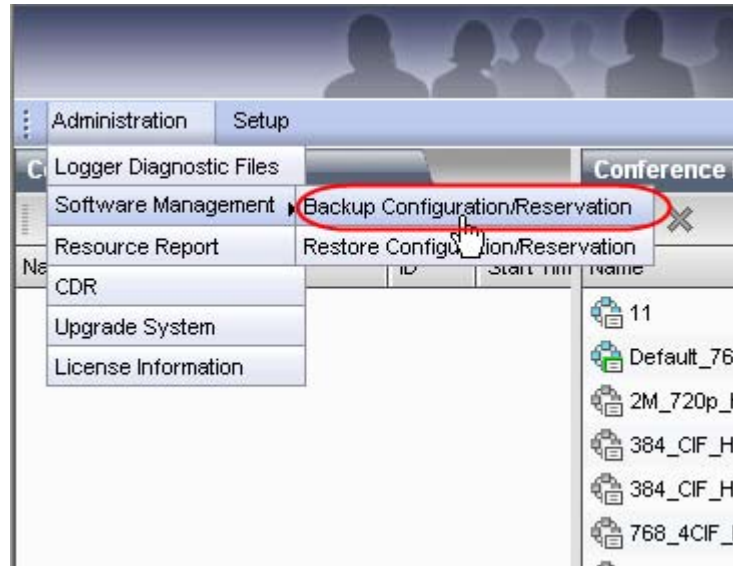

Figure 14-13 Backup Configuration / Reservation

## Restoring Configuration/Reservation

To restore the backup configuration file to the system, click the menu options **Administration -> Software Management -> Restore Configuration/Reservation** at the upper left part on the interface. The *Restore Configuration / Reservation* interface appears.

Enter the path to the configuration file you want or click the **Open** button to select the file, and then click the **Restore** button to restore your configuration. When prompted whether to restart the system, click **Reboot Now** to complete restoring configuration.

To restore the device to the factory settings, select the **Restore Factory Defaults** option, and then click the **Restore** button.

When restoring the system to the factory defaults the following items are saved:

- Current software version
- Key code
- Logs and CDR files
- Certificate or Certificate Signing Request
- Customized login screen welcome message, personal skins and Web UI logo
- IVRs

You may wish to export the address book before you reset the system. See *Importing and Exporting the Local Directory*.



Figure 14-14 Restore Configuration/Reservation Page

## Resources Report

To know the usage of current RMX1000 resources, click the menu options **Administration -> Resources Report** at the upper left part on the interface. The *Resources Report* interface appears.

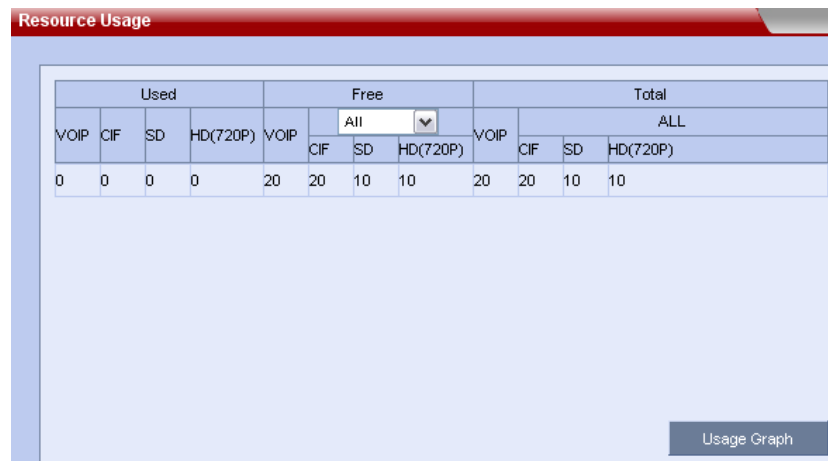

Figure 14-15 Resource Usage

The *Resources Report* page shows usage of audio and video connection resources in the current RMX 1000 system.

Table 14-7 Resources Report

Setting	Description
<i>Used</i>	The item respectively shows the numbers of pure audio, CIF, SD (4CIF/SIF) and HD (720p) connection resources currently used in the RMX 1000 system. "0" indicates that the connection of this audio or video format is unavailable at present.
<i>Free</i>	The item respectively shows the numbers of pure audio, CIF, SD (4CIF/SIF) and HD (720p) connection resources currently available in the RMX 1000 system. You can select a video format from the drop-down list and view the maximum number of connection resources in this video format currently available in the system. "0" indicates that the connection resource of this video format is unavailable already.
<i>Total</i>	This item shows the maximum number of available connection resources in the RMX 1000 system, which is the sum of occupied resources and non-occupied resources.

By clicking the **Usage Graph** button, you can visually view the usage of video and audio connection resources of RMX 1000 within a period through the statistic graph. In addition, you can define the time period for viewing, refresh the statistic graph, and print the statistic graph.

## Device Upgrade

To upgrade the software of your device, click the menu options **Administration -> Upgrade System** on the top-left of the page to enter the system upgrade page.



Figure 14-16 Upgrade System Page

### Upgrading from Version 1.1 to Version 2.1



Please don't restart the system until both the two required packages are uploaded into RMX 1000 successfully. Otherwise the upgrade will failed and cause the unavailability of the Web UI. If that happens, you can use the RMX 1000 Rescue utility provided with the device to restore the upgrade. For details please refer to *System Recovery*.

- 1 Download the required software Version 2.1 (xx-File Systems-xx.ppm and xx-Kernel Systems-xx.ppm) from Polycom web site.
- 2 In the **Upgrade System** page, install the two upgrade packages of software Version 2.1.
- 3 Read the *License Agreement* and select **I Agree** if you accept the terms and conditions.
- 4 Click **Open** to select the *Kernel System* package (.ppm) in the folder where Version 2.1 files are saved and click **Upload File**.
- 5 The system displays "Software upload successfully - reboot system to activate new version now or later?", click **Reboot Later**, **do not restart the system**.
- 6 Continue to upload the *File System* package as described in Step 4.
- 7 When prompted whether to restart the system, click **Reboot Now** to restart your system.

This upgrade requires the installation of an upgrade activation Key. After the system reboot, you need to log into the Web UI to activate the system. Go to

Activating the *Upgraded System* section for further operations.

If the upgrade failed due to restarting the system by mistake, move on to the following section for rescuing information.

## System Recovery



The following step is required before initiating an RMA (Return Material Authorization) or DOA (Damage on Arrival) Process with Polycom Support team.

In the rare scenario where the upgrade fails (Due to the fact that accidentally, a reset was done between the two upgrade files uploading or any other reason), you can restore the upgrade by the following procedures:

- 1 Start up the RMX 1000 system in the rescue mode via HyperTerminal.
- 2 Use the **RMX 1000 Rescue** utility located in the CD (or you can contact Polycom Support team) to reload software packages.

Each of these steps is described in the following sections.

### To start up the RMX 1000 system in the rescue mode:

- 1 Use the RS232 serial cable to connect the serial port of RMX 1000 and the user's PC.
- 2 Run the HyperTerminal in the PC and set the parameters as below:
  - Port: COM1 (confirm on the basis of the port used on the PC)
  - Baud rate: 115200 bps
  - Data: 8
  - Parity: none
  - Stop bit: 1
- 3 In the Console session, press the **Enter** key. The login interface appears. Now enter the login password and press the **Enter** key. The default password is **POLYCOM**(case sensitive).

```
Welcome to Polycom RMX 1000 Console Utility
Copyright (C) 2008 POLYCOM
password: _
```

**Figure 14-17** Console Interface - Login

- 4 Enter the command **Reboot** and then **Y** to confirm. You can also restart

the system manually. When the screen displays message as shown below, **do not press the Spacebar.**

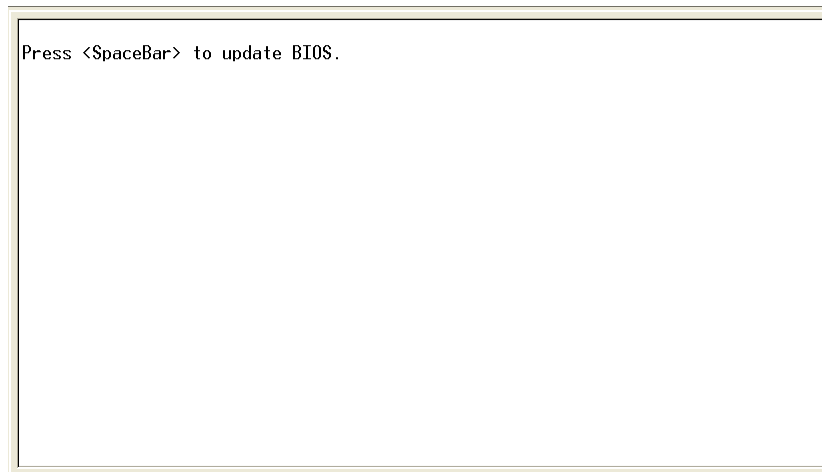

**Figure 14-18** Console Interface – Rebooting

- 5 Wait about 50 seconds, when the screen displays menu as shown below, highlight the **rescue** and press **Enter**.

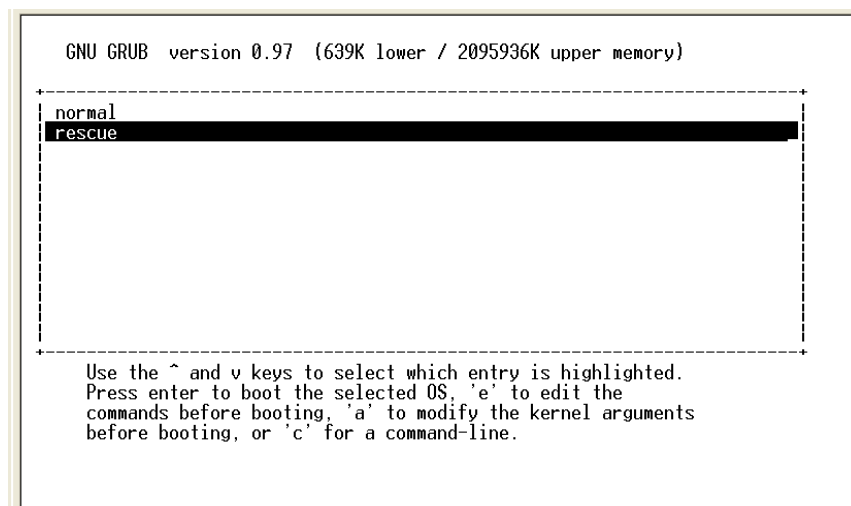

**Figure 14-19** Console Interface – Highlighting Rescue

If you have no operation for 5 seconds on the above interface, the system will automatically enter the normal mode. In that case you need to reboot the system again to recreate the opportunity to select **rescue**.

- 6 The system remains in a startup state for approximately 1 minute. When the screen shows the current system IP address, the system now is running under the rescue mode successfully.

```

EXT3-fs warning: maximal mount count reached, running e2fsck is recommended
EXT3 FS on hda1, internal journal
EXT3-fs: mounted filesystem with ordered data mode.
kjournald starting. Commit interval 5 seconds
EXT3-fs warning: maximal mount count reached, running e2fsck is recommended
EXT3 FS on hda2, internal journal
EXT3-fs: recovery complete.
EXT3-fs: mounted filesystem with ordered data mode.
kjournald starting. Commit interval 5 seconds
EXT3-fs warning: maximal mount count reached, running e2fsck is recommended
EXT3 FS on hda3, internal journal
EXT3-fs: mounted filesystem with ordered data mode.
kjournald starting. Commit interval 5 seconds
EXT3-fs warning: maximal mount count reached, running e2fsck is recommended
EXT3 FS on hda4, internal journal
EXT3-fs: recovery complete.
EXT3-fs: mounted filesystem with ordered data mode.
cat: can't open '/etc/resolv.conf.eth1': No such file or directory
System started.

-----
LAN1 IP: 192.168.1.254/24
-----
.....

```

Figure 14-20 Console Interface –Booting into the Rescue Mode

**To use the RMX 1000 Rescue tool to reload software packages:**

- 1 In the PC used for uploading the software packages, run the RMX 1000 Rescue utility in the CD provided with the product. Please make sure the PC can communicate with RMX 1000.
- 2 In the **Rescue Client for RMX 1000** interface, input the MCU IP address and then click **Browse** button to select *Kernel System* package (.ppm) in the folder where Version 2.1 files are saved.
- 3 Click **Send**, the progress bar will appear indicating the uploading progress if the PC is establishing a connection with the MCU.

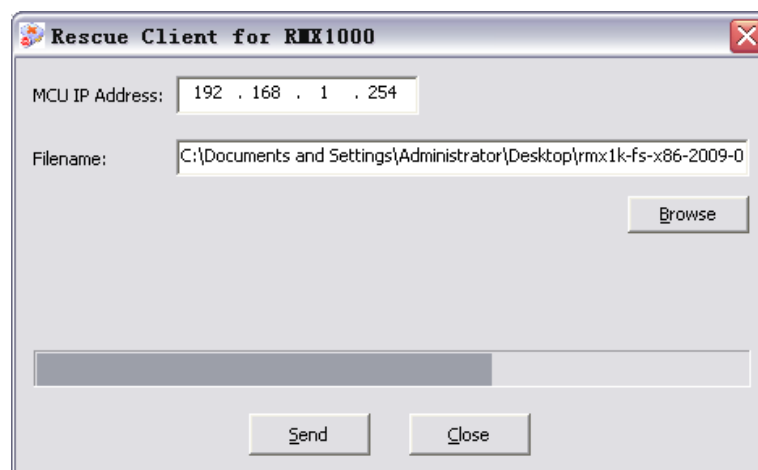

Figure 14-21 Uploading Package

- 4 When prompted whether to restart the system, click **NO** to upload the other package.
- 5 Continue to upload the *File System* package as described in Step 2 and Step 3.
- 6 When prompted whether to restart the system, click **Yes** to complete the upgrade.

## Activating the Upgraded System

- 1 Log in to the Web interface. The system displays the *Product Activation* page, requesting you to enter the activation key to activate the upgraded device. Click the **Polycom Resource Center** button on the page to enter the login page for *Polycom Resource Center*.
- 2 Enter your Email address and password in the login boxes, and then click **Sign In**. If you are a new user, click the **Register for an Account** link to be registered and obtain the login password.
- 3 After successful login, click **Service & Support -> Product Activation -> Overview** in the upper navigation bar on the interface.

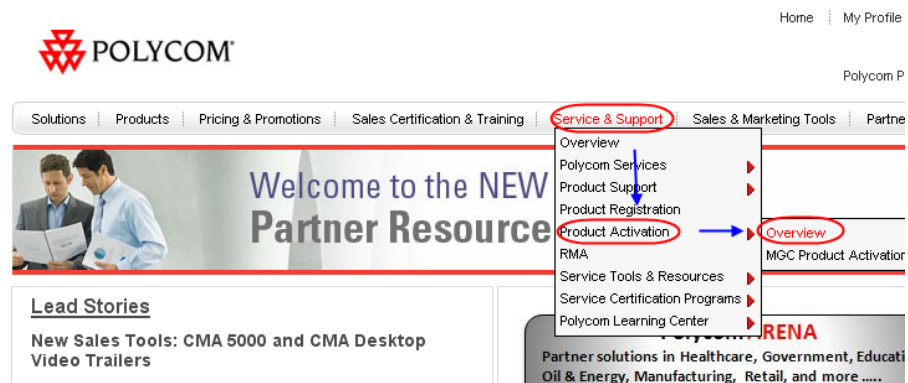

Figure 14-22 Service & Support Interface

- 4 Enter the *Activate Your Product* interface. At the *Software Upgrade Key Code* area, click the **Retrieve Software Key Code** button.
- 5 At the *Single Upgrade Key Code* area, enter the serial number and version number (2.1) of the device, and then click the **Retrieve** button to generate the Key Code required for system upgrade. You can find the serial number of the product from the document provided with the RMX 1000.

### Retrieve Your Upgrade Key Code

**Single Upgrade Key Code**

To retrieve the latest software upgrade Key Code for your system, please enter the complete system Serial Number, the Version Number that you want to install and then click **Retrieve**.

**\*Serial Number:**       **Model:**

**\*Version:**       [Need Help?](#)

Figure 14-23 Retrieve Your Upgrade Key Code Interface

- 6 In the *Product Activation* page, fill the retrieved Key Code in the **Activation Key** input box. Finally, click the **Save** button to activate the RMX 1000.
- 7 After the system reboot, log into the Web UI and go to the *Administration>License Information* page, you will find the software



version number changes to V2.1, and the purchased options are activated.

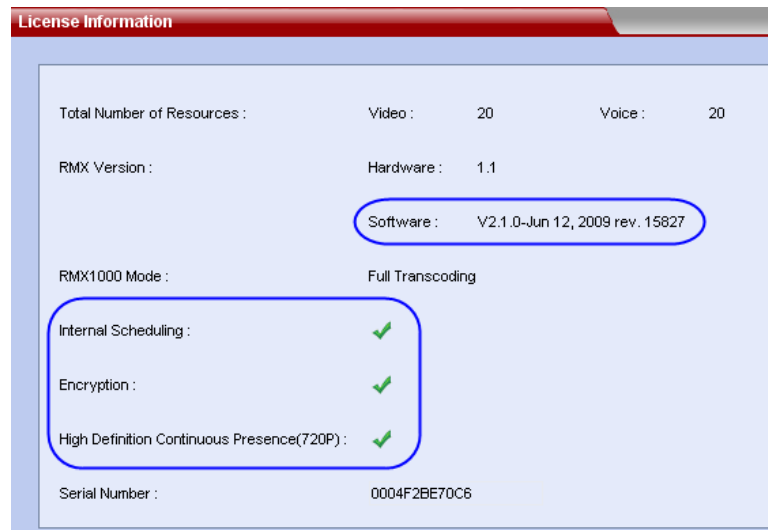

Figure 14-24 License Information

Now, the upgraded device is ready for use.

# Signaling and Hardware Monitoring

## Signaling Monitoring

To monitor the status of LAN1, LAN2, SIP, directory service and gatekeeper of the device you are using, click **Signaling Monitor** in the *RMX Management* pane. The signaling status list will be displayed in the list pane on the right side.

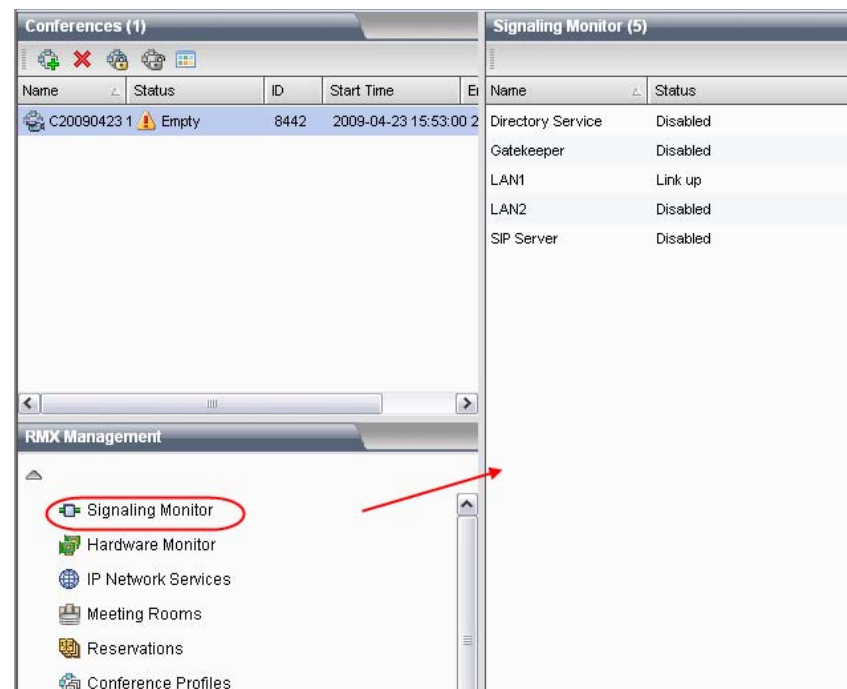

**Figure 15-1** Signaling Monitor Pane

The table below provides the status meanings of related parameters.

**Table 15-1**

Service Name	Status Indication
LAN1 (LAN2)	<p><b>Link up:</b> This network interface has been enabled and connected.</p> <p><b>Link down:</b> This network interface has been enabled but not been connected.</p> <p><b>Disabled:</b> This network interface is not enabled.</p>

Service Name	Status Indication
<i>SIP Server</i>	<b>Registered:</b> MCU has been registered to the SIP server. <b>Registration Failed:</b> Registration of MCU to the SIP server failed. <b>Disabled:</b> Registration to the SIP server is disabled for MCU.
<i>Directory Service</i>	<b>Registered:</b> MCU has been registered to the directory server. <b>Registration Failed:</b> Registration of MCU to the directory server failed. <b>Disabled:</b> Directory service is disabled for MCU.
<i>Gatekeeper</i>	<b>Registered:</b> MCU has been registered to the gatekeeper. <b>Registration Failed:</b> Registration of MCU to the gatekeeper failed. <b>Disabled:</b> Gatekeeper service is disabled for MCU.

To view status details of the LAN1, LAN2, SIP, directory service and gatekeeper, double-click the related list item, or select an option on the right-click menu to enter the property interface.

## Hardware Monitor

To monitor usage of the system CPU, memory and resources of the current device, click **Hardware Monitor** on the *RMX Management* pane. The list pane on the right side lists the status of all hardware components of the device.

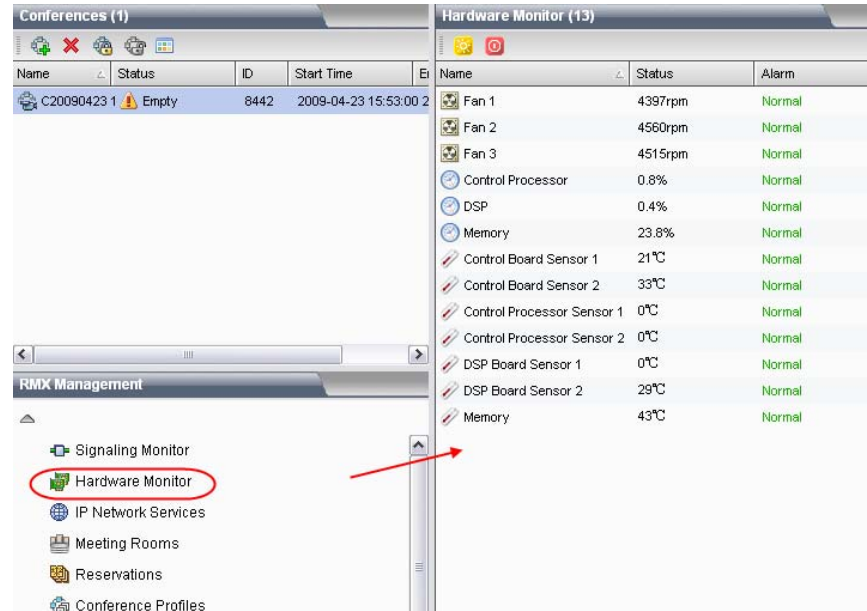



Figure 15-2 Hardware Monitor Pane

The *Status* column lists the current working status of a unit, such as the usage, fan speed and temperature. If the status of a hardware unit goes beyond the normal range, the *System Alerts* area blinks red and displays an alert message. The table below shows the normal operating range of each hardware unit.

**Table 15-2** Normal Range of the Hardware Status

Unit	Normal Range
<i>CPU</i>	0-67 Celsius degree
<i>Motherboard</i>	0-65 Celsius degree
<i>Memory</i>	0-95 Celsius degree
<i>Fan Speed</i>	200-8000 RPM

To reboot the device, click the  button on this pane.

To shut off the device, click the  button on this pane.



---

# Personal Conference Manager (PCM)

In addition to the Web interface, the user can also use the Personal Conference Manager (PCM) interface provided by RMX 1000 to control conferences through the remote control.

The main menu interface from RMX 1000 will pop up after an endpoint dials into RMX 1000 and sets up a connection successfully. With the PCM, the user can easily join a conference, create a new conference, or perform the related conference control operations using the remote control.

Regular participants connected to RMX 1000 have different control permissions from those of the conference chairperson. Regular participants can perform the following conference operations on the endpoint interface:

- Change the screen layout of the endpoint.
- Control the camera of each site from a far end.
- Request the chairperson.

In addition to the operations mentioned above, the chairperson can:

- Connect Participant
- Disconnect Participant
- Check or modify the audio or video session status for each participant's endpoint
- Record a conference.
- Terminate a conference

Next, this chapter will introduce in details the function of each menu option on the PCM interface and related conference operations.

## Introduction to PCM Interfaces

### Viewing the PCM Interface

To establish a call link, use the endpoint to call the IP address for RMX 1000 directly, or call the E.164 prefix or SIP URL of RMX 1000 if you have registered to a gatekeeper or SIM server. After the connection is successfully established, the PCM lobby of RMX 1000 will be displayed on the endpoint, as shown below.

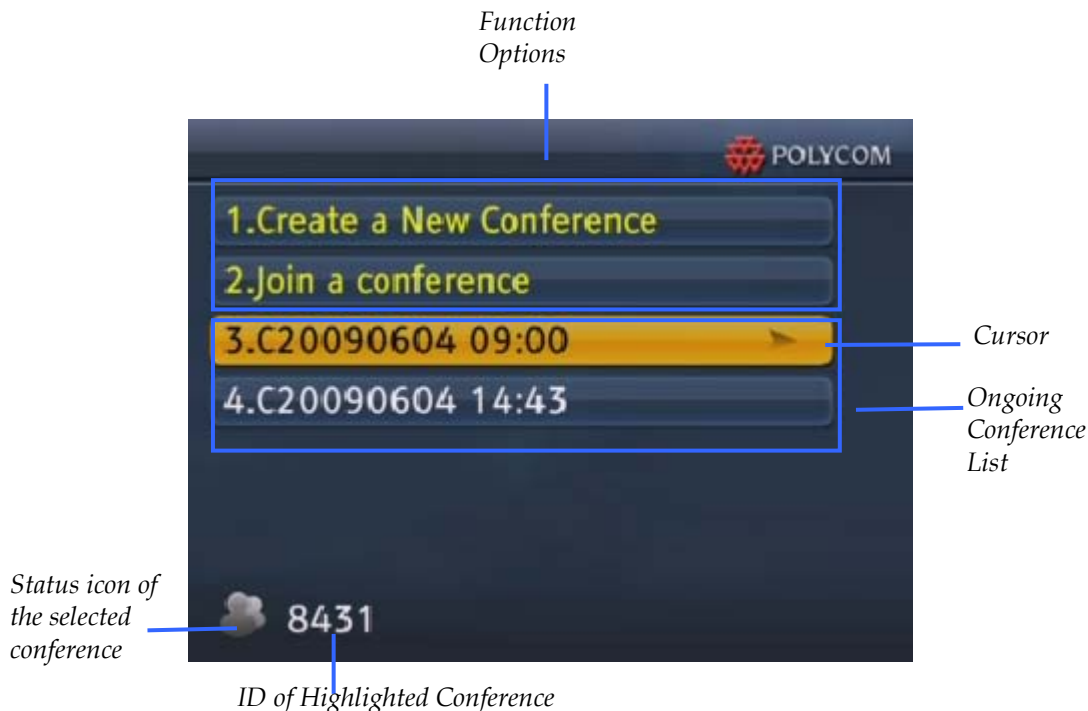







Figure 16-1 Interface of the PCM Lobby

Table 16-1 Description for Conference States

Status	Description
	No participant joins the highlighted conference, and an endpoint can directly access it.
	Some participants have joined the highlighted conference, and an endpoint can directly access it.
	The highlighted conference has a password. You must enter the conference password to join it.
	The highlighted conference is locked and permits nobody to join.
	<ul style="list-style-type: none"> <li>The highlighted conference has a password. You cannot join it through the PCM interface.</li> <li>The current endpoint is unavailable in the participant list of the conference, and this conference is configured with <b>Only participants in the above participant list can dial in</b> (see <i>Participant setup</i>).</li> </ul>

After joining the conference, you can use any arrow key on the remote control to invoke the function menu, so as to perform some specific function operations.



Figure 16-2 Function Menu – Regular Participant Interface



If you have no operation for a certain period on the PCM menu interface, the system automatically goes back to the conference image.

## Definitions of DTMF & FECC Keys

You can control RMX 1000 using FECC and DTMF functions of the remote control. When your endpoint supports FECC or DTMF, use the remote control to operate the PCM menu interface.

On the PCM menu interface, you can select each function menu by pressing the up arrow/down arrow key on the remote control, and go to the next-level page of the highlighted menu item by pressing the right arrow key. If you continuously press the up arrow key or down arrow key, you can cyclically switch between the first menu page and the second menu page. In addition, you can, according to the number of each menu item, press the corresponding number key on the remote control to fast enter this page.

The table below defines in details the FECC and DTMF operation keys on the remote control of Polycom endpoint.

Table 16-2 FECC Control Keys

FECC Token	Description
←	<ul style="list-style-type: none"> <li>▪ Return to the higher-level menu</li> <li>▪ Delete the character before the cursor (while inputting menu names)</li> <li>▪ Exit the menu and display the video (if the top level menu is displayed)</li> <li>▪ Shift the selection to the left video</li> <li>▪ Bring up the menu (if the conference videos are displayed)</li> </ul>



FECC Token	Description
→	<ul style="list-style-type: none"> <li>Go to the lower level menu</li> <li>Confirm the selection (if the menu is displayed)</li> <li>Shift the selection to the right video</li> <li>Bring up the menu (if the conference videos are displayed)</li> </ul>
↑	<ul style="list-style-type: none"> <li>Return to the higher-level menu, if the menu is displayed (cyclic)</li> <li>Shift the selection to the above video</li> <li>Bring up the menu (if the conference videos are displayed)</li> </ul>
↓	<ul style="list-style-type: none"> <li>Go to the lower-level menu, if the menu is displayed (cyclic)</li> <li>Shift the selection to the below video</li> <li>Bring up the menu (if the conference videos are displayed)</li> </ul>
Zoom Out	<ul style="list-style-type: none"> <li>Exit a specific state (under some specific states)</li> <li>Zoom in the focus in the remote camera control state</li> </ul>
Zoom In	<ul style="list-style-type: none"> <li>Confirm the selection (under some specific states)</li> <li>Zoom out the focus in the remote camera control state</li> </ul>

Table 16-3 DTMF Control Keys

DTMF	Description
0	<ul style="list-style-type: none"> <li>Shortcut key (if the conference videos or the menu is displayed)</li> <li>Input numbers (while inputting menu names)</li> <li>Go back to the conference (in the far-end camera control status)</li> </ul>
1 – 9	<ul style="list-style-type: none"> <li>Shortcut key (if the conference videos or the menu is displayed)</li> <li>Input numbers (while inputting menu names)</li> </ul>
*	<ul style="list-style-type: none"> <li>Enable the DTMF function of the Polycom remote control (if the conference video or the menu is displayed)</li> <li>Enter a period "." (While inputting IP addresses to invite participant)</li> </ul>
#	Input confirmation to signify completion



Before using the shortcut number keys 0-9, enable the DTMF function of the endpoint according to that endpoint's configurations.

## PCM Operations

### Creating a Conference

To create an instant conference:

- 1 In the PCM lobby, press the up arrow/down arrow key on the remote control to select **Create a New Conference**, and then press the right arrow key → to enter the conference creating interface, or directly press the number key "1" to enter the interface.

**Figure 16-5** Create Conference Interface

- 2 Enter the valid conference ID at the cursor, and press # to confirm. You can press the left arrow key ← to delete the content just entered.
- 3 The cursor moves to the text box of conference password. If necessary, enter the conference password and press # to confirm it.
- 4 If the conference has a password, all the participants attempting to connect to the conference must enter a correct password before joining the conference. The conference password is not mandatory. Directly press the # key if the password is not required.
- 5 The cursor moves to the text box of chairperson password. If necessary, enter the chairperson password and press # to confirm it.
- 6 The chairperson password is used for identifying the participants who will have access to chairperson services. When connecting to a conference, a participant who has entered the chairperson password will be treated as the conference chairperson by the RMX 1000 and thus granted with the corresponding conference operation permissions. The chairperson password is not mandatory. Directly press the # key if the password is not required.
- 7 After the conference is created, the endpoint that creates this conference will access as the chairperson.



Please make sure that the conference ID entered does not conflict with any currently running conference ID, meeting room ID, or conference reservation ID. Otherwise, the creation of the conference will fail because conference IDs must be unique.

## Entering an Existing Conference

A user can join an ongoing conference in the RMX 1000 system by using one of the following two methods:

### Select the conference to join from the conference list:

- 1 In the PCM lobby, select the conference to join from the conference list by pressing the up arrow/down arrow key on the remote control, and

then press the right arrow key  $\longrightarrow$ , or directly press the corresponding number key of this conference to join it.

- 2 Enter the interface for entering the conference password (if set). Enter the conference password and press # to confirm it. You can press the left arrow key  $\longleftarrow$  to delete the content just entered.
- 3 If the password you entered is not correct, you won't be able to join the conference.

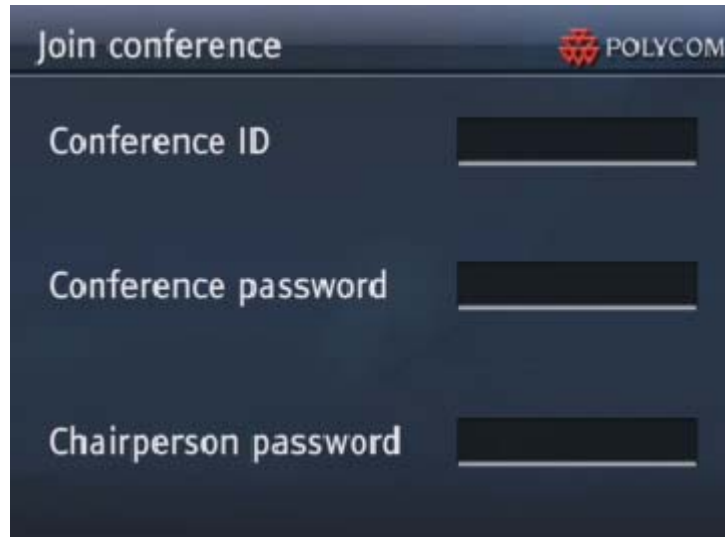

Figure 16-6 Join Conference Interface

- 4 Enter the interface for entering the chairperson password (if set). Enter the chairperson password and press # to confirm it. You can press the left arrow key  $\longleftarrow$  to delete the content just entered.
- 5 If the password you entered is not correct, you won't be able to join the conference. For regular participants, just press # or the right arrow key  $\longrightarrow$  to enter the conference.

**Directly enter the conference ID:**

- 1 In the PCM lobby, press the up arrow/down arrow key on the remote control to select **Join a conference**, and then press the right arrow key  $\longrightarrow$  to confirm, or directly press the number key "2".
- 2 On the conference-joining interface, operations are consistent with those for creating a conference. For details, see *Creating a Conference*.



- If the encryption function is enabled for a conference, you cannot join that conference through the PCM lobby. However, you can directly dial in to the conference by entering the IP address of RMX 1000 plus the conference ID through the remote control of the endpoint. For details, see *Connecting to a Conference - Dialing Methods*.
- If the maximum video connections to the RMX 1000 are already utilized, an additional endpoint can only directly join the conference by calling the conference directly. Attempting to use the PCM lobby will fail, because the lobby cannot be generated by the RMX 1000 when all video resources are full. The endpoint can connect as an audio-only participant, presuming the RMX 1000's audio resources are not also fully utilized.

## Conference Control for Regular Participants

If you enter a conference as a regular participant, please wait until the conference video appears and then press any arrow key on the remote control to open the function menu as shown below.



**Figure 16-7** Conference Control for Regular Participants – Main Menu



If the *Limit Personal Conference Management (PCM) access to conference creator only* option is selected in the conference profile settings page, the regular participants in the conference cannot display the PCM menu to control the conference.

### Click & View















This menu option is used to set the screen layout for a participant’s endpoint.

#### To change the layout on the participant's endpoint screen:

- 1 In the PCM main menu, select **Click & View** to go to the interface for selecting a layout legend.
- 2 Select a layout legend by pressing the up arrow/down arrow key on the remote control, or directly press the corresponding number key of the layout legend number.
- 3 Enter the layout setting status. By repeatedly pressing the right arrow key on the remote control, you can cyclically switch between different layouts of this legend type. For the layouts available for each legend, see *Table 16-4 Layout Control Legends*.
- 4 Press the left arrow key on the remote control for multiple times to exit the layout setting status, and return to the conference image.

**Table 16-4** Layout Control Legends

Legend	Layout States and Function Description

Legend	Layout States and Function Description
	
	
	
	
	
	
	
	Fit the layout to the conference mode you set



- When the conference image appears, press the DTMF combination key “\*\*”\*” through your remote control to open the layout legend selection interface.
- Change layout function is available only if the conference is configured in the Conference Layout mode. When the conference is in the Lecture Mode or Same Layout, this option will not be displayed. For more information about layout mode settings, refer to *Video Settings*.

## Camera Control

A user can control the camera of endpoint's conference site that supports the FECC function from a far end, e.g. turn the camera of the selected conference site to the up, down, left and right directions, and zoom in/out the focus.

### To control the camera from a far end:

- 1 Select **Camera Control** from the PCM main menu.
- 2 Select the site to be controlled by pressing the up arrow, down arrow, left arrow and right arrow keys on the remote control.
- 3 Press the **Zoom In** key to enter the FECC operation status. Now, the  icon appears on the image of the controlled site.
- 4 Turn the direction of the far-end camera by pressing the up arrow, down arrow, left arrow and right arrow keys on the remote control, or press **Zoom In/Zoom Out** to zoom in/out the focus.
- 5 Press the number key 0 on the remote control to quit the far-end control status, and then press the **Zoom Out** key to return to the conference video.



In the FECC status, if you performed no FECC operation in 10 seconds or used the DTMF function, you will be automatically signed out of the FECC state and brought to the conference image.

## Video Force

When the number of participants added to the conference is larger than the number of configured screen windows, this menu item is used to specify a window to display the remained participants in turn. Select the **Video Force** option to enter the menu interface for changing the displayed conference site.

The selected conference site is displayed with a yellow border around it. You can use the FECC up/down/left/right arrow keys to select the conference site you want, and then press **Zoom In** to confirm your selection. Press **Zoom In** repeatedly to switch the conference videos consecutively.

If you performed no operation in 10 seconds, the endpoint will automatically return to the conference video state. You can also press the **Zoom In** key to exit the *Video Force* interface and return to the main function menu.

## Become Chairperson

After requesting the chairperson successfully, a regular participant will have more control privileges, e.g. invite or disconnect a participant, view and control the audio and video status of a participant, terminate a conference, and control recording.

**To become the chairperson:**

- 1 Select **Become Chairperson** from the PCM main menu, and press the right arrow key to confirm.
- 2 The interface for entering the chairperson password appears. Enter the chairperson password of the conference, and then press # to confirm. If the conference has no chairperson password, directly enter # to become the chairperson.

## Chairperson Conference Control

If you enter the conference as the conference chairperson, wait for the conference video to display, and then press any arrow key to open the function menu as follows. The function menu displayed for the chairperson contains more options than that of the regular participants, as the chairperson has more control ability.



**Figure 16-8** Chairperson Conference Control - Main Menu 1



**Figure 16-9** Chairperson Conference Control - Main Menu 2

For more information about the options shared by the chairperson and the regular participants, please see *Conference Control for Regular Participants*. Only the chairperson-specific functions and operations will be described here.



Currently, the chairperson and regular user menu are fixed and cannot be customized.

## Inviting Participant

When a conference is going on, the chairperson can fast invite a participant to join this conference through the PCM interface.

### To invite a participant to join:

- 1 Select **Invite Participant** from the PCM main menu, and press the right arrow key to confirm.
- 2 Select **Connection Type**, and press the **Zoom In** key to display the list.
- 3 Select a connection type, and press the **Zoom In** key to confirm.
- 4 Call the participant to be invited using one of the following two methods:
  - Manually enter the IP address or suffix of the participant to make a call. This method is applicable when the address of this participant is not added to the system address book. For details of the address book, see *Address Book*.
  - a Select the text box, and enter the IP address of the participant's endpoint through number keys on the remote control. If a gatekeeper is registered, you need to enter the E.164 number of the endpoint.
  - b Press the # key to initiate the call.
  - If the IP address of the participant to be invited exists in the address book, you can directly select this participant from the address book to make a call.







- a Select the **Directory** menu option to enter the directory interface. The list displays by default the address book entries added by users through the local computer.
- b The chairperson can display addresses in the local and global directories by category through the drop-down menu on the interface, and manually enter the participant name to search directly or select the alphabetic or numerical range for filtering according to the initial character of the name. On this interface, press the **Zoom In** key to confirm the operation.
- c Select a participant to be invited from the list by pressing the up arrow, down arrow, left arrow and right arrow keys on the remote control, and press the **Zoom In** key to initiate a call.

### Participant mute/status

A user can view and control the audio and video status of each participant's endpoint. Select **Participants Mute/Status** from the PCM main menu, and press the right arrow key to enter the interface for controlling the audio and video of participants' endpoints and viewing the status, as shown below.

The interface lists the mute, blocking and video suspending status of all participants' endpoints. The conference chairperson can select a status icon by pressing the up arrow, down arrow, left arrow and right arrow keys on the remote control, and then press the **Zoom In** key to switch this status (repeatedly press the **Zoom In** key to cyclically switch the on/off status). The table below provides the meanings of status icons. **ALL** can be selected to mute and unmute all the endpoints except the conference chairperson's and the lecturer's.

**Table 16-5** Status Legend Descriptions

Legend	Description
	The audio output to the endpoint is allowed. Other conference participants can hear the audio from this endpoint.
	The endpoint is MUTED. Other conference participants will hear this endpoint.
	The audio input from the endpoint is allowed. This endpoint can hear the audio from other conference sites.
	The audio output to the endpoint is blocked. This endpoint will not hear the audio from other participants.
	The video output of the endpoint is allowed. Other conference participants can see the image of this endpoint.
	The video transmission from the endpoint is blocked. Other conference participants will not see this endpoint.
	This icon is displayed when the endpoint is neither muted nor suspended. You can click this icon to mute this endpoint and prevent it from sending video data to other conference sites.



## Recording a Conference

When a recording link has been set up in the conference, the conference chairperson can start recording, suspend recording, and stop recording through the PCM interface. For details of Recording Link, see *Recording Link*.

### Start conference recording:

- 1 Enter the second page of the PCM main menu, select **Recording**, and then press the right arrow key to confirm.
- 2 Press the right arrow key on the remote control to start conference recording. Now, the page shows the recording suspending and stopping menu so that you can control the recording process.

## Disconnect Participant

### Disconnect Participant:

- 1 Select **Disconnect Participant** from the PCM main menu, and press the right arrow key to confirm.
- 2 Select the participant to be disconnected by pressing the up arrow key and down arrow key on the remote control, and press the right arrow key to confirm.

## Terminate Conference

### Terminate Conference:

- 1 Select **Terminate Conference** from the PCM main menu, and press the right arrow key to confirm.
- 2 The interface displays the prompt message for confirming deletion. Press the left arrow key to cancel, or press the right arrow key to confirm the deletion.

# Appendix A: Connection Failure Diagnosis

When a participant failed to connect to a conference or was disconnected from a conference, the *Connection Status* page of *Participant Properties* pages appears, listing the cause and more details about the connection failure. When possible, it also provides you the possible solutions.

This appendix lists the causes that may be shown in Call Disconnected Cause and the corresponding descriptions.

**Table 17-1** Description for Disconnection Failure

Parameter	Description
<i>CALL_REJECT_GK</i>	Call rejected by the gatekeeper
<i>NO_NET_CONNECTION</i>	Network connection failed
<i>RESOURCE_DEFICIENCY</i>	No enough resources
<i>NETWORK_ERROR</i>	Network error
<i>CALL_REJECT_NO_ANSWER</i>	No answer to the call
<i>CALL_REJECT_BUSY</i>	The line is busy
<i>CALL_REJECT_IMMEDIATELY</i>	Call rejected
<i>NON_ENCRYPT_TERM_JOIN_ENCRYPT_MEETING</i>	Non-encrypted endpoints are not allowed to join an encrypted conference
<i>ENDPOINT_HANGUP</i>	The endpoint hangs up initiatively
<i>Operator_DISCONNECT</i>	Disconnected by the administrator



---

# Appendix B:

## Telnet/Terminal Commands

RMX 1000 also supports device debugging from the command line. You can configure command settings in either of the following two methods: using the HyperTerminal after connecting it to the device through a serial port or configuring via telnet. Both methods use the same command format. Next, we will describe how to configure command setting using the HyperTerminal.

### HyperTerminal Parameters

- Port: COM1 (basing on the port used)
- Baud rate: 115,200 bps
- Data bits: 8 bits
- Parity bit: None
- Stop bit: 1

Furthermore, you may need to set some other parameters based on the simulation software used:

- No echo for local input
- The settings for the DEL and Backspace keys
- Enter/New line
- The simulation type for the endpoint: Automatic or ANSI

### Login

If you have completed all the above configurations and launched the HyperTerminal simulation software successfully, press the **Enter** key. The login interface appears.

The login interface shows all of the software information and you'll be prompted to enter the login password. Now enter the login password and press the Enter key.



The factory default login password is POLYCOM (case sensitive).

If you entered a wrong password, you may be required to re-login to the system.

If you entered the right password, you will be brought directly to the command setting interface.

```
User logged in.

Type ? or help to get the help information

#
```

## Command Introduction

### Help

After logging into the system, you may enter **?** or **help** after the prompt **"#"** to show the command prompt information.

```
# ?
help or ?          Show this message.
exit              Logout.
show             Print the system information.
keepalive <timeout> Get or set the timeout value of Telnet session, default is 2 Minutes.
reboot          Restart system.
reset password   Reset web UI admin password.
reset config     Clean configuration, back to default IP Address.
cleankey        Remove the existing keycode.
telnet <on|off>  Get or set Telnet service status.
lpr <on|off>    Get or set lpr option.
set telnet password Change the Telnet password, Up to 20 characters
ping <ip> <-n <count>> <-w <time>> <-l <size>> A network tool send ICMP ECHO_REQUEST to network hosts.
set <lan1|lan2> ip <dhcp|static <ip> netmask <mask> gw <gateway>> Set ip address of lan1 or lan2.
set <lan1|lan2> speed <auto|1000|100 full|100 half|10 full|10 half> Set duplex speed of lan1 or lan2.
```



- “<>” indicates an optional parameter
- “{}” indicates a required parameter
- “|” indicates a 1-out-of-N parameter

### Exit

Enter **exit** after the prompt **#** to exit the command control interface.

```
# exit

User logged off
```

## View Device Information

Enter **show** after the prompt **#** to view the current device information, including the system information, license information, interface information and IP address.

## Idle Timeout Setting

Enter **keepalive<timeout>** after the prompt **#** to modify the keep-live timeout setting. If no operation was executed in the defined time interval, the device will time out and exit.

**Table 18-1** Parameters Description

Parameter	Description
timeout	Defaults to 120 seconds and can be modified to any value in the range of 5 – 600 seconds

[Example] Set the timeout time to 60 seconds:

```
# keepalive 60
current keepalive timeout value is 60 seconds
```

## Reboot Device

Enter **reboot** after the prompt **#** to reboot the device.

```
# reboot
restart system ...
```

## Restore Password

Enter **reset password** after the prompt **"#"** to restore the user password for Web login to the default password (POLYCOM). The system will display the prompt "Are you sure?", Enter "Y" to continue, or enter "N" to cancel.

After resetting the password, the RMX 1000 must be restarted in order for the new settings to take effect.

[Example] Restore the Web login password to the default configuration:

```
# reset password

Are you sure? [Y for yes / N for no]Y

reset password ... OK

Reboot is require in order for the change to take affect - Reboot now? [Y for y
es / N for no]_
```

## Restore System Configuration

Enter **reset config** after the prompt **"#"** to restore the system to the default configuration. The system will display the prompt "Are you sure?", Enter "Y" to continue, or enter "N" to cancel.

After resetting the system configuration, the RMX 1000 must be restarted in order for the new settings to take effect.

### Clean Key Code

Enter **cleankey** after the prompt "#" to remove the existing key code. This command is used to deactivate the RMX 1000.

The system will display the prompt "Are you sure?", Enter "Y" to continue, or enter "N" to cancel.

### Telnet Setting

Enter **telnet {on | off}** after the prompt "#" to turn on/off the telnet session. For example, enter **telnet on** to enable the telnet function.



The default setting is **telnet on**. If entering "telnet off" to disable the RMX 1000's telnet function, the user can only use the serial port to perform system setting tasks. The default telnet port is 23, which cannot be modified. The password and command operations for remote telnet login are identical to those for serial port login.

### LPR Setting

Enter **lpr {on | off}** after the prompt "#" to enable or disable the packet loss recovery mechanism. The default setting is off.

For example, enter **lpr on** to enable the packet loss recovery function. The data is restored when packet loss occurs during the network transmission.

The system must be restarted in order for the new settings to take effect after changing the LPR setting.

### Password Modification

Enter **set telnet password** after the prompt "#" to modify the login password for the command setting interface.

The password can be set to a maximum of 20 characters. This command is only used to change the login password for the telnet session and serial interface. No effect for the web UI password.

```
# set telnet password
enter new password: _
```

### Ping

Enter **ping <ip> {-n<count>} {-w<time>} {-l<size>}** after the prompt "#" to check the network connection status.

**Table 18-2** Parameters Description

Parameter	Description
ip	IP address of the destination host
-n<count>	Packet sending times, defaulted to 10
-w<time>	Waiting time, defaulted to 1000 ms
-l<size>	Size of the sent packet, defaulted to 32 bytes

[Example] Send the host whose IP address is 172.21.100.111 a Ping packet with the size of 1500 bytes for five times cyclically. The wait time is 1000 ms:

```
# ping 172.21.100.111 -n5 -w1000 -l1500
Pinging 172.21.100.111 with 1500 bytes, loop 5 times, wait 1000 ms.
1520 bytes from 172.21.100.111 : seq=1, ttl=127, delay=1ms.
1520 bytes from 172.21.100.111 : seq=2, ttl=127, delay=2ms.
1520 bytes from 172.21.100.111 : seq=3, ttl=127, delay=2ms.
1520 bytes from 172.21.100.111 : seq=4, ttl=127, delay=2ms.
1520 bytes from 172.21.100.111 : seq=5, ttl=127, delay=1ms.

send 5 packets, receive 5 packets, lost 0(0.0%) packets.
time is 5005ms, bandwidth is 12.1kbps
```

### Network Setting

Enter the following commands after the prompt "#" to set network configurations:

“set {lan1 | lan2} ip {dhcp | static <ip> netmask <mask> gw <gateway>}” - set the IP address for LAN 1 or LAN 2.

“set {lan1 | lan2} speed {auto | 1000 | 100 full | 100 half | 10 full | 10 half}” - set the connection features for the LAN 1 or LAN2 interface.

**Table 18-3** Network Setting Parameters – LAN Interface IP Address

Parameter	Description
dhcp	Automatically gets the address information through the DHCP server.
static	Specifies the static IP address information - ip: IP address of the network port mask: subnet mask of the network port gateway: gateway address of the network port

**Table 18-4** Network Setting Parameters – LAN Interface Connection Rate

Parameter	Description
auto	Auto negotiation mode
1000	1000Mbps
100 full	100Mbps full duplex



Parameter	Description
100 half	100Mbps half duplex
10 full	10Mbps full duplex
10 half	10Mbps half duplex

[Example 1] Set the IP address of the LAN1 interface to 172.21.103.29, subnet mask to 255.255.255.0, and the gateway address to 172.21.103.254:

```
# set lan1 ip static 172.21.103.29 netmask 255.255.255.0 gw 172.21.103.254

Reboot is require in order for the change to take effect. Reboot now? [Y for yes
 / N for no]Y

restart system ...
```

[Example 2] Set the 100M half duplex for the LAN1 interface:

```
# set lan1 speed 100 half

Reboot is require in order for the change to take effect. Reboot now? [Y for yes
 / N for no]Y

restart system ...
```



After you set the connection feature or IP address for the LAN interface, the system must be restarted in order for the new settings to take effect.

## Appendix C: Glossary

Abbreviation/Term	Explanation
<i>Bandwidth</i>	Defines the information-carrying capacity of a channel. In analog systems, it is the difference between the highest frequency that a channel can carry and the lowest, measured in hertz. In digital systems, bandwidth is measured in bits per second. The larger a connection's bandwidth, the more data can be transmitted in a given amount of time, allowing for greater video resolution and more sites in a conference.
<i>Bps, Kbps</i>	Bits and kilobits per second--a unit of bandwidth--that is the amount of data that can flow during one second over a communications line (using a transmission medium). 1Kbps=1000Bps
<i>CIF, 4CIF, QCIF</i>	Common Intermediate Format, an optional part of the ITU-T's H.261 and H.263 standards. CIF specifies 288 non-interlaced luminance lines that contain 176 pixels. CIF can be sent at frame rates of 7.5, 10, 15, or 30 per second. When operating with CIF, the amount of data to transmit cannot exceed 256K bits. The CIF video format has the capacity to transmit video images of 352x288 pixels at 36.45Mbps and 30 frames per second. A 4CIF format has four times the capacity of CIF; QCIF has quarter the capacity of CIF.
<i>Codec</i>	Coder-decoder. A device that converts voice and video into digital code and vice versa. Refers to the endpoint video camera and video board that are used for videoconferencing.
<i>Conference</i>	Connection between two or more endpoints exchanging video and audio information. If only two endpoints are involved, a conference is called point-to-point and no MCU is required. If more than two endpoints are involved, it is called a multipoint conference, and an MCU (Multipoint Control Unit) is required as the management system.
<i>DTMF</i>	Dual Tone Multi-Frequency. A system of coded signals used by touch-tone telephones in which a specific sound, frequency, or tone is assigned to each key so that the signal can be easily recognized by a computer. The codes enable data input and control of voice-processing systems. DTMF signals can pass through the entire connection to the destination device and therefore are used for remote control after the connection with the MCU is established.

Abbreviation/Term	Explanation
<i>Endpoint</i>	A hardware device, or set of devices, that can call, and be called by an MCU or another endpoint. For example, an endpoint can be a phone, a camera, or microphone connected to a PC or conferencing system.
<i>FECC</i>	Far End Camera Control. The accompanying software in certain cameras that enables a participant to control a remote camera.
<i>Frame</i>	A group of bits that make up an elementary block of video data for transmission by certain protocols.
<i>Frame Rate</i>	The number of video frames displayed on-screen during one second, measured in fps (frames per second).
<i>G.711</i>	ITU-T audio algorithm, 64Kbps, 3.4 kHz.
<i>G.722</i>	ITU-T audio algorithm, 64Kbps, 7 kHz.
<i>G.728</i>	ITU-T audio algorithm, 16 Kbps, 3.4 kHz.
<i>Gatekeeper</i>	A type of server that performs two main functions: translates LAN alias addresses of terminals and gateways to IP addresses and provides bandwidth management.
<i>H.221</i>	ITU-T standard that defines how to multiplex video, audio, control, and user data into one serial bit stream.
<i>H.230</i>	ITU-T standard that defines simple multipoint control systems procedures and describes network maintenance functions.
<i>H.231</i>	ITU-T standard that defines a set of MCU functions and operational requirements.
<i>H.242</i>	ITU-T standard that defines initiation of communications between systems and capabilities negotiation procedures.
<i>H.243</i>	ITU-T standard that defines initiation of communications between systems and capabilities negotiation procedures in multipoint conferences.
<i>H.261</i>	ITU-T standard that defines the Px64 video coding algorithm.
<i>H.263</i>	ITU-T standard that provides improved compression and quality of video images at a line rate lower than 384Kbps. This standard is not supported by all codecs.
<i>H.264</i>	ITU-T standard that provides improved compression and quality of video images in lower line rate connections and is part of the Highest Common mechanism in Video Switching conferences.
<i>H.323</i>	ITU-T standard for audio, video and data communications across IP-based (LAN) networks, including the Internet.
<i>IP</i>	Internet Protocol. The working protocol that forms the basis of the internet.
<i>ITU-T Standard</i>	International Telecommunications Union, Telecommunication Standardization Sector (formerly CCITT). An international group that produces official standards for

Abbreviation/Term	Explanation
	telecommunications.
<i>LAN</i>	Local Area Network. A group of computers and other devices linked via a network's operating system.
<i>Line Rate</i>	The amount of bandwidth used by a communication device, measured in Kbps (kilobits per second).
<i>MCU</i>	Multipoint Control Unit. Device which allows more than two sites to be connected in a video conference.
<i>PCM</i>	Personal Conference Manager, a user interface displayed on the endpoint's video output screen. The user interacts with the PCM through the DTMF command and FECC function by using the endpoint remote control, to implement conference control at the MCU. For example, create a conference, dial into a conference, set the window layout, remotely control the camera, and terminate a conference.
<i>Participant</i>	A person using an endpoint to connect to a conference.
<i>QCIF</i>	Quarter CIF. A video format with image size of 176x144 pixels that transmits 30 frames at 9.115Mbps per second (a quarter of the capacity of CIF). For more information, see CIF.
<i>QoS</i>	Quality of Service. QoS defines the performance of a network service, such as the average delay between packets.
<i>ToS</i>	Type of Service. It defines optimization tagging for routing audio and video packets.
<i>WAN</i>	Wide Area Network. A communications network that services a geographical area larger than the LAN.
<i>High Definition (HD)</i>	High Definition (HD) refers to ultra-high quality video resolutions. An HD-compliant endpoint can connect to a conference at a resolution of 1280x720 (720p) and a bit rate of 384kbp~ 4Mb. When setting up an HD video conference, all participants connected to the conference are required to use the same conference bit rate and same HD settings. Those endpoints unable to meet the above requirements will be treated as secondary connections (audio only).



# Third Party Software Licenses

This appendix provides the copyright statements for third party software products that are part of the Polycom RMX 1000.

**Table 20-1** Third Party Licenses

Software Source Name	License Type	License URL
Busybox 1.7.1	GPL V3.0	<a href="http://www.gnu.org/copyleft/gpl.html">www.gnu.org/copyleft/gpl.html</a>
Grub 0.97	GPL V3.0	<a href="http://www.gnu.org/copyleft/gpl.html">www.gnu.org/copyleft/gpl.html</a>
Linux kernel 2.6.24 rc7	GPL V3.0	<a href="http://www.gnu.org/copyleft/gpl.html">www.gnu.org/copyleft/gpl.html</a>
Glibc 2.6	GPL V3.0	<a href="http://www.gnu.org/copyleft/gpl.html">www.gnu.org/copyleft/gpl.html</a>
Openssl 0.9.8b	BSD-style	<a href="http://www.openssl.org/source/license.html">www.openssl.org/source/license.html</a>
Openssl ver 0.9.8b	OpenSSL	<a href="http://www.openssl.org/source/license.html">www.openssl.org/source/license.html</a>
Net-snmp ver 5.4	Net-SNMP	<a href="http://www.net-snmp.org/about/license.html">http://www.net-snmp.org/about/license.html</a>
Apache ver 2.2.4	Apache License v2.0	<a href="http://www.apache.org/licenses/LICENSE-2.0">http://www.apache.org/licenses/LICENSE-2.0</a>
Linux Kernel 2.6, modified,	GPLv2,	<a href="http://www.gnu.org/licenses/old-licenses/gpl-2.0.html">http://www.gnu.org/licenses/old-licenses/gpl-2.0.html</a>
GLIBC, binary, unmodified	LGPLv2.1	<a href="http://www.gnu.org/licenses/old-licenses/lgpl-2.1.html">http://www.gnu.org/licenses/old-licenses/lgpl-2.1.html</a>
open-ssl-0.9.8d	OpenSSL	<a href="http://www.openssl.org/source/license.html">www.openssl.org/source/license.html</a>
Apache,	Apache License v2.0	<a href="http://www.apache.org/licenses/LICENSE-2.0">http://www.apache.org/licenses/LICENSE-2.0</a>
Busybox, modified standalone app,	GPLv2	<a href="http://www.gnu.org/licenses/old-licenses/gpl-2.0.html">http://www.gnu.org/licenses/old-licenses/gpl-2.0.html</a>
Grub, modified standalone app	GPLv2	<a href="http://www.gnu.org/licenses/old-licenses/gpl-2.0.html">http://www.gnu.org/licenses/old-licenses/gpl-2.0.html</a>

Software Source Name	License Type	License URL
Libpcap	libpcap	<a href="http://sourceforge.net/projects/libpcap/">http://sourceforge.net/projects/libpcap/</a>
OpenLDAP	OpenLDAP Public License v 2.8 (17 August 2003)	<a href="http://www.openldap.org/software/release/license.html">http://www.openldap.org/software/release/license.html</a>
Net-SNMP	Net-SNMP	<a href="http://www.net-snmp.org/about/license.html">http://www.net-snmp.org/about/license.html</a>
Libpng	libpng License	<a href="http://www.opensource.org/licenses/zlib-license.php">http://www.opensource.org/licenses/zlib-license.php</a>
Jpeg.v6b	-	<a href="http://www.ijg.org/files/">http://www.ijg.org/files/</a>
bmp2png-1.62	-	<a href="http://pmt.sourceforge.net/bmp2png/index.html">http://pmt.sourceforge.net/bmp2png/index.html</a>
srtplib 1.4.2	BSD-based	<a href="http://srtplib.sourceforge.net/license.html">http://srtplib.sourceforge.net/license.html</a>
Libsrtplib 1.4.2	BSD-style	<a href="http://srtplib.sourceforge.net/license.html">http://srtplib.sourceforge.net/license.html</a>
reSiprocate 1.3	-	-



Modified open source code that is under GPL licenses is available upon request from Polycom Support.

## Free Manuals Download Website

<http://myh66.com>

<http://usermanuals.us>

<http://www.somanuals.com>

<http://www.4manuals.cc>

<http://www.manual-lib.com>

<http://www.404manual.com>

<http://www.luxmanual.com>

<http://aubethermostatmanual.com>

Golf course search by state

<http://golfingnear.com>

Email search by domain

<http://emailbydomain.com>

Auto manuals search

<http://auto.somanuals.com>

TV manuals search

<http://tv.somanuals.com>