

555-7101-217

CallPilot

Installation and Configuration

Part 2: 1001rp Server Hardware Installation

Product release 2.02

Standard 1.0

May 2003

NORTEL
NETWORKS™

P0605618

CallPilot

Installation and Configuration

Part 2: 1001rp Server Hardware Installation

Publication number:	555-7101-217
Product release:	2.02
Document release:	Standard 1.0
Date:	May 2003

Copyright © 2003 Nortel Networks, All Rights Reserved

Printed in Canada

Information is subject to change without notice. Nortel Networks reserves the right to make changes in design or components as progress in engineering and manufacturing may warrant.

The process of transmitting data and call messaging between the CallPilot server and the Meridian 1 switch or Succession CSE 1000 system is proprietary to Nortel Networks. Any other use of the data and the transmission process is a violation of the user license unless specifically authorized in writing by Nortel Networks prior to such use. Violations of the license by alternative usage of any portion of this process or the related hardware constitutes grounds for an immediate termination of the license and Nortel Networks reserves the right to seek all allowable remedies for such breach.

This page and the following page are considered the title page, and contain Nortel Networks and third-party trademarks.

*Nortel Networks, the Nortel Networks logo, the Globemark, and Unified Networks, BNR, CallPilot, DMS, DMS-100, DMS-250, DMS-MTX, DMS-SCP, DPN, Dualmode, Helmsman, IVR, MAP, Meridian, Meridian 1, Meridian Link, Meridian Mail, Norstar, SL-1, SL-100, Succession, Supernode, Symposium, Telesis, and Unity are trademarks of Nortel Networks.

3COM is a trademark of 3Com Corporation.

ACCENT is a trademark of Accent Software International Ltd.

AMDEK is a trademark of Amdek Corporation.

AT&T is a trademark of American Telephone and Telegraph Corporation.

ATLAS is a trademark of Quantum Corporation.

ATRIA is a trademark of Pure Atria Corporation.

BLACKBERRY is a trademark of Research in Motion Limited.

CASEWARE is a trademark of Caseware International, Inc.

CONTINUUS is a trademark of Continuus Software Corporation.

CRYSTAL REPORTS is a trademark of Seagate Software Inc.

DEFINITY is a trademark of Avaya Inc.

DIALOGIC is a trademark of Dialogic Corporation.

EUDORA is a trademark of Qualcomm.

EXCHANGE.NET, INTERNET EXPLORER, LINKEXCHANGE, MICROSOFT, MICROSOFT EXCHANGE SERVER, MS-DOS, OUTLOOK, POWERPOINT, WINDOWS, WINDOWS MEDIA, and WINDOWS NT are trademarks of Microsoft Corporation.

GROUPWISE and NOVELL are trademarks of Novell Inc.

HITACHI is a trademark of Hitachi Limited.

INTEL is a trademark of Intel Corporation.

LOGITECH is a trademark of Logitech, Inc.

NETSCAPE COMMUNICATOR is a trademark of Netscape Communications Corporation.

PCANYWHERE is a trademark of Symantec Corporation.

PROMARK and RHOBOT are trademarks of DMI Promark, Inc.

RADISYS is a trademark of Radisys Corporation.

SLR4, SLR5, and TANDBERG are trademarks of Tandberg Data ASA.

SYBASE is a trademark of Sybase, Inc.

UNIX is a trademark of X/Open Company Limited.

US ROBOTICS, the US ROBOTICS logo, and SPORTSTER are trademarks of US Robotics.

VOICEBRIDGE is a trademark of Voice Technologies Group Inc.

Publication history

May 2003

Release 2.02, Standard 1.0 of *CallPilot Installation and Configuration, Part 2: 1001rp Server Hardware Installation* is issued for general release. Information on single-point grounding has been added to Chapter 4, “Installing the server and connecting the peripheral devices”.

October 2002

Standard 1.0 of *CallPilot Installation and Configuration, Part 2: 1001rp Server Hardware Installation* is issued for general release.

Contents

1	1001rp server description	9
	Server features	10
	Slot assignments	14
	IRQ mapping table	17
	Network connectivity	19
	Supported peripheral devices	24
2	Preparing for installation	25
	Installation overview.	26
	Unpacking the 1001rp server	29
	Removing the front bezel and server cover	31
	Inspecting the server interior	35
3	Power supply installation	37
	Safety precautions.	38
	Section A: Installing the power supply modules (AC or DC)	39
	Installing the second power supply module (AC or DC)	40
	Section B: Setting up DC power source for a 1001rp DC server	43
	DC wire gauge tables	44
	DC rack cabling	46
	About the Power Distribution Unit.	48
	Bringing power and ground into the PDU	50

4	Installing the server and connecting the peripheral devices	53
	Installing the server	54
	Preparing the modem	55
	Connecting peripherals to the server	59
	Connecting the server to the ELAN	62
	Connecting the server to the CLAN (optional).	64
	Installing the Nortel Networks software feature key adapter	66
	Connecting the server to power	68
	Index	75

Chapter 1

1001rp server description

In this chapter

Server features	10
Slot assignments	14
IRQ mapping table	17
Network connectivity	19
Supported peripheral devices	24

Server features

Introduction

This section provides a general overview of the 1001rp server.

Server dimensions and weight

Height	32 cm (12.5 in.)
Width	48.3 cm (19 in.)
Depth (distance from front to back)	
■ without front bezel	49.5 cm (19.5 in.)
■ with front bezel	53.3 cm (21 in.)
Weight of fully loaded system	45.5 kg (100 lbs)

Front panel features (front view without the front bezel)

The front view of the 1001rp server chassis shows redundant dual fans to the left and the right of the status panel. The left drive bay holds six SCSI hard drives with hot-pluggable carriers. The media drive bay, located to the right, houses the CD-ROM, tape drive, and floppy disk drive.

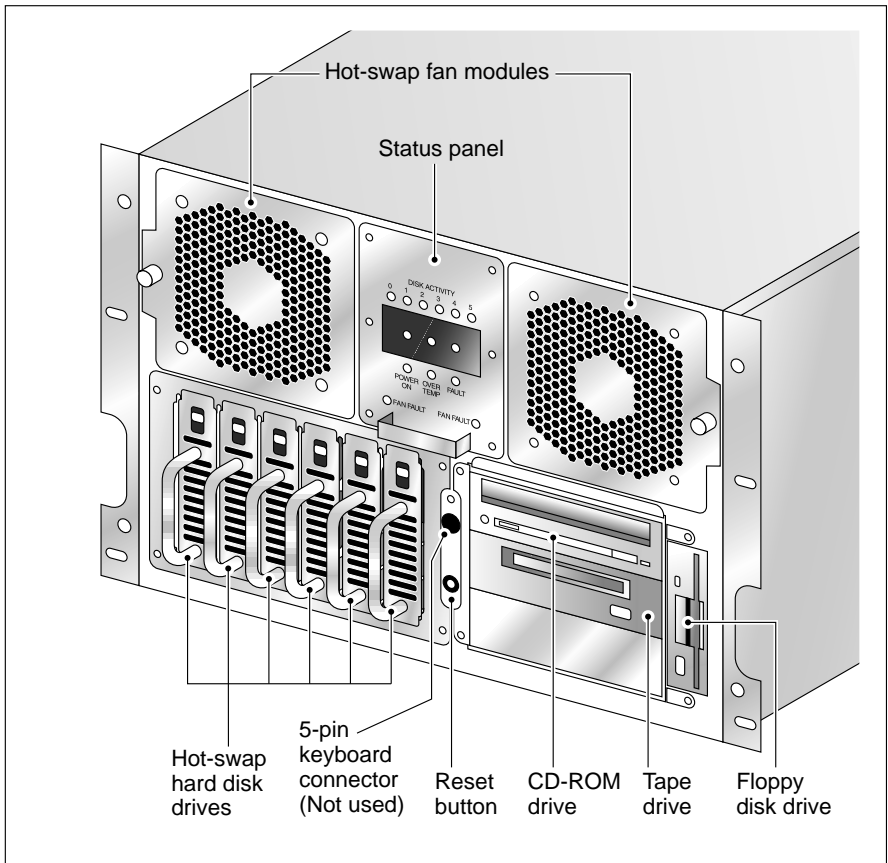

Alarm board

The alarm board is located under the baseboard. It connects to the status display panel on the front.

Rear panel diagram

Note: The following diagram shows the slot locations in the rear panel:

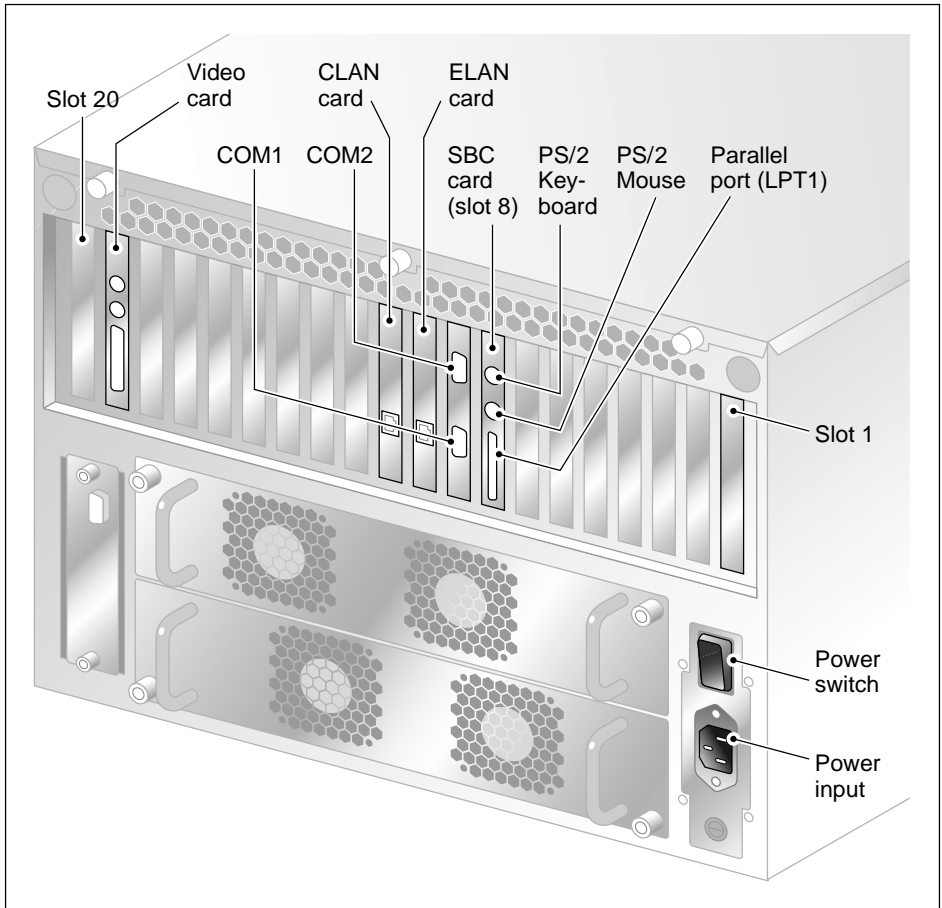

G101720

The above diagram shows the power switch and power input for an AC server. The rest of the diagram is the same for AC or DC servers.

Overhead view of empty server showing PCI and ISA connectors

The following diagram shows the location of the PCI, SBC, and ISA connectors inside the server. The view in the diagram is from the rear of the server. For slot assignments, see “Slot assignments” on page 14. You must be able to identify slot locations for later steps in the CallPilot installation.

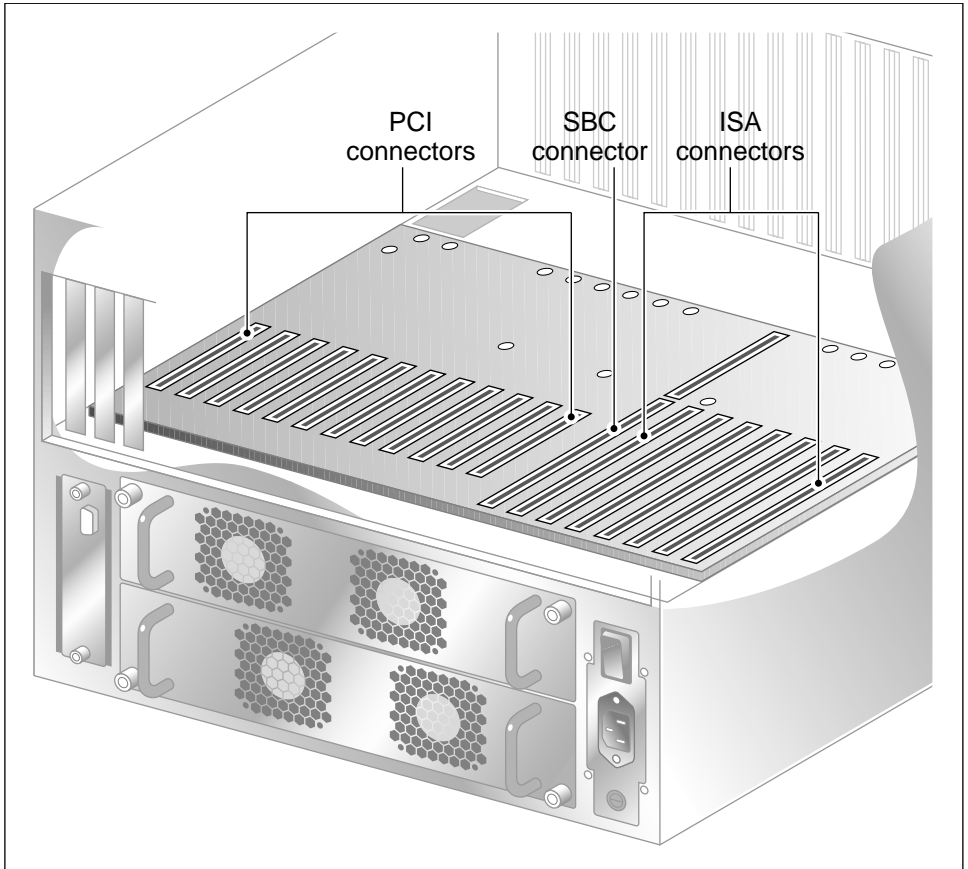

G101740

Slot assignments

Introduction

The slot assignment tables show the following:

- the physical location of boards inside the server, relative to other boards
- the order in which boards are installed (for example, board #1, 2, 3, and so on)
- how the boards are represented in some CallPilot Manager applications (such as the Maintenance Administration page)
- the maximum capacity for each switch connectivity

Note: Your server may vary depending on what was ordered from Nortel Networks. Therefore, your server may not have all of the slots populated.

Slot definition and slot numbering

In these tables, the term “slot” refers to the available slot openings in the chassis, not the PCI or ISA connectors inside the server.

Look at the server from the rear (see “Rear panel diagram” on page 12). The slots are numbered from right to left, 1 to 20. Now, look at the server from the front. The slots are numbered from left to right.

1001rp slot assignments

Slot number	CallPilot- assigned board label ^a	Meridian 1	Succession CSE 1000
Slot 1	BRD01	Not used	Not used
Slot 2	BRD02	Not used	Not used

Slot number	CallPilot- assigned board label^a	Meridian 1	Succession CSE 1000
Slot 3	BRD03	Not used	Not used
Slot 4	BRD04	Not used	Not used
Slot 5	BRD05	Not used	Not used
Slot 6	BRD06	Not used	Not used
Slot 7	BRD07	Not used	Not used
Slot 8	BRD08	Single Board Computer	Single Board Computer
Slot 9	BRD09	Reserved for COM1 and COM2 I/O bracket	Reserved for COM1 and COM2 I/O bracket
Slot 10	BRD10	ELAN Network card	ELAN Network card
Slot 11	BRD11	CLAN Network card	CLAN Network card
Slot 12 ^b	BRD12	MPB16-4 board #1	MPB16-4 board #1
Slot 13	BRD13	MPB16-4 board #2 (optional)	MPB16-4 board #2 (optional)
Slot 14	BRD14	Not used	Not used
Slot 15	BRD15	Not used	Not used
Slot 16	BRD16	Not used	Not used
Slot 17	BRD17	Not used	Not used
Slot 18	BRD18	Not used	Not used
Slot 19	BRD19	VGA card (monitor connection)	VGA card (monitor connection)

Slot number	CallPilot- assigned board label ^a	CallPilot- assigned board	
		Meridian 1	Succession CSE 1000
Slot 20	BRD20	PCI RAID controller	PCI RAID controller

a. On some CallPilot Manager applications, the CallPilot-assigned board label appears. This label corresponds to the slot number. For example, BRD12 refers to the board in slot 12.

b. For Meridian 1 and Succession CSE 1000, the first MPB16-4 board must be installed in slot 12.

IRQ mapping table

Introduction

The following table displays the assignments for each Interrupt Request Line (IRQ) with the associated slot or device. You do not need this information for installation, but you may need it for troubleshooting.

Note: IRQs 9, 10, 11, and 15 are assigned to system PCI slots rather than to specific devices.

IRQ	Slot or device
0	Timer
1	Keyboard
2	System / Unused
3	Serial port 2 (COM2)
4	Serial port 1 (COM1)
5	Available
6	Floppy controller
7	Parallel port (LPT1)
8	Real Time Clock
9	Assigned to slots 9, 15, and 20
10	Assigned to slots 10, 13, and 19
11	Assigned to slots 11, 14, and 17
12	PS/2 mouse

IRQ	Slot or device
13	Math coprocessor
14	Primary EIDE controller
15	Assigned to slots 12, 16, and 18

Network connectivity

Introduction

This section describes how the 1001rp server can be integrated into your network. The integration depends on the type of switch you are using.

ATTENTION

To secure the CallPilot server from unauthorized access, ensure that the CallPilot network is inside your organization's firewall.

Note: The diagrams show a tower server. However, the same configuration applies to the 1001rp server.

Sample network setup: Meridian 1

The following diagram shows a CallPilot server sample network setup with a Meridian 1 switch. The Meridian 1 switch can be one of the following:

- Option 11C or Option 11C Mini
- Option 51C
- Option 61C
- Options 81 and 81C

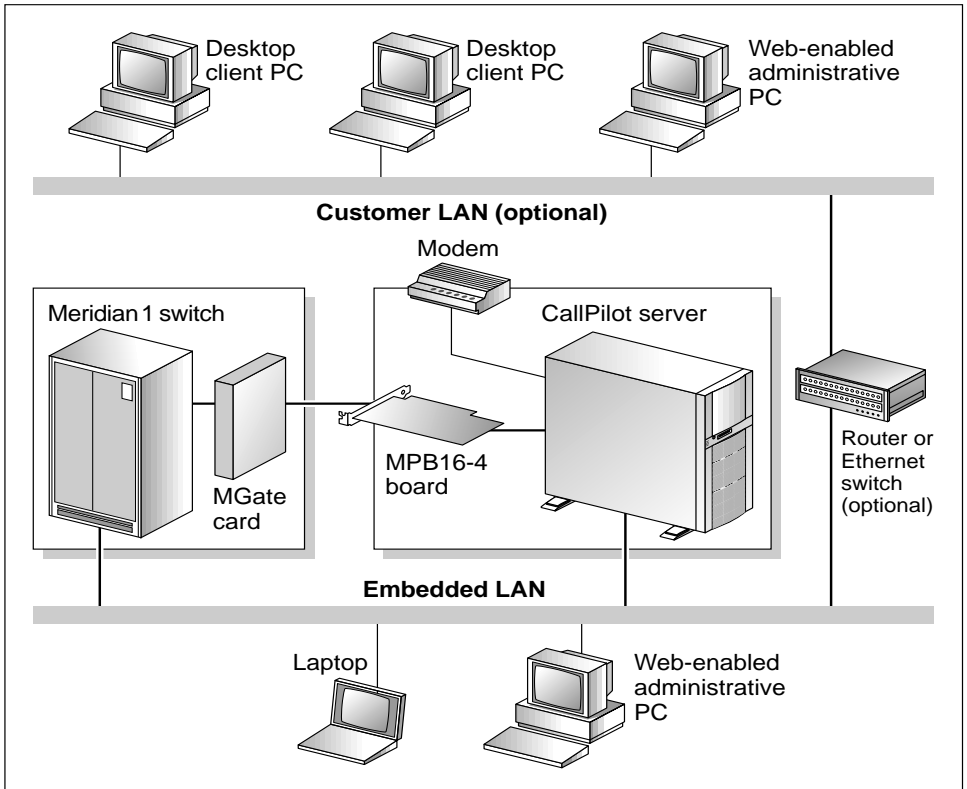

G101626

Sample network setup: Succession CSE 1000

The following diagram shows a CallPilot server network setup with a Succession CSE 1000 system:

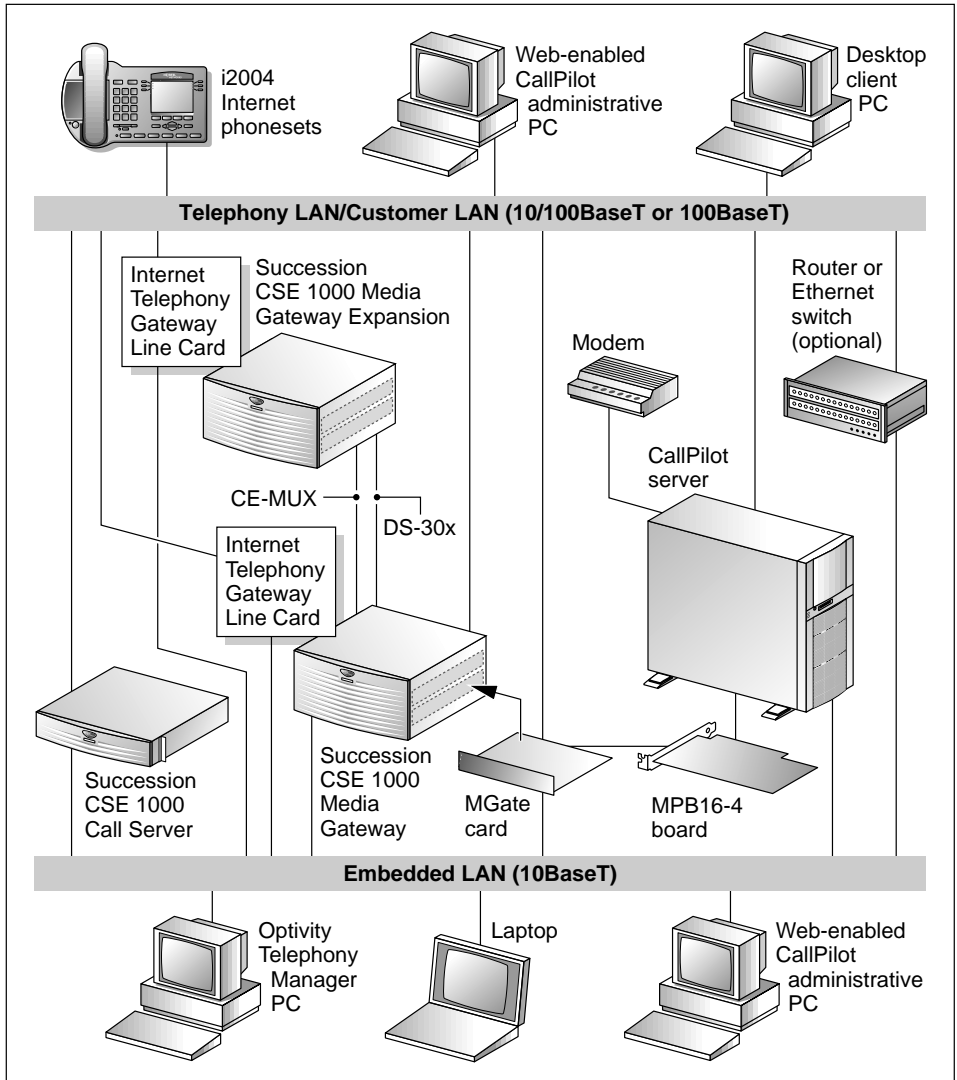

G101636

In this illustration, the telephony LAN (TLAN) provides IP connectivity between the Succession CSE 1000 system and the i2004 Internet phonesets. The connection between the Call Server and Media Gateway can be point-to-point, or it can be through the LAN, if the system is installed in a distributed data network.

For information about the Succession CSE 1000 system and i2004 Internet phoneset bandwidth and network requirements, refer to the *Succession Communication Server for Enterprise 1000 Planning and Installation Guide* (NTP 553-3023-210).

Switch connectivity

For more details about how the 1001rp server and switch connection is established, refer to Part 3 of the *CallPilot Installation and Configuration* binder.

CallPilot ELAN and CLAN network setup

The 1001rp server provides 10- or 100Base-T Ethernet connectivity through network interface cards (NIC) installed in the server. See “Slot assignments” on page 14 for details on the location of network cards. The function of each network card is described below:

- One network card provides connectivity to the ELAN.

For information about the ELAN’s purpose and requirements, see “About the ELAN” in Part 1 of the *CallPilot Installation and Configuration* binder.

- A second network card is optional.

This optional NIC is required only for Meridian 1 or Succession CSE 1000 systems that require a CLAN connection (in addition to the ELAN connection). The CLAN provides data connectivity between desktop and web messaging clients, web-enabled administrative PCs, and the CallPilot server.

Network requirements

Appropriate networking equipment must be available for both the CLAN and ELAN.

The CLAN and ELAN must be properly configured for correct CallPilot operation. To ensure correct configuration, Nortel Networks recommends that you consult a network specialist.

ATTENTION

For important considerations about using the ELAN in your network, see “About the ELAN” in Part 1 of the *CallPilot Installation and Configuration* binder.

Remote access connectivity

The RS-232 COM 1 connector on the rear of the 1001rp server provides the connection to an external modem. The modem allows administrators and technical support personnel to administer the 1001rp server from a remote location.

pcAnywhere is used to establish the remote access connection to the server.

Supported peripheral devices

Introduction

This section identifies external devices that are supported by the 1001rp server. The following table describes the supported peripheral devices:

Device	Description
Modem	<p>A 56 Kbps external modem (NTRH9078) provides remote access to the 1001rp server. The modem connects to the RS-232 COM1 connector on the rear of the server.</p> <p>Since the modem is an external device, it requires its own AC power source. The 33.6 Kbps modem (NTRH9016) is also supported, but has been replaced by the 56 Kbps modem for new systems.</p>
Ethernet hub	<p>A 10BaseT Ethernet hub provides the ELAN connection between the 1001rp server and the Meridian 1 switch or Succession CSE 1000 system. The customer can supply a hub from third-party vendors or purchase the 3Com 10BaseT Ethernet hub (NTRH9017) from Nortel Networks.</p> <p>Since the hub is an external device, it requires an AC power source.</p>
Monitor, keyboard, and mouse	<ul style="list-style-type: none"> <li data-bbox="381 1102 703 1129">■ 14" monitor: NTRH9011 <p data-bbox="409 1145 1037 1204">Since the monitor is an external device, it requires its own AC power source.</p> <ul style="list-style-type: none"> <li data-bbox="381 1225 680 1252">■ Keyboard: NTRH9013 <li data-bbox="381 1273 645 1299">■ Mouse: NTRH9014

Chapter 2

Preparing for installation

In this chapter

Installation overview	26
Unpacking the 1001rp server	29
Removing the front bezel and server cover	31
Inspecting the server interior	35

Installation overview

Introduction

This section provides an overview of the steps required to install the 1001rp server and peripheral devices.

Installation checklist

The following checklist identifies the tasks that must be performed when installing the CallPilot server. For detailed instructions, see Chapter 4, “Installing the server and connecting the peripheral devices.”

When you are finished, continue with Part 3 of the *CallPilot Installation and Configuration* binder.

Step	Description	Check
1	Ensure that you have reviewed the “Installing CallPilot” section in Part 1 of the <i>CallPilot Installation and Configuration</i> binder, and completed stage 1 of the “Installation checklist.”	<input type="checkbox"/>
2	Unpack the server, and ensure you have all the items you need (see page 29). Complete the following checklists that are provided in Part 1 of the <i>CallPilot Installation and Configuration</i> binder: <ul style="list-style-type: none"> ■ “CallPilot software media and documentation checklist” ■ “CallPilot server hardware checklist” 	<input type="checkbox"/>
3	Remove the front bezel and server cover, and inspect the interior (see pages 31 and 35).	<input type="checkbox"/>
4	Replace the server cover.	<input type="checkbox"/>
5	Install the power supply modules in the server (see page 40).	<input type="checkbox"/>

Step	Description	Check
6	For a DC-powered server, set up the DC power source (see page 43).	<input type="checkbox"/>
7	Place the 1001rp server in the chosen location (see page 54).	<input type="checkbox"/>
8	Replace the front bezel (see page 34).	<input type="checkbox"/>
9	Set the DIP switches on the modem (see page 57).	<input type="checkbox"/>
10	Connect the 1001rp server and devices as follows: <ul style="list-style-type: none"><li data-bbox="199 558 904 584">■ Connect the monitor, keyboard, and mouse (see page 59).<li data-bbox="199 616 631 641">■ Connect the modem (see page 60).<li data-bbox="199 673 929 737">■ Connect the 1001rp server to the ELAN hub (Meridian 1 or Succession CSE 1000 only) (see page 62).<li data-bbox="199 769 929 833">■ Connect the 1001rp server to the CLAN hub (optional) (see page 64).<li data-bbox="199 865 855 890">■ Install the software feature key adapter (see page 66).<li data-bbox="199 922 891 986">■ Connect the power cords for all devices, and then power them up.	<input type="checkbox"/> <input type="checkbox"/> <input type="checkbox"/> <input type="checkbox"/> <input type="checkbox"/> <input type="checkbox"/>
11	Start the 1001rp server (see page 68).	<input type="checkbox"/>

Conventions for warnings

You may encounter the following types of warnings in this guide. Do not ignore them.



DANGER

Risk of electric shock

Warns you of an immediate electrical hazard which, if not avoided, will result in shock, serious injury, or death.



WARNING

Risk of personal injury

Warns you of a situation in which you can be injured if instructions are not followed exactly as stated.



CAUTION

Risk of equipment damage

Alerts you to situations where data can be lost or damaged, equipment can be damaged, actions can result in service interruption, and productive time can be lost.

ATTENTION

Provides information that is essential to the completion of a task.

Unpacking the 1001rp server

Introduction

Follow this procedure to unpack the server and peripherals.



WARNING

Risk of personal injury

The 1001rp CallPilot server weighs approximately 34 kg (75 lbs) as shipped from manufacturing. To prevent personal injury, have someone help you to unpack and position the server.

To unpack the equipment

ATTENTION

As you unpack each item, check it off against the packing list, as well as against the following checklists provided in Part 1 of the *CallPilot Installation and Configuration* binder:

- “CallPilot software media and documentation checklist”
- “CallPilot server hardware checklist”

- 1 Carefully open the cardboard carton containing the server.
- 2 Remove the server from the carton and set it on the floor.
- 3 Carefully open the cartons containing the monitor, keyboard, mouse, modem, and ELAN hub (if supplied), and set the peripherals aside.
- 4 Put all manuals, CD-ROMs, operating system disks, any disks for peripherals, and the Windows NT emergency repair disk in a safe place.

- 5 Save all packing materials and cartons in case you must return any equipment to the carrier.

What's next?

Remove the server cover so that you can inspect the interior of the server. See “Removing the front bezel and server cover” on page 31.

Removing the front bezel and server cover

Introduction

To access the server interior, you must remove both the front bezel and the server cover.

To remove the front bezel, see page 32.

To remove the server cover, see page 33.

To replace the front bezel, see page 34.

About the front bezel doors

Two locked doors on the front of the server cover the front panel, including the CD-ROM drive and tape drive.

These doors are part of the front bezel, which covers the front of the server. You must unlock the front bezel doors before you can remove the front bezel.

To remove the front bezel



CAUTION

Risk of equipment damage

Do not attempt to move or lift the server before removing the front bezel; the server can disengage from the bezel and fall.

- 1 Unlock and open the double doors of the front bezel. See “A” in the diagram below.
- 2 Firmly grasp the front bezel by the hand-holds on either side of the chassis, and pull the front bezel from the chassis.

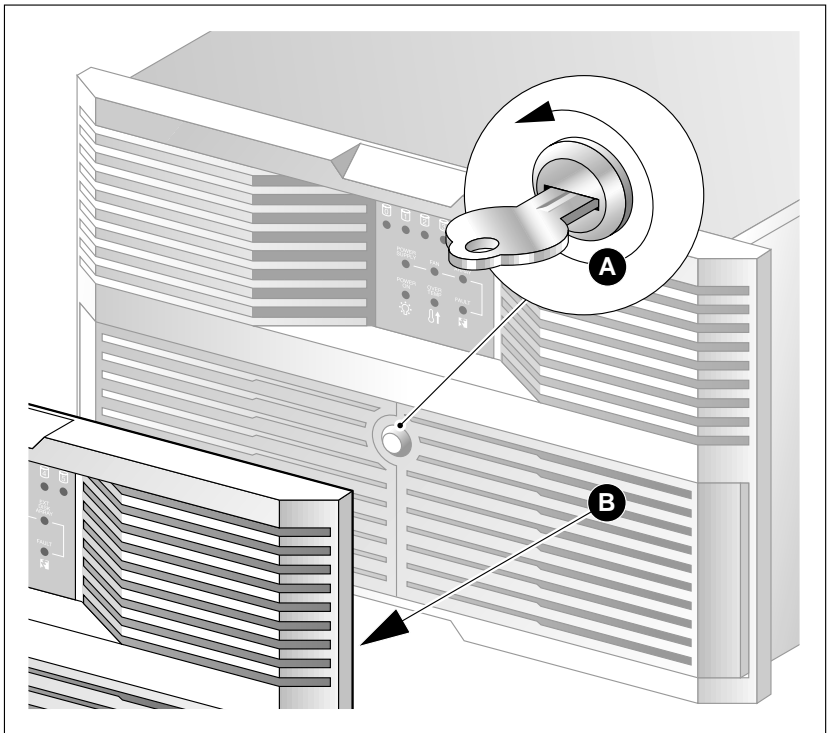

G101733

To remove the server cover



DANGER

Risk of electric shock

High current inside the chassis can cause severe injury.



CAUTION

Risk of equipment damage

Take precautions to protect internal components. Electrostatic discharge (ESD) can render boards damaged or unusable. Wear an ESD wrist strap.

- 1 Remove the front bezel (see page 32).
- 2 Loosen the three thumbscrews at the rear of the top cover.
- 3 Remove the server cover by pulling the cover toward the rear of the chassis, and then lifting it up and off.
- 4 Clip the lead from your ESD wrist strap to an unpainted metal section of the chassis.

What's next?

Continue with “Inspecting the server interior” on page 35.

To replace the front bezel after installation is complete

When the CallPilot server installation is complete and the server is in its final location, replace the front bezel.

- 1 Align the front bezel with the ball studs located at each faceplate corner.

See the diagram below:

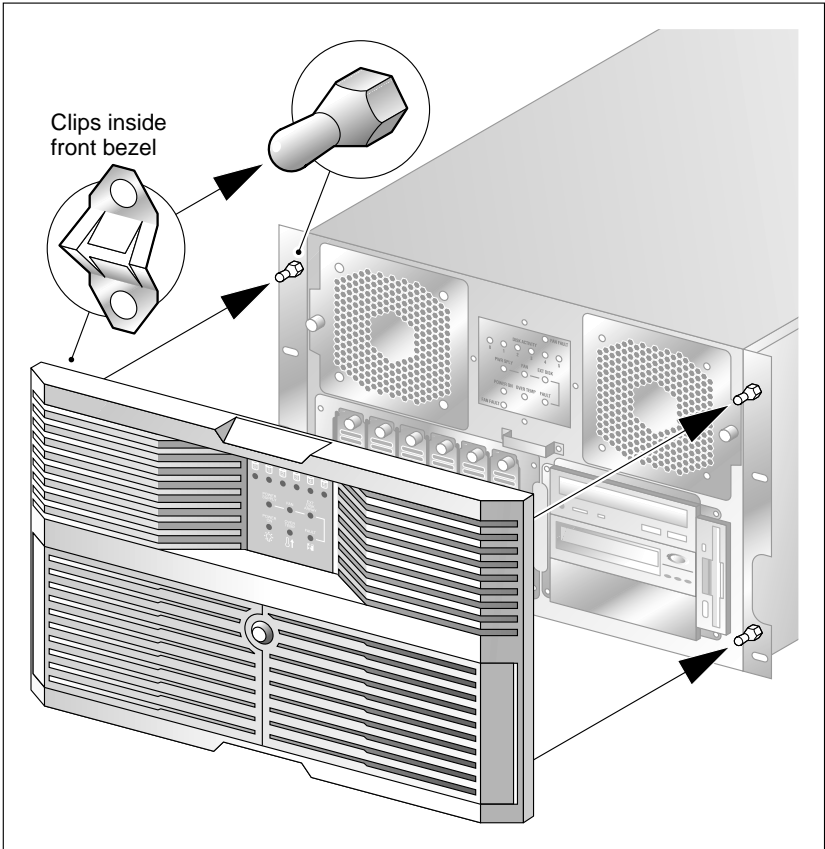

G101734

- 2 Apply pressure evenly until the bezel snaps onto each ball stud.
- 3 Close and lock the double doors of the front bezel.

Inspecting the server interior

Introduction

You should perform a visual inspection for loose components, foreign matter, or shipping damage inside the server.



CAUTION

Risk of equipment damage

When working with interior components, use an ESD wrist strap to protect static-sensitive components.

To inspect the server interior

- 1 Carefully check all the cards to ensure they are fully seated on the baseboard.
- 2 Check for any loose wires or foreign objects, such as loose screws, inside the chassis.
- 3 Review the slot locations (see “Slot definition and slot numbering” on page 14).
- 4 Do one of the following:

IF	THEN
you observe any damage	contact your Nortel Networks technical support representative.
components have become loose	secure them. Refer to the procedures in Part 5 of the <i>CallPilot Installation and Configuration</i> binder.

IF	THEN
you are satisfied that the 1001rp server has arrived at your site undamaged	replace the server cover and proceed with the hardware installation. See “Installation checklist” on page 26. Note: Do not reinstall the front bezel until the server is in its final location and the CallPilot installation is complete.

Chapter 3

Power supply installation

In this chapter

Safety precautions	38
Section A: Installing the power supply modules (AC or DC)	39
Installing the second power supply module (AC or DC)	40
Section B: Setting up DC power source for a 1001rp DC server	43
DC wire gauge tables	44
DC rack cabling	46
About the Power Distribution Unit	48
Bringing power and ground into the PDU	50

Safety precautions

Equipment handling guidelines

External power equipment, such as an uninterruptible power supply (UPS), is usually very heavy. This equipment requires special handling procedures and additional personnel for unloading and installation. Be aware of weight distribution, and prevent the equipment room floor from being overly stressed.

Safety information

In DC systems, locate the service panel near the entry to the room containing the DC power system that supplies the server.



DANGER

Risk of electric shock

Procedures involving electrical connections must only be performed by qualified personnel.

Ensure that you obey all displayed warning notices on power equipment and connections.

Section A: Installing the power supply modules (AC or DC)

In this section

Installing the second power supply module (AC or DC)

40

Installing the second power supply module (AC or DC)

Introduction

One power supply module is shipped installed. The second power supply module is shipped uninstalled and must be installed as part of the CallPilot installation.

AC versus DC systems

The power supply modules are similar in appearance for both AC and DC 1001rp servers. The procedures in this section apply to both AC and DC 1001rp servers.

About the power supply module

After the server is powered up (later in this guide), the power supply module LED indicates its status.

A green LED indicates that the power supply module is working properly. If the LED on the power supply module is unlit or red, the module is failing or has failed. Other indicators are an alarm sounding and the power supply LED on the status display on the front of the server turning red.

The diagram below shows the location of the power supply modules in a server that has both power supply modules installed:

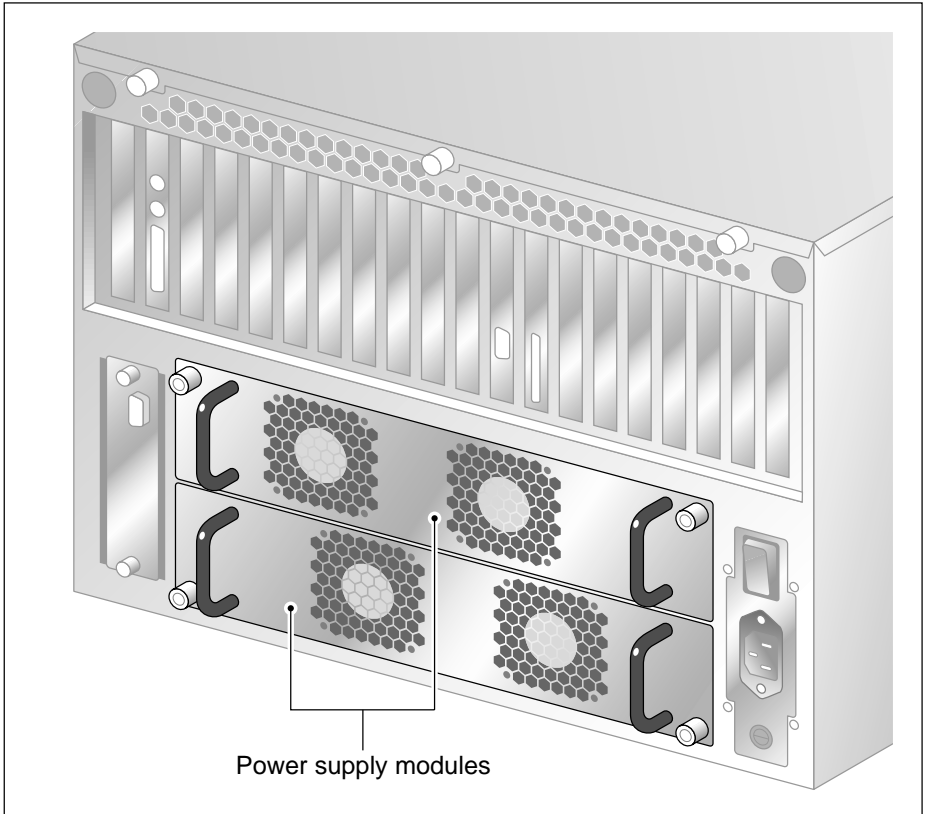

G101751

To install the power supply module



DANGER

Risk of electric shock

High current inside the chassis can cause severe injury.

The server is shipped with one power supply module installed in the bottom power supply bay. You must install the second power supply module, as described here:

- 1 Align the power supply module with the top power supply bay.
- 2 Slide the power supply module into the bay until the module is secured by its connector.
Use some force, if necessary.
- 3 Secure the power supply module to the chassis with two thumbscrews at the corners of the power supply faceplate.

What's next?

Do one of the following:

IF

THEN

this is an AC-powered server

continue with Chapter 4, "Installing the server and connecting the peripheral devices," on page 53.

this is a DC-powered server

continue with Section B: "Setting up DC power source for a 1001rp DC server," on page 43.

Section B: Setting up DC power source for a 1001rp DC server

In this section

DC wire gauge tables	44
DC rack cabling	46
About the Power Distribution Unit	48
Bringing power and ground into the PDU	50

DC wire gauge tables

Introduction

The tables in this section specify the DC power feed wire requirements.

Cabinet and module DC feed recommended wire gauge specifications

Length	#10 AWG	#8 AWG	#6 AWG	Junction box #4 AWG	Junction box #4 AWG
0–30 m (100 ft)	yes	yes	yes	yes	yes
0–45 m (150 ft)	no	yes	yes	yes	yes
0–75 m (250 ft)	no	no	yes	yes	yes
0–135 m (450 ft)	no	no	no	yes	yes
0–210 m (700 ft)	no	no	no	no	yes
Over 210 m (700 ft)	no	no	no	no	no

Notes:

1. Cabinet and module ground wire specification is #10 AWG insulated green safety ground wire.
2. Cabinet conduit can be 1.91 cm (0.75 in.) or 3.18 cm (1.25 in.), and must be insulated from cabinet ground.

Metric wire conversion

AWG No.	Industry standard nominal (sq mm)	Resistance at 20° C (Ohm/100 m)
2	35	0.05
4	25	0.08
6	16	0.13
8	10	0.20
10	6	0.33
12	4	0.63
14	2.5	1.00
16	1.5	1.40
18	1	2.00
20	0.75	2.90
22	0.5	4.60

DC rack cabling

The following diagram shows typical rack power cabling:

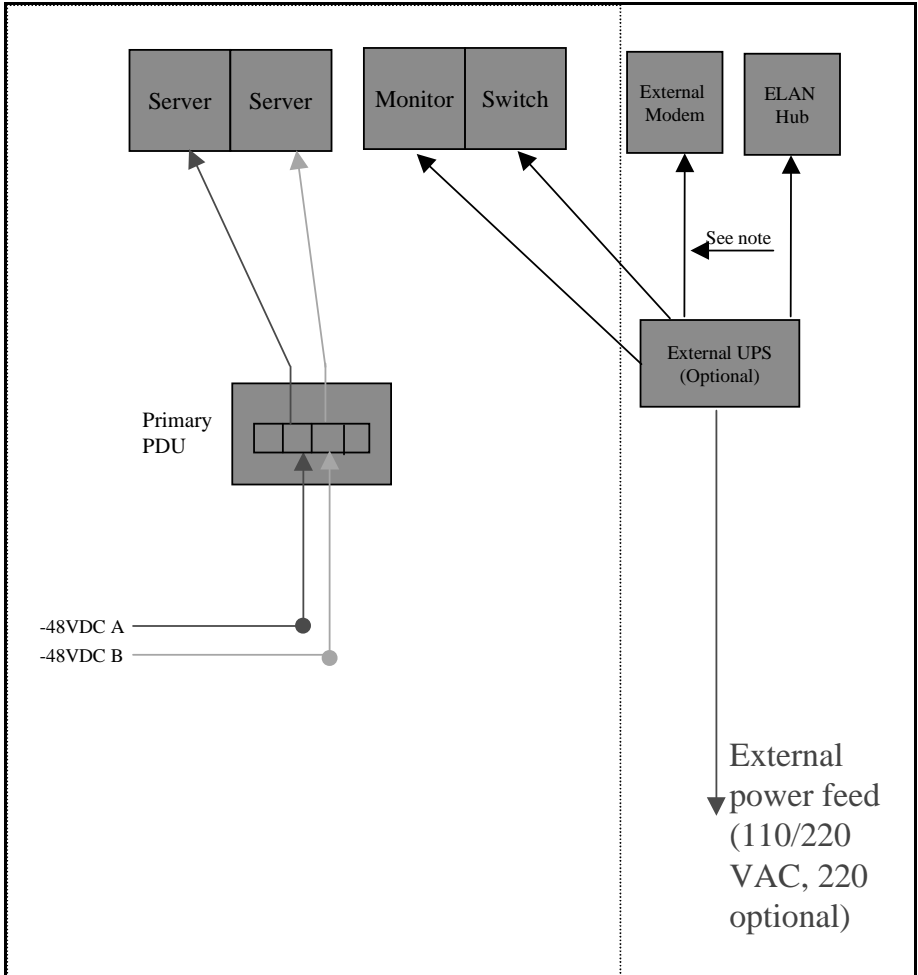

-48VDC power distribution rationale

- Minimum installation is one Power Distribution Unit (PDU) with four 48VDC branch circuits fused at 20 amperes.
- The customer must be able to shut off any branch, and every unit at the site will continue to function properly.
- DC-powered configuration fits into this scheme as follows:
 - Each PDU receives four branch circuits.
 - Each server receives a feed from each PDU and a different branch circuit.
- In this fashion, with dual hot-swappable power supplies, there is no single point of failure in the power system. For example, you can remove any power supply, including a PDU, and everything continues to work.
- This is applicable to either North American or European installation sites (with a 230 VAC Inverter).
- The secondary rack supports four servers and follows a similar scheme.

About the Power Distribution Unit

Introduction

A Power Distribution Unit (PDU) is installed in a rack that has DC-powered servers. Power from the DC supply source enters the PDU and can then be distributed to one or more servers. A single PDU can supply DC power to four DC power supply modules. A server can have either one or two power supply modules installed. You can determine the number of PDUs to install in a rack by counting the number of power supply modules in each rack.

Multiple PDUs

A server operates on a single power supply module. Its total capacity is two installed power supply modules. The second power supply module is the redundant power supply module.

A PDU can distribute power to a maximum of four power supply units that can be installed in two or more servers. Therefore, if there are three or four servers installed in a rack, then you must install a second PDU.

Note: The power supply module installs in the server. It does not refer to a UPS, which is a separate unit on the rack.

PDU terminal blocks and wiring diagram

A PDU consists of eight terminal blocks within a metal enclosure. Before installing the PDU, connect the terminal blocks so that each output connector receives power from a separate -48VDC branch circuit, as shown in the following diagram. Use AWG 12 wires for these connections.

Single PDU wiring diagram

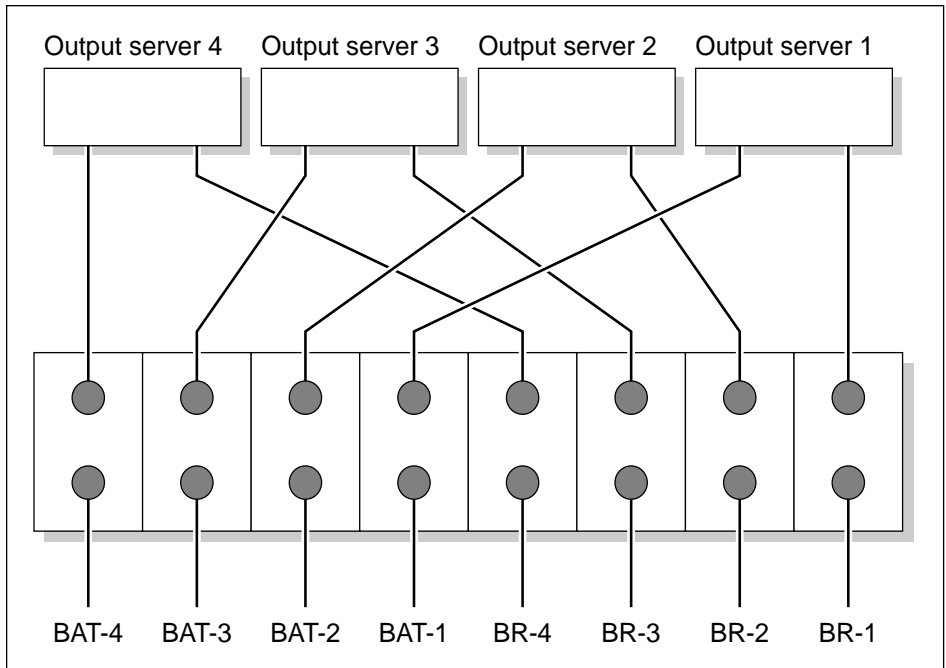

G101741

DC power input

DC power input into the distribution unit connects BAT-1 to BAT-4 and BR-1 to BR-4. Refer to the preceding diagrams for the location of these terminals. Connect the input wires before installing the PDU on the rack.

Bringing power and ground into the PDU

Introduction

Install BAT/BATRTRN wires in pairs. Each pair of wires supplies voltages to a module through a power harness. The module harnesses are installed in the cabinet PDU and connected to the modules at the factory.

See “About the Power Distribution Unit” on page 48 for a PDU wiring diagram and description.

To bring DC power and ground into the PDU

- 1 If you are using a conduit, terminate the 1-1/4 or 3/4 conduit at the top rear of the cabinet or at the bottom front of the cabinet using the knockouts provided.

The number of wire pairs you can run in each conduit depends on the wire gauge.

Note: To preserve ground integrity, the conduit must be insulated.

- 2 Select a power feed with a circuit breaker dedicated to each module, and identify it with an appropriate tag.
- 3 Select a wire size to suit the required feed length from the power source (see “DC wire gauge tables” on page 44).
- 4 Use pliers to strip one-quarter to one-half of the insulation from one end of all power and ground feed wires.
- 5 Undo the terminal block screws at (-) positions 0, 1, 2, and 3.
- 6 Insert the *red* wires into terminal block positions 0, 1, 2, and 3.
- 7 Secure the wires in the terminal block by tightening the screws.
- 8 Undo the terminal block screws at (+) positions 0, 1, 2, and 3.
- 9 Insert the *black* wires into terminal block positions 0, 1, 2, and 3.
- 10 Secure the wires in the terminal block by tightening the screws.

- 11** Select a #10 green wire safety ground and attach it to the cabinet.
- 12** Measure the module ground continuity by touching one multimeter lead to any BATRTN terminal block connector and the other end to the GND terminal block connector.

The measurement should be between 0–0.5 ohms.

Chapter 4

Installing the server and connecting the peripheral devices

In this chapter

Installing the server	54
Preparing the modem	55
Connecting peripherals to the server	59
Connecting the server to the ELAN	62
Connecting the server to the CLAN (optional)	64
Installing the Nortel Networks software feature key adapter	66
Connecting the server to power	68

Installing the server

Introduction

Before you install the 1001rp server, ensure that the chosen location meets the requirements identified on the “Site inspection checklist” provided in Part 1 of the *CallPilot Installation and Configuration* binder.

To install the server

Place the 1001rp server in its chosen location. If you are installing the server in a rack cabinet, follow the instructions that are provided with the slide rails.

Connect peripheral devices as described in the remainder of this chapter.

ATTENTION

Do not connect the server to power yet.

Preparing the modem

Introduction

You require a modem to support remote dial-up access to the CallPilot server. The modem also enables Nortel Networks technical support to connect to your CallPilot server for troubleshooting purposes. Nortel Networks connects to your server only when you request technical assistance.

Required equipment

To install the modem, you need the following equipment:

- an analog external modem that includes
 - an RJ-11 analog phone cord
 - a power adapter cord

One of the following modems may have been provided with your server:

- U.S. Robotics 33.6 Kbps modem (NTRH9016)
- U.S. Robotics 56 Kbps modem (NTRH9078)
- a 25-pin male to 9-pin female shielded serial cable for your modem

Note: Ensure that you have the correct cable for your modem, as follows:

- 33.6 Kbps modem: A0601464
- 56 Kbps modem: A0841984
- an analog line jack
- tweezers, or a screw driver small enough to use to adjust the DIP switches

Modem DIP switches

Set the modem DIP switches before you connect the modem to the CallPilot server.

Note: This section applies only to the US Robotics 33.6 or 56 Kbps external Sportster modem. If your modem is different, refer to the documentation for your modem.

The following diagram shows the key components of the external modem, including the location and required settings of the DIP switches:

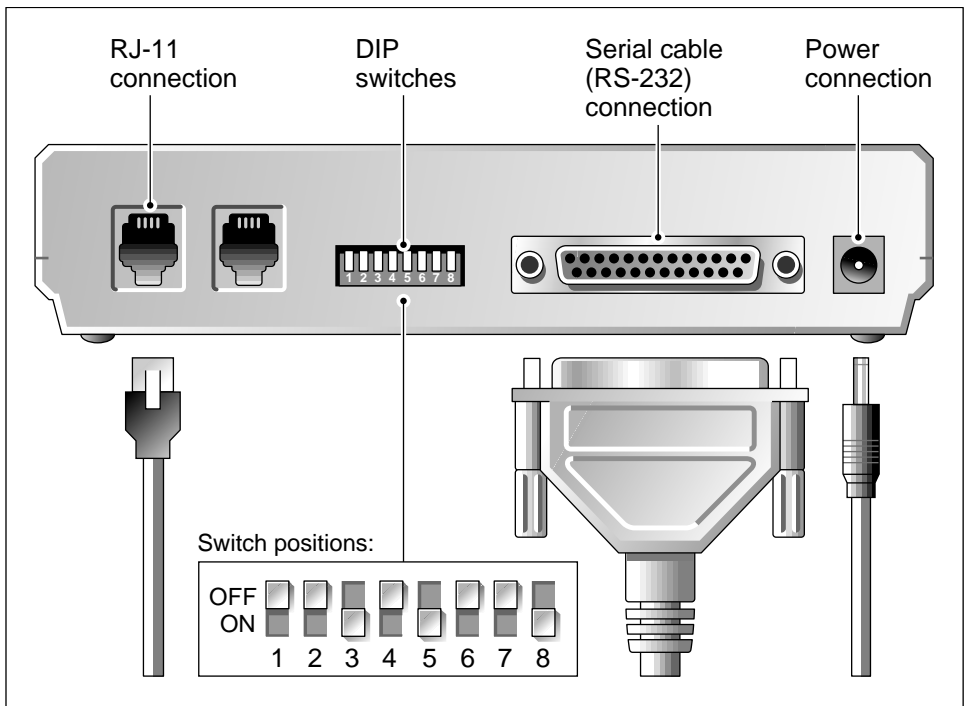

G101445

To set the modem DIP switches

Use a pair of tweezers or a small screw driver to set the DIP switches as described in the “Change to” column of the following table:

Note: ON is down. OFF is up.

DIP switch	Default setting	Change to	Function
1	OFF	OFF	Data Terminal Ready (DTR) override <ul style="list-style-type: none"> ■ OFF: Normal DTR operations. (The computer must provide a DTR signal for the modem to accept commands. If DTR is dropped, the call is terminated.) ■ ON: The modem ignores DTR (override).
2	OFF	OFF	Verbal/numeric result codes <ul style="list-style-type: none"> ■ OFF: Verbal (word) results. ■ ON: Numeric results.
3	ON	ON	Result code display <ul style="list-style-type: none"> ■ OFF: Suppresses result codes. ■ ON: Enables result codes.
4	OFF	OFF	Command mode local echo suppression <ul style="list-style-type: none"> ■ OFF: Displays keyboard commands. ■ ON: Suppresses echo.
5	ON	ON	Auto answer suppression <ul style="list-style-type: none"> ■ OFF: The modem answers on the first ring, or higher if specified in NVRAM. ■ ON: Disables auto answer.

DIP switch	Default setting	Change to	Function
6	OFF	OFF	Carrier Detect (CD) override <ul style="list-style-type: none"> ■ OFF: The modem sends a CD signal when it connects with another modem; it drops the CD on disconnect. ■ ON: CD is always ON (override).
7	OFF	OFF	Power-on and ATZ reset software defaults <ul style="list-style-type: none"> ■ OFF: Loads Y or Y1 configuration from user-defined non-volatile memory (NVRAM). ■ ON: Loads &F0-Generic template from read-only memory (ROM).
8	ON	ON	AT command set recognition <ul style="list-style-type: none"> ■ OFF: Disables command recognition (dumb mode). ■ ON: Enables recognition (smart mode).

What's next?

Continue with “Connecting peripherals to the server” on page 59.

Connecting peripherals to the server

Rear panel connections

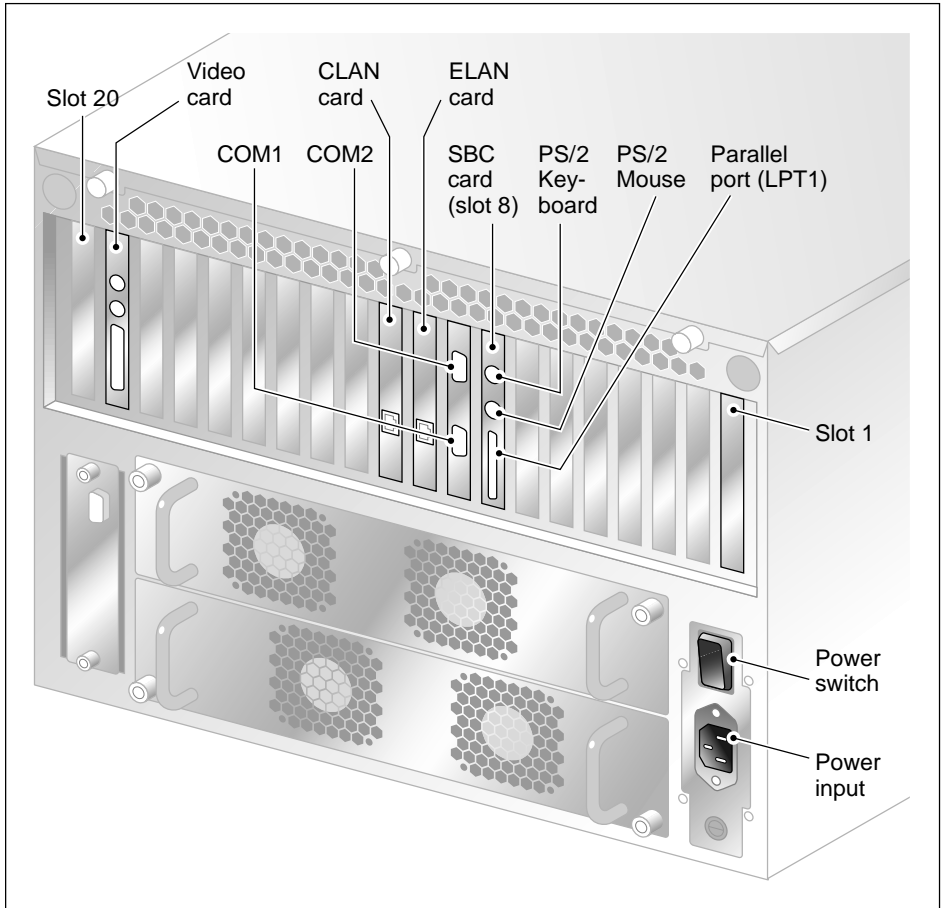

G101720

Note: The above picture shows the AC version of the server. The DC version of the server has a different power input. For peripheral device connections, this picture applies to both AC and DC servers.

**CAUTION****Risk of system failure**

You can install or use only Nortel Networks approved peripheral devices on your server. Installation or use of unapproved peripheral devices can result in system failure.

To connect the mouse, keyboard, and monitor to the server

- 1 Place the monitor, keyboard, and mouse in the same location as the server.
- 2 Plug the keyboard and mouse into the appropriate PS/2 connectors on the SBC. See the “Rear panel connections” on page 59.
- 3 Plug in the monitor to the video connector on the video card. Tighten the screws on the connector. See the “Rear panel connections” on page 59.
- 4 Connect the power cord to the monitor, and plug the other end into a wall receptacle or power bar.
- 5 Turn on the monitor.

To connect the modem to the server

- 1 Ensure that the modem’s AC power cord is not plugged in.
- 2 Connect the large 25-pin male connector to the back of the modem. Tighten the connector screws.
- 3 Connect the 9-pin female connector to COM1 at the rear of the server. Tighten the connector screws.
- 4 Connect one end of the telephone cable to the modem RJ-11 jack labeled LINE.
- 5 Connect the other end of the telephone cable to the RJ-11 jack in the wall.

- 6 Connect the power cord to the modem, and plug the other end into a wall receptacle or power bar.
- 7 Turn on the modem.

What's next?

Continue with “Connecting the server to the ELAN” on page 62.

Connecting the server to the ELAN

Introduction

Connect the CallPilot server to the Meridian 1 switch or Succession CSE 1000 system using the Embedded LAN (ELAN).

ATTENTION

For important considerations about using the ELAN in your network, see “About the ELAN” in Part 1 of the *CallPilot Installation and Configuration* binder.

Media Access Control address

The Media Access Control (MAC) address is a unique number assigned to network cards and controllers. The procedure below asks you to record the MAC address from the label affixed to the ELAN network card faceplate. The network card faceplate is visible through the slot openings in the back of the chassis.

To connect the server to the ELAN

- 1 Refer to the diagram on page 59 to locate the ELAN Ethernet connector.
- 2 Locate the label on the ELAN network card faceplate that identifies the ELAN controller's MAC address.
- 3 Record the MAC address on the Configuration Wizard worksheet that is provided in Part 1 of the *CallPilot Installation and Configuration* binder.

You need the MAC address to identify the ELAN when running the Configuration Wizard to configure the CallPilot server.

- 4 Connect an RJ-45 network cable from the ELAN hub to the ELAN connector on the server.

Note: The ELAN hub is optional if you use a cross-over network cable to make a direct point-to-point connection from the server to the switch.

However, if you choose to establish a direct point-to-point ELAN connection, no other device can connect to the ELAN.

- 5 At the switch, connect the ELAN network cable to an MAU (Ethernet) transceiver. Then complete the connection from the transceiver to the switch.



DANGER

Risk of fire hazard

MAU model NTRH9069 is not suitable for installation in ducts, plenums, or other spaces used for environmental air. Do not install it above a false ceiling or below a raised floor, unless it can be confirmed that these spaces are not used to convey environmental air.

What's next?

IF the server will	THEN
be connected to a CLAN	continue with page 64.
not be connected to a CLAN	continue with installing the software feature key adapter (dongle). See page 66.

Connecting the server to the CLAN (optional)

Introduction

This section provides instructions to connect the server to the Customer LAN (CLAN).

Note: The CLAN is optional. However, a CLAN is required to support desktop and web messaging users.

Media Access Control address

The Media Access Control (MAC) address is a unique number assigned to network cards and controllers. The procedure below asks you to record the MAC address from the label affixed to the CLAN network card faceplate. The network card faceplate is visible through the slot openings in the back of the chassis.

To connect the server to the CLAN

- 1 Refer to the diagram on page 59 to locate the CLAN network card.
- 2 Locate the label on the CLAN network card faceplate that identifies the CLAN controller's MAC address.
- 3 Record the MAC address on the Configuration Wizard worksheet that is provided in Part 1 of the *CallPilot Installation and Configuration* binder.
You need the MAC address to identify the CLAN when running the Configuration Wizard to configure the CallPilot server.
- 4 Connect an RJ-45 network cable from the CLAN hub to the CLAN connector.

What's next?

Continue with “Installing the Nortel Networks software feature key adapter” on page 66.

Installing the Nortel Networks software feature key adapter

Introduction

The software feature key is a security device that stores the unique serial number of the server. The feature key is embedded in the Nortel Networks software feature key adapter, which plugs into the parallel port.

An illustration of the software feature key embedded in the software feature key adapter is shown below:

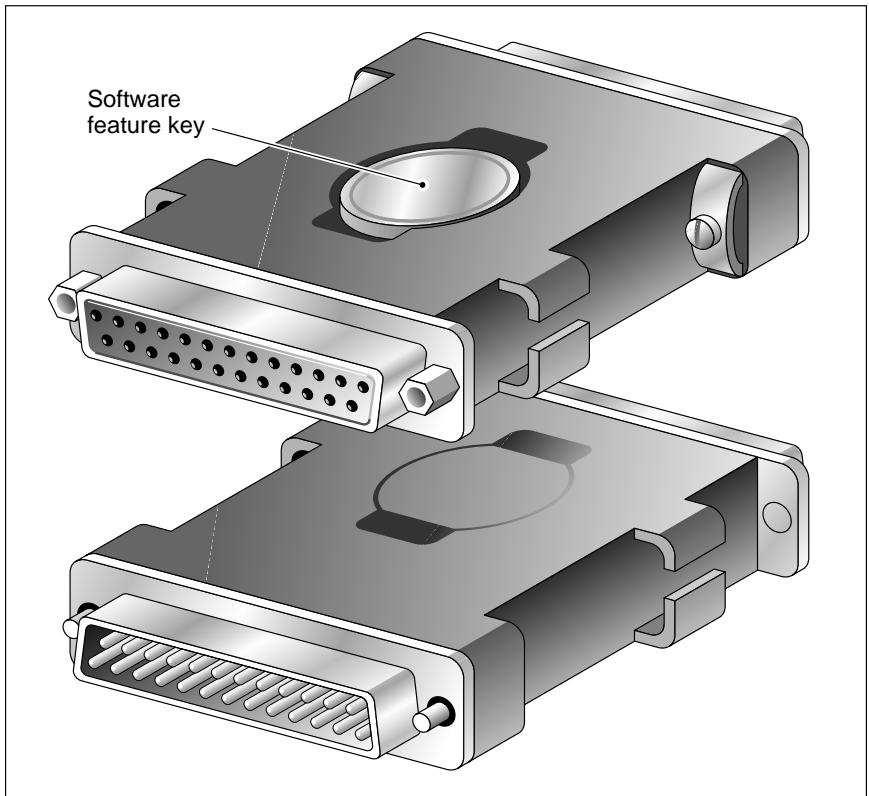

G101738

Requirements

For installation, you require a Phillips No. 1 screwdriver.

To install the software feature key adapter

- 1 Ensure that there is no cable connected to the parallel port.

Note: The parallel port is also known as the printer port or LPT1. It is located at the back of the server. See the diagram on page 59.

- 2 Plug the male end of the adapter into the parallel port.
- 3 Tighten the connector screws.

What's next?

Continue with “Connecting the server to power” on page 68.

Connecting the server to power

Before you begin

Ensure that proper power and grounding are available for all the power outlets serving the CallPilot server and its associated peripherals. Power for these devices must be wired and fused independently of all other receptacles and referenced to the same ground as the PBX system.

A qualified electrician must implement the single-point ground reference as required between the power outlets of the CallPilot server and the power outlets of the switch.

Provide a sufficient number of properly grounded power outlets or power bars for all equipment.

For more information, refer to Chapter 2, “Grounding and power requirements”, in the *CallPilot Planning and Engineering Guide*.

Before you connect the server to the power source, review the following diagram to ensure that all peripheral hardware devices are in place.

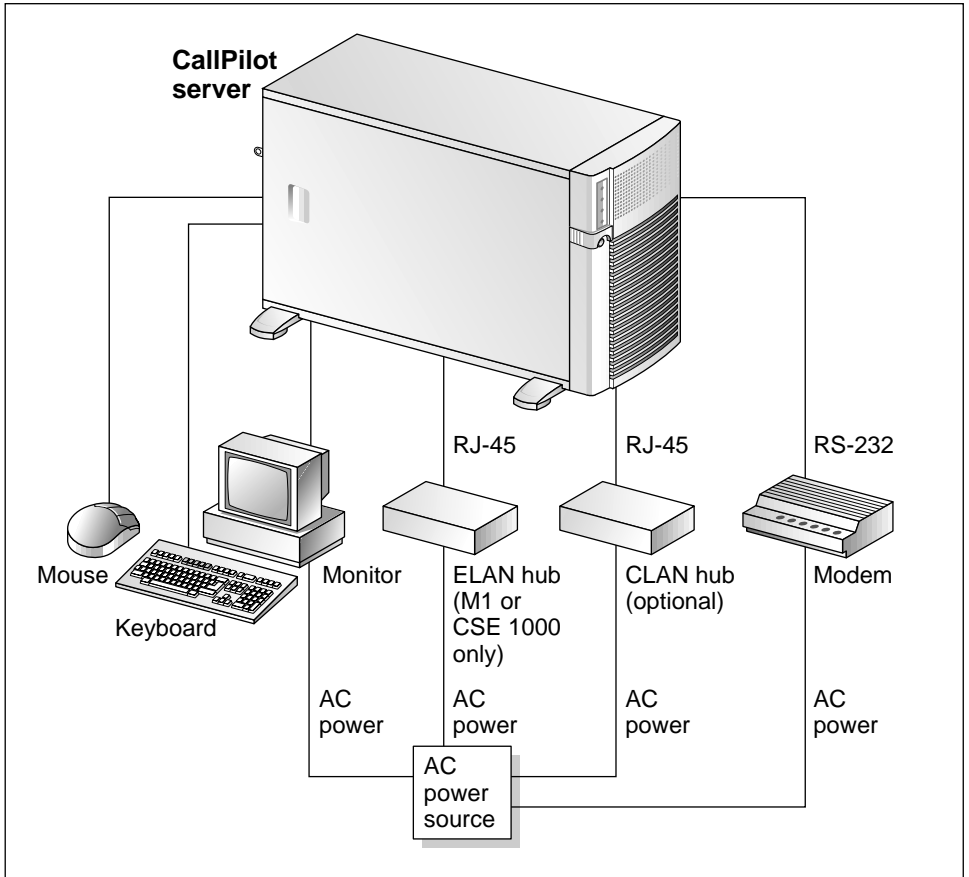

G101637

Note: For details on the DC power source for 1001rp DC servers, see Chapter 3, “Power supply installation.”

To connect the 1001rp AC server to power



CAUTION

Risk of personal injury and hardware failure

The power outlets that are used by the CallPilot server and its peripheral devices must be connected to the same single-point ground reference as the one used by the Meridian 1 switch or Succession CSE 1000 system. If this requirement is not met, power transients can cause personal injury and/or hardware failure.

- 1 Plug the server's AC power cord into the server's rear panel.
- 2 Plug the other end of the server's AC power cord into a properly grounded power outlet or power bar.

To connect the 1001rp DC server to power



DANGER

Risk of electrical shock

- Only qualified personnel can alter electrical connections.
- Ensure the PDU is turned off until you are instructed to turn it on.

- 1 Connect the DC power cable to the server, as shown below:

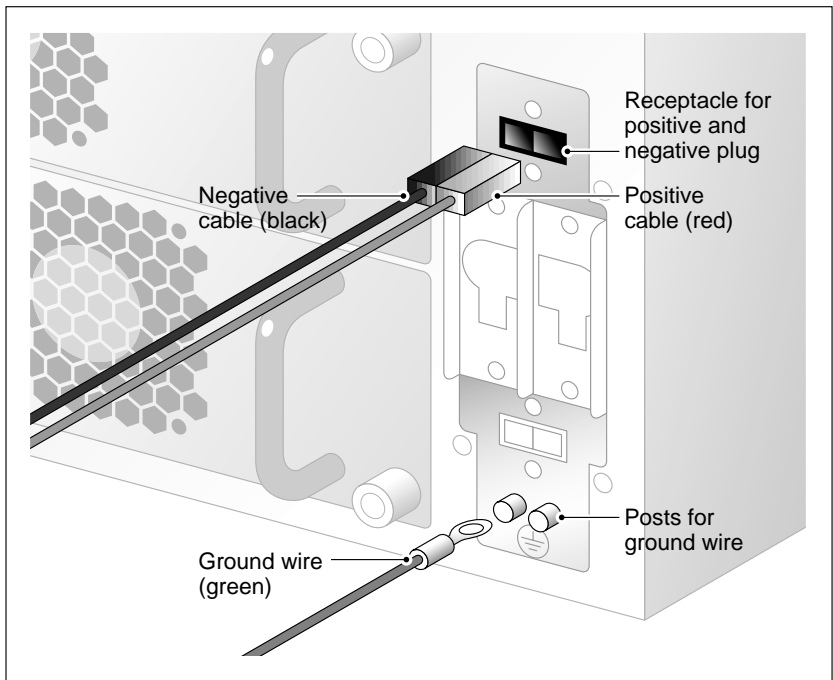

G101737

- 2 Connect the other end of the DC power cable to the Power Distribution Unit (PDU). See details below:

The following photograph shows the keyed plug of the DC power cable. This plug connects to the PDU:

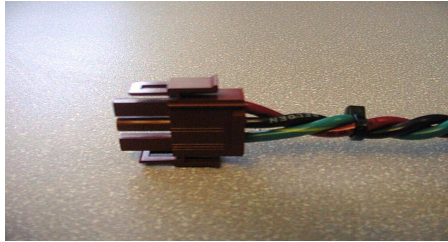

Note: If you are not using a Nortel Networks-supplied PDU, snip this plug and connect the cable appropriately to your DC power plant. Remember that a red cable is positive, a black cable is negative, and a green cable is the ground.

- 3 Turn on the PDU.

To start the server

- 1 Press the server's power switch to start the server.
- 2 Observe the Power-On Self-Test (POST) and initialization messages on the monitor.
- 3 When the following menu appears on the monitor, select option 1 to boot Windows NT:

Select one of the following:

```
-----  
1 Windows NT 4.0 Server (Default within 30 secs)  
2 Windows NT 4.0 Server (VGA mode)  
Choose an option[1,2]?1
```

The Windows NT startup sequence begins.

- 4 Ensure that the Windows NT logon window appears on the monitor.

Note: If the Windows NT logon window does not appear, refer to Part 5 of the *CallPilot Installation and Configuration* binder for troubleshooting instructions.

What's next?

If Windows NT started successfully, proceed with the switch and server set up as described in Part 3 of the *CallPilot Installation and Configuration* binder.

Index

A

- adapter
 - software feature key, illustration 66
- alarm board 11
- assigned board label
 - CallPilot Manager 16

C

- checklist
 - installation 26
- CLAN
 - media access control address 64
- CLAN network card faceplate 64
- connecting peripherals to the server 59
- connecting the server 68
- connectivity
 - Ethernet 22
 - remote 23
- Customer LAN
 - see CLAN 64

D

- DC power 47
- DC power and ground 50
- DC power input 49
- DC wire gauge tables 44
- devices, peripheral
 - Ethernet hub 24
 - keyboard 24
 - modem 24

- monitor 24
- mouse 24
- diagram
 - connection
 - network, M1 and CallPilot server 20
 - network, Succession CSE and CallPilot server 21
 - front panel 11
 - PCI and ISA connectors 13
 - rear panel
 - slot locations 12
 - server connections for the power cord and peripherals 59
- DIP switches
 - modem, function 57
- DIP switches, setting
 - modem 57
- dongle 66
- doors on the front bezel 31

E

- ELAN
 - Media Access Control address 62
- equipment
 - unpacking 29
- Ethernet hub
 - description 24

F

- fax modem
 - illustration 56

- required equipment 55
- features
 - server 10
- features, front panel
 - diagram 11
- front bezel 31, 32

G

- grounding guidelines 44

I

- illustration
 - modem 56
 - software feature key adapter 66
 - TLAN 21
- inspecting
 - server interior 35
- installation checklist 26
- IRQ mapping table 17

K

- keyboard
 - connecting to the server 60
 - description 24
- keylock 66

M

- M1 and CallPilot server network diagram 20
- MAC address
 - CLAN 64
 - ELAN 62
- Metric wire conversion 45
- modem
 - connecting to the server 60
 - description 24
 - DIP switches, setting 57

- illustration 56
- required equipment 55
- monitor
 - connecting to the server 60
 - description 24
- mouse
 - connecting to the server 60
 - description 24
- MPB16-4 board
 - slot number for M1 16
 - slot number for Succession CSE 1000 16

N

- network
 - protocols, supported 22
- network interface cards 22
- NIC
 - See* network interface cards

P

- part number
 - Ethernet hub 24
 - keyboard 24
 - modem 24
 - monitor 24
 - mouse 24
- PCI and ISA connectors
 - diagram 13
- PDU 48
 - multiple PDUs 49
 - single PDU wiring diagram 49
- peripheral devices
 - Ethernet hub 24
 - keyboard 24
 - modem 24
 - monitor 24
 - mouse 24
- peripherals
 - connecting to the server 59
- power connection

- AC server 70
- DC server 71
- power distribution rationale 47
- Power Distribution Unit
 - See* PDU
- power guidelines 44
- power supply
 - bringing power and ground into the PDU 50
 - DC wire gauge tables 44
 - grounding guidelines 44
 - Metric wire conversion 45
 - module installation 42
 - module location 40
 - overview 40
 - PDU 48
 - power distribution rationale 47
- protocols, supported network 22

R

- remote access
 - connectivity 23
- removing
 - front bezel 32
 - server cover 33
- replacing
 - server cover 36

S

- safety information 38
- serial number of the server 66
- server
 - connecting peripherals 59
 - power connection 68
 - serial number 66
- setting
 - modem DIP switches 57
- slot assignments 14
- slot definition 14
- slot numbering 14

- software feature key 66
- Succession CSE 1000 and CallPilot server
 - network diagram 21
- switches, setting DIP
 - modem 57

T

- tables, slot assignment 14
- telephony LAN
 - See* TLAN
- TLAN
 - illustration 21

U

- unpacking
 - equipment 29

CallPilot

Installation and Configuration

Part 2: 1001rp Server Hardware Installation

Copyright © 2003 Nortel Networks, All Rights Reserved

Information is subject to change without notice. Nortel Networks reserves the right to make changes in design or components as progress in engineering and manufacturing may warrant.

The process of transmitting data and call messaging between the CallPilot server and the Meridian 1 switch or Succession CSE 1000 system is proprietary to Nortel Networks. Any other use of the data and the transmission process is a violation of the user license unless specifically authorized in writing by Nortel Networks prior to such use. Violations of the license by alternative usage of any portion of this process or the related hardware constitutes grounds for an immediate termination of the license and Nortel Networks reserves the right to seek all allowable remedies for such breach.

Publication number: 555-7101-217
Product release: 2.02
Document release: Standard 1.0
Date: May 2003

Printed in Canada



Free Manuals Download Website

<http://myh66.com>

<http://usermanuals.us>

<http://www.somanuals.com>

<http://www.4manuals.cc>

<http://www.manual-lib.com>

<http://www.404manual.com>

<http://www.luxmanual.com>

<http://aubethermostatmanual.com>

Golf course search by state

<http://golfingnear.com>

Email search by domain

<http://emailbydomain.com>

Auto manuals search

<http://auto.somanuals.com>

TV manuals search

<http://tv.somanuals.com>