

# Digital Temperature Controller

(KIT P/N 36939)

## Installation, Programming and Troubleshooting Instructions

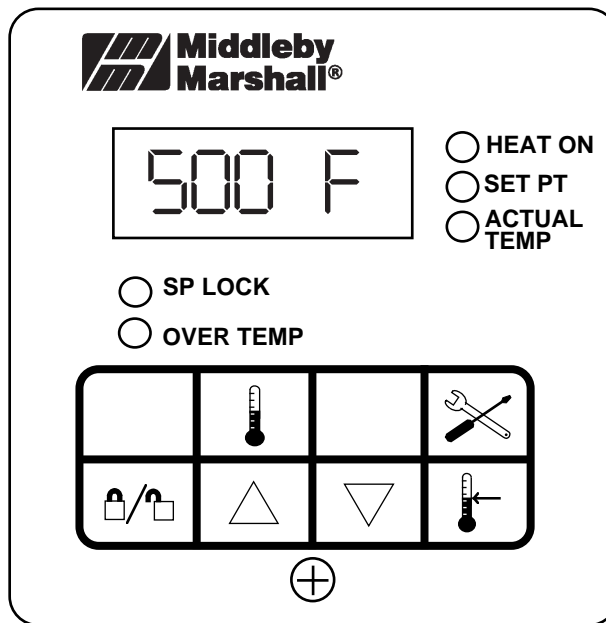

### Kit Contents

Qty	Part Number	Description
1	36056	On/Off-PID Digital Temperature Controller w/brackets
1	36622	Installation, Programming, and Troubleshooting Instructions
1	36940	Operators Instructions

Middleby Marshall Inc. • 1400 Toastmaster Drive • Elgin, IL 60120 • (847) 741-3300 • FAX (847) 741-4406  
**Middleby Corporation 24 Hour Service Hotline 1-800-238-8444**

# INSTALLATION INSTRUCTIONS

This manual provides instructions for conversion:

<u>from</u>	<u>to</u>
Analog Temperature Controller (A), PN 28071-0012 ( <u>without</u> high-limit and cool down function).....	to (F) Digital Temperature Controller, PN 36056
Analog Temperature Controller (A), PN 28071-0018 ( <u>with</u> high-limit and cool down function).....	
Digital Temperature Controller (B), PN 28071-0027 (with blue plastic face).....	
Digital Temperature Controller (C), PN 28071-0028 (with gray rubberized face and no symbols).....	
Digital Temperature Controller (D), PN 28071-0028 (with gray rubberized face and symbols).....	
Digital Temperature Controller (D), PN 30871 (with gray rubberized face set for "high voltage"; CE & 360WB-70).....	
Digital Temperature Controller (D), PN 32571 (360EWB modulating system with gray rubberized face set for "high voltage").....	
Digital Temperature Controller (E), PN 36021 (gray metal face with silver boarder multi-voltage ready [100 - 260 V]; for all models including CE).....	

A

B

C

D

E

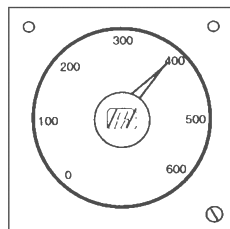

PN 28071-0012  
PN 28071-0018

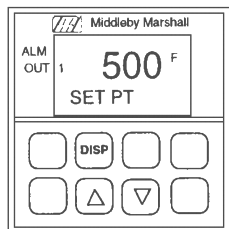

PN 28071-0027

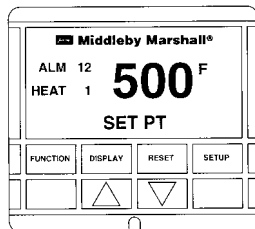

PN 28071-0028

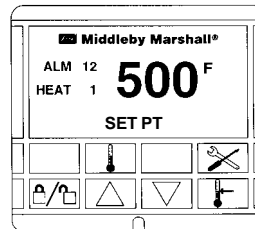

PN 28071-0028  
PN 30871  
PN 32571

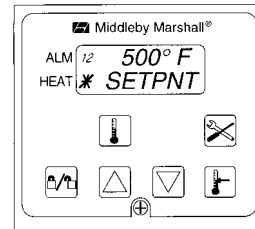

PN 36021

### NOTE

The replacement temperature controller, PN 36056, replaces all former model temperature controllers. Therefore, this control is designed to operate on all old and current model Middleby Marshall ovens. **A CURRENT VERSION THERMOCOUPLE IS REQUIRED FOR PROPER OPERATION OF THE LATEST TEMPERATURE CONTROLLER P/N 36056.** SEE THE WIRING SECTION OF THESE INSTRUCTIONS FOR DETAILS.

### CAUTION

When installing the controller, PN 36056, into a model 360EWB, the control must be programmed to operate on the mA output terminals 15 and 16. Refer to Instructions.

F

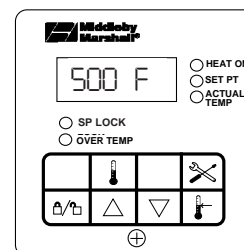

PN 36056

## Unpacking

The Digital Temperature Controller was checked before leaving the factory. Inspect the shipping container carefully for evidence of improper handling during shipment. In case of damage, make an immediate claim to the parts distributor from whom the unit was purchased. If the Digital Temperature Controller was shipped to you, notify the carrier without delay and file a claim.

The installation process consists of:

- Disconnecting the existing wiring and removing the existing Temperature Controller.
- Mechanically installing the replacement Digital Temperature Controller.
- Making the appropriate electrical connections.

When the installation is completed, check the Digital Temperature Controller for the desired oven operation. Also, demonstrate the use of the Digital Temperature Controller for the owner (operator) and leave a copy of the Operating Instructions (PN 36940).

## Disconnecting Existing Wires / Mechanical Installation

The following provides mechanical installation instructions for the Digital Temperature Controller.

<p style="text-align: center;"><b>WARNING</b></p> <p><b>To avoid electrical shock hazard, shut OFF all electrical power to the oven at the disconnect switch or circuit breaker before installing the Digital Temperature Controller.</b></p>
---

To remove the Existing Temperature Controller and to install the latest Digital Temperature Controller, proceed as follows:

Replacing an **Analog Temperature** Controller with the latest Digital Controller

- | <u>Step</u> | <u>Procedure</u>  |
|-------------|---|
| 1.          | Disconnect all associated wiring from the terminals located on the rear of the Temperature Controller. Disconnect and retain any jumper wires. Be sure to tag the ends of controller wires with the number terminal they connect to. These old numbers will be used later to match them with the new Digital control terminal numbers as referenced in Table 1. |
| 2.          | Unscrew the two bracket screws and remove the bracket securing the control to the oven. Slide the bracket away from the controller. Remove the controller by pulling it out through the front of the panel.   |
| 3.          | Go to "Installing the Digital Controller" on next page.   |

Replacing any **Digital Temperature** Controller with the latest Digital Controller

- | <u>Step</u> | <u>Procedure</u>   |
|-------------|--|
| 1.          | When converting a Digital Temperature Controller, PN 28071-0027, PN 28071-0028, PN 30871, or PN 36021, to the latest digital controller, tag the wires and replace wire for wire since the terminal connections are exactly the same. If replacing an existing 360EWB temperature controller, PN 32571, be sure to tag the mA output terminal wires for proper cross reference to the new controller as called out in step 4 under "Electrical Connections". |
| 2.          | Remove the two clip style brackets on the top and bottom of the control. Remove the controller by pulling it out through the front of the panel. See Figure 1.   |

## Installing the Digital Controller

- | Step | Procedure   |
|------|---|
| 1.   | Insert the Digital Temperature Controller into the same panel slot making sure the face of the controller is upright with the display on top and the push buttons on the bottom.  |
| 2..  | Identify the two rectangular holes on top and bottom of the control case. Attach the two panel mounting brackets with the clips of the brackets and the heads of the screws pointing towards the rear of the new controller into these rectangular holes. See Figure 1. |
| 3..  | Tighten both screws evenly against the back side of control panel until the controller seats securely.  |

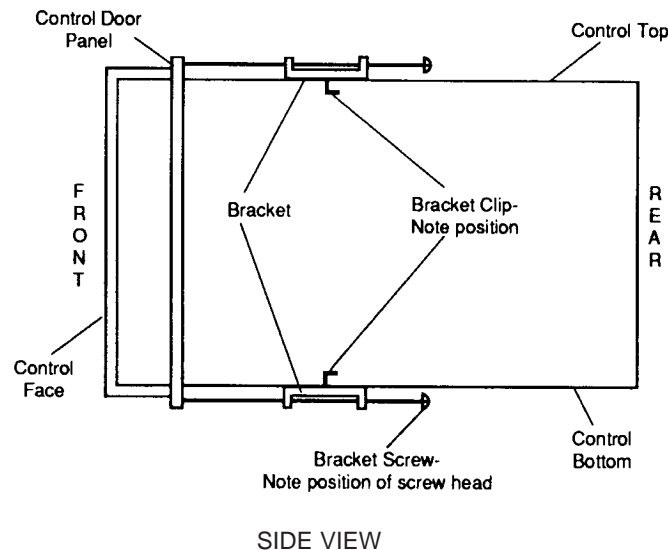

**Figure 1 - Mounting Bracket Clip and Screw Position**



## Electrical Connections

All electrical connections on the Digital Temperature Controller are made on two terminal strips located on the rear of the controller case. The existing oven wires are connected to the new terminal positions indicated in the analog to digital terminal cross reference in Figure 2.

Proceed as follows to make electrical connections:

1. Use Figure 2 and Table 1 to identify the electrical connections. Also refer to step 4 if installing the latest Temperature Controller for the Modulating Configuration used in a 360EWB oven.
2. If you are replacing an Analog Controller, refer to the discontinued Analog Temperature Controller terminal numbers which are shown in brackets ([ ]) next to the matching Digital Controller terminal. **NOTE:** All wires, including jumpers, will be reused from the existing temperature controller (analog or digital) with the new replacement digital temperature controller. **CAUTION:** DO NOT USE TERMINALS 15 & 16 ON THE "DIGITAL" TEMPERATURE CONTROLLER OR DAMAGE TO THE CONTROL WILL RESULT!
3. If you are replacing an existing Digital Temperature Controller with the latest Digital Temperature Controller, PN 36056, then simply ignore the bracketed terminal numbers which pertain to the Analog Controllers only and reconnect the same wires.
4. If you are replacing a Modulating Digital Temperature Controller, PN 32571, with the latest digital temperature control, PN 36056, be aware that the mA output terminals of the Temperature Controller, which feed the Amplifier Board, change from **4 & 5** to **15 & 16**. See Figure 3.

Table 1 - Terminal Cross Reference

TERMINAL ON OLD MODULE: 	DESCRIPTION OF TERMINAL	TERMINAL ON NEW MODULE: 
1	+ T/C	8
2	- T/C	7
5	Input to Temperature Control Relay	5
6	Output to High Flame Solenoid or Heater Contactors	4
L2	Neutral	L2
L1	Power	L1
G	Ground	
13	Input to Cool-Down Relay	9
14	Output from Cool-Down Relay	10
15	Input to High-Limit Relay	11
16	Output from High-Limit Relay	12
N/A	Modulating Valve Output Terminals (360EWB ONLY)	15 16

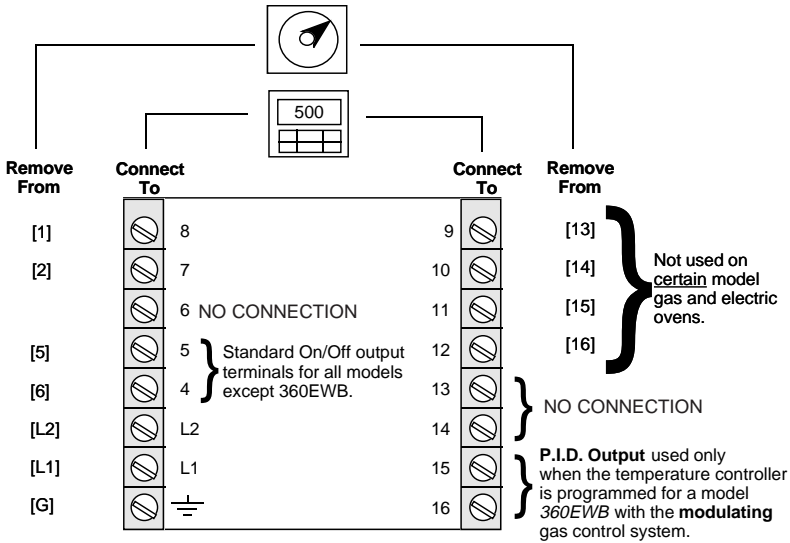

Figure 2 - Analog to Digital Terminal Cross Reference

Move wires at terminals 4 & 5 to 15 & 16 for the model 360EWB only

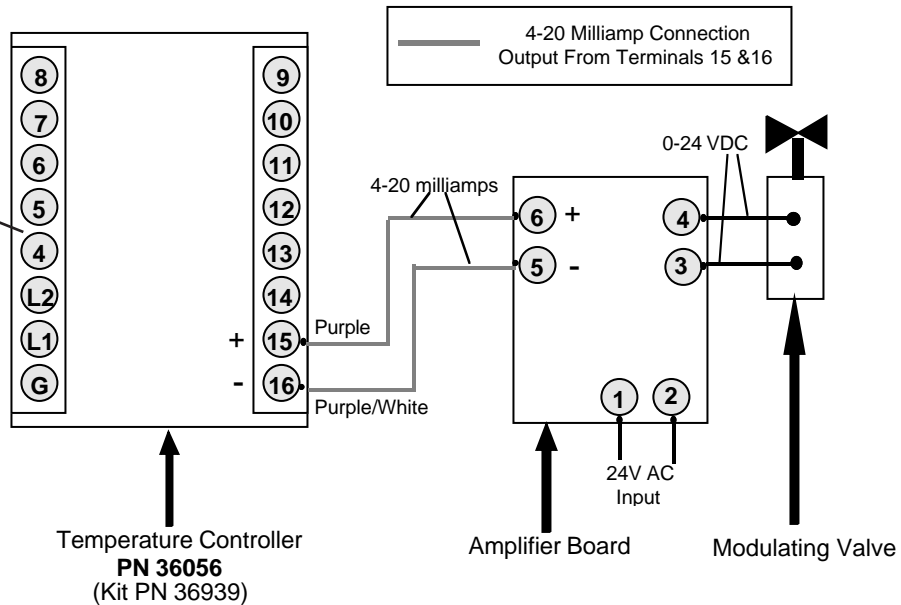

Figure 3 - Modulating Control Circuit

5. Check to be sure the oven's thermocouple is the latest version flange mount style versus the obsolete version. See Figure 4 below.

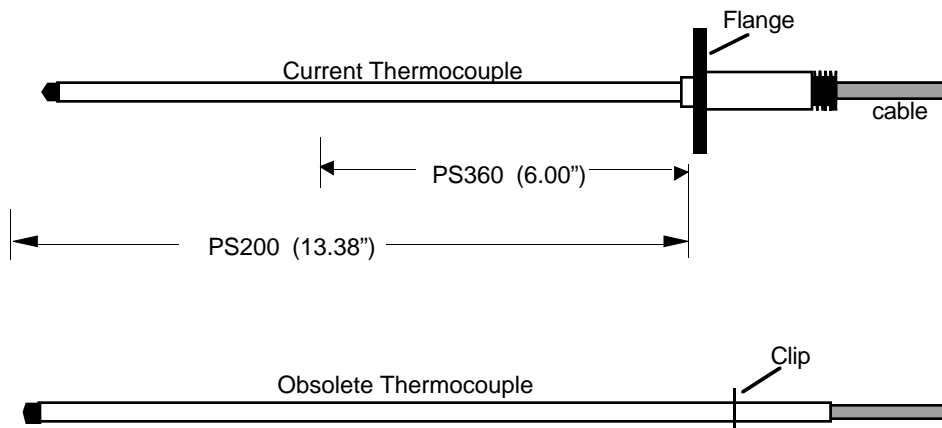

Figure 4 - Current & Obsolete Thermocouple Comparison.

The obsolete thermocouple is not compatible with the latest temperature controller, p/n 36056, and must be replaced with the latest thermocouple, kit p/n 33984 (300 Series ovens), and kit p/n 33985 (200 Series ovens). The obsolete thermocouples leads are grounded to the protective sheathing which causes an error signal with the latest controller's thermocouple circuit.

6. After becoming familiar with the various electrical connections pertaining to the specific model oven and its temperature controller, refer to table 2 for specific wiring instructions for all wires and any jumpers to be reinstalled.

**NOTES:**

---

---

---

---

---

---

---

---

---

---

**NOTE**  
**Be sure to replace any jumper wire specified  
in the wiring diagram.**

Table 2 - Wiring Configurations

Oven Model Number	Related Figure
PS200 Gas Oven, 208-240V, 50/60Hz, 1 Ph, 3W.....	Figure 5
PS200 Gas Oven, 200V, 50/60Hz, 1 Ph, 2W (Export Only).....	Figure 5
PS200 Gas Oven, 208V, 50/60Hz, 1 Ph, 2W (Export Only).....	Figure 5
PS200 Gas Oven, 220-240V, 50/60Hz, 1 Ph, 2W (Export Only).....	Figure 5
PS200 Electric Oven, 208-240V, 50/60Hz 3Ph, 4W (for models built before December 1996).....	Figure 8
(for models built in December 1996 and later).....	Figure 9
PS200 Electric Oven, 380V, 50/60Hz, 3Ph, 4W (Export Only) (for models built before December 1996).....	Figure 8
(for models built in December 1996 and later).....	Figure 9
PS200 Electric Oven, 400-416V, 50/60Hz, 3Ph, 4W (Export Only) (for models built before December 1996).....	Figure 8
(for models built in December 1996 and later).....	Figure 9
PS250 Gas and Electric Ovens with <u>early style</u> .....	Figure 7
Analog Controller Part Number 28071-0009	
PS250 Gas and Electric Ovens with <u>later style</u> .....	Figure 6
Analog Controller Part Number 28071 -0012	
PS300/304/350 (All Gas and Electric Ovens are the same).....	Figure 6
PS310/314/360, 360WB Gas Oven, 208-240V, 50/60Hz, 1Ph, 3W.....	Figure 5
PS310/314/360, 360WB Gas Oven, 208-240V, 50/60Hz, 1 Ph, 2W (Export Only).....	Figure 5
PS310/314/360, 360WB Gas Oven, 190-380V, 50/60Hz, 1Ph, 2W (Export Only).....	Figure 5
PS310/314/360, Electric Oven, 200-220V, 50/60Hz, 3Ph, 3W (Export Only).....	Figure 6
PS310/314/360, Electric Oven, 208-240V, 50/60Hz, 3Ph, 4W.....	Figure 6
(with Single Phase Blower Motors)	
(with 3 Phase Blower Motors).....	Figure 6
PS310/314/360, Electric Oven, 240V, 50/60Hz, 3Ph, 3W.....	Figure 6
PS310/314/360, Electric Oven, 380V, 50/60Hz, 3Ph, 3W (Export Only).....	Figure 5
PS310/314/360, Electric Oven, 480V, 50/60Hz, 3Ph, 3W.....	Figure 5
PS310/314/360, Electric Oven, 400-440V, 50/60Hz, 3Ph, 3W (Export Only).....	Figure 5
PS360WB-70 Gas Oven, 208-240V, 50/60HZ, 1Ph, 3W.....	Figure 10
PS360EWB Gas Oven, 208-240V, 50/60HZ, 1Ph, 3W.....	Figure 11
PS570 Gas Oven, All Units.....	Figure 9
PS200 Gas <b>CE</b> Oven, All Units.....	Figure 12
PS200 Electric <b>CE</b> Oven, All Units.....	Figure 13
PS360/360WB Gas <b>CE</b> Oven, All Units.....	Figure 12
PS360/360WB Electric <b>CE</b> Oven, All Units.....	Figure 13

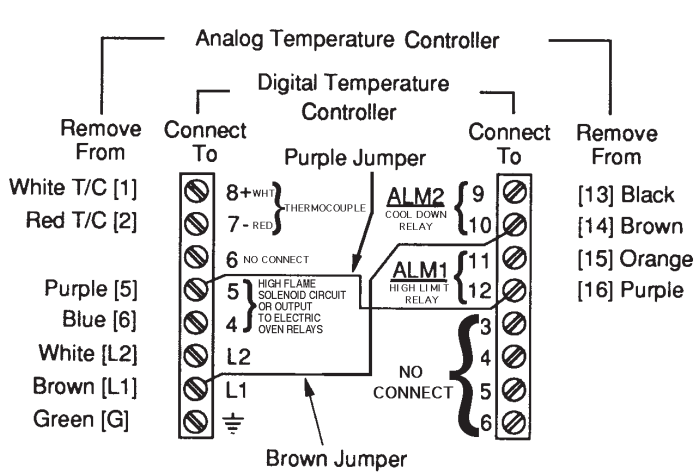

Figure 5 - Wiring Diagram Showing Electrical Connections (Refer to Table 2)

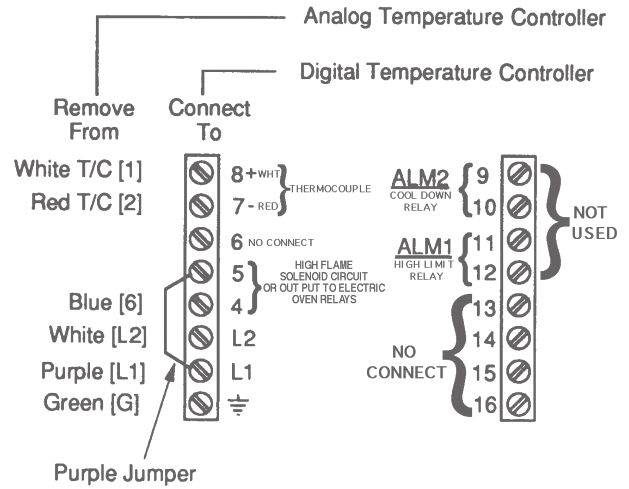

Figure 6 - Wiring Diagram Showing Electrical Connections (Refer to Table 2)

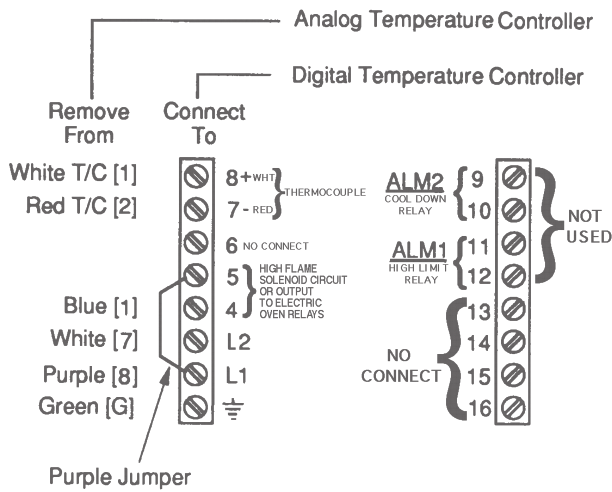

Figure 7 - Wiring Diagram Showing Electrical Connections (Refer to Table 2)

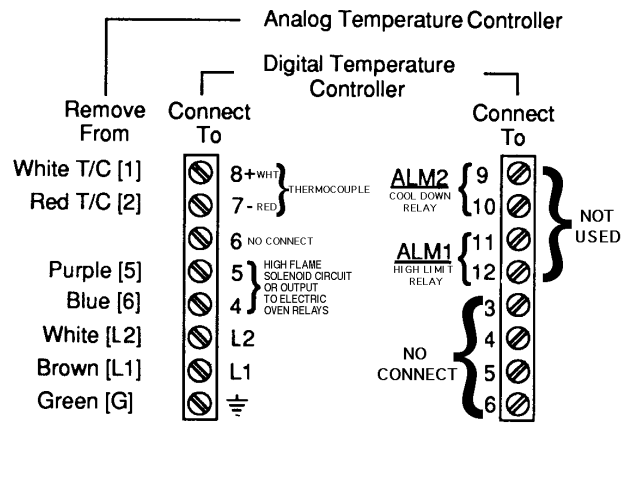

Figure 8 - Wiring Diagram Showing Electrical Connections (Refer to Table 2)

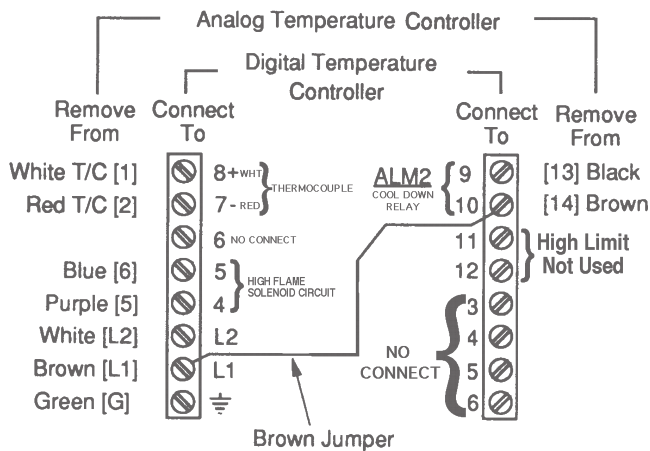

Figure 9 - Wiring Diagram Showing Electrical Connections (Refer to Table 2)

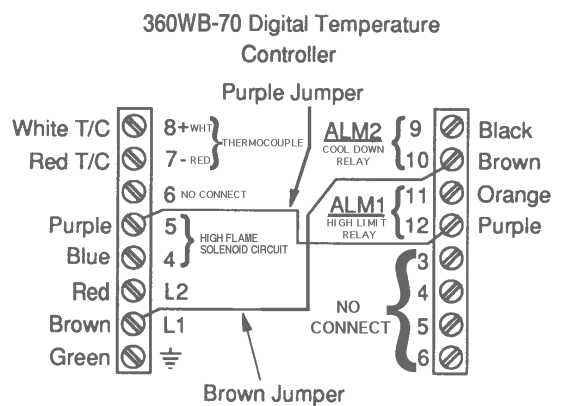

Figure 10 - Wiring Diagram Showing Electrical Connections (Refer to Table 2)



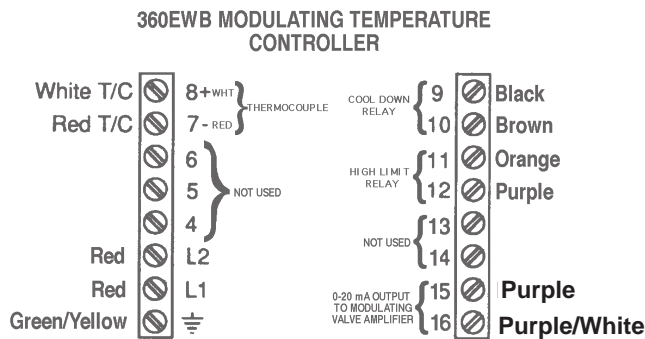

Figure 11 - Wiring Diagram Showing Electrical Connections (Refer to Table 2)

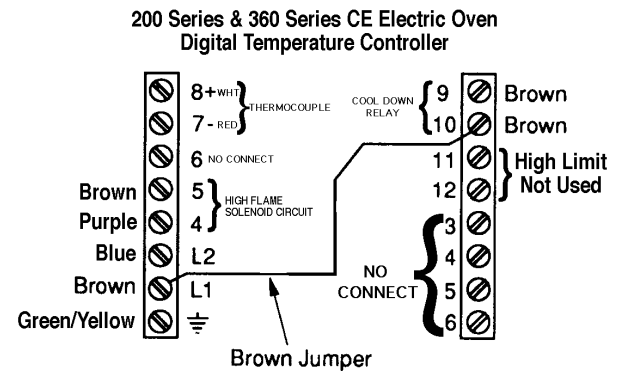

Figure 12 - Wiring Diagram Showing Electrical Connections (Refer to Table 2)

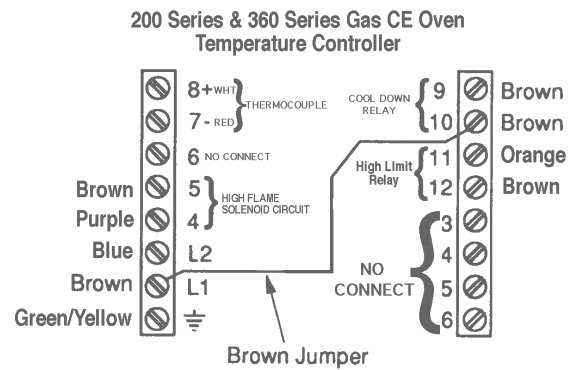

Figure 13 - Wiring Diagram Showing Electrical Connections (Refer to Table 2)

## Programming

After the Digital Temperature Control has been properly installed and wired, it is ready to be programmed for either the standard on/off cycling gas solenoid/electric heating system, or the modulating gas valve system. Then, as requested by the customer, the controller can be set for set lock configuration, F or C operation, and the display type. This function is to be done by the authorized technician. See Figure 14 Service Instructions for details. NOTE: The temperature controller is pre-programmed for On/Off operation, open set lock, and set point display.

Once the Digital Temperature Control has been service programmed, it then can be operator programmed for set point. See Figure 15 Operator Instructions for details.

Be sure to thoroughly go over the Operator Instructions with the customer to be sure they are familiar with the new control. Leave the spare copy of the Operator Instructions, PN 36940, with the customer for their future reference.

A copy is enclosed with the new temperature control.

## Digital Temperature Controller PN 36056 Service instructions

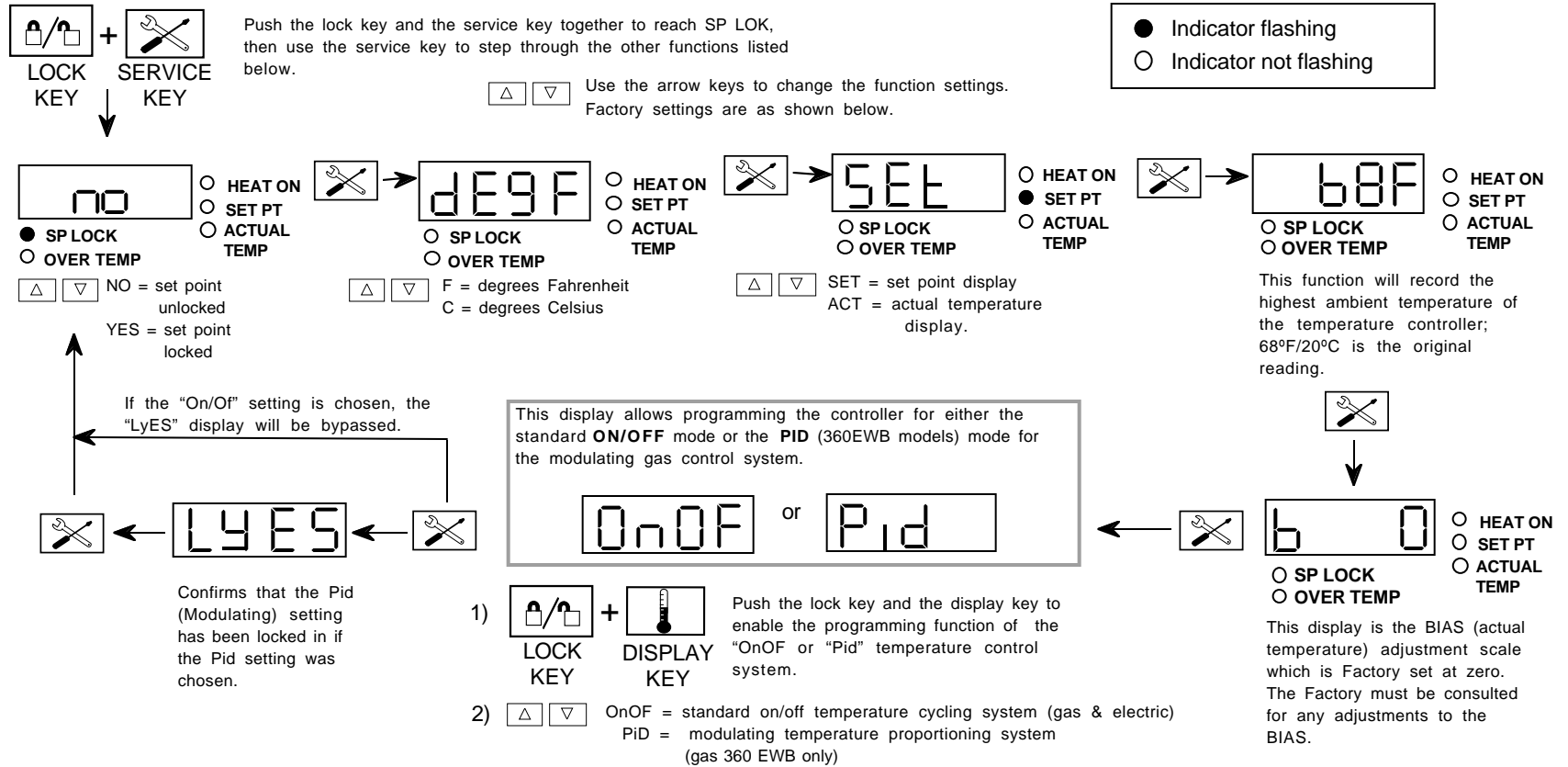
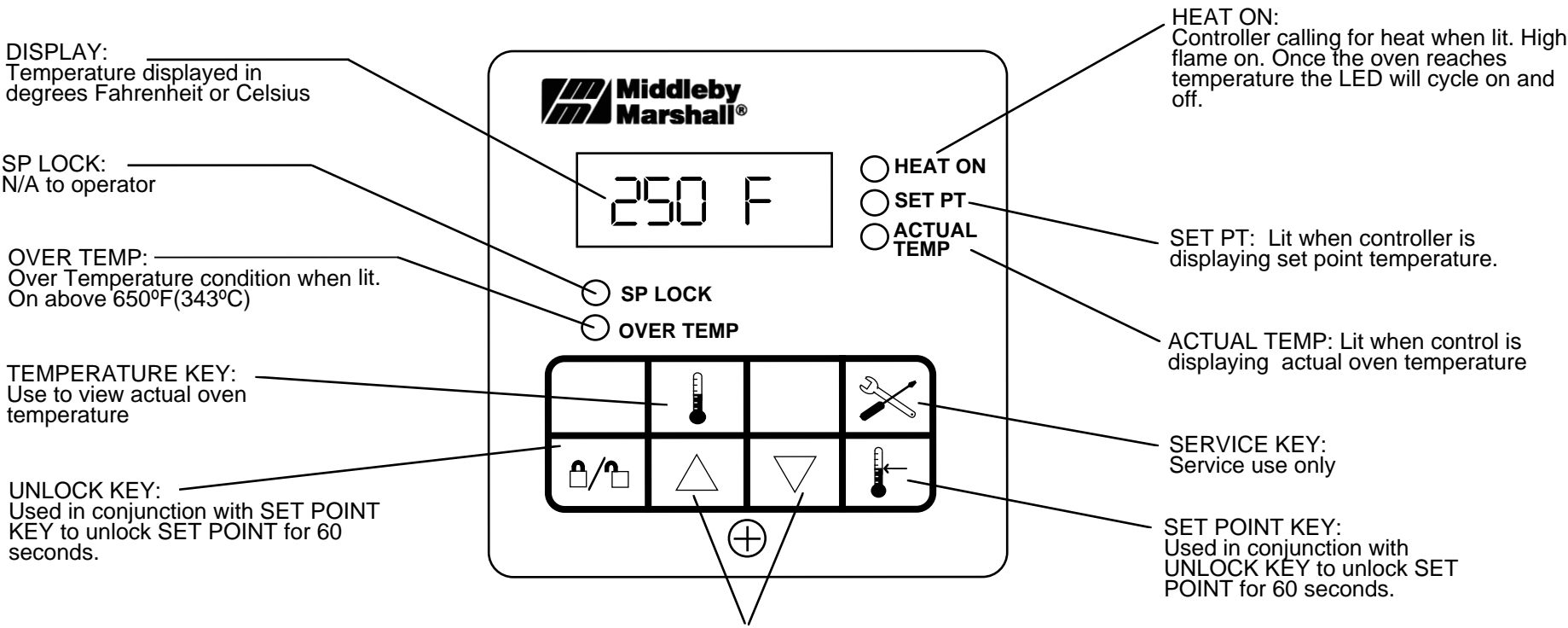

Figure 14 - Service Instructions

# Digital Temperature Controller P/N 36056 Operators Instructions



UP and DOWN arrow keys:  
Used to change the set point.

If SET POINT will not change  
and lower display flashes then  
see below



Press UNLOCK & SET POINT  
keys simultaneously to unlock  
set point, UP & DOWN keys will  
now function for 60 seconds.

Figure 15 - Operators Instructions

## Diagnostic Error Messages

The controller runs background tests during normal operation. If a problem with the background tests occurs, an error message is shown (flashing) in the Display. These are called Diagnostic Error Messages (**Table 3**).

Table 3 - Diagnostic Error Messages

Display	Corrective Action
<p><b>rPLC</b></p> <p>Flashes on the display alternately with temperature indicating that the controller's internal diagnostics test has failed.</p>	<ol style="list-style-type: none"> <li>1. Turn Blower Switch OFF for 2 minutes, then Turn Blower Switch ON.</li> <li>2. Replace the controller if the problem does not clear after repeating action 1 above three times.</li> </ol>
<p><b>rSET</b></p> <p>Oven temperature has not reached at least 200°F(93°C) within 15 minutes of operation; usually a result of the burner not lighting.</p>	<ol style="list-style-type: none"> <li>1. Turn Blower Switch OFF for 2 minutes, then Turn Blower Switch ON.</li> <li>2. If problem does not clear, call the Middleby Cooking Systems Group (MCSG) for assistance.</li> </ol>
<p><b>OPEn</b></p> <p>Caused by an open circuit in the thermocouple circuit.</p>	<ol style="list-style-type: none"> <li>1. Check that the thermocouple is connected to terminals 7 &amp; 8 of the temperature controller.</li> <li>2. If connections are good, then check the continuity of the thermocouple at room temperature. The resistance reading should be in the 9 - 20 Ohm range. Remove &amp; replace an open thermocouple.</li> <li>3. If the thermocouple checks good, call MCSG for assistance.</li> </ol>
<p><b>r TC</b></p> <p>Reverse polarity of the thermocouple leads.</p>	<ol style="list-style-type: none"> <li>1. Check the polarity of the thermocouple leads; terminal 7 (-) RED wire &amp; terminal 8 (+) WHITE wire.</li> <li>2. If polarity connections are correct replace thermocouple.</li> </ol>

Middleby Marshall Inc. • 1400 Toastmaster Drive • Elgin, IL 60120 • (847) 741-3300 • FAX (847) 741-4406  
**Middleby Corporation 24 Hour Service Hotline 1-800-238-8444**

## Free Manuals Download Website

<http://myh66.com>

<http://usermanuals.us>

<http://www.somanuals.com>

<http://www.4manuals.cc>

<http://www.manual-lib.com>

<http://www.404manual.com>

<http://www.luxmanual.com>

<http://aubethermostatmanual.com>

Golf course search by state

<http://golfingnear.com>

Email search by domain

<http://emailbydomain.com>

Auto manuals search

<http://auto.somanuals.com>

TV manuals search

<http://tv.somanuals.com>