



CARRIER COMMERCIAL REFRIGERATION, INC.

Providing BEVERAGE-AIR • FRIGIDAIRE • KELVINATOR • UNIVERSAL NOLIN Products/Services

SERVICE & INSTALLATION MANUAL



Frozen Food & Ice Cream Merchandisers CMCT

If additional information is necessary, call the factory.

Our toll free number is **1-800-684-1199**. Technical assistance engineers are willing to assist you in any way possible. Office hours are from 8:00a.m. to 5:30 p.m., Eastern Standard Time.

Important information is contained in this manual which should be retained in a convenient location for future reference.

All data and information in this manual is subject to change without notice.

MODEL DESIGNATION INFORMATION		
115V, 60HZ		
PART #	MODEL #	DATA PLATE
52-2038-01	CMCT4-4	SL12/CMCT4
52-2038-03	CMCT6-4	SL20/CMCT6
52-2038-05	CMCT8-4	SL28/CMCT8
52-2038-06	CMCT10-4	SL36/CMCT10
EXPORT 220V, 50HZ		
PART #	MODEL #	DATA PLATE
52-2040-01	ECMCT4-4	ECMCT4
52-2040-02	ECMCT6-4	ECMCT6
52-2040-04	ECMCT8-4	ECMCT8

SECTION I

Introduction

CMCT Merchandisers – Introduction

These cabinets are produced for the merchandising of frozen food and ice cream markets. They range in size from 4' to 10' in length. Operating ambients range from 70°F. to 85°F. with cavity temperatures at load line between 0°F. to -20°F.

Except for routine cleaning, these cabinets will require little maintenance. In the unusual event that repair should be necessary, this manual presents information that is helpful in maintaining, diagnosing, and repairing these cabinets.

TABLE OF CONTENTS

INTRODUCTION

Introduction	3
Table of Contents	4
Specifications & Illustrations	5
Handling & Installation	6
Cleaning Instructions	7
Cabinet Operation	7
Electrical Data	9
Refrigeration/Electrical Specs. (R404A).....	10
Refrigeration/Electrical Data Export Models.....	11
Wiring Diagram CMCT Models 4, 6 & 8	12
Wiring Diagram CMCT Models 10	13
Wiring Diagram ECMCT Models 4, 6 & 8 (Export)	14
Lamp Wiring Detail (Upper Raceway)	15

MAINTENANCE & REPAIR

Cabinet Temperature Control	19
Electrical Box Layout	20
Defrost Timer Layout	21
Cabinet Electrical Supply	22
Condensing Unit Assembly	23
Condensing Unit Layout.....	24
Unit Compartment - Rear.....	25
Evaporator Tubing Illustration	26
New Lubricants	27
Back Pressure Valve	28
Light Channel Assembly	29
Baffle Heater comp. ID & Removal	30
End Panel Breaker & Heater Removal	31
Refrig. Upper Section Comp. ID & Removal	32
Upper Cross Section	33
Front Glass Heater Replacement	34
Countertop	35
Evaporator Coil Removal	36
Troubleshooting Guide.....	38

PARTS LISTS

CMCT Cabinet Exterior Parts ID	40
Parts List CMCT-4, 6, 8 & 10.....	41
Parts List EMCT-4, 6 & 8.....	42

Due to the manufacturer's policy of continuous quality improvement, specifications are subject to change without notice.

Specifications - Specifications Subject to Change without Notice.

	CMCT-4	CMCT-6	CMCT-8	CMCT-10
Temperature Range	0° to -20°F	0° to -20°F	0° to -20°F	0° to -20°F
Insulation	2½" Urethane Foam in Place	2½" Urethane Foam in Place	2½" Urethane Foam in Place	2½" Urethane Foam in Place
Number of Lids	2	2	3	4
Lid Construction	3/16" Glass Radiant Heated	3/16" Glass Radiant Heated	3/16" Glass Radiant Heated	3/16" Glass Radiant Heated
Capacity	11 cu. ft.	19 cu. ft.	27 cu. ft.	35 cu. ft.
Capacity (1/2 gallons)	120	225	322	435
Novelty Baskets Load Level	10	14	20	26
Capacity Novelty Baskets Total	16	24	36	48
Shipping Weight (Approx.)	486 lbs.	624 lbs.	780 lbs.	874 lbs.
Compressor Size	1/2 HP	1/2 HP	3/4 HP	1 HP
Condenser Type	Bare Tube Forced Air	Bare Tube Forced Air	Bare Tube Forced Air	Fin & Tube Forced Air
Evaporator Type	Fin & Tube Gravity Coil & Cold Wall	Fin & Tube Gravity Coil & Cold Wall	Fin & Tube Gravity Coil & Cold Wall	Fin & Tube Gravity Coil & Cold Wall
Refrigerant Type	R404A	R-404A	R-404A	R-404A
Refrigerant Control	Capillary	Capillary	Capillary	Capillary
Defrost System	Electric	Electric	Electric	Electric
Rated Amps	8.0	8.0	12	4.8 (11V0/6.7 (230V))
Electrical Specs. (V/Hz/Ph)	115/60/1	115/60/1	115/60/1	115 & 230/60/1
Power Cord	15 Amp Cord with 5-15P NEMA Plug	15 Amp Cord with 5-15P NEMA Plug	15 Amp Cord with 5-15P NEMA Plug	Conduit Connected / Max. Fuse Size 15A Min. Circuit Ampacity 15A
NSF-7 (Ice Cream Storage)	Yes	Yes	Yes	Yes
UL & CUL Listed	Yes	Yes	Yes	Yes
Interior Finish	White Baked Enamel	White Baked Enamel	White Baked Enamel	White Baked Enamel
Exterior Finish	White Baked Enamel	White Baked Enamel	White Baked Enamel	White Baked Enamel
Lighted Sign	Standard	Standard	Standard	Standard

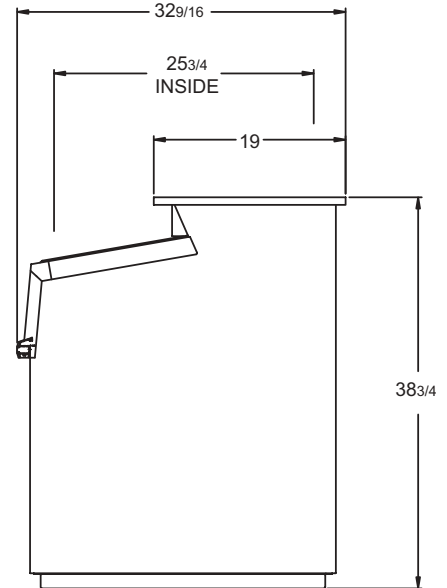
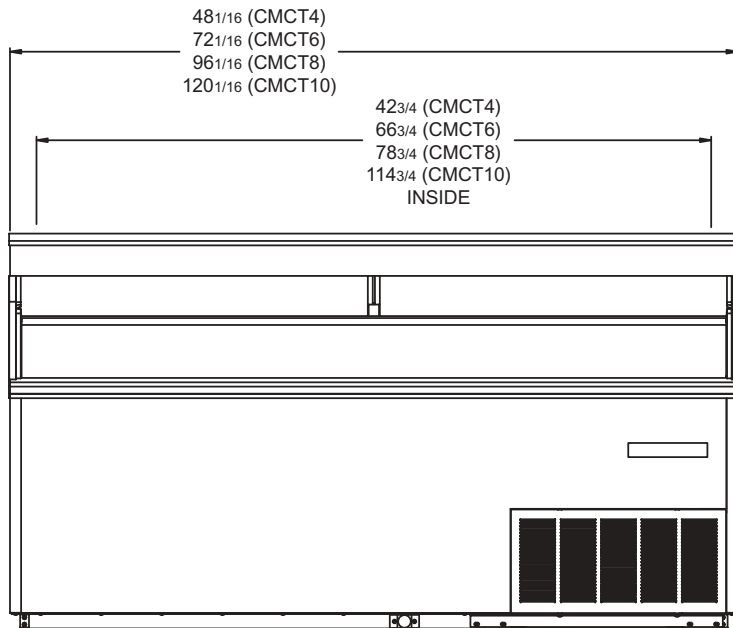

SECTION I – HANDLING & INSTALLATION

FREIGHT DAMAGES AND SHORTAGES

IMPORTANT: The cabinet was inspected and packaged at the factory, and should arrive in excellent condition. The transportation company or other parties involved in the shipment are responsible for loss and/or damage. Always make an inspection before and after uncrating. Inspect the crated unit(s) before locating (preferably at the point of unloading by the transportation company).

INSPECTING FOR DAMAGES

NOTE: *Always use care when removing shipping tape, blocks, pads, hardware or other material until you are satisfied that the unit is completely operational.*

Check the cartons or containers. If these are damaged in any way, open them and inspect the contents in the driver's presence. If damage is detected:

1. Have the driver note the nature and extent of the damage on the freight bill.
2. Notify the transportation company's office to request an inspection. Carrier claim policies usually require inspections to be made within 15 days of delivery.
3. If damage is noticed, file a claim with the transportation company.

FILING A CLAIM

File a claim for loss at once with the transportation company for:

A. A cash adjustment; B. Repairs; or C. Replacement

When filing your claim, retain all packaging materials and receipts.

HANDLING THE CABINET

NOTE: *The refrigeration system of the cabinet is designed to operate with the cabinet located on a level surface. **Do not tilt the cabinet more than 10° to any side.** If the cabinet must be tilted on an angle for handling or moving purposes, allow it to sit in an upright position 30 minutes prior to starting.*

CHOOSING A LOCATION

This model cabinet should be situated to allow proper air circulation. Cabinets require a 2" minimum clearance behind for proper air circulation.

The cabinet must be installed on a sturdy, solid, level floor.

The cabinet must be located so it can be plugged or wired into a properly grounded three-prong electrical outlet of 115/220 volt, 60 hz. The electrical outlet should not be controlled by a wall switch which might be turned off accidentally.

UNCRATING THE CABINET

The cabinet should be moved as close as possible to the operating location before removing crate base. Be sure to follow the steps in the "INSPECTING FOR DAMAGES" instructions.

INSTALLING THE CABINET

After removing the skid from the cabinet, slide cabinet into location. **Level cabinet** to insure proper draining of the defrost water.

To meet NSF requirements, these cabinets must be sealed to the floor with an NSF or FDA approved sealant.

Remove the front grill from cabinet. Remove front hold down bolts and pull unit out of cabinet. Remove shipping band from compressor. Be sure that the compressor "floats" freely on the compressor springs. Check refrigeration lines to see that they are "free" and no damage was done in shipping. Check fan blade for free operation.

Check voltage and amp draw on the serial plate to determine proper fuse and line size. Voltage should be checked at the compressor terminals as the compressor is starting, to determine if there is excessive "voltage drop." This voltage drop should not exceed 10% of the rated compressor voltage. If the voltage reads 115 or 230 with no load and it drops below 103 or 208 when the compressor tries to start, it is an indication that the supply wiring is too small in size or too long in length.

It is recommended that a separate circuit be run for each cabinet to prevent the possibility of another appliance blowing a fuse causing subsequent loss of product.

CLEANING INSTRUCTIONS

CLEANING THE CABINET EXTERIOR

Wipe the exterior occasionally with a cloth dampened in mild detergent water; rinse, and wipe dry with a soft, dry cloth. Do not use abrasive or caustic cleaners or scouring pads.

CLEANING THE CONDENSER

Periodic cleaning of the condenser can be easily accomplished by brushing the coils with a soft brush and/or using a vacuum cleaner with a brush attachment.

Be sure that dirt, dust, and a collection of other debris do not build up to a point that air circulation through the condenser is restricted.

CLEANING THE STORAGE COMPARTMENT

1. Remove product and store it in another suitable cabinet, if possible. Be sure to prevent spoilage of the product which may occur if it is left at room temperature.
2. Turn OFF the thermostat and unplug the cabinet.
3. Defrost completely prior to cleaning.
4. Wash the entire interior storage area with warm water and baking soda solution — about a tablespoon of baking soda per quart of water. Rinse thoroughly with clean water and wipe dry.
5. A drain hose is provided. Connections are made to fit a standard garden hose for ease of draining water from inside of the tank area.

IMPORTANT:

Do not use any objects or cleaners which may leave residues, odors, or particles. Avoid the use of strong chemicals or abrasive cleaners which may damage the interior surfaces and contaminate product within the storage area.

6. Be sure to correctly plug in to cabinet, set the temperature control, and allow time for cooling of the storage area before storing product.

DESCRIPTION OF REFRIGERATION SYSTEM: CONDENSING UNIT

All CMCT cabinets are equipped with Copelametic compressors utilizing 404A refrigerant:

1/2 HP on the CMCT-4 and CMCT-6

3/4 HP on the CMCT-8

1 HP on the CMCT-10

A back pressure valve is used to protect the compressor against excessive pressures during initial cabinet start-up and upon termination of the defrost cycle. This valve is factory pre-set to limit the crankcase pressure to 10# and should not be changed.

CABINET OPERATION

REFRIGERATION CYCLE:

Refrigeration is accomplished by both a “wrap-around” tank coil and fin coil. This tank coil consists of several passes of copper tubing wrapped completely around the tank or product compartment. The fin coil located behind the light fixture serves two purposes — it creates a blanket of cold air over the product and collects moisture in the form of frost from the warm air entering the cabinet, thus reducing frost collection on the tank coil. The refrigerant enters the top of the tank coil first and progresses downward to the bottom of the tank; from there it enters the top of the fin coil and again downward. By circuiting the refrigeration in this manner, it assures the fin coil of being the coldest part of the system.

DEFROST CYCLE:

Because of the large size and fin arrangement, the CMCT fin coils have the ability to collect a large amount of frost before becoming blocked. These features permit the CMCT cabinets to operate on one defrost cycle per 24 hours, thus reducing product shock to the ice cream.

The fin coil and drain pan are defrosted with **one** 4-pass heater located on the underside of the evaporator assembly. The back pass of the heater lays in the drain trough which slopes from left to right along the back edge of the drain pan.

WARNING:

To avoid the possibility of an electrical shock, turn OFF thermostat and unplug the electrical cord of the cabinet before cleaning or touching electrical connections or parts.

Defrosting is initiated by the time clock and terminated by a temperature thermostat set to close at 76°F. When this thermostat closes, it energizes a solenoid in the time clock which in turn trips the clock mechanism off defrost. Should this thermostat fail to close, the defrost cycle will be terminated by the failsafe pin on the time clock (set at 40 minutes).

As an additional safety feature, the temperature limiting thermostat is wired in series with the defrost heater. This thermostat will also open the heater circuit when the top coil reaches 76°F. should any malfunction of the defrost thermostat occur.

NOTE: *Any time the system has been opened and exposed to the atmosphere, a new drier should be installed, system completely evacuated, and recharged to the specified refrigerant and amount listed on the serial plate located inside the unit compartment on the left wall.*

IMPORTANT: **DO NOT ATTEMPT CHARGING BY PRESSURES ALONE!!** Charge is very critical! Charging should be accomplished by means of weighing, or the use of a charging cylinder.

CMCT ELECTRICAL DATA

CMCT-4	OHMS	WATTS	AMPS	VOLTS
Def. Heater on Bottom side of Top Coil	24.7	582	4.8	120
Control Bellows Heater below Def. Controls	1600	9	.075	120
End Breaker Heater behind each End Breaker	960	15	.12	120
Glass Heater around Front Glass	262	56	.46	120

CMCT-8	OHMS	WATTS	AMPS	VOLTS
Def. Heater on Bottom side of Top Coil	11.8	1200	10	120
Control Bellows Heater below Def. Controls	1600	9	.075	120
End Breaker Heater behind each End Breaker	960	15	.12	120
Glass Heater around Front Glass	134	107	.89	120

CMCT-6	OHMS	WATTS	AMPS	VOLTS
Def. Heater on Bottom side of Top Coil	15.9	904	7.5	120
Control Bellows Heater below Def. Controls	1600	9	.075	120
End Breaker Heater behind each End Breaker	960	15	.12	120
Glass Heater around Front Glass	175	82	.68	120

CMCT-10	OHMS	WATTS	AMPS	VOLTS
Def. Heater on Bottom side of Top Coil	3.38	1561	6.7	230
Control Bellows Heater below Def. Controls	1600	9	.075	120
End Breaker Heater behind each End Breaker	960	15	.12	120
Glass Heater around Front Glass	190	132	1.1	120

REFRIGERATION/ELECTRICAL SPECIFICATIONS CMCT (404A)

CABINET MODEL	MFG.	MODEL	HP	VOLTS	START AMPS	RUN AMPS
CMCT-4	Copeland	KAGB-005E-IAA-222	1/2	115	45	8.0
CMCT-6	Copeland	KAGB-005E-IAA-222	1/2	115	45	8.0
CMCT-8	Copeland	KAJB-007E-IAA-222	3/4	115	59	12.0
CMCT-10	Copeland	KALB-010E-CAV-221	1	230/208	33.5	8.1

REFRIGERATION CYCLE (80° Ambient)

CABINET MODEL	REFRIG. CYCLE	DEFROST CYCLE	REFRIG.	OZ.	CAP. TUBE	SUCT.	DISCH.	CONTROL SETTING	CAVITY TEMP.
CMCT-4	8.0 - 115V	6.8 - 115V	404A	22	8' x .042 ID	2#	225#	No. 7	-22°F
CMCT-6	8.0 - 115V	8.4 - 115V	404A	23	8' x .042 ID	5#	223#	No. 7	-19°F
CMCT-8	12.0 - 115V	12.0 - 115V	404A	27	7' x .049 ID	2#	228#	No. 7	-22°F
CMCT-10	8.1 - 230V 4.8 - 115V	6.7 - 230V 4.8 - 115V	404A	29	7' x .054 ID	2#	223#	No. 7	-27°F

NOTE: Refer to Data plate for refrigerant type and charge.

Condenser FanG.E. 5KSM51GG37845 or
5KPM51BL-40466 (Reversible Motor)
230 - V.E.M.S. ESP-L35-EM2

Time Clock115 Paragon 145-00B (24 Hr.)
230V Paragon 145-20B (24 Hr.)

Temperature ControlRANCO A10-4491-00

Back Pressure ValveSporlan 10# setting
CRO-4-0-20
CRO-6-0-60 (CMCT-10)

ECMCT REFRIGERATION/ELECTRICAL DATA

Export Models (R-404A)

ECMCT-4	OHMS	WATTS	AMPS	VOLTS
Def. Heater on Bottom side of Top Coil	72.4	582	2.7	215
Control Bellows Heater below Def. Controls	5375	9	.04	215
End Breaker Heater behind each End Breaker	3071.4	15	.07	215
Glass Heater around Front Glass	826.9	56	.26	215
Heated Glass Lid (each)	41.3	14	.58	24

ECMCT-6	OHMS	WATTS	AMPS	VOLTS
Def. Heater on Bottom side of Top Coil	51	904	4.2	215
Control Bellows Heater below Def. Controls	5375	9	.04	215
End Breaker Heater behind each End Breaker	3071.4	15	.07	215
Glass Heater around Front Glass	565.8	82	.38	215
Heated Glass Lid (each)	26.1	22	.92	24

COMPRESSOR AMPERAGE

CABINET MODEL	MFG.	MODEL	HP	VOLTS	LRA	RUN AMPS	OZ.	CAP. TUBE
ECMCT-4	Copeland	KAJB-010E-CAV	1	200	40	8.0	20	8' x .042
ECMCT-6	Copeland	KAJB-010E-CAV	1	200	40	8.0	25	8' x .042

LAMP WIRING DETAIL - Upper Raceway (Typical)

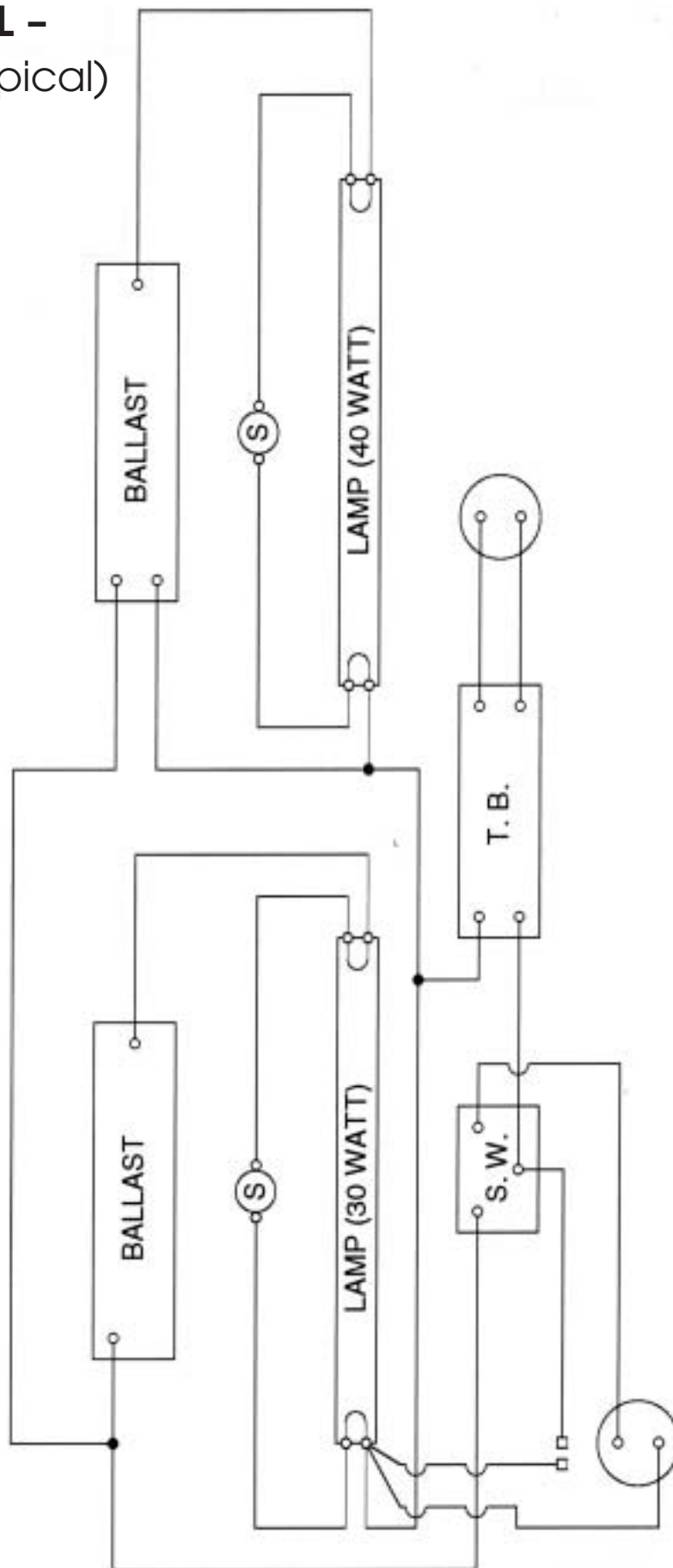

SECTION II

Maintenance & Repair

CABINET TEMPERATURE CONTROL

CAUTION: Disconnect the power supply before servicing the cabinet.

Remove the front grill.

The control is located in the machine compartment in the upper righthand corner, just above the electrical box. Control settings are numbered from #1 (warmest) to #7 (coldest) positions.

The control capillary is inserted in a copper bulb well just to the right of the control. The well is approximately 20" long and is secured to the cold wall evaporator. The control reacts to the evaporator temperature which is approximately -40°F in order to maintain a cavity temperature of -20°F.

COLD OUT	NORMAL OUT	NORMAL IN	WARM IN
-30°F	-23°F	-15°F	-2°F
TERMINALS: .25 QUICK CONNECT TAB			
CAP TUBE LENGTH: 24"			

1. Temperature Control
2. 115V Cabinet Power Switch (115V models)
3. 230V Cabinet Power Switch (230V models)

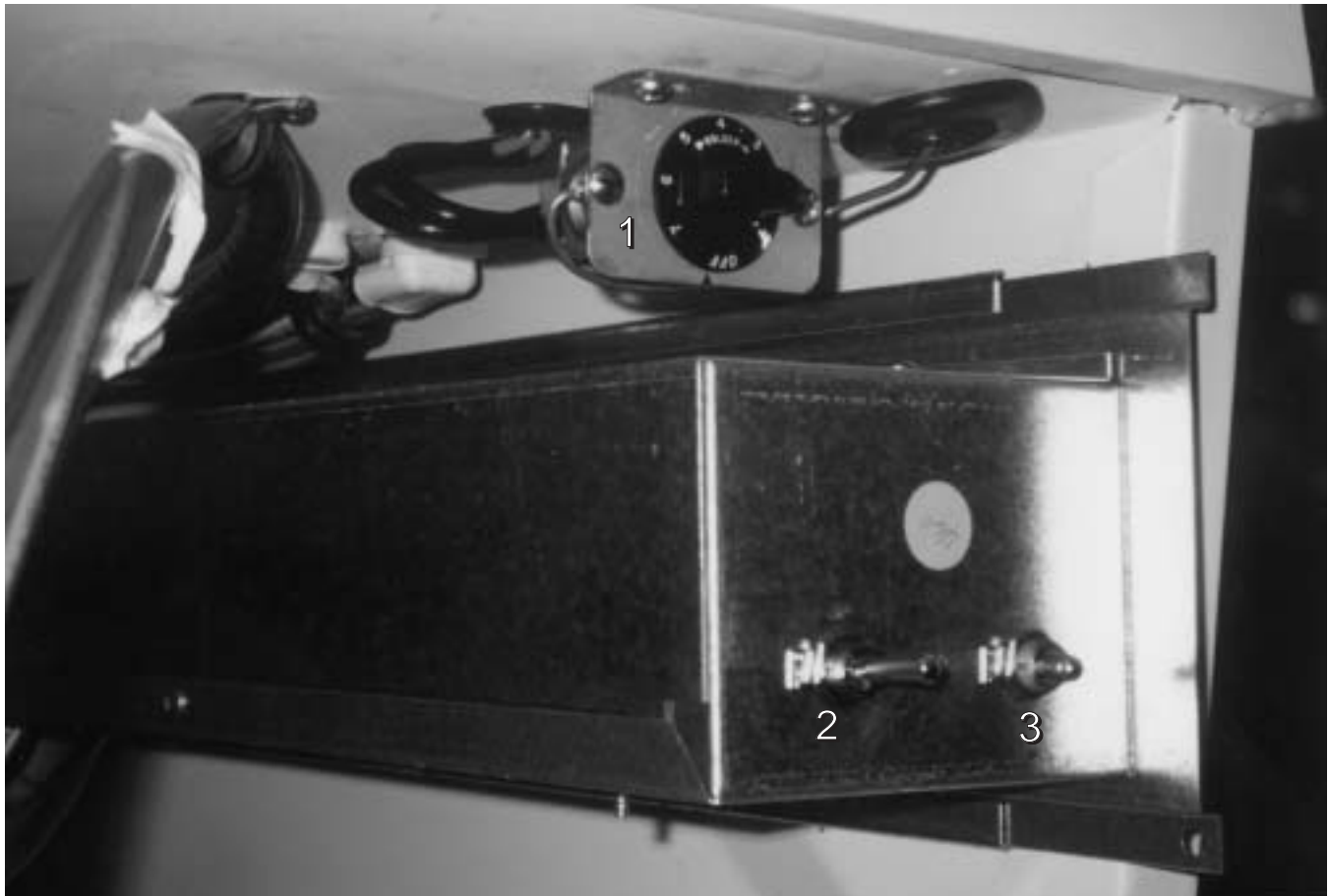

ELECTRICAL BOX LAYOUT

CAUTION: Disconnect the power supply before servicing the cabinet.

The electrical box can be accessed by removing the front grill.

The electrical box can be pulled out for component troubleshooting.

The following components are located within the box.

- | | |
|--------------------------------------|--|
| 1. Defrost Timer - 1/24 Hours | 5. Main Terminal Board |
| 2. Run Capacitor | 6. 115V Power Supply Switch (115V models) |
| 3. Start Capacitor | 7. 230V Power Supply Switch (230V models) |
| 4. Potential Relay | |

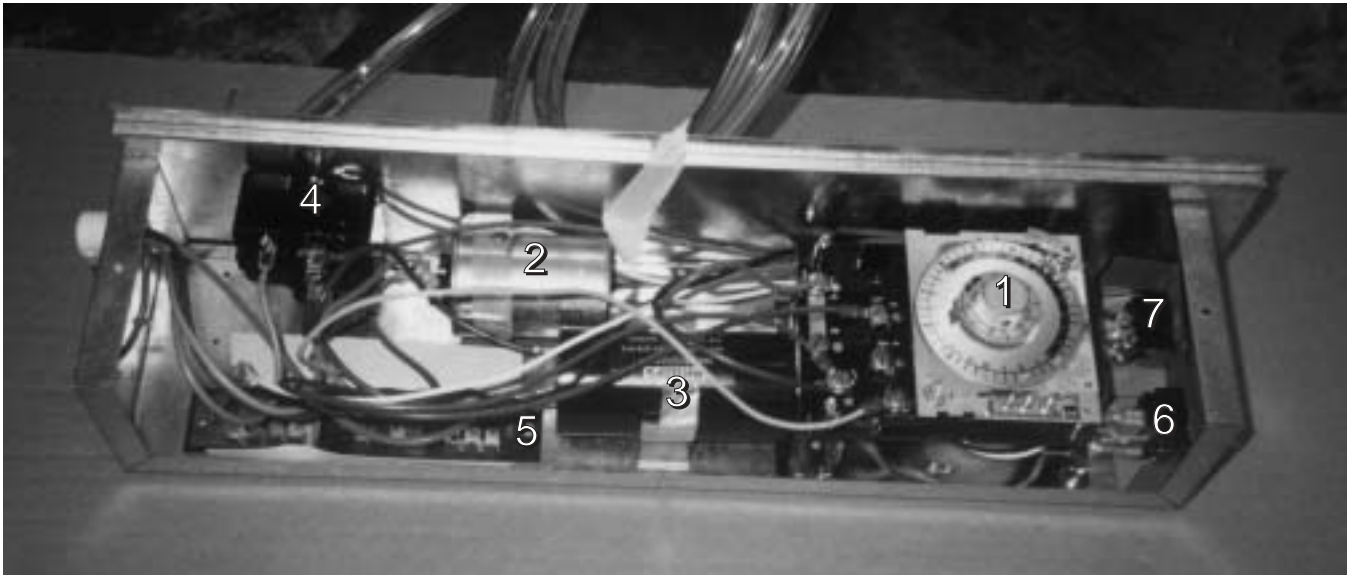

DEFROST TIMER LAYOUT

After the cabinet is connected to proper voltage supply, the time clock should be set to the correct time of day by turning the inner knob counterclockwise until the correct time is opposite the time indicator on the clock. The time clock is set to go into defrost **once** every 24 hours. This defrost occurs at midnight. Under extreme humidity conditions it might be necessary to add a second defrost.

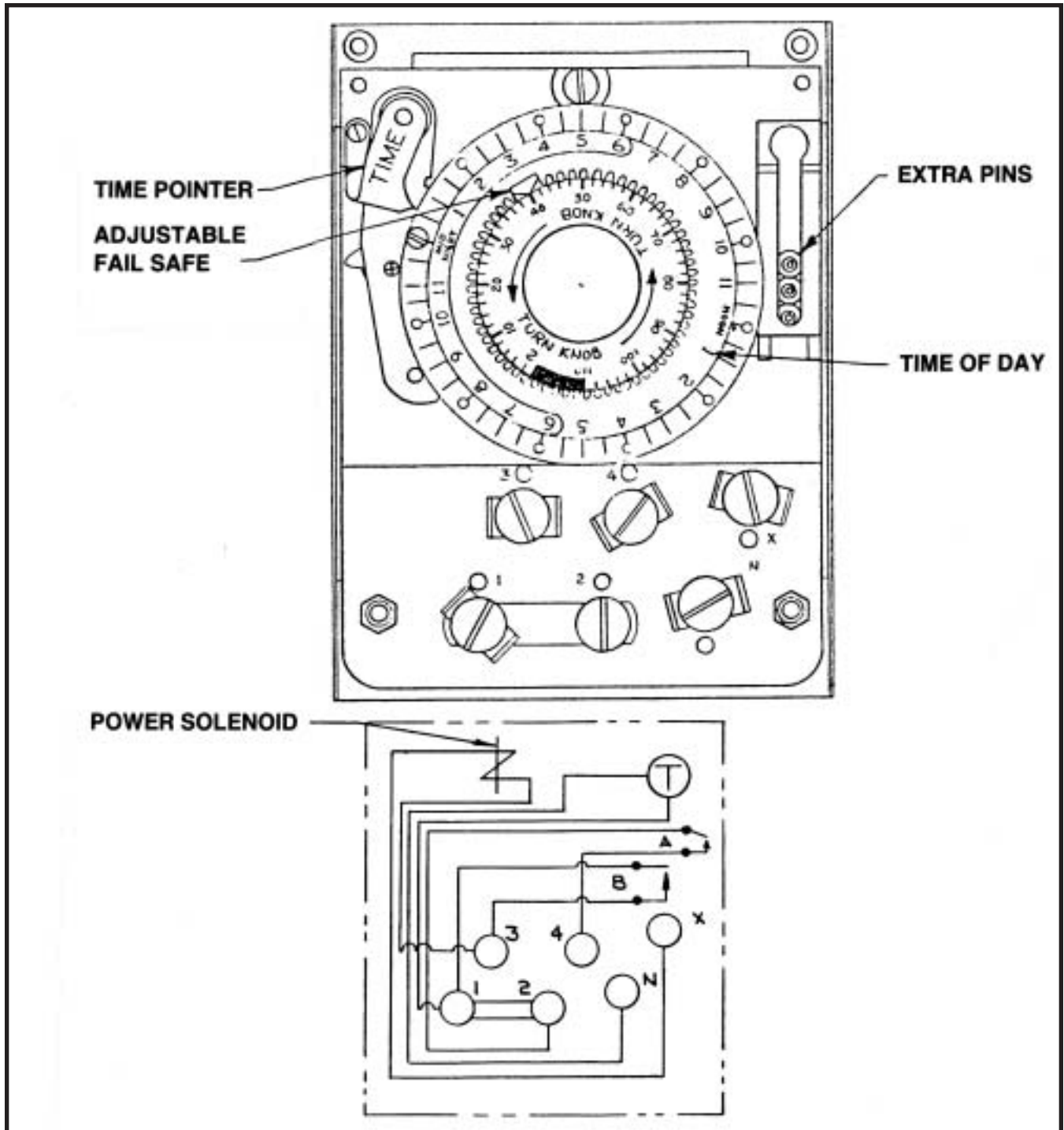

CABINET ELECTRICAL SUPPLY

The connection points can be accessed by removing the rear grill. Models CMCT-4 up through CMCT-8 have 115V service cords. CMCT-10 is 230V, hard wire connected.

NOTE: *These cabinets must be on a dedicated circuit unto themselves. Failure to do so could result in loss of product.*

IMPORTANT: Wiring and connections in power supply system must meet all applicable (local and national) electrical codes. Consult these codes for wire lengths and sizes prior to cabinet installation.

The wiring diagram should be consulted before attempting any electrical service.

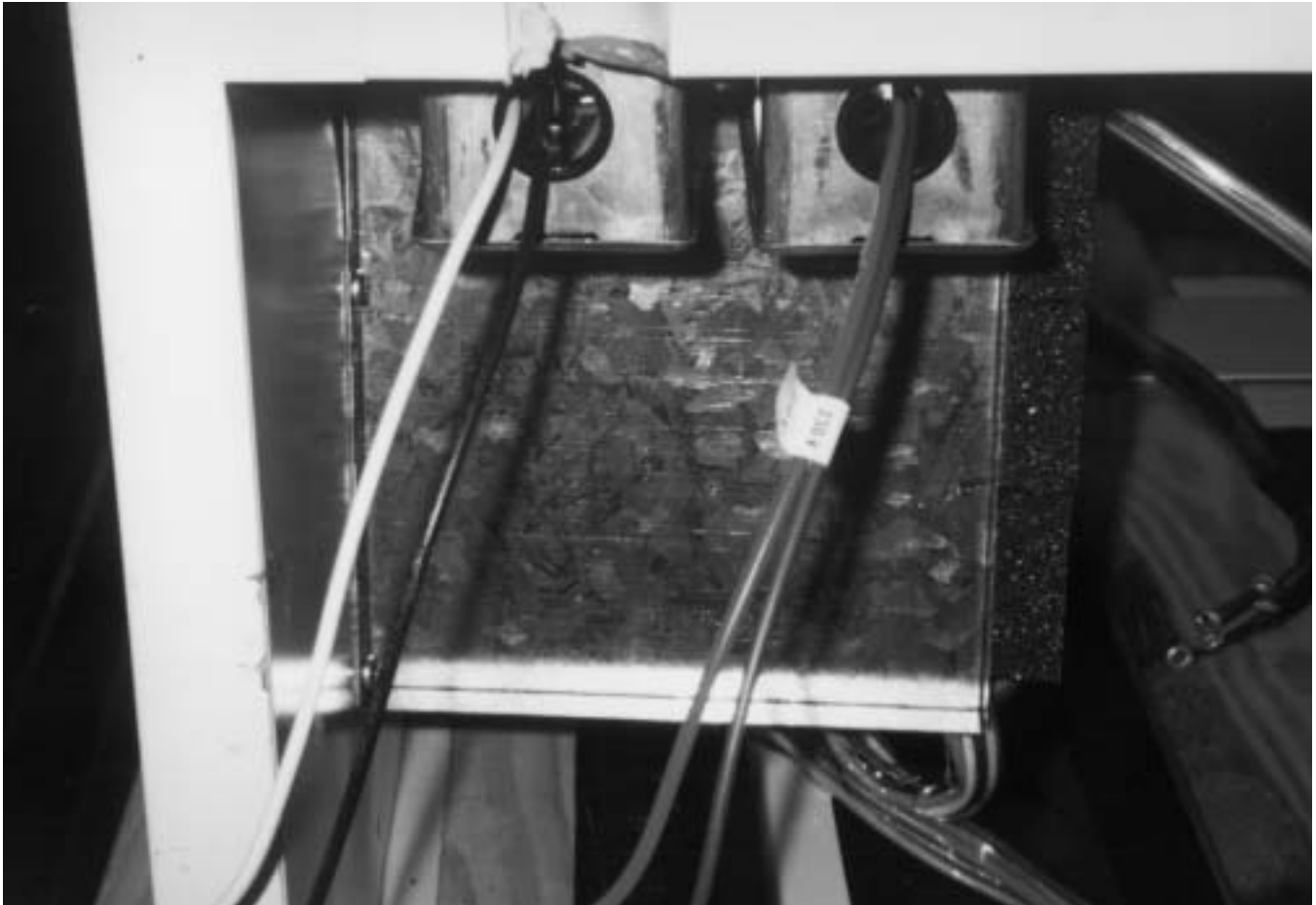

CONDENSING UNIT ASSEMBLY

This product utilizes the pull out feature on its low temperature applications. This is to aid service personnel in the event service is needed.

CAUTION: *Disconnect the power supply before servicing the cabinet.*

1. Remove front grill.
2. Remove two (2) hold down bolts that are located in the front base rail. Pull unit out for service.



UNIT COMPARTMENT – REAR

NOTE: *CMCT-10 models still use fin and tube condensers.*



1. Accordion Coil
2. Process Tube Evaporator
3. Suction Line
4. Cap Tube Inlet

EVAPORATOR TUBING ILLUSTRATION

EVAPORATOR TANK WRAP - RH SIDE VIEW:

NOTE: *Evaporator inlet tube on top row.*

1. Tank Wrap Inlet
2. #2 Pass
3. #3 Pass
4. Thermostat Bulb Well
5. Condensate Drain

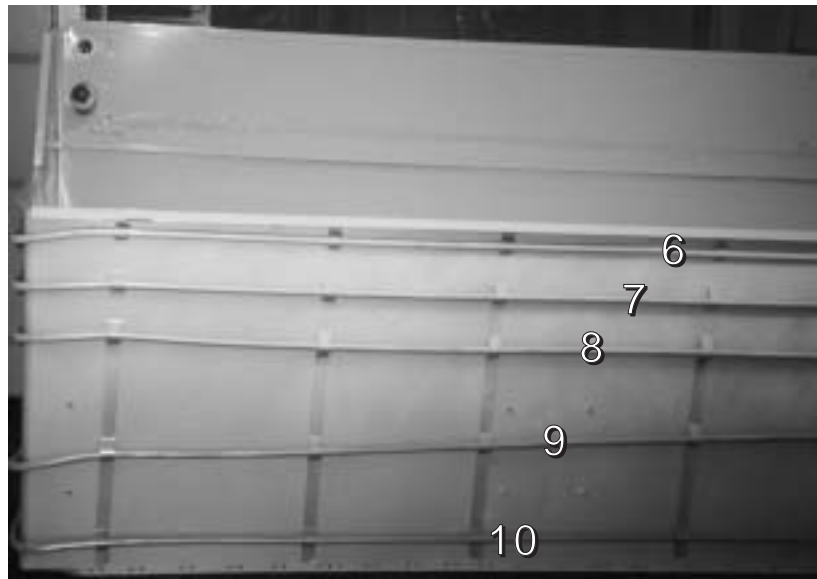
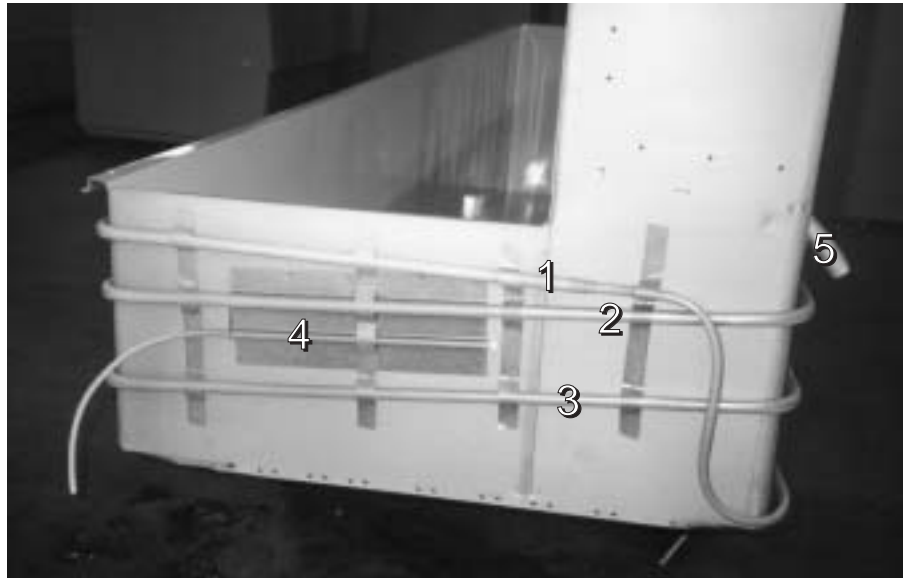

TANK WRAP - FRONT SIDE

6. #1 Pass
7. #2 Pass
8. #3 Pass
9. #4 Pass
10. #5 Pass

NOTE: *Upper evaporator coil connections are on the top, left back wall.*

EVAPORATOR TANK WRAP - RIGHTHAND REAR OF CABINET:

Capillary tube and heat exchange are foamed in place. Three lines exit the cabinet shell:

11. 1/4" Process Line
12. Capillary Tube
13. Suction Line

If the capillary tube should ever become restricted, the 1/4" process tube can be substituted as an evaporator inlet.

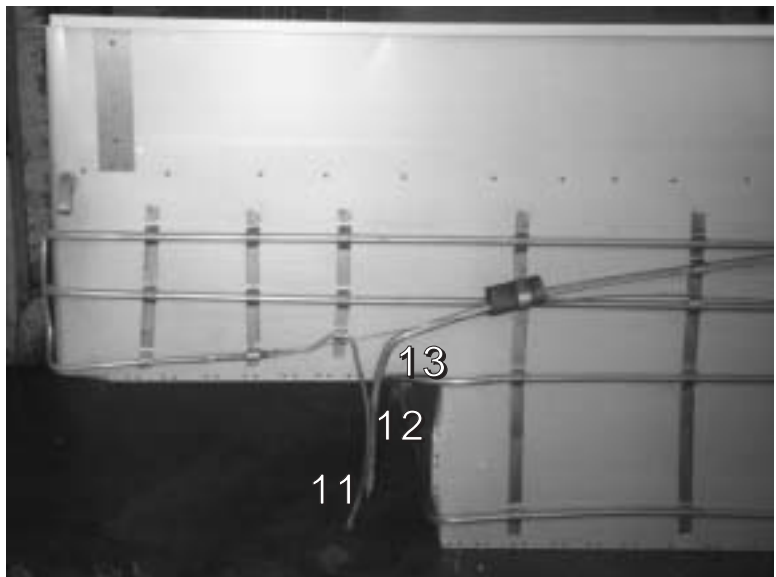

NEW LUBRICANTS

In switching from refrigerant 502 to refrigerant 404A, the compressor lubricants had to be changed. Oils used in the compressors in the past were mineral based. The new oils used are polyol esters. Special consideration must be made when handling these oils. Processing procedures must be more rigorous to avoid absorbing moisture. Also, P.O.E.'s are better solvents which means they will dislodge and carry debris through a system to a far greater extent than do mineral oils. The oil used in Copeland compressor is Mobil Artic EAL-22-CC.

BACK PRESSURE VALVE – #1

These models are equipped with a back pressure valve. The purpose of this valve is to limit the suction pressure at the compressor during initial cabinet start up and start up after a defrost cycle. This valve is set at 10 PSIG and **should not be changed**. To check this setting it is necessary that the pressure on the inlet side or evaporator side of the valve be above 10 PSIG. Put cabinet into defrost cycle to obtain high-low side pressure. With gauge installed on suction service valve, check valve setting after cabinet comes off the defrost cycle. Allow the compressor to run a few minutes before determining correct setting. (CRO6 shown)



LIGHT CHANNEL ASSEMBLY – Component Identification

CAUTION: Disconnect the power supply before servicing the cabinet.

Wiring from the pull out electrical box is connected via a wiring harness to the upper lighting channel which houses the following components:

- | | |
|---------------------------------------|---|
| 1. Product Reflector | 4. Light Ballast |
| 2. Defrost Termination Control | 5. Lamp Receptacle & Starter |
| 3. Upper Terminal Board | 6. Ambient Temperature Compensator |

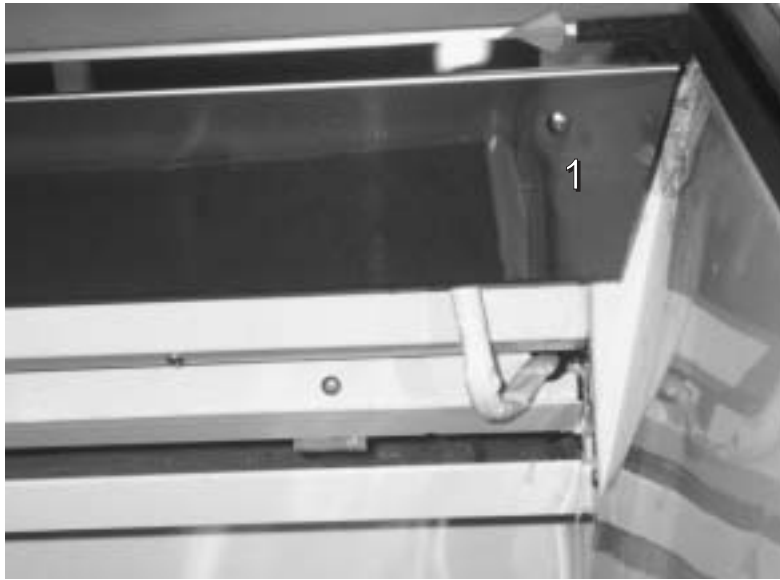

BAFFLE HEATER COMPONENT IDENTIFICATION & REMOVAL INSTRUCTIONS

1. Baffle Heater
2. Light Switch
3. Light Receptacle – Lefthand side

NOTE: *When light switch is ON, baffle heater is de-energized.*

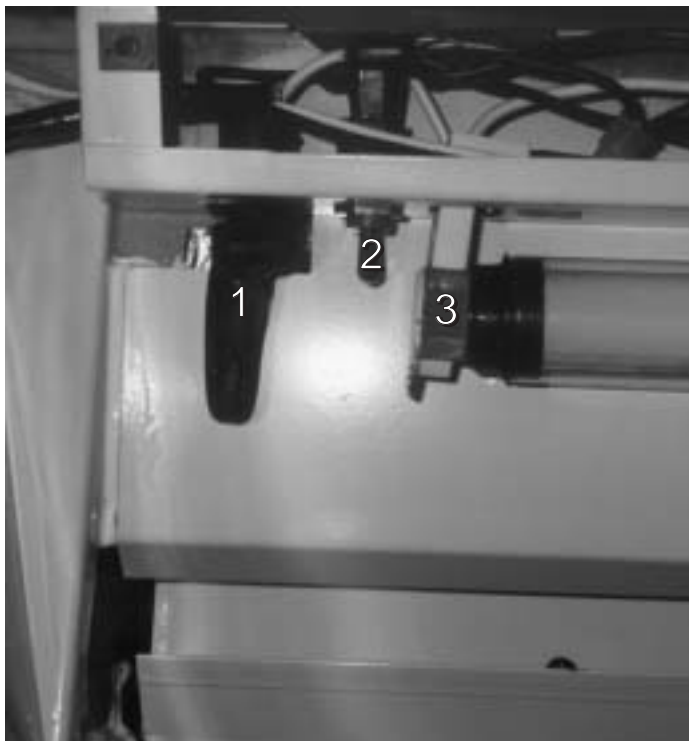

CAUTION: Disconnect the power supply before servicing the cabinet.

The baffle heater is located just behind the light fixture at the warm air intake to coil.

The baffle can be accessed by removing screws located at the bottom edge of V baffle. The heater is attached at the back side of the V baffle with self-adhesive tape.

The heater resistance can be checked by unplugging the heater at the plug-in connector on the lefthand end of the light channel. The heater is only energized when the light is turned OFF.

END PANEL BREAKER & HEATER REMOVAL

CAUTION: Disconnect the power supply before servicing the cabinet.

1. Remove eight (8) screws in the end panel breaker (A) and pull breaker down and out.
2. Disconnect heater leads from end panel breaker heater (A) and pull end panel breaker out.
3. To remove end panel breaker heater, remove tape.



NOTE: *The heater is taped to the back side of the side arm breaker.*

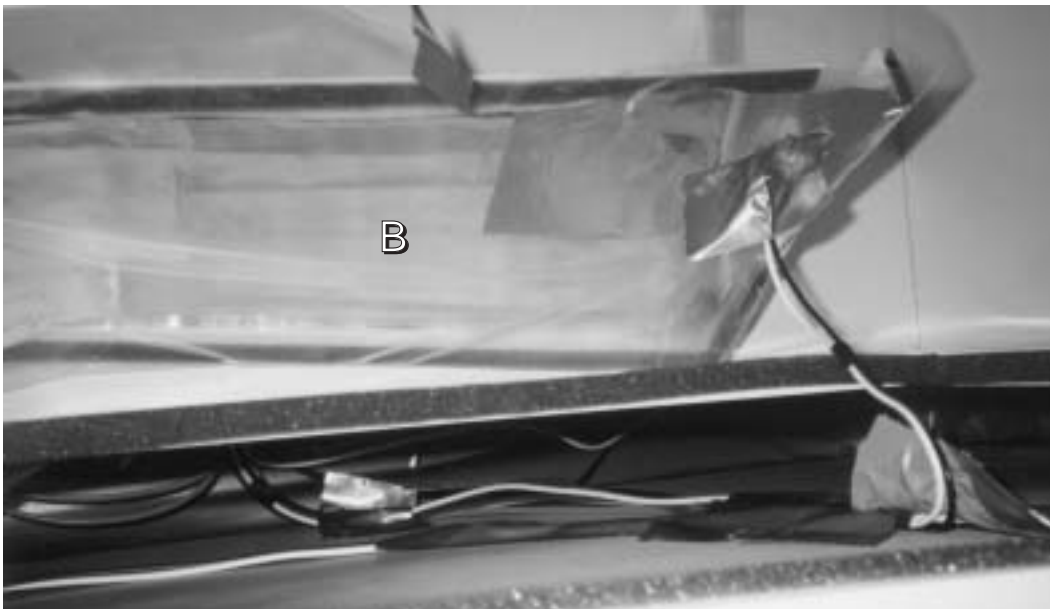

REFRIGERATED UPPER SECTION COMPONENT IDENTIFICATION & REMOVAL INSTRUCTIONS

- 1. Defrost Heater Lead Connection
- 2. Air Baffle
- 3. Upper Fin Coil
- 4. Defrost Heater
- 5. Defrost Heater Retainer Bracket
- 6. Front Coil Housing Cover Bracket

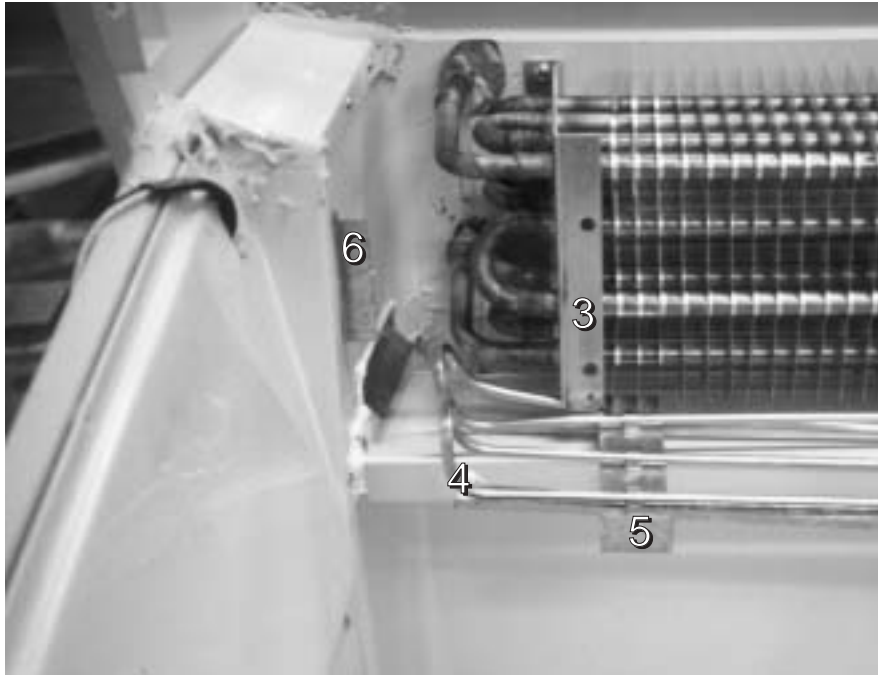

REMOVAL INSTRUCTIONS:

CAUTION: Disconnect the power supply before servicing the cabinet.

1. Disconnect the defrost heater leads located on the lower right-hand side of the lamp channel – Figure #1.
2. Remove the air diverter shown as Figure #2. This will expose the defrost heater rack which is mounted to the evaporator fin coil. Heater and rack assembly can now be removed.
3. Reattach new heater to rack. NOTE: Last pass of the defrost heater must lay down in the drain trough.
4. Reassemble in reverse order.

UPPER CROSS SECTION - CMCT Models

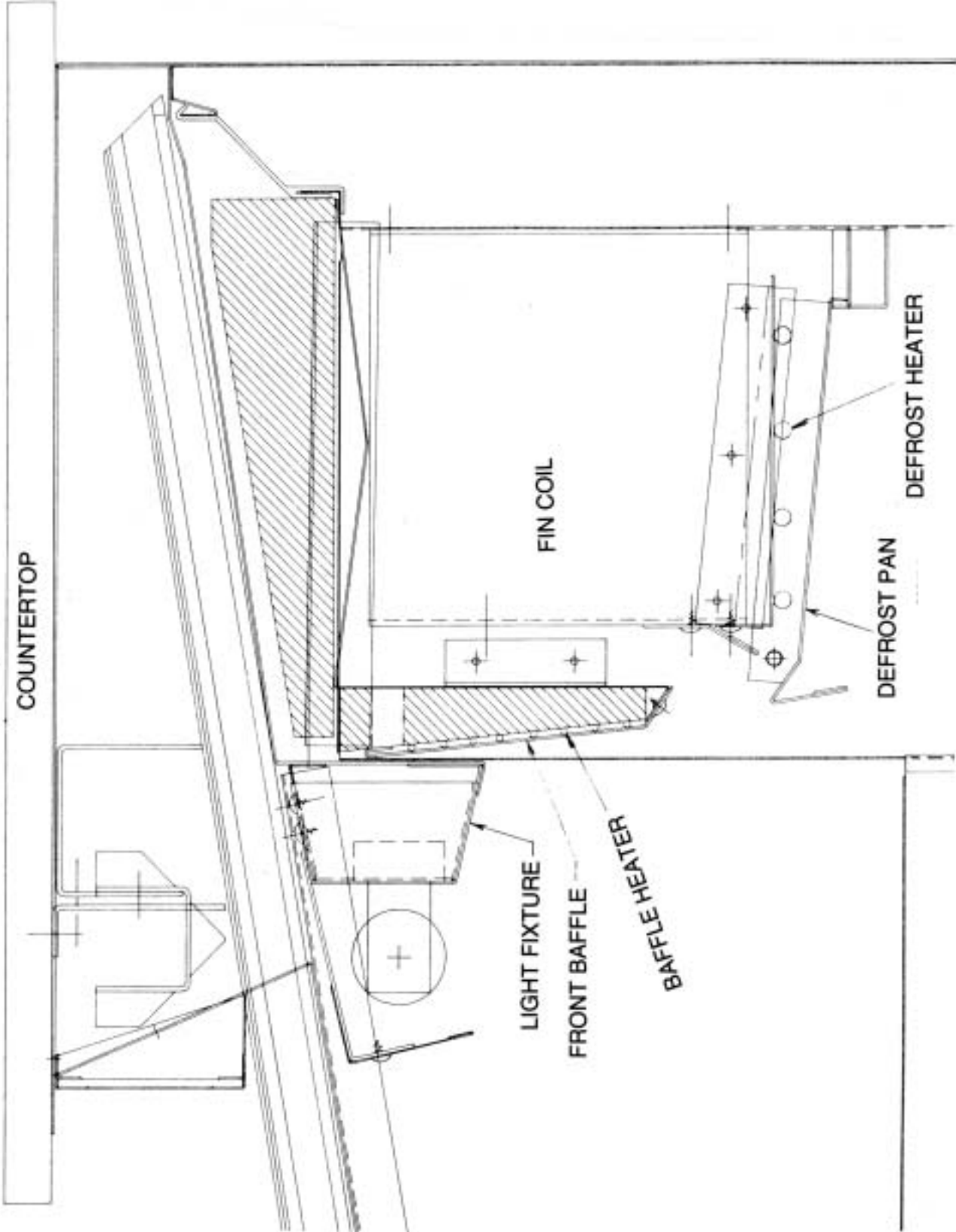

FRONT GLASS HEATER REPLACEMENT

CAUTION: Disconnect the power supply before servicing the cabinet.

Photograph shows the electrical connection between the cabinet and the front glass heater.

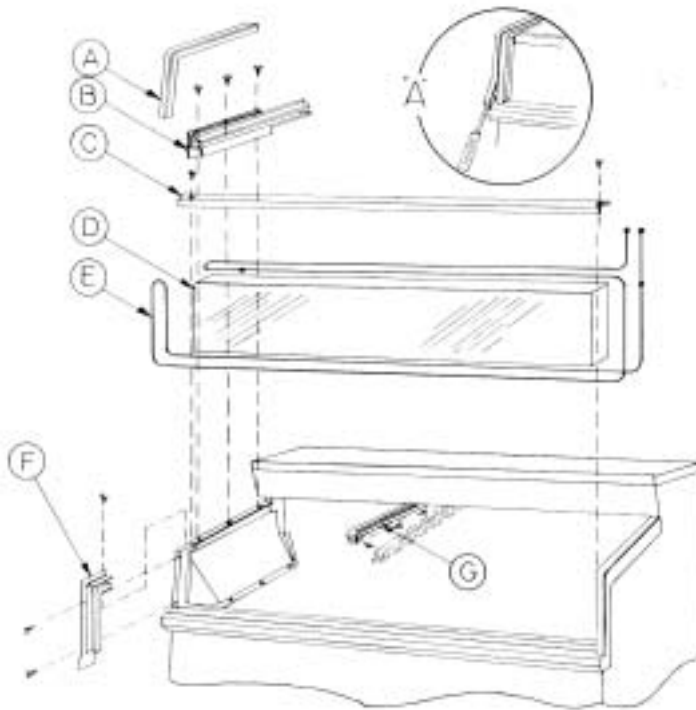

REMOVAL OF FRONT GLASS HEATER AND/OR END TRACK:

1. Remove glass lids.
2. Remove side arm trim (A) at both sides per detail 'A'.
3. Remove three (3) screws in vertical trim post (F) and pull vertical trim post forward. Typical at both ends.
4. Remove three (3) screws in end track (B). Pull track forward and lift up. Typical both ends. (Not necessary for glass removal.)
5. Remove two (2) screws in the front of center track (G) and swing center track from dotted line position to solid line position.
6. Remove two (2) screws (one each end) on glass rail (C) and lift glass rail straight up.
7. Pull top of front glass (D) forward and lift glass and heater (E) up.
8. To remove end track only, execute the first four steps. To remove front glass heater, execute the first seven steps, omitting step number 4.

NOTE: Pay close attention to the way the heater wire is arranged on the front glass when replacing.

CMCT Models

The countertop can be raised in order to service various interior components, as shown below.



- 1.** Product Reflector
- 2.** Defrost Heater Plug
- 3.** Lamp

- 4.** Upper Electrical Component Housing
- 5.** Righthand Arm Heater Leads

EVAPORATOR COIL REMOVAL

CAUTION: Disconnect the power supply before servicing the cabinet.

- A. Raise up the counter top.
- B. Remove screws along the back wall of the sub top.
- C. Remove the high air intake baffle located on the righthand side of the sub top.
- D. Remove the cabinet lids and lid rails.
- E. Remove the screws that hold the light channel to the sub top.
- F. Pull the defrost termination bulb out of the evaporator coil bulb well. Lift the sub top up and out of the cabinet.

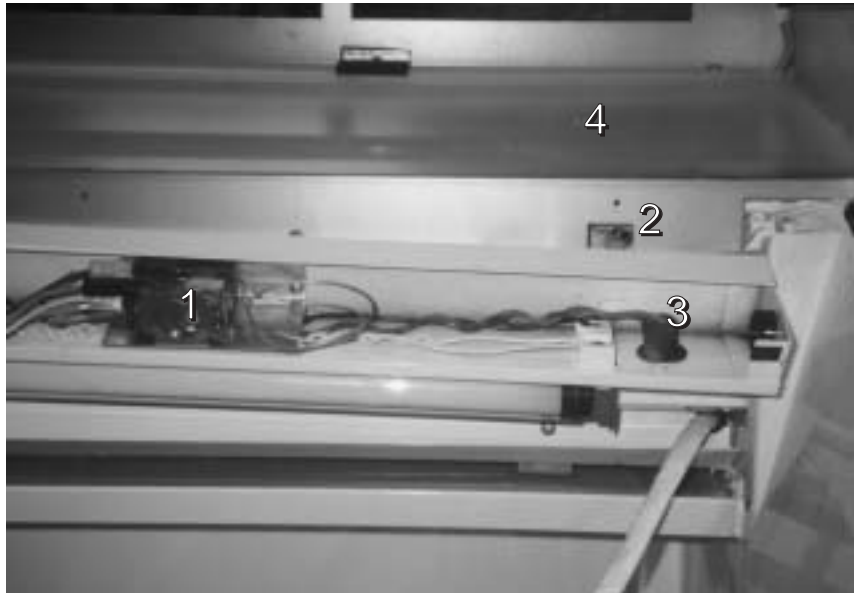

- 1. Defrost Termination & High Limit Control
- 2. Defrost Termination Bulb Well
- 3. Defrost Heater Receptacle
- 4. Sub Top



- G. Lift the insulation up and out of the cabinet. Do not break. This will expose the coil housing cover. This cover is attached by three screws, one on each end and one at the rear on the top.

- 5. Upper Coil Insulation
- 6. V Baffle Insulation
- 7. V Baffle Front

NOTE: Reseal bulb well and coil cover with permagum as shown.

- 8. Coil Cover
- 9. V Baffle Heater

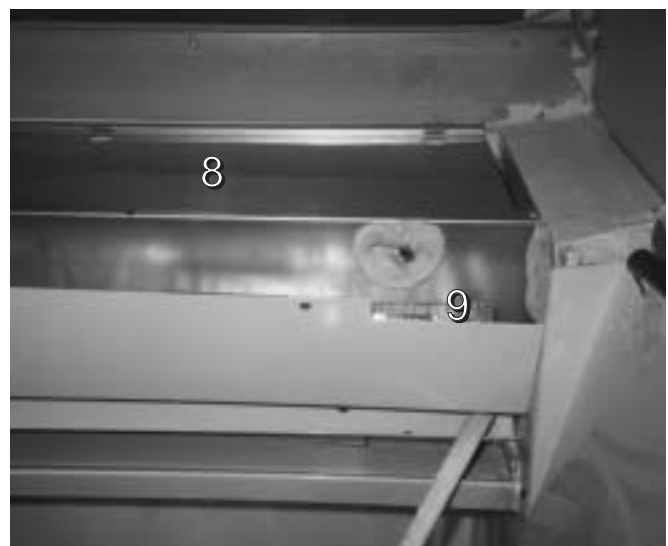

EVAPORATOR COIL REMOVAL – continued

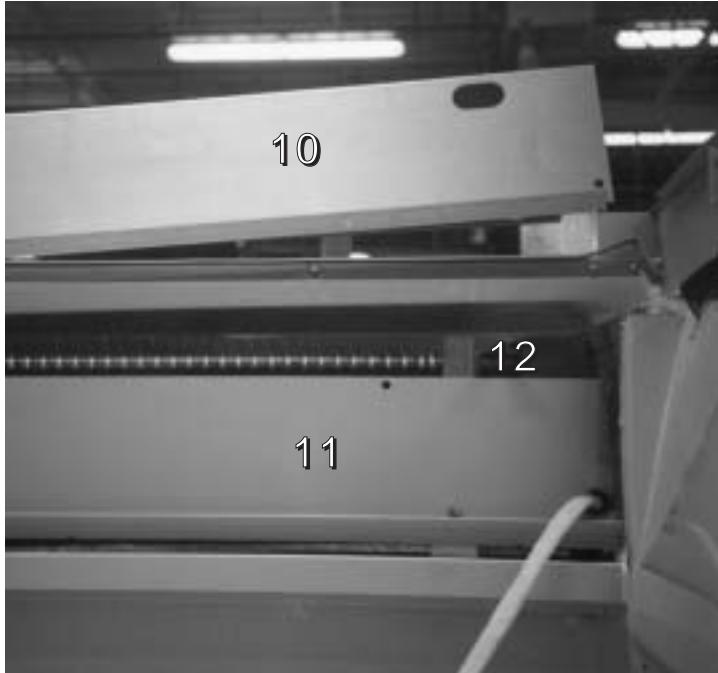

10. Sub Top

11. Air Diverter

12. Defrost Termination Bulb Well

The view below illustrates the evaporator coil and tube connections on the lefthand end of the cabinet. Take care when reinstalling the coil housing cover. Reseal areas where moisture could migrate down into the coil area. This coil area runs at a temperature of -40°F .

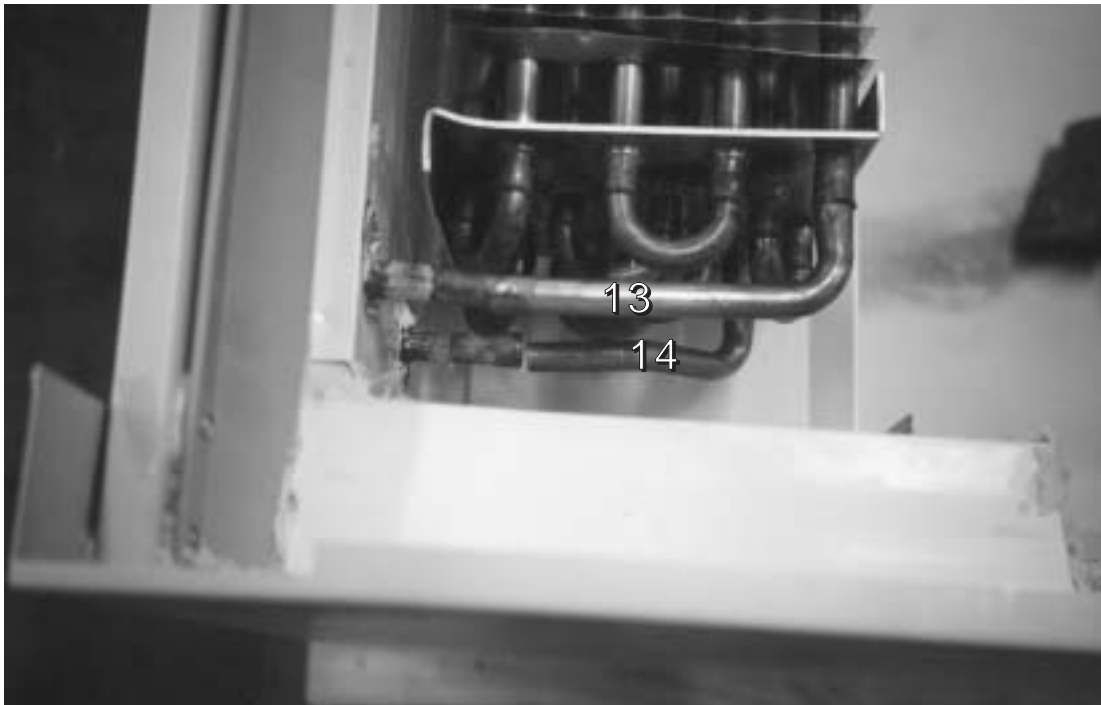

13. Upper Coil Inlet

14. Upper Coil Outlet

CMCT TROUBLESHOOTING GUIDE

The following is a guide to aid in the proper diagnosing of service problems.

High Head Pressure & High Back Pressure

1. Air in system.
2. Defective fan motor or fan blade dragging on condenser shroud.
3. Defrost heater on during refrigeration cycle due to heater going to ground or defective time clock.
4. Refrigerant over charge.
5. Blocked condenser (dirty)

Low Back Pressure & Low Head Pressure

1. Defective back pressure valve—check for proper setting as described under “Back Pressure Valve.”
2. Shortage of refrigerant—place a temperature indicating device on outlet of top coil (lower lefthand side of coil). Temperature should read within 3 to 4 degrees of low side pressure taken at the compressor suction service valve. Add gas slowly until these conditions are obtained or remove charge with certified recovery equipment, and recharge with correct charge.
3. Cap tube plugged due to moisture or dirt.

Pressures Normal - Cabinet Warm

1. Top coil blocked with frost—see corrective measures under “Coil Block With Frost.”
2. Refrigerant under charge. Due to the fact that it takes a considerable amount of under charge before it has any great effect on pressures and inaccuracy of gauges it is possible to have normal pressures and yet have an under charge of refrigerant. This under charge will “starve” the top coil and seriously affect cabinet temperature. To determine correct charge see #2 under “**Low Back Pressure ...**”

Coil Blocked With Frost

1. Bad timer or timer motor.
2. Bad drafts in store caused by heating or air conditioning fans; cabinet located too close to door.
3. Defective defrost heater.
4. Defective defrost terminating thermostat, safety thermostat or defective solenoid in time clock.

Either of these (#4) can keep the cabinet from going through a defrost cycle. The defrost thermostat (see wiring diagram) should be in open position between terminals 1 & 2 when the cabinet goes into defrost.

After the coil reaches 76°F, it closes, energizing a solenoid in the time clock which in turn trips the time clock mechanism off defrost. Should this thermostat be in the closed position when the clock trips into the defrost cycle, it will immediately trip it off again. (NOTE: Switch between terminals 1 & 2 will not open until thermostat drops below 59°F).

If the solenoid in the clock is stuck closed (plunger up), it will have the same effect. To determine which is at fault, remove the wire from X on the clock and turn clock dial into defrost cycle; if cabinet goes into defrost, it is the defrost thermostat that is bad. If it still does not go into defrost, remove clock and inspect the plunger of the solenoid coil.

5. Defective safety thermostat.

This thermostat has a SPDT switch with one side wired in series with the defrost heater. Contacts between terminals 2 & 3 should be in the closed position during the refrigeration cycle. Its only purpose is, in case of failure of the defrost timer during the defrost cycle, it will open the heater circuit when the coil reaches 76°F, preventing any over heating of the defrost heater.

If this thermostat is in the open position when the cabinet goes into the defrost cycle, the heater will remain off. For access to thermostat connections to check continuity, refer to wiring diagram. Disconnect this thermostat and check with ohmmeter.

If for any reason the temperature termination feature is inoperative, the fail safe settings on the timer should be set for 30 minutes defrost time.

Defrost Cycle Too Long - Terminating On Fail Safe (Heater On)

1. Bad solenoid in time clock (opening winding).

If there is an open circuit in the coil of this solenoid, it will not trip the time clock off defrost when the thermostat closes. The cabinet will stay on defrost for the length of time the fail-safe lever on the time clock is set. (Factory set at 40 minutes.)

2. Defrost terminating thermostat not closing when coil reaches 76°F.

To determine which is at fault, turn clock into defrost, place jumper across X and N on clock. If solenoid is good, this will trip the clock off defrost indicating that it is the defrost thermostat that is at fault.

NOTE: *Be certain that the defrost thermostat has reached 76°F before determining that either the solenoid coil or the thermostat is defective.*

SECTION III

Parts List

CABINET EXTERIOR PARTS IDENTIFICATION

CMCT Models

- | | | |
|-----------------------------------|-------------------------------------|-------------------------------------|
| 1. Vertical Trim Post (RH) | 6. Center Track | 11. Nameplate |
| 2. End Track (LH) | 7. Glass Lid | 12. Front Bumper |
| 3. Countertop | 8. Glass Rail | 13. Bumper Trim |
| 4. End Trim | 9. Front Glass | 14. Front Trim Panel – Upper |
| 5. Lighted Sign | 10. Front Trim Panel – Lower | 15. Front Grill |

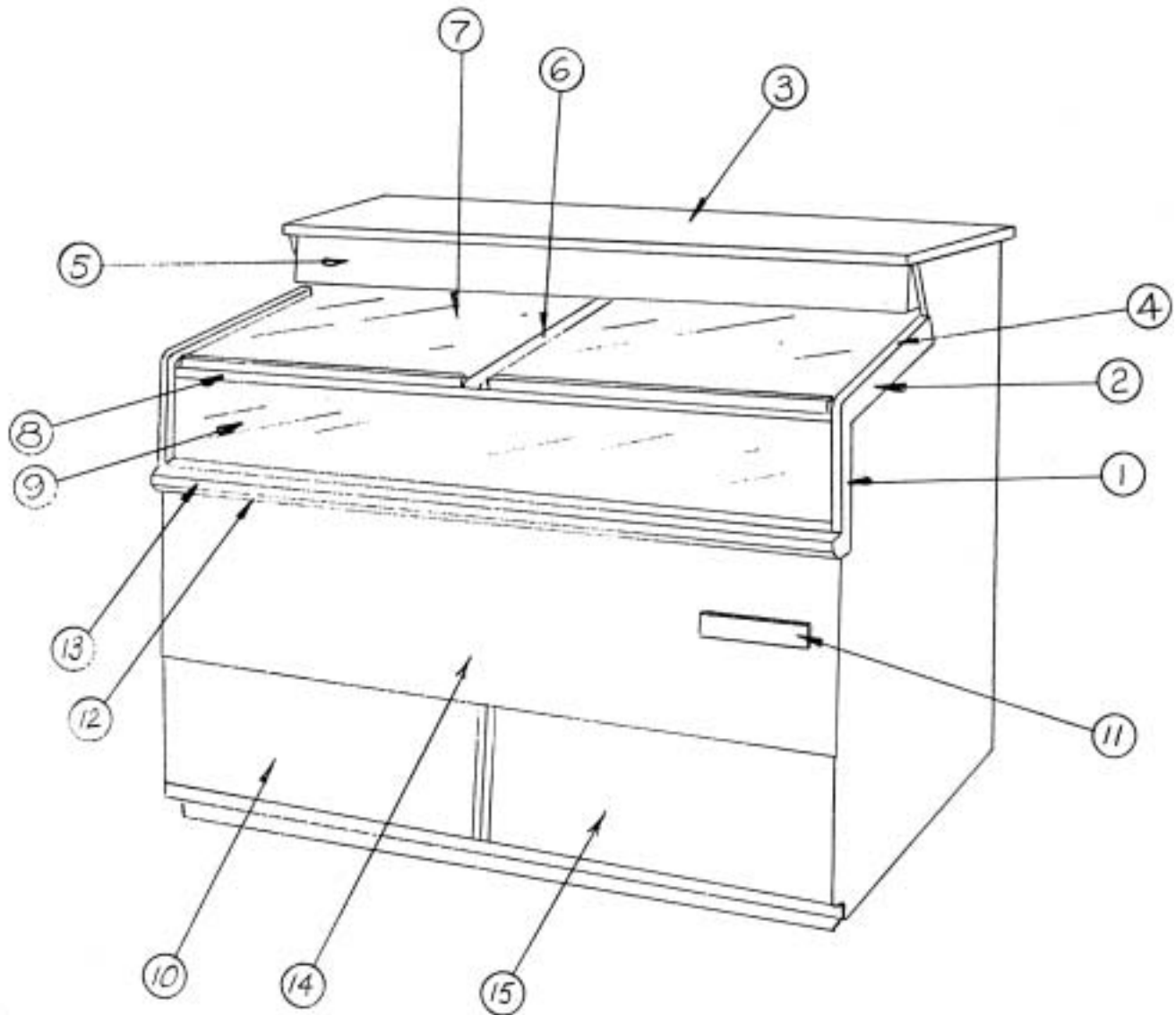

DOMESTIC CMCT PARTS LIST – R-404

Parts List - CMCT's				
Description	CMCT-4	CMCT-6	CMCT-8	CMCT-10
Compressor	16-0322-00	16-0322-00	16-0323-00	16-0324-00
Start Relay	17-0163-00	17-0163-00	17-0163-00	17-0167-00
Start Capacitor	17-0164-00	17-0164-00	17-0165-00	17-0168-00
Run Capacitor			17-0166-00	19-2678-00
Condenser Coil	51-0709-02	51-0709-02	51-0709-03	18-0533-00
Fan Motor	19-0933-00	19-0933-00	19-0933-00	19-0304-00
Fan Blade	19-0101-00	19-0101-00	19-0101-00	19-0706-00
Drier/ Filter	18-1109-00	18-1109-00	18-1109-00	18-1109-00
Heat Exchanger	50-1106-01	50-1106-01	50-1106-03	50-1109-00
CRO Valve	18-0365-00	18-0365-00	18-0365-00	18-0315-00
Capillary Tube	14-2402-00	14-2402-00	14-2405-00	14-2403-00
Evaporator Coil	18-0079-06	18-0079-08	18-0079-10	18-0009-07
Heater, Defrost	19-1243-01	19-1243-03	19-1243-05	19-1243-06
Thermostat, Defrost Term	19-0833-00	19-0833-00	19-0833-00	19-0833-00
Heater, Front Glass	19-0231-01	19-0231-03	19-0231-05	19-0231-06
Heater, Baffle	19-0235-07	19-0235-09	19-0235-11	19-0235-12
Heater, End Breaker	19-0853-00	19-0853-00	19-0853-00	19-0853-00
Thermostat, control	19-0190-00	19-0190-00	19-0190-00	19-0190-00
Switch, Power	19-0103-00	19-0103-00	19-0103-00	19-0103-00
Time Clock	24-0513	24-0513	24-0513	19-0624-00
Service Cord	19-0620-00	19-0620-00	19-0620-00	
Switch, Light	19-0133-00	19-0133-00	19-0133-00	19-0133-00
Ballast, Lamp 30 Watt	19-0458-00	19-0458-00	19-0458-00	19-0458-00
Ballast, Lamp 20 Watt		19-0146-00		
Lamp, Fluorescent 30 Watt	19-0150-00	19-0150-00	19-0150-00	19-0150-00
Lamp, Fluorescent 20 Watt		19-0149-00		
Lamp, Fluorescent 34 Watt			19-0151-00	
Lampholder	19-0142-00	19-0142-00	19-0142-00	19-0142-00
Lampholder w/Starter Socket	19-0143-00	19-0143-00	19-0143-00	19-0143-00
Lamp Starter, 30-40 watt	19-0145-00	19-0145-00	19-0145-00	19-0145-00
Lamp Starter, 20 watt		19-0144-00		
Track, LH End	08-0161-01	08-0161-01	08-0161-01	08-0161-01
Track, RH End	08-0161-02	08-0161-02	08-0161-02	08-0161-02
Track, Center	08-0190-00	08-0190-00	08-0190-00	08-0190-00
Track, Lid Slide	10-0200-00	10-0200-01	10-0200-02	10-0200-03
Bumper, Front	08-0165-01	08-0165-03	08-0165-05	08-0165-06
Trim, Front Bumper	10-0936-01	10-0936-03	10-0936-05	10-0936-06
Rail, glass	08-0168-01	08-0168-03	08-0168-05	08-0168-06
Post, Vertical Trim LH	08-0518-01	08-0518-01	08-0518-01	08-0518-01
Post, Vertical Trim RH	08-0518-02	08-0518-02	08-0518-02	08-0518-02
Trim, side Arm	10-0935-00	10-0935-00	10-0935-00	10-0935-00
Breaker, End Panel LH	10-0094-01	10-0094-01	10-0094-01	10-0094-01
Breaker, End Panel RH	10-0094-02	10-0094-02	10-0094-02	10-0094-02
Handle, Lid	10-0218-01	10-0218-03	10-0218-05	10-0218-06
Front Grill	50-4192-04	50-4192-04	50-4192-04	50-4192-04
Glass, Front	20-0008-01	20-0008-03	20-0008-05	20-0010-00
Lid Assy, Glass	50-1756-07	50-1756-09	50-1756-11	50-1756-12
Glass, Lid	20-0047-01	20-0047-03	20-0047-05	20-0047-06
Counter Top	12-0522-01	12-0522-03	12-0522-05	12-0522-06

EXPORT CMCT PARTS LIST – R-404

Export Parts List - CMCT's			
Description	ECMCT-4	ECMCT-6	ECMCT-8
Compressor	16-0298-00	16-0298-00	16-0290-00
Start Relay	17-0167-00	17-0167-00	17-0167-00
Start Capacitor			
Run Capacitor	19-2678-00	19-2678-00	19-2678-00
Condenser Coil	51-0709-03	51-0709-03	51-0709-03
Fan Motor	19-0501-00	19-0501-00	19-0501-00
Fan Blade	19-0101-00	19-0101-00	19-0101-00
Drier/ Filter	18-1109-00	18-1109-00	18-1109-00
Heat Exchanger	50-1106-02	50-1106-02	50-1106-03
CRO Valve			18-0365-00
Capillary Tube	14-2402-00	14-2402-00	14-2405-00
Evaporator Coil	18-0079-06	18-0079-08	18-0079-10
Heater, Defrost	19-0891-01	19-0891-03	19-0891-05
Thermostat, Defrost Term	19-0833-00	19-0833-00	19-0833-00
Heater, Front Glass	19-0890-01	19-0890-03	19-0890-05
Heater, Baffle	19-0907-01	19-0907-03	19-0907-05
Heater, End Breaker	19-0893-00	19-0893-00	19-0893-00
Thermostat, control	19-0190-00	19-0190-00	19-0190-00
Switch, Power	19-0103-00	19-0103-00	19-0103-00
Time Clock	19-0864-00	19-0864-00	19-0864-00
Service Cord	19-0620-00	19-0620-00	19-0620-00
Switch, Light	19-0133-00	19-0133-00	19-0133-00
Ballast, Lamp 30 Watt	19-0911-00	19-0911-00	19-0911-00
Ballast, Lamp 20 Watt		19-0912-00	22-0200
Lamp, Fluorescent 30 Watt	19-0150-00	19-0150-00	19-0150-00
Lamp, Fluorescent 20 Watt		19-0149-00	
Lamp, Fluorescent 34 Watt			19-0151-00
Lampholder	19-0142-00	19-0142-00	19-0142-00
Lampholer w/Starter Socket	19-0143-00	19-0143-00	19-0143-00
Lamp Starter, 30-40 watt	19-0145-00	19-0145-00	19-0145-00
Lamp Starter, 20 watt		19-0144-00	
Track, LH End	08-0161-01	08-0161-01	08-0161-01
Track, RH End	08-0161-02	08-0161-02	08-0161-02
Track, Center	08-0190-00	08-0190-00	08-0190-00
Track, Lid Slide	10-0200-04	10-0200-05	10-0200-06
Bumper, Front	08-0165-01	08-0165-03	08-0165-05
Trim, Front Bumper	10-0936-01	10-0936-03	10-0936-05
Rail, glass	08-0168-01	08-0168-03	08-0168-05
Post, Vertical Trim LH	08-0518-01	08-0518-01	08-0518-01
Post, Vertical Trim RH	08-0518-02	08-0518-02	08-0518-02
Trim, side Arm	10-0935-00	10-0935-00	10-0935-00
Breaker, End Panel LH	10-0094-01	10-0094-01	10-0094-01
Breaker, End Panel RH	10-0094-02	10-0094-02	10-0094-02
Handle, Lid	10-0218-01	10-0218-03	10-0218-05
Front Grill	50-4192-04	50-4192-04	50-4192-04
Glass, Front	20-0008-01	20-0008-03	20-0008-05
Lid Assy, Glass	50-1756-07	50-1756-09	50-1756-11
Glass, Lid	20-0047-01	20-0047-03	20-0047-05
Counter Top	12-0522-01	12-0522-03	12-0522-05

Free Manuals Download Website

<http://myh66.com>

<http://usermanuals.us>

<http://www.somanuals.com>

<http://www.4manuals.cc>

<http://www.manual-lib.com>

<http://www.404manual.com>

<http://www.luxmanual.com>

<http://aubethermostatmanual.com>

Golf course search by state

<http://golfingnear.com>

Email search by domain

<http://emailbydomain.com>

Auto manuals search

<http://auto.somanuals.com>

TV manuals search

<http://tv.somanuals.com>